

BALL TRANSFERS



TABLE OF CONTENTS

BALL TRANSFERS

STANDARD CAPACITY

HIGH CAPACITY

BALL TRANSFERS STANDARD CAPACITY

4040 Free Ball



The 5/8" diameter main ball of this compact unit is supported by 3/32" balls in a hardened cup. This unit is engineered for ball-up mounting. Load rating, 40 lbs.

Part No.	Ball & Support Cup Material	Housing Material
4040-02	Carbon Steel	C.R.S. Zinc Plate

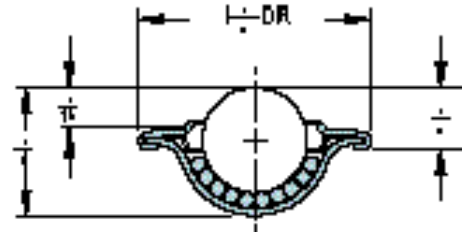

4180 Free Ball



This versatile unit consists of a 1" diameter main ball which rotates on 1/8" support balls in a hardened cup. This unit is engineered for ball-up mounting. Load rating, 125 lbs.

Part No.	Ball & Support Cup Material	Housing Material
4180-02	Carbon Steel	C.R.S. Zinc Plate
4180-32	Stainless Steel	C.R.S. Zinc Plate

Carbon steel flange with two-hole mounting is also available.
55270-92 Carbon Steel C.R.S. Cad Plate

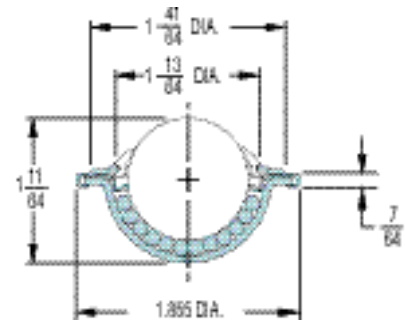

4233 Spring Loaded



Pre-loaded spring (65 lb. load) to allow 1/4" vertical ball deflection is built in this sealed, self-contained unit. A molded nylon seal on the 1" diameter main ball is standard and is positively retained. Engineered for ball-up applications only. Load rating, 125 lbs.

Part No.	Ball & Support Cup Material	Housing Material
4233-01	Carbon Steel	C.R.S. Zinc Plate
4233-32	Stainless Steel	C.R.S. Zinc Plate

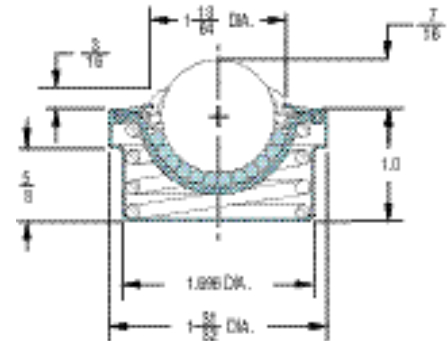

4232 Spring Loaded



A pre-loaded spring (65 lb. load) to allow 1/4" vertical ball deflection is built in this sealed, self-contained unit. A molded nylon seal on the 1" diameter main ball is standard and is positively retained. Engineered for ball-up applications only. Load rating, 125 lbs. Equivalent to 4233, with a flange

Part No.	Ball & Support Cup Material	Housing Material
4232-01	Carbon Steel	C.R.S. Zinc Plate
4232-32	Stainless Steel	C.R.S. Zinc Plate

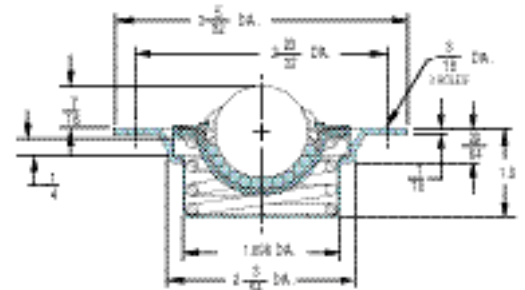

Ball Transfer

Absolute load sharing in applications where the load rests on many ball transfers is seldom, if ever, achieved. Pallet flatness, ball transfer installed heights and system deflections will cause uneven load distribution. As a general rule of thumb, a safety factor of 3 may be used, but the user should be attentive to load sharing consideration in his application. Note that spring loaded units tend to minimize load sharing problems.

Mounting and spacing recommendations are available on request.



4240 Stud Mounted

This Ball Transfer consists of a 1" diameter carbon steel main ball, fitted with a molded nylon wiper seal, rotating on 1/8" support balls. Load rating, 75 lbs. Recommended for ball-up mounting only.

Part No.	Ball & Support Cup Material	Housing Material
4240-03	Carbon Steel	C.R.S. Black Oxide Finish
*4242-03	Carbon Steel	C.R.S. Black Oxide Finish

*Equivalent to 4240, without threaded stud.

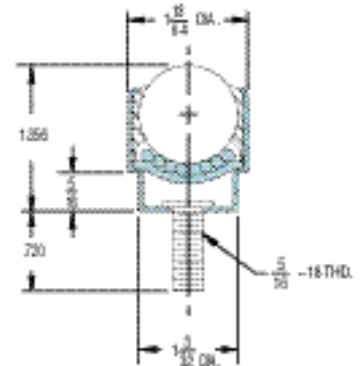

4550 Stud Mounted

This all steel Ball Transfer has a 1" diameter carbon steel main ball rotating on 1/8" support balls. Load rating, 125 lbs.

Part No.	Ball & Support Cup Material	Housing Material
4550-03	Carbon Steel	C.R.S. Black Oxide Finish

Engineered for ball-up or ball-down mounting.

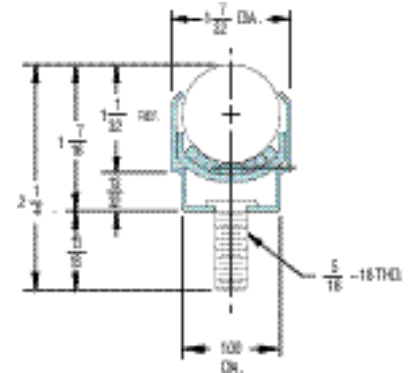

4230 Flange Mounted

This all steel ball transfer has a two-hole flanged base for easy mounting and is designed for ball-up applications only. The 1" diameter main ball rotates on 1/8" support balls in a hardened steel cup. Load rating, 125 lbs.

Part No.	Ball & Support Cup Material	Housing Material
4230-01	Carbon Steel	C.R.S. Zinc Plate
4230-38	Stainless Steel	Stainless Steel

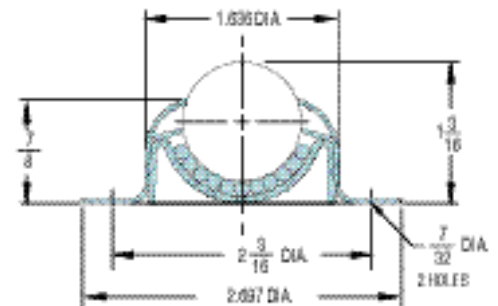

4260 Heavy Duty, Flanged Mounted

This heavy duty ball transfer has a 1-1/2" diameter main ball and four-hole flange base. The main ball rotates on 3/16" hardened and ground support balls in a precision formed and hardened ball cup. Load rating, 250 lbs.

Part No.	Ball & Support Cup Material	Housing Material
4260-01	Carbon Steel	C.R.S. Zinc Plate
4260-38	Stainless Steel	Stainless Steel

Engineered for ball-up mounting only.

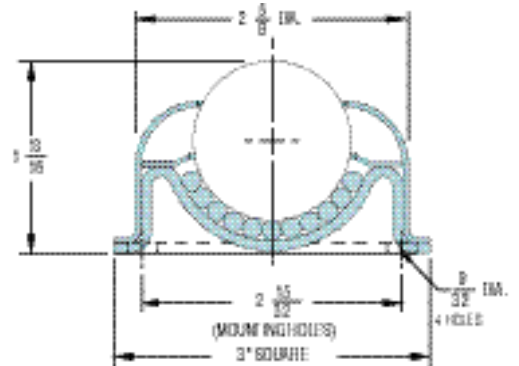

BALL TRANSFERS HIGH CAPACITY

General Bearing Ball Transfers are manufactured to the high standards required by the Engineering and Scientific Industries. They are available in a wide range of sizes, application styles, and load capacities. They will function efficiently whether mounted "Ball Up", "Ball Down", or in any angle of inclination as long as the applied load passes through the center line of the unit. For heavy loads where uneven load or track conditions exist, or where shock loading may occur, they can be supplied with spring mounting. This type of mounting is also available where full retraction of the ball is required after final positioning of load. Allow for any known unevenness of load and/or track when considering capacity and number of units to be used. Standard units come with a carbon steel housing and first quality chrome steel balls. Optional units can come with a stainless steel housing, main ball, and/or support balls.

However, if stainless steel balls are required, the load capacity is reduced by 33%. Felt

seals are standard except for the 1/2" ball diameter units which have no seal. The standard finish is zinc plating with gold passivation or black oxide. Lubrication is not required. The maximum recommended surface speed is 60 feet per minute and the operating coefficient of friction is 0.5%. The size tolerance is 1/4" unless otherwise specified. The maximum operating temperature at the listed capacities is 250°F. These ball transfers can operate at up to 480°F at reduced capacities as described below:

Temperature (°F)	260°	300°	350°	390°	440°	480°
Load % Decrease	5%	10%	15%	25%	35%	40%

Applications include: Sheet Steel Handling, Jig and Tool Handling, Air Cargo, Conveyor Transfer Points, Atomic Research, Tube Handling and Inspection, Ball Tables and Moveable Acoustic Walls.



4100 Series									
Part Number	Capacity (lbs.)	Ball Diameter	A	B	C	D	E	F	Weight (lbs.)
41051	75	1/2	5/32	7/8	25/32	7/8	5/8	3/32	0.08
41061	350	1	9/32	1 3/4	1 5/8	NA	NA	NA	0.84
41062	700	1	1/4	2	1 3/4	NA	NA	NA	1.16
41063	2240	1 1/2	1/2	2 3/8	2 3/8	NA	NA	NA	2.38
41064	4480	2	5/8	4 1/2	3 7/8	NA	NA	NA	11.93



4110 Series — Threaded Stud Units									
Part Number	Capacity (lbs.)	Ball Diameter	A	B	C	D	E	Weight (lbs.)	
41151	75	1/2	5/32	7/8	7/8	1	5/16-24	0.09	
41161	350	1	9/32	1 3/4	2	1	1/2-20	0.95	
41162	700	1	1/4	2	2 1/8	1	1/2-20	1.38	
41163	2240	1 1/2	1/2	2 3/8	2 7/8	1 1/2	3/4-16	2.75	
41164	4480	2	5/8	4 1/2	4 7/16	2	1-12	11.81	

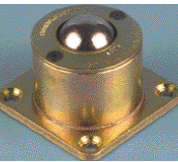

4120 Series — Flange Mounted Units										
Part Number	Capacity (lbs.)	Ball Diameter	A	B	C	D	E	F	G	Weight (lbs.)
41251*	75	1/2	5/32	1	7/8	5/64	1 7/8 x 1 1/4	1 3/8*	5/32	0.17
41261	350	1	9/32	1 3/4	1 5/8	3/16	2 1/4 Sq.	1 3/4 Sq.	7/32	0.98
41262	700	1	1/4	2	1 3/4	1/4	3 Sq.	2 9/32 Sq.	9/32	1.69
41263	2240	1 1/2	1/2	2 3/8	2 3/8	1/2	3 Sq.	2 9/32 Sq.	9/32	2.75
41264	4480	2	5/8	4 1/2	3 7/8	1/2	5 Sq.	4 Sq.	7/16	13.38

*Two bolt flange this size only. All others have square flange.

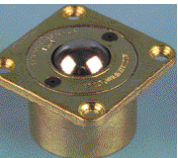

4130 Series — Flange Socket Mounted										
Part Number	Capacity (lbs.)	Ball Diameter	A	B	C	D	E	F	G	Weight (lbs.)
41351*	75	1/2	5/16	1	5/8	5/64	1 7/8 x 1 1/4	1 3/8*	5/32	0.17
41361	350	1	15/32	1 3/4	1 5/32	3/16	2 1/4 Sq.	1 3/4 Sq.	7/32	0.98
41362	700	1	1/2	2	1 1/4	1/4	3 Sq.	2 9/32 Sq.	9/32	1.69
41363	2240	1 1/2	1	2 3/8	1 3/8	1/2	3 Sq.	2 9/32 Sq.	9/32	2.75
41364	4480	2	1 7/16	4 1/4	2 7/16	1/2	5 Sq.	4 Sq.	7/16	12.75

*Two bolt flange this size only. All others have square flange.



4140 Series — Spring Loaded Ball Transfer Units									
Part Number	Load to max. deflection (lbs.)	Maximum recommended deflection	A	B	C	D	E		
41451-15	70	.105	1.535	7/8	1 7/8	5/8	13/16		
41451-30	77	.105	1.517						
41451-50	83	.119	1.535						
41461-15	225	.196	2.44	1 3/4	3 1/32	7/8	1 1/4		
41461-50	240	.196	2.42						
41461-100	265	.196	2.40						
41461-150	275	.224	2.43						
41462-200	460	.342	3.18	2	3 7/8	7/8	1 1/2		
41462-300	540	.342	3.14						
41462-400	600	.373	3.17						
41462-500	680	.404	3.19						
41463-1250	1825	.218	5.30	2 3/8	6 11/32	1 13/32	211/32		
41463-1650	2203	.218	6.15						
41464-1680	3080	.250	5.47	4	6 5/16	2	4		

All dimensions in inches.

