

# Series M and H Bearings

## Introduction

Series M designates a medium duty four-point contact ball bearing. The non-gearred races are flanged. Substantial clearance is provided and raceway geometry is designed to tolerate mounting structures less flat and rigid than otherwise required for heavy duty bearings.

Series H7 is a heavy duty version of the Series M bearing. Rectangular sections, decreased clearance, modified geometry and additional mounting holes provide the Series H7 with more static capacity than the M Series.

Series H12 is a larger version of the Series H7. The ball diameter and race cross sections are increased over the Series H7 providing substantially more static capacity.

## Construction

These bearings are produced from special alloy steel. The ball paths are induction hardened to 58-62 Rc. Balls are made from A.I.S.I. 52100 steel.

## Advantages

Steel is generally stocked for the M and H7 designs. Prompt deliveries of standard designs are common. Design changes, utilizing the steel forgings, can be easily accommodated with little impact to lead time. The Series H12 is ideal for applications requiring more static capacity than the series H7.

## Applications

Ideal applications for Series M and H bearings include aerial lifts, digger derricks, chute swivels, lift truck rotators, stretch wrapping equipment, industrial turntables, small cranes and gun mounts.

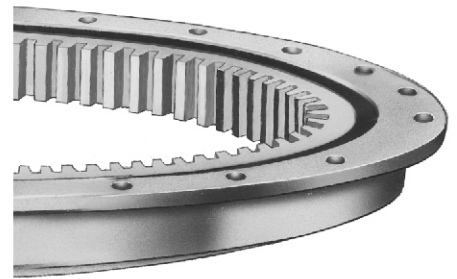

Figure 3-1A Typical M Series

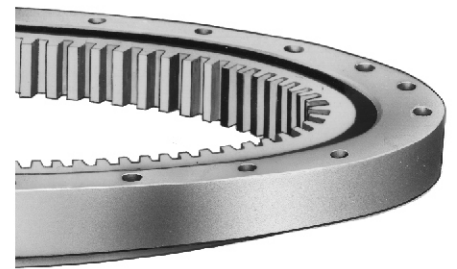

Figure 3-1B Typical H Series





# Series M and H Bearings

**No. 1 (M7, EXTERNAL GEAR)**

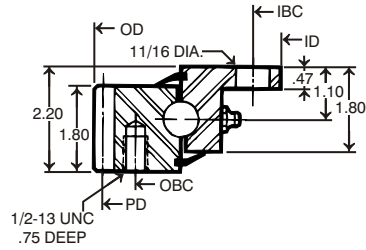

**No. 2 (M7, INTERNAL GEAR)**

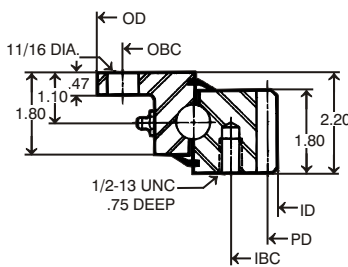

**No. 3 (M7, GEARLESS)**

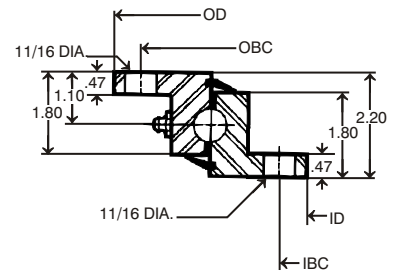

**No. 4 (H7, EXTERNAL GEAR)**

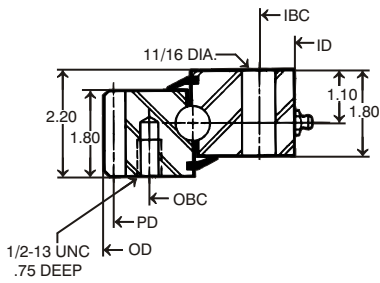

**No. 5 (H7, INTERNAL GEAR)**

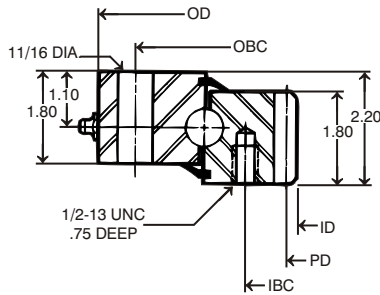

**No. 6 (H7, GEARLESS)**

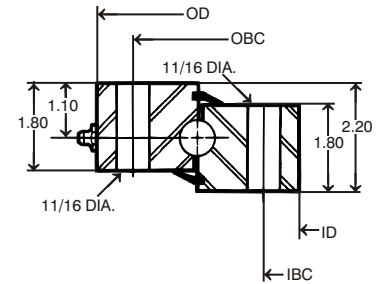

**No. 7 (H12, EXTERNAL GEAR)**

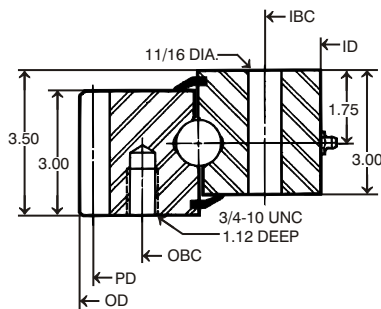

**No. 8 (H12, INTERNAL GEAR)**

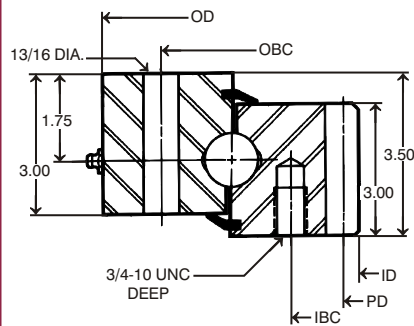

**No. 9 (H12, GEARLESS)**

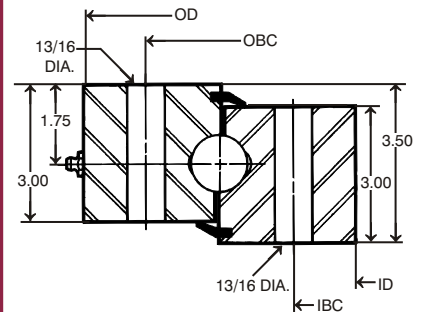



**AVON**  
**BEARINGS**

**ENGINEERING GUIDE  
and  
CATALOG**



**AVON BEARINGS CORPORATION**

1500 Nagle Road • Avon, Ohio 44011

Telephone: 440-871-2500 • Fax: 440-871-2503 • Toll Free: 800-286-6274

www.avonbearings.com • E-Mail: [info@avonbearings.com](mailto:info@avonbearings.com)