

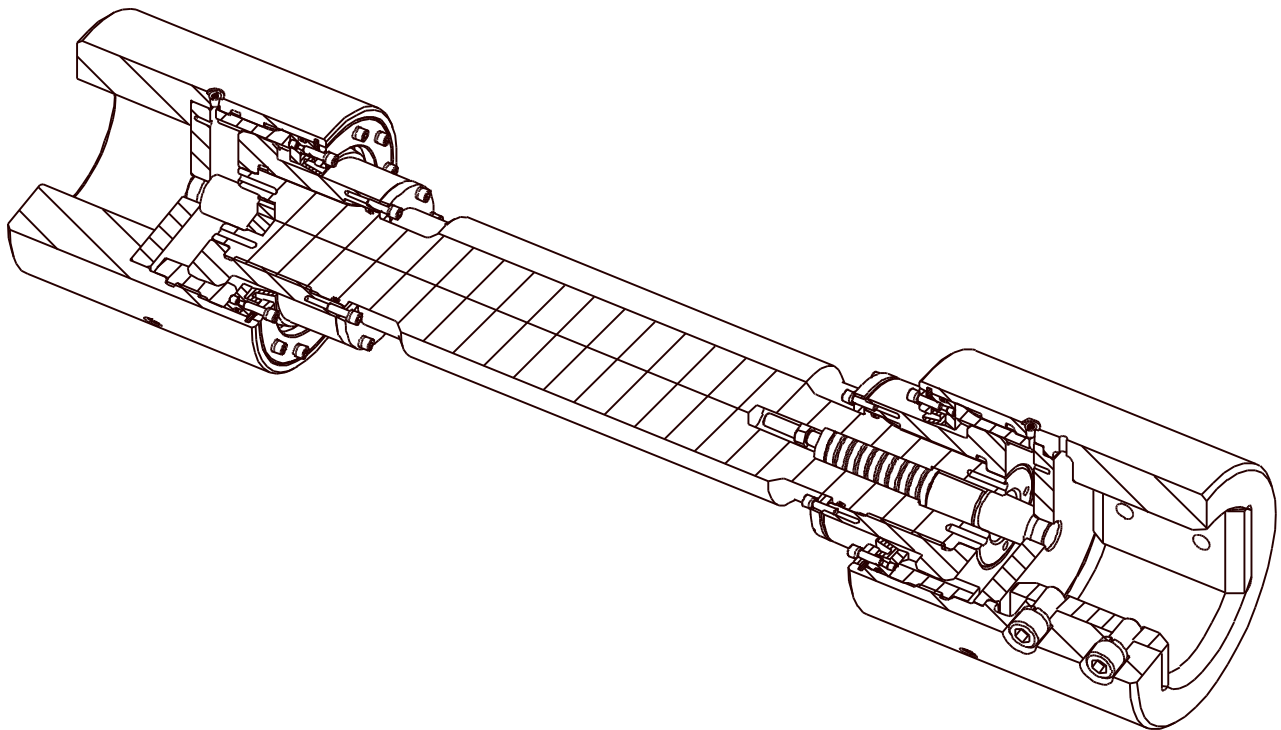

Amerigear[®]

SM Spindle

**High Capacity Industrial Mill Spindles
Installation and Maintenance Manual**



Ameridrives International
Coupling Products



Spindle Installation and Maintenance Manual

TABLE OF CONTENTS

SECTION	TITLE	PAGE
1	Introduction.....:	4
2	General Information.....:	4
3	Description of Terminology.....:	4
4	Pre-Installation Instructions.....:	11
5	Installation.....:	11
6	Spindle Lubrication.....:	14
7	Assembly Check.....:	15
8	General Maintenance.....:	16
9	Disassembly Procedure.....:	16
10	Ordering Information.....:	19

WARNING

ACCIDENTS INVOLVING ROTATING EQUIPMENT MAY RESULT IN LOSS OF LIFE, SERIOUS BODILY INJURY OR PROPERTY DAMAGE. THE PURCHASER OF THIS EQUIPMENT MUST ASSURE THAT THE EQUIPMENT IS PROPERLY ASSEMBLED, INSTALLED, SHIELDED, OPERATED AND MAINTAINED. THIS EQUIPMENT MUST NOT BE OPERATED AT CONDITIONS THAT EXCEED MANUFACTURER'S SPECIFICATIONS.

PURCHASER MUST FOLLOW ALL FEDERAL, STATE AND LOCAL LAWS AND REGULATIONS COVERING THE SAFE OPERATION AND MAINTENANCE OF THE EQUIPMENT, INCLUDING, WITHOUT LIMITATION, THE USDOL-OSHA "LOCKOUT/TAGOUT" PROCEDURE SET FORTH IN 29 CFR 1910.147.

IT IS THE PURCHASERS RESPONSIBILITY TO IMPLEMENT AND FOLLOW ITS OWN SAFETY, MAINTENANCE, AND EMPLOYEE TRAINING PROGRAM REGARDING THE SAFE AND PROPER OPERATION AND MAINTENANCE OF THE EQUIPMENT.

NOTE: THIS DOCUMENT SUPERSEDES IM4-005

1 INTRODUCTION

This Installation Manual is intended to be used as a guide for the installation and maintenance of Amerigear Flexible Spindles. For specific operating capacities and coupling data, refer to the Ameridrives Sales Drawing.

2 GENERAL INFORMATION

Ameridrives Amerigear SM series spindles are designed for use in rolling mill applications. Amerigear spindles transmit torque while operating at specific misalignments between driving and driven equipment. The gear teeth are designed to accommodate both full load and no-load misalignments. The curvature on the flanks and the tips of external gear teeth allow the gear mesh to operate in a misaligned condition. The amount of curvature is varied in order to optimize performance under specific operating conditions. Refer to the applicable Ameridrives Sales Drawing for specific full load and no load capability.

This manual should be used as a guide for installation, lubrication, maintenance, and trouble shooting of Amerigear spindles. Spindle designs vary widely due to the specific requirements of each application. This manual covers the most common designs.

3 DESCRIPTION OF TERMINOLOGY

This section is intended to assist anyone not familiar with the terms used to describe the components of an Amerigear Flexible Spindle. Refer to Figures 3-1 through 3-6 for the coupling type specified on the Ameridrives Sales Drawing. These figures identify components and terms referred to in this manual. The figures shown depict typical spindle arrangements, refer to the applicable Ameridrives Sales Drawing for the specific design features and parts list.

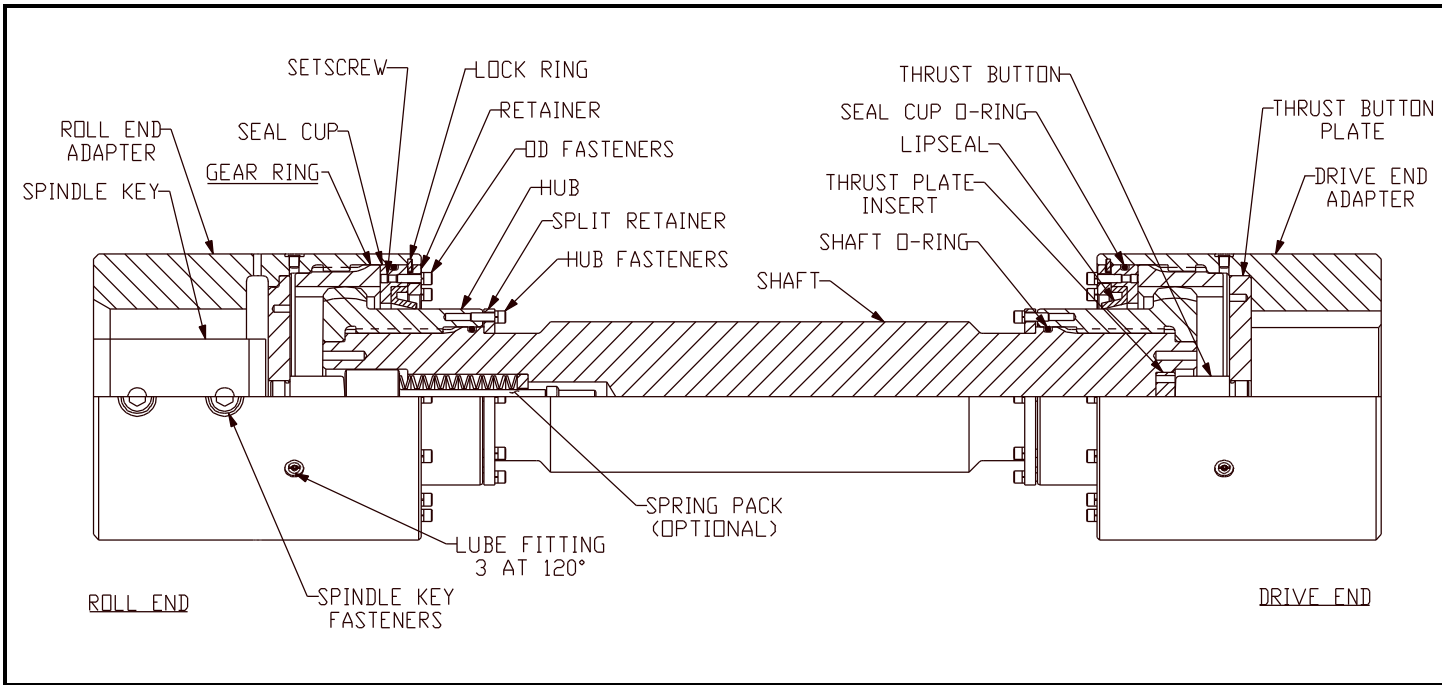

**Figure 3-1
Typical Spindle Design**

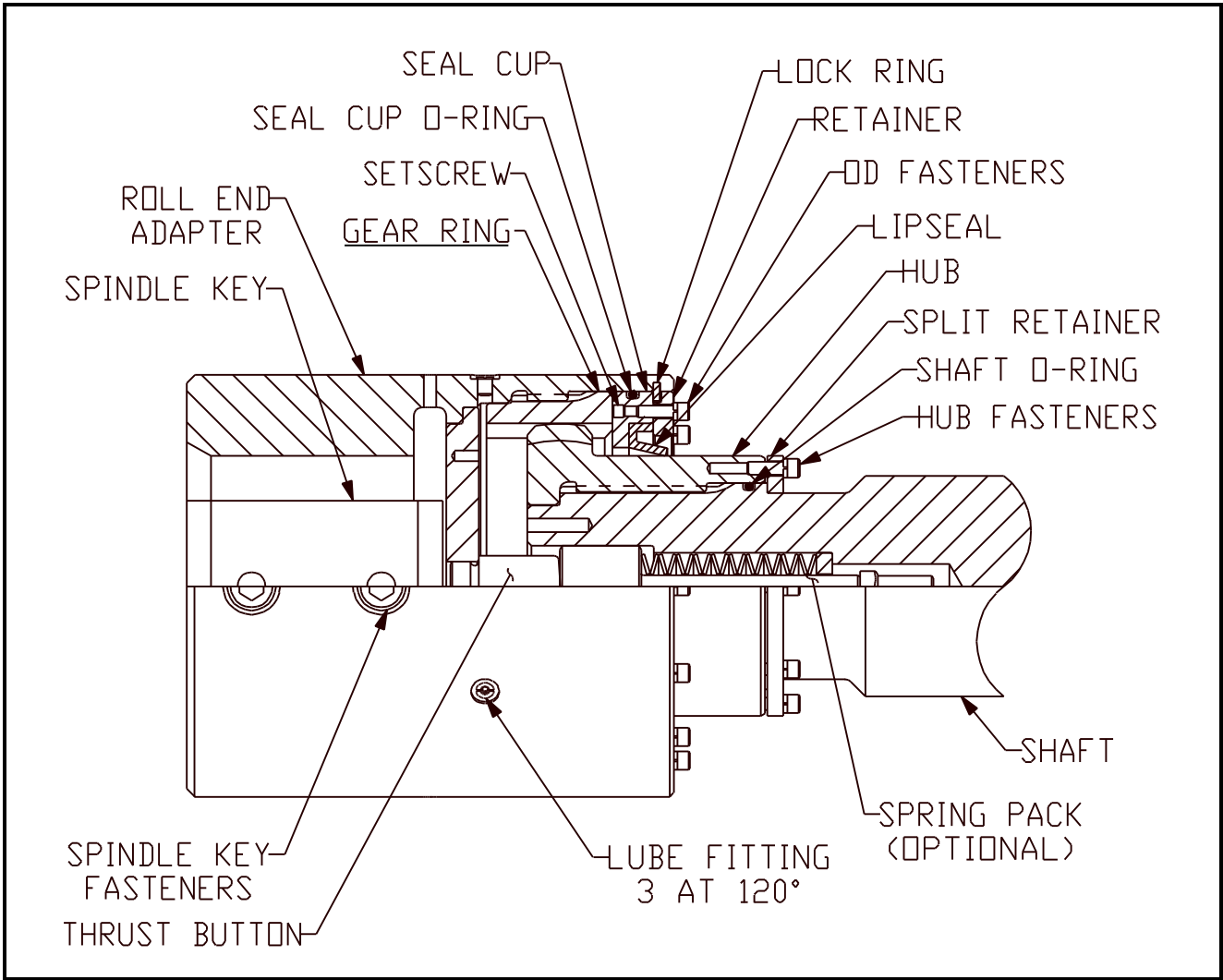

**Figure 3-2
Spindle With Gear Ring**

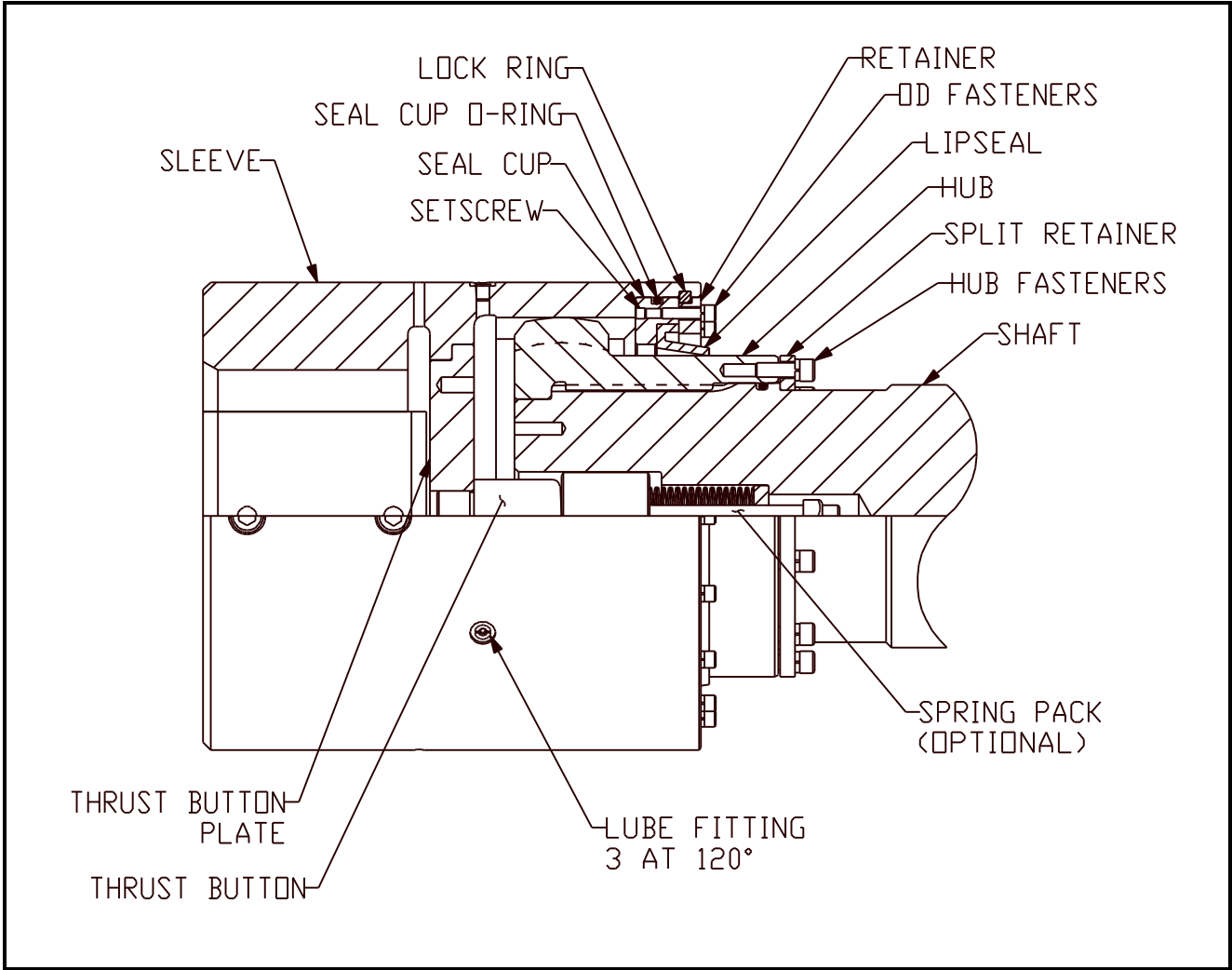

**Figure 3-3
Spindle Without Gear Ring**

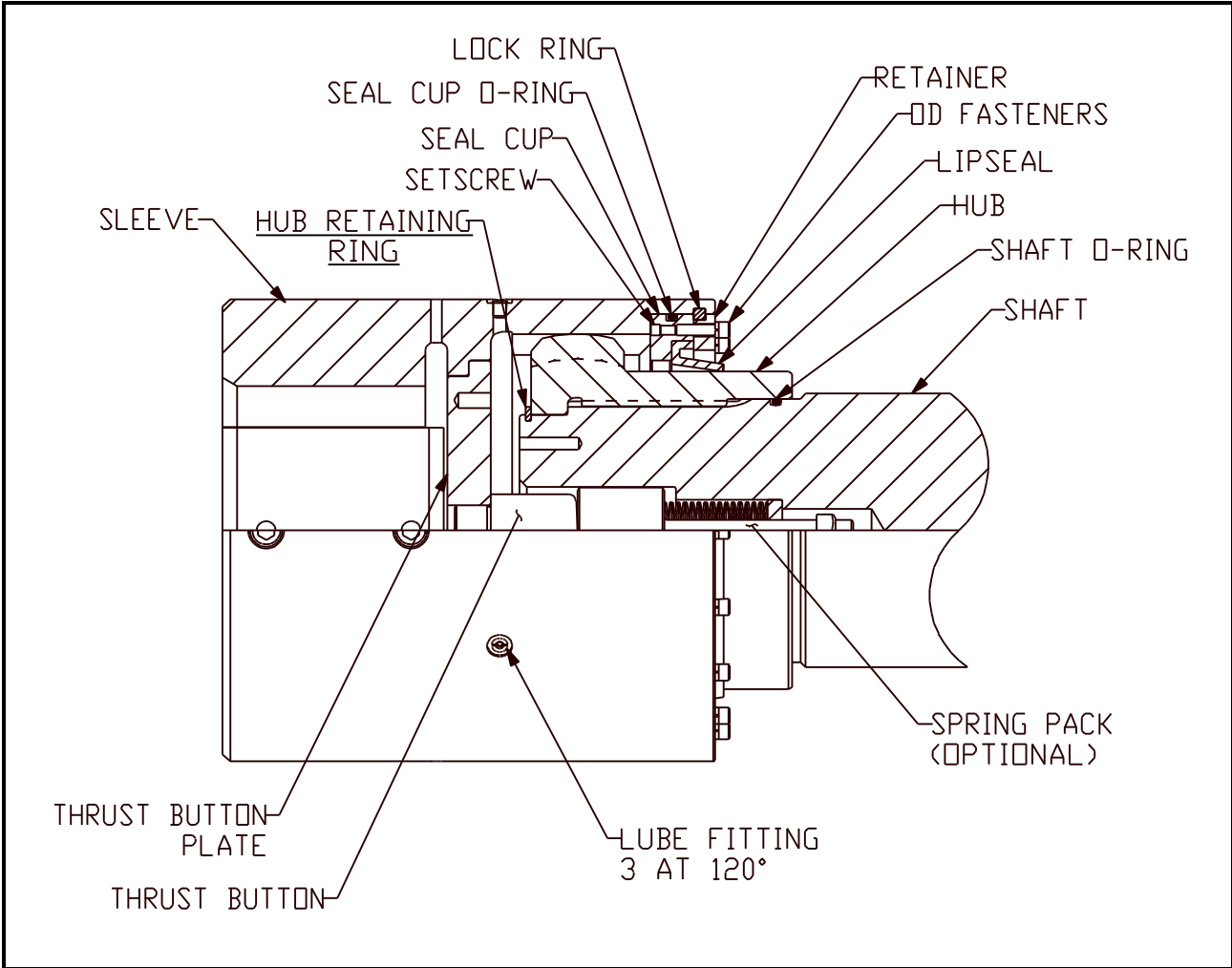

**Figure 3-4
Spindle With Retaining Ring For Hub Retention**

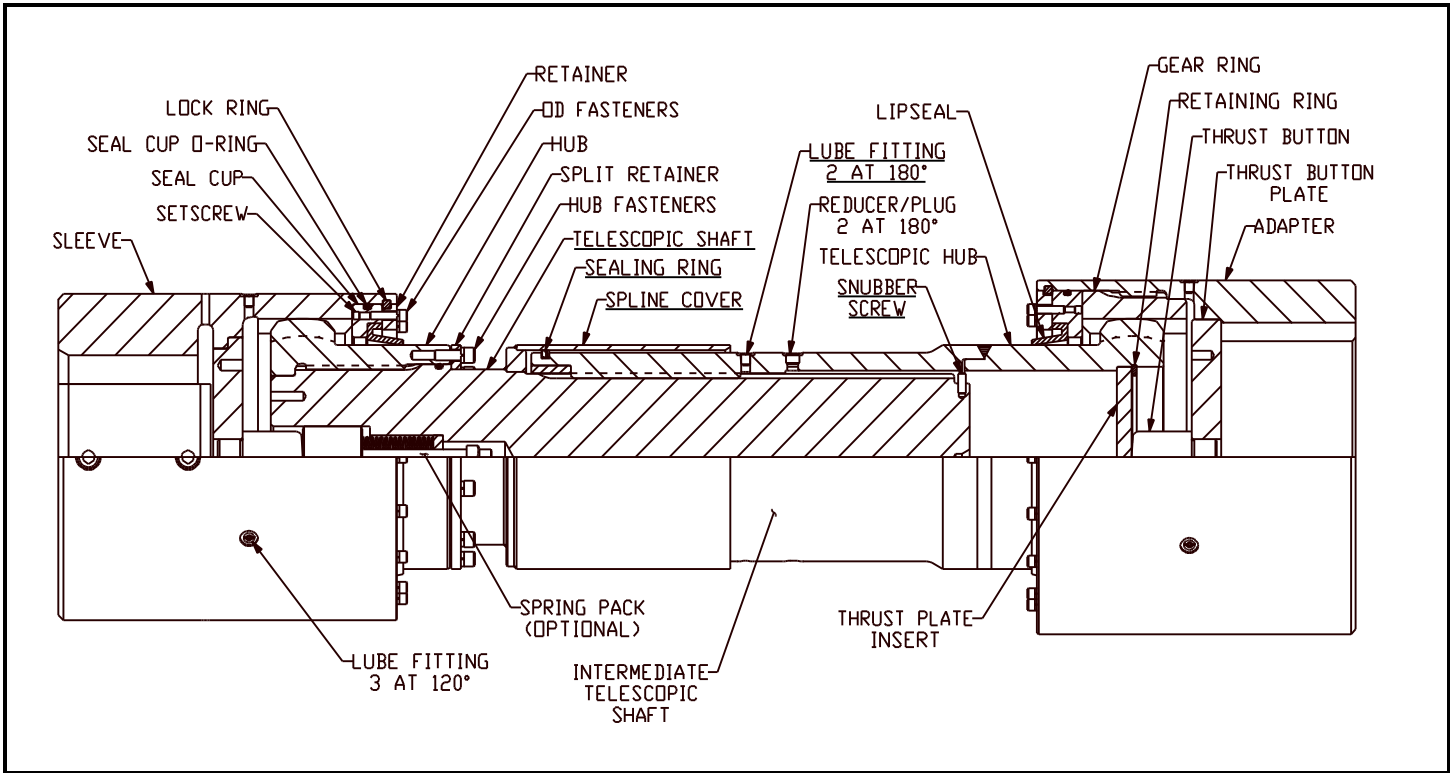

Figure 3-5
Spindle With Intermediate Telescopic Shaft And Snubbing Screws

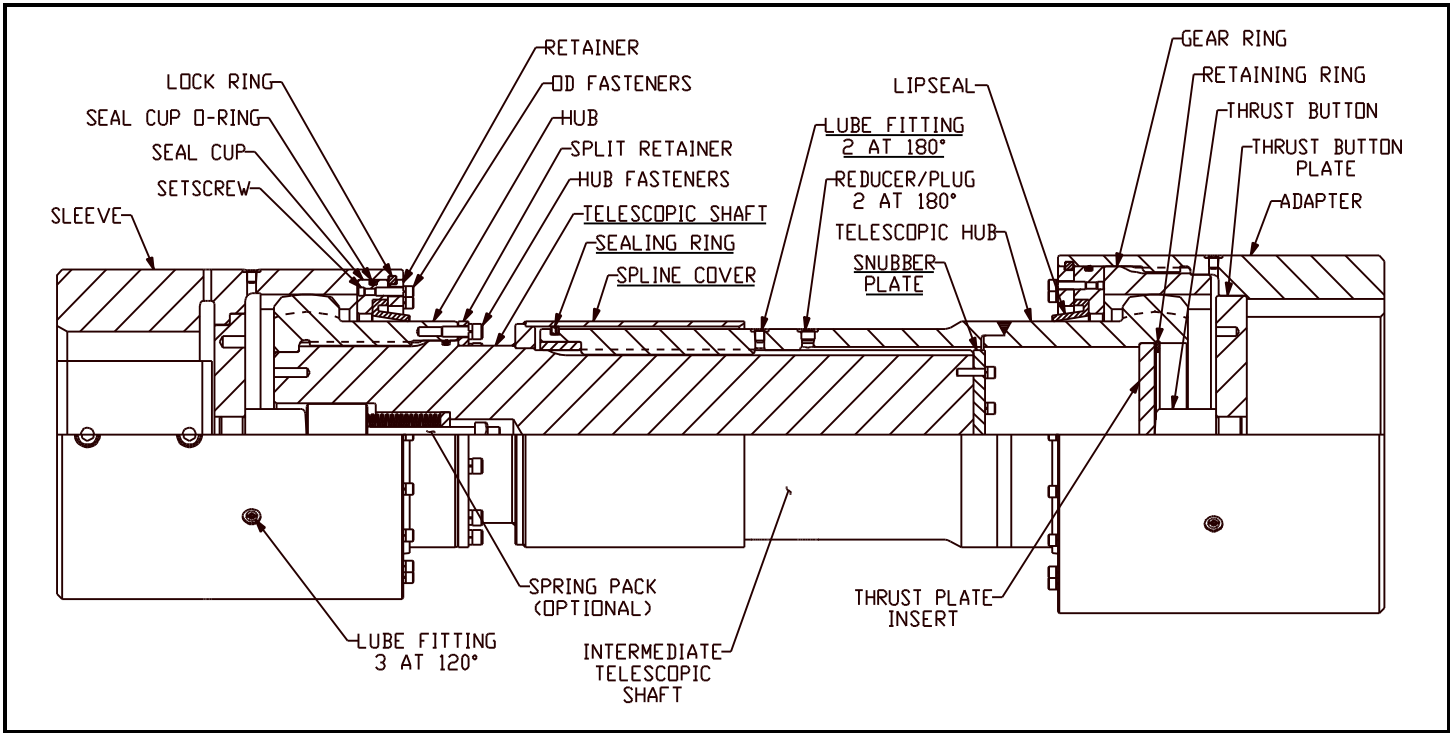

Figure 3-6
Spindle With Intermediate Telescopic Shaft And Snubber Plate

4 PRE-INSTALLATION INSTRUCTIONS

Refer to the referenced Ameridrives Sales Drawing to confirm specific set-up dimensions. Spindles are shipped completely assembled with critical exposed surfaces protected and coated with a preservative. At installation this coating should be removed with solvent.

If the assembly is to be stored for an extended period, do not remove the preservative. Be sure that the storage area is dry. If stored outdoors, the spindle assembly must be crated and protected from moisture at all times. Place supports under the unit to keep it off the ground.

When spindles are received:

- 4.1 Check for possible shipping damage or shortages.
- 4.2 Gear teeth are **NOT** fully lubricated at the factory and must be lubricated prior to operation.
- 4.3 Hub and shaft splines are factory lubricated, but must be cleaned and relubricated if disassembled. Intermediate shafts with telescopic center sections are lightly greased by hand at the factory and must be lubricated before start-up.
- 4.4 Partial disassembly is required for installation. See **INSTALLATION** Section 5.

CAUTION: IF THE SPINDLE HAS A TELESCOPIC INTERMEDIATE SHAFT (FIGURES 3-5 AND 3-6), DO NOT PLACE A SLING OR CHAIN AROUND THE SPLINE COVER WHEN LIFTING OR TRANSPORTING. ALWAYS HANDLE AND TRANSPORT IN A HORIZONTAL POSITION EXCEPT WHEN HANDLING A UNIT DESIGNED FOR VERTICAL APPLICATIONS.

5 INSTALLATION

Ameridrives Amerigear Flexible Spindle Assemblies are designed to give maximum performance for the required operating conditions specified on the Ameridrives Sales Drawing. Refer to the Sales Drawing for the actual distance between shaft ends requirement. The initial angular and parallel offset alignment of the equipment to be coupled should be set and secured so that the specified operating angle and parallel offset specified on the Sales Drawing are not exceeded. This will aid in assuring optimum life and performance of the spindle assembly.

The following is the recommended procedure for installation of a spindle assembly after alignment of the equipment is completed. This procedure is for an ideal situation where there are no obstructions to hinder installation.

- 5.1 Partial disassembly is usually required, take note of the matchmarks when specified on the Sales Drawing and end to end alignment requirements. Occasionally, because of size or customer's preference, the adapters/sleeves are not assembled. Check the assembly and Ameridrives Sales Drawing for matchmarks or other markings pertinent to the assembly. Refer to the Ameridrives Sales Drawing prior to and during installation for parts identification and specific set-up dimensions.

CAUTION: AMERIDRIVES MANUFACTURED THE COUPLING INTERFACE BASED ON THE SHAFT DATA SUPPLIED BY THE PURCHASER. AMERIDRIVES IS NOT RESPONSIBLE FOR INACCURATE OR INCOMPLETE INFORMATION SUPPLIED BY THE PURCHASER.

CAUTION: IT IS THE PURCHASERS RESPONSIBILITY TO ASSURE THAT THE INTERFACE CONNECTIONS (FLANGES, BOLTS, KEYS, HYDRAULIC FITS, ETC.) BETWEEN THE COUPLING AND THE CONNECTED EQUIPMENT ARE CAPABLE OF HANDLING ANTICIPATED LOADS.

5.2 Drive End:

- 5.2.1 Check bore, shaft diameter, and key(s) for proper fit. Verify that the engagement length between bore and shaft is correct.
- 5.2.2 Remove any nicks or dents with a fine grit stone.
- 5.2.3 Thoroughly clean and lubricate the drive end equipment shaft.
- 5.2.4 Drive end adapter/sleeve may require disassembly prior to mounting. See **DISASSEMBLY PROCEDURE** Section 9.
- 5.2.5 Drive end adapter/sleeve may be prepared for mounting by heating in oil or oven from 300°F to 350°F maximum. Higher temperatures should only be used if specified on the Sales Drawing.

CAUTION: DO NOT APPLY OPEN FLAME.

- 5.2.6 Apply lubricant sealing compound to key(s) and keyway(s) then assemble. Keys are typically installed flush with the shaft end.
- 5.2.7 Align the drive end adapter/sleeve and shaft keyway(s) and position the adapter/sleeve as shown on the reference Ameridrives Sales Drawing.

IMPORTANT: Prepare stops to prevent over engagement of adapter/sleeve at assembly.

- 5.2.8 Seat the thrust button plate and preassembled thrust button to full depth of counterbore. The thrust button plate may be pressed into position while the adapter/sleeve is still hot. Should it be necessary to shrink the plate, dry ice or liquid nitrogen are a suitable medium for chilling. Go to Section 5.2.11 if no gear rings are furnished. See the Ameridrives Sales Drawing and Figures 3-1 through 3-6 for the applicable design.
- 5.2.9 Check the cleanliness of the drive end adapter and gear ring spline teeth. Hand apply a thin amount of operating lubricant to each spline tooth of the gear ring and adapter.
- 5.2.10 Assemble gear ring.
- 5.2.11 Check the cleanliness of the drive end sleeve/gear ring internal and the hub external gear teeth. Hand pack a generous amount of operating lubricant to each gear tooth of the mating parts.
- 5.2.12 Support shaft assembly and engage the drive end adapter/sleeve and hub gear teeth.

CAUTION: IF THE SPINDLE HAS A TELESCOPIC INTERMEDIATE SHAFT (FIGURES 3-5 AND 3-6), DO NOT PLACE A SLING

OR CHAIN AROUND THE SPLINE COVER WHEN LIFTING OR TRANSPORTING. ALWAYS HANDLE AND TRANSPORT IN A HORIZONTAL POSITION EXCEPT WHEN HANDLING A UNIT DESIGNED FOR VERTICAL APPLICATIONS.

- 5.2.13 Seat seal cup, lipseal, and lock ring in the adapter/sleeve cavity. Install setscrews in seal cup and tighten until seal cup is pressed against the lock ring, see Figure 5-1.

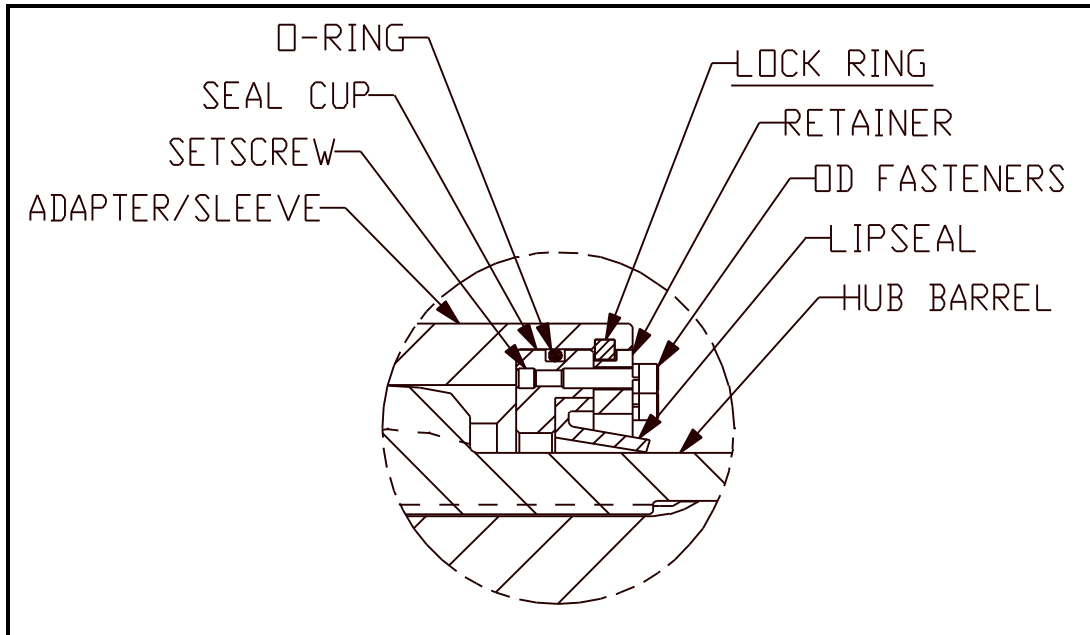

**Figure 5-1
Lock Ring**

- 5.2.14 Assemble retainer and OD fasteners and tighten to torque specified on the Ameridrives Sales Drawing.

5.3 Roll End:

- 5.3.1 If the roll end adapter/sleeve has a clearance fit disassembly is not required unless removal facilitates assembly due to obstructions, etc. If disassembly is required, see **DISASSEMBLY PROCEDURE** Section 9.
- 5.3.2 Thoroughly clean and inspect the roll end bore and flats for nicks and burrs. Deburr with fine grit stone or file.
- 5.3.3 Check bore, shaft diameter, and across flats for proper fit.
- 5.3.4 Assure that the support devices for the roll end adapter/sleeve are functioning properly. If locking or holding devices are required on the roll end, make sure they are functioning properly.

6 SPINDLE LUBRICATION

As previously stated, hub spline, intermediate shaft spline (unless telescopic), and shaft o-ring seals are factory lubricated. If for any reason these components are disassembled, they are to be thoroughly cleaned and lubricated by hand. The use of operating lubricant for this purpose is recommended. Storage over an extended period of time or adverse conditions are reasons for disassembly, cleaning and relubricating.

A high quality lithium based or synthetic EP lubricant in compliance with AGMA 9001 for high torque operating conditions should be used. The following greases comply with AGMA 9001 for high torque operating conditions and have been used successfully with Ameridrives Spindles:

Mobilux EP-111 by Mobil Oil Co.
Anderol 786 by Huls America,

For assistance in selecting lubricants from alternate suppliers please contact Ameridrives International.

CAUTION: TYPICALLY THE SPLINES AND SLEEVE/GEAR RINGS ARE LIGHTLY LUBED AT THE FACTORY WITH MOBILUX EP-111. THIS IS A LITHIUM BASED GREASE. OTHER TYPES OF GREASES MAY NOT BE COMPATIBLE. ALWAYS CONTACT THE LUBRICANT MANUFACTURER TO ASSURE COMPATIBILITY BEFORE USING DIFFERENT LUBRICANTS TO PREVENT PREMATURE FAILURE.

Gear teeth and telescopic splines are **NOT** fully lubricated at the factory. All gear teeth should be cleaned and hand packed with spindle operating lubricant as described in Section 5.2.11. Unless otherwise specified, Ameridrives spindles are provided with three (3) equally spaced lube fittings in the roll end and drive end adapters/sleeves. To assure complete lubrication of each gear mesh, the following procedure should be followed. **FOR TYPICAL MILL APPLICATIONS, LUBRICANT SHOULD BE ADDED TO EACH GEAR MESH ONCE A WEEK**

6.1 Lubricating Spindle Gear Teeth

- 6.1.1 Lube with work rolls installed, if possible. Provide a vent at about 12 o'clock position by inserting a small venting rod (**FREE OF BURRS**) between the hub barrel and the lip seal, see Figure 6-1.

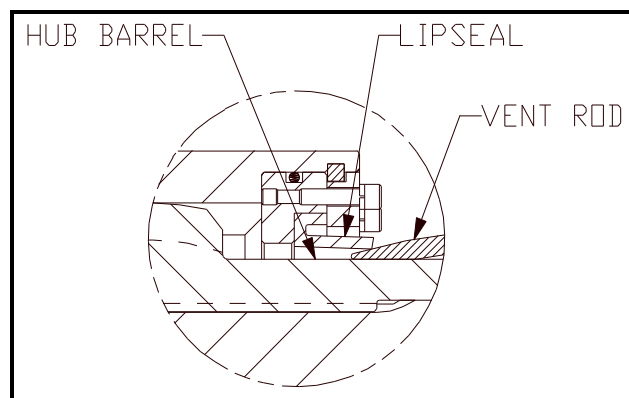

Figure 6-1
Lipseal

- 6.1.2 Locate one lube fitting below the horizontal centerline of the spindle. Pump the recommended amount of lubricant into the gear mesh cavity or until lube is noted at the vent rod or at any other portion of the lipseal inner diameter.

CAUTION: LUBRICATE BOTH GEAR MESHES.

6.1.3 Be sure all lube fittings are secured and remove vent rod.

6.2 Lubricating Telescopic Splines (Figures 3-5 and 3-6 only)

CAUTION: TELESCOPIC OR LENGTH COMPENSATING SPLINES ARE ONLY HAND WIPED WITH GREASE AT THE FACTORY AND MUST BE LUBRICATED PRIOR TO START-UP.

6.2.1 Lube the telescopic spline in a collapsed position. This will prevent the entire available lube cavity from being filled which could restrict length compensating travel.

6.2.2 Pump grease into one (1) of the two (2) lube fittings until it emerges past the sealing ring under the spline cover. See Figures 3-5 and 3-6 for the location of the telescopic spline lube fittings and sealing ring.

7 ASSEMBLY CHECK

7.1 Prior To Initial Operation

7.1.1 Verify that the application requirements comply with the operating conditions specified on the applicable sales drawing.

7.1.2 Check that all fasteners are properly torqued.

7.1.3 Verify that all lube fittings are secure.

7.1.4 Roll end and drive end gear mesh should be properly lubricated.

7.1.5 **BE SURE VENTING ROD HAS BEEN REMOVED** from between the lip seal and hub barrel at both ends.

7.1.6 Drive end keyway(s) must be oil tight.

7.2 During Operation

7.2.1 Observe general alignment and operating conditions. Excessive vibration, noise and/or overheating generally indicates a problem. Shut down is recommended, see Section 8.

7.2.2 Inspect for evidence of lube leakage.

7.3 After Operation

7.3.1 The entire spindle should be checked after **ONE WEEK** of operation.

7.3.2 Inspect for evidence of lube leakage.

7.3.3 Lubricant should be added to each gear mesh once a week, following the procedure in Section 6.

NOTE: COMPLIANCE WITH ALL APPLICABLE SAFETY CODES MUST BE OBSERVED AT ALL TIMES

8 GENERAL MAINTENANCE

Disassemble the spindle every six months. Thoroughly clean and inspect for gear tooth wear, spline wear, seal damage, wear of thrust buttons or other abnormal conditions which will affect the performance and life of the spindle. The presence of any unusual vibration, noise and/or overheating during operation or abnormal movement during the maintenance check should be thoroughly investigated to determine the cause. The possibility of loose fasteners or keys should be corrected if present.

Refer to Section 9 and reference Ameridrives Sales Drawing during disassembly and inspection.

Reassemble and lubricate the spindle in accordance with the instructions per Section 6.

9 DISASSEMBLY PROCEDURE

Refer to the Ameridrives Sales Drawing and Figures 3-1 through 3-6 for parts identification and relative position in the assembly. Partial disassembly is required at the drive end for spindle installation and removal.

Support the spindle components as required during disassembly and assembly. **DO NOT** permit the intermediate shaft assembly to rest on hub gear teeth. Protect all parts from damage. Lip seals will require extra care in handling to prevent damage.

CAUTION: IF THE SPINDLE HAS A TELESCOPIC INTERMEDIATE SHAFT (FIGURES 3-5 AND 3-6), DO NOT PLACE A SLING OR CHAIN AROUND THE SPLINE COVER WHEN LIFTING OR TRANSPORTING. ALWAYS HANDLE AND TRANSPORT IN A HORIZONTAL POSITION EXCEPT WHEN HANDLING A UNIT DESIGNED FOR VERTICAL APPLICATIONS.

9.1 Roll End and Drive End (Spindle design **WITHOUT** a spring pack)

WARNING: SOME ROLL END SPINDLE ASSEMBLIES ARE SPRING LOADED (SEE SALES DRAWING AND ROLL END OF FIGURES 3-1 THROUGH 3-6). THIS SPRING FORCE MUST BE OVERCOME PRIOR TO DISASSEMBLY. FOR SPINDLES WITH SPRING PACKS SEE SECTIONS 9.2 AND 9.3.

9.1.1 Remove OD fasteners and retainer. Place retainer on the hub barrel. See Figure 9-1.

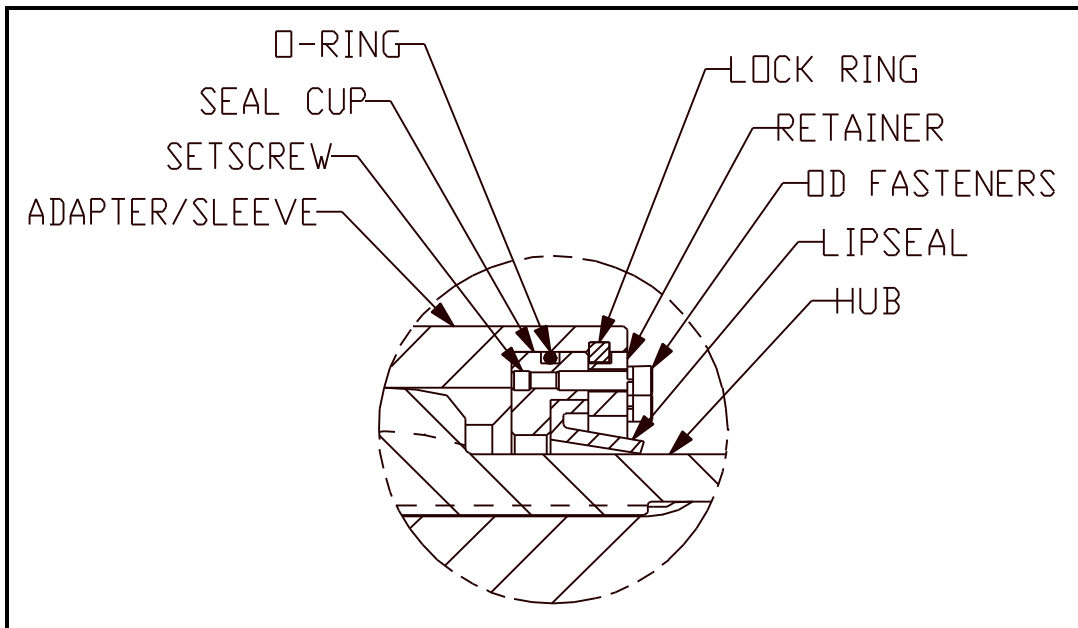

**Figure 9-1
Lock Ring**

- 9.1.2 Back-off setscrews in seal cup to relieve pressure on the lock ring. Remove lock ring, seal cup, and lip seal. Place these components on the hub barrel.

CAUTION: DAMAGE TO LOCK RING AND/OR ADAPTER/SLEEVE MAY RESULT IF SETSCREWS ARE NOT BACKED OUT.

- 9.1.3 Withdraw intermediate shaft out of roll end or drive end adapter/sleeve and place in supports taking care not to damage gear teeth.
- 9.1.4 Remove gear ring (when furnished) from adapter, see Figure 3-2.
- 9.1.5 It is not necessary to remove the assembled thrust button plate and thrust button unless the plate or button is damaged.
- 9.1.6 It is not necessary to remove hub, split retainer, hub retaining ring, thrust plate insert or o-ring seal from intermediate shaft except to replace worn or damaged parts or to inspect shaft and hub splines.

- 9.2 Roll End (Spindle design **WITH** a spring pack and split retainer for hub retention per Figures 3-1 through 3-3)

- 9.2.1 Remove OD fasteners and retainer. Place retainer on the hub barrel. See Figure 9-1.

WARNING: SOME ROLL END SPINDLE ASSEMBLIES ARE SPRING LOADED (SEE SALES DRAWING AND ROLL END OF FIGURES 3-1 THROUGH 3-3). THIS SPRING FORCE MUST BE OVERCOME PRIOR TO DISASSEMBLY.

- 9.2.2 Loosen hub fasteners as a set, maximum two (2) turns per screw until adapter/sleeve begins to droop. This relieves the spring force as the hub moves off the shaft.

- 9.2.3 Back-off setscrews in seal cup to relieve pressure on the lock ring. Remove lock ring, seal cup, and lip seal. Place these components on the hub barrel.

CAUTION: DAMAGE TO LOCK RING AND/OR ADAPTER/SLEEVE MAY RESULT IF SETSCREWS ARE NOT BACKED OUT.

- 9.2.4 Withdraw intermediate shaft out of roll end adapter/sleeve and place in supports taking care not to damage gear teeth.

- 9.2.5 Remove gear ring (when furnished) from adapter, see Figure 3-2.

- 9.2.6 It is not necessary to remove the assembled thrust button plate and thrust button unless the plate or button is damaged.

- 9.2.7 It is not necessary to remove hub, split retainer, thrust plate insert or o-ring seal from intermediate shaft except to replace worn or damaged parts or to inspect shaft and hub splines.

- 9.3 Roll End (Spindle design **WITH** a spring pack and retaining ring for hub retention per Figure 3-4)

- 9.3.1 Remove OD fasteners and retainer. Support retainer on the intermediate shaft, see Figure 9-1.

WARNING: SOME ROLL END SPINDLE ASSEMBLIES ARE SPRING LOADED, (SEE SALES DRAWING AND ROLL END OF FIGURE 3-4). THIS SPRING FORCE MUST BE OVERCOME PRIOR TO DISASSEMBLY.

- 9.3.2 Place a sling around the intermediate shaft near the drive end hub. Carefully raise the spindle with an overhead crane into a vertical position and lower to the floor. The weight of the intermediate shaft will compress the spring pack and allow further disassembly. Care should be taken not to damage gear teeth.

CAUTION: IF THE SPINDLE IS EQUIPPED WITH A TELESCOPIC INTERMEDIATE SHAFT, THE SHAFT SHOULD BE EXTENDED PRIOR TO LIFTING INTO A VERTICAL POSITION.

- 9.3.3 Back-off setscrews in seal cup to relieve pressure on the lock ring. Remove lock ring, seal cup, and lip seal. Support these components on the intermediate shaft.

CAUTION: DAMAGE TO LOCK RING AND/OR ADAPTER/SLEEVE MAY RESULT IF SETSCREWS ARE NOT BACKED OUT.

- 9.3.4 Lift intermediate shaft out of roll end adapter/sleeve and place in supports taking care not to damage gear teeth.

- 9.3.5 Remove gear ring (when furnished) from adapter.

- 9.3.6 It is not necessary to remove the assembled thrust button plate and thrust button unless the plate or button is damaged.

- 9.3.7 It is not necessary to remove hub retaining ring, hub, thrust plate insert or o-ring seal from intermediate shaft except to replace worn or damaged parts.

- 9.4 Disassembly of Intermediate Telescopic Shaft, With Snubber Screws (see Figure 3-5).
 - 9.4.1 Always apply easily visible matchmarks on the male and female telescopic spline components of the intermediate shaft before total disassembly. This will assure proper alignment when reassembled.
 - 9.4.2 Remove two (2) lube plugs/reducers and extend the travel until the two (2) snubber screws are visible and remove. Continue to extend the travel to fully disassemble.
- 9.5 Disassembly of Intermediate Telescopic Shaft, With Snubber Plate (see Figure 3-6).
 - 9.5.1 Always apply easily visible matchmarks on the male and female telescopic spline components of the intermediate shaft before total disassembly. This will assure proper alignment when reassembled.
 - 9.5.2 Fully collapse travel of intermediate shaft. Remove retaining ring in the inner diameter of telescopic hub and the thrust plate insert. This provides access to the snubber plate hardware and the snubber plate.
 - 9.5.3 Remove the snubber plate hardware and the snubber plate. Fully extend the travel to disassemble.
- 9.6 Reassemble reversing the procedures in Sections 9.1 through 9.5.

10 ORDERING INFORMATION

When returning a spindle for overhaul or to order replacement parts, please contact our Mill Products Group at: Group at ***our new address or call us at our new phone listed below, our fax remains the same:***

Ameridrives International
Coupling Products
P.O. Box 4000
1802 Pittsburgh Ave.
Erie, Pennsylvania USA 16512-4000
Phone: 814/480-5000
Fax: 814/453-5891

Please provide the following information:

Size and type of Spindle.
Ameridrives sales drawing number.
Part number, name and quantity of each part.