

Ameriflex[®] Diaphragm Couplings

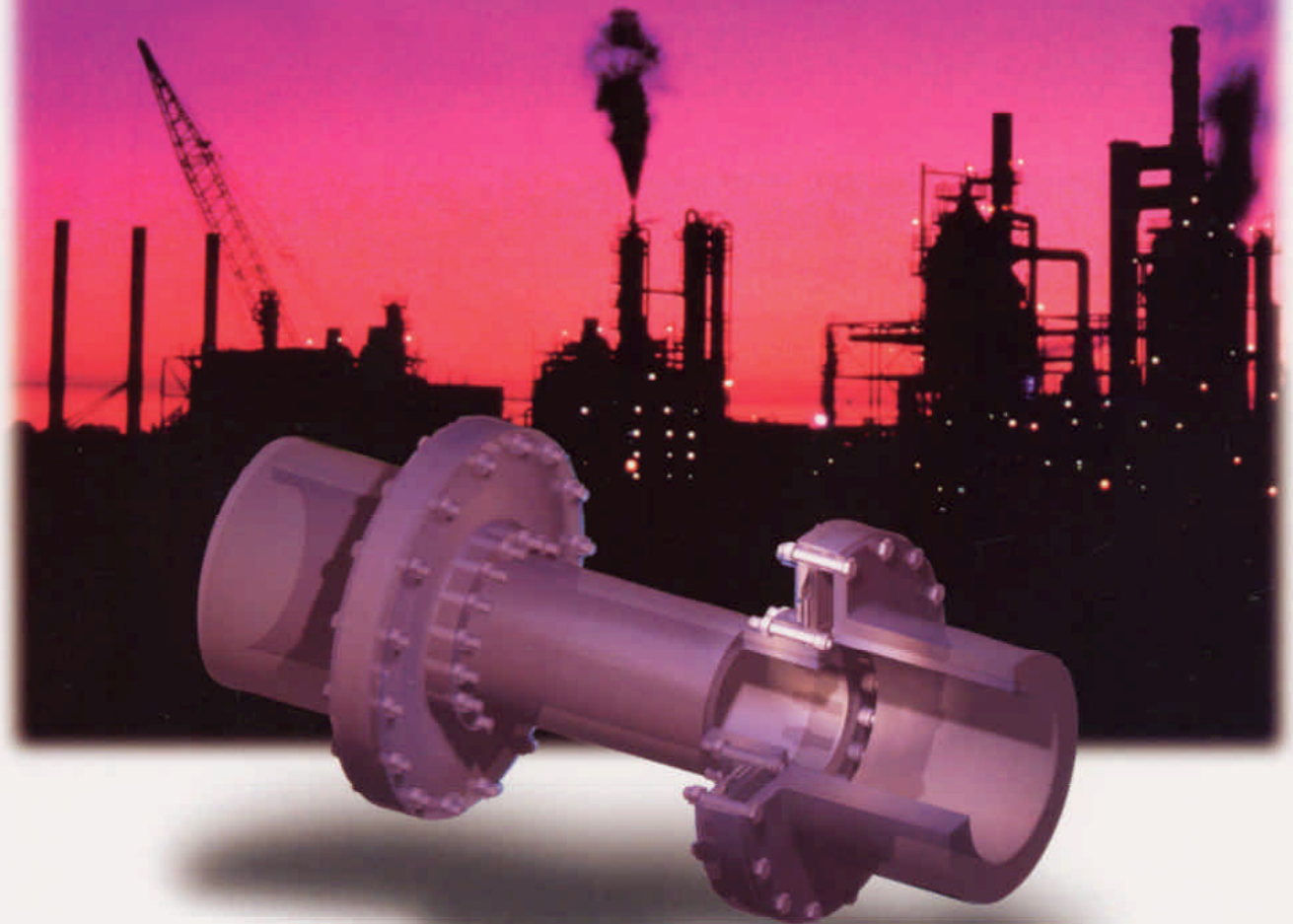

Series NC
For High Performance Applications

Ameridrives[®] Couplings

Boston

Ameriflex®

Diaphragm Couplings NC Series

Ameridrives International's reputation has been built on specialized designs for demanding applications. We are now pleased to offer the industry another diaphragm coupling for a wider range of applications.

Designed specifically for the rigorous demands of the turbomachinery industry, the Ameriflex multiple convoluted diaphragm coupling was introduced in 1971. Since then, continuous refinements have made Ameriflex the industry leader in reliability and design flexibility. The new NC Series Ameriflex was developed as a natural extension of our proven designs, using the latest engineering technologies.

Fewer parts combined with modern manufacturing techniques, result in a cost-effective coupling while maintaining the same quality and performance standards proven by over 25 years experience with thousands of Ameriflex operating trouble-free.

- Simplified, economical design (Figure 1)
- Meets API-671 requirements
- Diaphragms designed for infinite life using FEA verified by strain gage and dynamic testing (Figure 2)
- 15-5 PH integral filler diaphragms maintain flex area separation
- 1/4 degree misalignment
- Low axial and bending stiffness
- Piloted construction for low repeatable unbalance
- Maintenance free for years of dependable service

Figure 1

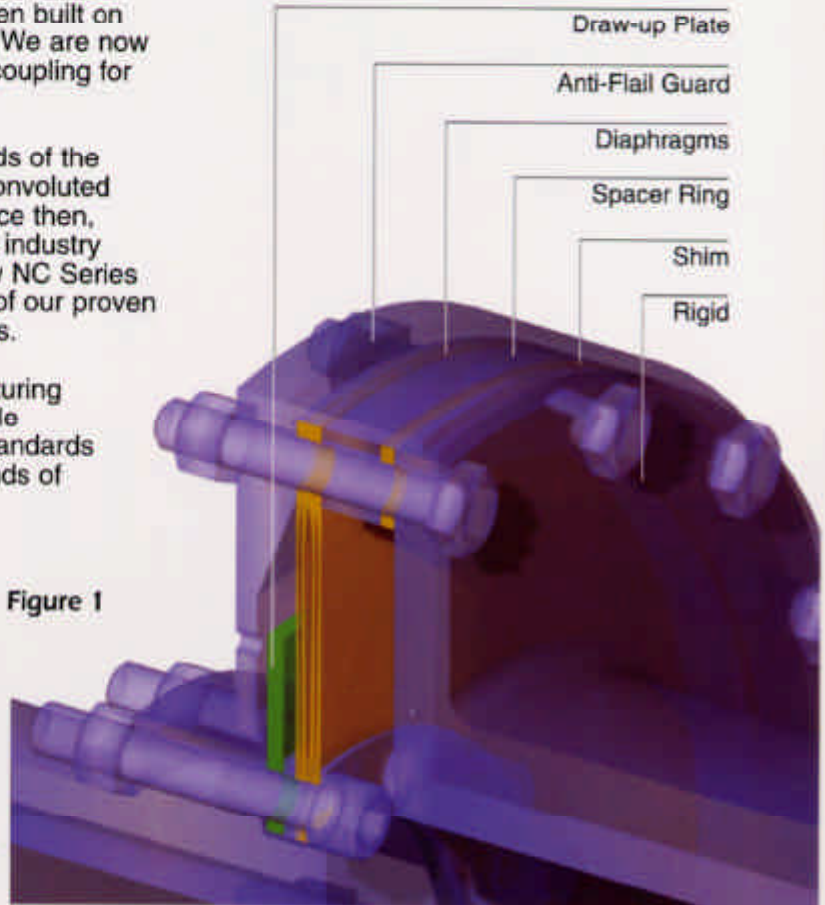

Figure 2



Ameridrives International
Coupling Products



Member: API
AGMA
PTRA
PTDA

Caution: Rotating equipment is potentially dangerous and could cause injury or damage if not properly protected. Follow applicable codes and regulations.

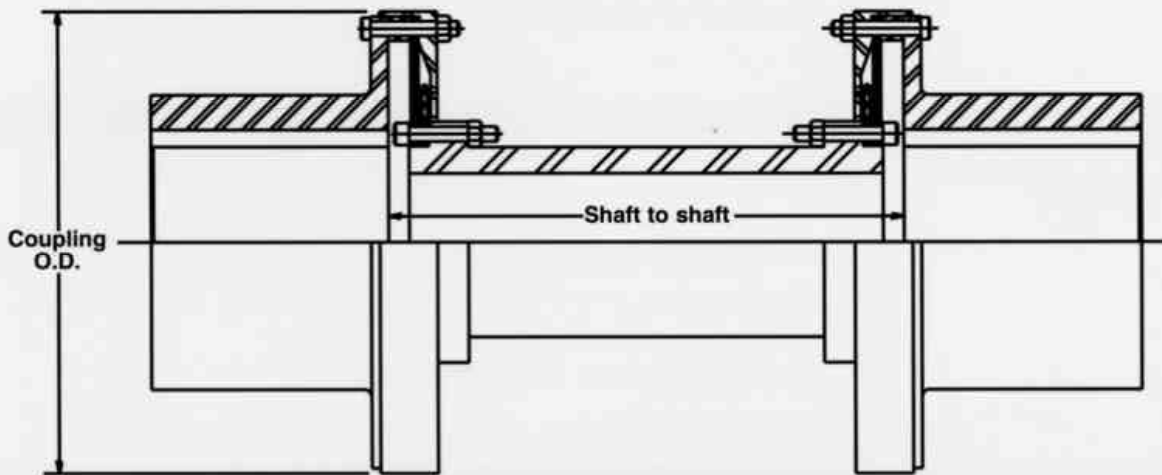

Coupling Data - NC Series

| Coupling Size | Max. Cont. Torque (in. - lb.) | Peak Torque (in.- lb.) | Rated Speed (RPM) | Max. Axial Travel (in.) | Coupling O.D. (in.) | Shaft to Shaft Min. (in.) | Bore Diam. Max. (in.) |
|---------------|-------------------------------|------------------------|-------------------|-------------------------|---------------------|---------------------------|-----------------------|
| 7 | 53,000 | 80,000 | 10,000 | .050 | 7.12 | 5.06 | 4.00 |
| 9 | 120,000 | 180,000 | 10,000 | .090 | 9.81 | 5.75 | 5.50 |
| 11 | 210,000 | 315,000 | 10,000 | .120 | 11.75 | 5.94 | 6.50 |
| 13 | 333,000 | 500,000 | 8,000 | .140 | 13.56 | 7.63 | 7.75 |
| 15 | 500,000 | 750,000 | 8,000 | .160 | 15.56 | 7.81 | 9.00 |

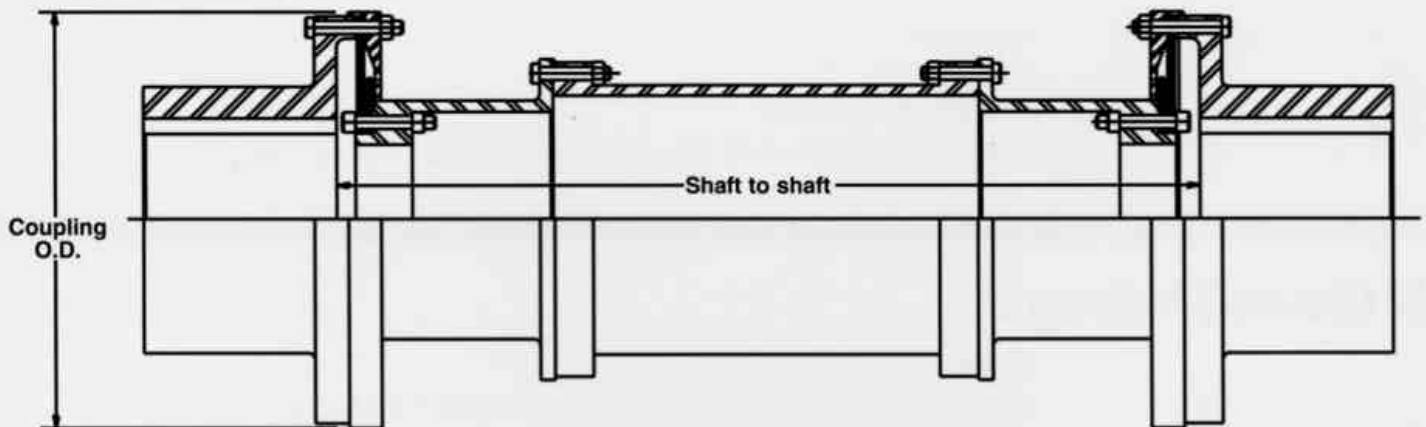

Coupling Data - NCS Series

| Coupling Size | Max. Cont. Torque (in. - lb.) | Peak Torque (in.- lb.) | Rated Speed (RPM) | Max. Axial Travel (in.) | Coupling O.D. (in.) | Shaft to Shaft Min. (in.) | Bore Diam. Max. (in.) |
|---------------|-------------------------------|------------------------|-------------------|-------------------------|---------------------|---------------------------|-----------------------|
| 7 | 53,000 | 80,000 | 10,000 | .050 | 7.12 | 12.88 | 4.00 |
| 9 | 120,000 | 180,000 | 10,000 | .090 | 9.81 | 13.75 | 5.50 |
| 11 | 210,000 | 315,000 | 10,000 | .120 | 11.75 | 14.63 | 6.50 |
| 13 | 333,000 | 500,000 | 8,000 | .140 | 13.56 | 15.50 | 7.75 |
| 15 | 500,000 | 750,000 | 8,000 | .160 | 15.56 | 16.38 | 9.00 |

*Note: All torque ratings at .25° misalignment and maximum axial travel.

Ameridrives International recommends a 1.0 service factor for constant torque applications, 1.5 for motor driven applications, and 2.0 for moderate torque fluctuations. API-671 recommends a 1.5 service factor for flexible element couplings.

Ameridrives® Couplings

PO Box 4000
Erie PA USA 16512 4000
Tel 814 480 5000
Fax 814 453 5891
www.ameridrives.com

Ameriflex® Diaphragm Couplings
Amerigear® Gear Couplings
Amerigear® Mill Spindles
Americardan® Universal Joints

Bay City Forge

PO Box 4000
Erie PA USA 16512 4000
Tel 814 456 2088
Fax 814 456 4395
www.baycityforge.com

Single and Multiple Crankshafts
Straight, Eccentric and Hollow Bore Shafts
Round, Square and Hex Bar Stock
Rolls, Spindles, Upsets, Rings and Disks

Industrial Clutch

PO Box 118
Waukesha WI USA 53187 0118
Tel 414 547 3357
Fax 414 547 2949
www.indclutch.com

Model LKB Low Inertia Clutches & Brakes
Model CBA/CBH Combination Clutch/Brake
Model HC, HBA, HBS Oil Cooled Clutches & Brakes

Marland Clutch

PO Box 308
La Grange IL USA 60525 0308
Tel 708 352 3330
Fax 708 352 1403
www.marland.com

Marland Backstops
CECON® Clutches
CEBMAG® Clutches
Marland RINGSPANN® Freewheel Clutches

Nuttall Gear/Delroyd®

PO Box 1032
Niagara Falls NY USA 14302 1032
Tel 716 731 5180
Fax 716 731 9329
www.nuttallgear.com

Delroyd® Worm Gear Products
Type TDS Parallel & Right Angle Shaft Speed Reducers
Moduline® Concentric Shaft Speed Reducers & Gearmotors
Type SU & Type SD High Speed Gear Drives
Type RV Right Angle Vertical Speed Reducers
Veri-Dri Vertical Concentric and Parallel Shaft Drives
Metals Industry Gear Drives
Custom Engineered Drives

Contact your nearest representative.

