

AMPEP

High performance plain bearings

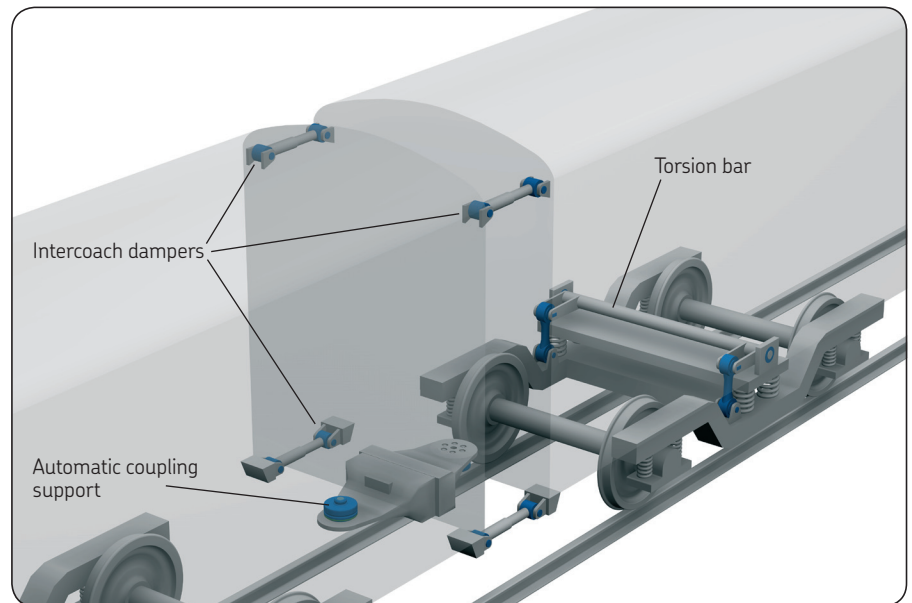

The particular dynamic stresses in railway bogies demand special solutions such as high performance self-lubricating plain bearings.

These bearings are excellent solutions for applications where bearing pressures are high, movement slow and maintenance is difficult or even impossible. In rail bogies, self-lubricating plain bearings are used for torsion bars, damper attachment points, swing links, brake mechanisms, steering linkages, valve linkages, and automatic couplers as well as for tilt mechanisms of high-speed tilting trains.

AMPEP self-lubricating spherical plain bearings are high quality products that provide a low coefficient of friction combined with low wear rates. This is achieved by using woven polytetrafluoroethylene (PTFE) and glass fibres. Typically used in high-speed trains, AMPEP bearings are also used in locomotives, and passenger and mass transit vehicles like low-floor tramways.

AMPEP bearing benefits

- low friction and wear, minimal stick slip
- low life cycle cost
- excellent for oscillatory applications
- virtually maintenance-free, self-lubricating
- wide operating temperature range, from -50 up to $+200$ °C



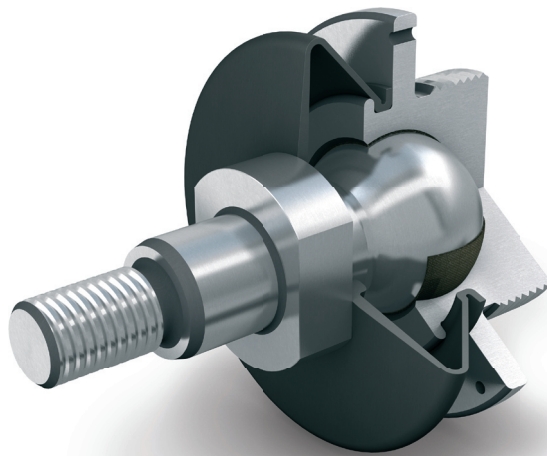
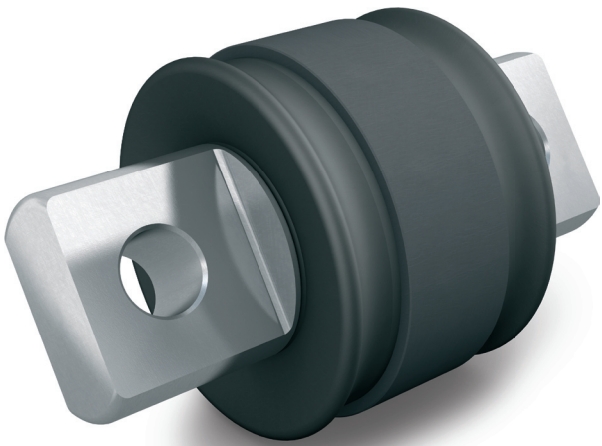
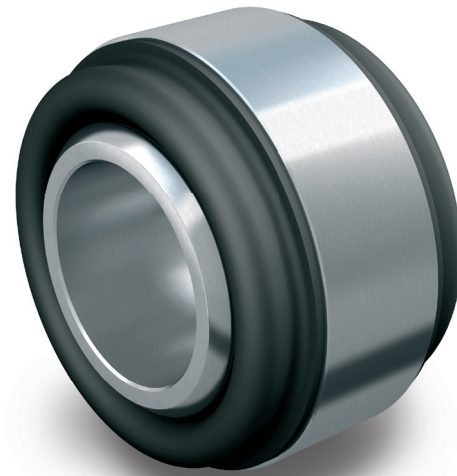
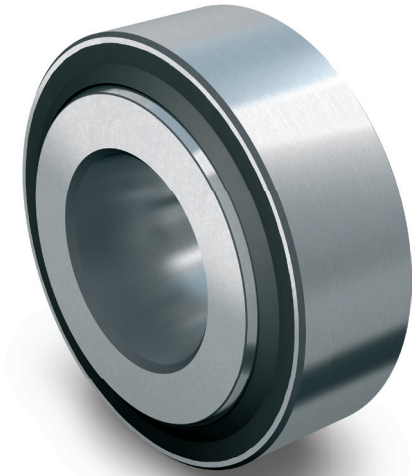

*Top left: Plain spherical bearing assembly with lip seals
Top right: Sealed spherical bearing assembly
Bottom left: Sealed ball pin assembly
Bottom right: Sealed ball joint assembly*

Bearing capabilities

To meet the stringent requirements previously defined, the AMPEP solution is based on a low friction coefficient combined with sliding materials with low wear rates. The one-piece outer ring is formed around the spherical shape of the inner ring during the manufacturing process and contains no splits or loader slots. This provides excellent conformity of the mating surfaces.

AMPEP bearings are used for railway bogies as well as for aerospace applications where these bearings are approved by the European Aviation Safety Agency (EASA) and are designed in accordance with ISO 9002 and Aerospace Sector Certification Scheme TS 157.

Technical features

Main components of an AMPEP spherical plain bearing are:

- a one-piece outer ring
- a PTFE/glass fibre liner
- a ball or spherical inner ring

The surfaces are continuously lubricated by a film of PTFE during the entire life of the bearing.

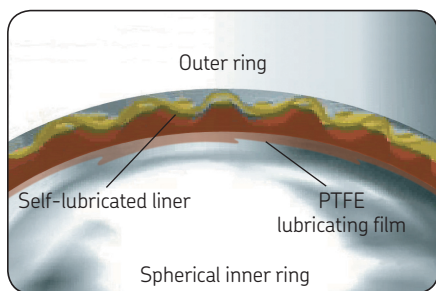

AMPEP spherical plain bearing, design principal features

Liner systems

To meet the various life requirements of different applications AMPEP offer a number of bearing liner systems.

AMPEP X1

The bearing liner AMPEP X1 is based on a woven polytetrafluoroethylene (PTFE) / glass fabric, laminated under heat and pressure with a phenolic resin-impregnated glass cloth. The oscillating movement of the bearing causes the spherical surface to be continuously lubricated with a film of PTFE during the life of the bearing, which provides a low coefficient of friction combined with low wear rates.

Various liner counterface combinations have different performance levels and can satisfy very stringent application criteria.

The AMPEP X1 liner system is qualified to American Aerospace Standard SAE AS81820 and is extensively used in aerospace and industrial applications.

AMPEP XLHP and XL

The AMPEP XL and latest generation XLHP bearings are the result of an extensive development programme to produce acceptable lifespan in arduous aerospace

applications. They exceed international standards by a considerable margin, thus providing long life and reliability. The AMPEP XLHP and XL liner system employs super finished hard coatings on the counterface. Counterface variants include super finished through hardened steel, hard chrome and other coatings appropriate to the application and performance required. The bearings are manufactured from high-quality carbon or corrosion-resistant steel to meet the demand for high reliability and low life cycle cost.

AMPEP XLNT

To further extend the life of AMPEP bearings, the AMPEP XLNT ceramic system has been introduced, which provides a significant increase in the wear resistance of many bearing applications, further improving service life and reliability.

Liner wear comparison

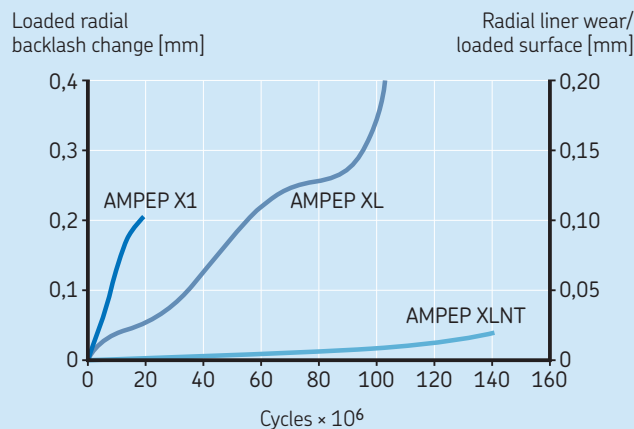

Frequency	6 Hz
Radial load	± 240 daN sinusoidal
Sliding velocity	0,046 m/sec
Radial projected stress	14,8 Mpa
Motion	± 11° oscillation ± 5° misalignment

Wear characteristics

Liner wear is primarily a function of bearing pressure, surface velocity and sliding distance at a given temperature. Other determining life factors are:

- **Surface finish of liner counterface**, life increases with improved surface finish.
- **Hardness of the liner counterface**, generally, the harder the surface the longer the life of the bearing. The surface should be hardened and corrosion resistant.
- **Good conformity** of the contact area between the liner and counterface is essential to maximize bearing life.
- **Absence of contaminants**, which otherwise increases wear. If water contamination is likely, the bearing should be sealed.

In a typical reversing load application, most rail applications require a wear limit of 0,125 mm per liner surface (0,25 mm of backlash). If the application is loaded primarily in one direction, the amount of acceptable backlash is restricted to the wear of one liner surface (0,125 mm). However, it is essential that an accurate analysis of the

duty cycle of any particular application is performed if a service life is to be realistically predicted and obtained.

General operating guidance

- **dynamic load** refers to steady loads with movement at the bearing surface
 - mean dynamic pressure from 3,5 up to 35 MPa
 - maximum dynamic operating pressure of 70 MPa
- **static load** implies a steady applied force with no movement of the sliding surfaces with respect to each other:
 - maximum static operating pressure of 140 MPa
 - maximum static bearing pressure of 280 MPa
- **surface velocity** up to 0,1 m/s
- **operating temperature** range from -50 up to +200 °C

Application features

Wear in the bearing occurs as a result of movement between the mating surfaces under pressure. An accurate analysis of the duty cycle in any particular application is essential if an operating life is to be realistically predicted and obtained. In a typical

rail bogie suspension system where extended lives are required, bearing pressures of 3,5 to 20 MPa are encountered, together with angles of oscillation of $\pm 1^\circ$ at 30 Hz to $\pm 5^\circ$ at 0,1 Hz. Under these demanding conditions, operating lives in excess of 2,2 million kilometres of travel are obtained.

For continuous running, it is recommended that surface velocities should not exceed 0,1 m/s. In applications where operation is intermittent, higher velocities may be tolerated. Temperature limits range from -50 up to 200 °C. However, wear rates are increased at the higher and lower temperatures.

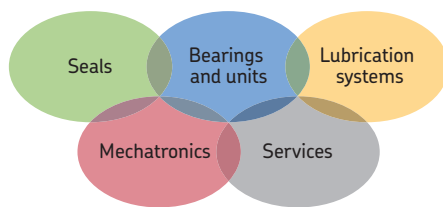

The Power of Knowledge Engineering

Drawing on five areas of competence and application-specific expertise amassed over more than 100 years, SKF brings innovative solutions to OEMs and production facilities in every major industry worldwide. These five competence areas include bearings and units, seals, lubrication systems, mechatronics (combining mechanics and electronics into intelligent systems), and a wide range of services, from 3-D computer modelling to advanced condition monitoring and reliability and asset management systems. A global presence provides SKF customers uniform quality standards and worldwide product availability.

© SKF and AMPEP are registered trademarks of the SKF Group.

© SKF Group 2012

The contents of this publication are the copyright of the publisher and may not be reproduced (even extracts) unless prior written permission is granted. Every care has been taken to ensure the accuracy of the information contained in this publication but no liability can be accepted for any loss or damage whether direct, indirect or consequential arising out of the use of the information contained herein.

PUB 42/P2 13089 EN · September 2012

Printed in Sweden on environmentally friendly paper.

