

# **CARTER** offers an outstanding source for your Precision Bearing needs...

## **About Carter Manufacturing Company:**

Carter is a dynamic young company specializing in the manufacture of precision bearings. Because of our size we have great flexibility in our shop, and are frequently able to offer bearings more quickly and at lower costs than larger bearing manufacturers. We are small enough to handle each order on a personal basis, yet large enough to handle substantial bearing needs.

## **Research and Development:**

With the development of our new line of Sealed Anti-Friction Needle Roller Bearings and our Neverlube Bearings with Perma-Flow Lubrication, coupled with our ability to quickly meet the demands of our customer base, Carter Manufacturing has seen rapid and consistent growth.

## **The Carter Advantage:**

- ◆ Ready Availability of all standard sizes from stock, or on a prompt delivery basis
- ◆ Interchangeability with the standard types of other leading bearing manufacturers
- ◆ Fast Deliveries on other “specials” or modifications of standard bearings to meet your particular bearing needs

<b>Information</b>	<b>Page Number</b>
Needle Bearing Cam Followers	2 & 3
Needle Bearing Cam Followers - Crowned	4
Needle Bearing Cam Followers - Eccentric	5 & 6
Needle Bearing Cam Followers – Eccentric, Crowned	7
Needle Bearing Cam Followers - Heavy Duty	8 & 9
Needle Bearing Cam Followers - Heavy Duty, Crowned	10
Needle Bearing Cam Yoke Rollers	11
Needle Bearing Interchangeability Chart	12
Stainless Steel Cam Followers - Xtenda Series	13
Stainless Steel Cam Yoke Rollers - Xtenda Series	14
Needle Bearing Application Data	15
Dimension Chart	16
Neverlube Cam Followers	17
Neverlube Cam Followers - Eccentric	18
Neverlube Cam Yoke Rollers	19
Neverlube Application Data	20
Neverlube Information	21
Hi-Roller Series	22 – 24

# Needle Bearing Cam Followers

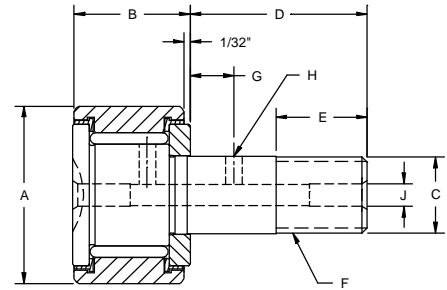

## Needle Bearing Cam Followers

Slotted																
Part Number			Roller		Stud				Lubrication			Other Specs.				
Size	Unsealed	Sealed	A	B	C	D	E	F	G	H	J	Min. Boss Dia.	Recom. Bore +.0005 -.0000	**Recom. Torque Inch Pounds	Max Static Capacity Pounds	Basic Dynamic Rating Pounds
			Roller O.D. +.000 -.001	Roller Width +.000 -.005	Stud Dia. +.001 -.000	Stud Length +.010 -.010	Min. Eff Thread Length +.030 -.030	Thread Class 2A	Oil Hole Center	Oil Hole Dia.	Lube Fitting Size					
1/2	CNB-16-N	CNB-16-NS	.500	.344	.190	.500	.250	10-32	~	~	*1/8	19/64	.1900	15	790	680
1/2	CNB-16	CNB-16-S	.500	.375	.190	.625	.250	10-32	~	~	*1/8	19/64	.1900	15	790	680
5/8	CNB-20-N	CNB-20-NS	.625	.406	.250	.625	.312	1/4-28	~	~	*1/8	23/64	.2500	35	1215	995
5/8	CNB-20	CNB-20-S	.625	.4375	.250	.750	.312	1/4-28	~	~	*1/8	23/64	.2500	35	1215	995
11/16	CNB-22	CNB-22-S	.6875	.4375	.250	.750	.312	1/4-28	~	~	*1/8	23/64	.2500	35	1215	955
3/4	CNB-24	CNB-24-S	.750	.500	.375	.875	.375	3/8-24	1/4	3/32	3/16	1/2	.3750	95	2065	1660
7/8	CNB-28	CNB-28-S	.875	.500	.375	.875	.375	3/8-24	1/4	3/32	3/16	1/2	.3750	95	2065	1660
1	CNB-32	CNB-32-S	1.000	.625	.4375	1.000	.500	7/16-20	1/4	3/32	3/16	5/8	.4375	250	3060	2225
1 1/8	CNB-36	CNB-36-S	1.125	.625	.4375	1.000	.500	7/16-20	1/4	3/32	3/16	5/8	.4375	250	3060	2225
1 1/4	CNB-40	CNB-40-S	1.250	.750	.500	1.250	.625	1/2-20	5/16	3/32	3/16	3/4	.5000	350	4250	3930
1 3/8	CNB-44	CNB-44-S	1.375	.750	.500	1.250	.625	1/2-20	5/16	3/32	3/16	3/4	.5000	350	4250	3930
1 1/2	CNB-48	CNB-48-S	1.500	.875	.625	1.500	.750	5/8-18	3/8	3/32	3/16	57/64	.6250	650	5640	4840
1 5/8	CNB-52	CNB-52-S	1.625	.875	.625	1.500	.750	5/8-18	3/8	3/32	3/16	57/64	.6250	650	5640	4840
1 3/4	CNB-56	CNB-56-S	1.750	1.000	.750	1.750	.875	3/4-16	7/16	3/32	3/16	1 3/64	.7500	1250	7920	6385
1 7/8	CNB-60	CNB-60-S	1.875	1.000	.750	1.750	.875	3/4-16	7/16	3/32	3/16	1 3/64	.7500	1250	7920	6385
2	CNB-64	CNB-64-S	2.000	1.250	.875	2.000	1.000	7/8-14	1/2	1/8	3/16	1 13/64	.8750	1500	10570	8090
2 1/4	CNB-72	CNB-72-S	2.250	1.250	.875	2.000	1.000	7/8-14	1/2	1/8	3/16	1 13/64	.8750	1500	10570	8090
2 1/2	CNB-80	CNB-80-S	2.500	1.500	1.000	2.250	1.125	1-14	9/16	1/8	3/16	1 5/16	1.0000	2250	16450	11720
2 3/4	CNB-88	CNB-88-S	2.750	1.500	1.000	2.250	1.125	1-14	9/16	1/8	3/16	1 5/16	1.0000	2250	16450	11720
3	CNB-96	CNB-96-S	3.000	1.750	1.250	2.500	1.250	1 1/4-12	5/8	1/8	1/4	1 3/4	1.2500	3450	24910	15720
3 1/4	CNB-104	CNB-104-S	3.250	1.750	1.250	2.500	1.250	1 1/4-12	5/8	1/8	1/4	1 3/4	1.2500	3450	24910	15720
3 1/2	CNB-112	CNB-112-S	3.500	2.000	1.375	2.750	1.375	1 3/8-12	11/16	1/8	1/4	1 59/64	1.3750	4200	31625	22800
4	CNB-128	CNB-128-S	4.000	2.250	1.500	3.500	1.500	1 1/2-12	3/4	1/8	1/4	2 9/32	1.5000	5000	44770	29985

\*Relubricate through head end only. Lubrication information – see page 15

\*\*Clamping torque is based on dry threads. If threads are lubricated, use half of values shown

# Needle Bearing Cam Followers

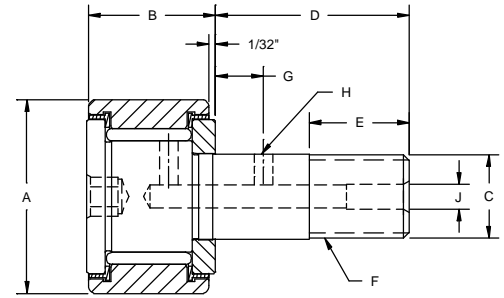

## Needle Bearing Cam Followers

Hexed																
Part Number			Roller		Stud				Lubrication			Other Specs.				
			A	B	C	D	E	F	G	H	J					
Size	Unsealed	Sealed	Roller O.D +.000 -.001	Roller Width +.000 -.005	Stud Dia. +.001 -.000	Stud Length +.010 -.010	Min. Eff. Thread Length +.030 -.030	Thread Class 2A	Oil Hole Center	Oil Hole Dia.	Lube Fitting Size	Min. Boss Dia.	Recom. Bore +.0005 -.0000	**Recom. Torque Inch Pounds	Max. Static Capacity Pounds	Basic Dynamic Rating Pounds
1/2	CNB-16-NB	CNB-16-NSB	.500	.344	.190	.500	.250	10-32	~	~	*1/8	19/64	.1900	15	790	680
1/2	CNB-16-B	CNB-16-SB	.500	.375	.190	.625	.250	10-32	~	~	*1/8	19/64	.1900	15	790	680
5/8	CNB-20-NB	CNB-20-NSB	.625	.406	.250	.625	.312	1/4-28	~	~	*1/8	23/64	.2500	35	1215	995
5/8	CNB-20-B	CNB-20-SB	.625	.4375	.250	.750	.312	1/4-28	~	~	*1/8	23/64	.2500	35	1215	995
11/16	CNB-22-B	CNB-22-SB	.6875	.4375	.250	.750	.312	1/4-28	~	~	*1/8	23/64	.2500	35	1215	955
3/4	CNB-24-B	CNB-24-SB	.750	.500	.375	.875	.375	3/8-24	1/4	3/32	3/16	1/2	.3750	95	2065	1660
7/8	CNB-28-B	CNB-28-SB	.875	.500	.375	.875	.375	3/8-24	1/4	3/32	3/16	1/2	.3750	95	2065	1660
1	CNB-32-B	CNB-32-SB	1.000	.625	.4375	1.000	.500	7/16-20	1/4	3/32	3/16	5/8	.4375	250	3060	2225
1 1/8	CNB-36-B	CNB-36-SB	1.125	.625	.4375	1.000	.500	7/16-20	1/4	3/32	3/16	5/8	.4375	250	3060	2225
1 1/4	CNB-40-B	CNB-40-SB	1.250	.750	.500	1.250	.625	1/2-20	5/16	3/32	3/16	3/4	.5000	350	4250	3930
1 3/8	CNB-44-B	CNB-44-SB	1.375	.750	.500	1.250	.625	1/2-20	5/16	3/32	3/16	3/4	.5000	350	4250	3930
1 1/2	CNB-48-B	CNB-48-SB	1.500	.875	.625	1.500	.750	5/8-18	3/8	3/32	3/16	57/64	.6250	650	5640	4840
1 5/8	CNB-52-B	CNB-52-SB	1.625	.875	.625	1.500	.750	5/8-18	3/8	3/32	3/16	57/64	.6250	650	5640	4840
1 3/4	CNB-56-B	CNB-56-SB	1.750	1.000	.750	1.750	.875	3/4-16	7/16	3/32	3/16	1 3/64	.7500	1250	7920	6385
1 7/8	CNB-60-B	CNB-60-SB	1.875	1.000	.750	1.750	.875	3/4-16	7/16	3/32	3/16	1 3/64	.7500	1250	7920	6385
2	CNB-64-B	CNB-64-SB	2.000	1.250	.875	2.000	1.000	7/8-14	1/2	1/8	3/16	1 13/64	.8750	1500	10570	8090
2 1/4	CNB-72-B	CNB-72-SB	2.250	1.250	.875	2.000	1.000	7/8-14	1/2	1/8	3/16	1 13/64	.8750	1500	10570	8090
2 1/2	CNB-80-B	CNB-80-SB	2.500	1.500	1.000	2.250	1.125	1-14	9/16	1/8	3/16	1 5/16	1.0000	2250	16450	11720
2 3/4	CNB-88-B	CNB-88-SB	2.750	1.500	1.000	2.250	1.125	1-14	9/16	1/8	3/16	1 5/16	1.0000	2250	16450	11720
3	CNB-96-B	CNB-96-SB	3.000	1.750	1.250	2.500	1.250	1 1/4-12	5/8	1/8	1/4	1 3/4	1.2500	3450	24910	15720
3 1/4	CNB-104-B	CNB-104-SB	3.250	1.750	1.250	2.500	1.250	1 1/4-12	5/8	1/8	1/4	1 3/4	1.2500	3450	24910	15720
3 1/2	CNB-112-B	CNB-112-SB	3.500	2.000	1.375	2.750	1.375	1 3/8-12	11/16	1/8	1/4	1 59/64	1.3750	4200	31625	22800
4	CNB-128-B	CNB-128-SB	4.000	2.250	1.500	3.500	1.500	1 1/2-12	3/4	1/8	1/4	2 9/32	1.5000	5000	44770	29985
5	~	CNB-160-SB	5.000	2.750	2.000	5.062	2.562	2-12	7/8	3/16	1/4 N.P.T.	2 7/8	2.0000	5000	67950	46575
6	~	CNB-192-SB	6.000	3.250	2.500	6.000	3.000	2 1/2-12	1	3/16	1/4 N.P.T.	3 3/8	2.5000	5000	80450	60000
7	~	CNB-224-SB	7.000	3.750	3.000	7.687	4.125	3-12	1 1/4	3/16	1/4 N.P.T.	3 7/8	3.0000	5000	106930	75380
8	~	CNB-256-SB	8.000	4.250	3.250	8.500	4.258	3 1/4-4	~	~	1/4 N.P.T.	4 3/4	3.2500	5000	144100	92200
9	~	CNB-288-SB	9.000	4.750	3.750	9.500	4.750	3 1/2-4	~	~	1/4 N.P.T.	5 7/16	3.7500	5000	183430	113260
10	~	CNB-320-SB	10.000	5.250	4.250	10.000	4.750	3 1/2-4	~	~	1/4 N.P.T.	5 59/64	4.2500	5000	215565	131545

\*Relubricate through head end only. Lubrication information – see page 15  
 \*\*Clamping torque is based on dry threads. If threads are lubricated, use half of values shown

# Needle Bearing Cam Followers - Crowned

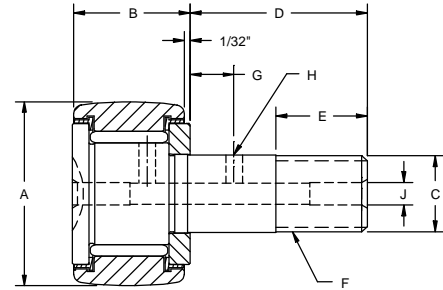

Needle Bearing Cam Followers- Crowned																
Sealed – Slotted & Hexed																
Part Number			Roller		Stud				Lubrication			Other Specs.				
			A	B	C	D	E	F	G	H	J					
Size	Sealed & Slotted With Crowned O.D.	Sealed & Hexed With Crowned O.D.	Roller O.D. +.000 -.001	Roller Width +.000 -.005	Stud Dia. +.001 -.000	Stud Length +.010 -.010	Min. Eff. Thread Length +.030 -.030	Thread Class 2A	Oil Hole Center	Oil Hole Dia.	Lube Fitting Size	Min. Boss Dia.	Recom. Bore +.0005 -.0000	**Recom. Torque Inch Pounds	Max. Static Capacity Pounds	Basic Dynamic Rating Pounds
1/2	CCNB-16-NS	CCNB-16-NSB	.500	.345	.190	.500	.250	10-32	~	~	*1/8	19/64	.1900	15	790	680
1/2	CCNB-16-S	CCNB-16-SB	.500	.375	.190	.625	.250	10-32	~	~	*1/8	19/64	.1900	15	790	680
5/8	CCNB-20-NS	CCNB-20-NSB	.625	.406	.250	.625	.312	1/4-28	~	~	*1/8	23/64	.2500	35	1215	995
5/8	CCNB-20-S	CCNB-20-SB	.625	.4375	.250	.750	.312	1/4-28	~	~	*1/8	23/64	.2500	35	1215	995
11/16	CCNB-22-S	CCNB-22-SB	.6875	.4375	.250	.750	.312	1/4-28	~	~	*1/8	23/64	.2500	35	1215	955
3/4	CCNB-24-S	CCNB-24-SB	.750	.500	.375	.875	.375	3/8-24	1/4	3/32	3/16	1/2	.3750	95	2065	1660
7/8	CCNB-28-S	CCNB-28-SB	.875	.500	.375	.875	.375	3/8-24	1/4	3/32	3/16	1/2	.3750	95	2065	1660
1	CCNB-32-S	CCNB-32-SB	1.000	.625	.4375	1.000	.500	7/16-20	1/4	3/32	3/16	5/8	.4375	250	3060	2225
1 1/8	CCNB-36-S	CCNB-36-SB	1.125	.625	.4375	1.000	.500	7/16-20	1/4	3/32	3/16	5/8	.4375	250	3060	2225
1 1/4	CCNB-40-S	CCNB-40-SB	1.250	.750	.500	1.250	.625	1/2-20	5/16	3/32	3/16	3/4	.5000	350	4250	3930
1 3/8	CCNB-44-S	CCNB-44-SB	1.375	.750	.500	1.250	.625	1/2-20	5/16	3/32	3/16	3/4	.5000	350	4250	3930
1 1/2	CCNB-48-S	CCNB-48-SB	1.500	.875	.625	1.500	.750	5/8-18	3/8	3/32	3/16	57/64	.6250	650	5640	4840
1 5/8	CCNB-52-S	CCNB-52-SB	1.625	.875	.625	1.500	.750	5/8-18	3/8	3/32	3/16	57/64	.6250	650	5640	4840
1 3/4	CCNB-56-S	CCNB-56-SB	1.750	1.000	.750	1.750	.875	3/4-16	7/16	3/32	3/16	1-3/64	.7500	1250	7920	6385
1 7/8	CCNB-60-S	CCNB-60-SB	1.875	1.000	.750	1.750	.875	3/4-16	7/16	3/32	3/16	1-3/64	.7500	1250	7920	6385
2	CCNB-64-S	CCNB-64-SB	2.000	1.250	.875	2.000	1.000	7/8-14	1/2	1/8	3/16	1-13/64	.8750	1500	10570	8090
2 1/4	CCNB-72-S	CCNB-72-SB	2.250	1.250	.875	2.000	1.000	7/8-14	1/2	1/8	3/16	1-13/64	.8750	1500	10570	8090
2 1/2	CCNB-80-S	CCNB-80-SB	2.500	1.500	1.000	2.250	1.125	1-14	9/16	1/8	3/16	1-5/16	1.0000	2250	16450	11720
2 3/4	CCNB-88-S	CCNB-88-SB	2.750	1.500	1.000	2.250	1.125	1-14	9/16	1/8	3/16	1-5/16	1.0000	2250	16450	11720
3	CCNB-96-S	CCNB-96-SB	3.000	1.750	1.250	2.500	1.250	1 1/4-12	5/8	1/8	1/4	1-3/4	1.2500	3450	24910	15720
3 1/4	CCNB-104-S	CCNB-104-SB	3.250	1.750	1.250	2.500	1.250	1 1/4-12	5/8	1/8	1/4	1-3/4	1.2500	3450	24910	15720
3 1/2	CCNB-112-S	CCNB-112-SB	3.500	2.000	1.375	2.750	1.375	1 3/8-12	11/16	1/8	1/4	1-59/64	1.3750	4200	31625	22800
4	CCNB-128-S	CCNB-128-SB	4.000	2.250	1.500	3.500	1.500	1 1/2-12	3/4	1/8	1/4	2-9/32	1.5000	5000	44770	29985
5	~	CCNB-160-SB	5.000	2.750	2.000	5.062	2.562	2-12	7/8	3/16	1/4 N.P.T.	2 7/8	2.0000	5000	67950	46575
6	~	CCNB-192-SB	6.000	3.250	2.500	6.000	3.000	2 1/2-12	1	3/16	1/4 N.P.T.	3 3/8	2.5000	5000	80450	60000
7	~	CCNB-224-SB	7.000	3.750	3.000	7.687	4.125	3-12	1 1/4	3/16	1/4 N.P.T.	3 7/8	3.0000	5000	106930	75380
8	~	CCNB-256-SB	8.000	4.250	3.250	8.500	4.250	3 1/4-4	~	~	1/4 N.P.T.	4 3/4	3.2500	5000	144100	92200
9	~	CCNB-288-SB	9.000	4.750	3.750	9.500	4.750	3 1/2-4	~	~	1/4 N.P.T.	5 7/16	3.7500	5000	183430	113260
10	~	CCNB-320-SB	10.000	5.250	4.250	10.000	4.750	3 1/2-4	~	~	1/4 N.P.T.	5 59/64	4.2500	5000	215565	131545

\*Relubricate through head end only. Lubrication information – see page 15

⤷ For crown dimensions – see page 16

\*\*Clamping torque is based on dry threads. If threads are lubricated, use half of values shown

# Needle Bearing Cam Followers – Eccentric

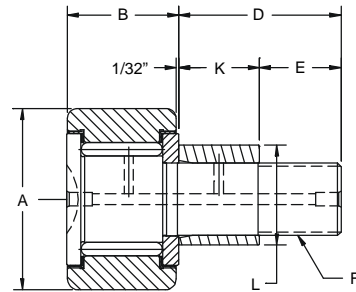

## Needle Bearing Cam Followers - Eccentric

Slotted														
Part Number			Roller		Bushing		Stud			Other Specs.				
			A	B	K	L	D	E	F					
Size	Unsealed Eccentric Stud	Sealed Eccentric Stud	Roller O.D. +.000 -.001	Roller Width +.000 -.005	Bushing Length +.000 -.010	Bushing Dia. + .001 -.001	Stud Length +.010 -.010	Min. Eff. Thread Length +.030 -.030	Thread Class 2A	Min. Boss Dia.	Recom. Bore +.0005 -.0000	**Recom. Torque Inch Pounds	Max. Static Capacity Pounds	Basic Dynamic Rating Pounds
1/2	CNBE-16	CNBE-16-S	.500	.375	.375	.250	.625	.250	10-32	19/64	.1900	15	790	680
5/8	CNBE-20	CNBE-20-S	.625	.4375	.437	.375	.750	.312	1/4-28	23/64	.2500	35	1215	995
11/16	CNBE-22	CNBE-22-S	.6875	.4375	.437	.375	.750	.312	1/4-28	23/64	.2500	35	1215	955
3/4	CNBE-24	CNBE-24-S	.750	.500	.500	.500	.875	.375	3/8-24	1/2	.3750	95	2065	1660
7/8	CNBE-28	CNBE-28-S	.875	.500	.500	.500	.875	.375	3/8-24	1/2	.3750	95	2065	1660
1	CNBE-32	CNBE-32-S	1.000	.625	.500	.625	1.000	.500	7/16-20	5/8	.4375	250	3060	2225
1 1/8	CNBE-36	CNBE-36-S	1.125	.625	.500	.625	1.000	.500	7/16-20	5/8	.4375	250	3060	2225
1 1/4	CNBE-40	CNBE-40-S	1.250	.750	.625	.687	1.250	.625	1/2-20	3/4	.5000	350	4250	3930
1 3/8	CNBE-44	CNBE-44-S	1.375	.750	.625	.687	1.250	.625	1/2-20	3/4	.5000	350	4250	3930
1 1/2	CNBE-48	CNBE-48-S	1.500	.875	.750	.875	1.500	.750	5/8-18	57/64	.6250	650	5640	4840
1 5/8	CNBE-52	CNBE-52-S	1.625	.875	.750	.875	1.500	.750	5/8-18	57/64	.6250	650	5640	4840
1 3/4	CNBE-56	CNBE-56-S	1.750	1.000	.875	1.000	1.750	.875	3/4-16	1-3/64	.7500	1250	7920	6385
1 7/8	CNBE-60	CNBE-60-S	1.875	1.000	.875	1.000	1.750	.875	3/4-16	1-3/64	.7500	1250	7920	6385
2	CNBE-64	CNBE-64-S	2.000	1.250	1.000	1.187	2.000	1.000	7/8-14	1-13/64	.8750	1500	10570	8090
2 1/4	CNBE-72	CNBE-72-S	2.250	1.250	1.000	1.187	2.000	1.000	7/8-14	1-13/64	.8750	1500	10570	8090
2 1/2	CNBE-80	CNBE-80-S	2.500	1.500	1.125	1.375	2.250	1.125	1-14	1-5/16	1.0000	2250	16450	11720
2 3/4	CNBE-88	CNBE-88-S	2.750	1.500	1.125	1.375	2.250	1.125	1-14	1-5/16	1.0000	2250	16450	11720
3	CNBE-96	CNBE-96-S	3.000	1.750	1.250	1.750	2.500	1.250	1 1/4-12	1-3/4	1.2500	3450	24910	15720
3 1/4	CNBE-104	CNBE-104-S	3.250	1.750	1.250	1.750	2.500	1.250	1 1/4-12	1-3/4	1.2500	3450	24910	15720
3 1/2	CNBE-112	CNBE-112-S	3.500	2.000	1.375	1.812	2.750	1.375	1 3/8-12	1-59/64	1.3750	4200	31625	22800
4	CNBE-128	CNBE-128-S	4.000	2.250	2.000	2.000	3.500	1.500	1 1/2-12	2-9/32	1.500	5000	44770	29985

○ For Eccentricity see chart page 16

\*\*Clamping torque is based on dry threads. If threads are lubricated, use half of values shown

# Needle Bearing Cam Followers - Eccentric

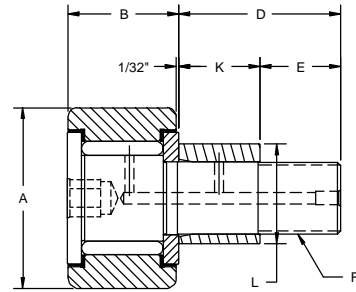

Needle Bearing Cam Followers - Eccentric														
Hexed														
Part Number			Roller		Bushing		Stud			Other Specs.				
			A	B	K	L	D	E	F					
Size	Unsealed Eccentric Stud	Sealed Eccentric Stud	Roller O.D +.000 -.001	Roller Width +.000 -.005	Bushing Length +.000 -.010	Bushing Dia. +.001 -.001	Stud Length +.010 -.010	Min. Eff. Thread Length +.030 -.030	Thread Class 2A	Min. Boss Dia.	Recom. Bore +.0005 -.0000	**Recom. Torque Inch Pounds	Max. Static Capacity Pounds	Basic Dynamic Rating Pounds
1/2	CNBE-16-B	CNBE-16-SB	.500	.375	.375	.250	.625	.250	10-32	19/64	.1900	15	790	680
5/8	CNBE-20-B	CNBE-20-SB	.625	.4375	.437	.375	.750	.312	1/4-28	23/64	.2500	35	1215	995
11/16	CNBE-22-B	CNBE-22-SB	.6875	.4375	.437	.375	.750	.312	1/4-28	23/64	.2500	35	1215	955
3/4	CNBE-24-B	CNBE-24-SB	.750	.500	.500	.500	.875	.375	3/8-24	1/2	.3750	95	2065	1660
7/8	CNBE-28-B	CNBE-28-SB	.875	.500	.500	.500	.875	.375	3/8-24	1/2	.3750	95	2065	1660
1	CNBE-32-B	CNBE-32-SB	1.000	.625	.500	.625	1.000	.500	7/16-20	5/8	.4375	250	3060	2225
1 1/8	CNBE-36-B	CNBE-36-SB	1.125	.625	.500	.625	1.000	.500	7/16-20	5/8	.4375	250	3060	2225
1 1/4	CNBE-40-B	CNBE-40-SB	1.250	.750	.625	.687	1.250	.625	1/2-20	3/4	.5000	350	4250	3930
1 3/8	CNBE-44-B	CNBE-44-SB	1.375	.750	.625	.687	1.250	.625	1/2-20	3/4	.5000	350	4250	3930
1 1/2	CNBE-48-B	CNBE-48-SB	1.500	.875	.750	.875	1.500	.750	5/8-18	57/64	.6250	650	5640	4840
1 5/8	CNBE-52-B	CNBE-52-SB	1.625	.875	.750	.875	1.500	.750	5/8-18	57/64	.6250	650	5640	4840
1 3/4	CNBE-56-B	CNBE-56-SB	1.750	1.000	.875	1.000	1.750	.875	3/4-16	1-3/64	.7500	1250	7920	6385
1 7/8	CNBE-60-B	CNBE-60-SB	1.875	1.000	.875	1.000	1.750	.875	3/4-16	1-3/64	.7500	1250	7920	6385
2	CNBE-64-B	CNBE-64-SB	2.000	1.250	1.000	1.187	2.000	1.000	7/8-14	1-13/64	.8750	1500	10570	8090
2 1/4	CNBE-72-B	CNBE-72-SB	2.250	1.250	1.000	1.187	2.000	1.000	7/8-14	1-13/64	.8750	1500	10570	8090
2 1/2	CNBE-80-B	CNBE-80-SB	2.500	1.500	1.125	1.375	2.250	1.125	1-14	1-5/16	1.0000	2250	16450	11720
2 3/4	CNBE-88-B	CNBE-88-SB	2.750	1.500	1.125	1.375	2.250	1.125	1-14	1-5/16	1.0000	2250	16450	11720
3	CNBE-96-B	CNBE-96-SB	3.000	1.750	1.250	1.750	2.500	1.250	1 1/4-12	1-3/4	1.2500	3450	24910	15720
3 1/4	CNBE-104-B	CNBE-104-SB	3.250	1.750	1.250	1.750	2.500	1.250	1 1/4-12	1-3/4	1.2500	3450	24910	15720
3 1/2	CNBE-112-B	CNBE-112-SB	3.500	2.000	1.375	1.812	2.750	1.375	1 3/8-12	1-59/64	1.3750	4200	31625	22800
4	CNBE-128-B	CNBE-128-SB	4.000	2.250	2.000	2.000	3.500	1.500	1 1/2-12	2-9/32	1.500	5000	44770	29985

○ For Eccentricity see chart page 16

\*\*Clamping torque is based on dry threads. If threads are lubricated, use half of values shown

# Needle Bearing Cam Followers – Eccentric, Crowned

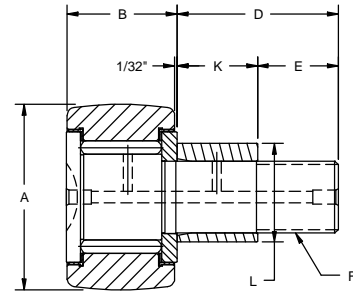

Needle Bearing Cam Followers – Eccentric, Crowned														
Sealed – Slotted & Hexed														
Part Number			Roller		Bushing		Stud			Other Specs.				
			A	B	K	L	D	E	F					
Size	Slotted Head With Crowned O.D.	Hexed Head With Crowned O.D.	Roller O.D. +.000 -.001	Roller Width +.000 -.005	Bushing Length +.000 -.010	Bushing Dia. +.001 -.001	Stud Length +.010 -.010	Min. Eff. Thread Length +.030 -.030	Thread Class 2A	Min. Boss Dia.	Recom. Bore +.0005 -.0000	**Recom. Torque Inch Pounds	Max. Static Capacity Pounds	Basic Dynamic Rating Pounds
1/2	CCNBE-16-S	CCNBE-16-SB	.500	.375	.375	.250	.625	.250	10-32	19/64	.1900	15	790	680
5/8	CCNBE-20-S	CCNBE-20-SB	.625	.4375	.437	.375	.750	.312	1/4-28	23/64	.2500	35	1215	995
11/16	CCNBE-22-S	CCNBE-22-SB	.6875	.4375	.437	.375	.750	.312	1/4-28	23/64	.2500	35	1215	955
3/4	CCNBE-24-S	CCNBE-24-SB	.750	.500	.500	.500	.875	.375	3/8-24	1/2	.3750	95	2065	1660
7/8	CCNBE-28-S	CCNBE-28-SB	.875	.500	.500	.500	.875	.375	3/8-24	1/2	.3750	95	2065	1660
1	CCNBE-32-S	CCNBE-32-SB	1.000	.625	.500	.625	1.000	.500	7/16-20	5/8	.4375	250	3060	2225
1 1/8	CCNBE-36-S	CCNBE-36-SB	1.125	.625	.500	.625	1.000	.500	7/16-20	5/8	.4375	250	3060	2225
1 1/4	CCNBE-40-S	CCNBE-40-SB	1.250	.750	.625	.687	1.250	.625	1/2-20	3/4	.5000	350	4250	3930
1 3/8	CCNBE-44-S	CCNBE-44-SB	1.375	.750	.625	.687	1.250	.625	1/2-20	3/4	.5000	350	4250	3930
1 1/2	CCNBE-48-S	CCNBE-48-SB	1.500	.875	.750	.875	1.500	.750	5/8-18	57/64	.6250	650	5640	4840
1 5/8	CCNBE-52-S	CCNBE-52-SB	1.625	.875	.750	.875	1.500	.750	5/8-18	57/64	.6250	650	5640	4840
1 3/4	CCNBE-56-S	CCNBE-56-SB	1.750	1.000	.875	1.000	1.750	.875	3/4-16	1-3/64	.7500	1250	7920	6385
1 7/8	CCNBE-60-S	CCNBE-60-SB	1.875	1.000	.875	1.000	1.750	.875	3/4-16	1-3/64	.7500	1250	7920	6385
2	CCNBE-64-S	CCNBE-64-SB	2.000	1.250	1.000	1.187	2.000	1.000	7/8-14	1-13/64	.8750	1500	10570	8090
2 1/4	CCNBE-72-S	CCNBE-72-SB	2.250	1.250	1.000	1.187	2.000	1.000	7/8-14	1-13/64	.8750	1500	10570	8090
2 1/2	CCNBE-80-S	CCNBE-80-SB	2.500	1.500	1.125	1.375	2.250	1.125	1-14	1-5/16	1.0000	2250	16450	11720
2 3/4	CCNBE-88-S	CCNBE-88-SB	2.750	1.500	1.125	1.375	2.250	1.125	1-14	1-5/16	1.0000	2250	16450	11720
3	CCNBE-96-S	CCNBE-96-SB	3.000	1.750	1.250	1.750	2.500	1.250	1 1/4-12	1-3/4	1.2500	3450	24910	15720
3 1/4	CCNBE-104-S	CCNBE-104-SB	3.250	1.750	1.250	1.750	2.500	1.250	1 1/4-12	1-3/4	1.2500	3450	24910	15720
3 1/2	CCNBE-112-S	CCNBE-112-SB	3.500	2.000	1.375	1.812	2.750	1.375	1 3/8-12	1-59/64	1.3750	4200	31625	22800
4	CCNBE-128-S	CCNBE-128-SB	4.000	2.250	2.000	2.000	3.500	1.500	1 1/2-12	2-9/32	1.5000	5000	44770	29985

○ For Eccentricity see chart page 16

⌋ For Crown dimensions – see page 16

\*\*Clamping torque is based on dry threads. If threads are lubricated, use half of values shown

# Needle Bearing Cam Followers - Heavy Duty

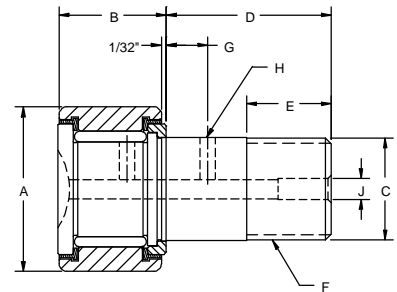

Needle Bearing Cam Followers – Heavy Duty																
Slotted																
Part Number			Roller		Stud				Lubrication			Other Specs.				
			A	B	C	D	E	F	G	H	J					
Size	Unsealed	Sealed	Roller O.D +.000 -.001	Roller Width +.000 -.005	Stud Dia. +.001 -.000	Stud Length +.010 -.010	Min. Eff. Thread Length +.030 -.030	Thread Class 2A	Oil Hole Center	Oil Hole Dia.	Lube Fitting Size	Min. Boss Dia.	Recom. Bore +.0005 -.0000	**Recom. Torque Inch Pounds	Max. Static Capacity Pounds	Basic Dynamic Rating Pounds
1/2	CNBH-16	CNBH-16-S	.500	.375	.250	.625	.250	1/4-28	~	~	*1/8	19/64	.1900	15	790	680
5/8	CNBH-20	CNBH-20-S	.625	.4375	.3125	.750	.312	5/16-24	~	~	*1/8	23/64	.2500	35	1215	995
11/16	CNBH-22	CNBH-22-S	.6875	.4375	.3125	.750	.312	5/16-24	~	~	*1/8	23/64	.2500	35	1215	955
3/4	CNBH-24	CNBH-24-S	.750	.500	.4375	.875	.375	7/16-20	1/4	3/32	3/16	1/2	.3750	95	2065	1660
7/8	CNBH-28	CNBH-28-S	.875	.500	.4375	.875	.375	7/16-20	1/4	3/32	3/16	1/2	.3750	95	2065	1660
1	CNBH-32	CNBH-32-S	1.000	.625	.625	1.000	.500	5/8-18	1/4	3/32	3/16	5/8	.4375	250	3060	2225
1 1/8	CNBH-36	CNBH-36-S	1.125	.625	.625	1.000	.500	5/8-18	1/4	3/32	3/16	5/8	.4375	250	3060	2225
1 1/4	CNBH-40	CNBH-40-S	1.250	.750	.750	1.250	.625	3/4-16	5/16	3/32	3/16	3/4	.5000	350	4250	3930
1 3/8	CNBH-44	CNBH-44-S	1.375	.750	.750	1.250	.625	3/4-16	5/16	3/32	3/16	3/4	.5000	350	4250	3930
1 1/2	CNBH-48	CNBH-48-S	1.500	.875	.875	1.500	.750	7/8-14	3/8	3/32	3/16	57/64	.6250	650	5640	4840
1 5/8	CNBH-52	CNBH-52-S	1.625	.875	.875	1.500	.750	7/8-14	3/8	3/32	3/16	57/64	.6250	650	5640	4840
1 3/4	CNBH-56	CNBH-56-S	1.750	1.000	1.000	1.750	.875	1-14	7/16	3/32	3/16	1-3/64	.7500	1250	7920	6385
1 7/8	CNBH-60	CNBH-60-S	1.875	1.000	1.000	1.750	.875	1-14	7/16	3/32	3/16	1-3/64	.7500	1250	7920	6385
2	CNBH-64	CNBH-64-S	2.000	1.250	1.125	2.000	1.000	1 1/8-12	1/2	1/8	3/16	1-13/64	.8750	1500	10570	8090
2 1/4	CNBH-72	CNBH-72-S	2.250	1.250	1.125	2.000	1.000	1 1/8-12	1/2	1/8	3/16	1-13/64	.8750	1500	10570	8090
2 1/2	CNBH-80	CNBH-80-S	2.500	1.500	1.250	2.250	1.125	1 1/4-12	9/16	1/8	3/16	1-5/16	1.0000	2250	16450	11720
2 3/4	CNBH-88	CNBH-88-S	2.750	1.500	1.250	2.250	1.125	1 1/4-12	9/16	1/8	3/16	1-5/16	1.0000	2250	16450	11720
3	CNBH-96	CNBH-96-S	3.000	1.750	1.500	2.500	1.250	1 1/2-12	5/8	1/8	1/4	1-3/4	1.2500	3450	24910	15720
3 1/4	CNBH-104	CNBH-104-S	3.250	1.750	1.500	2.500	1.250	1 1/2-12	5/8	1/8	1/4	1-3/4	1.2500	3450	24910	15720
3 1/2	CNBH-112	CNBH-112-S	3.500	2.000	1.750	2.750	1.375	1 3/4-12	11/16	1/8	1/4	1-59/64	1.3750	4200	31625	22800
4	CNBH-128	CNBH-128-S	4.000	2.250	2.000	3.500	1.500	2-12	3/4	1/8	1/4	2-9/32	1.500	5000	44770	29985

\*Relubricate through head end only. Lubrication information - see page 15

\*\*Clamping torque is based on dry threads. If threads are lubricated, use half of values shown.



# Needle Bearing Cam Followers - Heavy Duty

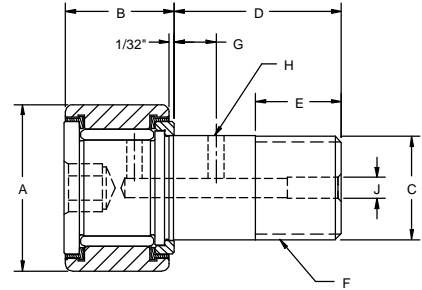

## Needle Bearing Cam Follower – Heavy Duty

Hexed																
Part Number			Roller		Stud				Lubrication			Other Specs.				
			A	B	C	D	E	F	G	H	J					
Size	Unsealed	Sealed	Roller O.D. +.000 -.001	Roller Width +.000 -.005	Stud Dia. +.001 -.000	Stud Length +.010 -.010	Min. Eff. Thread Length +.030 -.030	Thread Class 2A	Oil Hole Center	Oil Hole Dia.	Lube Fitting Size	Min. Boss Dia.	Recom. Bore +.0005 -.0000	**Recom. Torque Inch Pounds	Max. Static Capacity Pounds	Basic Dynamic Rating Pounds
1/2	CNBH-16-B	CNBH-16-SB	.500	.375	.250	.625	.250	1/4-28	~	~	*1/8	19/64	.1900	15	790	680
5/8	CNBH-20-B	CNBH-20-SB	.625	.4375	.3125	.750	.312	5/16-24	~	~	*1/8	23/64	.2500	35	1215	995
11/16	CNBH-22-B	CNBH-22-SB	.6875	.4375	.3125	.750	.312	5/16-24	~	~	*1/8	23/64	.2500	35	1215	955
3/4	CNBH-24-B	CNBH-24-SB	.750	.500	.4375	.875	.375	7/16-20	1/4	3/32	3/16	1/2	.3750	95	2065	1660
7/8	CNBH-28-B	CNBH-28-SB	.875	.500	.4375	.875	.375	7/16-20	1/4	3/32	3/16	1/2	.3750	95	2065	1660
1	CNBH-32-B	CNBH-32-SB	1.000	.625	.625	1.000	.500	5/8-18	1/4	3/32	3/16	5/8	.4375	250	3060	2225
1 1/8	CNBH-36-B	CNBH-36-SB	1.125	.625	.625	1.000	.500	5/8-18	1/4	3/32	3/16	5/8	.4375	250	3060	2225
1 1/4	CNBH-40-B	CNBH-40-SB	1.250	.750	.750	1.250	.625	3/4-16	5/16	3/32	3/16	3/4	.5000	350	4250	3930
1 3/8	CNBH-44-B	CNBH-44-SB	1.375	.750	.750	1.250	.625	3/4-16	5/16	3/32	3/16	3/4	.5000	350	4250	3930
1 1/2	CNBH-48-B	CNBH-48-SB	1.500	.875	.875	1.500	.750	7/8-14	3/8	3/32	3/16	5/7/64	.6250	650	5640	4840
1 5/8	CNBH-52-B	CNBH-52-SB	1.625	.875	.875	1.500	.750	7/8-14	3/8	3/32	3/16	5/7/64	.6250	650	5640	4840
1 3/4	CNBH-56-B	CNBH-56-SB	1.750	1.000	1.000	1.750	.875	1-14	7/16	3/32	3/16	1-3/64	.7500	1250	7920	6385
1 7/8	CNBH-60-B	CNBH-60-SB	1.875	1.000	1.000	1.750	.875	1-14	7/16	3/32	3/16	1-3/64	.7500	1250	7920	6385
2	CNBH-64-B	CNBH-64-SB	2.000	1.250	1.125	2.000	1.000	1 1/8-12	1/2	1/8	3/16	1-13/64	.8750	1500	10570	8090
2 1/4	CNBH-72-B	CNBH-72-SB	2.250	1.250	1.125	2.000	1.000	1 1/8-12	1/2	1/8	3/16	1-13/64	.8750	1500	10570	8090
2 1/2	CNBH-80-B	CNBH-80-SB	2.500	1.500	1.250	2.250	1.125	1 1/4-12	9/16	1/8	3/16	1-5/16	1.0000	2250	16450	11720
2 3/4	CNBH-88-B	CNBH-88-SB	2.750	1.500	1.250	2.250	1.125	1 1/4-12	9/16	1/8	3/16	1-5/16	1.0000	2250	16450	11720
3	CNBH-96-B	CNBH-96-SB	3.000	1.750	1.500	2.500	1.250	1 1/2-12	5/8	1/8	1/4	1-3/4	1.2500	3450	24910	15720
3 1/4	CNBH-104-B	CNBH-104-SB	3.250	1.750	1.500	2.500	1.250	1 1/2-12	5/8	1/8	1/4	1-3/4	1.2500	3450	24910	15720
3 1/2	CNBH-112-B	CNBH-112-SB	3.500	2.000	1.750	2.750	1.375	1 3/4-12	11/16	1/8	1/4	1-59/64	1.3750	4200	31625	22800
4	CNBH-128-B	CNBH-128-SB	4.000	2.250	2.000	3.500	1.500	2-12	3/4	1/8	1/4	2-9/32	1.500	5000	44770	29985
5	~	CNBH-160-SB	5.000	2.750	2.500	5.062	2.562	2 1/2-12	7/8	3/16	1/4 N.P.T.	2 7/8	2.0000	5000	67950	46575
6	~	CNBH-192-SB	6.000	3.250	3.000	6.000	3.000	3-12	1	3/16	1/4 N.P.T.	3 3/8	2.5000	5000	80450	60000
7	~	CNBH-224-SB	7.000	3.750	3.500	7.687	4.125	3 1/2-4 *	1 1/4	3/16	1/4 N.P.T.	3 7/8	3.0000	5000	106930	75380

\*Course Thread

\*Relubricate through head end only. Lubrication information - see page 15

\*\*Clamping torque is based on dry threads. If threads are lubricated, use half of values shown.

# Needle Bearing Cam Followers - Heavy Duty, Crowned

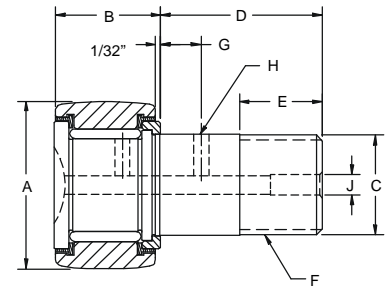

## Needle Bearing Cam Followers – Heavy Duty, Crowned

Sealed – Slotted & Hexed																
Part Number			Roller		Stud				Lubrication			Other Specs.				
Size	Slotted Head With Crowned O.D.	Hexed Head With Crowned O.D.	A	B	C	D	E	F	G	H	J	Min. Boss Dia.	Recom. Bore +.0005 -.0000	**Recm. Torque Inch Pounds	Max. Static Capacity Pounds	Basic Dynamic Rating Pounds
			Roller O.D +.000 -.001	Roller Width +.000 -.005	Stud Dia. +.001 -.000	Stud Length +.010 -.010	Min. Eff. Thread Length +.030 -.030	Thread Class 2A	Oil Hole Center	Oil Hole Dia.	Lube Fitting Size					
1/2	CCNBH-16-S	CCNBH-16-SB	.500	.375	.250	.625	.250	1/4-28	~	~	*1/8	19/64	.1900	15	790	680
5/8	CCNBH-20-S	CCNBH-20-SB	.625	.4375	.3125	.750	.312	5/16-24	~	~	*1/8	23/64	.2500	35	1215	995
11/16	CCNBH-22-S	CCNBH-22-SB	.6875	.4375	.3125	.750	.312	5/16-24	~	~	*1/8	23/64	.2500	35	1215	955
3/4	CCNBH-24-S	CCNBH-24-SB	.750	.500	.4375	.875	.375	7/16-20	1/4	3/32	3/16	1/2	.3750	95	2065	1660
7/8	CCNBH-28-S	CCNBH-28-SB	.875	.500	.4375	.875	.375	7/16-20	1/4	3/32	3/16	1/2	.3750	95	2065	1660
1	CCNBH-32-S	CCNBH-32-SB	1.000	.625	.625	1.000	.500	5/8-18	1/4	3/32	3/16	5/8	.4375	250	3060	2225
1 1/8	CCNBH-36-S	CCNBH-36-SB	1.125	.625	.625	1.000	.500	5/8-18	1/4	3/32	3/16	5/8	.4375	250	3060	2225
1 1/4	CCNBH-40-S	CCNBH-40-SB	1.250	.750	.750	1.250	.625	3/4-16	5/16	3/32	3/16	3/4	.5000	350	4250	3930
1 3/8	CCNBH-44-S	CCNBH-44-SB	1.375	.750	.750	1.250	.625	3/4-16	5/16	3/32	3/16	3/4	.5000	350	4250	3930
1 1/2	CCNBH-48-S	CCNBH-48-SB	1.500	.875	.875	1.500	.750	7/8-14	3/8	3/32	3/16	57/64	.6250	650	5640	4840
1 5/8	CCNBH-52-S	CCNBH-52-SB	1.625	.875	.875	1.500	.750	7/8-14	3/8	3/32	3/16	57/64	.6250	650	5640	4840
1 3/4	CCNBH-56-S	CCNBH-56-SB	1.750	1.000	1.000	1.750	.875	1-14	7/16	3/32	3/16	1-3/64	.7500	1250	7920	6385
1 7/8	CCNBH-60-S	CCNBH-60-SB	1.875	1.000	1.000	1.750	.875	1-14	7/16	3/32	3/16	1-3/64	.7500	1250	7920	6385
2	CCNBH-64-S	CCNBH-64-SB	2.000	1.250	1.125	2.000	1.000	1 1/8-12	1/2	1/8	3/16	1-13/64	.8750	1500	10570	8090
2 1/4	CCNBH-72-S	CCNBH-72-SB	2.250	1.250	1.125	2.000	1.000	1 1/8-12	1/2	1/8	3/16	1-13/64	.8750	1500	10570	8090
2 1/2	CCNBH-80-S	CCNBH-80-SB	2.500	1.500	1.250	2.250	1.125	1 1/4-12	9/16	1/8	3/16	1-5/16	1.0000	2250	16450	11720
2 3/4	CCNBH-88-S	CCNBH-88-SB	2.750	1.500	1.250	2.250	1.125	1 1/4-12	9/16	1/8	3/16	1-5/16	1.0000	2250	16450	11720
3	CCNBH-96-S	CCNBH-96-SB	3.000	1.750	1.500	2.500	1.250	1 1/2-12	5/8	1/8	1/4	1-3/4	1.2500	3450	24910	15720
3 1/4	CCNBH-104-S	CCNBH-104-SB	3.250	1.750	1.500	2.500	1.250	1 1/2-12	5/8	1/8	1/4	1-3/4	1.2500	3450	24910	15720
3 1/2	CCNBH-112-S	CCNBH-112-SB	3.500	2.000	1.750	2.750	1.375	1 3/4-12	11/16	1/8	1/4	1-59/64	1.3750	4200	31625	22800
4	CCNBH-128-S	CCNBH-128-SB	4.000	2.250	2.000	3.500	1.500	2-12	3/4	1/8	1/4	2-9/32	1.500	5000	44770	29985
5	~	CCNBH-160-SB	5.000	2.750	2.500	5.062	2.562	2 1/2-12	7/8	3/16	1/4 N.P.T.	2 7/8	2.0000	5000	67950	46575
6	~	CCNBH-192-SB	6.000	3.250	3.000	6.000	3.000	3-12	1	3/16	1/4 N.P.T.	3 3/8	2.5000	5000	80450	60000
7	~	CCNBH-224-SB	7.000	3.750	3.500	7.687	4.125	3 1/2-4 *	1 1/4	3/16	1/4 N.P.T.	3 7/8	3.0000	5000	106930	75380

\*Course Thread

\*Relubricate through head end only. Lubrication information - see page 15

) For Crown Dimensions – see chart on page 16

\*\*Clamping torque is based on dry threads. If threads are lubricated, use half of values shown.

# Needle Bearing Cam Yoke Rollers

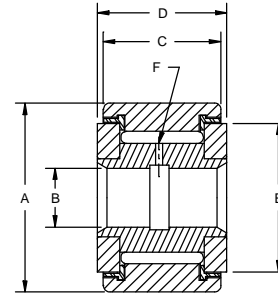

Needle Bearing Cam Yoke Rollers												
Unsealed and Sealed												
Part Number				Roller				Other Specs.				
Size	Unsealed	Sealed	Sealed With Crowned O.D.	A	B	C	D	E	F	Recom. Shaft Diameter +/- .0002	Max. Static Capacity Pounds	Basic Dynamic Rating Pounds
				Roller O.D. +.000 -0.001	Bore +.0002 -0.0004	Roller Width. +.000 -0.005	Total Width +.005 -0.010	Flange O.D. Ref.	Oil Hole Dia.			
3/4	YNB-24	YNB-24-S	CYNB-24-S	.750	.250	.500	.5625	5/8	3/32	.2497	4130	1660
7/8	YNB-28	YNB-28-S	CYNB-28-S	.875	.250	.500	.5625	5/8	3/32	.2497	4130	1660
1	YNB-32	YNB-32-S	CYNB-32-S	1.000	.3125	.625	.6875	23/32	3/32	.3122	6120	2225
1 1/8	YNB-36	YNB-36-S	CYNB-36-S	1.125	.3125	.625	.6875	23/32	3/32	.3122	6120	2225
1 1/4	YNB-40	YNB-40-S	CYNB-40-S	1.250	.375	.750	.8125	1	3/32	.3747	8500	3930
1 3/8	YNB-44	YNB-44-S	CYNB-44-S	1.375	.375	.750	.8125	1	3/32	.3747	8500	3930
1 1/2	YNB-48	YNB-48-S	CYNB-48-S	1.500	.4375	.875	.9375	1 1/8	3/32	.4372	11280	4840
1 5/8	YNB-52	YNB-52-S	CYNB-52-S	1.625	.4375	.875	.9375	1 1/8	3/32	.4372	11280	4840
1 3/4	YNB-56	YNB-56-S	CYNB-56-S	1.750	.500	1.000	1.0625	1 1/4	3/32	.4997	15840	6385
1 7/8	YNB-60	YNB-60-S	CYNB-60-S	1.875	.500	1.000	1.0625	1 1/4	3/32	.4997	15840	6385
2	YNB-64	YNB-64-S	CYNB-64-S	2.000	.625	1.250	1.3125	1 1/2	3/32	.6247	21140	8090
2 1/4	YNB-72	YNB-72-S	CYNB-72-S	2.250	.625	1.250	1.3125	1 1/2	3/32	.6247	21140	8090
2 1/2	YNB-80	YNB-80-S	CYNB-80-S	2.500	.750	1.000	1.5625	1 3/4	1/8	.7497	32900	11720
2 3/4	YNB-88	YNB-88-S	CYNB-88-S	2.750	.750	1.125	1.5625	1 3/4	1/8	.7497	32900	11720
3	YNB-96	YNB-96-S	CYNB-96-S	3.000	1.000	1.125	1.8125	~	1/8	.9996	49820	15720
3 1/4	YNB-104	YNB-104-S	CYNB-104-S	3.250	1.000	1.250	1.8125	~	1/8	.9996	49820	15720
3 1/2	YNB-112	YNB-112-S	CYNB-112-S	3.500	1.125	1.250	2.0625	~	1/8	1.1246	63250	22800
4	YNB-128	YNB-128-S	CYNB-128-S	4.000	1.250	2.250	2.3125	~	1/8	1.2496	89540	29985
5	~	YNB-160-S	CYNB-160-S	5.000	1.750	2.750	2.8750	~	3/16	1.7496	135900	46575
6	~	YNB-192-S	CYNB-192-S	6.000	2.250	3.250	3.3750	~	3/16	2.2496	160900	60000
7	~	YNB-224-S	CYNB-224-S	7.000	2.750	3.750	3.8750	~	3/16	2.7496	213860	75380
8	~	YNB-256-S	CYNB-256-S	8.000	3.255	4.250	4.5000	~	1/4	3.2553	288200	92200
9	~	YNB-288-S	CYNB-288-S	9.000	3.755	4.750	5.0000	~	5/16	3.7553	366850	113260
10	~	YNB-320-S	CYNB-320-S	10.000	4.255	5.250	5.5000	~	3/8	4.2553	431130	131545

For information on mounting cam rollers – see page 15  
 ) For crown dimensions – see chart page 16

# Needle Bearing Interchangeability Chart

Needle Bearing Cam Followers with Seals			
Type CNB			
Carter	McGill	RBC	Torr.
CNB-16-S	CF-1/2-S	S-16-L	CRS-8
CNB-20-S	CF-5/8-S	S-20-L	CRS-10
CNB-22-S	CF-11/16-S	S-22-L	~
CNB-24-S	CF-3/4-S	S-24-L	CRS-12
CNB-28-S	CF-7/8-S	S-28-L	CRS-14
CNB-32-S	CF-1-S	S-32-L	CRS-16
CNB-36-S	CF-1-1/8-S	S-36-L	CRS-18
CNB-40-S	CF-1-1/4-S	S-40-L	CRS-20
CNB-44-S	CF-1-3/8-S	S-44-L	CRS-22
CNB-48-S	CF-1-1/2-S	S-48-L	CRS-24
CNB-52-S	CF-1-5/8-S	S-52-L	CRS-26
CNB-56-S	CF-1-3/4-S	S-56-L	CRS-28
CNB-60-S	CF-1-7/8-S	S-60-L	CRS-30
CNB-64-S	CF-2-S	S-64-L	CRS-32
CNB-72-S	CF-2-1/4-S	S-72-L	CRS-36
CNB-80-S	CF-2-1/2-S	S-80-L	CRS-40
CNB-88-S	CF-2-3/4-S	S-88-L	CRS-44
CNB-96-S	CF-3-S	S-96-L	CRS-48
CNB-104-S	CF-3-1/4-S	S-104-L	CRS-52
CNB-112-S	CF-3-1/2-S	S-112-L	CRS-56
CNB-128-S	CF-4-S	S-128-L	CRS-64
CNB-160-S	CF-5-S	S-160-L	CRS-80
CNB-192-S	CF-6-S	S-192-L	CRS-96
CNB-224-S	CF-7-S	S-224-L	CRS-112
CNB-256-S	CF-8-S	S-256-L	CRS-128
CNB-228-S	CF-9-S	S-228-L	CRS-114
CNB-320-S	CF-10-S	S-320-L	CRS-160

Needle Bearing Cam Yoke Rollers and Seals			
Type YNB			
Carter	McGill	RBC	Torr.
YNB-24-S	CYR-3/4-S	Y-24-L	YCRS-12
YNB-28-S	CYR-7/8-S	Y-28-L	YCRS-14
YNB-32-S	CYR-1-S	Y-32-L	YCRS-16
YNB-36-S	CYR-1-1/8-S	Y-36-L	YCRS-18
YNB-40-S	CYR-1-1/4-S	Y-40-L	YCRS-20
YNB-44-S	CYR-1-3/8-S	Y-44-L	YCRS-22
YNB-48-S	CYR-1-1/2-S	Y-48-L	YCRS-24
YNB-52-S	CYR-1-5/8-S	Y-52-L	YCRS-26
YNB-56-S	CYR-1-3/4-S	Y-56-L	YCRS-28
YNB-60-S	CYR-1-7/8-S	Y-60-L	YCRS-30
YNB-64-S	CYR-2-S	Y-64-L	YCRS-32
YNB-72-S	CYR-2-1/4-S	Y-72-L	YCRS-36
YNB-80-S	CYR-2-1/2-S	Y-80-L	YCRS-40
YNB-88-S	CYR-2-3/4-S	Y-88-L	YCRS-44
YNB-96-S	CYR-3-S	Y-96-L	YCRS-48
YNB-104-S	CYR-3-1/4-S	Y-104-L	YCRS-52
YNB-112-S	CYR-3-1/2-S	Y-112-L	YCRS-56
YNB-128-S	CYR-4-S	Y-128-L	YCRS-64
YNB-160-S	CYR-5-S	Y-160-L	YCRS-80
YNB-192-S	CYR-6-S	Y-192-L	YCRS-96
YNB-224-S	CYR-7-S	Y-224-L	YCRS-112
YNB-256-S	CYR-8-S	Y-256-L	YCRS-128
YNB-228-S	CYR-9-S	Y-228-L	YCRS-
YNB-320-S	CYR-10-S	Y-320-L	YCRS-

## Comparative Type Number Changes For Added Features

For	Carter	McGill	RBC	Torrington
For Unsealed Construction	Omit <b>S</b> from suffix Type No. Example: CNB-16	Same as Carter Example: CF-1/2	Omit <b>L</b> from suffix Type No. Example S-16	Omit <b>S</b> from prefix Type No. Example: CR-8
Crowned O.D.s (Outer Diameters) With Seals	Add <b>C</b> in front of prefix Type No. Example: <u>CC</u> NB-16-S	Same as Carter Example: <u>CC</u> F-1/2-S	Same as Carter Example: <u>CS</u> -16-L	Same as Carter Example: <u>CC</u> RS-8
Hexagonal Socket (Instead of Slotted Mounting Hole) With Seals	Add <b>B</b> to suffix Type No. Example: CNB-16- <u>SB</u>	Same as Carter Example: CF-1/2- <u>SB</u>	Add <b>W</b> to suffix Type No. Example: S-16- <u>LW</u>	Add <b>B</b> to the end of prefix Type No. Example: CR <u>S</u> B-8
Eccentric Stud With Seals	Add <b>E</b> to the end of prefix Type No. Example: CNB <u>E</u> -16-S	Same as Carter Example: CF <u>E</u> -1/2-S	Add <b>X</b> to suffix Type No. Example: S-16- <u>LX</u>	Same as Carter Example: CR <u>E</u> -8
Heavy Stud Cam Followers	Add <b>H</b> to the end of prefix Type No. Example: CNB <u>H</u> -16-S	Same as Carter Example: CF <u>H</u> -1/2-S	Prefix is H Example: <u>H</u> -16-L	Same as Carter Example: CR <u>H</u> -8

**Note:** The Type Number may indicate several different extra features. For Example: Pertaining to Carter Bearings, an Eccentric Stud Bearing with a Crowned O.D. would be indicated by a C in front of the type designation for the Crowned O.D., and an E would be added for the Eccentric Stud, making the Type Number CCNBE.

# Needle Bearing Cam Followers- Standard Stainless Steel

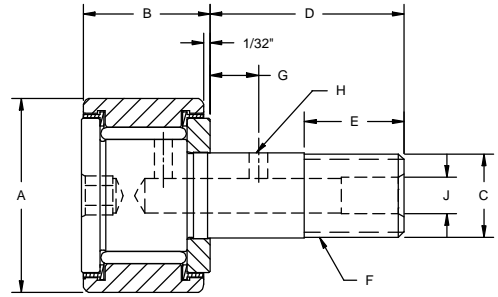

Needle Bearing Cam Follower - Standard Stainless Steel															
Hexed															
Part Number		Roller		Stud							Other Specs.				
		A	B	C	D	E	F	G	H	J					
Size	Sealed	Roller O.D +.000 -.001	Roller Width +.000 -.005	Stud Dia. +.001 -.000	Stud Length +.010 -.010	Min. Eff. Thread Length +.030 -.030	Thread Class 2A	Oil Hole Center	Oil Hole Dia.	Lube Fitting Size	Min. Boss Dia.	Recom. Bore +.0005 -.0000	**Recom. Torque Inch Pounds	Max. Static Capacity Pounds	Basic Dynamic Rating Pounds
1/2	SC-16-SB	.500	.375	.190	.625	.250	10-32	~	~	~	19/64	.1900	12	632	544
5/8	SC-20-SB	.625	.4375	.250	.750	.312	1/4-28	~	~	~	23/64	.2500	28	972	796
11/16	SC-22-SB	.6875	.4375	.250	.750	.312	1/4-28	~	~	~	23/64	.2500	28	972	796
3/4	SC-24-SB	.750	.500	.375	.875	.375	3/8-24	1/4	3/32	3/16	1/2	.3750	76	1652	1328
7/8	SC-28-SB	.875	.500	.375	.875	.375	3/8-24	1/4	3/32	3/16	1/2	.3750	76	1652	1328
1	SC-32-SB	1.000	.625	.4375	1.000	.500	7/16-20	1/4	3/32	3/16	5/8	.4375	200	2448	1780
1 1/8	SC-36-SB	1.125	.625	.4375	1.000	.500	7/16-20	1/4	3/32	3/16	5/8	.4375	200	2448	1780
1 1/4	SC-40-SB	1.250	.750	.500	1.250	.625	1/2-20	5/16	3/32	3/16	3/4	.5000	280	3400	3144
1 3/8	SC-44-SB	1.375	.750	.500	1.250	.625	1/2-20	5/16	3/32	3/16	3/4	.5000	280	3400	3144
1 1/2	SC-48-SB	1.500	.875	.625	1.500	.750	5/8-18	3/8	3/32	3/16	57/64	.6250	520	4572	3872
1 5/8	SC-52-SB	1.625	.875	.625	1.500	.750	5/8-18	3/8	3/32	3/16	57/64	.6250	520	4572	3872
1 3/4	SC-56-SB	1.750	1.000	.750	1.750	.875	3/4-16	7/16	3/32	3/16	1 3/64	.7500	1000	6336	5108
1 7/8	SC-60-SB	1.875	1.000	.750	1.750	.875	3/4-16	7/16	3/32	3/16	1 3/64	.7500	1000	6336	5108
2	SC-64-SB	2.000	1.250	.875	2.000	1.000	7/8-14	1/2	1/8	3/16	1 13/64	.8750	1200	8456	6472
2 1/4	SC-72-SB	2.250	1.250	.875	2.000	1.000	7/8-14	1/2	1/8	3/16	1 13/64	.8750	1200	8456	6472

○ Please call for availability on eccentric or crowned variations.

\*\*Clamping torque is based on dry threads. If threads are lubricated, use half of values shown

Available from stock  
 100% 440C Stainless Construction  
 Food Grade Grease Standard  
 Other lubricants are available.

# Cam Yoke Rollers - Standard Stainless Steel

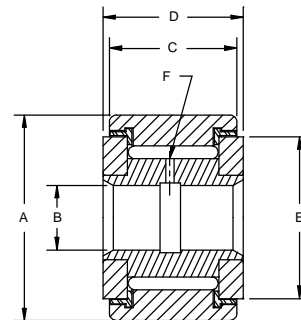

Cam Yoke Rollers – Standard Stainless Steel										
Sealed										
Part Number		Roller				Other Specs.				
		A	B	C	D	E	F			
Size	Sealed	Roller O.D +.000 -.001	Bore +.0002 -.0004	Roller Width. +.000 -.005	Total Width +.005 -.010	Flange O.D. Ref.	Oil Hole Dia.	Recom. Shaft Diameter +/- .0002	Max. Static Capacity Pounds	Basic Dynamic Rating Pounds
3/4	SY-24-S	.750	.250	.500	.5625	5/8	3/32	.2497	3304	1328
7/8	SY-28-S	.875	.250	.500	.5625	5/8	3/32	.2497	3304	1328
1	SY-32-S	1.000	.3125	.625	.6875	23/32	3/32	.3122	4896	1780
1 1/8	SY-36-S	1.125	.3125	.625	.6875	23/32	3/32	.3122	4896	1780
1 1/4	SY-40-S	1.250	.375	.750	.8125	1	3/32	.3747	6800	3144
1 3/8	SY-44-S	1.375	.375	.750	.8125	1	3/32	.3747	6800	3144
1 1/2	SY-48-S	1.500	.4375	.875	.9375	1 1/8	3/32	.4372	9024	3872
1 5/8	SY-52-S	1.625	.4375	.875	.9375	1 1/8	3/32	.4372	9024	3872
1 3/4	SY-56-S	1.750	.500	1.000	1.0625	1 1/4	3/32	.4997	12672	5180
1 7/8	SY-60-S	1.875	.500	1.000	1.0625	1 1/4	3/32	.4997	12672	5180
2	SY-64-S	2.000	.625	1.250	1.3125	1 1/2	3/32	.6247	12912	6472
2 1/4	SY-72-S	2.250	.625	1.250	1.3125	1 1/2	3/32	.6247	12912	6472

○ D Please call for availability on eccentric or crowned variations.

\*\*Clamping torque is based on dry threads. If threads are lubricated, use half of values shown

Available from stock  
 100% 440C Stainless Construction  
 Food Grade Grease Standard  
 Other lubricants are available.

### Lubrication Cam Followers and Cam Yoke Rollers

Both of these are packed with a petroleum based lithium grease with corrosion resistant additives. This lubricant is suited for most bearing applications within a temperature range of 0 °F to 250 °F. Relubrication of the Cam Yoke Rollers can be done through oil holes and the oil groove in the bore of the inner race. The mounting pin or shaft should be axially drilled and a radial hole drilled and matched with the hole in the race.

Provision for the lubrication of the Cam Followers should be provided where dimensions allow through either end of the stud or through a cross-drilled hole in the shank. The ends are counter-bored to accept drive type lubrication fittings (not furnished). Each Cam Follower is supplied with grease plugs and these should be press fit into unused holes in the end of the stud. When not used, the cross-hole is normally blocked when the Cam Follower is installed in the housing.

The following drive type fittings are recommended for lubrication of the CNB type Cam Followers.

CNB - 1/2" to 11/16" - 1/8" Alemite No. 3019 (Roller end only on these sizes.)

CNB - 3/4" to 2" - Alemite No.'s 1728-B, 1633, 1645-B, 3005, 3006, 3009, 3012-B

CNB - 2-1/4" to 2-3/4" - Alemite No.'s 1743 or 1743-B

---

### Mounting Cam Yoke Rollers

The recommended shaft diameters in the Selector Chart on page 8 provide for either a slip or press fit in the bearing bore for heavily loaded applications.

With moderate loads and a hardened shaft, a slip fit is sufficient. A slip or push fit and an unhardened shaft can be used in light load applications.

Endwise clamping of the Cam Yoke Rollers should be provided to prevent axial movement and displacement of the end washer. A flat housing shoulder that is square with the centerline of the bearing should be provided for holding the washer. This should be at least as large as the minimum clamping diameter shown in the chart to provide adequate washer support

# Dimension Chart

Crown O.D. Radius Dimensions		
Carter Part Size & No.	Crown O.D.	
1/2	CNB-16	7
5/8	CNB-20	8
11/16	CNB-22	8
3/4	CNB-24	10
7/8	CNB-28	10
1	CNB-32	12
1 1/8	CNB-36	12
1 1/4	CNB-40	14
1 3/8	CNB-44	14
1 1/2	CNB-48	20
1 5/8	CNB-52	20
1 3/4	CNB-56	20
1 7/8	CNB-60	20
2	CNB-64	24
2 1/4	CNB-72	24
2 1/2	CNB-80	30
2 3/4	CNB-88	30
3	CNB-96	30
3 1/4	CNB-104	30
3 1/2	CNB-112	30
4	CNB-128	30
5	CNB-160	48
6	CNB-192	56
7	CNB-224	60
8	CNB-256	40
9	CNB-288	40
10	CNB-320	40

Hex Wrench Sizes		
Carter Part Size & No.	Hex Wrench Size	
1/2	CNB-16	1/8
5/8	CNB-20	1/8
11/16	CNB-22	1/8
3/4	CNB-24	3/16
7/8	CNB-28	3/16
1	CNB-32	1/4
1 1/8	CNB-36	1/4
1 1/4	CNB-40	1/4
1 3/8	CNB-44	1/4
1 1/2	CNB-48	5/16
1 5/8	CNB-52	5/16
1 3/4	CNB-56	3/8
1 7/8	CNB-60	3/8
2	CNB-64	3/8
2 1/4	CNB-72	3/8
2 1/2	CNB-80	3/8
2 3/4	CNB-88	3/8
3	CNB-96	3/4
3 1/4	CNB-104	3/4
3 1/2	CNB-112	3/4
4	CNB-128	3/4
5	CNB-160	3/4
6	CNB-192	1
7	CNB-224	1 1/4
8	CNB-256	1 1/4
9	CNB-288	1 1/4
10	CNB-320	1 1/4

Eccentric Dimensions				
Carter Part Size & No.	Bushing Dia. +/- .001	Eccentricity	Recommended Housing Bore Dia. +/- .001	
1/2	CNBE-16	0.250	.010	0.253
5/8	CNBE-20	0.375	.015	0.378
11/16	CNBE-22	0.375	.015	0.378
3/4	CNBE-24	0.500	.015	0.503
7/8	CNBE-28	0.500	.015	0.503
1	CNBE-32	0.625	.030	0.628
1 1/8	CNBE-36	0.625	.030	0.628
1 1/4	CNBE-40	0.687	.030	0.690
1 3/8	CNBE-44	0.687	.030	0.690
1 1/2	CNBE-48	0.875	.030	0.878
1 5/8	CNBE-52	0.875	.030	0.878
1 3/4	CNBE-56	1.000	.030	1.003
1 7/8	CNBE-60	1.000	.030	1.003
2	CNBE-64	1.187	.030	1.190
2 1/4	CNBE-72	1.187	.030	1.190
2 1/2	CNBE-80	1.375	.030	1.378
2 3/4	CNBE-88	1.375	.030	1.378
3	CNBE-96	1.750	.060	1.753
3 1/4	CNBE-104	1.750	.060	1.753
3 1/2	CNBE-112	1.812	.060	1.815
4	CNBE-128	2.000	.060	2.003



# Neverlube Cam Followers

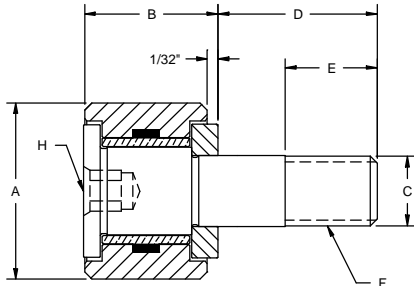
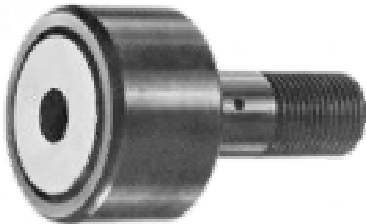

Neverlube Cam Followers										
Unsealed - Hexed										
Part Number			Roller		Stud			Other Specs.		
			A	B	C	D	E	F	H	
Size	Standard with Hex Socket	McGill Part Number	Roller O.D +.000 -.001	Roller Width +.000 -.005	Stud Dia. +.001 -.000	Stud Length +.010 -.010	Min. Eff. Thread Length +.030 -.030	Thread Class 2A	Hex Key Across Flats	*Load Factor
1/2	SFH-16-A	BCF-1/2-SB	.500	.375	.190	.625	.250	10-32	1/8	.070
5/8	SFH-20-A	BCF-5/8-SB	.625	.4375	.250	.750	.312	1/4-28	1/8	.097
11/16	SFH-22-A	BCF-11/16-SB	.6875	.4375	.250	.750	.312	1/4-28	1/8	.097
3/4	SFH-24-A	BCF-3/4-SB	.750	.500	.375	.875	.375	3/8-24	3/16	.164
7/8	SFH-28-A	BCF-7/8-SB	.875	.500	.375	.875	.375	3/8-24	3/16	.164
1	SFH-32-A	BCF-1-SB	1.000	.625	.4375	1.000	.500	7/16-20	1/4	.250
1 1/8	SFH-36-A	BCF-1 1/8-SB	1.125	.625	.4375	1.000	.500	7/16-20	1/4	.250
1 1/4	SFH-40-A	BCF-1 1/4-SB	1.250	.750	.500	1.250	.625	1/2-20	5/16	.391
1 3/8	SFH-44-A	BCF-1 3/8-SB	1.375	.750	.500	1.250	.625	1/2-20	5/16	.391
1 1/2	SFH-48-A	BCF-1 1/2-SB	1.500	.875	.625	1.500	.750	5/8-18	5/16	.544
1 5/8	SFH-52-A	BCF-1 5/8-SB	1.625	.875	.625	1.500	.750	5/8-18	5/16	.544
1 3/4	SFH-56-A	BCF-1 3/4-SB	1.750	1.000	.750	1.750	.875	3/4-16	3/8	.700
1 7/8	SFH-60-A	BCF-1 7/8-SB	1.875	1.000	.750	1.750	.875	3/4-16	3/8	.700
2	SFH-64-A	BCF-2-SB	2.000	1.125	.875	2.000	1.000	7/8-14	3/8	.984
2 1/4	SFH-72-A	BCF-2 1/4-SB	2.250	1.125	.875	2.000	1.000	7/8-14	3/8	.984
2 1/2	SFH-80-A	BCF-2 1/2-SB	2.500	1.500	1.000	2.250	1.125	1-14	3/8	1.56
2 3/4	SFH-88-A	BCF-2 3/4-SB	2.750	1.500	1.000	2.250	1.125	1-14	3/8	1.56
3	SFH-96-A	BCF-3-SB	3.000	1.750	1.250	2.500	1.250	1 1/4-12	1/2	2.00
3 1/4	SFH-104-A	BCF-3 1/4-SB	3.250	1.750	1.250	2.500	1.250	1 1/4-12	1/2	2.00
3 1/2	SFH-112-A	BCF-3 1/2-SB	3.500	2.000	1.375	2.750	1.375	1 3/8-12	1/2	2.70
4	SFH-128-A	BCF-4-SB	4.000	2.250	1.500	3.500	1.500	1 1/2-12	1/2	3.25

Neverlube Bearings are unsealed  
 For description and application - see pages 20 & 21  
 \*For load factor information - see page 21

# Neverlube Eccentric Cam Yoke Rollers - Eccentric

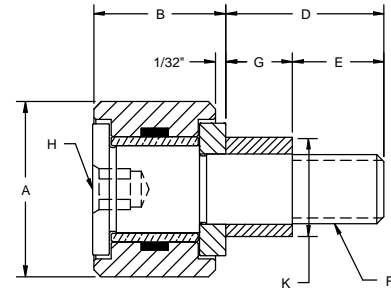

Neverlube Eccentric Cam Followers - Eccentric													
Unsealed - Hexed													
Part Number			Roller		Bushing		Stud			Other Specs.			
Size	Eccentric with Hex Socket	McGill Part Number	A	B	K	G	D	E	F	H		*Load Factor	
			Roller O.D. +.000 -.001	Roller Width +.000 -.005	Bushing Dia. +/- .001	Bushing Length +.000 -.010	Stud Length +.010 -.010	Min. Eff. Thread Length +.030 -.030	Thread Class 2A	Eccentric	Hex Key Across Flats		
5/8	SFWE-20-A	BCFE-5/8-SB	.625	.4375	.375	.437	.750	.312	1/4-28	.015	1/8	.097	
11/16	SFWE-22-A	BCFE-11/16-SB	.6875	.4375	.375	.437	.750	.312	1/4-28	.015	1/8	.097	
3/4	SFWE-24-A	BCFE-3/4-SB	.750	.500	.500	.500	.875	.375	3/8-24	.015	3/16	.164	
7/8	SFWE-28-A	BCFE-7/8-SB	.875	.500	.500	.500	.875	.375	3/8-24	.015	3/16	.164	
1	SFWE-32-A	BCFE-1-SB	1.000	.625	.625	.500	1.000	.500	7/16-20	.030	1/4	.250	
1 1/8	SFWE-36-A	BCFE-1 1/8-SB	1.125	.625	.625	.500	1.000	.500	7/16-20	.030	1/4	.250	
1 1/4	SFWE-40-A	BCFE-1 1/4-SB	1.250	.750	.687	.625	1.250	.625	1/2-20	.030	5/16	.391	
1 3/8	SFWE-44-A	BCFE-1 3/8-SB	1.375	.750	.687	.625	1.250	.625	1/2-20	.030	5/16	.391	
1 1/2	SFWE-48-A	BCFE-1 1/2-SB	1.500	.875	.875	.750	1.500	.750	5/8-18	.030	5/16	.544	
1 5/8	SFWE-52-A	BCFE-1 5/8-SB	1.625	.875	.875	.750	1.500	.750	5/8-18	.030	5/16	.544	
1 3/4	SFWE-56-A	BCFE-1 3/4-SB	1.750	1.000	1.000	.875	1.750	.875	3/4-16	.030	3/8	.700	
1 7/8	SFWE-60-A	BCFE-1 7/8-SB	1.875	1.000	1.000	.875	1.750	.875	3/4-16	.030	3/8	.700	
2	SFWE-64-A	BCFE-2-SB	2.000	1.125	1.187	1.000	2.000	1.000	7/8-14	.030	3/8	.984	
2 1/4	SFWE-72-A	BCFE-2 1/4-SB	2.250	1.125	1.187	1.000	2.000	1.000	7/8-14	.030	3/8	.984	
2 1/2	SFWE-80-A	BCFE-2 1/2-SB	2.500	1.500	1.375	1.125	2.250	1.125	1-14	.030	3/8	1.56	
2 3/4	SFWE-88-A	BCFE-2 3/4-SB	2.750	1.500	1.375	1.125	2.250	1.125	1-14	.030	3/8	1.56	
3	SFWE-96-A	BCFE-3-SB	3.000	1.750	1.750	1.250	2.500	1.250	1 1/4-12	.060	1/2	2.00	
3 1/4	SFWE-104-A	BCFE-3 1/4-SB	3.250	1.750	1.750	1.250	2.500	1.250	1 1/4-12	.060	1/2	2.00	
3 1/2	SFWE-112-A	BCFE-3 1/2-SB	3.500	2.000	1.812	1.375	2.750	1.375	1 3/8-12	.060	1/2	2.70	
4	SFWE-128-A	BCFE-4-SB	4.000	2.250	2.000	2.000	3.500	1.500	1 1/2-12	.060	1/2	3.25	

Neverlube Bearings are unsealed  
 For description and application - see pages 20 & 21  
 \*For load factor information - see page 21

# Neverlube Cam Yoke Rollers

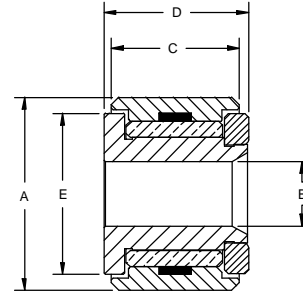

Neverlube Cam Yoke Rollers									
Standard - Unsealed									
Part Number			Roller				Other Specs.		
			A	B	C	D	E		
Size	Standard	McGill Part Number	Roller O.D +.000 -.001	Bore +.0002 -.0004	Roller Width +.000 -.005	Total Width +.005 -.010	Flange O.D. Ref.	Recom. Shaft Diameter +/- .0002	*Load Factor
3/4	NYR-24-A	BCYR-3/4-S	.750	.250	.500	.5625	5/8	.2497	.190
7/8	NYR-28-A	BCYR-7/8-S	.875	.250	.500	.5625	5/8	.2497	.190
1	NYR-32-A	BCYR-1-S	1.000	.3125	.625	.6875	11/16	.3122	.250
1 1/8	NYR-36-A	BCYR-1 1/8-S	1.125	.3125	.625	.6875	11/16	.3122	.250
1 1/4	NYR-40-A	BCYR-1 1/4-S	1.250	.375	.750	.8125	7/8	.3747	.390
1 3/8	NYR-44-A	BCYR-1 3/8-S	1.375	.375	.750	.8125	7/8	.3747	.390
1 1/2	NYR-48-A	BCYR-1 1/2-S	1.500	.4375	.875	.9375	1	.4372	.510
1 5/8	NYR-52-A	BCYR-1 5/8-S	1.625	.4375	.875	.9375	1	.4372	.510
1 3/4	NYR-56-A	BCYR-1 3/4-S	1.750	.500	1.000	1.0625	1 1/16	.4997	.650
1 7/8	NYR-60-A	BCYR-1 7/8-S	1.875	.500	1.000	1.0625	1 1/16	.4997	.650
2	NYR-64-A	BCYR-2-S	2.000	.625	1.125	1.3125	1 3/8	.6247	.928
2 1/4	NYR-72-A	BCYR-2 1/4-S	2.250	.625	1.250	1.3125	1 3/8	.6247	.928
2 1/2	NYR-80-A	BCYR-2 1/2-S	2.500	.750	1.000	1.5625	1 7/8	.7497	1.406
2 3/4	NYR-88-A	BCYR-2 3/4-S	2.750	.750	1.125	1.5625	1 7/8	.7497	2.00
3	NYR-96-A	BCYR-3-S	3.000	1.000*	1.125	1.8125	2	.9996	2.00
3 1/4	NYR-104-A	BCYR-3 1/4-S	3.250	1.000	1.250	1.8125	2	.9996	2.70
3 1/2	NYR-112-A	BCYR-3 1/2-S	3.500	1.125	1.250	2.0625	2	1.1246	2.70
4	NYR-128-A	BCYR-4-S	4.000	1.250	2.250	2.3125	2 3/16	1.2496	3.25

Neverlube Bearings are unsealed  
 For description and application - see pages 20 & 21  
 \*For load factor information - see page 21

# Consider all the advantages of CARTER NEVERLUBE CAM FOLLOWERS AND BEARINGS

## With Perma-FLO

### Lubrication for your bearing applications

#### This Advanced Design

of self-lubricating sleeve bearing has a heat-treated steel roller into which lubrication reservoirs are machined, as shown in the illustration below. These lubrication reservoirs are filled at the factory with specially developed lubrication mixtures. As the bearing operates, this lubrication penetrates through a porous sintered bronze bushing by capillary action providing continuous, dependable lubrication for the life of the bearing.

Lube Reservoir

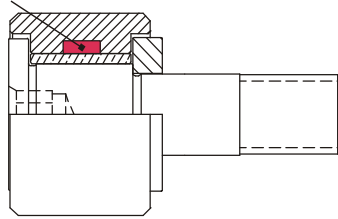

#### Continuous Self-Lubrication

Is an important advantage particularly in applications where lubricating the bearing is inconvenient, difficult, or even impossible. Other advantages arise where dirt, dust or other contaminants can seep in causing non self-lubing needle, roller, or ball bearings to “seize up”. You will see the advantages also in high humidity applications or where the equipment is subject to frequent “wash-downs”, as in food preparation or processing equipment. Because there are no internal moving elements, Neverlube Bearings can be trouble-free in these applications.

#### Lower Cost-

Because of their simplified design, Neverlube Bearings frequently cost *20% to 30% less* than comparably rated other types. The self-lubricating feature also helps reduce maintenance costs and assures adequate lubrication at all times, greatly reducing the possibility of bearing failure and service costs.

#### Clean Lubrication-

Another important advantage of Carter Neverlube Bearings! The Neverlube feature not only eliminates the problem of lubrication leakage due to overlubrication, but the plastic lube mixture reverts to its original consistency when the bearing is not in use, preventing any leakage from this source. This “clean” lubrication is an important advantage, particularly in the application of food preparation or processing equipment.

#### Interchangeability-

Neverlube Bearings are interchangeable with many standard types of Needle Roller Bearings dimensionally and otherwise (see application data on page 15). You can frequently have the self-lubricating features of Neverlube Bearings and also save cost on many of your present bearing applications.

#### Temperature Range-

The Standard Neverlube Lubricant has an ambient temperature range of 30 ° F to 150 ° F. This is normally supplied and is suitable for most applications. In addition, the following special lubricants can be supplied on request for other applications:

- Synthetic High Temperature Lubricant-  
Range -40 ° F to +330 ° F
- Synthetic Low Temperature Lubricant-  
For applications requiring low temperature specifications down to -80 ° F.

# Neverlube Application Data

## Applications

Neverlube Bearings are particularly well suited to applications with light to moderate loads operating at medium to higher speeds. However, they have been used successfully in many other applications. Frequently, the best means of determining this is simply to try a sample with your application.

They are not normally recommended, however, with applications encompassing the following:

- Extra heavy loading at static or low speeds
- Heavy shock loads in conjunction with slow speeds or vibrating conditions
- Constant high ambient temperatures in excess of 200 ° F unless supplied with the special high temperature lube.

Frequently the best way is to compute the load and see if it conforms to your application, and then simply try a sample and see how it performs. Some difficult conditions are so infrequent; they seldom pose a problem.

Some of the typical applications of Neverlube Bearings are:

**Food Processing Machinery**, which is often subject to frequent “wash-downs”. The lack of moving parts and the “clean” self-lubricating features of the Neverlube Bearings are particularly valuable.

**Farm and Construction Machinery**, which are often subject to a great deal of dust and grime. Standard types often “seize” in this instance.

**Machine Tools and Metalworking Machinery**, where the bearings are often inaccessible and subject to chips, coolants and grime. Standard types often “seize” in this instance.

**Packing Machinery**, as with Food Processing Machinery, can take advantage of the clean, self-lubricating features of the Neverlube Bearing, and is particularly desirable in many of these applications.

**And Many More...**

## Load Data For Cam Followers & Cam Yoke Rollers

Because of their special design, Neverlube Cam Followers and Cam Yoke Rollers have a PV factor of 80,000 on which the following is based. To determine the safe load capacity for a specific load and RPM, use the load factor shown on the catalog data page in conjunction with the following table:

RPM	Unit Load PSI
Slow and intermittent	4,000 Lbs.
150 to 300	2,000 Lbs.
300 to 600	600 Lbs.
600 to 900	400 Lbs.
900 to 1200	300 Lbs.
For higher RPM's consult the factory	

**Example:**

SFH-40-A Cam Follower at 800 RPM =  
.391 (Load Factor) X 400 = 156.4 Lbs. Capacity

## SHOCK FACTORS

The load ratings given are based generally on uniform or steady loading. If the loading is of shock nature, the following factors should be divided into the bearing capacity:

Type of load	Factor
Uniform and Constant	1.0
Light Shock	1.5
Moderate Shock	2.0
Heavy Shock	3.0

## INSTALLATION

The outside diameter of Neverlube Bearings is precision ground between centers from the finished bore. The maximum concentricity T.I.R. bore to O.D. is less than .001”. Because of the steel outer construction, no reworking of the bore is necessary after the bearing is pressed into the housing assembly. This is also an important advantage when replacing bearings on equipment in use.

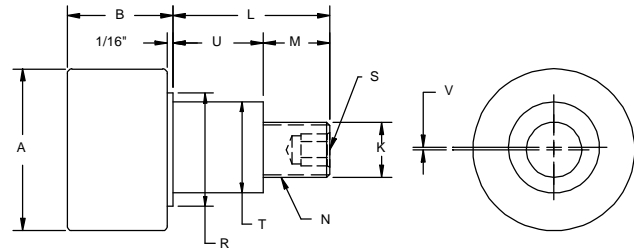
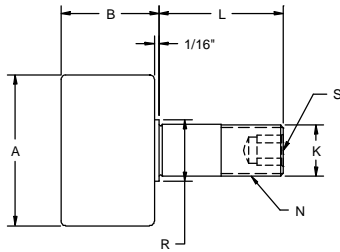

Plain Hi-Roller														
Part Number				Roller		Stud					Other Specs.			
				A	B	K	L	M	N	R	S			
Size	Sealed with Hex Socket	McGill Part Number	Osborn Part Number	Roller O.D +.000 -.001	Roller Width +.000 -.005	Stud Dia. +.001 -.000	Stud Length +.010 -.010	Min. Eff. Thread Length +.030 -.030	Thread Class 2A	Shlder. Dia.	Hex Socket	Basic Dynamic Rating	Dynamic Thrust Load* Rating (Lbs.)	Max. Static Capacity (Lbs.)
1 1/2	PHR-1 1/2	PCF-1 1/2	PLR-1 1/2	1.500	1.188	.625	1.500	.750	5/8-18	.750	5/16	2750	1700	1100
1 3/4	PHR-1 3/4	PCF-1 3/4	PLR-1 3/4	1.750	1.188	.750	1.750	.875	3/4-16	1.000	5/16	2750	1700	1100
2	PHR-2	PCF-2	PLR-2	2.000	1.688	.875	2.000	1.125	7/8-14	1.000	5/16	3820	2380	1620
2 1/4	PHR-2 1/4	PCF-2 1/4	PLR-2 1/4	2.250	1.688	.875	2.000	1.125	7/8-14	1.000	5/16	3820	2380	1620
2 1/2	PHR-2 1/2	PCF-2 1/2	PLR-2 1/2	2.500	1.688	1.000	2.250	1.500	1-14	1.250	1/2	5180	3185	2270
2 3/4	PHR-2 3/4	PCF-2 3/4	PLR-2 3/4	2.750	1.688	1.000	2.250	1.500	1-14	1.250	1/2	5180	3185	2270
3	PHR-3	PCF-3	PLR-3	3.000	2.000	1.250	2.500	1.750	1 1/4-12	1.750	1/2	14300	5790	20000
3 1/4	PHR-3 1/4	PCF-3 1/4	PLR-3 1/4	3.250	2.000	1.250	2.500	1.750	1 1/4-12	1.750	1/2	14300	5790	20000
3 1/2	PHR-3 1/2	PCF-3 1/2	PLR-3 1/2	3.500	2.000	1.250	2.750	1.750	1 1/4-12	1.750	1/2	14300	5790	20000
4	PHR-4	PCF-4	PLR-4	4.000	2.000	1.250	2.750	1.750	1 1/4-12	1.750	1/2	14300	5790	20000
4 1/2	PHR-4 1/2	PCF-4 1/2	PLR-4 1/2	4.500	2.000	1.250	2.750	1.750	1 1/4-12	1.750	1/2	14300	5790	20000
5	PHR-5	PCF-5	PLR-5	5.000	3.000	2.000	4.500	2.500	2-12	2.500	5/8	35800	14200	56400
6	PHR-6	PCF-6	PLR-6	6.000	3.000	2.500	5.500	3.250	2 1/2-12	3.250	5/8	35800	14200	56400
7	PHR-7	PCF-7	PLR-7	7.000	3.000	2.500	5.500	3.250	2 1/2-12	3.250	5/8	35800	14200	56400
8	PHR-8	PCF-8	PLR-8	8.000	3.000	2.500	5.500	3.250	2 1/2-12	3.250	5/8	35800	14200	56400
10	PHR-10	~	PLR-10	10.000	3.000	2.500	5.500	3.250	2 1/2-12	3.250	5/8	35800	14200	56400

Plain Hi-Roller - Eccentric														
Part Number			Roller		Stud					Other Specs.				
			A	B	K	L	M	N	R	S	T	U	V	
Size	Sealed with Hex Socket	Osborn Part Number	Roller O.D +.000 -.001	Roller Width +.000 -.005	Stud Dia. +.001 -.000	Stud Length +.010 -.010	Min. Eff. Thread Length +.030 -.030	Thread Class 2A	Shlder. Dia.	Hex Socket	Ecc. Dia. +.001 -.001	Ecc. Length +.000 -.010	Eccent.	
1 1/2	PHRE-1 1/2	PLRE-1 1/2	1.500	1.188	.625	1.500	.750	5/8-18	.750	5/16	.875	.730	.030	
1 3/4	PHRE-1 3/4	PLRE-1 3/4	1.750	1.188	.750	1.750	.875	3/4-16	1.000	5/16	1.000	.855	.030	
2	PHRE-2	PLRE-2	2.000	1.688	.875	2.000	1.125	7/8-14	1.000	5/16	1.187	.980	.030	
2 1/4	PHRE-2 1/4	PLRE-2 1/4	2.250	1.688	.875	2.000	1.125	7/8-14	1.000	5/16	1.187	.980	.030	
2 1/2	PHRE-2 1/2	PLRE-2 1/2	2.500	1.688	1.000	2.250	1.500	1-14	1.250	1/2	1.375	1.105	.030	
2 3/4	PHRE-2 3/4	PLRE-2 3/4	2.750	1.688	1.000	2.250	1.500	1-14	1.250	1/2	1.375	1.105	.030	
3	PHRE-3	PLRE-3	3.000	2.000	1.250	2.500	1.750	1 1/4-12	1.750	1/2	1.750	1.230	.060	
3 1/4	PHRE-3 1/4	PLRE-3 1/4	3.250	2.000	1.250	2.500	1.750	1 1/4-12	1.750	1/2	1.750	1.230	.060	
3 1/2	PHRE-3 1/2	PLRE-3 1/2	3.500	2.000	1.250	2.750	1.750	1 1/4-12	1.750	1/2	1.812	1.355	.060	
4	PHRE-4	PLRE-4	4.000	2.000	1.250	2.750	1.750	1 1/4-12	1.750	1/2	1.812	1.355	.060	
4 1/2	PHRE-4 1/2	PLRE-4 1/2	4.500	2.000	1.250	2.750	1.750	1 1/4-12	1.750	1/2	2.625	2.125	.060	
5	PHRE-5	PLRE-5	5.000	3.000	2.000	4.500	2.500	2-12	2.500	5/8	2.625	2.125	.060	
6	PHRE-6	PLRE-6	6.000	3.000	2.500	5.500	3.250	2 1/2-12	3.250	5/8	3.125	2.875	.060	

© For Load Ratings – see chart at top of page. Load Ratings based on 500 hours L10 life @ 33 1/3 RP

# Flanged Hi-Roller

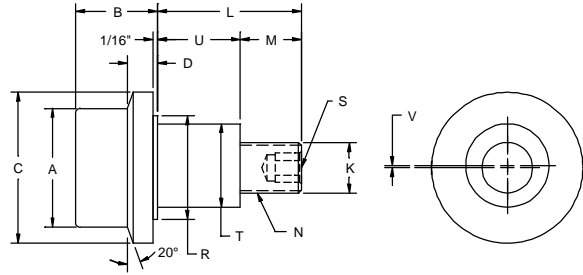
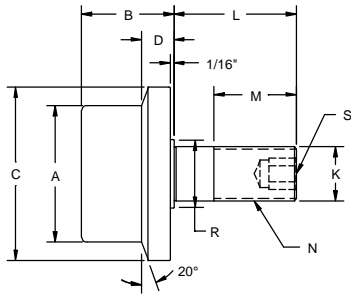

Flanged Hi-Roller																
Part Number				Roller				Stud					Other Specs.			
				A	B	C	D	K	L	M	N	R	S			
Size	Sealed with Hex Socket	McGill Part Number	Osborn Part Number	Roller O.D.	Roller Width +.000 -.005	Flange Dia.	Flange Width	Stud Dia. +.001 -.000	Stud Length +.010 -.010	Min. Eff. Thread Length +.030 -.030	Thread Class 2A	Shlder. Dia.	Hex Socket	Basic Dynamic Rating	Dynamic Thrust Load* Rating (Lbs)	Max. Static Capacity (Lbs)
1 1/2	FHR-1 1/2	FCF-1 1/2	FLR-1 1/2	1.500	1.188	2.188	.344	.625	1.500	.750	5/8-18	.750	5/16	2750	1700	1100
1 3/4	FHR-1 3/4	FCF-1 3/4	FLR-1 3/4	1.750	1.188	2.438	.344	.750	1.750	.875	3/4-16	1.000	5/16	2750	1700	1100
2	FHR-2	FCF-2	FLR-2	2.000	1.688	2.688	.594	.875	2.000	1.125	7/8-14	1.000	5/16	3820	2380	1620
2 1/4	FHR-2 1/4	FCF-2 1/4	FLR-2 1/4	2.250	1.688	2.938	.594	.875	2.000	1.125	7/8-14	1.000	5/16	3820	2380	1620
2 1/2	FHR-2 1/2	FCF-2 1/2	FLR-2 1/2	2.500	1.688	3.188	.594	1.000	2.250	1.500	1-14	1.250	1/2	5180	3185	2270
2 3/4	FHR-2 3/4	FCF-2 3/4	FLR-2 3/4	2.750	1.688	3.438	.594	1.000	2.250	1.500	1-14	1.250	1/2	5180	3185	2270
3	FHR-3	FCF-3	FLR-3	3.000	2.000	3.938	.594	1.250	2.500	1.750	1 1/4-12	1.750	1/2	14300	5790	20000
3 1/4	FHR-3 1/4	FCF-3 1/4	FLR-3 1/4	3.250	2.000	4.188	.594	1.250	2.500	1.750	1 1/4-12	1.750	1/2	14300	5790	20000
3 1/2	FHR-3 1/2	FCF-3 1/2	FLR-3 1/2	3.500	2.000	4.438	.594	1.250	2.750	1.750	1 1/4-12	1.750	1/2	14300	5790	20000
4	FHR-4	FCF-4	FLR-4	4.000	2.000	4.938	.594	1.250	2.750	1.750	1 1/4-12	1.750	1/2	14300	5790	20000
4 1/2	FHR-4 1/2	FCF-4 1/2	FLR-4 1/2	4.500	2.000	5.438	.594	1.250	2.750	1.750	1 1/4-12	1.750	1/2	14300	5790	20000
5	FHR-5	FCF-5	FLR-5	5.000	3.000	5.938	.719	2.000	4.500	2.500	2-12	2.500	5/8	35800	14200	56400
6	FHR-6	FCF-6	FLR-6	6.000	3.000	6.938	.719	2.500	5.500	3.250	2 1/2-12	3.250	5/8	35800	14200	56400
7	FHR-7	FCF-7	FLR-7	7.000	3.000	7.938	.719	2.500	5.500	3.250	2 1/2-12	3.250	5/8	35800	14200	56400
8	FHR-8	FCF-8	FLR-8	8.000	3.000	8.938	.719	2.500	5.500	3.250	2 1/2-12	3.250	5/8	35800	14200	56400

Flanged Hi-Roller - Eccentric															
Part Number			Roller				Stud					Other Specs.			
			A	B	C	D	K	L	M	N	R	S	T	U	V
Size	Sealed with Hex Socket	Osborn Part Number	Roller O.D.	Roller Width +.000 -.005	Flange Dia.	Flange Width	Stud Dia. +.001 -.000	Stud Length +.010 -.010	Min. Eff. Thread Length +.030 -.030	Thread Class 2A	Shlder. Dia.	Hex Socket	Ecc. Dia. +.001 -.001	Ecc. Length +.000 -.010	Eccent.
1 1/2	FHRE-1 1/2	FLRE-1 1/2	1.500	1.188	2.188	.344	.625	1.500	.750	5/8-18	.750	5/16	.875	.730	.030
1 3/4	FHRE-1 3/4	FLRE-1 3/4	1.750	1.188	2.438	.344	.750	1.750	.875	3/4-16	1.000	5/16	1.000	.855	.030
2	FHRE-2	FLRE-2	2.000	1.688	2.688	.594	.875	2.000	1.125	7/8-14	1.000	5/16	1.187	.980	.030
2 1/4	FHRE-2 1/4	FLRE-2 1/4	2.250	1.688	2.938	.594	.875	2.000	1.125	7/8-14	1.000	5/16	1.187	.980	.030
2 1/2	FHRE-2 1/2	FLRE-2 1/2	2.500	1.688	3.188	.594	1.000	2.250	1.500	1-14	1.250	1/2	1.375	1.105	.030
2 3/4	FHRE-2 3/4	FLRE-2 3/4	2.750	1.688	3.438	.594	1.000	2.250	1.500	1-14	1.250	1/2	1.375	1.105	.030
3	FHRE-3	FLRE-3	3.000	2.000	3.938	.594	1.250	2.500	1.750	1 1/4-12	1.750	1/2	1.750	1.230	.060
3 1/4	FHRE-3 1/4	FLRE-3 1/4	3.250	2.000	4.188	.594	1.250	2.500	1.750	1 1/4-12	1.750	1/2	1.750	1.230	.060
3 1/2	FHRE-3 1/2	FLRE-3 1/2	3.500	2.000	4.438	.594	1.250	2.750	1.750	1 1/4-12	1.750	1/2	1.812	1.355	.060
4	FHRE-4	FLRE-4	4.000	2.000	4.938	.594	1.250	2.750	1.750	1 1/4-12	1.750	1/2	1.812	1.355	.060

© For Load Ratings – see chart at top of page. Load Ratings based on 500 hours L10 life @ 33 1/3 RPM

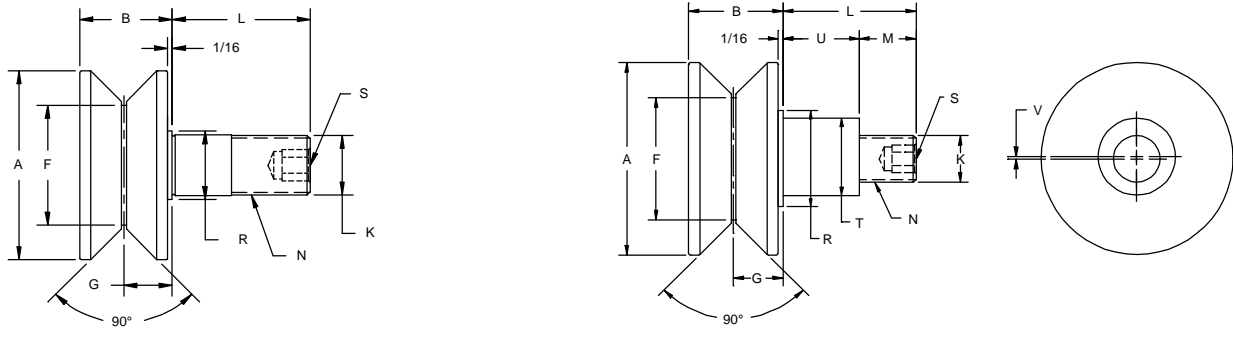

V-Groove Hi-Roller																	
Part Number				Roller				Stud						Other Specs.			
				A	B	F	G	K	L	M	N	R	S				
Size	Sealed with Hex Socket	McGill Part Number	Osborn Part Number	Roller O.D.	Roller Width +.000 -.005	Point Dia.	Groove Loc.	Stud Dia. +.001 -.000	Stud Length +.010 -.010	Min. Eff. Thread Length +.030 -.030	Thread Class 2A	Shoulder Dia.	Hex Socket	Basic Dynamic Rating	Dynamic Thrust Load* Rating (Lbs)	Max. Static Capacity (Lbs)	
2 1/2	VHR-2 1/2	~	VLR-2 1/2	2.500	1.313	1.500	.688	.750	1.750	.875	3/4-16	1.000	5/16	2750	1700	1100	
3 1/2	VHR-3 1/2	VCF-3 1/2	VLR-3 1/2	3.500	1.688	2.250	.875	.875	2.000	1.125	7/8-14	1.000	5/16	5180	3185	2270	
4 1/2	VHR-4 1/2	VCF-4 1/2	VLR-4 1/2	4.500	2.000	3.000	1.000	1.250	2.500	1.750	1 1/4-12	1.750	1/2	14300	5790	20000	
5 1/2	VHR-5 1/2	VCF-5 1/2	VLR-5 1/2	5.000	2.000	4.000	1.000	1.250	2.750	2.500	1 1/4-12	1.750	1/2	14300	5790	20000	
6 1/2	VHR-6 1/2	VCF-6 1/2	VLR-6 1/2	6.000	3.000	5.000	1.500	2.000	4.500	3.250	2-12	3.250	5/8	35800	12800	56400	
7 1/2	VHR-7 1/2	VCF-7 1/2	VLR-7 1/2	7.000	3.000	6.000	1.500	2.500	5.500	3.250	2 1/2-12	3.250	5/8	35800	12800	56400	
8 1/2	VHR-8 1/2	VCF-8 1/2	VLR-8 1/2	8.000	3.000	7.000	1.500	2.500	5.500	3.250	2 1/2-12	3.250	5/8	35800	12800	56400	

V-Groove Hi-Roller - Eccentric																	
Part Number			Roller				Stud						Other Specs.				
			A	B	F	G	K	L	M	N	R	S	T	U	V		
Size	Sealed with Hex Socket	Osborn Part Number	Roller O.D.	Roller Width +.000 -.005	Point Dia.	Groove Loc.	Stud Dia. +.001 -.000	Stud Length +.010 -.010	Min. Eff. Thread Length +.030 -.030	Thread Class 2A	Shoulder Dia.	Hex Socket	Ecc. Dia. +.001 -.001	Ecc. Length +.000 -.010	Eccent.		
2 1/2	VHRE-2 1/2	VLRE-2 1/2	2.500	1.313	1.500	.688	.750	1.750	.875	3/4-16	1.000	5/16	1.000	.855	.030		
3 1/2	VHRE-3 1/2	VLRE-3 1/2	3.500	1.688	2.250	.875	.875	2.000	1.125	7/8-14	1.000	5/16	1.187	.980	.030		
4 1/2	VHRE-4 1/2	VLRE-4 1/2	4.500	2.000	3.000	1.000	1.250	2.500	1.750	1 1/4-12	1.750	1/2	1.750	1.230	.060		

© For Load Ratings – see chart at top of page. Load Ratings are based on 500 hours L10 life @ 33 1/3 RPM