

FAG Split Plummer Block Housings of Series SNV

for shaft diameters of 20 to 160 mm and $\frac{3}{4}$ to $5\frac{1}{2}$ inches

FAG

Rolling Bearings

FAG OEM und Handel AG

Publ. No. WL 90 118/3 EA

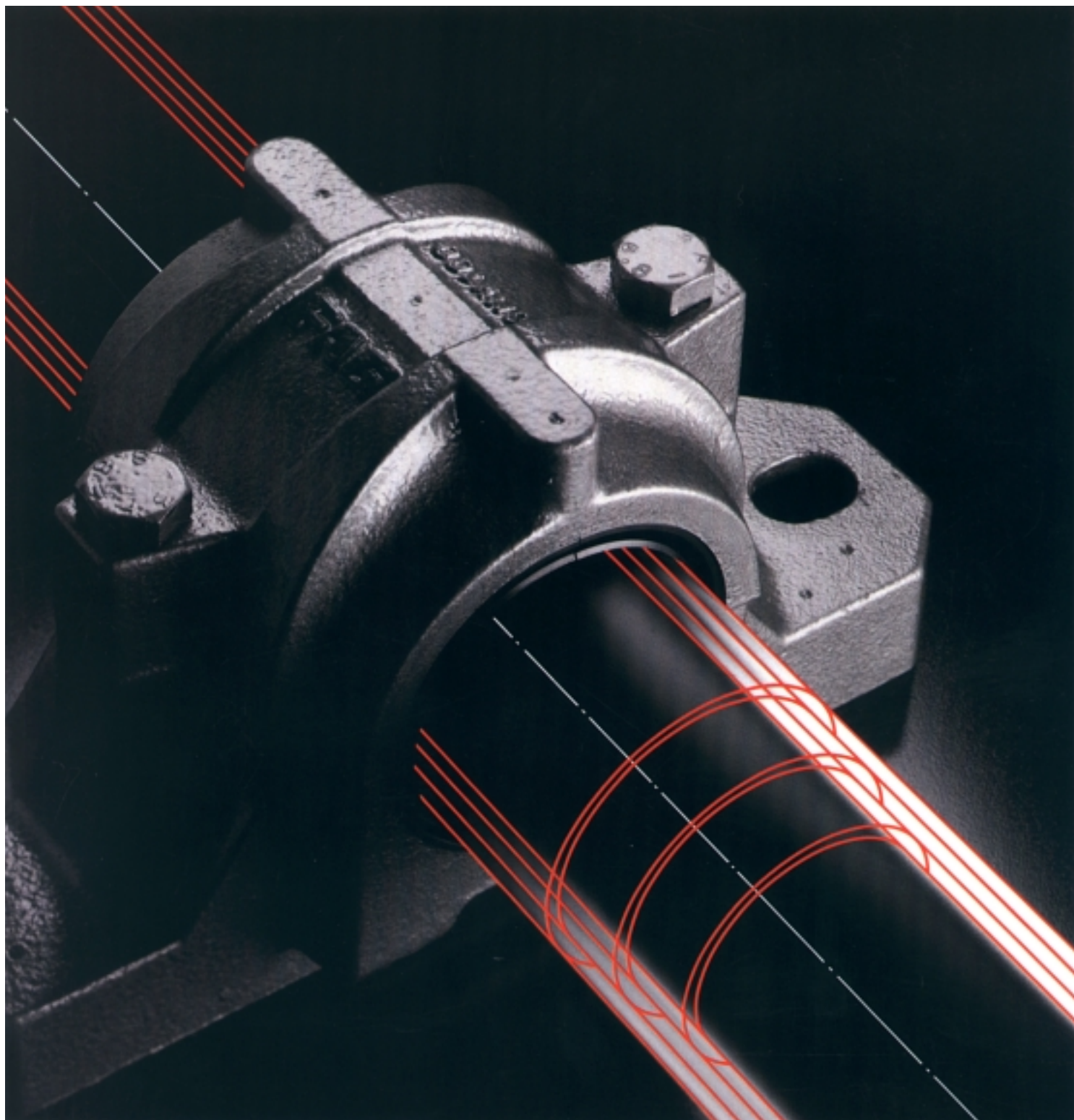

FAG Split Plummer Block Housings of Series SNV
for shaft diameters of 20 to 160 mm and $\frac{3}{4}$ to $5\frac{1}{2}$ inches

Publ. No. WL 90118/3 EA

FAG OEM und Handel AG

A Company of the FAG Kugelfischer Group

Postfach 1260 · 97419 Schweinfurt · Germany
Telephone (0 97 21) 91-0 · Fax (0 97 21) 91 34 35
Telex 67345-0 FAG d
Internet: <http://www.fag.de>

Preface

The OEM und Handel company of the FAG Kugelfischer Georg Schäfer AG Group supplies rolling bearings, necessary accessories, and services to original equipment customers in machinery and plant construction as well as to customers in the distribution and spare parts business. Comprehensive rolling bearing know-how, competent consultation on applications, and extensive customer service for more operational reliability make FAG an indispensable partner to its cus-

tomers. Development and further development of our products is based on the requirements of operation in the field. An ideal outline of requirements is best achieved through cooperation of our application engineers with the manufacturers and operators of machinery. It forms the basis for successful solutions both technically and economically speaking.

Production locations are found in Germany, Italy, Portugal, the USA and India. Sales are conducted by subsidiaries and distribution partners in almost every country in the world.



Contents

Split FAG plummer block housings of series SNV	3
Dimensions, material	4
Bearing seat and bearing mounting	4
Seals and covers	4
Lubrication	6
Mounting instructions	10
Additional holes for fastening bolts and pins	14
Loadability	14
Codes, Ordering examples	16
Dimensional tables	18

Split plummer block housings of series SNV

The FAG split plummer block housings of series SNV, fig. 1, were designed according to the modular system and developed on the basis of the SN/SNE housings. Rolling bearings of diverse diameter and width series can be mounted in any SNV housing if they have an outside diameter suitable for the housing, fig. 2.

Suitable bearing types are, for example, self-aligning ball bearings, barrel roller bearings, split and unsplit spherical roller bearings and deep groove ball bearings.

The bearings are either directly seated on the shaft or fixed with adapter sleeves. This results in different shaft diameters

for the same bearing size. Corresponding seals compensate for the gaps between the shaft and the housing passage.

FAG supplies split plummer block housings of series SNV for shafts with diameters from 20 to 160 mm and for $\frac{3}{4}$ to $5\frac{1}{2}$ inches.

The numbers in the housing codes indicate the housing bore and therefore the outside diameter of the suitable bearing e.g. 100 mm in the case of SNV100.

The main advantages of the SNV housing are:

- Easier stock-keeping due to the modular design. One housing size is suitable for different shaft diameters.
- High loadability.
- Depending on operating conditions two-lip seals, labyrinth seals, felt seals

or combined seals can be used. Special seals are available upon request.

- Centered locating bearings by means of two locating rings of identical width.
- Plane faces at housing base allow the housing to be secured with stops if high forces do not act vertically on the housing support surface.
- Holes can be drilled at spots marked on the housing for: lubricating and monitoring systems, fastening bolts, straight or tapered pins.
- Universal coating of all outer surfaces of the housing which are not machined (colour RAL 7031, blue-grey). The paint can be coated with all synthetic resin, polyurethane, acrylic, epoxy resin, chlorine rubber, cellulose, and acid-hardening hammer dimple enamels.

1: Split plummer block housing of series SNV

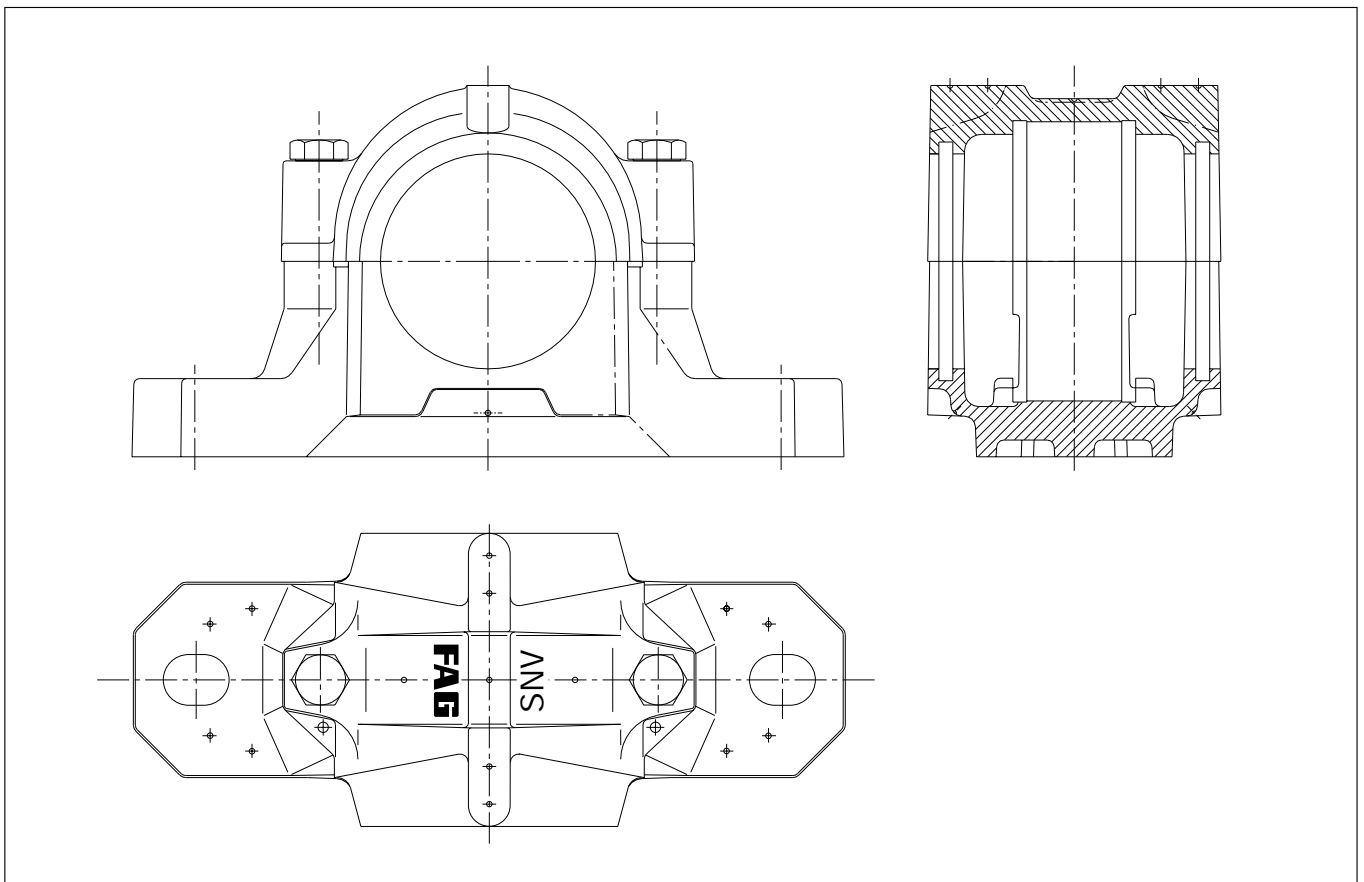

Dimensions, material

The dimensions of the FAG housings of series SNV correspond to ISO 113 and DIN 736 to DIN 739.

The SNV housings are interchangeable with the former SN/SNE housings.

The SNV housings are made of cast iron, material no. 0.6027. Their loadability is considerably higher than that of the SN/SNE housings (see "Loadability" section).

For particularly high stresses nodular cast iron, material no. 0.7040, may also be used (please inquire about availability).

Bearing seat and bearing mounting

The bearing seat in the SNV housing is machined to H7 (applies to condition on supply, i.e. prior to loosening the connecting bolts of upper and lower part). The bearings can be displaced thus acting as floating bearings. Locating bearings are obtained by inserting two FRM locating rings, one on each bearing side. The bearing is then in the centre of the housing.

Rolling bearings which are seated directly on a stepped shaft or with an adapter sleeve on a straight shaft can be fitted into SNV housings, fig. 2.

A diameter tolerance of the shaft according to h8 (h9) is permissible when fastening with adapter sleeve.

Seals and covers

Seals and covers fit into the annular grooves, with rectangular profile, on both sides of the SNV housings.

The DH two-lip seal is usually used. FAG also supplies upon request TSV labyrinth seals, FSV felt seals, TCV combined seals and special seals. The seals must be specified in the order. They are especially suitable for grease lubrication, see "Lubrication" section.

The FAG two-lip seal DH made of acrylonitrile-butadiene rubber (NBR), fig. 3a, is suitable for circumferential velocities of up to 13 m/s. The two-piece seal can be easily inserted into the annular groove of the housing (observe the position of separating joint).

2: The SNV housings are suitable for bearings with diverse diameter and width series which have the same outside diameter, e.g. 100 mm in the case of SNV100 (2a). Formerly four housing sizes were required for the shaft diameters indicated (2b).

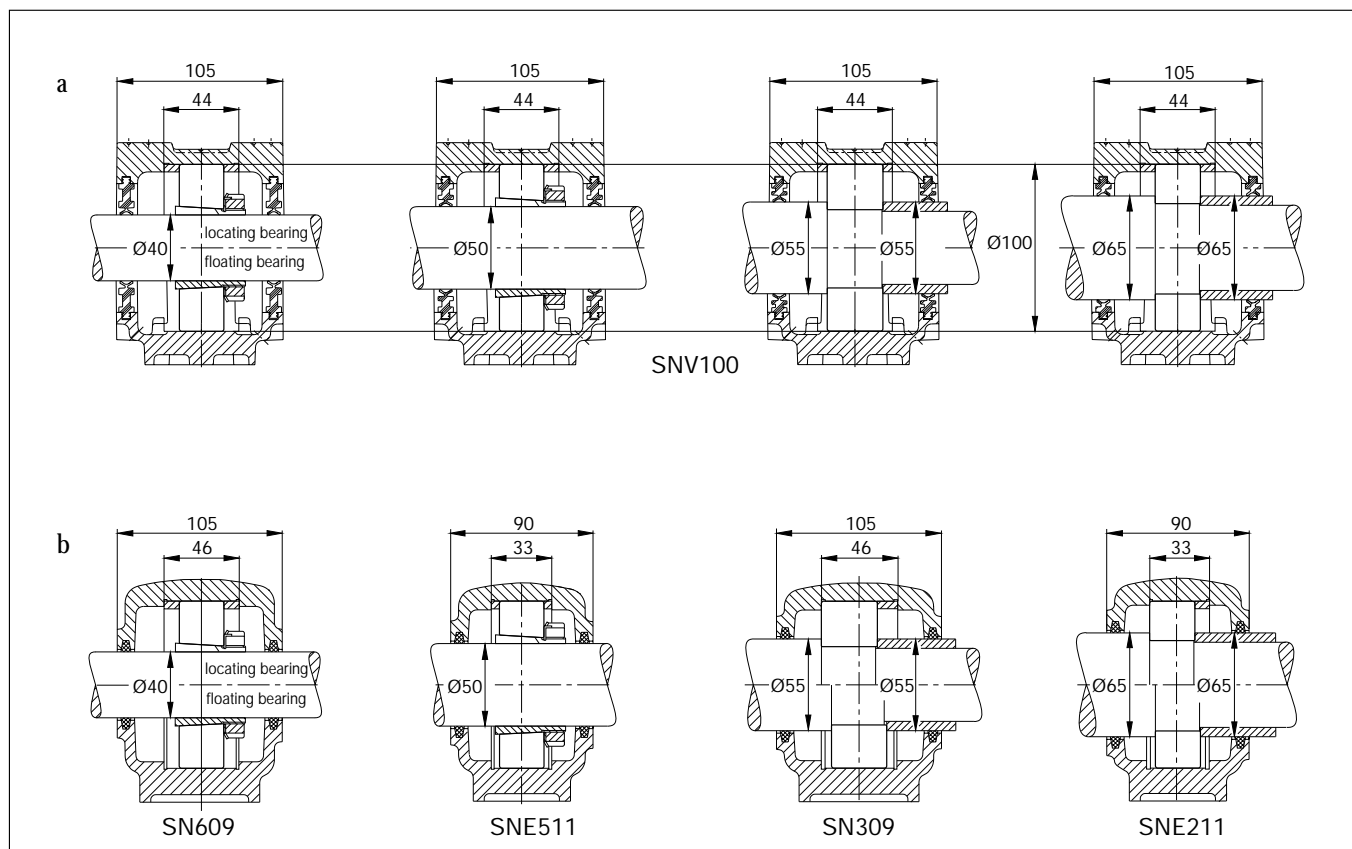

The sealing lips slide on the rotating shaft. The outer sealing lip prevents the penetration of dirt into the bearing. This is also supported by the grease filled between the two lips during mounting. The inner lip prevents the escape of grease from the housing. The two-lip seal permits shaft inclinations of up to 0.5° in both directions. It is suitable for temperatures between -40°C and $+100^\circ\text{C}$. At the contact area of the sealing lips the roughness of the shaft should correspond to class N8 (DIN ISO 1302).

FAG labyrinth rings of the series TSV, fig. 3b, are also suitable for higher circumferential velocities since they are non-

rubbing. The O ring which is pressed in between the shaft and labyrinth ring ensures that the labyrinth ring does not slip despite its loose fit. The O ring, which is made of fluoro-caoutchouc (Viton[®]), is suitable for temperatures up to 200°C . The labyrinth seal accepts shaft inclinations of up to 0.5° in both directions. The labyrinth can be relubricated at position 1 and 5, fig. 4, if required.

FAG FSV felt seals, fig. 3c, are suitable for grease lubrication and temperatures up to 100°C (aramide packages for higher temperatures available upon request). The adapter with the felt strip, which is previously soaked in oil, is secured in the

housing groove and is prevented from rotating by an O-ring. Felt seals are suitable for circumferential velocities of up to 5 m/s and, after the running-in phase, up to 15 m/s. The permissible shaft inclination is 0.5° in both directions.

Seals made up of a combination of labyrinth seat and V ring (TCV), fig. 3e, are available upon request.

If the SNV housings are to be closed on one side, the DKV covers have to be ordered separately. The synthetic covers are suitable for long-term operation at temperatures up to 120°C . DKVT covers for higher temperatures, fig. 3f, are available upon request.

3: Seals and covers for SNV housings

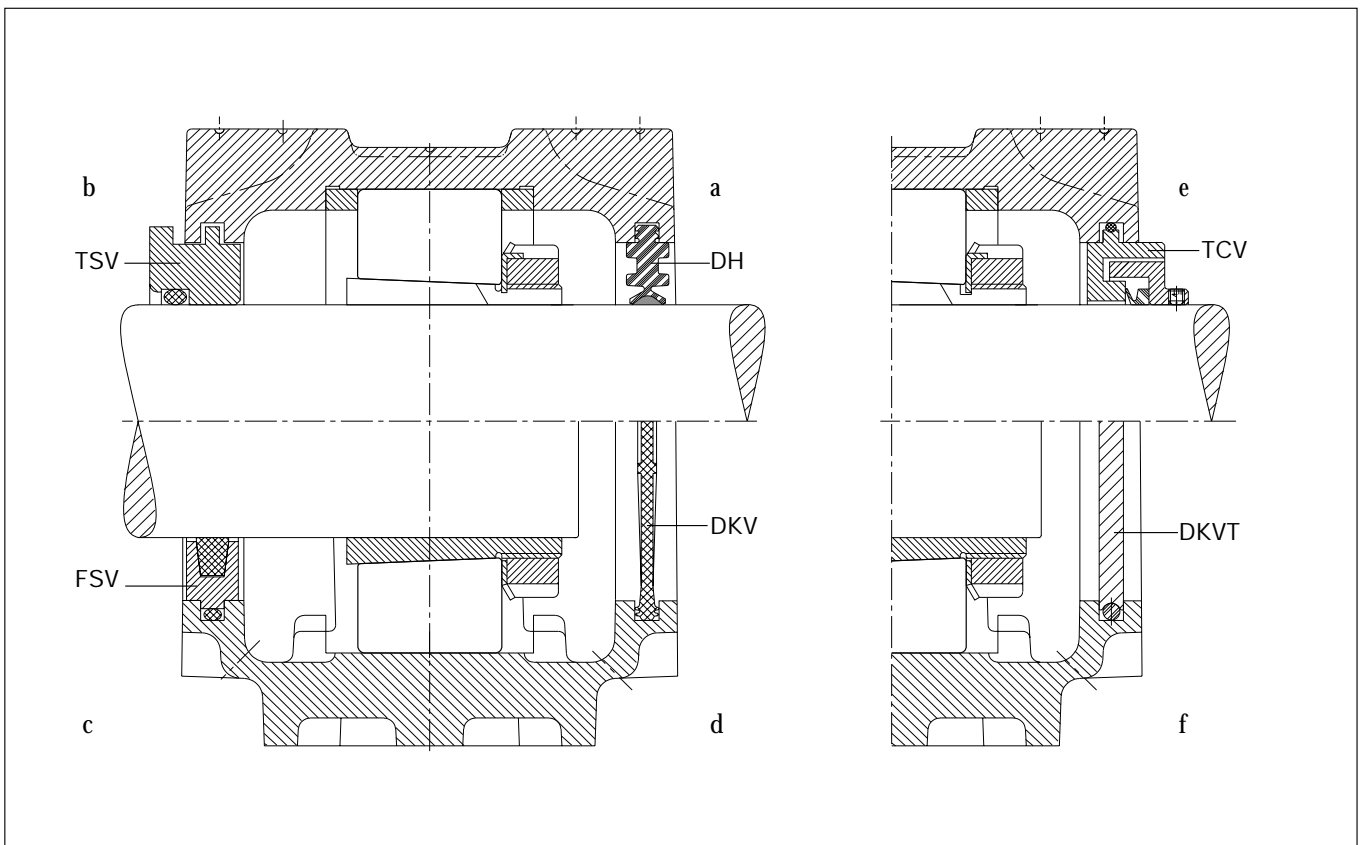

Lubrication

Lubrication

Grease lubrication

In many cases, the bearings can be greased for-life, i.e. the initial grease fill (see fig. 5 for initial grease fill amounts) will last for the entire bearing life if using rubbing seals (e.g. DH, FSV). The bearings are packed to capacity with grease and 60% of the housing cavities is filled.

The FAG rolling bearing grease Arcanol L135V, a lithium soap base grease of the NLGI class 2 with particularly effective EP additives is especially suitable (see FAG Publ. No. WL 81 116 also) for bearing operating temperatures $< 100\text{ }^{\circ}\text{C}$, bearing loads $P/C < 0.3$ and a bearing-related speed index $k_a \cdot n \cdot d_m < 700\,000\text{ min}^{-1} \cdot \text{mm}$ ($k_a = 1$ for self-aligning ball bearings and deep groove ball bearings, $k_a = 2$ for spherical roller bearings).

In the case of a speed index $n \cdot d_m < 50\,000\text{ min}^{-1} \cdot \text{mm}$ and non-rubbing sealing (e.g. TSV), where the grease also has to function as a seal, the housing and sealing cavities may be packed to capacity.

Grease change

A change of grease for new grease should be undertaken if the attainable fatigue life of the bearing is considerably longer than the grease service life (to be found in FAG Publ. No. WL 81 115 "Rolling Bearing Lubrication").

Grease relubrication Grease outlet hole

If, in isolated cases, the grease exchange intervals are too short, relubrication is recommended. The lubricant can be supplied to the housing laterally or where bearings with lubricating groove and holes are used also centrally. In the case of lateral lubrication the housing cavities on the side of the grease nipple must be filled to about 100% so that the

replenished grease reaches the bearing immediately. Depending on the seal type selected and on the application in question, the housing top can be provided with grease nipples for lubricant supply at positions 2 or 4, fig. 4, and on the opposite side of the housing base the grease outlet hole can be provided (an absolute must for DH seals).

The grease nipple and outlet hole are specified in the order by adding the suffix G944A* to the housing code. Please refer

to fig. 6 for the location and dimensions of the holes and the grease nipple.

The far right column of fig. 5 indicates the minimum relubrication quantities. It is not possible to overgrease the bearings if there is a grease outlet hole or non rubbing sealing. The temperature may rise due to the working of the replenished grease. It will drop to its original level after a few running hours when the surplus grease has been expelled. In the interest of the environment it is recommended to dose the lubricant.

4: Markings at the housing top for grease nipple connecting holes

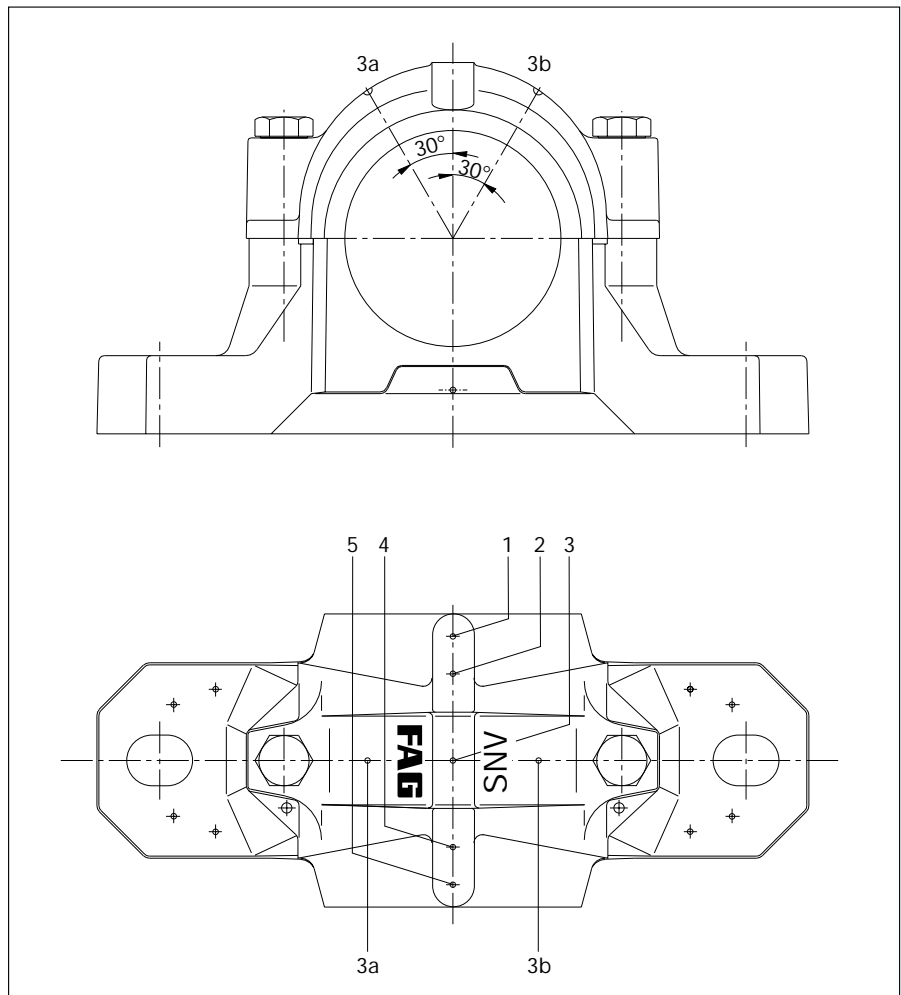

Due to their good flow behaviour, greases of consistency class 2, e.g. Arcanol L135V and L78V, are more suitable for replenishment than greases of higher consistency classes.

5: Recommended grease quantities for the initial grease fill (housing cavities 60%, bearings packed to capacity) and the relubrication of SNV housings

Housing	Grease quantity	
	Initial fill g	Re-lubrication
FAG		
SNV052	30	5
SNV062	45	5
SNV072	65	10
SNV080	80	10
SNV085	105	10
SNV090	130	10
SNV100	180	15
SNV110	210	15
SNV120	270	20
SNV125	290	20
SNV130	330	20
SNV140	440	25
SNV150	500	30
SNV160	650	40
SNV170	700	45
SNV180	900	55
SNV190	950	60
SNV200	1200	70
SNV215	1400	80
SNV230	1600	85
SNV240	1700	90
SNV250	2000	100
SNV260	2000	120
SNV270	2500	130
SNV280	2600	140
SNV290	3000	150
SNV300	3100	160
SNV320	3700	200
SNV340	4500	240

6: Dimensions recommended for grease nipple connecting holes and grease outlet holes

SNV housings for grease replenishment (suffix G944A*, supply on request) are equipped with a grease nipple and an outlet hole of the sizes shown in the table.
Example: Design G944AA with conical grease nipple NIP.DIN71412-AM10x1.

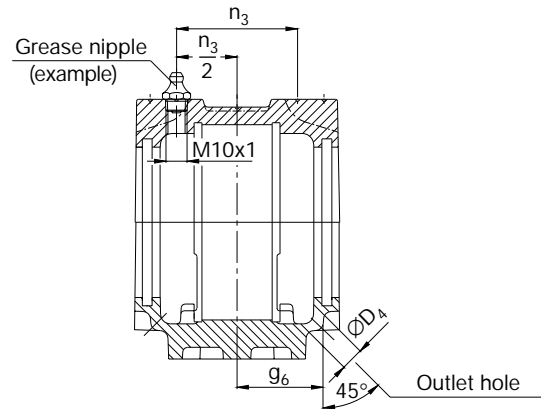

Housing	Connection for grease nipple	Grease outlet hole	
	$\frac{n_3}{2}$ mm	D_4 mm	g_6 mm
FAG			
SNV052	19	10	27.5
SNV062	21	10	30
SNV072	23	10	33
SNV080	26	10	36
SNV085	23.5	10	34.5
SNV090	29	10	41.5
SNV100	31	15	44
SNV110	33.5	15	46
SNV120	35.5	15	49
SNV125	28.5	10	41
SNV130	38	15	51.5
SNV140	40.5	15	57.5
SNV150	42.5	15	60
SNV160	45	15	62.5
SNV170	46.5	20	64
SNV180	49.5	20	69
SNV190	49.5	20	68.5
SNV200	55.5	20	77.5
SNV215	58.5	20	80
SNV230	61	20	83
SNV240	60	20	81.5
SNV250	65.5	20	89
SNV260	62.5	20	84
SNV270	71.5	20	96.5
SNV280	68	20	92.5
SNV290	76	20	102.5
SNV300	73	20	99.5
SNV320	77	20	104.5
SNV340	81	20	109.5

Lubrication

Grease valves

For high-speed operation, e.g. with fan bearing arrangements, FAG supply RSV grease valves upon request, fig. 7.

Grease valves for SNV housings of design G944A* must be listed separately in the order. RSV5 or RSV6 grease valves are used for bearings with adapter sleeves while RSV2 or RSV3 valves are used for bearings with cylindrical bore.

7: RSV grease valve

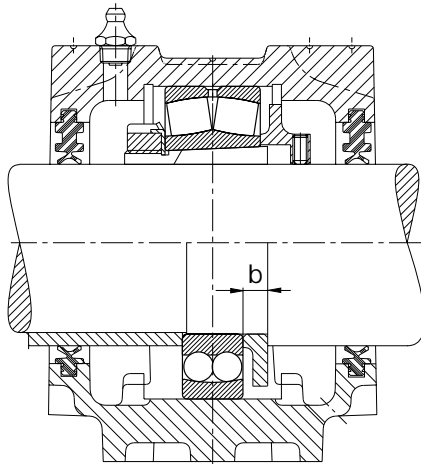

Grease valve	Width b mm	Grease valves	Width b mm
FAG		FAG	
RSV205 to 211	8	RSV305 to 308	8
RSV212 to 218	10	RSV309 to 313	10
RSV219 to 222	13	RSV314 to 316	13
RSV224 to 232	15	RSV317 to 322	15
		RSV324 to 332	16

Oil lubrication

The SNV housings are designed for both oil sump and circulation oil lubrication. The housings are spacious with oil collecting pockets in the base, oil inlet and outlet holes, holes for connecting oil level gauges and temperature sensors. Connection dimensions fig. 8.

In the case of oil sump lubrication a minimum oil level must be maintained (h_3 dimension in fig. 8). If FAG two-lip seals are used, a certain leakage must be taken into account. Leakage is inevitable with split seals and with seals which are not spring-preloaded. To keep the leakage rate down, the seal contact surface on the shaft should have the following quality:

hardness at least 55 HRC,

ground twist-free with $R_a = 0.2 \mu\text{m}$ to max. $0.5 \mu\text{m}$.

The joint between housing top and base must be sealed with a thin layer of a commercial sealing compound (permanent elasticity). In the case of housings closed at one end, the groove bottom must also be filled with the sealing compound.

Technically-speaking, an oil-proof design is only possible with a spring-preloaded, unsplit radial shaft seal. Please note: the housing must be ventilated in the case of oil sump lubrication (e.g. closing the inlet hole with a ventilation plug). Please contact the FAG advisory service about design and availability.

8: Dimensions recommended for the connecting holes of oil inlet, oil outlet and oil-sight glass for oil sump lubrication.
For oil circulation lubrication the bore M_4 can be used as the oil outlet.

SNV housings for oil sump lubrication (suffix G944BA) contain
 1 Oil-sight glass OSGL.MOD24OMR-R./...,
 1 Vent VENT.MOD556E-R./...,
 2 Plugs VSB.DIN906-M10x1-ST.
 FAG supply the G944BA design upon request.

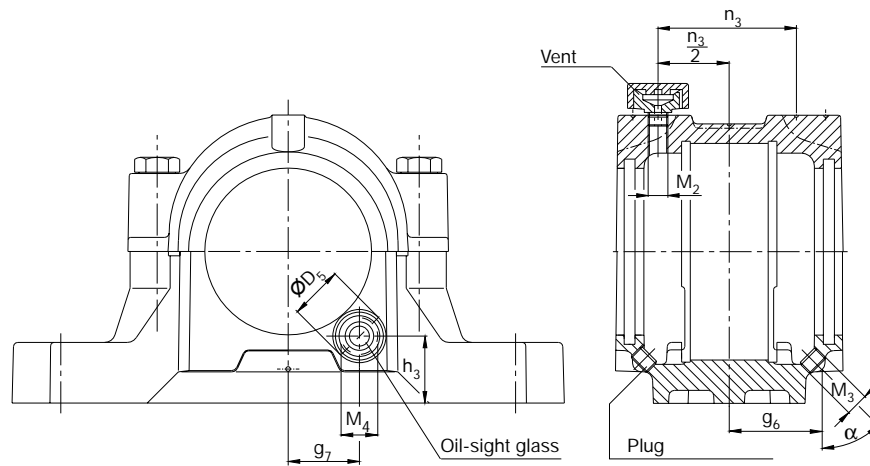

Housing	Connection for oil inlet		Connection for oil outlet			Connection for oil-sight glass			
	M_2	$\frac{n_3}{2}$ mm	M_3	α °	g_6 mm	M_4	g_7 mm	h_3	D_5
SNV100	G ^{1/4}	31	M10x1	50	44	G ^{3/8}	33	31	25
SNV110	G ^{1/4}	33.5	M10x1	50	46	G ^{3/8}	35	28	25
SNV120	G ^{1/4}	35.5	M10x1	50	49	G ^{3/8}	38	35	25
SNV125	G ^{1/4}	28.5	M10x1	50	49	G ^{3/8}	44	24	25
SNV130	G ^{1/4}	38	M10x1	50	51.5	G ^{1/2}	43	28.5	30
SNV140	G ^{1/4}	40.5	M10x1	60	57.5	G ^{1/2}	45	40	30
SNV150	G ^{1/4}	42.5	M10x1	60	60	G ^{1/2}	47	38	30
SNV160	G ^{1/4}	45	M10x1	60	62.5	G ^{1/2}	50	39	30
SNV170	G ^{1/4}	46.5	M10x1	60	64	G ^{3/4}	55	46	38
SNV180	G ^{1/4}	49.5	M10x1	60	69	G ^{3/4}	57	43	38
SNV190	G ^{1/4}	49.5	M10x1	60	68.5	G ^{3/4}	48	45	38
SNV200	G ^{1/4}	55.5	M10x1	60	77.5	G ^{3/4}	62	50	38
SNV215	G ^{1/4}	58.5	M10x1	60	80	G ^{3/4}	67	58	38
SNV230	G ^{1/4}	61	M10x1	60	83	G ^{3/4}	70	60	38
SNV240	G ^{1/4}	60	M10x1	60	81.5	G ^{3/4}	61	60	38
SNV250	G ^{1/4}	65.5	M10x1	60	89	G ^{3/4}	75	55	38
SNV260	G ^{1/4}	62.5	M10x1	60	84	G ^{3/4}	65	65	38
SNV270	G ^{1/4}	71.5	M10x1	60	96.5	G ^{3/4}	81	55	38
SNV280	G ^{1/4}	68	M10x1	60	92.5	G ^{3/4}	70	60	38
SNV290	G ^{1/4}	76	M10x1	60	102.5	G ^{3/4}	87	58	38
SNV300	G ^{1/4}	73	M10x1	60	99.5	G ^{3/4}	75	70	38
SNV320	G ^{1/4}	77	M10x1	60	104.5	G ^{3/4}	80	73	38
SNV340	G ^{1/4}	81	M10x1	60	109.5	G ^{3/4}	95	75	38

Mounting

Mounting instructions

Correct mounting has a decisive influence on the attainable life of the bearing.

Careful attention should therefore be paid to the following mounting instructions. Further information can be found in the FAG Publ. No. WL 80 100 "Mounting and Dismounting of Rolling Bearings".

The bearings which fit into the SNV housings can be fastened onto the shaft with adapter sleeves or seated directly on the shaft with a cylindrical bore. The required machining tolerances of the shaft can be taken from the catalogue WL 41 520 "FAG Rolling Bearings". When using adapter sleeves, the tight fit is obtained by pushing the inner ring axially onto the shaft and from the resulting radial expansion of the inner ring. The axial displacement or reduction in radial clearance of the bearing is the dimension (see table 9 for recommended

values). Pressing on is facilitated by using an FAG hydraulic nut.

In the case of spherical roller bearings the reduction in radial clearance is determined by measuring the remaining clearance with feeler gauges. Self-aligning ball bearings are pressed so far onto the sleeve until a slight resistance can be felt when the outer ring is swivelled out. However, the outer ring must be easy to rotate in circumferential direction.

Housing tops and bases are not interchangeable.

The support surface must first be cleaned and checked for flatness prior to mounting the SNV plummer block housings.

See section "Loadability", page 14, for flatness tolerances (DIN ISO 1101).

The housing base, which has been cleaned, is then fixed to the support surface with the fastening bolts. The bolts should not be fully tightened so that the housing can be adjusted at a later stage.

Mounting the bearings on the shaft

Bearings with a cylindrical bore are pressed onto the shaft or, even better, pushed on in heated condition. The bearing inner ring must abut the shaft shoulder accurately. If necessary, press again after cooling.

When mounting bearings with tapered bores and adapter sleeves it must be ensured that the bearing is seated in the centre of the housing before fixing. This is achieved by inserting the shaft with the bearing in the housing base and adjusting it. Axial displacement of the bearing on the sleeve must also be taken into consideration.

Mounting split spherical roller bearings

Split FAG spherical roller bearings are mounted similarly. Particularities for mounting split bearings are enclosed with the bearings upon delivery.

9: Reduction in radial clearance for FAG spherical roller bearings with tapered bore

Nominal bore		Radial clearance prior to mounting Clearance group						Reduction in radial clearance ¹⁾				Axial displacement on the taper 1:12 ¹⁾				Control value for the radial clearance after mounting		
d	to	CN (normal)		C3		C4				Shaft		Sleeve		CN	C3	C4		
over		min	max	min	max	min	max	min	max	min	max	min	max	min	min	min		
mm	mm	mm	mm	mm	mm	mm	mm	mm	mm	mm	mm	mm	mm	mm	mm	mm		
24	30	0.03	0.04	0.04	0.055	0.055	0.075	0.015	0.02	0.3	0.35	0.3	0.4	0.015	0.02	0.035		
30	40	0.035	0.05	0.05	0.065	0.065	0.085	0.02	0.025	0.35	0.4	0.35	0.45	0.015	0.025	0.04		
40	50	0.045	0.06	0.06	0.08	0.08	0.1	0.025	0.03	0.4	0.45	0.45	0.5	0.02	0.03	0.05		
50	65	0.055	0.075	0.075	0.095	0.095	0.12	0.03	0.04	0.45	0.6	0.5	0.7	0.025	0.035	0.055		
65	80	0.07	0.095	0.095	0.12	0.12	0.15	0.04	0.05	0.6	0.75	0.7	0.85	0.025	0.04	0.07		
80	100	0.08	0.11	0.11	0.14	0.14	0.18	0.045	0.06	0.7	0.9	0.75	1	0.035	0.05	0.08		
100	120	0.1	0.135	0.135	0.17	0.17	0.22	0.05	0.07	0.7	1.1	0.8	1.2	0.05	0.065	0.1		
120	140	0.12	0.16	0.16	0.2	0.2	0.26	0.065	0.09	1.1	1.4	1.2	1.5	0.055	0.08	0.11		
140	160	0.13	0.18	0.18	0.23	0.23	0.3	0.075	0.1	1.2	1.6	1.3	1.7	0.055	0.09	0.13		

¹⁾ Only applicable to solid shafts made of steel and to hollow shafts with a bore not larger than half the shaft diameter.

The following applies: Bearings, whose radial clearance lies in the upper half of the tolerance range prior to mounting, are mounted with the higher value of the radial clearance reduction or axial displacement, bearings in the lower half of the tolerance range with the lower value of the radial clearance reduction or axial displacement.

Mounting sequence for SNV housings with the two-lip seal DH (fig. 10)

1. Clean and check support surface.
2. Lock housing base into position.
3. Mount bearing on shaft and fill its cavities with some of the grease quantity according to table 5.
4. Fill space between the sealing lips with grease. Place each of the sealing halves in the grooves of the housing base.
5. Insert shaft with bearing in housing base. Insert both locating rings for locating bearing. The floating bearing should be positioned in the housing centre. In the case of housings closed at one end insert only one seal and, at the opposite side, the cover DKV into the housing grooves.
6. Align housing base and tighten fastening bolts in housing foot with recommended tightening torque, table 13.
7. Distribute equally the remaining bearing grease (point 3) between housing top and base.
8. Insert greased seal halves into the grooves of housing top.
9. Mount housing top and tighten fastening bolts with recommended tightening torque, table 13.

10: Mounting of SNV housings with two-lip seals DH

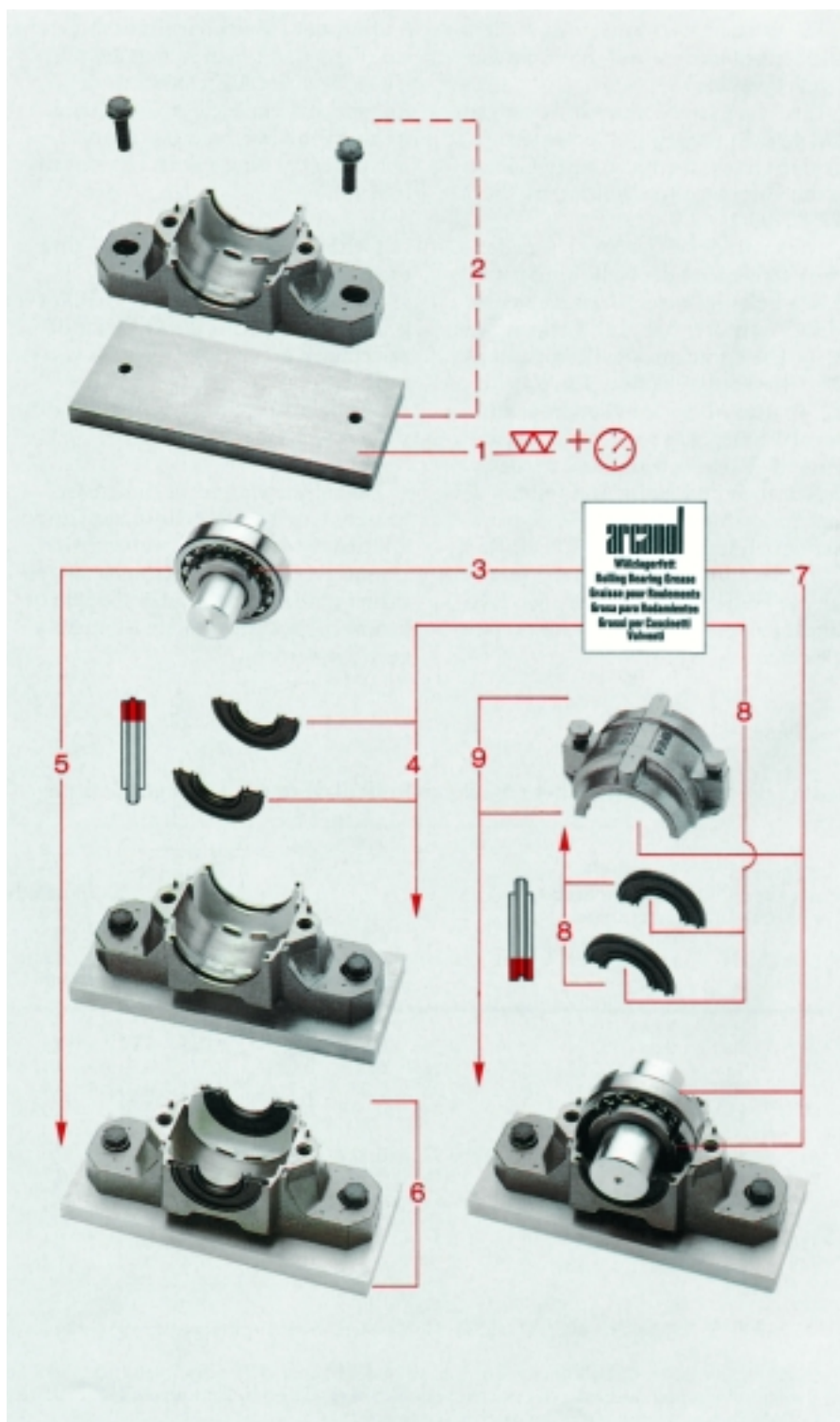

Mounting

Mounting sequence for SNV housings with the felt seal FSV (fig. 11)

1. Clean and check support surface.
2. Lock housing base into position.
3. Insert O rings into the grooves of housing base.
4. Place each half of the adapter with oil-soaked felt strip on the O ring in the grooves of housing base.
5. Mount bearing on shaft and fill its cavities with some of the grease quantity according to table 5.
6. Insert shaft with mounted bearing in housing base. Insert both locating rings for locating bearing. The floating bearing should be positioned in the housing centre. In the case of housings closed at one end insert only one adapter with felt strip and, at the opposite side, the cover DKV into the housing grooves.
7. Align housing base and tighten fastening bolts in housing foot with the recommended tightening torque, table 13.
8. Distribute equally the remaining bearing grease (point 5) between the housing top and base.
9. Insert O ring and adapter with oil-soaked felt strip into the grooves of housing top.
10. Mount housing top and tighten fastening bolts with the recommended tightening torque, table 13.

11: Mounting of SNV housings with felt seals FSV

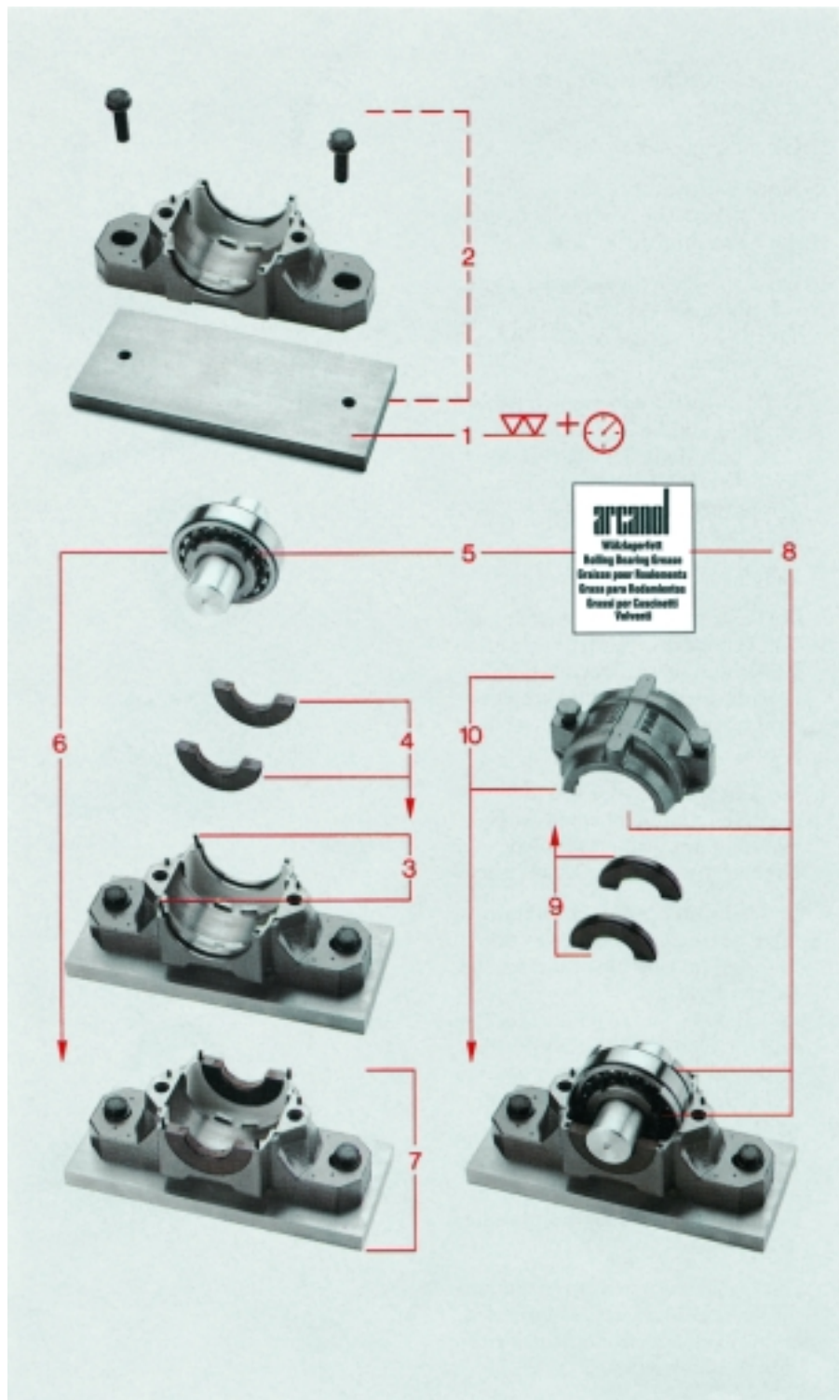

Mounting sequence for SNV housings with the labyrinth seal TSV (fig. 12)

1. Clean and check support surface.
2. Lock housing base into position.
3. Push one labyrinth ring onto shaft. The groove in the bore of the ring must be on the outside.
4. Mount bearing on shaft and fill its cavities with some of the grease quantity according to table 5.
5. If necessary, push the second labyrinth ring onto shaft (note position). For bearings closed at one end place the cover DKV into the housing groove.
6. Grease labyrinth.
7. Insert shaft with mounted bearing and labyrinth rings in housing base. Insert both locating rings for locating bearing. The floating bearing should be positioned in the housing centre.
8. Align housing base and tighten fastening bolts in housing foot with the recommended tightening torque, table 13.
9. The bores of the labyrinth rings have an annular groove. An O ring is forced into the groove by simultaneously turning the shaft with a screwdriver. Then adjust the distance between the labyrinth rings and the housing grooves so that equal axial gaps are obtained.
10. Distribute equally the remaining bearing grease (point 4) between the housing top and base.
11. Mount housing top and tighten fastening bolts with the recommended tightening torque, table 13.

12: Mounting of SNV housings with labyrinth seals TSV

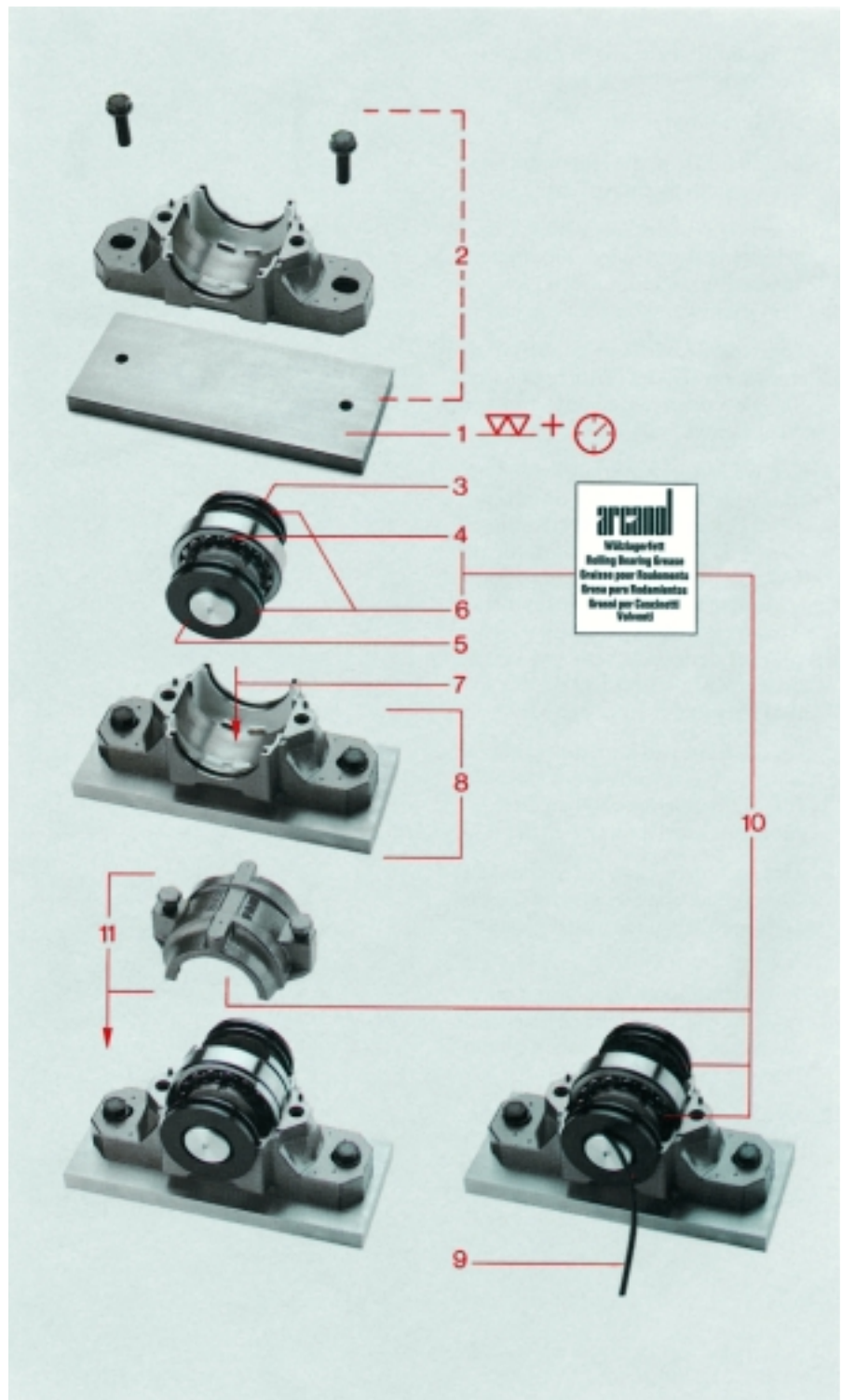

Additional holes for fastening bolts and pins · Loadability

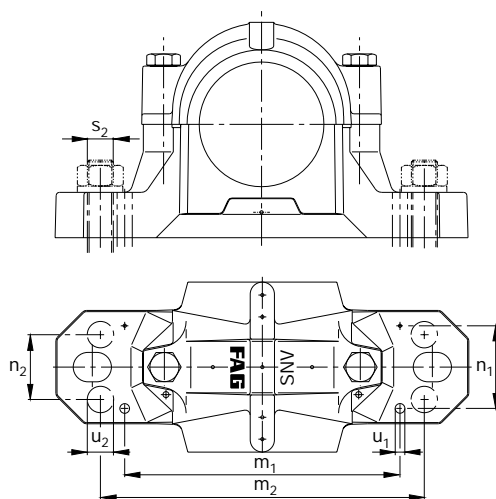

Additional holes for fastening bolts and pins

SNV housings are normally fastened with two bolts. The housing base has two slots which allow the housings to be aligned during mounting (dimensions m , u , v from page 18 on).

Four bolts are required for fastening on T section supports. Spots (dimensions m_2 and n_2) are marked where additional holes (diameter u_2) can be drilled for fastening bolts (s_2). FAG supply upon request housings from size SNV080 on with these four additional holes for fastening bolts. The order should then be, for example: FAG plummer block housing SNV080.G944DA.

Holes (diameter u_1) can be drilled at the marked spots (dimensions m_1 , n_1) for pins to secure the bearing positions.

Housing Code	Dimensions for pins			Dimensions for bolts				inch
	m_1	n_1	u_1	m_2	n_2	u_2	s_2	
FAG	mm			mm				
SNV052	95	32	4	115	25			
SNV062	115	36	4	130	25			
SNV072	115	37	4	135	25			
SNV080	135	43	4	160	34	11	M10	3/8
SNV085	135	40	4	160	34	11	M10	3/8
SNV090	135	44	6	160	34	11	M10	3/8
SNV100	170	51	6	200	40	14	M12	1/2
SNV110	170	52	6	200	40	14	M12	1/2
SNV120	190	58	6	220	48	14	M12	1/2
SNV125	190	52	4	220	48	14	M12	1/2
SNV130	190	60	8	220	48	14	M12	1/2
SNV140	210	65	8	252	52	18	M16	5/8
SNV150	210	66	8	252	52	18	M16	5/8
SNV160	240	72	8	280	58	18	M16	5/8
SNV170	240	74	8	280	58	18	M16	5/8
SNV180	261	80	8	300	66	18	M16	5/8
SNV190	271	81	8	300	66	18	M16	5/8
SNV200	291	88	8	320	74	18	M16	5/8
SNV215	297	91	8	330	74	18	M16	5/8
SNV230	325	97	10	370	80	22	M20	3/4
SNV240	328	96	10	370	80	22	M20	3/4
SNV250	342	109	12	400	92	26	M24	7/8
SNV260	372	113	12	430	100	26	M24	7/8
SNV270	372	116	12	430	100	26	M24	7/8
SNV280	392	114	12	450	100	26	M24	7/8
SNV290	392	120	12	450	100	26	M24	7/8
SNV300	442	123	12	500	100	26	M24	7/8
SNV320	482	130	12	540	100	26	M24	7/8
SNV340	489	138	14	570	100	33	M30	1 1/4

Loadability

The breaking loads of the SNV housings based on the load direction are indicated in table 13, page 15.

These values apply if the support surfaces of the mating parts are finished with a flatness tolerance of IT8 according to DIN ISO 1101 (related to distance a). An overall and rigid support of the housing base is a precondition for the accommodation of the loads. The common safety factors which apply in general in mechanical engineering must be taken into consideration when determining the values for the permissible load (see page 16).

13: Standard values for the breaking load of SNV housings and the maximum loadability of connecting bolts

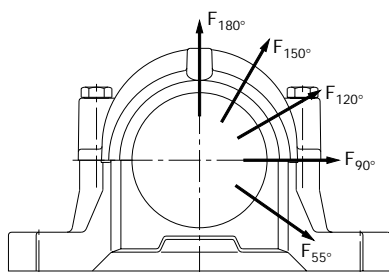

For compensation of the housing breaking load value a safety factor of 6 is recommended.

Housing Code	Housing breaking load in load direction					Connecting bolts					Holding-down bolts*)	
	55°	90°	120°	150°	180°	Designation according to DIN 931	Maximum loadability of both bolts with contact of joint surfaces in load direction			Tightening torque**) Mat. 8.8	Designation according to DIN 931	Tightening torque**) Mat. 8.8
FAG	kN					Material 8.8	120°	150°	180°	N m	Mat. 8.8	N m
SNV052	160	95	70	60	80	M10x40	60	35	30	50	M12	85
SNV062	170	100	80	65	85	M10x50	60	35	30	50	M12	85
SNV072	190	110	85	80	95	M10x50	60	35	30	50	M12	85
SNV080	210	130	95	85	105	M10x50	60	35	30	50	M12	85
SNV085	225	140	100	90	120	M10x50	60	35	30	50	M12	85
SNV090	265	160	120	105	130	M10x50	60	35	30	50	M12	85
SNV100	280	170	125	120	140	M12x60	80	45	40	85	M16	210
SNV110	300	180	130	125	150	M12x60	80	45	40	85	M16	210
SNV120	335	200	150	130	170	M12x70	80	45	40	85	M16	210
SNV125	335	200	150	130	170	M12x70	80	45	40	85	M16	210
SNV130	400	250	180	150	200	M12x70	80	45	40	85	M16	210
SNV140	425	265	190	170	210	M12x70	80	45	40	85	M20	410
SNV150	475	280	200	180	235	M12x80	80	45	40	85	M20	410
SNV160	530	335	250	210	265	M16x90	180	100	90	210	M20	410
SNV170	560	355	265	225	280	M16x90	180	100	90	210	M20	410
SNV180	630	375	280	250	300	M20x110	260	150	130	410	M24	710
SNV190	630	375	280	250	300	M20x110	260	150	130	410	M24	710
SNV200	670	400	315	280	335	M20x110	260	150	130	410	M24	710
SNV215	800	450	355	315	400	M20x110	260	150	130	410	M24	710
SNV230	900	530	400	355	450	M24x130	360	210	180	710	M24	710
SNV240	1000	600	450	400	500	M24x130	360	210	180	710	M24	710
SNV250	1060	630	475	425	530	M24x130	360	210	180	710	M30	1450
SNV260	1180	710	530	475	600	M24x130	360	210	180	710	M30	1450
SNV270	1180	710	530	475	600	M24x130	360	210	180	710	M30	1450
SNV280	1320	750	600	530	630	M24x140	360	210	180	710	M30	1450
SNV290	1400	850	630	560	710	M24x140	360	210	180	710	M30	1450
SNV300	1500	900	670	600	750	M24x140	360	210	180	710	M30	1450
SNV320	1700	1000	750	670	850	M24x150	360	210	180	710	M30	1450
SNV340	1900	1120	850	750	950	M30x160	640	370	320	1450	M36	2600

*) Holding-down bolts are not supplied by FAG.

**) The tightening torques are maximum values at a 90% utilization of the yield strength of the bolt material and a coefficient of friction of 0.14. We recommend tightening the bolts to 70% of these values.

The safety factors are:

- 6 for the breaking load of the housing
- 3 for the maximum loadability of connecting bolts and holding-down bolts.

The maximum axial housing load is assumed to be two thirds of the breaking load value F_{180° . In this case the permissible axial loadability of the bearings used and the axial holding force of bearings on sleeves without positive contact must be considered (see FAG TI No. WL 80-14). For load directions between 55° and 120° or for axial load the housing must be secured at the foot with stops in the load direction if the force acting parallel to the clamping surface exceeds $0.05 \cdot F_{180^\circ}$.

The maximum permissible load on eyebolts in the housing top is the weight of the housing together with the bearing.

Codes

The housing code is made up of the designation of the housing series SNV and the bearing outside diameter in mm, e.g. SNV100.

Bearings and adapter sleeves, locating rings, seals and covers must be ordered separately (see following examples of how to order). The accessories required for the housing based on the bearing provided are indicated in the dimension tables.

Examples of how to order

EXAMPLE 1

Plummer block housing, closed on one side, self-aligning ball bearing 2210K.TV.C3 as a locating bearing, adapter sleeve, two-lip seal.

Order:
1 plummer block housing FAG SNV090
1 self-aligning ball bearing FAG 2210K.TV.C3
1 adapter sleeve FAG H310
2 locating rings FAG FRM90/9
1 cover FAG DKV090
1 two-lip seal FAG DH510

EXAMPLE 2

Plummer block housing for through shaft, spherical roller bearing 22212EK as a floating bearing, adapter sleeve, two-lip seals.

Order:
1 plummer block housing FAG SNV110
1 spherical roller bearing FAG 22212EK
1 adapter sleeve FAG H312
2 two-lip seals FAG DH512

EXAMPLE 3

Plummer block housing for through shaft, split spherical roller bearing 222SM70T as a locating bearing, two-lip seal.

Order:
1 plummer block housing FAG SNV140
1 split spherical roller bearing FAG 222SM70T
2 locating rings FAG FRM140/12,5
2 two-lip seals FAG DH516

EXAMPLE 4

Plummer block housing with labyrinth seal, one end closed, spherical roller bearing 22216EK as a floating bearing, adapter sleeve.

Order:
1 plummer block housing FAG SNV140
1 spherical roller bearing FAG 22216EK
1 adapter sleeve FAG H316
1 labyrinth ring FAG TSV516
1 cover FAG DKV140

EXAMPLE 5

Plummer block housing, one end closed, spherical roller bearing 23218ES.TVPB as a floating bearing, felt seal.

Order:
1 plummer block housing FAG SNV160
1 spherical roller bearing FAG 23218ES.TVPB
1 shaft nut FAG KM18
1 lock washer FAG MB18A
1 cover FAG DKV160
1 felt seal FAG FSV218

FAG Plummer Block Housings, split

for bearings with cylindrical bore and
for bearings with tapered bore and adapter sleeve

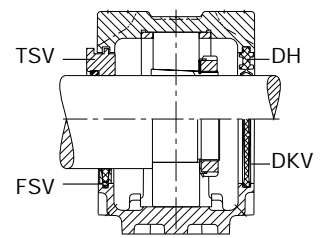
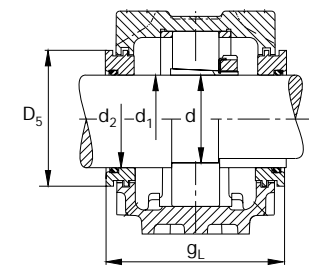
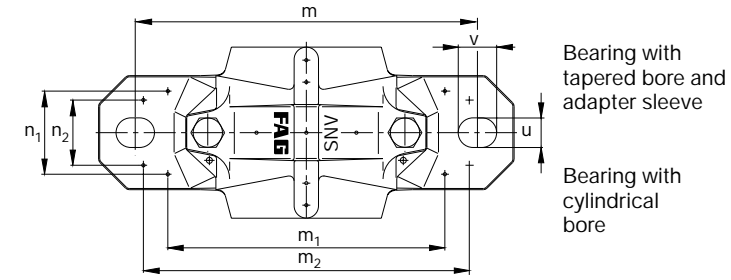
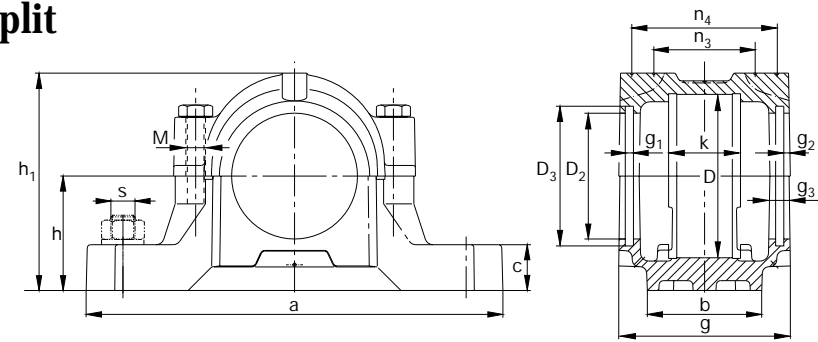

SNV052

Dimensions																						Mass						
D	a	b	c	g	h	m	s	u	v	h ₁	D ₂	D ₃	D ₅	g ₁	g ₂	g ₃	g _L	k	m ₁	n ₁	m ₂	n ₂	n ₃	n ₄	M DIN 931	M ₁ DIN 580	≈ kg	
mm							mm	inch	mm																			
52	165	46	19	70	40	130	M12	1/2	15	20	75	36.5	44.5	42.7	5	3	10.5	83 ¹⁾	27	95	32	115	25	38	56	M10	-	1.3

Shaft d ₁ d	d ₂	Bearings which fit the housing		Split spherical roller bearing	Required accessories											
		Unsplit bearings	Codes according to DIN*		FAG	Adapter sleeve	Locknut	Lock washer	Locating ring 2 pieces	Two-lip seal	Labyrinth ring with O ring FAG	Felt seal	Cover			
mm	inch	mm		FAG	FAG	FAG	FAG	FAG	FAG	FAG	FAG	FAG	FAG	FAG	FAG	FAG
19.05	3/4		1205K 20205K		H205.012 H305.012					FRM52/6 FRM52/4,5	DH505.012 DH505.012	TSV505.012 TSV505.012	FSV505.012 FSV505.012	DKV052 DKV052		
20		25 25	6304 1304 20304 21304	2205K 22205K	H205 H305		KM4 KM4	MB4A MB4A		FRM52/6 FRM52/4,5 FRM52/6 FRM52/3	DH505 DH505 DH304 DH304	TSV505 TSV505 TSV304 TSV304	FSV505 FSV505 FSV304 FSV304	DKV052 DKV052 DKV052 DKV052		
20.638	13/16		1205K 20205K	2205K 22205K	H205.013 H305.013					FRM52/6 FRM52/4,5	DH505 DH505	TSV505.013 TSV505.013	FSV505 FSV505	DKV052 DKV052		
25		30 30	6205 1205 20205	2205 22205			KM5 KM5	MB5A MB5A		FRM52/6 FRM52/4,5	DH205 DH205	TSV205 TSV205		DKV052 DKV052		

* The order designation in the code according to DIN can be taken from the catalogue WL 41520EA "FAG Rolling Bearings"

¹⁾ 95 mm at TSV205 and TSV304

FAG Plummer Block Housings, split

for bearings with cylindrical bore and
for bearings with tapered bore and adapter sleeve

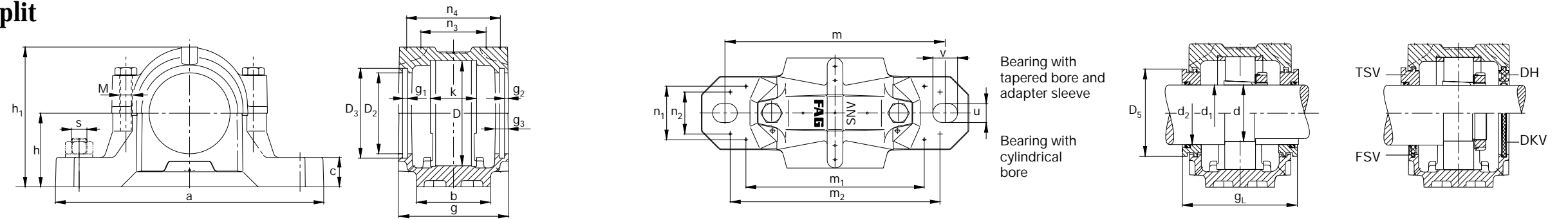

SNV062

Dimensions																						Mass					
D	a	b	c	g	h	m	s	u	v	h ₁	D ₂	D ₃	D ₅	g ₁	g ₂	g ₃	g _L	k	m ₁	n ₁	m ₂	n ₂	n ₃	n ₄	M DIN 931	M ₁ DIN 580	≈ kg
mm							mm inch	mm																			
62	185	52	22	75	50	150	M12 1/2	15	20	91	41.5	49.5	47.7	5	3	10.5	88 ¹⁾	30	115	36	130	25	42	61	M10	-	1.9

Shaft d ₁ d	d ₂	Bearings which fit the housing Unsplit bearings				Split spherical roller bearing	Required accessories																						
		Codes according to DIN*					FAG	Adapter sleeve	Locknut	Lock washer	Locating ring 2 pieces	Two-lip seal	Labyrinth ring with O ring FAG	Felt seal	Cover														
mm	inch	mm			FAG	FAG	FAG	FAG	FAG	FAG	FAG	FAG	FAG	FAG	FAG	FAG	FAG												
19.05	3/4		1305K	20305K		2305K	H305.012 H2305.012																						
20			1305K	20305K		2305K	H305 H2305																						
22.225	7/8		1206K	20206K		2206K 22206K	H206.014 H306.014																						
23.813	15/16		1206K	20206K		2206K 22206K	H206.015 H306.015																						
25			1206K	20206K		2206K 22206K	H206 H306																						
		30 30	6305	1305	20305	21305																							
25.4	1		1206K	20206K		2206K 22206K	H206.100 H306.100																						
30		35 35	6206	1206	20206	2206 22206																							

* The order designation in the code according to DIN can be taken from the catalogue WL 41520EA "FAG Rolling Bearings"

¹⁾ 100 mm at TSV206 and TSV305

FAG Plummer Block Housings, split

for bearings with cylindrical bore and
for bearings with tapered bore and adapter sleeve

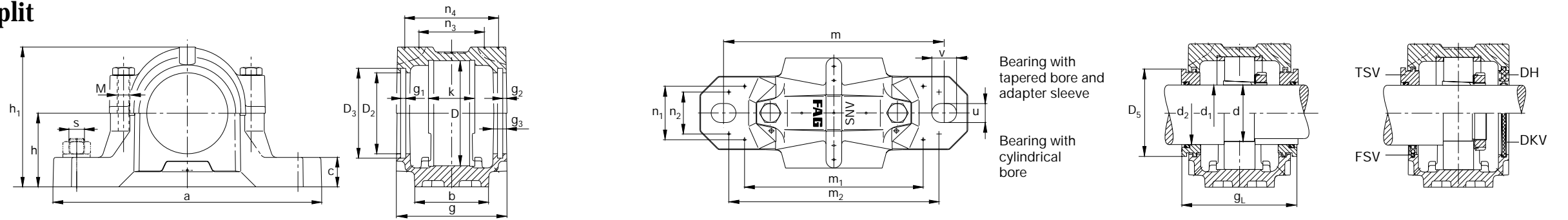

SNV072

Dimensions		b	c	g	h	m	s	u	v	h ₁	D ₂	D ₃	D ₅	g ₁	g ₂	g ₃	g _L	k	m ₁	n ₁	m ₂	n ₂	n ₃	n ₄	M DIN 931	M ₁ DIN 580	Mass ≈ kg	
D	a						mm inch	mm																				
72	185	52	22	80	50	150	M12 1/2	15	20	97	51.5	59.5	57.7	5	3	10.5	93 ¹⁾	33	115	37	135	25	46	66	M10	-	2	
Shaft d ₁ d																												
mm	inch																											
22.225	7/8							1306K	20306K																			
									2306K																			
23.813	15/16							1306K	20306K																			
									2306K																			
25								1306K	20306K																			
									2306K																			
25.4	1							1306K	20306K																			
									2306K																			
28.575	1 1/8							1207K	20207K																			
									2207K	22207K																		
30								1207K	20207K																			
									2207K	22207K																		
				35 35	6306	1306	20306	21306	2306																			
30.163	1 3/16							1207K	20207K																			
									2207K	22207K																		
35				45 45	6207	1207	20207		2207	22207																		

* The order designation in the code according to DIN can be taken from the catalogue WL 41520EA "FAG Rolling Bearings"

¹⁾ 105 mm at TSV207

FAG Plummer Block Housings, split

for bearings with cylindrical bore and
for bearings with tapered bore and adapter sleeve

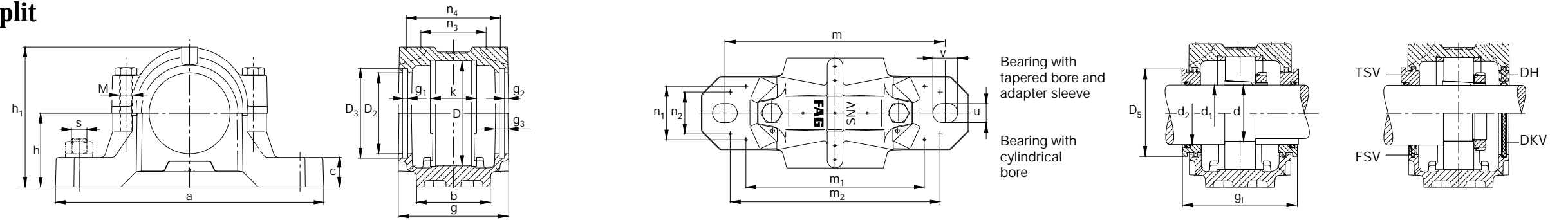

SNV080

Dimensions		b	c	g	h	m	s	u	v	h ₁	D ₂	D ₃	D ₅	g ₁	g ₂	g ₃	g _L	k	m ₁	n ₁	m ₂	n ₂	n ₃	n ₄	M DIN 931	M ₁ DIN 580	Mass ≈ kg
D	a						mm inch	mm																			
80	205	60	25	85	60	170	M12 1/2	15	20	112	62	70.5	68.7	5	3	10.5	98	39	135	43	160	34	52	71	M10	-	2.9

Shaft d ₁ d	d ₂	Bearings which fit the housing Unsplit bearings				Split spherical roller bearing FAG	Required accessories																				
		Codes according to DIN*					Adapter sleeve FAG	Locknut FAG	Lock washer FAG	Locating ring 2 pieces FAG	Two-lip seal FAG	Labyrinth ring with O ring FAG	Felt seal FAG	Cover FAG													
mm	inch	mm																									
28.575	1 ¹ / ₈		1307K	20307K	21307K	2307K							H307.102 H2307.102						FRM80/9 FRM80/4	DH607.102 DH607.102	TSV607.102 TSV607.102	FSV607.102 FSV607.102	DKV080 DKV080				
30			1307K	20307K	21307K	2307K							H307 H2307						FRM80/9 FRM80/4	DH607 DH607	TSV607 TSV607	FSV607 FSV607	DKV080 DKV080				
30.163	1 ³ / ₁₆		1307K	20307K	21307K	2307K							H307.103 H2307.103						FRM80/9 FRM80/4	DH607 DH607	TSV607 TSV607	FSV607 FSV607	DKV080 DKV080				
31.75	1 ¹ / ₄		1208K	20208K		2208K	22208K						H208.104 H308.104						FRM80/10,5 FRM80/8	DH508.104 DH508.104	TSV508.104 TSV508.104	FSV508.104 FSV508.104	DKV080 DKV080				
33.338	1 ⁵ / ₁₆		1208K	20208K		2208K	22208K						H208.105 H308.105						FRM80/10,5 FRM80/8	DH508.104 DH508.104	TSV508.105 TSV508.105	FSV508.105 FSV508.105	DKV080 DKV080				
34.925	1 ³ / ₈		1208K	20208K		2208K	22208K						H208.106 H308.106						FRM80/10,5 FRM80/8	DH508 DH508	TSV508 TSV508	FSV508 FSV508	DKV080 DKV080				
35			1208K	20208K		2208K	22208K						H208 H308						FRM80/10,5 FRM80/8 FRM80/9 FRM80/4	DH508 DH508 DH307 DH307	TSV508 TSV508 TSV307 TSV307	FSV508 FSV508 FSV307 FSV307	DKV080 DKV080 DKV080 DKV080				
40		45 45	6307	1307	20307	21307	2208K	22208K											FRM80/10,5 FRM80/8	DH208 DH208	TSV208 TSV208	FSV208 FSV208	DKV080 DKV080				

* The order designation in the code according to DIN can be taken from the catalogue WL 41520EA "FAG Rolling Bearings"

FAG Plummer Block Housings, split

for bearings with cylindrical bore and
for bearings with tapered bore and adapter sleeve

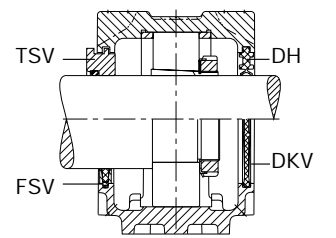
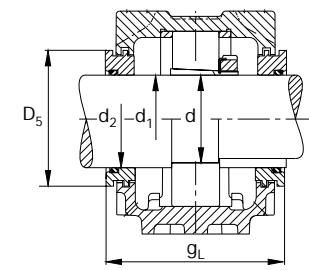
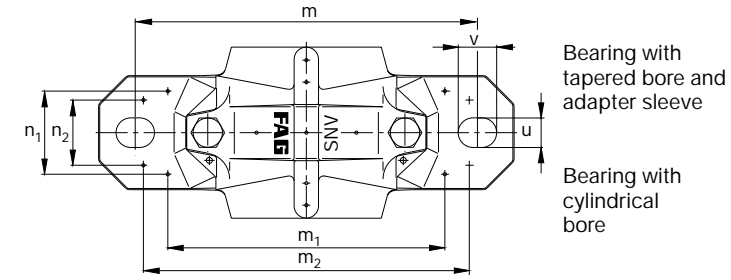
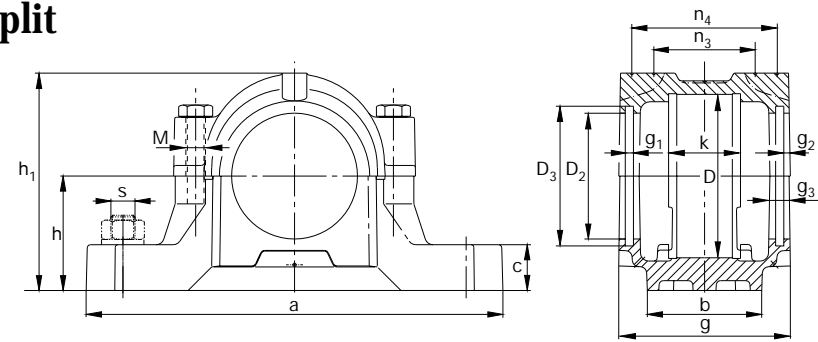

SNV085

Dimensions		b	c	g	h	m	s	u	v	h ₁	D ₂	D ₃	D ₅	g ₁	g ₂	g ₃	g _L	k	m ₁	n ₁	m ₂	n ₂	n ₃	n ₄	M DIN 931	M ₁ DIN 580	Mass ≈ kg
D	a						mm inch	mm																			
85	205	60	25	87	60	170	M12 1/2	15	20	114	67	75.5	73.7	5	4	12.5	101	31	135	40	160	34	47	71	M10	-	2.8

Shaft d ₁ d	d ₂	Bearings which fit the housing		Split spherical roller bearing	Required accessories										
		Unsplit bearings	Codes according to DIN*		FAG	Adapter sleeve	Locknut	Lock washer	Locating ring 2 pieces	Two-lip seal	Labyrinth ring with O ring FAG	Felt seal	Cover		
mm inch	mm			FAG	FAG	FAG	FAG	FAG	FAG	FAG	FAG	FAG	FAG	FAG	FAG
36.513	1⁷/₁₆		1209K 20209K		H209.107 H309.107			FRM85/6 FRM85/4		DH509.107 DH509.107		TSV509.107 TSV509.107		FSV509.107 FSV509.107	DKV085 DKV085
38.1	1¹/₂		1209K 20209K		H209.108 H309.108			FRM85/6 FRM85/4		DH509.107 DH509.107		TSV509.108 TSV509.108		FSV509.108 FSV509.108	DKV085 DKV085
40			1209K 20209K		H209 H309			FRM85/6 FRM85/4		DH509 DH509		TSV509 TSV509		FSV509 FSV509	DKV085 DKV085
45		55 55	6209 1209 20209												

* The order designation in the code according to DIN can be taken from the catalogue WL 41520EA "FAG Rolling Bearings"

FAG Plummer Block Housings, split

for bearings with cylindrical bore and
for bearings with tapered bore and adapter sleeve

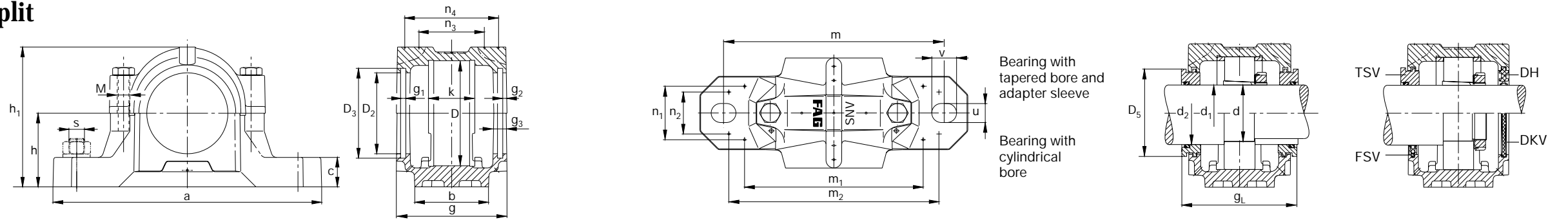

SNV090

Dimensions																						Mass						
D	a	b	c	g	h	m	s	u	v	h ₁	D ₂	D ₃	D ₅	g ₁	g ₂	g ₃	g _L	k	m ₁	n ₁	m ₂	n ₂	n ₃	n ₄	M DIN 931	M ₁ DIN 580	≈ kg	
mm							mm	inch	mm																			
90	205	60	25	100	60	170	M12	1/2	15	20	117	72	80.5	78.2	5	4	12.5	114	41	135	44	160	34	58	84	M10	-	3.1

Shaft d ₁ d	d ₂	Bearings which fit the housing Unsplit bearings						Split spherical roller bearing	Required accessories												
		Codes according to DIN*							FAG	Adapter sleeve	Locknut	Lock washer	Locating ring 2 pieces	Two-lip seal	Labyrinth ring with O ring FAG	Felt seal	Cover				
mm	inch	mm						FAG	FAG	FAG	FAG	FAG	FAG	FAG	FAG	FAG	FAG				
31.75	1 1/4		1308K	20308K	21308K	2308K	22208K		H308.104 H2308.104				FRM90/9 FRM90/4	DH608.104 DH608.104	TSV608.104 TSV608.104	FSV608.104 FSV608.104	DKV090 DKV090				
33.338	1 5/16		1308K	20308K	21308K	2308K	22308K		H308.105 H2308.105				FRM90/9 FRM90/4	DH608.104 DH608.104	TSV608.105 TSV608.105	FSV608.105 FSV608.105	DKV090 DKV090				
34.925	1 3/8		1308K	20308K	21308K	2308K	22308K		H308.106 H2308.106				FRM90/9 FRM90/4	DH608 DH608	TSV608 TSV608	FSV608 FSV608	DKV090 DKV090				
35			1308K	20308K	21308K	2308K	22308K		H308 H2308				FRM90/9 FRM90/4	DH608 DH608	TSV608 TSV608	FSV608 FSV608	DKV090 DKV090				
40		50 50	6308	1308	20308	21308	2308	22308						KM8 KM8	MB8A MB8A	FRM90/9 FRM90/4	DH308 DH308	TSV308 TSV308	FSV308 FSV308	DKV090 DKV090	
41.275	1 5/8			1210K	20210K		2210K	22210K						H210.110 H310.110		FRM90/10,5 FRM90/9	DH510.110 DH510.110	TSV510.110 TSV510.110	FSV510.110 FSV510.110	DKV090 DKV090	
42.863	1 11/16			1210K	20210K		2210K	22210K						H210.111 H310.111		FRM90/10,5 FRM90/9	DH510.110 DH510.110	TSV510.111 TSV510.111	FSV510.111 FSV510.111	DKV090 DKV090	
44.45	1 3/4			1210K	20210K		2210K	22210K						H210.112 H310.112		FRM90/10,5 FRM90/9	DH510 DH510	TSV510.112 TSV510.112	FSV510 FSV510	DKV090 DKV090	
45				1210K	20210K		2210K	22210K						H210 H310		FRM90/10,5 FRM90/9	DH510 DH510	TSV510 TSV510	FSV510 FSV510	DKV090 DKV090	
50		60 60	6210	1210	20210		2210	22210							KM10 KM10	MB10A MB10A	FRM90/10,5 FRM90/9	DH210 DH210	TSV210 TSV210	FSV210 FSV210	DKV090 DKV090

* The order designation in the code according to DIN can be taken from the catalogue WL 41520EA "FAG Rolling Bearings"

FAG Plummer Block Housings, split

for bearings with cylindrical bore and
for bearings with tapered bore and adapter sleeve

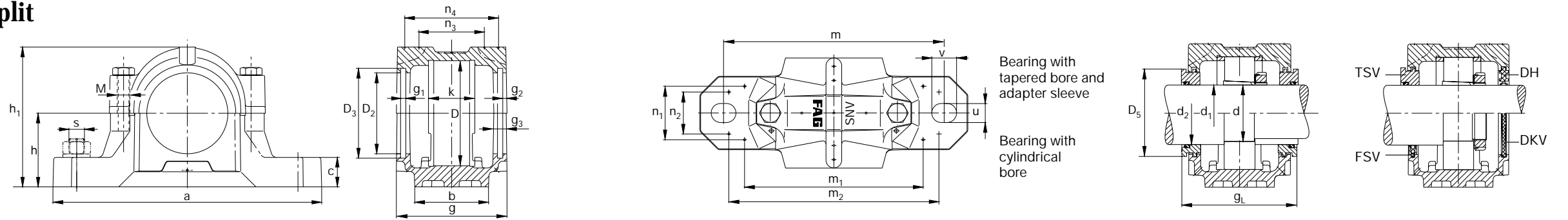

SNV100

Dimensions		b	c	g	h	m	s	u	v	h ₁	D ₂	D ₃	D ₅	g ₁	g ₂	g ₃	g _L	k	m ₁	n ₁	m ₂	n ₂	n ₃	n ₄	M DIN 931	M ₁ DIN 580	Mass ≈ kg
D	a						mm inch	mm	mm																		
100	255	70	28	105	70	210	M16 5/8	18	23	133	77	85.5	83.2	5	4	12.5	119	44	170	51	200	40	62	89	M12	-	4.3

Shaft d ₁ d	d ₂	Bearings which fit the housing Unsplit bearings						Split spherical roller bearing FAG	Required accessories										Cover FAG								
		Codes according to DIN*							Adapter sleeve FAG	Locknut FAG	Lock washer FAG	Locating ring 2 pieces FAG	Two-lip seal FAG	Labyrinth ring with O ring FAG	Felt seal FAG												
mm inch	mm																										
36.513	1 ⁷ / ₁₆					1309K	20309K	21309K	2309K	22309K			H309.107 H2309.107						FRM100/9,5 FRM100/4	DH609.107 DH609.107	TSV609.107 TSV609.107	FSV609.107 FSV609.107	DKV100 DKV100				
38.1	1 ¹ / ₂					1309K	20309K	21309K	2309K	22309K			H309.108 H2309.108						FRM100/9,5 FRM100/4	DH609.107 DH609.107	TSV609.108 TSV609.108	FSV609.108 FSV609.108	DKV100 DKV100				
39.688	1 ⁹ / ₁₆					1309K	20309K	21309K	2309K	22309K			H309.109 H2309.109						FRM100/9,5 FRM100/4	DH609 DH609	TSV609 TSV609	FSV609 FSV609	DKV100 DKV100				
40						1309K	20309K	21309K	2309K	22309K			H309 H2309						FRM100/9,5 FRM100/4	DH609 DH609	TSV609 TSV609	FSV609 FSV609	DKV100 DKV100				
45		55 55	6309	1309	20309	21309	2309	22309						KM9 KM9	MB9A MB9A				FRM100/9,5 FRM100/4	DH309 DH309	TSV309 TSV309	FSV309 FSV309	DKV100 DKV100				
47.625	1 ⁷ / ₈					1211K	20211K		2211K	22211K			H211.114 H311.114						FRM100/11,5 FRM100/9,5	DH511.114 DH511.114	TSV511.114 TSV511.114	FSV511.114 FSV511.114	DKV100 DKV100				
49.213	1 ¹⁵ / ₁₆					1211K	20211K		2211 K	22211K			H211.115 H311.115						FRM100/11,5 FRM100/9,5	DH511 DH511	TSV511.115 TSV511.115	FSV511.115 FSV511.115	DKV100 DKV100				
50						1211K	20211K		2211 K	22211K			H211 H311						FRM100/11,5 FRM100/9,5	DH511 DH511	TSV511 TSV511	FSV511 FSV511	DKV100 DKV100				
50.8	2					1211K	20211K		2211K	22211K			H211.200 H311.200						FRM100/11,5 FRM100/9,5	DH511 DH511	TSV511.200 TSV511.200	FSV511 FSV511	DKV100 DKV100				
55		65 65	6211	1211	20211		2211	22211						KM11 KM11	MB11A MB11A				FRM100/11,5 FRM100/9,5	DH211 DH211	TSV211 TSV211	FSV211 FSV211	DKV100 DKV100				

* The order designation in the code according to DIN can be taken from the catalogue WL 41520EA "FAG Rolling Bearings"

FAG Plummer Block Housings, split

for bearings with cylindrical bore and
for bearings with tapered bore and adapter sleeve

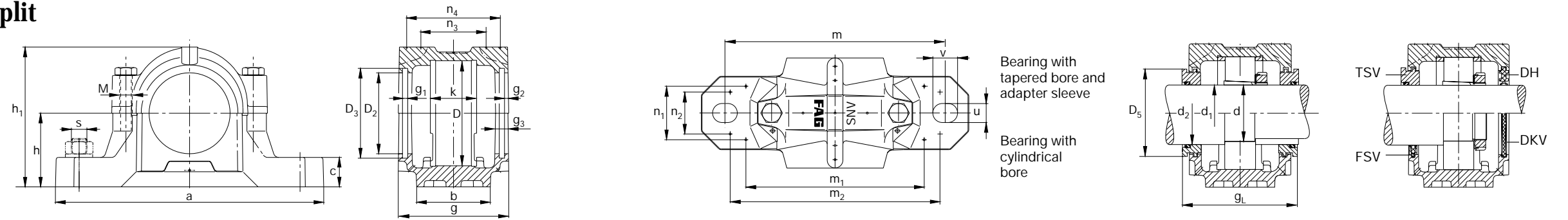

SNV110

Dimensions		b	c	g	h	m	s	u	v	h ₁	D ₂	D ₃	D ₅	g ₁	g ₂	g ₃	g _L	k	m ₁	n ₁	m ₂	n ₂	n ₃	n ₄	M DIN 931	M ₁ DIN 580	Mass ≈ kg
D	a						mm inch	mm	mm																		
110	255	70	30	110	70	210	M16 5/8	18	23	139	82	90.5	88.2	5	4	12.5	124	48	170	52	200	40	67	94	M12	-	4.9

Shaft d ₁ d	d ₂	Bearings which fit the housing Unsplit bearings						Split spherical roller bearing FAG	Required accessories																		
		Codes according to DIN*							Adapter sleeve FAG	Locknut FAG	Lock washer FAG	Locating ring 2 pieces FAG	Two-lip seal FAG	Labyrinth ring with O ring FAG	Felt seal FAG	Cover FAG											
mm inch	mm																										
41.275 1 ⁵ / ₈				1310K	20310K	21310K	2310K	22310K	H310.110 H2310.110				FRM110/10,5 FRM110/4	DH610.110 DH610.110	TSV610.110 TSV610.110	FSV610.110 FSV610.110	DKV110 DKV110										
42.863 1 ¹¹ / ₁₆				1310K	20310K	21310K	2310K	22310K	H310.111 H2310.111				FRM110/10,5 FRM110/4	DH610.110 DH610.110	TSV610.111 TSV610.111	FSV610.111 FSV610.111	DKV110 DKV110										
44.45 1 ³ / ₄				1310K	20310K	21310K	2310K	22310K	H310.112 H2310.112				FRM110/10,5 FRM110/4	DH610 DH610	TSV610.112 TSV610.112	FSV610 FSV610	DKV110 DKV110										
45				1310K	20310K	21310K	2310K	22310K	H310 H2310				FRM110/10,5 FRM110/4	DH610 DH610	TSV610 TSV610	FSV610 FSV610	DKV110 DKV110										
50		60 60	6310	1310	20310	21310	2310	22310						KM10 KM10	MB10A MB10A	FRM110/10,5 FRM110/4	DH310 DH310	TSV310 TSV310	FSV310 FSV310	DKV110 DKV110							
53.975 2 ¹ / ₈				1212K	20212K		2212K	22212K	H212.202 H312.202				FRM110/13 FRM110/10	DH512 DH512	TSV512.202 TSV512.202	FSV512.202 FSV512.202	DKV110 DKV110										
55				1212K	20212K		2212K	22212K	H212 H312			222SM55T	FRM110/13 FRM110/10 FRM110/10	DH512 DH512 DH512	TSV512 TSV512 TSV512	FSV512 FSV512 FSV512	DKV110 DKV110 DKV110										
60		70 70	6212	1212	20212		2212	22212						KM12 KM12	MB12A MB12A	FRM110/13 FRM110/10	DH212 DH212	TSV212 TSV212	FSV212 FSV212	DKV110 DKV110							

* The order designation in the code according to DIN can be taken from the catalogue WL 41520EA "FAG Rolling Bearings"

FAG Plummer Block Housings, split

for bearings with cylindrical bore and
for bearings with tapered bore and adapter sleeve

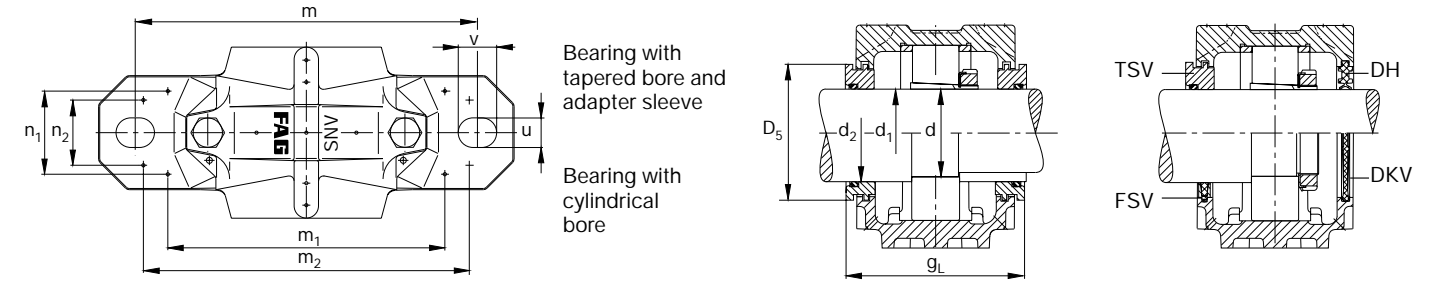
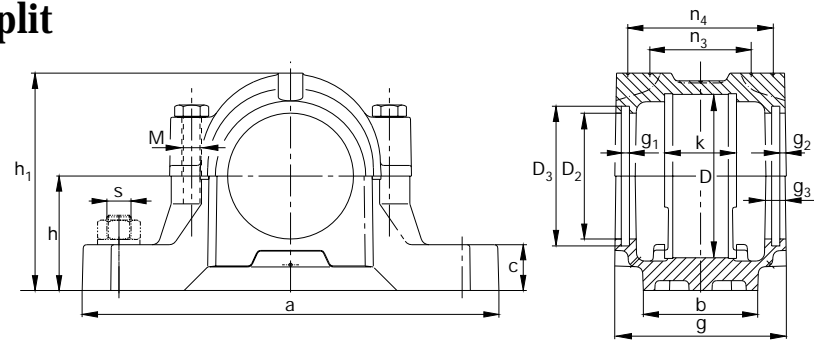

Bearing with tapered bore and adapter sleeve
Bearing with cylindrical bore

SNV120

Dimensions		b	c	g	h	m	s	u	v	h ₁	D ₂	D ₃	D ₅	g ₁	g ₂	g ₃	g _L	k	m ₁	n ₁	m ₂	n ₂	n ₃	n ₄	M DIN 931	M ₁ DIN 580	Mass ≈ kg
D	a						mm inch	mm	mm	mm	mm	mm	mm	mm	mm	mm	mm	mm	mm	mm	mm	mm	mm	mm			
120	275	80	30	115	80	230	M16 5/8	18	23	155	87	95.5	93.2	5	4	12.5	129	51	190	58	220	48	71	99	M12	-	6.1
Shaft d ₁ d		d ₂	Bearings which fit the housing Unsplit bearings					Split spherical roller bearing		Required accessories																	
mm	inch	mm	Codes according to DIN*					FAG		Adapter sleeve	Locknut	Lock washer	Locating ring 2 pieces	Two-lip seal	Labyrinth ring with O ring FAG	Felt seal	Cover										
										FAG	FAG	FAG	FAG	FAG	FAG	FAG	FAG										
47.625	1 ⁷ / ₈		1311K	20311K	21311K	2311K	22311K			H311.114 H2311.114			FRM120/11 FRM120/4	DH611.114 DH611.114	TSV611.114 TSV611.114	FSV611.114 FSV611.114	DKV120 DKV120										
49.213	1 ¹⁵ / ₁₆		1311K	20311K	21311K	2311K	22311K			H311.115 H2311.115			FRM120/11 FRM120/4	DH611 DH611	TSV611.115 TSV611.115	FSV611.115 FSV611.115	DKV120 DKV120										
50			1311K	20311K	21311K	2311K	22311K			H311 H2311			FRM120/11 FRM120/4	DH611 DH611	TSV611 TSV611	FSV611 FSV611	DKV120 DKV120										
50.8	2		1311K	20311K	21311K	2311K	22311K			H311.200 H2311.200			FRM120/11 FRM120/4	DH611 DH611	TSV611.200 TSV611.200	FSV611 FSV611	DKV120 DKV120										
55		65 65	6311	1311	20311	21311	2311	22311						KM11 KM11	MB11A MB11A	FRM120/11 FRM120/4	DH311 DH311	TSV311 TSV311	FSV311 FSV311	DKV120 DKV120							
55.563	2 ³ / ₁₆		1213K	20213K		2213K	22213K			H213.203 H313.203		222S.203	FRM120/14 FRM120/10 FRM120/10	DH513.203 DH513.203 DH513.203	TSV513.203 TSV513.203 TSV513.203	FSV513.203 FSV513.203 FSV513.203	DKV120 DKV120 DKV120										
57.15	2 ¹ / ₄		1213K	20213K		2213K	22213K			H213.204 H313.204		222S.204	FRM120/14 FRM120/10 FRM120/10	DH513.203 DH513.203 DH513.203	TSV513.204 TSV513.204 TSV513.204	FSV513.204 FSV513.204 FSV513.204	DKV120 DKV120 DKV120										
60			1213K	20213K		2213K	22213K			H213 H313			FRM120/14 FRM120/10	DH513 DH513	TSV513 TSV513	FSV513 FSV513	DKV120 DKV120										
60.325	2 ³ / ₈		1213K	20213K		2213K	22213K			H213.206 H313.206			FRM120/14 FRM120/10	DH513 DH513	TSV513 TSV513	FSV513 FSV513	DKV120 DKV120										
65		75 75	6213	1213	20213	2213	22213							KM13 KM13	MB13A MB13A	FRM120/14 FRM120/10	DH213 DH213	TSV213 TSV213	FSV213 FSV213	DKV120 DKV120							

* The order designation in the code according to DIN can be taken from the catalogue WL 41520EA "FAG Rolling Bearings"

FAG Plummer Block Housings, split

for bearings with cylindrical bore and
for bearings with tapered bore and adapter sleeve

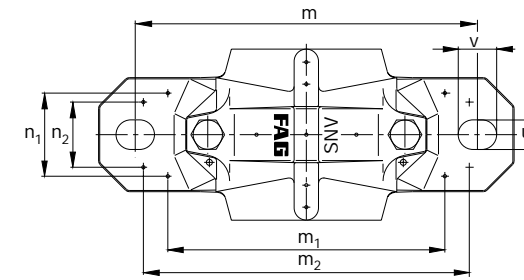
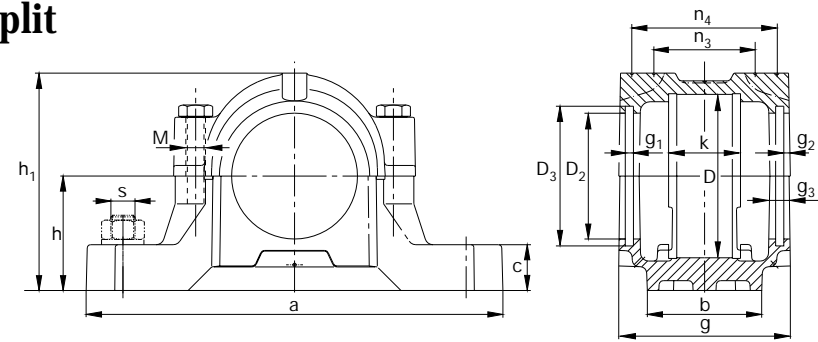

Bearing with tapered bore and adapter sleeve
Bearing with cylindrical bore

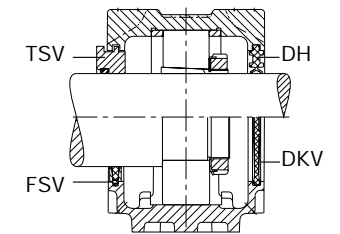
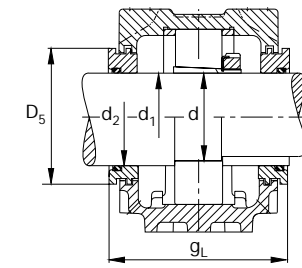

SNV125

Dimensions		b	c	g	h	m	s	u	v	h ₁	D ₂	D ₃	D ₅	g ₁	g ₂	g ₃	g _L	k	m ₁	n ₁	m ₂	n ₂	n ₃	n ₄	M DIN 931	M ₁ DIN 580	Mass ≈ kg	
D	a						mm inch	mm																				
125	275	80	30	105	80	230	M16 5/8	18	23	158	112	120.5	118.2	5	5.25	15	120.3	39	190	52	220	48	57	86	M12	-	6.5	
Shaft d ₁ d		d ₂	Bearings which fit the housing Unsplit bearings				Split spherical roller bearing		Required accessories																			
mm	inch	mm	Codes according to DIN*				FAG		Adapter sleeve	Locknut	Lock washer	Locating ring 2 pieces	Two-lip seal	Labyrinth ring with O ring FAG	Felt seal	Cover												
70		80 80	6214	1214	20214				2214	22214																		

* The order designation in the code according to DIN can be taken from the catalogue WL 41520EA "FAG Rolling Bearings"

FAG Plummer Block Housings, split

for bearings with cylindrical bore and
for bearings with tapered bore and adapter sleeve

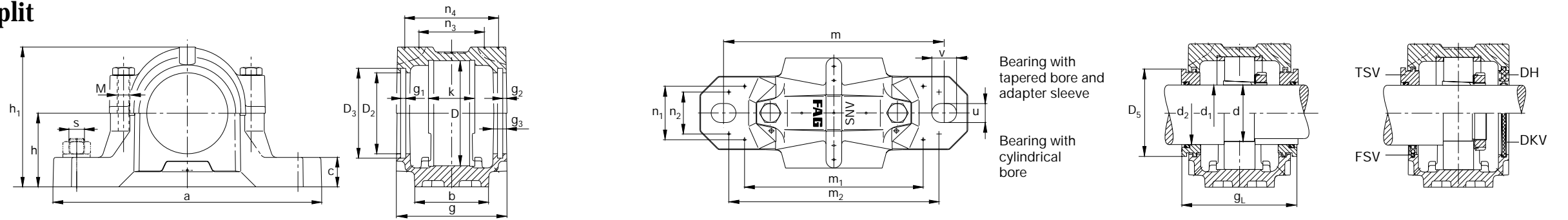

SNV130

Dimensions		b	c	g	h	m	s	u	v	h ₁	D ₂	D ₃	D ₅	g ₁	g ₂	g ₃	g _L	k	m ₁	n ₁	m ₂	n ₂	n ₃	n ₄	M DIN 931	M ₁ DIN 580	Mass ≈ kg
D	a						mm inch	mm																			
130	280	80	30	120	80	230	M16 5/8	18	23	161	102.5	111	108.7	5	4	12.5	134	56	190	60	220	48	76	104	M12	-	6.8

Shaft d ₁ d	d ₂	Bearings which fit the housing Unsplit bearings						Split spherical roller bearing FAG	Required accessories									
		Codes according to DIN*							Adapter sleeve	Locknut	Lock washer	Locating ring 2 pieces	Two-lip seal	Labyrinth ring with O ring FAG	Felt seal	Cover		
mm inch	mm								FAG	FAG	FAG	FAG	FAG	FAG	FAG	FAG		
53.975 2 ¹ / ₈		1312K	20312K	21312K	2312K	22312K		H312.202 H2312.202				FRM130/12,5 FRM130/5	DH612 DH612	TSV612.202 TSV612.202	FSV612.202 FSV612.202	DKV130 DKV130		
55		1312K	20312K	21312K	2312K	22312K		H312 H2312				FRM130/12,5 FRM130/5	DH612 DH612	TSV612 TSV612	FSV612 FSV612	DKV130 DKV130		
60	70 70	6312	1312	20312	21312	2312	22312					FRM130/12,5 FRM130/5	DH312 DH312	TSV312 TSV312	FSV312 FSV312	DKV130 DKV130		
61.913 2 ⁷ / ₁₆		1215K	20215K		2215K	22215K		H215.207 H315.207				FRM130/15,5 FRM130/12,5 FRM130/12,5	DH515.207 DH515.207 DH515.207	TSV515.207 TSV515.207 TSV515.207	FSV515.207 FSV515.207 FSV515.207	DKV130 DKV130 DKV130		
63.5 2 ¹ / ₂		1215K	20215K		2215K	22215K		H215.208 H315.208				FRM130/15,5 FRM130/12,5 FRM130/12,5	DH515.207 DH515.207 DH515.207	TSV515.208 TSV515.208 TSV515.208	FSV515.208 FSV515.208 FSV515.208	DKV130 DKV130 DKV130		
65		1215K	20215K		2215K	22215K		H215 H315				FRM130/15,5 FRM130/12,5 FRM130/12,5	DH515 DH515 DH515	TSV515 TSV515 TSV515	FSV515 FSV515 FSV515	DKV130 DKV130 DKV130		
66.675 2 ⁵ / ₈		1215K	20215K		2215K	22215K		H215.210 H315.210				FRM130/15,5 FRM130/12,5	DH515 DH515	TSV515.210 TSV515.210	FSV515.210 FSV515.210	DKV130 DKV130		
75	85 85	6215	1215	20215	2215	22215						FRM130/15,5 FRM130/12,5	DH215 DH215	TSV215 TSV215	FSV215 FSV215	DKV130 DKV130		

* The order designation in the code according to DIN can be taken from the catalogue WL 41520EA "FAG Rolling Bearings"

FAG Plummer Block Housings, split

for bearings with cylindrical bore and
for bearings with tapered bore and adapter sleeve

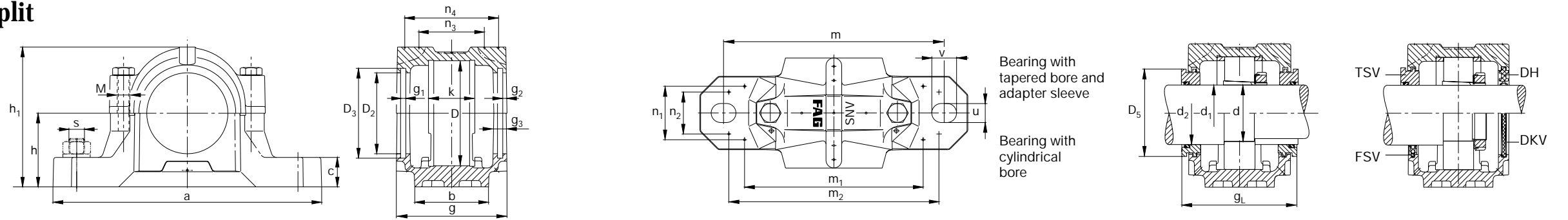

SNV140

Dimensions		b	c	g	h	m	s	u	v	h ₁	D ₂	D ₃	D ₅	g ₁	g ₂	g ₃	g _L	k	m ₁	n ₁	m ₂	n ₂	n ₃	n ₄	M DIN 931	M ₁ DIN 580	Mass ≈ kg
D	a						mm inch	mm	mm	mm	mm	mm	mm	mm	mm	mm	mm	mm	mm	mm	mm	mm	mm	mm			
140	315	90	32	135	95	260	M20 3/4	22	27	183	108	116.5	114.2	5	5.25	15	150.3	58	210	65	252	52	81	117	M12	-	9.3

Shaft d ₁ d	d ₂	Bearings which fit the housing Unsplit bearings						Split spherical roller bearing FAG	Required accessories																		
		Codes according to DIN*							Adapter sleeve FAG	Locknut FAG	Lock washer FAG	Locating ring 2 pieces FAG	Two-lip seal FAG	Labyrinth ring with O ring FAG	Felt seal FAG	Cover FAG											
mm inch	mm																										
55.563	2 ³ / ₁₆						1313K 20313K 21313K	2313K 22313K	H313.203 H2313.203				FRM140/12,5 FRM140/5	DH613.203 DH613.203	TSV613.203 TSV613.203	FSV613.203 FSV613.203	DKV140 DKV140										
57.15	2 ¹ / ₄						1313K 20313K 21313K	2313K 22313K	H313.204 H2313.204				FRM140/12,5 FRM140/5	DH613.203 DH613.203	TSV613.204 TSV613.204	FSV613.204 FSV613.204	DKV140 DKV140										
60							1313K 20313K 21313K	2313K 22313K	H313 H2313				FRM140/12,5 FRM140/5	DH613 DH613	TSV613 TSV613	FSV613 FSV613	DKV140 DKV140										
60.325	2 ³ / ₈						1313K 20313K 21313K	2313K 22313K	H313.206 H2313.206				FRM140/12,5 FRM140/5	DH613 DH613	TSV613 TSV613	FSV613 FSV613	DKV140 DKV140										
65		75 75	6313	1313	20313	21313		2313 22313						KM13 KM13	MB13A MB13A	FRM140/12,5 FRM140/5	DH313 DH313	TSV313 TSV313	FSV313 FSV313	DKV140 DKV140							
68.263	2 ¹¹ / ₁₆						1216K 20216K	2216K 22216K	H216.211 H316.211			222S.211					FRM140/16 FRM140/12,5 FRM140/12,5	DH516.211 DH516.211 DH516.211	TSV516.211 TSV516.211 TSV516.211	FSV516.211 FSV516.211 FSV516.211	DKV140 DKV140 DKV140						
69.85	2 ³ / ₄						1216K 20216K	2216K 22216K	H216.212 H316.212								FRM140/16 FRM140/12,5	DH516 DH516	TSV516 TSV516	FSV516 FSV516	DKV140 DKV140						
70							1216K 20216K	2216K 22216K	H216 H316								FRM140/16 FRM140/12,5 FRM140/12,5	DH516 DH516 DH516	TSV516 TSV516 TSV516	FSV516 FSV516 FSV516	DKV140 DKV140 DKV140						
73.025	2 ⁷ / ₈						1216K 20216K	2216K 22216K	H216.214 H316.214								FRM140/16 FRM140/12,5	DH516.214 DH516.214	TSV516.214 TSV516.214	FSV516.214 FSV516.214	DKV140 DKV140						
80		90 90	6216	1216	20216			2216 22216										KM16 KM16	MB16A MB16A	FRM140/16 FRM140/12,5	DH216 DH216	TSV216 TSV216	FSV216 FSV216	DKV140 DKV140			

* The order designation in the code according to DIN can be taken from the catalogue WL 41520EA "FAG Rolling Bearings"

FAG Plummer Block Housings, split

for bearings with cylindrical bore and
for bearings with tapered bore and adapter sleeve

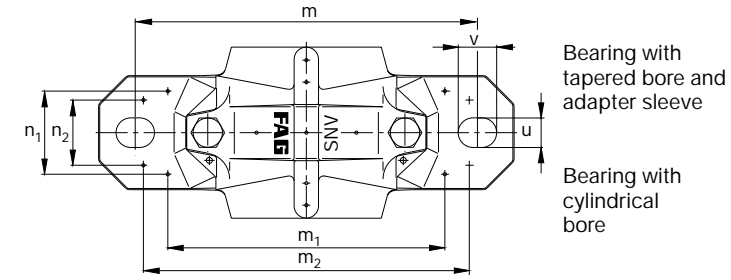
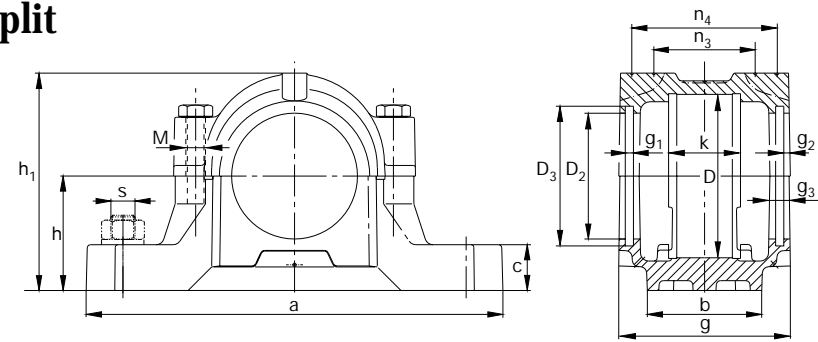

Bearing with tapered bore and adapter sleeve
Bearing with cylindrical bore

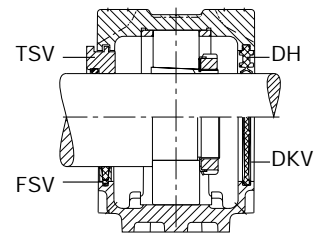
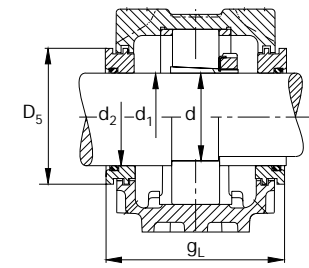

SNV150

Dimensions		b	c	g	h	m	s	u	v	h ₁	D ₂	D ₃	D ₅	g ₁	g ₂	g ₃	g _L	k	m ₁	n ₁	m ₂	n ₂	n ₃	n ₄	M DIN 931	M ₁ DIN 580	Mass ≈ kg	
D	a						mm inch	mm																				
150	320	90	32	140	95	260	M20 3/4	22	27	189	112	120.5	118.2	5	5.25	15	155.3	61	210	66	252	52	85	122	M12	-	9.9	
Shaft d ₁ d																												
mm	inch																											
70																												
74.613	2¹⁵/₁₆																											
75																												
76.2	3																											
85																												

* The order designation in the code according to DIN can be taken from the catalogue WL 41520EA "FAG Rolling Bearings"

FAG Plummer Block Housings, split

for bearings with cylindrical bore and
for bearings with tapered bore and adapter sleeve

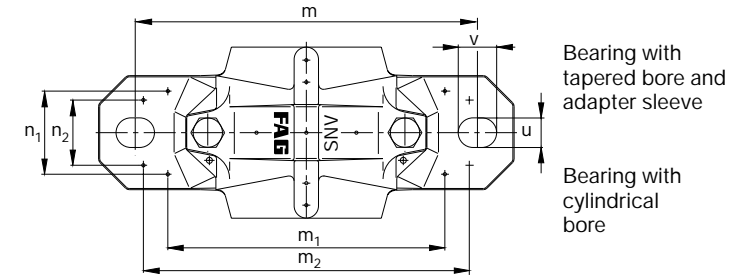
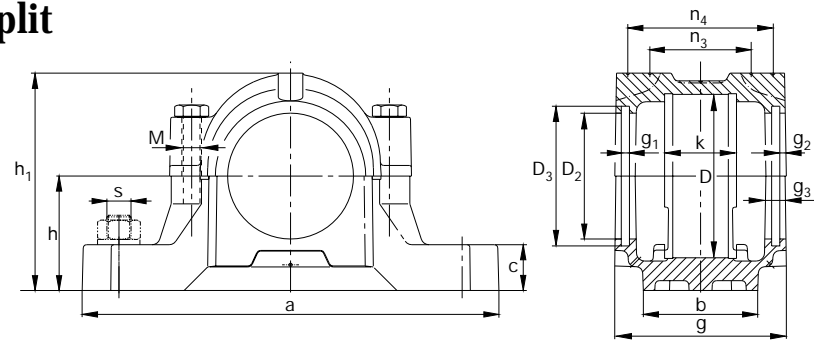

Bearing with tapered bore and adapter sleeve
Bearing with cylindrical bore

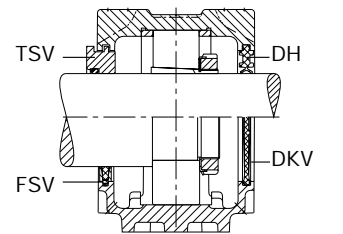
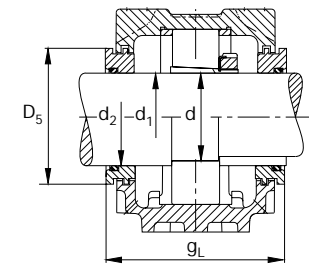

SNV160

Dimensions		b	c	g	h	m	s	u	v	h ₁	D ₂	D ₃	D ₅	g ₁	g ₂	g ₃	g _L	k	m ₁	n ₁	m ₂	n ₂	n ₃	n ₄	M DIN 931	M ₁ DIN 580	Mass ≈ kg
D	a						mm inch	mm																			
160	345	100	35	145	100	290	M20 3/4	22	27	201	120	128.5	125.7	5	5.25	15	160.3	65	240	72	280	58	90	127	M16	-	12.8
Shaft d ₁ d		d ₂		Bearings which fit the housing Unsplit bearings				Split spherical roller bearing		Required accessories																	
mm inch		mm		Codes according to DIN*				FAG		FAG		FAG		FAG		FAG		FAG		FAG		FAG		FAG		FAG	
61.913	2 ⁷ / ₁₆						1315K 20315K 21315K	2315K	22315K				H315.207 H2315.207				160.3	65	FRM160/14 FRM160/5	72	280	58	90	127	M16	-	12.8
63.5	2 ¹ / ₂						1315K 20315K 21315K	2315K	22315K				H315.208 H2315.208				160.3	65	FRM160/14 FRM160/5	72	280	58	90	127	M16	-	12.8
65							1315K 20315K 21315K	2315K	22315K				H315 H2315				160.3	65	FRM160/14 FRM160/5	72	280	58	90	127	M16	-	12.8
66.675	2 ⁵ / ₈						1315K 20315K 21315K	2315K	22315K				H315.210 H2315.210				160.3	65	FRM160/14 FRM160/5	72	280	58	90	127	M16	-	12.8
75		85 85	6315	1315	20315	21315		2315	22315					KM15 KM15	MB15A MB15A		160.3	65	FRM160/14 FRM160/5	72	280	58	90	127	M16	-	12.8
79.375	3 ¹ / ₈						1218K 20218K	2218K	22218K			23218K	H218.302 H318.302 H2318.302				160.3	65	FRM160/17,5 FRM160/12,5 FRM160/6,3	72	280	58	90	127	M16	-	12.8
80							1218K 20218K	2218K	22218K			23218K	H218 H318 H2318				160.3	65	FRM160/17,5 FRM160/12,5 FRM160/12,5 FRM160/6,3	72	280	58	90	127	M16	-	12.8
80.963	3 ³ / ₁₆						1218K 20218K	2218K	22218K			23218K	H218.303 H318.303 H2318.303				160.3	65	FRM160/17,5 FRM160/12,5 FRM160/12,5 FRM160/6,3	72	280	58	90	127	M16	-	12.8
82.55	3 ¹ / ₄						1218K 20218K	2218K	22218K			23218K	H218.304 H318.304 H2318.304				160.3	65	FRM160/17,5 FRM160/12,5 FRM160/12,5 FRM160/6,3	72	280	58	90	127	M16	-	12.8
90		100 100 100	6218	1218	20218			2218	22218			23218		KM18 KM18 KM18	MB18A MB18A MB18A		160.3	65	FRM160/17,5 FRM160/12,5 FRM160/6,3	72	280	58	90	127	M16	-	12.8

* The order designation in the code according to DIN can be taken from the catalogue WL 41520EA "FAG Rolling Bearings"

FAG Plummer Block Housings, split

for bearings with cylindrical bore and
for bearings with tapered bore and adapter sleeve

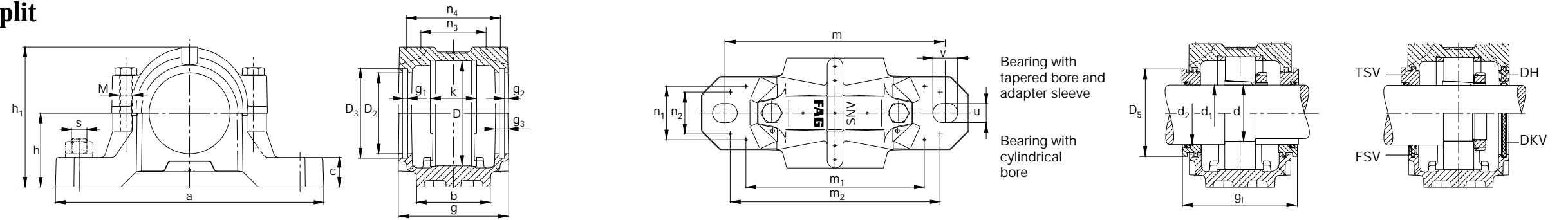

SNV170

Dimensions																						Mass					
D	a	b	c	g	h	m	s	u	v	h ₁	D ₂	D ₃	D ₅	g ₁	g ₂	g ₃	g _L	k	m ₁	n ₁	m ₂	n ₂	n ₃	n ₄	M DIN 931	M ₁ DIN 580	≈ kg
mm							mm inch	mm																			
170	345	100	35	150	112	290	M20 3/4	22	27	219	131	141	138.2	6	5.25	16	167.3	68	240	74	280	58	93	132	M16	-	14.4

Shaft d ₁ d	d ₂	Bearings which fit the housing Unsplit bearings						Split spherical roller bearing FAG	Required accessories																	
		Codes according to DIN*							Adapter sleeve FAG	Locknut FAG	Lock washer FAG	Locating ring 2 pieces FAG	Two-lip seal FAG	Labyrinth ring with O ring FAG	Felt seal FAG	Cover FAG										
mm	inch	mm																								
68.263	2 ¹¹ / ₁₆		1316K	20316K	21316K	2316K	22316K		H316.211 H2316.211				FRM170/14,5 FRM170/5	DH616.211 DH616.211	TSV616.211 TSV616.211	FSV616.211 FSV616.211	DKV170 DKV170									
69.85	2 ³ / ₄		1316K	20316K	21316K	2316K	22316K		H316.212 H2316.212				FRM170/14,5 FRM170/5	DH616 DH616	TSV616 TSV616	FSV616 FSV616	DKV170 DKV170									
70			1316K	20316K	21316K	2316K	22316K		H316 H2316				FRM170/14,5 FRM170/5	DH616 DH616	TSV616 TSV616	FSV616 FSV616	DKV170 DKV170									
73.025	2 ⁷ / ₈		1316K	20316K	21316K	2316K	22316K		H316.214 H2316.214				FRM170/14,5 FRM170/5	DH616.214 DH616.214	TSV616.214 TSV616.214	FSV616.214 FSV616.214	DKV170 DKV170									
80		90 90	6316	1316	20316	21316	2316	22316						KM16 KM16	MB16A MB16A	FRM170/14,5 FRM170/5	DH316 DH316	TSV316 TSV316	FSV316 FSV316	DKV170 DKV170						
85			1219K	20219K		2219K	22219K		H219 H319		222SM85T					FRM170/18 FRM170/12,5 FRM170/12,5	DH519 DH519 DH519	TSV519 TSV519 TSV519	FSV519 FSV519 FSV519	DKV170 DKV170 DKV170						
85.725	3 ³ / ₈		1219K	20219K		2219K	22219K		H219.306 H319.306							FRM170/18 FRM170/12,5	DH519 DH519	TSV519.306 TSV519.306	FSV519 FSV519	DKV170 DKV170						
95		110 110	6219	1219	20219	2219	22219							KM19 KM19	MB19A MB19A	FRM170/18 FRM170/12,5	DH219 DH219	TSV219 TSV219	FSV219 FSV219	DKV170 DKV170						

* The order designation in the code according to DIN can be taken from the catalogue WL 41520EA "FAG Rolling Bearings"

FAG Plummer Block Housings, split

for bearings with cylindrical bore and
for bearings with tapered bore and adapter sleeve

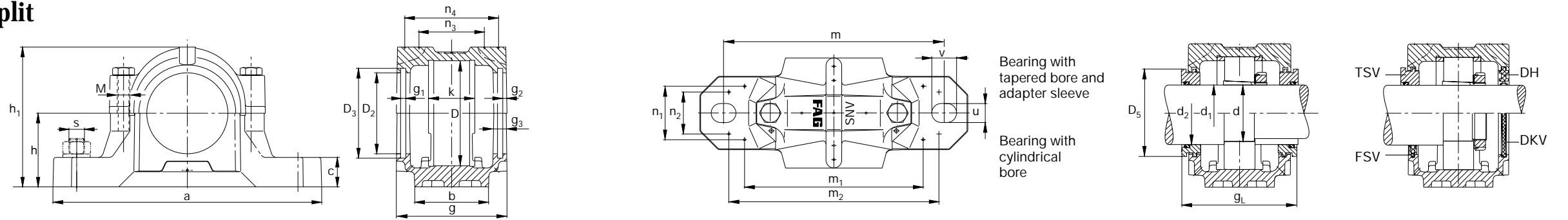

SNV180

Dimensions		b	c	g	h	m	s	u	v	h ₁	D ₂	D ₃	D ₅	g ₁	g ₂	g ₃	g _L	k	m ₁	n ₁	m ₂	n ₂	n ₃	n ₄	M DIN 931	M ₁ DIN 580	Mass ≈ kg			
D	a						mm inch	mm																						
180	380	110	40	160	112	320	M24 7/8	26	32	223	137.5	147.5	144.7	6	5.25	16	177.3	70	261	80	300	66	99	142	M20	-	17			
Shaft d ₁ d			d ₂	Bearings which fit the housing Unsplit bearings				Split spherical roller bearing		Required accessories																				
mm	inch	mm		Codes according to DIN*				FAG		FAG	Adapter sleeve	Locknut	Lock washer	Locating ring 2 pieces	Two-lip seal	Labyrinth ring with O ring FAG	Felt seal	Cover												
74.613	2 ¹⁵ / ₁₆			1317K	20317K	21317K		2317K	22317K				H317.215 H2317.215						FRM180/14,5 FRM180/5	DH617 DH617	TSV617 TSV617	FSV617 FSV617								
75				1317K	20317K	21317K		2317K	22317K				H317 H2317						FRM180/14,5 FRM180/5	DH617 DH617	TSV617 TSV617	FSV617 FSV617								
76.2	3			1317K	20317K	21317K		2317K	22317K				H317.300 H2317.300						FRM180/14,5 FRM180/5	DH617 DH617	TSV617.300 TSV617.300	FSV617.300 FSV617.300								
85		95 95	6317	1317	20317	21317		2317	22317					KM17 KM17	MB17A MB17A				FRM180/14,5 FRM180/5	DH317 DH317	TSV317 TSV317	FSV317 FSV317								
87.313	3 ⁷ / ₁₆			1220K	20220K			2220K	2220K			23220K	H220.307 H320.307						FRM180/18 FRM180/12 FRM180/12 FRM180/4,85	DH520.307 DH520.307 DH520.307 DH520.307	TSV520.307 TSV520.307 TSV520.307 TSV520.307	FSV520.307 FSV520.307 FSV520.307 FSV520.307								
88.9	3 ¹ / ₂			1220K	20220K			2220K	2220K			23220K	H220.308 H320.308						FRM180/18 FRM180/12 FRM180/12 FRM180/4,85	DH520 DH520 DH520 DH520	TSV520.308 TSV520.308 TSV520.308 TSV520.308	FSV520.308 FSV520.308 FSV520.308 FSV520.308								
90				1220K	20220K			2220K	2220K			23220K	H220 H320						FRM180/18 FRM180/12 FRM180/12 FRM180/4,85	DH520 DH520 DH520 DH520	TSV520 TSV520 TSV520 TSV520	FSV520 FSV520 FSV520 FSV520								
92.075	3 ⁵ / ₈			1220K	20220K			2220K	2220K			23220K	H220.310 H320.310 H2320.310						FRM180/18 FRM180/12 FRM180/4,85	DH520.310 DH520.310 DH520.310	TSV520.310 TSV520.310 TSV520.310	FSV520.310 FSV520.310 FSV520.310								
93.663	3 ¹¹ / ₁₆			1220K	20220K			2220K	2220K			23220K	H220.311 H320.311 H2320.311						FRM180/18 FRM180/12 FRM180/4,85	DH520.310 DH520.310 DH520.310	TSV520.311 TSV520.311 TSV520.311	FSV520.311 FSV520.311 FSV520.311								
100		115 115 115	6220	1220	20220			2220	2220			23220		KM20 KM20 KM20	MB20A MB20A MB20A				FRM180/18 FRM180/12 FRM180/4,85	DH220 DH220 DH220	TSV220 TSV220 TSV220	FSV220 FSV220 FSV220								

* The order designation in the code according to DIN can be taken from the catalogue WL 41520EA "FAG Rolling Bearings"

FAG Plummer Block Housings, split

for bearings with cylindrical bore and
for bearings with tapered bore and adapter sleeve

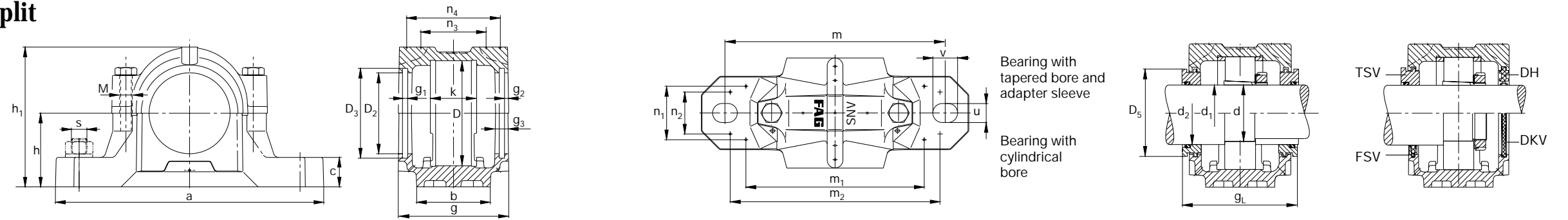

SNV190

Dimensions		b	c	g	h	m	s	u	v	h ₁	D ₂	D ₃	D ₅	g ₁	g ₂	g ₃	g _L	k	m ₁	n ₁	m ₂	n ₂	n ₃	n ₄	M DIN 931	M ₁ DIN 580	Mass ≈ kg	
D	a						mm	inch	mm																			
190	380	110	40	155	112	320	M24	7/8	26	32	229	120	128.5	125.7	5	5.25	15	170.3	74	271	81	300	66	99	137	M20	-	22

Shaft d ₁ d	d ₂	Bearings which fit the housing		Split spherical roller bearing	Required accessories											
		Unsplit bearings	Codes according to DIN*		FAG	Adapter sleeve	Locknut	Lock washer	Locating ring 2 pieces	Two-lip seal	Labyrinth ring with O ring FAG	Felt seal	Cover			
mm	inch	mm		FAG	FAG	FAG	FAG	FAG	FAG	FAG	FAG	FAG	FAG	FAG	FAG	FAG
79.375	3 ¹ / ₈		1318K 20318K 21318K	2318K 22318K	H318.302 H2318.302			FRM190/15,5 FRM190/5	DH518 DH518	TSV518.302 TSV518.302	FSV518 FSV518	DKV160 DKV160				
80			1318K 20318K 21318K	2318K 22318K	H318 H2318			FRM190/15,5 FRM190/5	DH518 DH518	TSV518 TSV518	FSV518 FSV518	DKV160 DKV160				
80.963	3 ³ / ₁₆		1318K 20318K 21318K	2318K 22318K	H318.303 H2318.303			FRM190/15,5 FRM190/5	DH518 DH518	TSV518.303 TSV518.303	FSV518.303 FSV518.303	DKV160 DKV160				
82.55	3 ¹ / ₄		1318K 20318K 21318K	2318K 22318K	H318.304 H2318.304			FRM190/15,5 FRM190/5	DH518.304 DH518.304	TSV518.304 TSV518.304	FSV518.304 FSV518.304	DKV160 DKV160				
90		105 105	6318 1318 20318 21318	2318 22318												

* The order designation in the code according to DIN can be taken from the catalogue WL 41520EA "FAG Rolling Bearings"

FAG Plummer Block Housings, split

for bearings with cylindrical bore and
for bearings with tapered bore and adapter sleeve

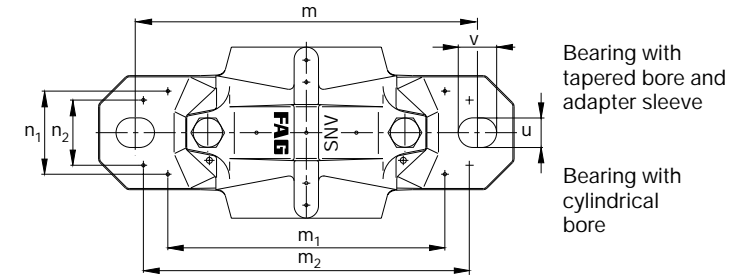
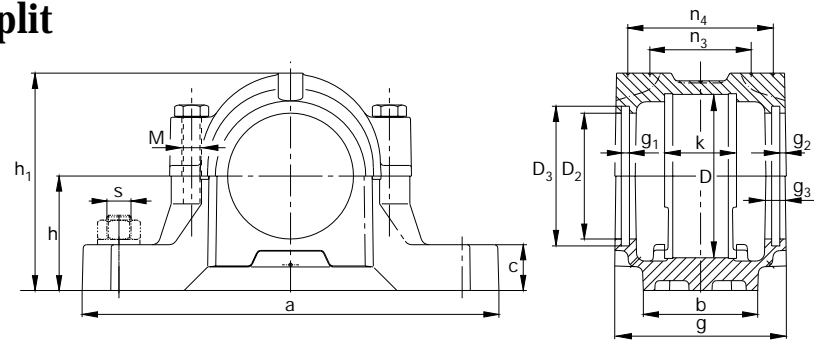

Bearing with tapered bore and adapter sleeve
Bearing with cylindrical bore

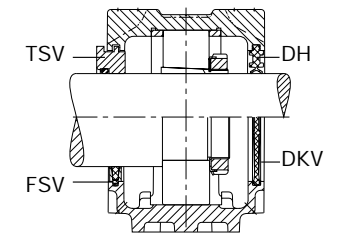
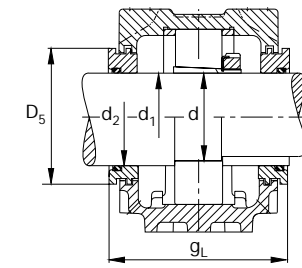

SNV200

Dimensions																						Mass						
D	a	b	c	g	h	m	s	u	v	h ₁	D ₂	D ₃	D ₅	g ₁	g ₂	g ₃	g _L	k	m ₁	n ₁	m ₂	n ₂	n ₃	n ₄	M DIN 931	M ₁ DIN 580	≈ kg	
mm							mm	inch	mm																			
200	410	120	45	175	125	350	M24	7/8	26	32	248	147.5	157.5	154.7	6	5.25	16	192.3 ¹⁾	80	291	88	320	74	111	157	M20	-	21

Shaft d ₁ d	d ₂	Bearings which fit the housing Unsplit bearings				Split spherical roller bearing		Required accessories		Two-lip seal		Labyrinth ring with O ring FAG		Felt seal		Cover	
mm	inch	mm	Codes according to DIN*		FAG		FAG	FAG	FAG	FAG	FAG	FAG	FAG	FAG	FAG	FAG	
85			1319K	20319K	21319K	2319K	22319K	H319 H2319		FRM200/17,5 FRM200/6,5	DH619 DH619	TSV619 TSV619	FSV619 FSV619	DKV200 DKV200			
85.725	3 ³ / ₈		1319K	20319K	21319K	2319K	22319K	H319.306 H2319.306		FRM200/17,5 FRM200/6,5	DH619 DH619	TSV619.306 TSV619.306	FSV619 FSV619	DKV200 DKV200			
95		110 110	6319	1319	20319	21319	2319	22319	KM19 KM19	MB19A MB19A	FRM200/17,5 FRM200/6,5	DH319 DH319	TSV319 TSV319	FSV319 FSV319	DKV200 DKV200		
95.25	3 ³ / ₄		1222K	20222K		22222K	23222K	H222.312 H322.312 H2322.312		FRM200/21 FRM200/13,5 FRM200/5,1	DH522.312 DH522.312 DH522.312	TSV522.312 TSV522.312 TSV522.312	FSV522.312 FSV522.312 FSV522.312	DKV200 DKV200 DKV200			
98.425	3 ⁷ / ₈		1222K	20222K		22222K	23222K	H222.314 H322.314 H2322.314		FRM200/21 FRM200/13,5 FRM200/5,1	DH522.314 DH522.314 DH522.314	TSV522.314 TSV522.314 TSV522.314	FSV522.314 FSV522.314 FSV522.314	DKV200 DKV200 DKV200			
100			1222K	20222K		22222K	23222K	H222 H322 H2322		FRM200/21 FRM200/13,5 FRM200/13,5 FRM200/5,1	DH522 DH522 DH522	TSV522 TSV522 TSV522	FSV522 FSV522 FSV522	DKV200 DKV200 DKV200			
100.013	3 ¹⁵ / ₁₆		1222K	20222K		22222K	23222K	H222.315 H322.315 H2322.315		FRM200/21 FRM200/13,5 FRM200/5,1	DH522 DH522 DH522	TSV522 TSV522 TSV522	FSV522 FSV522 FSV522	DKV200 DKV200 DKV200			
101.6	4		1222K	20222K		22222K	23222K	H222.400 H322.400 H2322.400		FRM200/21 FRM200/13,5 FRM200/13,5 FRM200/5,1	DH522 DH522 DH522	TSV522.400 TSV522.400 TSV522.400	FSV522.400 FSV522.400 FSV522.400	DKV200 DKV200 DKV200			
110		125 125 125	6222	1222	20222	22222	23222		KM22 KM22 KM22	MB22 MB22 MB22	FRM200/21 FRM200/13,5 FRM200/5,1	DH222 DH222 DH222	TSV222 TSV222 TSV222	FSV222 FSV222 FSV222	DKV200 DKV200 DKV200		

* The order designation in the code according to DIN can be taken from the catalogue WL 41520EA "FAG Rolling Bearings"

¹⁾ g_L = 195.3 mm at TSV522.312, TSV522.314, TSV522, TSV522.400 and TSV222

FAG Plummer Block Housings, split

for bearings with cylindrical bore and
for bearings with tapered bore and adapter sleeve

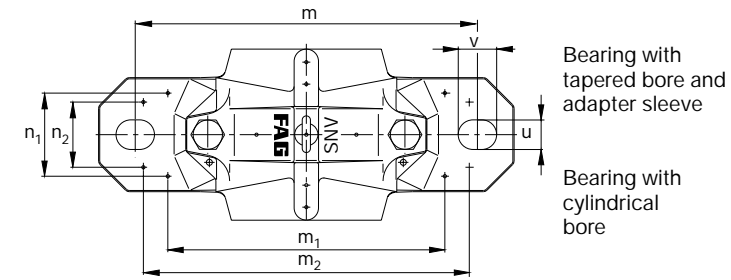
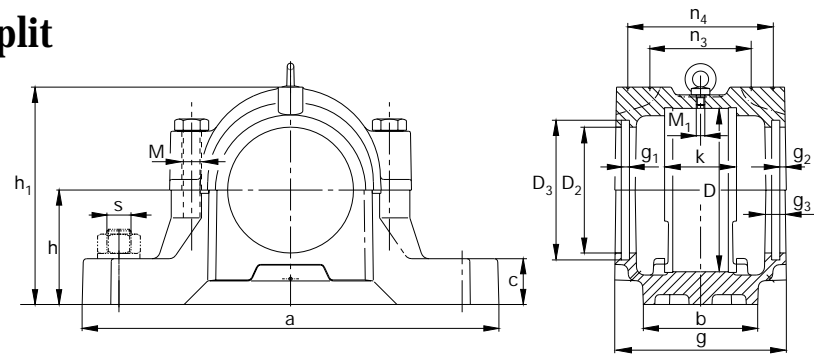

Bearing with tapered bore and adapter sleeve
Bearing with cylindrical bore

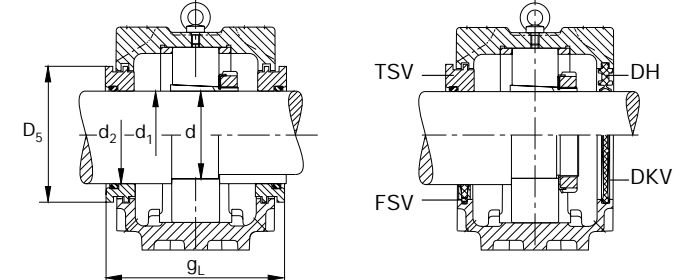

SNV215

Dimensions		b	c	g	h	m	s	u	v	h ₁	D ₂	D ₃	D ₅	g ₁	g ₂	g ₃	g _L	k	m ₁	n ₁	m ₂	n ₂	n ₃	n ₄	M DIN 931	M ₁ DIN 580	Mass ≈ kg	
D	a	mm	mm	mm	mm	mm	mm	mm	mm	mm	mm	mm	mm	mm	mm	mm	mm	mm	mm	mm	mm	mm	mm	mm	mm	mm	mm	kg
215	410	120	45	180	140	350	M24	7/8	26	32	271	157.5	167.5	164.7	6	5.25	16	197.3 ¹⁾	86	297	91	330	74	117	162	M20	M10	24.5

Shaft d ₁ d	d ₂	Bearings which fit the housing Unsplit bearings						Split spherical roller bearing FAG	Required accessories										Cover FAG									
		Codes according to DIN*							Adapter sleeve FAG	Locknut FAG	Lock washer FAG	Locating ring 2 pieces FAG	Two-lip seal FAG	Labyrinth ring with O ring FAG	Felt seal FAG													
mm	inch	mm	mm	mm	mm	mm	mm	mm	mm	mm	mm	mm	mm	mm	mm	mm	mm	mm	mm	mm	mm	mm	mm	mm	mm	mm	mm	mm
87.313	3 ⁷ / ₁₆			1320K	20320K	21320K	2320K	22320K	H320.307 H2320.307				FRM215/19,5 FRM215/6,5	DH620.307	TSV620.307	FSV620.307	DKV215											
88.9	3 ¹ / ₂			1320K	20320K	21320K	2320K	22320K	H320.308 H2320.308				FRM215/19,5 FRM215/6,5	DH620	TSV620.308	FSV620.308	DKV215											
90				1320K	20320K	21320K	2320K	22320K	H320 H2320				FRM215/19,5 FRM215/6,5	DH620	TSV620	FSV620	DKV215											
92.075	3 ⁵ / ₈			1320K	20320K	21320K	2320K	22320K	H320.310 H2320.310				FRM215/19,5 FRM215/6,5	DH620.310	TSV620.310	FSV620.310	DKV215											
93.663	3 ¹¹ / ₁₆			1320K	20320K	21320K	2320K	22320K	H320.311 H2320.311				FRM215/19,5 FRM215/6,5	DH620.310	TSV620.311	FSV620.311	DKV215											
100		115 115	6320	1320	20320	21320	2320	22320						KM20 KM20	MB20A MB20A	FRM215/19,5 FRM215/6,5	DH320	TSV320	FSV320	DKV215								
106.363	4 ³ / ₁₆				20224K			22224K	H3024.403 H3124.403			23224K	222S.403			FRM215/23 FRM215/14 FRM215/14 FRM215/5	DH524.403	TSV524.403	FSV524.403	DKV215								
107.95	4 ¹ / ₄				20224K			22224K	H3024.404 H3124.404 H2324.404			23224K				FRM215/23 FRM215/14 FRM215/5	DH524.403	TSV524.404	FSV524.404	DKV215								
110					20224K			22224K	H3024 H3124			23224K	222SM110T			FRM215/23 FRM215/14 FRM215/14 FRM215/5	DH524	TSV524	FSV524	DKV215								
120		135 135 135	6224		20224			22224	H2324			23224				FRM215/23 FRM215/14 FRM215/5	DH224	TSV224	FSV224	DKV215								

* The order designation in the code according to DIN can be taken from the catalogue WL 41520EA "FAG Rolling Bearings"

¹⁾ g_L = 200.3 mm at TSV524.403, TSV524.404, TSV524 and TSV224

FAG Plummer Block Housings, split

for bearings with cylindrical bore and
for bearings with tapered bore and adapter sleeve

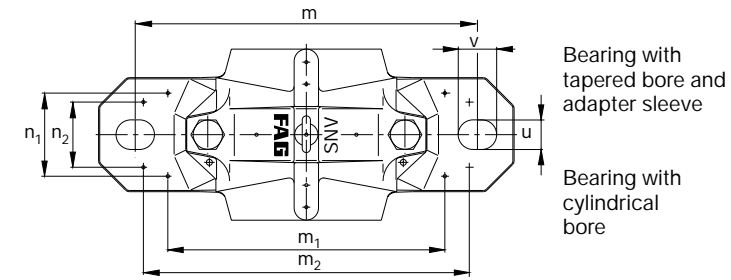
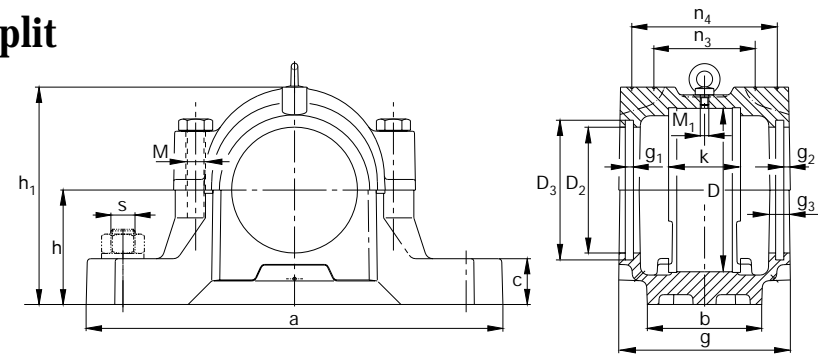

Bearing with tapered bore and adapter sleeve
Bearing with cylindrical bore

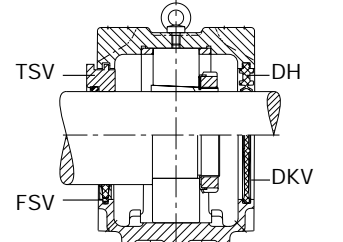
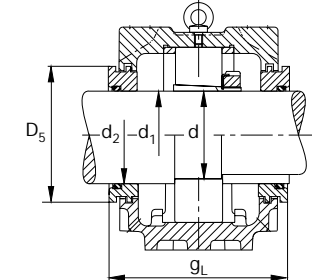

SNV230

Dimensions																								Mass				
D	a	b	c	g	h	m	s	u	v	h ₁	D ₂	D ₃	D ₅	g ₁	g ₂	g ₃	g _L	k	m ₁	n ₁	m ₂	n ₂	n ₃	n ₄	M DIN 931	M ₁ DIN 580	≈ kg	
mm							mm	inch	mm																			
230	445	130	50	190	150	380	M24	1	28	35	291	167.5	177.5	174.7	6	6.25	18	208.3	90	325	97	370	80	122	170	M24	M10	30

Shaft d ₁ d	d ₂	Bearings which fit the housing		Split spherical roller bearing	Required accessories											
		Unsplit bearings	Codes according to DIN*		FAG	Adapter sleeve	Locknut	Lock washer	Locating ring 2 pieces	Two-lip seal	Labyrinth ring with O ring	Felt seal	Cover			
mm	inch	mm		FAG	FAG	FAG	FAG	FAG	FAG	FAG	FAG	FAG	FAG	FAG	FAG	FAG
112.713	4 ⁷ / ₁₆		20226K	22226K	222S.407	H3026.407				FRM230/25	DH526.407	TSV526.407	FSV526.407	DKV230		
				23226K		H3126.407				FRM230/13	DH526.407	TSV526.407	FSV526.407	DKV230		
					222S.408	H2326.407				FRM230/13	DH526.407	TSV526.407	FSV526.407	DKV230		
										FRM230/5	DH526.407	TSV526.407	FSV526.407	DKV230		
114.3	4 ¹ / ₂		20226K	22226K	222S.408	H3026.408				FRM230/25	DH526	TSV526.408	FSV526	DKV230		
				23226K		H3126.408				FRM230/13	DH526	TSV526.408	FSV526	DKV230		
					222S.408	H2326.408				FRM230/13	DH526	TSV526.408	FSV526	DKV230		
										FRM230/5	DH526	TSV526.408	FSV526	DKV230		
115			20226K	22226K	222SM115T	H3026				FRM230/25	DH526	TSV526	FSV526	DKV230		
				23226K		H3126				FRM230/13	DH526	TSV526	FSV526	DKV230		
						H2326				FRM230/13	DH526	TSV526	FSV526	DKV230		
										FRM230/5	DH526	TSV526	FSV526	DKV230		
120.65	4 ³ / ₄		20226K	22226K		H3026.412				FRM230/25	DH526.412	TSV526.412	FSV526.412	DKV230		
				23226K		H3126.412				FRM230/13	DH526.412	TSV526.412	FSV526.412	DKV230		
						H2326.412				FRM230/5	DH526.412	TSV526.412	FSV526.412	DKV230		
130		145	6226	20226						FRM230/25	DH226	TSV226	FSV226	DKV230		
		145			22226					FRM230/13	DH226	TSV226	FSV226	DKV230		
		145				23226				FRM230/5	DH226	TSV226	FSV226	DKV230		

* The order designation in the code according to DIN can be taken from the catalogue WL 41520EA "FAG Rolling Bearings"

FAG Plummer Block Housings, split

for bearings with cylindrical bore and
for bearings with tapered bore and adapter sleeve

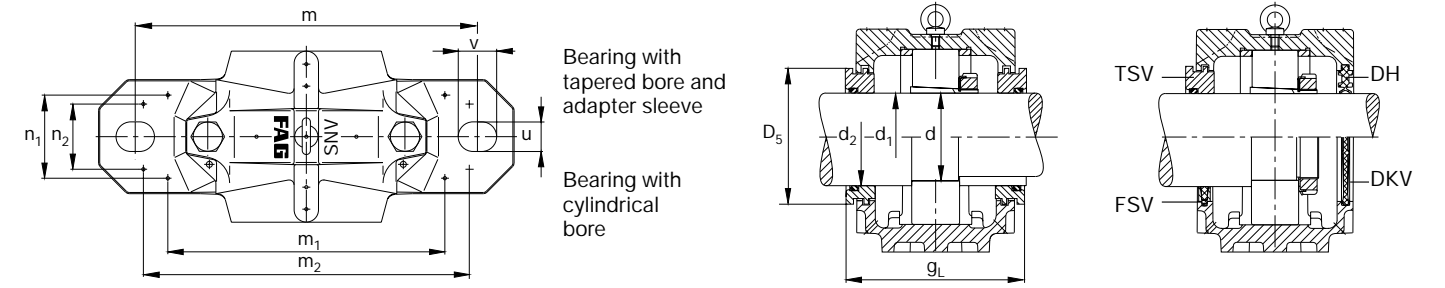
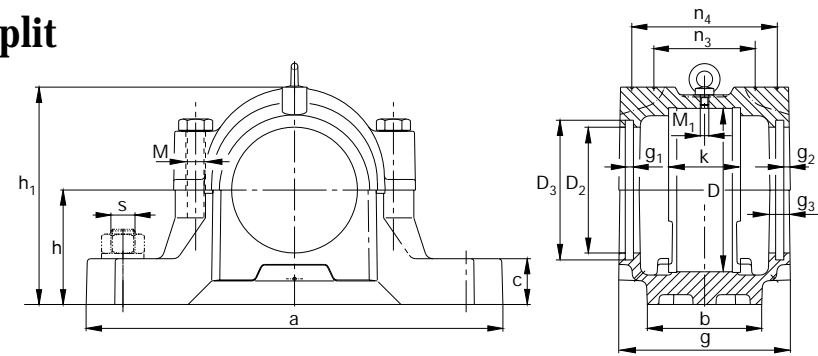

SNV240

Dimensions		b	c	g	h	m	s	u	v	h ₁	D ₂	D ₃	D ₅	g ₁	g ₂	g ₃	g _L	k	m ₁	n ₁	m ₂	n ₂	n ₃	n ₄	M DIN 931	M ₁ DIN 580	Mass ≈ kg	
D	a						mm	inch	mm				mm	mm	mm	mm	mm	mm	mm									
240	450	130	50	185	150	390	M24	1	28	35	298	147.5	157.5	154.7	6	6.25	18	203.3	90	328	96	370	80	120	165	M24	M10	32
Shaft d ₁ d			d ₂	Bearings which fit the housing Unsplit bearings										Required accessories														
mm	inch		mm	Codes according to DIN*										Adapter sleeve	Locknut	Lock washer	Locating ring 2 pieces	Two-lip seal	Labyrinth ring with O ring FAG	Felt seal	Cover							
FAG	FAG	FAG	FAG	FAG	FAG	FAG	FAG	FAG	FAG	FAG	FAG	FAG	FAG	FAG	FAG	FAG	FAG	FAG	FAG	FAG	FAG	FAG	FAG	FAG	FAG	FAG	FAG	FAG
95.25	3 ³ / ₄			20322K	21322K					22322K				H322.312 H2322.312			FRM240/20 FRM240/5	DH522.312 DH522.312	TSV522.312 TSV522.312	FSV522.312 FSV522.312	DKV200 DKV200							
98.425	3 ⁷ / ₈			20322K	21322K					22322K				H322.314 H2322.314			FRM240/20 FRM240/5	DH522.314 DH522.314	TSV522.314 TSV522.314	FSV522.314 FSV522.314	DKV200 DKV200							
100				20322K	21322K					22322K				H322 H2322			FRM240/20 FRM240/5	DH522 DH522	TSV522 TSV522	FSV522 FSV522	DKV200 DKV200							
100.013	3 ¹⁵ / ₁₆			20322K	21322K					22322K				H322.315 H2322.315			FRM240/20 FRM240/5	DH522 DH522	TSV522 TSV522	FSV522 FSV522	DKV200 DKV200							
101.6	4			20322K	21322K					22322K				H322.400 H2322.400			FRM240/20 FRM240/5	DH522 DH522	TSV522.400 TSV522.400	FSV522.400 FSV522.400	DKV200 DKV200							
110			125 125	6322	20322	21322				22322					KM22 KM22	MB22 MB22	FRM240/20 FRM240/5	DH222 DH222	TSV222 TSV222	FSV222 FSV222	DKV200 DKV200							

* The order designation in the code according to DIN can be taken from the catalogue WL 41520EA "FAG Rolling Bearings"

FAG Plummer Block Housings, split

for bearings with cylindrical bore and
for bearings with tapered bore and adapter sleeve

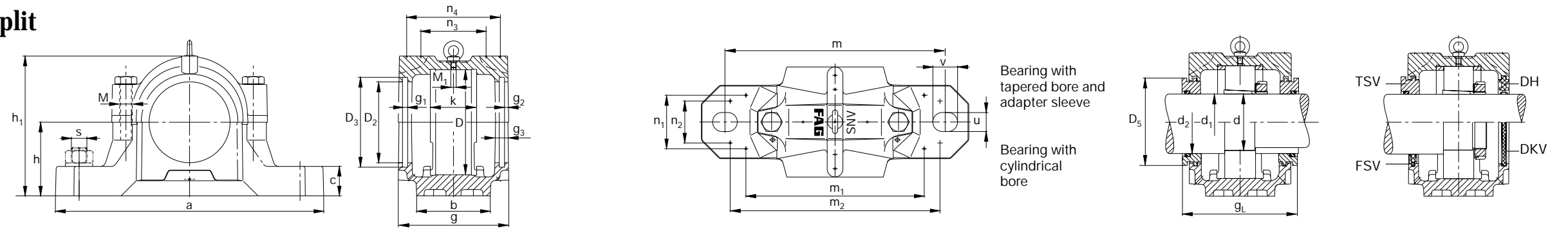

SNV250

Dimensions																						Mass							
D	a	b	c	g	h	m	s	u	v	h ₁	D ₂	D ₃	D ₅	g ₁	g ₂	g ₃	g _L	k	m ₁	n ₁	m ₂	n ₂	n ₃	n ₄	M DIN 931	M ₁ DIN 580	≈ kg		
mm							mm inch	mm																					
250	500	150	50	200	150	420	M30 1 ¹ / ₄	35	42	304	177.5	187.5	184.2	6	6.25	18	218.3	98	342	109	400	92	131	180	M24	M10	38		
Shaft d ₁ d			d ₂	Bearings which fit the housing Unsplit bearings				Split spherical roller bearing		Required accessories																			
mm	inch	mm		Codes according to DIN*				FAG		FAG	FAG	FAG	FAG	FAG	FAG	FAG	FAG	FAG	FAG	FAG	FAG	FAG	FAG	FAG	FAG	FAG	FAG	FAG	FAG
125				20228K				22228K 23228K 222SM125T		H3028 H3128 H2328									FRM250/28 FRM250/15 FRM250/15 FRM250/5		DH528 DH528 DH528	TSV528 TSV528 TSV528	FSV528 FSV528 FSV528	DKV250 DKV250 DKV250					
125.413	4¹⁵/₁₆			20228K				22228K 23228K		H3028.415 H3128.415 H2328.415									FRM250/28 FRM250/15 FRM250/5		DH528 DH528 DH528	TSV528.415 TSV528.415 TSV528.415	FSV528 FSV528 FSV528	DKV250 DKV250 DKV250					
127	5			20228K				22228K 23228K 222S.500		H3028.500 H3128.500 H2328.500									FRM250/28 FRM250/15 FRM250/15 FRM250/5		DH528 DH528 DH528	TSV528.500 TSV528.500 TSV528.500	FSV528.500 FSV528.500 FSV528.500	DKV250 DKV250 DKV250					
140		155 155 155	6228	20228				22228 23228												FRM250/28 FRM250/15 FRM250/5		DH228 DH228 DH228	TSV228 TSV228 TSV228	FSV228 FSV228 FSV228	DKV250 DKV250 DKV250				

* The order designation in the code according to DIN can be taken from the catalogue WL 41520EA "FAG Rolling Bearings"

FAG Plummer Block Housings, split

for bearings with cylindrical bore and
for bearings with tapered bore and adapter sleeve

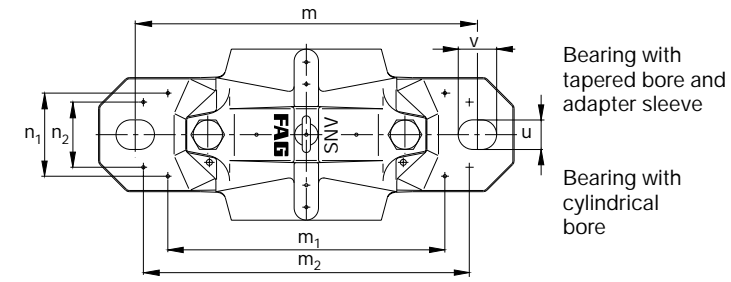
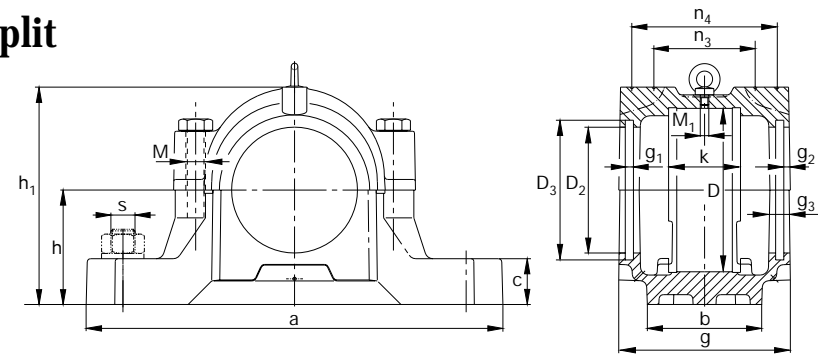

Bearing with tapered bore and adapter sleeve
Bearing with cylindrical bore

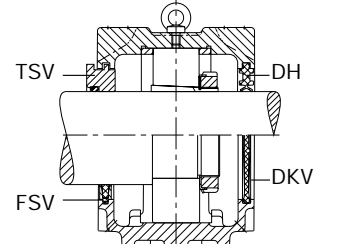
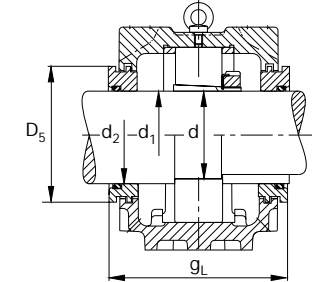

SNV260

Dimensions		b	c	g	h	m	s	u	v	h ₁	D ₂	D ₃	D ₅	g ₁	g ₂	g ₃	g _L	k	m ₁	n ₁	m ₂	n ₂	n ₃	n ₄	M DIN 931	M ₁ DIN 580	Mass ≈ kg
D	a						mm inch	mm																			
260	530	160	60	190	160	450	M30 1 ¹ / ₄	35	42	321	157.5	167.5	164.7	6	6.25	18	208.3	96	372	113	430	100	125	170	M24	M10	48

Shaft d ₁ d	d ₂	Bearings which fit the housing		Split spherical roller bearing	Required accessories											
		Unsplit bearings	Codes according to DIN*		Adapter sleeve	Locknut	Lock washer	Locating ring 2 pieces	Two-lip seal	Labyrinth ring with O ring	Felt seal	Cover				
mm	inch	mm		FAG	FAG	FAG	FAG	FAG	FAG	FAG	FAG	FAG	FAG	FAG	FAG	FAG
106.363	4³/₁₆		20324K		22324K	H3124.403 H2324.403				FRM260/20,5 FRM260/5	DH524.403 DH524.403	TSV524.403 TSV524.403	FSV524.403 FSV524.403	DKV215 DKV215		
107.95	4¹/₄		20324K		22324K	H3124.404 H2324.404				FRM260/20,5 FRM260/5	DH524.403 DH524.403	TSV524.404 TSV524.404	FSV524.404 FSV524.404	DKV215 DKV215		
110			20324K		22324K	H3124 H2324				FRM260/20,5 FRM260/5	DH524 DH524	TSV524 TSV524	FSV524 FSV524	DKV215 DKV215		
120		135 135	6324	20324	22324					FRM260/20,5 FRM260/5	DH224 DH224	TSV224 TSV224	FSV224 FSV224	DKV215 DKV215		

* The order designation in the code according to DIN can be taken from the catalogue WL 41520EA "FAG Rolling Bearings"

FAG Plummer Block Housings, split

for bearings with cylindrical bore and
for bearings with tapered bore and adapter sleeve

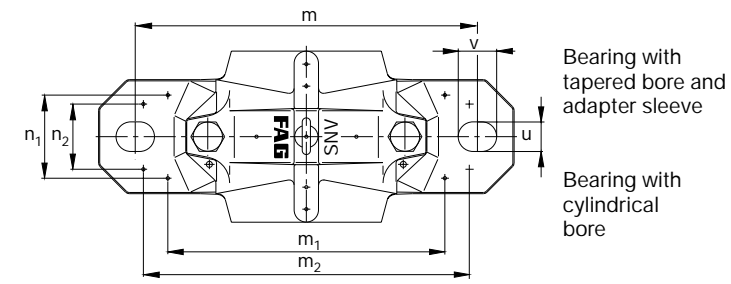
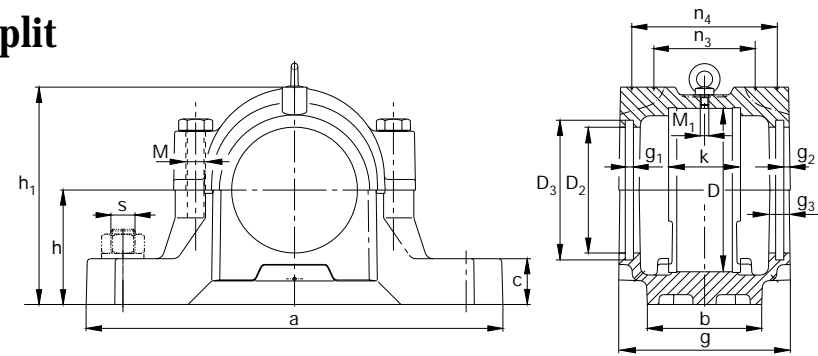

Bearing with tapered bore and adapter sleeve
Bearing with cylindrical bore

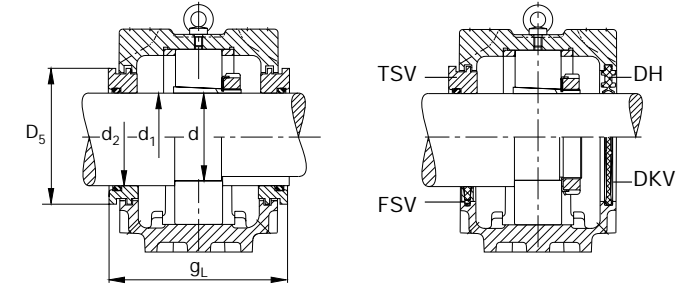

SNV270

Dimensions																								Mass				
D	a	b	c	g	h	m	s	u	v	h ₁	D ₂	D ₃	D ₅	g ₁	g ₂	g ₃	g _L	k	m ₁	n ₁	m ₂	n ₂	n ₃	n ₄	M DIN 931	M ₁ DIN 580	≈ kg	
mm							mm inch	mm																				
270	530	160	60	215	160	450	M30 1 1/4	35	42	328	192.5	202.5	199.2	6	6.25	18	233.3	106	372	116	430	100	143	195	M24	M10	45.5	

Shaft d ₁ d	d ₂	Bearings which fit the housing Unsplit bearings		Split spherical roller bearing	Required accessories										Cover
mm	inch	mm	Codes according to DIN*	FAG	Adapter sleeve	Locknut	Lock washer	Locating ring 2 pieces	Two-lip seal	Labyrinth ring with O ring FAG	Felt seal	Cover			
					FAG	FAG	FAG	FAG	FAG	FAG	FAG	FAG			
131.763	5 3/16		20230K	22230K 222S.503 23230K	H3030.503 H3130.503 H2330.503			FRM270/30,5 FRM270/16,5 FRM270/16,5 FRM270/5	DH530.503 DH530.503 DH530.503 DH530.503	TSV530.503 TSV530.503 TSV530.503 TSV530.503	FSV530.503 FSV530.503 FSV530.503 FSV530.503	DKV270 DKV270 DKV270 DKV270			
133.35	5 1/4		20230K	22230K 23230K	H3030.504 H3130.504 H2330.504			FRM270/30,5 FRM270/16,5 FRM270/5	DH530.504 DH530.504 DH530.504	TSV530.504 TSV530.504 TSV530.504	FSV530.504 FSV530.504 FSV530.504	DKV270 DKV270 DKV270			
135			20230K	22230K 23230K	H3030 H3130 H2330			FRM270/30,5 FRM270/16,5 FRM270/16,5 FRM270/5	DH530 DH530 DH530 DH530	TSV530 TSV530 TSV530 TSV530	FSV530 FSV530 FSV530 FSV530	DKV270 DKV270 DKV270 DKV270			
150		165 165 165	6230 20230	22230 23230				FRM270/30,5 FRM270/16,5 FRM270/5	DH230 DH230 DH230	TSV230 TSV230 TSV230	FSV230 FSV230 FSV230	DKV270 DKV270 DKV270			

* The order designation in the code according to DIN can be taken from the catalogue WL 41520EA "FAG Rolling Bearings"

FAG Plummer Block Housings, split

for bearings with cylindrical bore and
for bearings with tapered bore and adapter sleeve

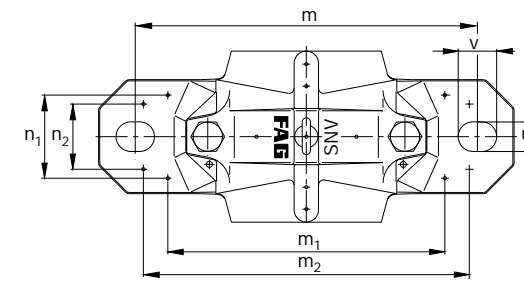
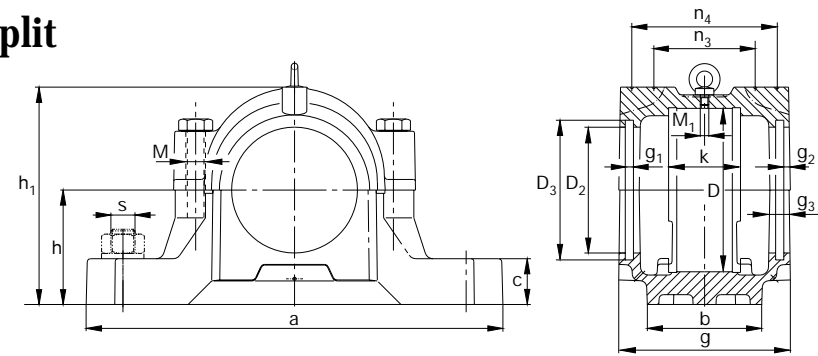

Bearing with tapered bore and adapter sleeve
Bearing with cylindrical bore

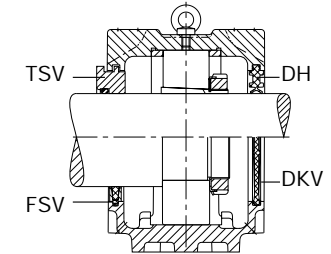
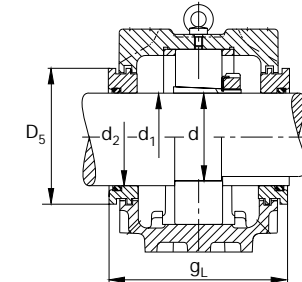

SNV280

Dimensions		b	c	g	h	m	s	u	v	h ₁	D ₂	D ₃	D ₅	g ₁	g ₂	g ₃	g _L	k	m ₁	n ₁	m ₂	n ₂	n ₃	n ₄	M DIN 931	M ₁ DIN 580	Mass ≈ kg
D	a						mm inch	mm																			
280	550	160	60	205	170	470	M30 1 ¹ / ₄	35	42	344	167.5	177.5	174.7	6	6.25	18	223.3	103	392	114	450	100	136	185	M24	M10	55

Shaft d ₁ d	d ₂	Bearings which fit the housing		Split spherical roller bearing	Required accessories																			
		Unsplit bearings	Codes according to DIN*		FAG	Adapter sleeve	Locknut	Lock washer	Locating ring 2 pieces	Two-lip seal	Labyrinth ring with O ring	Felt seal	Cover											
mm	inch	mm		FAG	FAG	FAG	FAG	FAG	FAG	FAG	FAG	FAG	FAG	FAG	FAG	FAG								
112.713	4 ⁷ / ₁₆		20326K		22326K	H3126.407 H2326.407				FRM280/22,5 FRM280/5	DH526.407 DH526.407	TSV526.407 TSV526.407	FSV526.407 FSV526.407	DKV230 DKV230										
114.3	4 ¹ / ₂		20326K		22326K	H3126.408 H2326.408				FRM280/22,5 FRM280/5	DH526 DH526	TSV526.408 TSV526.408	FSV526 FSV526	DKV230 DKV230										
115			20326K		22326K	H3126 H2326				FRM280/22,5 FRM280/5	DH526 DH526	TSV526 TSV526	FSV526 FSV526	DKV230 DKV230										
120.65	4 ³ / ₄		20326K		22326K	H3126.412 H2326.412				FRM280/22,5 FRM280/5	DH526.412 DH526.412	TSV526.412 TSV526.412	FSV526.412 FSV526.412	DKV230 DKV230										
130		150 150	6326	20326	22326										KM26 KM26	MB26 MB26	FRM280/22,5 FRM280/5				DH326 DH326	TSV326 TSV326	FSV326 FSV326	DKV230 DKV230

* The order designation in the code according to DIN can be taken from the catalogue WL 41520EA "FAG Rolling Bearings"

FAG Plummer Block Housings, split

for bearings with cylindrical bore and
for bearings with tapered bore and adapter sleeve

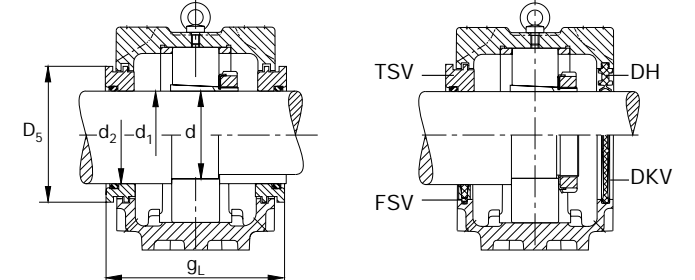
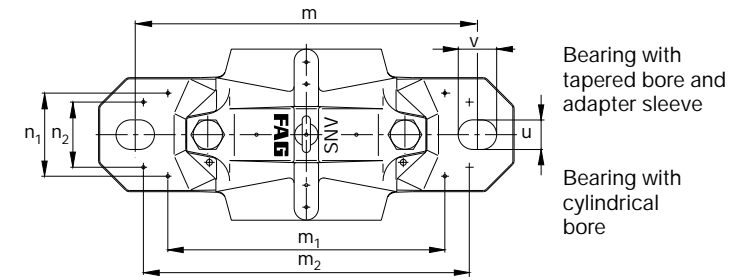
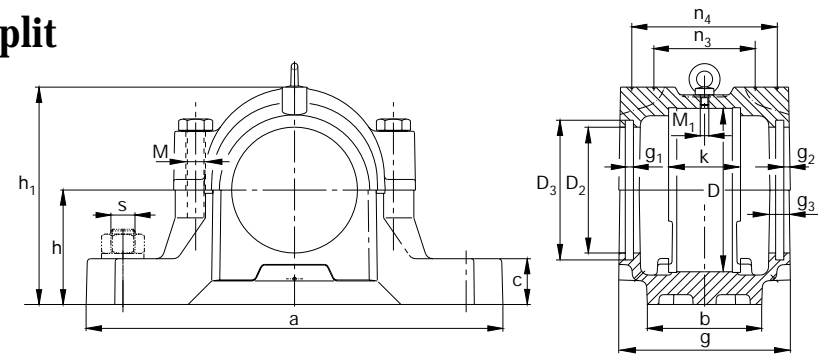

SNV290

Dimensions																						Mass							
D	a	b	c	g	h	m	s	u	v	h ₁	D ₂	D ₃	D ₅	g ₁	g ₂	g ₃	g _L	k	m ₁	n ₁	m ₂	n ₂	n ₃	n ₄	M DIN 931	M ₁ DIN 580	≈ kg		
mm							mm inch	mm																					
290	550	160	60	225	170	470	M30 1 ¹ / ₄	35	42	351	202.5	212.5	209.2	6	6.25	18	243.3	114	392	120	450	100	152	205	M24	M10	53.8		
Shaft d ₁ d			d ₂	Bearings which fit the housing Unsplit bearings				Split spherical roller bearing		Required accessories																			
mm	inch	mm		Codes according to DIN*				FAG		FAG	Adapter sleeve	Locknut	Lock washer	Locating ring 2 pieces	Two-lip seal	Labyrinth ring with O ring	Felt seal	Cover											
											FAG	FAG	FAG	FAG	FAG	FAG	FAG	FAG											
138.113	5 ⁷ / ₁₆			20232K				22232K			H3032.507 H3132.507			FRM290/33 FRM290/17 FRM290/17 FRM290/5	DH532.507 DH532.507 DH532.507 DH532.507	TSV532.507 TSV532.507 TSV532.507 TSV532.507	FSV532.507 FSV532.507 FSV532.507 FSV532.507	DKV290 DKV290 DKV290 DKV290											
139.7	5 ¹ / ₂			20232K				22232K			H3032.508 H3132.508 H2332.508			FRM290/33 FRM290/17 FRM290/5	DH532 DH532 DH532	TSV532 TSV532 TSV532	FSV532 FSV532 FSV532	DKV290 DKV290 DKV290											
140				20232K				22232K			H3032 H3132			FRM290/33 FRM290/17 FRM290/17 FRM290/5	DH532 DH532 DH532 DH532	TSV532 TSV532 TSV532 TSV532	FSV532 FSV532 FSV532 FSV532	DKV290 DKV290 DKV290 DKV290											
160		175 175 175	6232	20232				22232				23232																	

* The order designation in the code according to DIN can be taken from the catalogue WL 41520EA "FAG Rolling Bearings"

FAG Plummer Block Housings, split

for bearings with cylindrical bore and
for bearings with tapered bore and adapter sleeve

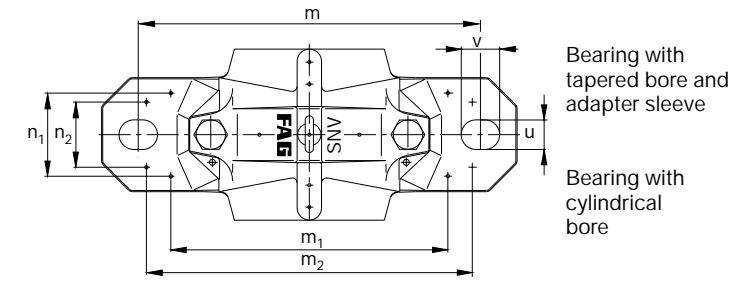
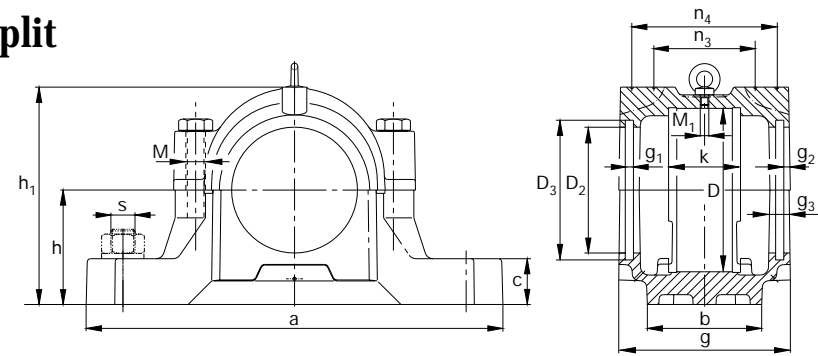

Bearing with tapered bore and adapter sleeve
Bearing with cylindrical bore

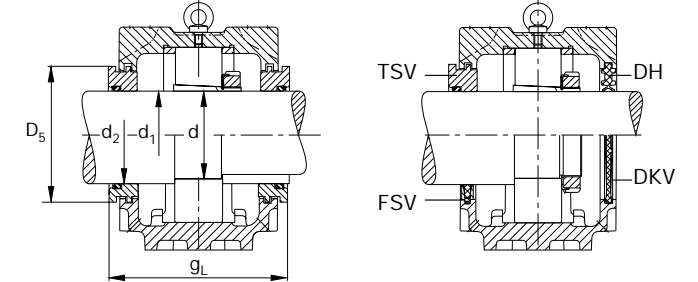

SNV300

Dimensions																						Mass						
D	a	b	c	g	h	m	s	u	v	h ₁	D ₂	D ₃	D ₅	g ₁	g ₂	g ₃	g _L	k	m ₁	n ₁	m ₂	n ₂	n ₃	n ₄	M DIN 931	M ₁ DIN 580	≈ kg	
mm							mm inch	mm																				
300	620	170	65	215	180	520	M30 1 ¹ / ₄	35	42	366	177.5	187.5	184.2	6	6.25	18	233.3	112	442	123	500	100	146	195	M24	M10	70	

Shaft d ₁ d	d ₂	Bearings which fit the housing		Split spherical roller bearing	Required accessories																
		Unsplit bearings	Codes according to DIN*		Adapter sleeve	Locknut	Lock washer	Locating ring 2 pieces	Two-lip seal	Labyrinth ring with O ring	Felt seal	Cover									
mm	inch	mm		FAG	FAG	FAG	FAG	FAG	FAG	FAG	FAG	FAG	FAG	FAG	FAG	FAG	FAG				
125				20328K	22328K	H3128 H2328				FRM300/25 FRM300/5	DH528 DH528	TSV528 TSV528	FSV528 FSV528	DKV250 DKV250							
125.413	4 ¹⁵ / ₁₆			20328K	22328K	H3128.415 H2328.415				FRM300/25 FRM300/5	DH528 DH528	TSV528.415 TSV528.415	FSV528 FSV528	DKV250 DKV250							
127	5			20328K	22328K	H3128.500 H2328.500				FRM300/25 FRM300/5	DH528 DH528	TSV528.500 TSV528.500	FSV528.500 FSV528.500	DKV250 DKV250							
140		160 160	6328	20328	22328										KM28 KM28	MB28 MB28	FRM300/25 FRM300/5	DH328 DH328	TSV328 TSV328	FSV328 FSV328	DKV250 DKV250

* The order designation in the code according to DIN can be taken from the catalogue WL 41520EA "FAG Rolling Bearings"

FAG Plummer Block Housings, split

for bearings with cylindrical bore and
for bearings with tapered bore and adapter sleeve

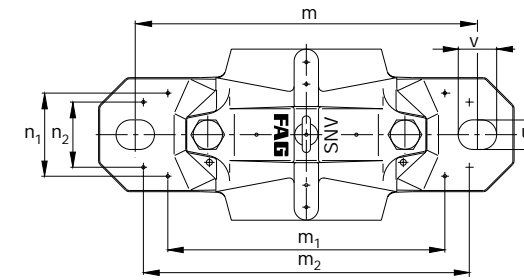
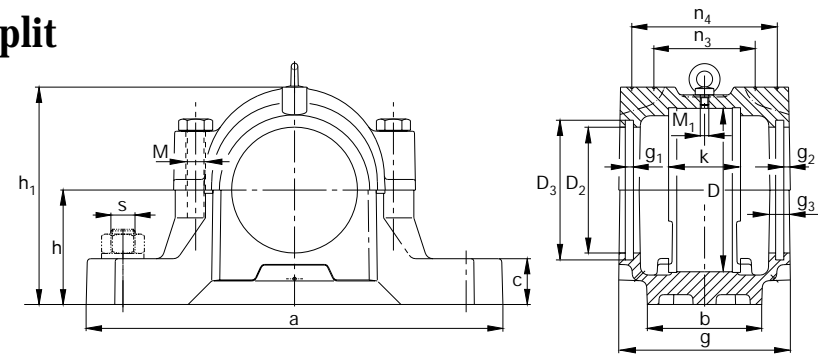

Bearing with tapered bore and adapter sleeve
Bearing with cylindrical bore

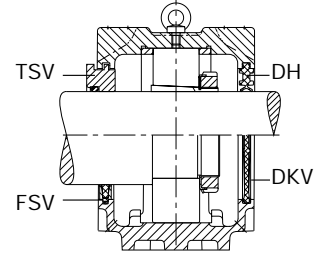
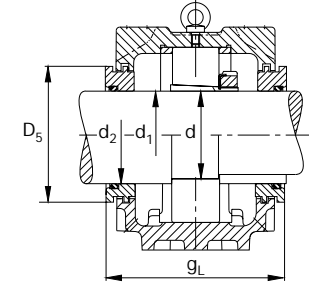

SNV320

Dimensions		b	c	g	h	m	s	u	v	h ₁	D ₂	D ₃	D ₅	g ₁	g ₂	g ₃	g _L	k	m ₁	n ₁	m ₂	n ₂	n ₃	n ₄	M DIN 931	M ₁ DIN 580	Mass ≈ kg
D	a						mm inch	mm																			
320	650	180	65	225	190	560	M30 1 ¹ / ₄	35	42	386	192.5	202.5	199.2	6	6.25	18	243.3	118	482	130	540	100	154	205	M24	M10	95

Shaft d ₁ d	d ₂	Bearings which fit the housing		Split spherical roller bearing	Required accessories											
		Unsplit bearings	Codes according to DIN*		Adapter sleeve	Locknut	Lock washer	Locating ring 2 pieces	Two-lip seal	Labyrinth ring with O ring	Felt seal	Cover				
mm	inch	mm		FAG	FAG	FAG	FAG	FAG	FAG	FAG	FAG	FAG	FAG	FAG	FAG	FAG
131.763	5 ³ / ₁₆		20330K	22330K	H3130.503 H2330.503				FRM320/26,5 FRM320/5	DH530.503 DH530.503	TSV530.503 TSV530.503	FSV530.503 FSV530.503	DKV270 DKV270			
133.35	5 ¹ / ₄		20330K	22330K	H3130.504 H2330.504				FRM320/26,5 FRM320/5	DH530.504 DH530.504	TSV530.504 TSV530.504	FSV530.504 FSV530.504	DKV270 DKV270			
135			20330K	22330K	H3130 H2330				FRM320/26,5 FRM320/5	DH530 DH530	TSV530 TSV530	FSV530 FSV530	DKV270 DKV270			
150		170 170	6330	20330					FRM320/26,5 FRM320/5	DH330 DH330	TSV330 TSV330	FSV330 FSV330	DKV270 DKV270			

* The order designation in the code according to DIN can be taken from the catalogue WL 41520EA "FAG Rolling Bearings"

FAG Plummer Block Housings, split

for bearings with cylindrical bore and
for bearings with tapered bore and adapter sleeve

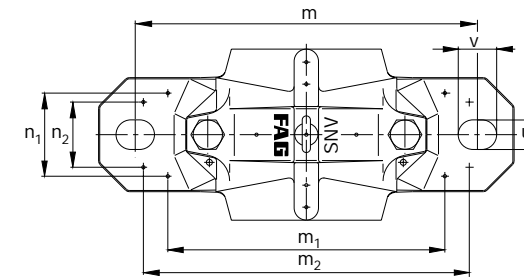
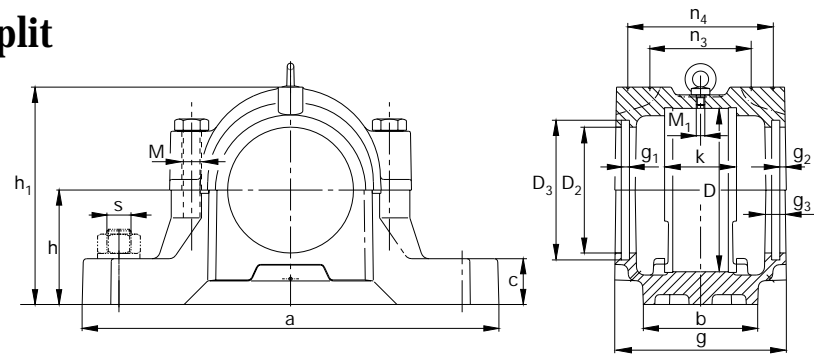

Bearing with tapered bore and adapter sleeve
Bearing with cylindrical bore

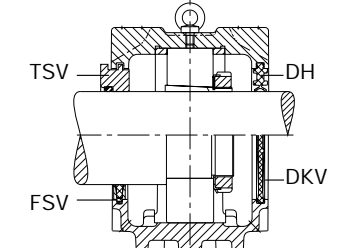
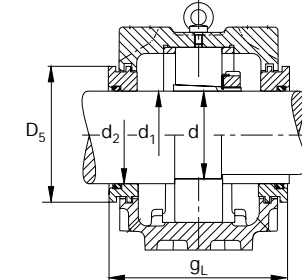

SNV340

Dimensions		b	c	g	h	m	s	u	v	h ₁	D ₂	D ₃	D ₅	g ₁	g ₂	g ₃	g _L	k	m ₁	n ₁	m ₂	n ₂	n ₃	n ₄	M DIN 931	M ₁ DIN 580	Mass ≈ kg
D	a						mm inch	mm																			
340	680	190	70	235	200	580	M36 1 1/2	42	50	406	202.5	212.5	209.2	6	6.25	18	253.3	124	489	138	570	100	162	215	M30	M10	115

Shaft d ₁ d	d ₂	Bearings which fit the housing		Split spherical roller bearing	Required accessories											
		Unsplit bearings	Codes according to DIN*		FAG	Adapter sleeve	Locknut	Lock washer	Locating ring 2 pieces	Two-lip seal	Labyrinth ring with O ring	Felt seal	Cover			
mm	inch	mm		FAG	FAG	FAG	FAG	FAG	FAG	FAG	FAG	FAG	FAG	FAG	FAG	FAG
138.113	5 7/16		20332K		22332K	H3132.507 H2332.507				FRM340/28 FRM340/5	DH532.507 DH532.507	TSV532.507 TSV532.507	FSV532.507 FSV532.507	DKV290 DKV290		
139.7	5 1/2		20332K		22332K	H3132.508 H2332.508				FRM340/28 FRM340/5	DH532 DH532	TSV532 TSV532	FSV532 FSV532	DKV290 DKV290		
140			20332K		22332K	H3132 H2332				FRM340/28 FRM340/5	DH532 DH532	TSV532 TSV532	FSV532 FSV532	DKV290 DKV290		
160		180 180	6332	20332	22332					FRM340/28 FRM340/5	DH332 DH332	TSV332 TSV332	FSV332 FSV332	DKV290 DKV290		

* The order designation in the code according to DIN can be taken from the catalogue WL 41520EA "FAG Rolling Bearings"

FAG Split Plummer Block Housings of Series SNV
for shaft diameters of 20 to 160 mm and $\frac{3}{4}$ to $5\frac{1}{2}$ inches

Publ. No. WL 90118/3 EC

FAG Bearings Limited

5965 Coopers Avenue,
Mississauga, Ontario, Canada L4Z 1R9
Tel. (0905) 890-9770 · Fax (0905) 890-9779

FAG Split Plummer Block Housings of Series SNV for shaft diameters of 20 to 160 mm and $\frac{3}{4}$ to $5\frac{1}{2}$ inches

Every care has been taken to ensure the correctness of the information contained in this publication but no liability can be accepted for any errors or omissions. We reserve the right to make changes in the interest of technical progress.

© FAG 1998 · This publication or parts thereof may not be reproduced without our permission.

WL 90 118/3 EA/96/10/98

Printed in Germany by Weppert GmbH & Co. KG, Schweinfurt