

Racehorse

PowerGrip® GT2 Belt Drives

For more power at less cost in high-speed applications.



Table of Contents

Description	Page	Description	Page
Introduction to PowerGrip® Belt Drives	2-7	Belt Drive Tensioners	125
PowerGrip® Belt Drive Selection Procedure	8-9	PowerGrip GT2 Idler Sprockets	125
High Speed Drive Survey and Energy Savings Worksheet	10	Sprocket Specification Tables	126-129
PowerGrip® GT2® Belt Pitch Selection Guide.	11	Engineering Data	130
PowerGrip® Timing Belt Pitch Selection Guide	11	Section I—Application Design Considerations.	130
NEMA Minimum Recommended Sprocket Outside Diameters	12	1. Gear Motors/Speed Reducer Drives	130
PowerGrip GT2 Belt Drives	13	2. Electric Motor Dimensions	131
Stock Lengths and Widths.	14	3. Minimum Recommended Sprocket Diameters for General Purpose Electric Motors	132
Basic PowerGrip Service Factors	15	4. High Driven Inertia	132
Belt Drive Selection Tables		5. Air Moving Drives	132
5mm Pitch Belts	16-29	6. Linear Motion Drives	133
8mm Pitch Belts	30-35	7. High Performance Vehicle Applications	133
14mm Pitch Belts	36-43	8. Belt Drive Registration	133
Power Rating Tables		9. Belt Drive Noise	134
5mm Pitch Belts	44-45	10. Use of Flanged Sprockets	134
8mm Pitch Belts	46-48	11. Fixed (non-adjustable) Center Distance	134
14mm Pitch Belts	49-51	12. Use of Idlers	135
Drive Selection Tables	52-55	13. Minimum Belt Wrap and Tooth Engagement.	135
Power Rating Tables		14. Adverse Operation Conditions	136
20mm Pitch Belts	56-58	Section II—Engineering Design Considerations.	136
PowerGrip Timing Belt Drives.	59	1. Belt Storage and Handling	136
Stock Lengths and Widths.	60	2. Center Distance and Belt Length.	136
Drive Selection Tables		3. Tooth Profiles	137
XL, 0.200" Pitch Belts	61-64	4. Static Conductivity	137
L, 0.375" Pitch Belts	65-70	5. Sprocket Diameter—Speed	138
H, 0.500" Pitch Belts	71-74	6. Efficiency.	138
Horsepower Rating Tables		7. Belt Tolerances.	139
XL, 0.200" Pitch Belts	75-76	8. Belt Installation Tension	139-140
L, 0.375" Pitch Belts	77-79	9. Center Distance Allowances for Installation and Testing	141
H, 0.500" Pitch Belts	80-84	10. Drive Alignment	141
Long Length Belting	85-94	11. Belt Installation	142
PowerGrip Twin Power Belts	95-97	12. Belt Pull Calculations.	142
Drive Selection Procedure	98-99	13. Bearing/Shaft Load Calculations.	142
PowerGrip GT2 Sprocket Specifications.	100	14. Self-Generated Tension	143
Sprocket Specifications Tables		Technical Data	
5mm Pitch Sprockets	101-102	Made-To-Order (MTO) PowerGrip Belts	144
8mm Pitch Sprockets	103-106	Trouble Shooting	145-146
14mm Pitch Sprockets	107-111	Standard Calculations	147
PowerGrip HTD® Sprocket Specifications	112	Useful Formulas and Calculations	148-149
20mm Pitch Sprockets	113-114	Synchronous Belt Product Design Catalogs	150
PowerGrip Timing Belt Pulleys	115	Synchronous Belt Standard Product Line Listing	150-164
Sprocket Specifications	116-118	Application Examples	165-168
Taper-Lock Bushings	119		
QD Bushings.	120		
Bushing and Keyseat Information.	121-122		
Taper-Lock Type Sprocket Installation and Removal	123		
QD Type Sprocket Installation and Removal	124		

Low speed. High speed. And any speed in between. Gates has your total synchronous belt drive system solution!

Synchronous belt drives are being used more extensively than ever for the transfer of power from one shaft to another, multiplication of torque, speed reduction or increase, and synchronization of shaft operations.

Gates, the world's recognized leader in synchronous belt technology, continues to meet all your needs for synchronous belts, sprockets and bushings across the broadest range of industry applications. Choose from a full line of quality products featuring leading-edge technologies that deliver the advantages you're looking for:

- *Reduced downtime*
- *Reduced over-all drive cost*
- *Reduced drive package size*
- *Increased component life*
- *Increased performance*
- *Energy savings*
- *Reduced acquisition costs*
- *Reduced transaction costs*
- *Increased drive design options*

New, improved synchronous belt lines. The latest innovations in Gates synchronous drive systems are two redesigned and reengineered belt and sprocket lines. They are the clear winners in overall cost, drive selection options and performance when compared to any other belt drive products on the market today.

PowerGrip® GT²

The Racehorse. This is the performance choice for a wide variety of high-speed (above 500 rpm) drive applications. PowerGrip GT2 will deliver more power at a lower overall cost than any other rubber synchronous belt drive system available.

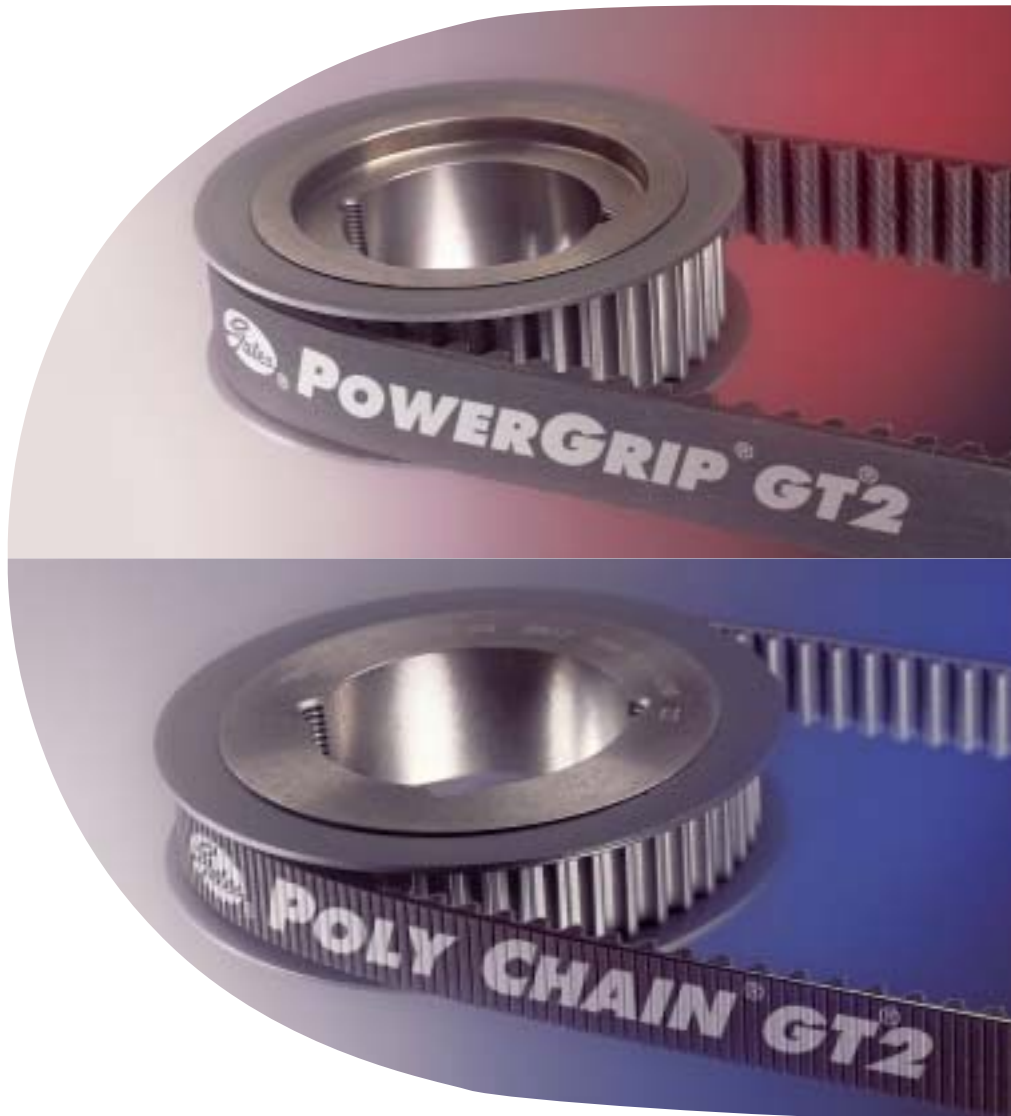

Poly Chain® GT²

The Workhorse. This is the optimal choice in meeting your needs for low-speed (below 500 rpm), high-torque drive applications. The powerful Poly Chain GT2 polyurethane belt drive system will outperform roller chain drives and any rubber belt drive system on the market today, delivering the lowest-cost belt drive system available for low-speed, high-torque applications.

And we can prove it!

Taper-Lock® sprockets & bushings. Poly Chain GT2 and PowerGrip GT2 belt drive systems feature Taper-Lock bushings. Advantages of the Taper-Lock system include:



- Industry-proven robustness
- True running, concentric
- Extensive use in roller chain sprockets
- Easy installation and removal
- Allows compact sprocket hub designs
- Short length-thru-bore dimensions
- Flush mount with no protruding hubs
- Installs with less axial sprocket movement than other bushing systems

Made-to-order sprockets. Gates Made-to-Order (MTO) Metal Department supports synchronous MTO sprockets with 90% of Requests For Quote (RFQ) provided within 48 hours and 84% of quotes provided within 24 hours. Quoted delivery dates are met at a 97% rate and most deliveries are made within four weeks. Call 800-709-6001 for more information.

Gates Compass® CD-ROM: selection, maintenance, and design tool. The Gates Compass CD-ROM is a powerful tool offering a variety of useful information and features. It makes choosing the right drive system fast and easy. Compass contains *Design Flex™ II*, *Design View™* and *Design OHL™* for invaluable assistance in product selection, drive design, energy savings calculations, installation and system cost savings. The CD also contains eight instructional videos covering topics such as belt drive

troubleshooting, tensioning, safety and installation. The Compass CD-ROM is available through authorized Gates Industrial Power Transmission Distributors.

A partnership commitment. To ensure that you get the synchronous drive systems that are right for your applications, Gates provides the industry's leading support program and the largest distributor network. You get local inventory availability and a single source for all your needs. You also get access to Gates Product Application Engineering Support for unmatched design and problem-solving expertise in every aspect of synchronous drive operation. You're backed by the industry's largest manufacturer's field sales force, voted number one in a recent *Selling Power* magazine survey. Your Gates representatives are experts in the products they market and provide a variety of in-house and on-site training programs. Nobody is as committed to supporting you as Gates!

It's obvious! Gates is your total synchronous drive solution. With industry-leading technologies, a complete line of high quality, top-performing products, and unmatched customer support, it's easy to see that Gates is the partner to choose in meeting all your needs for synchronous belt drive systems.



▲ Design Flex II™

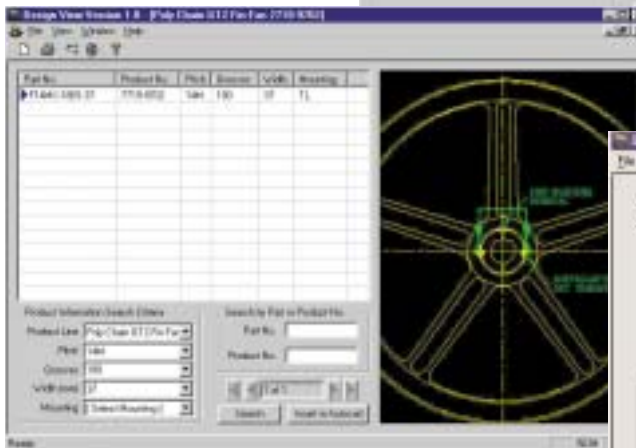

▲ Design View™



Design OHL™ ▶

PowerGrip GT2

The new PowerGrip GT2 drive system combines an innovative rubber compound with Gates' industry-leading belt engineering technology. The result is a belt that provides extraordinary load-carrying capacity in high-speed applications (above 500 rpm). It transmits up to 200% more power than previous PowerGrip GT, PowerGrip HTD® or other first generation curvilinear synchronous belts. Because of the increase in horsepower, size for size, PowerGrip GT2 allows for the design of belt drive systems that are small and compact.

With over 42,000 possible drive combinations available, there's no need to over-design your drives. And with Gates as your system supplier, inventory, transaction and acquisition costs can be significantly reduced.

If you are using PowerGrip GT, PowerGrip HTD or similar curvilinear first generation synchronous belts, you can lower your costs by replacing them with PowerGrip GT2. The increased capacity of Power Grip GT2 allows the use of the next narrower belt size than the current size with no sacrifice in service life.

Whether it's a new or existing application, the PowerGrip GT2 belt is the only belt you need for your high-speed drive applications.

PowerGrip GT2 Construction Features

- 1. Tensile cord-** A fiberglass tensile member provides high strength, excellent flex life and high resistance to elongation. The fiberglass tensile member provides greater length stability than competitive belts using aramid tensile members.
- 2. Neoprene backing-** Strong neoprene is bonded to the tensile member for protection against grime, grease, oil and moisture. It also protects from frictional wear if idlers are used on the back of the belt.
- 3. Neoprene teeth-** High-strength neoprene compound is molded integrally with the neoprene backing. The teeth are precisely formed and precision-spaced to assure smooth meshing with the sprocket grooves, minimizing tooth interference with the mating sprocket. Minimizing tooth meshing interference greatly increases belt life by preventing tooth wear and distortion. Audible drive noise is also minimized.
- 4. Nylon facing-** Tough nylon fabric with a low coefficient of friction covers the wearing surfaces of the belt. It protects the tooth surfaces and provides a durable wear surface for long service life.



Advantages of the Gates PowerGrip GT2 drive system:

PowerGrip GT2 drives provide positive, trouble-free power transmission and offer many advantages over conventional gears and rubber belt drives.

- *Higher capacity*
- *Improved registration*
- *Reduced noise*
- *No lubrication required*
- *No stretching due to wear*
- *Corrosion resistance*
- *Excellent abrasion resistance*
- *Clean operation*
- *Long trouble-free service*
- *Low vibration*

The profile fit.

PowerGrip GT2 belts and sprockets were specially designed to work together as a system in providing the best possible performance.

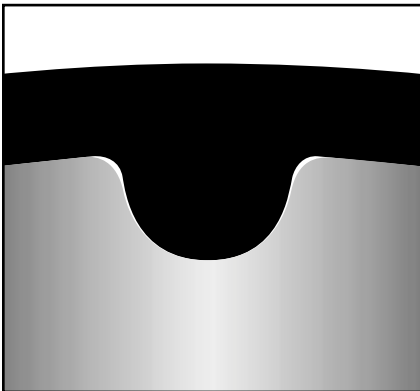

The belt teeth have a deep design for robustness and excellent ratcheting resistance, yet enter and exit the sprocket grooves cleanly with minimal interference. This results in minimal wear and low noise.

The key to the PowerGrip GT2 system is the fit of the belt teeth in the sprocket grooves. The flank

contact area of the belt teeth has been increased significantly over other curvilinear belt drive systems. This greatly increases surface contact area and prevents belt tooth distortion in the sprocket grooves under heavy torque loads. This results in long, trouble-free service. The belt tooth and sprocket groove curvatures were also designed to fit closely together with a minimum of backlash. This means more accurate positioning and less lost motion than in other belt drive systems.

Precision registration.

PowerGrip GT2 drive systems provide timing and synchronization accuracy that make for excellent registration. They are ideal for applications where precision is critical, such as robotics, conveyors and machine tools. Gates offers belts in a full range of standard configurations. Custom-built constructions are also available for individual applications that require maximum performance.

Quiet operation.

The PowerGrip GT2 belt's specially engineered teeth mesh cleanly with sprocket grooves to reduce noise and vibration. Clean meshing results in significant noise reduction when compared to PowerGrip Timing, PowerGrip HTD and some other rubber belts. PowerGrip GT2's high load capacity also allows narrower drive designs, further reducing noise.

The operating noise reduction in comparison with first generation curvilinear tooth belts is remarkable. PowerGrip GT2 belts are made to work hard, yet quietly. Whether or not an application requires low noise levels, PowerGrip GT2 belts deliver a quieter, longer running life—with no sacrifice in performance.

Taper-Lock®

sprockets & bushings.

PowerGrip GT2 belt drive systems feature a new line of sprockets that have been specially designed to handle the new increased belt power ratings. These sprockets utilize Taper-Lock bushings, a bushing system with an industry-proven track record of robustness and reliability.

Taper-Lock bushings allow easy sprocket installation and removal. Their compact design allows narrow sprocket hubs for compact drive systems. They assure secure sprocket mounting and run true, eliminating any concern for reliable operation at both low and high speeds.



The bottom line:

Compared to other rubber belt drive systems, PowerGrip GT2 drives offer you:

- A smaller, more compact design
- Lowest cost drive system for high speed applications
- Longest life, width for width
- More belt and sprocket combinations to choose from
- Easier installation and removal

PowerGrip GT2 Energy Savings Calculator. The sample calculator here illustrates the energy savings of a PowerGrip GT2 drive system. This energy savings program is available exclusively on the Gates Compass PT CD-ROM (version 2.0). Use it to estimate energy savings of a PowerGrip GT2 drive system in your application. For more information on Compass and Gates' Design Flex II drive design program, contact your local Gates representative.

Gates PowerGrip GT2 belts are protected by U.S. patents 4,605,389, 4,403,979, 4,662,863, 5,362,281 and U.S. and foreign patents pending.

INDUSTRIAL BELT DRIVE DESIGN - Energy Report <small>Using Design Flex™II by the Gates Rubber Company</small>				
For:		From: Gates Rubber Company 900 So. Broadway Denver, Colorado 80217-5887 303 - 744 - 5800		
Application: ENERGY SAVINGS - 50 HP				
I N P U T	Motor HP: 50.00			
	RPM: 1750			
	Motor Efficiency: 0.90%			
	Hours Per Day: 24			
	Days Per Week: 7			
	Weeks Per Year: 50			
	¢/KWh: 8.00			
D R I V E S	S-Belt PartNo: 2600-8MGT-50	Price \$ 102.80	V-Belt Part No: 4 / 5VX1000 Price \$ 73.30	
	DriveR Sprocket: P72-8MGT-50	\$ 120.94	DriveR Sheave: QD4/SV7.10 \$ 90.05	
	DriveR Bushing: 2517 2.1/8	\$ 13.85	DriveR Bushing: SF 2.1/8 \$ 18.57	
	DriveN Sprocket: P112-8MGT-50	\$ 187.88	DriveN Sheave: TL4/SV10.30 \$ 128.64	
	DriveN Bushing: 3020 2.1/8	\$ 20.82	DriveN Bushing: 3020 2.1/8 \$ 20.82	
	Total Cost: \$ 446.29		TotalCost: \$ 331.38	
	R E S U L T S	KWh Per Year: 348133 KWH/yr.		
Energy Savings: \$ 1392.53 /yr.				
Cost of Replacing Existing V-Belt Drive				
Where Existing Drive is Operational:		\$ 446.29	Payback Period: 4 months.	
Where V-Belt Needs Replacement:		\$ 372.99	Payback Period: 3 months.	
Where Entire Drive Needs Replacement:	\$ 114.91	Payback Period: 1 months.		
NOTES				
<small>Drive Design by Design Flex II. KWh Per Year are calculated using the following formula: (Motor HP) x (0.746) x (Hours/Year) / (Motor Efficiency) Energy Savings are calculated using the following formula: (KWh Cost) x (KWh Per Year) x 0.05</small>				

PowerGrip GT2 drive systems provide the lowest initial cost compared to any other high-speed rubber belt synchronous system. *And here's proof!*

■ PowerGrip® GT®2
 ■ PowerGrip® GT®
 ■ Goodyear® Eagle Pd®
 ■ RPP® Plus®
 ■ HTD®
 ■ Dayco® Panther®

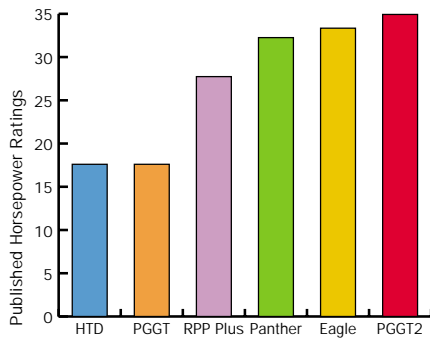

Published Horsepower Ratings
 (8mm Pitch, 56 Groove Sprocket,
 1750 rpm Motor Speed, 1" Belt Width)

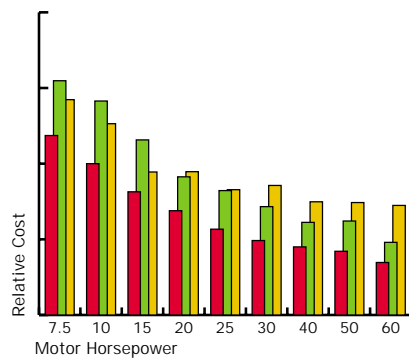

Relative Drive Cost For Motor Horsepowers
 (1750 rpm Motor Speed, 8mm Pitch)

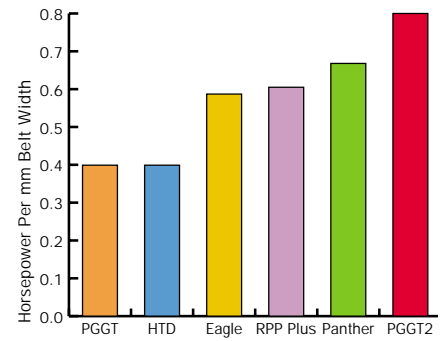

Horsepower Capacity Per mm Belt Width
 (8mm Pitch, 56 Groove Sprocket, 1750 rpm
 Motor Speed, Service Factor Added)

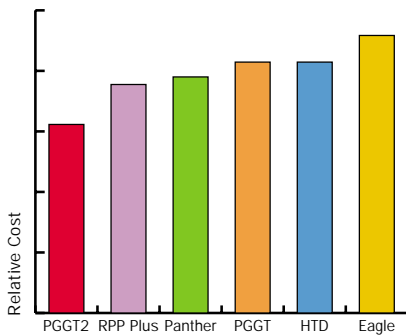

Relative Drive Cost Per Motor Horsepower
 (8mm Pitch, 56 Groove Sprocket, 1750 rpm
 Motor Speed, Service Factor Added)

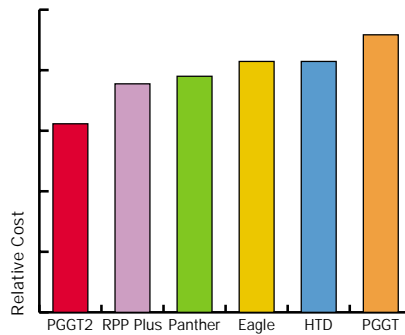

Relative Drive Cost Per Inch of Belt Width
 (8mm Pitch, 56 Groove Sprocket,
 1750 rpm Motor Speed)

8mm Pitch Product Line Comparison

	Gates PowerGrip GT2	Goodyear Eagle Pd	Dayco RPP Panther
Sprocket Diameters	19	26	20
Center Distance Range	3.46 – 83.15	5.51 – 44.09	3.78 – 83.15
Maximum Speed Ratio	6.545:1	11.200:1	8.730:1
Belt Length Selections	33	14	26
Belt Length Range	384 – 4400mm	640 – 2400mm	480 – 4400mm
Belt Width Selections	20-30-50-85	16-32	12-22-35-60
Total Drive Combinations	20000+	7000+	16500+

®™ Eagle PD is a trademark of The Goodyear Tire & Rubber Company. Dayco and Panther are registered trademarks and RPP is a trademark of Dayco Products Inc.

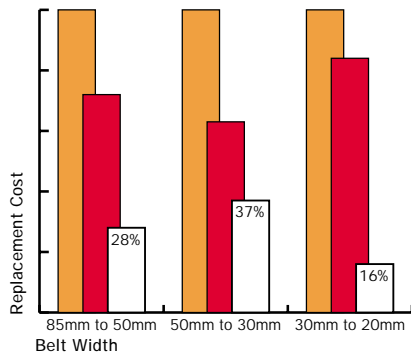

Replacement Belt Cost Saving %
(HTD & PowerGrip GT to PowerGrip GT2,
8mm Pitch)

Design Performance Grouping - PowerGrip GT2				
PowerGrip GT2 - 8 & 14mm Belts can be used to replace other non-Gates curvilinear belts in the next smallest width				
Company	Product Trade Name	Nomenclature	Belt-Pitch	Profile
Bando	Synchro-Link® - HT	1600-8M-20-H	8 & 14mm	HTD
Dodge	HT100™	1600-8M-20 HT100	8 & 14mm	GT
Electron	EHT®	1600-8M-20	8 & 14mm	HTD
Gates	HTD®	1600-8M-20	8 & 14mm	HTD
Jason	HTB®	1600-8M-20	8 & 14mm	HTD
MBL	HTT™	1600-8M-20	8 & 14mm	HTD
Opti Belt	HTD®	1600-8M-20	8 & 14mm	HTD
Browning	HPT®	1600-8M-20	14mm	RPP
Dayco	RPP®	1600-8M-20	14mm	RPP
Goodyear	HPPD™	1600-8M-20	14mm	RPP
T.B. Woods	RPP®	1600-8M-20	14mm	RPP
Thermoid	Synchro-Curve® Timing	1600-8M-20	14mm	RPP
Dayco	RPP Plus™	1600-8M-20	14mm	RPP
Dayco	HPR™	1600-8M-20	14mm	RPP
Dodge	HT150™	1600-8M-20	8 & 14mm	GT
T.B. Woods	RPP Plus™	1600-8M-20	14mm	RPP
T.B. Woods	HPR™	1600-8M-20	14mm	RPP

Competitors Width 8mm - Pitch	PowerGrip GT2 - Width 8mm - Pitch	Competitors Width 14mm - Pitch	PowerGrip GT2 - Width 14mm - Pitch
20	20	40	40
30	20	55	40
50	30	85	55
85	50	115	85
		170	115

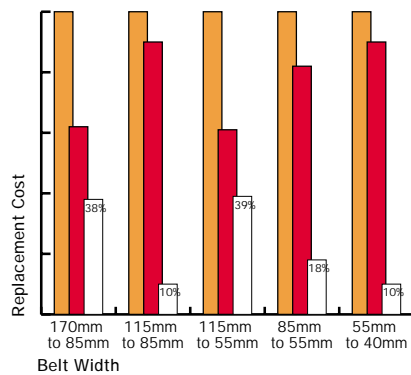

Replacement Belt Cost Saving %
(HTD & PowerGrip GT to PowerGrip GT2,
14mm Pitch)

Design Performance Grouping - PowerGrip GT				
PowerGrip GT - 8 & 14mm Belts can be used to replace other non-Gates curvilinear belts in the same width				
Company	Product Trade Name	Nomenclature	Belt-Pitch	Profile
Bando	Synchro-Link® - HT	1600-8M-20-H	8 & 14mm	HTD
Dodge	HT100™	1600-8M-20 HT100	8 & 14mm	GT
Electron	EHT®	1600-8M-20	8 & 14mm	HTD
Gates	HTD®	1600-8M-20	8 & 14mm	HTD
Jason	HTB®	1600-8M-20	8 & 14mm	HTD
MBL	HTT™	1600-8M-20	8 & 14mm	HTD
Opti Belt	HTD®	1600-8M-20	8 & 14mm	HTD
Browning	HPT®	1600-8M-20	14mm	RPP
Dayco	RPP®	1600-8M-20	14mm	RPP
Goodyear	HPPD™	1600-8M-20	14mm	RPP
T.B. Woods	RPP®	1600-8M-20	14mm	RPP
Thermoid	Synchro-Curve® Timing	1600-8M-20	14mm	RPP

14mm Pitch Product Line Comparison

	Gates PowerGrip GT2	Goodyear Eagle Pd	Dayco RPP Panther
Sprocket Diameters	23	21	23
Center Distance Range	7.99 - 127.32	8.54 - 47.40	7.99 - 89.84
Maximum Speed Ratio	6.857:1	6.00:1	7.71:1
Belt Length Selections	22	14	18
Belt Length Range	966 - 6860mm	994 - 2800mm	966 - 4956mm
Belt Width Selections	40-55-85-115-170	35-53-70-105	20-42-65-90-120
Total Drive Combinations	22000	8,000+	17,500+

Make the switch to PowerGrip GT2.

PowerGrip GT2 drives will provide greater horsepower capacity at less cost than any other synchronous belt drive system in a wide variety of industry applications including:

Lumber, Pulp & Paper

Conveyors, repulpers, sentry screens, effluent systems, presses, waxers, chippers, debarkers, slashers, chip 'n saws, edgers, roll grinders, screw conveyors, flotation cells, cut-off saws, hourglass rolls, dryers, agitators, calendars, pumps, winders



Food Processing

Pumps, bucket elevators, belt conveyors, icing machines, elongators, dough mixers, cookers, mills, bottling machines, meat grinders, hog dehairers

Packaging

Box makers, carton sealers, case palletizers, and live roll, apron, belt, chain and screw conveyors

Aluminum/Steel

Bucket elevators, shot blasters, conveyor drives, scrap cutters, sand seals, drag-out machines, polishers, cooling chambers, muffler furnaces, mandrel stripping rods, spinner cars, gray iron foundries, sand conveyors, bucket elevators, grinders

Petrochemical Industries

Air coolers, fin fans, chlorine compressors, processing, centrifuges, dryers, compressors, pumps

Sand, Gravel & Concrete

Feeder drives, conveyor drives, elevators, screw conveyors

Glass

Manufacturing / Bottles

Conveyors, crushers, grinders, carton sealers, case palletizers

HVAC

Air blower fan drives, ventilating fans, exhaust fans

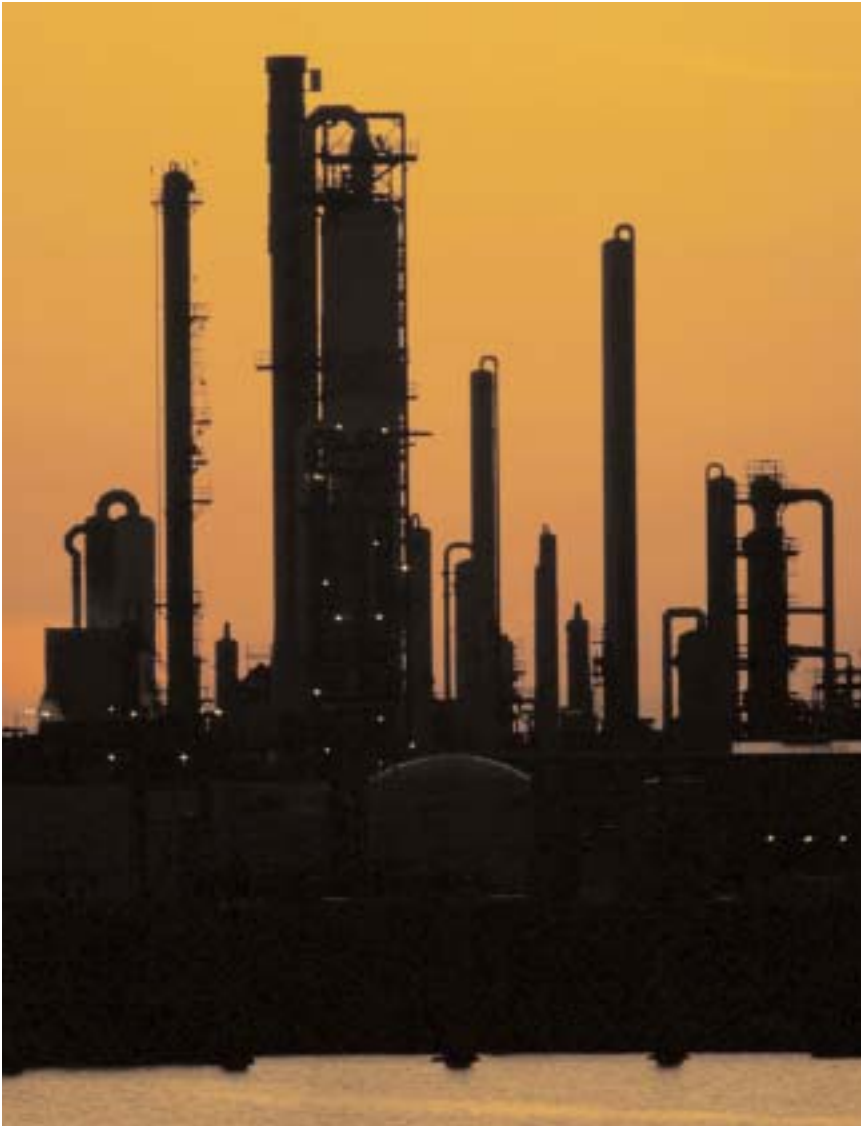

WARNING! Be Safe! Gates belt drive systems are very reliable when used safely and within Gates application recommendations. However, there are specific USES THAT MUST BE AVOIDED due to the risk of serious injury or death. These prohibited mis-uses include:

Primary In-Flight Aircraft Systems

Do not use Gates belts, pulleys or sprockets on aircraft, propeller or rotor drive systems or in-flight accessory drives. Gates belt drive systems are not intended for aircraft use.

Lift Systems

Do not use Gates belts, pulleys or sprockets in applications that depend solely upon the belt to raise/lower, support or sustain a mass without an independent safety backup system. Gates belt drive systems are not intended for use in applications requiring special "Lift" or "Proof" type chains with minimum tensile strength or certified/test tensile strength requirements.

Braking Systems

Do not use Gates belts, pulleys or sprockets in applications that depend solely upon the belt to slow or stop a mass, or to act as a brake without an independent safety backup system. Gates belt drive systems are not intended to function as a braking device in "emergency stop" systems.

There's nothing like a good set of teeth when it comes to synchronous belts.

The advantages of Gates PowerGrip GT2 belt drives are overwhelming

The PowerGrip GT2 Belt Drive System is an advance in product design over Gates older, standard HTD system. The PowerGrip GT2 System, featuring a modified curvilinear belt tooth profile, provides timing and indexing accuracy equivalent to the conventional PowerGrip Trapezoidal Belt System. Plus, PowerGrip GT2 Belts have a higher capacity and longer belt life than trapezoidal belts.

It's difficult to make a true quantitative comparison between the backlash of a trapezoidal tooth drive and PowerGrip GT2 tooth drive due to the difference in "sprocket to belt tooth" fit. (See illustrations below). Trapezoidal belts contact the sprocket in the root radius— upper flank area only, while the PowerGrip GT2 system permits full flank contact.

The main stress line in a trapezoidal tooth timing belt is at the base of the teeth. During operation this stress greatly reduces belt life. The PowerGrip GT2 system overcomes this condition with its complete tooth flank contact which eliminates the tooth stress line area. This greatly increases belt life and prevents tooth distortion caused by drive torque. In addition, the conventional timing belt has a chordal effect as it wraps small sprockets. This is significantly reduced in the PowerGrip GT2 system because there's full tooth support along the sprocket. Full support improves meshing, reduces vibration and minimizes tooth deformation.

On drives using a low installation tension, small pulleys, and light loads, the backlash of the PowerGrip GT2 system will be slightly better than the trapezoidal timing belt system. However, with increased tension and/or loads and/or sprocket sizes the performance of the PowerGrip GT2 system becomes significantly better than the trapezoidal timing belt system.

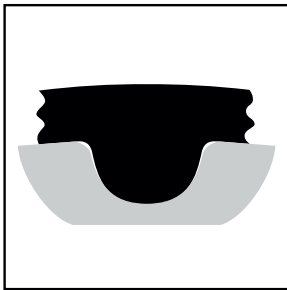

**PowerGrip® GT² Belt
Tooth/Groove Contact**

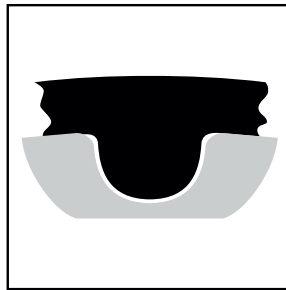

**PowerGrip® HTD® Belt
Tooth/Groove Contact**

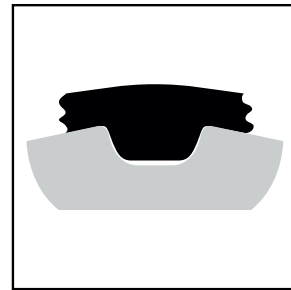

**PowerGrip® Timing Belt
Tooth/Groove Contact**

The PowerGrip GT2 system is an extension of the HTD system with improved load-carrying capacity. HTD was developed for high torque drive applications, but is not acceptable for most precision indexing or registration applications. The HTD design requires substantial belt tooth to sprocket groove clearance (backlash) to perform. As smaller diameter sprockets are used, the clearance required to operate properly is increased. HTD drive clearance, using small diameter sprockets, is approximately four times greater than than an equivalent timing belt drive.

Deep tooth profile makes the difference

The PowerGrip GT2 system's deep tooth design increases the contact area which provides improved resistance to ratcheting. The modified curvilinear teeth enter and exit the sprocket grooves cleanly resulting in reduced vibration. This tooth profile design results in parallel contact with the groove and eliminates stress concentrations and tooth deformation under load. The PowerGrip GT2 design improves registration characteristics and maintains high torque carrying capability.

Introduction — PowerGrip® GT² Belt Drives

The choice of the industry for ultimate durability and precision

The Gates PowerGrip GT2 combines the very best in technology and construction design to give improved performance and extended product life.

Last longer than competitive belts

The PowerGrip GT2 belt has been tested against the competition, under equivalent conditions, at speeds up to 9,000 RPM. It outlasted the competition more than two to one. Strong fiberglass tensile cords wrapped in a durable neoprene body gives it flexibility and increases service life. A deep tooth profile provides superior load-carrying strength and greatly reduces ratcheting when used with Gates designed sprockets.

Precision registration

PowerGrip GT2 Belt Drive Systems provide timing and synchronization accuracy that make for flawless registration, with no loss of torque carrying capability.

Increases load-carrying capacity

Performance far exceeds HTD and trapezoidal belt capabilities making PowerGrip GT2 belts the choice



for accurate registration, heavy loads and small sprockets.

Sounds this quiet.....

The PowerGrip GT2 belt's specially engineered teeth mesh cleanly with sprocket grooves to reduce noise and vibration. Clean meshing results in significant noise reduction when compared to PowerGrip Timing and HTD belts.

When precision is critical, depend on PowerGrip GT2 belts

PowerGrip GT2 belts are specifically designed for applications where precision is critical. Applications such as robotics, conveyors and machine tools. We offer belts in a variety of sizes... custom built constructions are also available for individual applications that require maximum performance. Gates worldwide manufacturing capabilities assures you of prompt service for important markets.

PowerGrip GT2 belts are currently available in 5mm, 8mm, 14mm and 20mm pitches.

See Pages 7-58 for PowerGrip GT2 Belt Drives.

Here are just some of the many applications of PowerGrip GT2 belts:

- machine tools
- hand power tools
- DC stepper/servo applications
- pumps
- floor care equipment
- medical diagnostic equipment
- centrifuges
- fans
- robotics equipment
- vending equipment
- conveyors
- compressors



Introduction — PowerGrip® Timing Belt Drives

Provide positive, non-slip power transmission

PowerGrip Timing Belts are a good standard line product with a history of reliability. Around since the late 1940's, this product line has been the flagship of synchronous power transmission prior to Gates introduction of PowerGrip HTD and GT2 Belts.



Gates timing belts are made with a true design pitch, a standard of the Rubber Manufacturers' Association and the International Standards Organization.

PowerGrip Timing Belts are recommended for these types of applications:

- office equipment
- appliances
- medical equipment
- data processing equipment
- power tools
- robotics
- spindles
- mailing equipment

See pages 59-84 for PowerGrip Timing Drives.

Introduction — PowerGrip® Twin Power® Belt Drives

Dual driving surfaces allow for unique, problem solving drive designs

Gates Twin Power Belts have teeth on both sides to provide synchronization from both driving surfaces. This special feature makes possible unique drive designs such as multipoint drives, rotation reversal with one belt, serpentine drives, etc. They may also provide solutions to other difficult design problems.



Twin Power Belts are similar in construction to regular synchronous belts, including nylon-faced teeth on both sides.

NOTE: Twin Power Belts are available in GT2 and Timing Belt configurations, so designers can use them in a wide variety of applications.

Some typical PowerGrip Twin Power applications are:

- serpentine drives
- reversing rotations

See pages 95-99 for PowerGrip Twin Power Belting.

Introduction — PowerGrip® Long Length Belting

For drives that require belt lengths longer than can be produced in conventional endless form.

Long-length PowerGrip Belting has the same basic construction as conventional Gates synchronous belts.

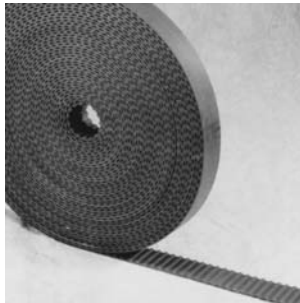

For information or assistance on any long length belt problem, contact Gates Application Engineering.

NOTE: Long-length PowerGrip Belting is available in GT, HTD, Timing Belt and Synchro-Power Polyurethane configurations.

Typical PowerGrip Long Length Belting uses are:

- reciprocating carriage drives
- rack and pinion drives
- large plotters

See pages 85-94 for PowerGrip Long Length Belting.



PowerGrip® GT² Belt Drives

The operating noise comparison with first generation curvilinear tooth belts is remarkable. PowerGrip GT2 belts are made to do the work quietly. Whether or not an application requires low noise levels, PowerGrip GT2 belts give quieter, longer running life—with no sacrifice in performance like other competitive belts.

Using a multmillion-dollar manufacturing process that features breakthrough belt building technology, Gates assures each belt meets the highest standards of precision construction.

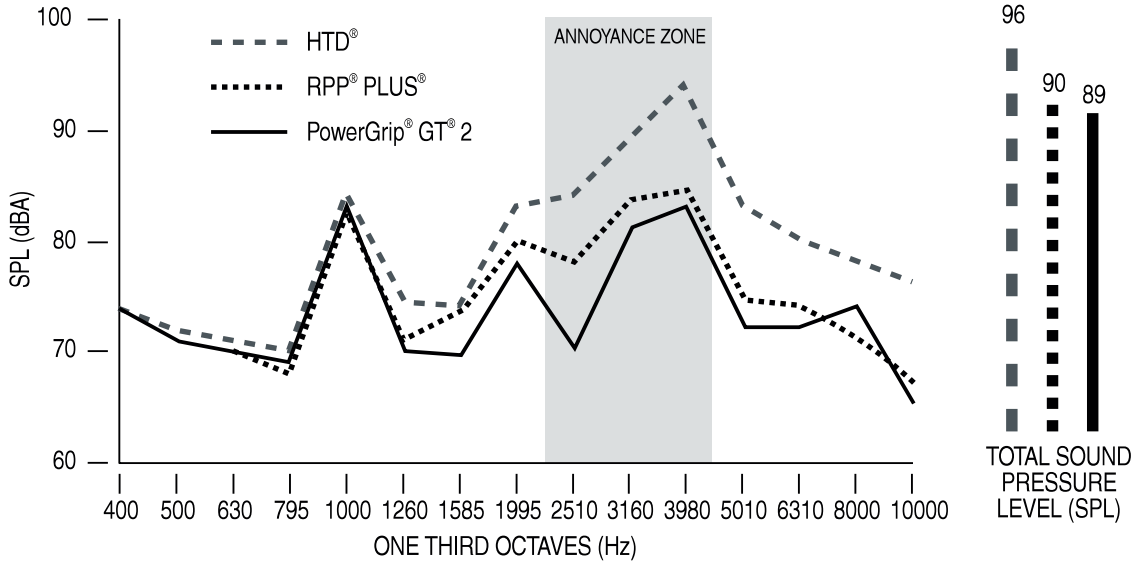

Test Conditions

Belt	Length	1400mm
	Width	40mm
Sprockets	DriveR	36 Grooves
	DriveN	36 Grooves
Load		36 HP
Speed		1750 rpm

All tests in HTD Sprockets

Please note the “Annoyance Zone” in the graph above. This zone, roughly 2,000-4,000 Hz, is the frequency range to which the human ear is the most sensitive. The PowerGrip GT2 belt has an obvious advantage in this zone. Also note the Total Sound Pressure Level (SPL) depicted in the adjoining bar graph. Here again, the overall noise level (SPL) is dramatically lower for the PowerGrip GT2 belt.



Belt Construction

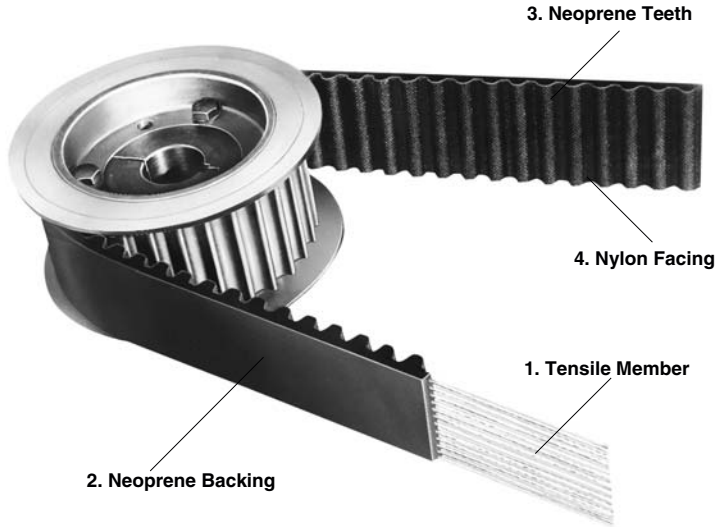

PowerGrip GT2 drives provide positive, trouble-free power transmission in low speed — high torque applications and offer many advantages over conventional chain, gear and other belt drives.

Advantages:

- Higher capacity
- Improved registration
- Reduced noise
- No lubrication required
- No stretching due to wear
- Corrosion resistance
- Excellent abrasion resistance
- Clean operation
- Long trouble-free service



Construction Features

The tooth design substantially improves stress distribution and allows extra high loading. The molded teeth enter and leave the sprocket grooves smoothly with negligible friction — functioning in much the same way as teeth on a gear.

Construction consists of these components:

1. **Tensile Member** — Provides high strength, excellent flex life and high resistance to elongation.
2. **Neoprene Backing** — Strong Neoprene bonded to the tensile member for protection against grime, oil and moisture. It also protects from frictional wear if idlers are used on the back of the belt.
3. **Neoprene Teeth** — Shear-resistant Neoprene compound is molded integrally with the Neoprene backing. They are precisely formed and accurately spaced to assure smooth meshing with the sprocket grooves.
4. **Nylon Facing** — Tough nylon fabric with a low coefficient of friction covers the wearing surfaces of the belt. It protects the tooth surfaces and provides a durable wearing surface for long service.

PowerGrip® Belt Drive Selection Procedure

Selection of a stock PowerGrip Belt Drive System involves these five steps:

1. Calculate design horsepower.
2. Select belt pitch
3. Select sprockets and belt.
4. Select belt width.
5. Determine bushing and bore requirements.

Sample Problem

A gear pump is to be driven by a 30 hp normal torque electric motor with an output speed of 1160 rpm. The gear pump is to be driven at 580 rpm $\pm 5\%$. The center distance is to be approximately 30 inches, but can be altered ± 3 inches, if necessary. The motor shaft is $2\frac{3}{8}$ inches and the pump shaft is 3 inches. The pump will operate 16 hours a day, five days a week. The pump sprocket is limited to 18 inches OD. There are no unusual drive conditions. Design using PowerGrip GT2.

Step 1 Determine Design Horsepower

Procedure

To calculate the design hp, first determine the relative severity or service factor of the drive. Average hours per day of service also should be considered. Locate the power source and the driveN unit in the Service Factors table on Page 15. The design hp then is determined by multiplying the rated hp (usually the nameplate rating) by the service factor determined above.

Example

Using the Service Factor Chart, the driveR would be found in the first group. Since the pump will run 16 hours per day, follow the continuous service column down to the driveN machines group for gear pumps. This gives a 1.7 Service Factor. Since this is not a low speed or speedup drive, no additional service factor is required.

$$\text{Design HP} = 30 \times 1.7 = 51\text{DHP}$$

Step 2 Select Belt Pitch

Procedure

Using the design hp and the rpm of the faster shaft, select from Belt Pitch Selection Guide graph on Page 11.

Example

Locate 1160 rpm on the RPM of Faster Shaft scale and move over to where the Design Horsepower of 51 Dhp line intersects. The intersection falls at the 8mm and 14mm pitch overlap area. Both 8mm and 14mm pitches should be considered.

Step 3 Select Sprockets and Belt Length

Procedure

a. Determine speed ratio.

The speed ratio can be determined by dividing the rpm of the faster shaft by the slower shaft rpm.

Example

$$\frac{\text{rpm of faster shaft}}{\text{rpm of slower shaft}} = \frac{1160}{580} = 2.0$$

b. Select sprocket combination and belt length. Turn to the Stock Drive Selection Tables (pages 16 through 43, 52 through 55 and 61 through 74) and in the proper pitch tables find the chosen speed ratio. Moving over within the speed ratio block, find the stock sprocket combinations available for that speed ratio. Selection of the proper combination will depend on the center distance required, minimum or maximum required sprocket diameter and the recommended minimum sprocket diameter for electric motors (See table on Page 12).

After selecting possible sprocket combinations and center distances, record belt length (top of column) Length Factor (bottom of column), and the Teeth In Mesh Factor if applicable.

Example

First, using the Stock Drive Selection Tables for 8mm pitch belts on pages 30 through 35, we locate the speed ratio of 2.0 to 1 on pages 32 and 33. The various sprocket combinations with a center distance within the required tolerance range is 8. Of these, three are closest to the desired 30 inches. These are 72 to 144, 56 to 112 and 40 to 80. The minimum sprocket diameter of 6.1 inches for a 30 hp motor at 1160 rpm (See table on Page 12) eliminates the 56 to 112 and 40 to 80 sprocket combinations. Only the 8mm pitch, 72 to 144 sprocket combination will be considered further. On the line for the 72 to 144 sprocket combination, the center distance of 30.02 inches uses a 2400mm (94.49-inch), 8mm pitch belt. The belt length factor is 1.2.

Secondly, using the Stock Drive Selection Tables for 14mm pitch belts on pages 36 through 43, locate the speed ratio of 2.0 to 1 on page 40. Several combinations are shown which will meet the 30 ± 3 -inch center distance requirement. The maximum OD limit of 18 inches on the driveN sprocket eliminates two of the combinations and the preference for as close to 30 inches center distance would favor the 36 to 72 and 28 to 56 combinations. However, the 4.912-inch diameter of the 28-groove sprocket is less than the recommended minimum diameter of 6.1 inches for the electric motor. So the 36 to 72 sprocket combination is chosen for further consideration.

For the 36 to 72, 14-mm pitch sprocket combination, the belt length used for the 30.42-inch center distance is a 2310mm (90.94-inch), 14mm pitch belt. The belt length factor is 1.0.

continued

Procedure

c. Check belt speed.

Do not exceed 6500 fpm with stock sprockets. Belt Speed is determined using the following formula:

$$V(\text{fpm}) = \frac{\text{PD (inches)} \times \text{Speed (rpm)}}{3.82}$$

Example

Determining belt speed for each of the drive systems shows that the belt speed does not exceed 6500 fpm and can be considered further.

8mm Drive:

$$V = \frac{7.218 \times 1160}{3.82} = 2191.9 \text{ fpm}$$

14mm Drive:

$$V = \frac{6.316 \times 1160}{3.82} = 1917.9 \text{ fpm}$$

Step 4 Select Belt Width

Procedure

Belt Width Selection Tables (pages 44 through 51, 56 through 58 and pages 75 through 84) show the horsepower ranges of stock belt widths. The left-hand column shows the speed of the smaller sprocket. Across the top are various stock sprockets. The base rated horsepower capacity of a given sprocket at a specific rpm is at the point of intersection of the rpm row and sprocket column.

This base horsepower rating must be corrected for the belt length selected and for the number of teeth in mesh (if less than 6). Multiply the base table rating by the applicable Length Factor and Teeth In Mesh Factor (if applicable), both determined in Step 3b. The corrected horsepower rating must equal or exceed design hp.

Where there are several choices, drive limitations may control the selection. In addition, the following rules must be observed.

1. Larger sprockets mean less belt width.
2. Larger sprockets yield extra long service life.
3. Avoid drives where the belt width exceeds sprocket diameter.
4. Avoid drives where center distance is greater than 8 times the diameter of the smaller sprocket. Refer to Section II, Drive Alignment on Page 141 for additional details.

Example

Referring to the 8mm pitch Belt Width Selection tables on page 47, locate the 1160 rpm line in each table in turn. Proceeding across to the 72-groove sprocket column (Smaller sprocket groove number), note the base belt horsepower capacity in each table. The 50mm (1.97-inch) width belt has a base horsepower rating which, when multiplied by the length factor of 1.2, exceeds the design horsepower.

$$68.5 \text{ hp} \times 1.2 = 82.2 \text{ hp}$$

And, repeating the procedure for the 14mm pitch belt horsepower tables on pages 49 through 51, we find the 55mm (2.16-inch) width belt has an 77.1 base horsepower rating for a 36-groove sprocket. This, multiplied by the length factor of 1.0, gives a corrected horsepower rating of 77.1 which also exceeds the design horsepower.

Since there is now a choice between the 8mm pitch, 72 to 144 ratio drive components, and the 14mm pitch, 36 to 72 ratio drive components, the rules as given in the procedure column must be considered. Rules 1 and 2 would dictate larger sprockets. Width is unaffected. Rules 3 and 4 would not apply, so the 8mm pitch drive system is the choice.

Step 5 Check and Specify Stock Drive Components

Procedure

a. Check the sprockets selected in steps 3 and 4 against the design requirements using the dimensions given in the Sprocket Specification Tables on pages 100 through 114. Use flange diameter in checking against maximum diameter requirements.

Example

From the table on Page 105, we find the P144-8MGT-50 driveN sprocket has an overall diameter of 14.383 inches which is less than the 18-inch maximum specified.

Procedure

b. Determine the type of bushing and check bore sizes by using the Sprocket Specification Tables; find the bushings to be used with the required sprockets. From the Stock Bushing Tables on pages 119 through 122, check the bore range and keyway dimensions against the design requirements.

Example

Also from the sprocket data on Page 105 we note that the P72-8MGT-50 sprocket takes a 2517 bushing and the P144-8MGT-85 sprocket takes a 3020 bushing. On Page 119 in the bushing data table, a 2517 bushing has a bore range of $\frac{1}{2}$ to $2\frac{1}{16}$ inches which includes the $2\frac{1}{8}$ -inch bore required for the driveR shaft. The 3020 bushing has a bore range from $\frac{7}{8}$ to $3\frac{1}{4}$ inches which meets the 3-inch bore required for the driveN shaft.

Procedure

c. Specify stock drive components

Example

They are as follows:

- 1—2400-8MGT-50 PowerGrip GT2 belt
- 1—P72-8MGT-50 driveR sprocket
- 1—2517 Bushing with a $2\frac{1}{8}$ -inch bore
- 1—P144-8MGT-50 driveN sprocket
- 1—3020 Bushing with a 3-inch bore

High Speed Drive Survey and Energy Savings Worksheet

Customer Information

Distributor _____

Customer _____

Drive Information

I.D. of Drive (location, number, etc.) _____

Description of DriveN Equipment _____

Manufacturer of DriveN Equipment _____

Horsepower Rating of Motor _____ DriveN HP Load (Peak) _____ (Normal) _____

Motor Frame Size _____ Motor Shaft Dia. _____ DriveN Shaft Dia. _____

Speed:

DriveR RPM _____ RPM Measured with Contact or Strobe Tachometer Yes No

DriveN RPM _____ RPM Measured with Contact or Strobe Tachometer Yes No

Speed Ratio _____ Speed Up _____ or Speed Down _____

Center Distance: Minimum _____ Nominal _____ Maximum _____

Existing Drive Components: DriveR _____ DriveN _____

Belts _____ Belt Manufacturer _____

Ambient Conditions:

Temperature _____ Moisture _____ Oil, etc. _____

Abrasives _____ Shock Load _____

Static Conductivity Required? Yes No

Maximum Sprocket Diameter (OD) and Width Limitations (for guard clearance):

DriveR: Max. OD _____ Max. Width _____ DriveN: Max. OD _____ Max. Width _____

Guard Description _____

Motor Mount:

Double Screw Base? Yes No Motor Mounted on Sheet Metal? Yes No

Adequate Structure? Yes No Floating/Pivot Motor Base? Yes No

Start Up Load:

%Motor Rating at Start Up _____ AC Inverter? Yes No Soft Start? Yes No

Duty Cycle:

Number of Starts/Stops _____ times per _____ (hour, day, week, etc.)

Energy Savings Information

Energy Cost per KW-Hour _____

Hours of Operation: _____ Hours per Day _____ Days per Week _____ Weeks per Year _____

PowerGrip® Belt Drives

PowerGrip® GT² Belt Pitch Selection Guide

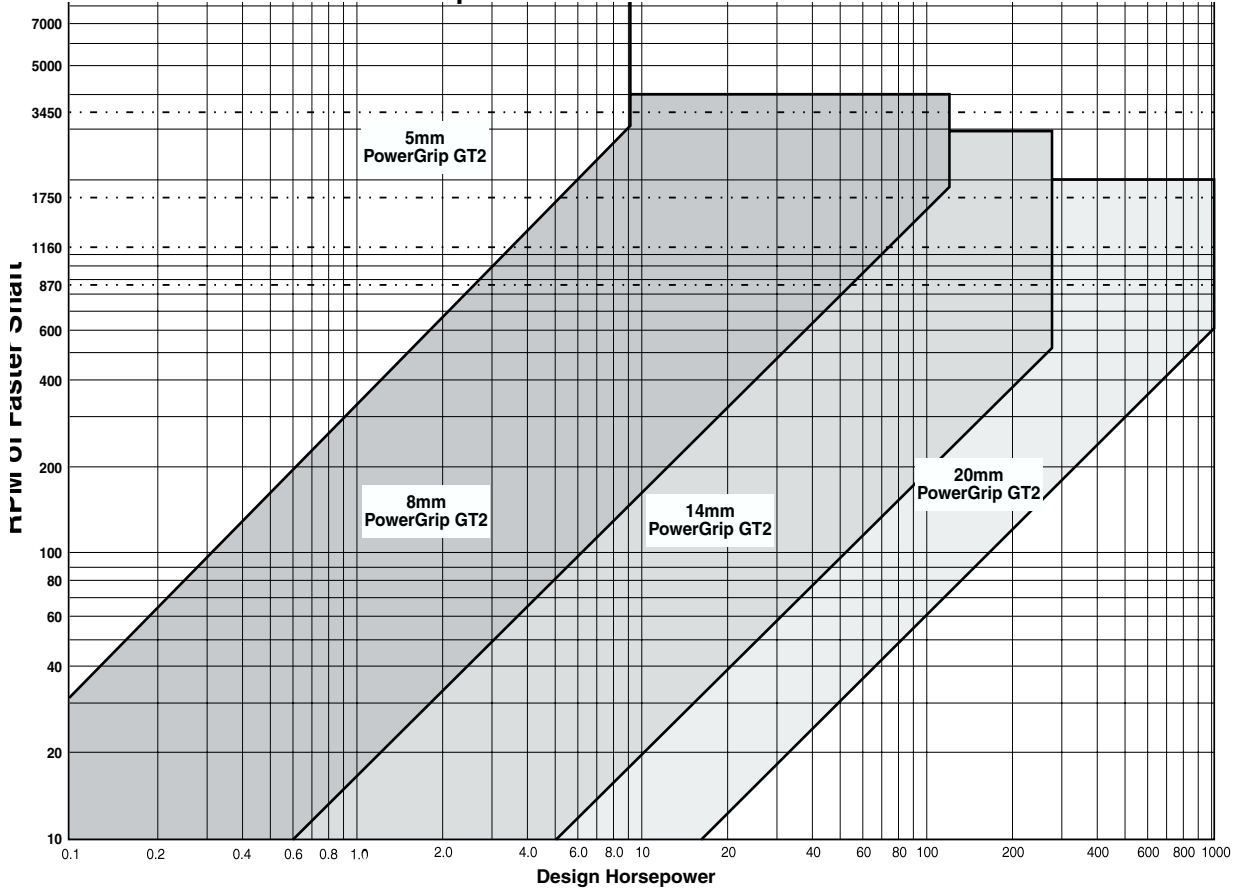

PowerGrip® Timing Belt Pitch Selection Guide

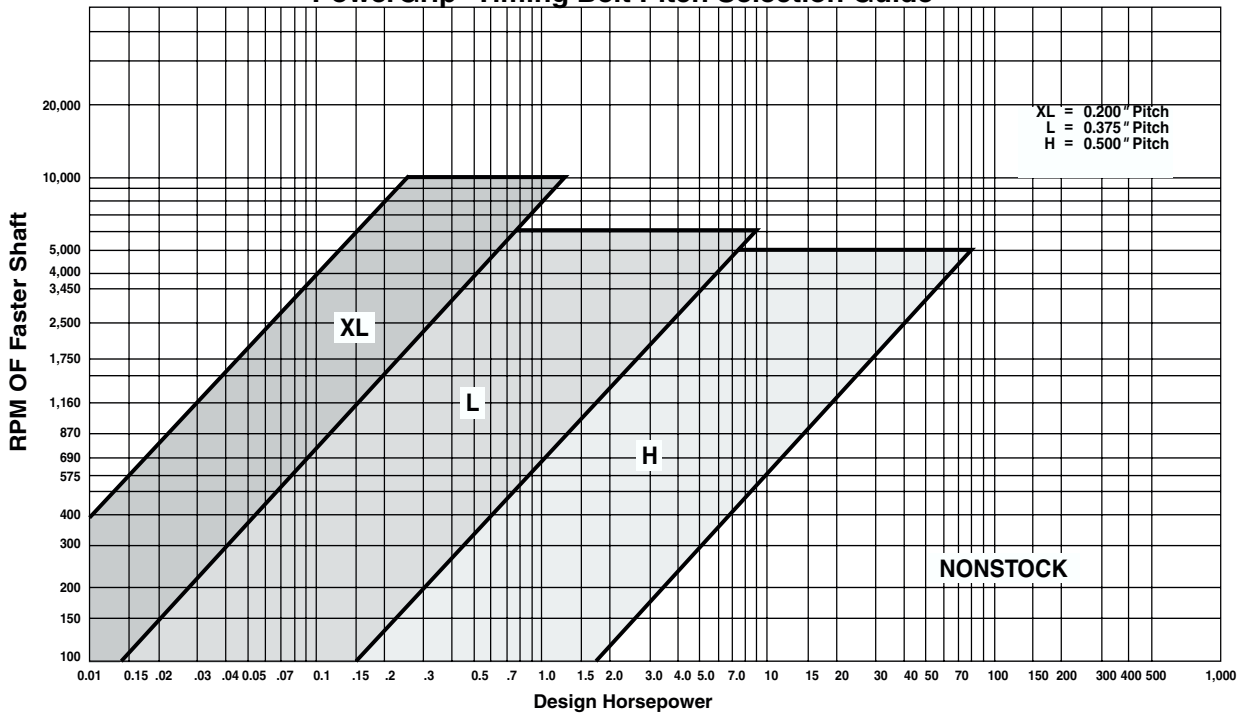

Minimum Recommended Sprocket Outside Diameters for General Purpose Electric Motors — Synchronous Belts

Motor Horsepower	Motor RPM (60 Cycle and 50 Cycle Electric Motors)					
	575 485*	690 575*	870 725*	1160 950*	1750 1425*	3450 2850*
½	—	—	2.0	—	—	—
¾	—	—	2.2	2.0	—	—
1	2.7	2.3	2.2	2.2	2.0	—
1½	2.7	2.7	2.2	2.2	2.2	2.0
2	3.4	2.7	2.7	2.2	2.2	2.2
3	4.1	3.4	2.7	2.7	2.2	2.2
5	4.1	4.1	3.4	2.7	2.7	2.2
7	4.7	4.1	4.0	3.4	2.7	2.7
10	5.4	4.7	4.0	4.0	3.4	2.7
15	6.1	5.4	4.7	4.0	4.0	3.4
20	7.4	6.1	5.4	4.7	4.0	4.0
25	8.1	7.4	6.1	5.4	4.0	4.0
30	9.0	8.1	6.1	6.1	4.7	—
40	9.0	9.0	7.4	6.1	5.4	—
50	9.9	9.0	7.6	7.4	6.1	—
60	10.8	9.9	9.0	7.2	6.7	—
75	12.5	11.7	8.5	9.0	7.7	—
100	16.2	13.5	10.8	9.0	7.7	—
125	18.0	16.2	13.5	10.8	9.5	—
150	19.8	18.0	16.2	11.7	9.5	—
200	19.8	19.8	19.8	—	11.9	—
250	19.8	19.8	—	—	—	—
300	24.3	24.3	—	—	—	—

* These RPM are for 50 cycle electric motors.

Use 8.6 for Frame Number 444 T only.

Data in the white area are from NEMA Standard MG-1-14-42, June, 1972, while data in the light blue area are from MG-1-14-43, January, 1968.

The dark blue area is a composite of electric motor manufacturers data. They are generally conservative, and specific motors and bearings may permit the use of a smaller motor sprocket. Consult the motor manufacturer. See Engineering Section II-13, Bearing/Shaft Load Calculations on Page 142.

NOTE: For a given motor horsepower and speed, the total belt pull is related to the motor sprocket size. As this size **decreases**, the total belt pull **increases**. Therefore, to limit the resultant load on motor shaft and bearings, NEMA lists minimum sprocket sizes for the various motors.

PowerGrip® GT² Belt Drives

Gates 5mm, 8mm, 14mm and 20mm pitch GT2 belts have helically-wound fiberglass tension members embedded in a Neoprene body with the belt teeth faced with a tough wear-resistant nylon fabric.

The three principal dimensions of a belt are

Pitch Pitch Length Width

Belt pitch is the distance in millimeters between two adjacent tooth centers as measured on the pitch line of the belt. Belt pitch length is the total length (circumference) in millimeters as measured along the pitch line. The theoretical pitch line of a PowerGrip GT2 belt lies within the tensile member.

The part number designations for PowerGrip GT2 belts depend on the pitch of the belt. Belt designations are shown below for each of the available pitches.

5mm PowerGrip GT2

Example: 5mm pitch, 1600mm pitch length, 25mm belt width
Belt Designation: 5MR-1600-25

8mm, 14mm PowerGrip GT2

Example: 14mm pitch, 1610mm pitch length, 55mm belt width
Belt Designation: 1610-14MGT-55

20mm PowerGrip GT2

Example: 20mm pitch, 2000mm pitch length, 230mm belt width
Belt Designation: 2000-20M-230

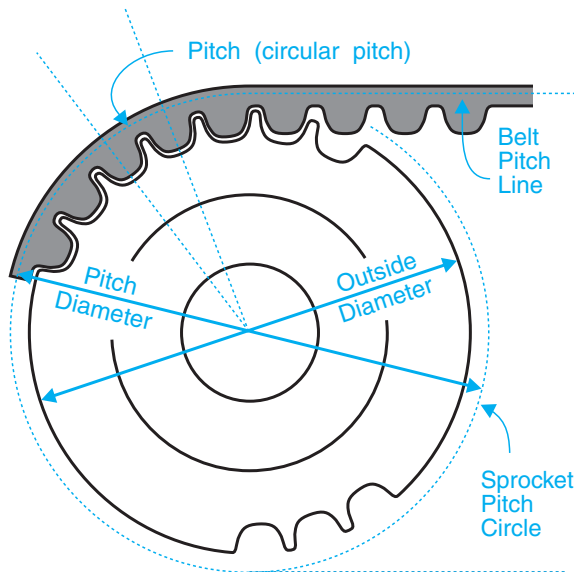

The part number designations for PowerGrip GT2 sprockets depend on the pitch of belt. Sprocket designations are shown below for each of the available pitches.

5mm, 8mm, 14mm PowerGrip GT2

Example: 14mm pitch, 48 grooves, 55mm belt width
Sprocket Designation: P48-14MGT-55

20mm PowerGrip GT2

Example: 20mm pitch, 52 grooves, 230mm belt width
Belt Designation: P52-20M-230

NOTE: 20mm pitch PowerGrip GT2 belts use 20mm pitch HTD sprockets.

5mm Pitch – Reference Dimensions

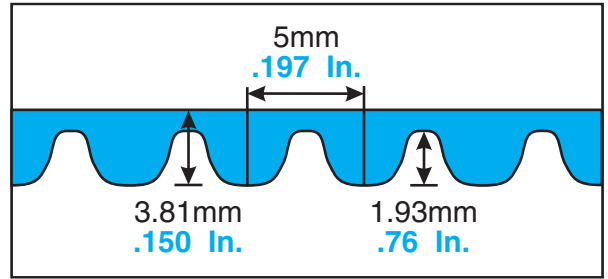

8mm Pitch – Reference Dimensions

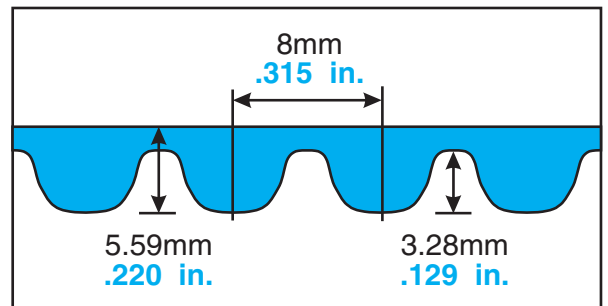

14mm Pitch – Reference Dimensions

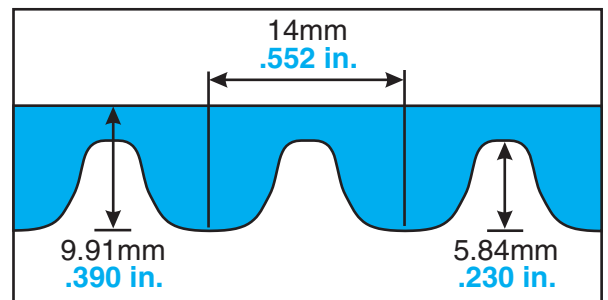

20mm Pitch – Reference Dimensions

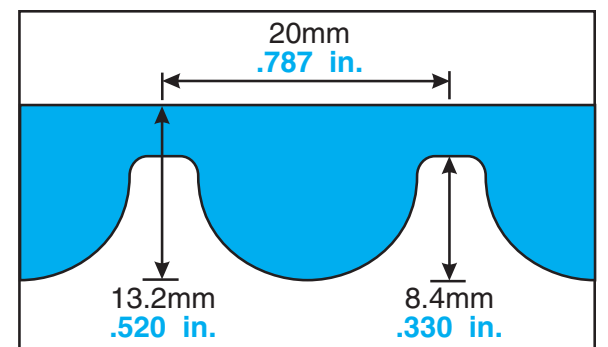

PowerGrip® GT² Belt Drives

The following tables list the stock Industrial Belts and their essential specification.

5mm Pitch PowerGrip GT2 Stock Belt Lengths

Designation	Pitch Length		No. of Teeth
	(mm)	(in)	
5MR-300	300	11.81	60
5MR-355	355	13.98	71
5MR-375	375	14.76	75
5MR-400	400	15.75	80
5MR-425	425	16.73	85
5MR-450	450	17.72	90
5MR-405	405	15.99	81
5MR-500	500	19.69	100
5MR-535	535	21.06	107
5MR-565	565	22.24	113
5MR-580	580	22.83	116
5MR-600	600	23.62	120
5MR-625	625	24.61	125
5MR-650	650	25.59	130
5MR-700	700	27.56	140
5MR-750	750	29.53	150
5MR-800	800	31.50	160
5MR-850	850	33.46	170
5MR-900	900	35.43	180
5MR-1000	1000	39.37	200
5MR-1150	1150	45.28	230
5MR-1300	1300	51.18	260
5MR-1450	1450	57.09	290
5MR-1600	1600	62.99	320
5MR-1720	1720	67.72	344
5MR-2100	2100	82.67	420

5MR Stock Belt Widths

Belt Width Code	Belt Width (mm)	Belt Width (in)
09	9	0.354
15	15	0.591
25	25	0.984

8mm Pitch PowerGrip GT2 Stock Belt Lengths

Designation	Pitch Length		No. of Teeth
	(mm)	(in)	
384-8MGT	384	15.12	48
480-8MGT	480	18.89	60
560-8MGT	560	22.05	70
600-8MGT	600	23.62	75
640-8MGT	640	25.20	80
720-8MGT	720	28.35	90
800-8MGT	800	31.50	100
840-8MGT	840	33.07	105
880-8MGT	880	34.65	110
920-8MGT	920	36.22	115
960-8MGT	960	37.80	120
1040-8MGT	1040	40.94	130
1064-8MGT	1064	41.89	133
1120-8MGT	1120	44.09	140
1160-8MGT	1164	45.67	145
1200-8MGT	1200	47.24	150
1224-8MGT	1224	48.19	153
1280-8MGT	1280	50.39	160
1440-8MGT	1440	56.69	180
1512-8MGT	1512	59.53	189
1584-8MGT	1584	62.36	198
1600-8MGT	1600	62.99	200
1760-8MGT	1760	69.29	220
1800-8MGT	1800	70.87	225
2000-8MGT	2000	78.74	250
2200-8MGT	2200	86.61	275
2400-8MGT	2400	94.49	300
2600-8MGT	2600	102.36	325
2800-8MGT	2800	110.24	350
3048-8MGT	3048	120.00	381
3280-8MGT	3280	129.13	410
3600-8MGT	3600	141.73	450
4400-8MGT	4400	173.23	550

8MGT Stock Belt Widths

Belt Width Code	Belt Width (mm)	Belt Width (in)
20	20	0.787
30	30	1.181
50	50	1.969
85	85	3.346

14mm Pitch PowerGrip GT2 Stock Belt Lengths

Designation	Pitch Length		No. of Teeth
	(mm)	(in)	
966-14MGT	966	38.03	69
1190-14MGT	1190	46.85	85
1400-14MGT	1400	55.12	100
1610-14MGT	1610	63.39	115
1778-14MGT	1778	70.00	127
1890-14MGT	1890	74.41	135
2100-14MGT	2100	82.68	150
2310-14MGT	2310	90.94	165
2450-14MGT	2450	96.46	175
2590-14MGT	2590	101.97	185
2800-14MGT	2800	110.24	200
3150-14MGT	3150	124.02	225
3360-14MGT	3360	132.28	240
3500-14MGT	3500	137.80	250
3850-14MGT	3850	151.57	275
4326-14MGT	4326	170.32	309
4578-14MGT	4578	180.24	327
4956-14MGT	4956	195.12	354
5320-14MGT	5320	209.45	380
5740-14MGT	5740	225.98	410
6160-14MGT	6160	242.52	440
6860-14MGT	6860	270.08	490

14MGT Stock Belt Widths

Belt Width Code	Belt Width (mm)	Belt Width (in)
40	40	1.575
55	55	2.165
85	85	3.346
115	115	4.528
170	170	6.693

20mm Pitch PowerGrip GT2 Stock Belt Lengths

Designation	Pitch Length		No. of Teeth
	(mm)	(in)	
2000-20M	2000	78.74	100
2500-20M	2500	98.43	125
3400-20M	3400	133.86	170
3800-20M	3800	149.61	190
4200-20M	4200	165.35	210
4600-20M	4600	181.10	230
5000-20M	5000	196.85	250
5200-20M	5200	204.72	260
5400-20M	5400	212.60	270
5600-20M	5600	220.47	280
5800-20M	5800	228.35	290
6000-20M	6000	236.22	300
6200-20M	6200	244.09	310
6400-20M	6400	251.97	320
6600-20M	6600	259.84	330

20M Stock Belt Widths

Belt Width Code	Belt Width (mm)	Belt Width (in)
115	115	4.528
170	170	6.693
230	230	9.055
290	290	11.417
340	340	13.386

Basic PowerGrip® Service Factors

DriveN Machine	DriveR					
The driveN machines listed below are representative samples only. Select a driveN machine whose load characteristics most closely approximate those of the machine being considered.	AC Motors: Normal Torque, Squirrel Cage, Synchronous, Split Phase, Inverter Controlled			AC Motors: High Torque, High Slip, Repulsion-Induction, Single Phase, Series Wound, Slip Ring		
	DC Motors: Shunt Wound Stepper Motors			DC Motors: Series Wound, Compound Wound Servo Motors		
	Engines: Multiple Cylinder Internal Combustion			Engines: Single Cylinder Internal Combustion Line Shafts Clutches		
	Intermittent Service (Up to 8 hours Daily or Seasonal)	Normal Service (8 - 16 hours Daily)	Continuous Service (16 - 24 hours Daily)	Intermittent Service (Up to 8 hours Daily or Seasonal)	Normal Service (8 - 16 hours Daily)	Continuous Service (16 - 24 hours Daily)
Display, Dispensing Equipment Instrumentation Measuring Equipment Medical Equipment Office, Projection Equipment	1.0	1.2	1.4	1.2	1.4	1.6
Appliances, Sweepers, Sewing Machines Screens, Oven Screens, Drum, Conical Woodworking Equipment (Light): Band Saws, Drills, Lathes	1.1	1.3	1.5	1.3	1.5	1.7
Agitators for Liquids Conveyors: Belt, Light Package Drill Press, Lathes, Saws Laundry Machinery Wood Working Equipment (Heavy): Circular Saws, Jointers, Planers	1.2	1.4	1.6	1.6	1.8	2.0
Agitators for Semi-Liquids Compressor: Centrifugal Conveyor Belt: Ore, Coal, Sand Dough Mixers Line Shafts Machine Tools: Grinder, Shaper, Boring Mill, Milling Machines Paper Machinery (except Pulpers): Presses, Punches, Shears Printing Machinery Pumps: Centrifugal, Gear Screens: Revolving, Vibratory	1.3	1.5	1.7	1.6	1.8	2.0
Brick Machinery (except Pug Mills) Conveyor: Apron, Pan, Bucket, Elevator Extractors, Washers Fans, Centrifugal Blowers Generators & Exciters Hoists Rubber Calender, Mills, Extruders	1.4	1.6	1.8	1.8	2.0	2.2
Centrifuges Screw Conveyors Hammer Mills Paper Pulpers Textile Machinery	1.5	1.7	1.9	1.9	2.1	2.3
Blowers: Positive Displacement, Mine Fans Pulverizers	1.6	1.8	2.0	2.0	2.2	2.4
Compressors: Reciprocating Crushers: Gyrotory, Jaw, Roll Mills: Ball, Rod, Pebble, etc. Pumps: Reciprocating Saw Mill Equipment	1.7	1.9	2.1	2.1	2.3	2.5

These service factors are adequate for most belt drive applications. Note that service factors cannot be substituted for good engineering judgment. Service factors may be adjusted based upon an understanding of the severity of actual drive operating conditions.

Additional Service Factors

Low Speed Drives

8mm / 14mm / 20mm Belts Only

Smaller Sprocket Speed	
Up to 200 rpm	Add 0.3
201 to 400 rpm	Add 0.2
401 to 600 rpm	Add 0.1

Unusual Conditions

Additional service factors are required for unusual conditions—such as load reversal, heavy shock, plugged motor stop, electric brake. These should be determined by a transmission specialist.

Speedup Drives

For speedup drives, add to the basic service factor the additional factor given below.

Speedup Ratio Range	Additional Factor	Speedup Ratio Range	Additional Factor
1 to 1.24	none	2.50 to 3.49	.30
1.25 to 1.74	.10	3.50 & over	.40
1.75 to 2.49	.20		



5mm Pitch PowerGrip® GT² Belts

Drive Selection Table

Sprocket Combinations				Speed Ratio	Center Distance, Inches											
DriveR		DriveN			5MR-300 P.L. 11.811 60 teeth	5MR-355 P.L. 13.976 71 teeth	5MR-375 P.L. 14.764 75 teeth	5MR-400 P.L. 15.748 80 teeth	5MR-405 P.L. 15.945 81 teeth	5MR-425 P.L. 16.732 85 teeth	5MR-450 P.L. 17.716 90 teeth	5MR-500 P.L. 19.685 100 teeth	5MR-535 P.L. 21.063 107 teeth	5MR-565 P.L. 22.244 113 teeth	5MR-590 P.L. 22.835 116 teeth	5MR-600 P.L. 23.622 120 teeth
No. of Grooves	Pitch Diameter (Inches)	No. of Grooves	Pitch Diameter (Inches)													
18	1.128	18	1.128	1.000	4.13	5.22	5.61	6.10	6.20	6.59	7.09	8.07	8.76	9.35	9.64	10.04
19	1.191	19	1.191	1.000	4.03	5.12	5.51	6.00	6.10	6.49	6.99	7.97	8.66	9.25	9.54	9.94
20	1.253	20	1.253	1.000	3.94	5.02	5.41	5.91	6.00	6.40	6.89	7.87	8.56	9.15	9.45	9.84
21	1.316	21	1.316	1.000	3.84	4.92	5.31	5.81	5.90	6.30	6.79	7.77	8.46	9.05	9.35	9.74
22	1.379	22	1.379	1.000	3.74	4.82	5.21	5.71	5.80	6.20	6.69	7.67	8.36	8.95	9.25	9.64
23	1.441	23	1.441	1.000	3.64	4.73	5.12	5.61	5.71	6.10	6.60	7.58	8.27	8.86	9.15	9.55
24	1.504	24	1.504	1.000	3.54	4.63	5.02	5.51	5.61	6.00	6.50	7.48	8.17	8.76	9.05	9.45
25	1.566	25	1.566	1.000	3.45	4.53	4.92	5.42	5.51	5.91	6.40	7.38	8.07	8.66	8.96	9.35
26	1.629	26	1.629	1.000	3.35	4.43	4.82	5.32	5.41	5.81	6.30	7.28	7.97	8.56	8.86	9.25
28	1.754	28	1.754	1.000	3.15	4.23	4.62	5.12	5.21	5.61	6.10	7.08	7.77	8.36	8.66	9.05
30	1.880	30	1.880	1.000	2.95	4.04	4.43	4.92	5.02	5.41	5.91	6.89	7.58	8.17	8.46	8.86
32	2.005	32	2.005	1.000	2.76	3.84	4.23	4.73	4.82	5.22	5.71	6.69	7.38	7.97	8.27	8.66
34	2.130	34	2.130	1.000	2.56	3.64	4.03	4.53	4.62	5.02	5.51	6.49	7.18	7.77	8.07	8.46
36	2.256	36	2.256	1.000		3.45	3.84	4.33	4.43	4.82	5.32	6.30	6.99	7.58	7.87	8.27
38	2.381	38	2.381	1.000		3.25	3.64	4.13	4.23	4.62	5.12	6.10	6.79	7.38	7.67	8.07
40	2.506	40	2.506	1.000		3.05	3.44	3.94	4.03	4.43	4.92	5.90	6.59	7.18	7.48	7.87
44	2.757	44	2.757	1.000				3.54	3.64	4.03	4.53	5.51	6.20	6.79	7.08	7.48
45	2.820	45	2.820	1.000				3.45	3.54	3.94	4.43	5.41	6.10	6.69	6.99	7.38
48	3.008	48	3.008	1.000						3.64	4.14	5.12	5.81	6.40	6.69	7.09
50	3.133	50	3.133	1.000							3.94	4.92	5.61	6.20	6.49	6.89
52	3.258	52	3.258	1.000							3.74	4.72	5.41	6.00	6.30	6.69
56	3.509	56	3.509	1.000								4.33	5.02	5.61	5.90	6.30
60	3.760	60	3.760	1.000									4.62	5.21	5.51	5.90
64	4.010	64	4.010	1.000										4.82	5.12	5.51
68	4.261	68	4.261	1.000											4.72	5.12
44	2.757	45	2.820	1.023				3.49	3.59	3.98	4.48	5.46	6.15	6.74	7.03	7.43
25	1.566	26	1.629	1.040	3.40	4.48	4.87	5.37	5.46	5.86	6.35	7.33	8.02	8.61	8.91	9.30
50	3.133	52	3.258	1.040							3.84	4.82	5.51	6.10	6.40	6.79
24	1.504	25	1.566	1.042	3.49	4.58	4.97	5.46	5.56	5.95	6.45	7.43	8.12	8.71	9.00	9.40
48	3.008	50	3.133	1.042						3.54	4.04	5.02	5.71	6.30	6.59	6.99
23	1.441	24	1.504	1.043	3.59	4.68	5.07	5.56	5.66	6.05	6.55	7.53	8.22	8.81	9.10	9.50
22	1.379	23	1.441	1.045	3.69	4.78	5.17	5.66	5.76	6.15	6.65	7.63	8.32	8.91	9.20	9.60
21	1.316	22	1.379	1.048	3.79	4.87	5.26	5.76	5.85	6.25	6.74	7.72	8.41	9.00	9.30	9.69
20	1.253	21	1.316	1.050	3.89	4.97	5.36	5.86	5.95	6.35	6.84	7.82	8.51	9.10	9.40	9.79
19	1.191	20	1.253	1.053	3.99	5.07	5.46	5.96	6.05	6.45	6.94	7.92	8.61	9.20	9.50	9.89
38	2.381	40	2.506	1.053		3.15	3.54	4.04	4.13	4.53	5.02	6.00	6.69	7.28	7.58	7.97
18	1.128	19	1.191	1.056	4.08	5.17	5.56	6.05	6.15	6.54	7.04	8.02	8.71	9.30	9.59	9.99
36	2.256	38	2.381	1.056		3.35	3.74	4.23	4.33	4.72	5.22	6.20	6.89	7.48	7.77	8.17
34	2.130	36	2.256	1.059		3.54	3.93	4.43	4.52	4.92	5.41	6.39	7.08	7.67	7.97	8.37
68	4.261	72	4.511	1.059												4.92
32	2.005	34	2.130	1.063	2.66	3.74	4.13	4.63	4.72	5.12	5.61	6.59	7.28	7.87	8.17	8.56
64	4.010	68	4.261	1.063										4.62	4.92	5.31
30	1.880	32	2.005	1.067	2.85	3.94	4.33	4.82	4.92	5.31	5.81	6.79	7.48	8.07	8.36	8.76
45	2.820	48	3.008	1.067				3.30	3.39	3.79	4.28	5.26	5.95	6.54	6.84	7.23
60	3.760	64	4.010	1.067									4.43	5.02	5.31	5.71
28	1.754	30	1.880	1.071	3.05	4.14	4.53	5.02	5.12	5.51	6.01	6.99	7.68	8.27	8.56	8.96
56	3.509	60	3.760	1.071								4.13	4.82	5.41	5.70	6.10
26	1.629	28	1.754	1.077	3.25	4.33	4.72	5.22	5.31	5.71	6.20	7.18	7.87	8.46	8.76	9.15
52	3.258	56	3.509	1.077								4.52	5.21	5.80	6.10	6.49
24	1.504	26	1.629	1.083	3.44	4.53	4.92	5.41	5.51	5.90	6.40	7.38	8.07	8.66	8.95	9.35
48	3.008	52	3.258	1.083							3.94	4.92	5.61	6.20	6.49	6.89
23	1.441	25	1.566	1.087	3.54	4.63	5.02	5.51	5.61	6.00	6.50	7.48	8.17	8.76	9.05	9.45
22	1.379	24	1.504	1.091	3.64	4.73	5.12	5.61	5.71	6.10	6.60	7.58	8.27	8.86	9.15	9.55
44	2.757	48	3.008	1.091				3.34	3.44	3.84	4.33	5.31	6.00	6.59	6.89	7.28
21	1.316	23	1.441	1.095	3.74	4.82	5.21	5.71	5.80	6.20	6.69	7.67	8.36	8.95	9.25	9.64
20	1.253	22	1.379	1.100	3.84	4.92	5.31	5.81	5.90	6.30	6.79	7.77	8.46	9.05	9.35	9.74
40	2.506	44	2.757	1.100			3.24	3.74	3.83	4.23	4.72	5.71	6.40	6.99	7.28	7.68
19	1.191	21	1.316	1.105	3.94	5.02	5.41	5.91	6.00	6.40	6.89	7.87	8.56	9.15	9.45	9.84
18	1.128	20	1.253	1.111	4.03	5.12	5.51	6.00	6.10	6.49	6.99	7.97	8.66	9.25	9.54	9.94
36	2.256	40	2.506	1.111		3.25	3.64	4.13	4.23	4.62	5.12	6.10	6.79	7.38	7.67	8.07
45	2.820	50	3.133	1.111					3.29	3.69	4.18	5.16	5.85	6.44	6.74	7.13
34	2.130	38	2.381	1.118		3.44	3.84	4.33	4.43	4.82	5.32	6.30	6.99	7.58	7.87	8.27
25	1.566	28	1.754	1.120	3.30	4.38	4.77	5.27	5.36	5.76	6.25	7.23	7.92	8.51	8.81	9.20
50	3.133	56	3.509	1.120							3.64	4.62	5.31	5.90	6.20	6.59
Length Factor*					0.77	0.81	0.83	0.84	0.85	0.86	0.88	0.90	0.92	0.94	0.95	0.95

*This length factor must be used to determine the proper belt width.

 Center Distance is greater than eight times the small diameter and the large sprocket is not flanged. See Engineering Section I-10, Use of Flanged Sprockets, on page 134.



Table with columns for Center Distance (Inches), Speed Ratio, No. of grooves (DriveR, DriveN), and Sprocket Combinations. Rows list belt types and their respective dimensions.

*This length correction factor must be used to determine the proper belt width.

Center Distance is greater than eight times the small diameter and the large sprocket is not flanged. See Engineering Section I-10, Use of Flanged Sprockets, on page 134.



5mm Pitch PowerGrip® GT² Belts

Drive Selection Table

Sprocket Combinations				Speed Ratio	Center Distance, Inches											
DriveR		DriveN			5MR-300 P.L. 11.811 60 teeth	5MR-355 P.L. 13.976 71 teeth	5MR-375 P.L. 14.764 75 teeth	5MR-400 P.L. 15.748 80 teeth	5MR-405 P.L. 15.945 81 teeth	5MR-425 P.L. 16.732 85 teeth	5MR-450 P.L. 17.716 90 teeth	5MR-500 P.L. 19.685 100 teeth	5MR-535 P.L. 21.063 107 teeth	5MR-565 P.L. 22.244 113 teeth	5MR-590 P.L. 22.835 116 teeth	5MR-600 P.L. 23.622 120 teeth
No. of Grooves	Pitch Diameter (Inches)	No. of Grooves	Pitch Diameter (Inches)													
32	2.005	36	2.256	1.125	2.56	3.64	4.03	4.53	4.62	5.02	5.51	6.49	7.18	7.77	8.07	8.46
40	2.506	45	2.820	1.125			3.19	3.69	3.78	4.18	4.67	5.65	6.35	6.94	7.23	7.63
64	4.010	72	4.511	1.125										4.42	4.72	5.11
23	1.441	26	1.629	1.130	3.49	4.58	4.97	5.46	5.56	5.95	6.45	7.43	8.12	8.71	9.00	9.40
30	1.880	34	2.130	1.133	2.75	3.84	4.23	4.72	4.82	5.21	5.71	6.69	7.38	7.97	8.26	8.66
60	3.760	68	4.261	1.133										4.81	5.11	5.50
22	1.379	25	1.566	1.136	3.59	4.68	5.07	5.56	5.66	6.05	6.55	7.53	8.22	8.81	9.10	9.50
44	2.757	50	3.133	1.136					3.34	3.73	4.23	5.21	5.90	6.49	6.79	7.18
21	1.316	24	1.504	1.143	3.69	4.77	5.16	5.66	5.75	6.15	6.64	7.62	8.31	8.90	9.20	9.59
28	1.754	32	2.005	1.143	2.95	4.04	4.43	4.92	5.02	5.41	5.91	6.89	7.58	8.17	8.46	8.86
56	3.509	64	4.010	1.143										4.62	5.21	5.50
20	1.253	23	1.441	1.150	3.79	4.87	5.26	5.76	5.85	6.25	6.74	7.72	8.41	9.00	9.30	9.69
26	1.629	30	1.880	1.154	3.15	4.23	4.62	5.12	5.21	5.61	6.10	7.08	7.77	8.36	8.66	9.05
52	3.258	60	3.760	1.154								4.32	5.01	5.60	5.90	6.29
45	2.820	52	3.258	1.156						3.58	4.08	5.06	5.75	6.34	6.64	7.03
19	1.191	22	1.379	1.158	3.89	4.97	5.36	5.86	5.95	6.35	6.84	7.82	8.51	9.10	9.40	9.79
38	2.381	44	2.757	1.158		2.95	3.34	3.84	3.93	4.33	4.82	5.80	6.49	7.08	7.38	7.77
18	1.128	21	1.316	1.167	3.98	5.07	5.46	5.95	6.05	6.44	6.94	7.92	8.61	9.20	9.50	9.89
24	1.504	28	1.754	1.167	3.34	4.43	4.82	5.31	5.41	5.80	6.30	7.28	7.97	8.56	8.86	9.25
48	3.008	56	3.509	1.167								3.73	4.71	5.41	6.00	6.29
34	2.130	40	2.506	1.176		3.34	3.73	4.23	4.32	4.72	5.22	6.20	6.89	7.48	7.77	8.17
68	4.261	80	5.013	1.176												
22	1.379	26	1.629	1.182	3.54	4.63	5.02	5.51	5.61	6.00	6.50	7.48	8.17	8.76	9.05	9.45
44	2.757	52	3.258	1.182						3.63	4.13	5.11	5.80	6.39	6.69	7.08
38	2.381	45	2.820	1.184			3.29	3.78	3.88	4.27	4.77	5.75	6.44	7.03	7.33	7.72
32	2.005	38	2.381	1.188		3.54	3.93	4.43	4.52	4.92	5.41	6.39	7.08	7.67	7.97	8.36
21	1.316	25	1.566	1.190	3.64	4.72	5.11	5.61	5.71	6.10	6.60	7.58	8.27	8.86	9.15	9.55
20	1.253	24	1.504	1.200	3.74	4.82	5.21	5.71	5.80	6.20	6.69	7.67	8.36	8.95	9.25	9.64
25	1.566	30	1.880	1.200	3.19	4.28	4.67	5.17	5.26	5.66	6.15	7.13	7.82	8.41	8.71	9.10
30	1.880	36	2.256	1.200	2.65	3.74	4.13	4.62	4.72	5.11	5.61	6.59	7.28	7.87	8.16	8.56
40	2.506	48	3.008	1.200				3.54	3.63	4.03	4.52	5.50	6.19	6.78	7.08	7.48
50	3.133	60	3.760	1.200							4.42	5.11	5.70	5.99	6.29	6.69
60	3.760	72	4.511	1.200										4.61	4.90	5.30
19	1.191	23	1.441	1.211	3.84	4.92	5.31	5.81	5.90	6.30	6.79	7.77	8.46	9.05	9.35	9.74
28	1.754	34	2.130	1.214	2.85	3.94	4.33	4.82	4.92	5.31	5.81	6.79	7.48	8.07	8.36	8.76
56	3.509	68	4.261	1.214								4.41	5.00	5.30	5.70	6.10
23	1.441	28	1.754	1.217	3.39	4.48	4.87	5.36	5.46	5.85	6.35	7.33	8.02	8.61	8.90	9.30
18	1.128	22	1.379	1.222	3.93	5.02	5.41	5.90	6.00	6.39	6.89	7.87	8.56	9.15	9.45	9.84
36	2.256	44	2.757	1.222		3.04	3.43	3.93	4.03	4.42	4.92	5.90	6.59	7.18	7.47	7.87
26	1.629	32	2.005	1.231	3.05	4.13	4.52	5.02	5.11	5.51	6.00	6.98	7.67	8.26	8.56	8.95
52	3.258	64	4.010	1.231								4.11	4.81	5.40	5.69	6.09
21	1.316	26	1.629	1.238	3.59	4.67	5.06	5.56	5.65	6.05	6.55	7.53	8.22	8.81	9.10	9.50
45	2.820	56	3.509	1.244							3.87	4.86	5.55	6.14	6.43	6.83
20	1.253	25	1.566	1.250	3.69	4.77	5.16	5.66	5.75	6.15	6.64	7.62	8.31	8.90	9.20	9.59
24	1.504	30	1.880	1.250	3.24	4.33	4.72	5.21	5.31	5.70	6.20	7.18	7.87	8.46	8.76	9.15
32	2.005	40	2.506	1.250		3.44	3.83	4.32	4.42	4.82	5.31	6.29	6.98	7.57	7.87	8.26
36	2.256	45	2.820	1.250		2.99	3.38	3.88	3.97	4.37	4.87	5.85	6.54	7.13	7.42	7.82
40	2.506	50	3.133	1.250				3.43	3.53	3.92	4.42	5.40	6.09	6.68	6.98	7.37
48	3.008	60	3.760	1.250								4.51	5.20	5.79	6.09	6.48
64	4.010	80	5.013	1.250												4.70
19	1.191	24	1.504	1.263	3.79	4.87	5.26	5.76	5.85	6.25	6.74	7.72	8.41	9.00	9.30	9.69
38	2.381	48	3.008	1.263			3.13	3.63	3.72	4.12	4.62	5.60	6.29	6.88	7.18	7.57
30	1.880	38	2.381	1.267	2.55	3.63	4.03	4.52	4.62	5.01	5.51	6.49	7.18	7.77	8.06	8.46
22	1.379	28	1.754	1.273	3.44	4.53	4.92	5.41	5.51	5.90	6.40	7.38	8.07	8.66	8.95	9.35
44	2.757	56	3.509	1.273							3.92	4.90	5.60	6.19	6.48	6.88
18	1.128	23	1.441	1.278	3.88	4.97	5.36	5.86	5.95	6.35	6.84	7.82	8.51	9.10	9.40	9.79
25	1.566	32	2.005	1.280	3.09	4.18	4.57	5.07	5.16	5.56	6.05	7.03	7.72	8.31	8.61	9.00
50	3.133	64	4.010	1.280							4.21	4.90	5.49	5.79	6.18	6.58
28	1.754	36	2.256	1.286	2.74	3.83	4.22	4.72	4.81	5.21	5.71	6.69	7.38	7.97	8.26	8.66
56	3.509	72	4.511	1.286								4.20	4.79	5.09	5.49	5.89
34	2.130	44	2.757	1.294		3.14	3.53	4.02	4.12	4.52	5.01	5.99	6.68	7.28	7.57	7.97
20	1.253	26	1.629	1.300	3.64	4.72	5.11	5.61	5.70	6.10	6.59	7.57	8.26	8.85	9.15	9.54
40	2.506	52	3.258	1.300				3.33	3.42	3.82	4.32	5.30	5.99	6.58	6.88	7.27
23	1.441	30	1.880	1.304	3.29	4.38	4.77	5.26	5.36	5.75	6.25	7.23	7.92	8.51	8.80	9.20
Length Factor*					0.77	0.81	0.83	0.84	0.85	0.86	0.88	0.90	0.92	0.94	0.95	0.95

*This length factor must be used to determine the proper belt width.

Center Distance is greater than eight times the small diameter and the large sprocket is not flanged. See Engineering Section I-10, Use of Flanged Sprockets, on page 134.



Center Distance, Inches															Sprocket Combinations	
5MR-625 P.L. 24.606 125 teeth	5MR-650 P.L. 25.580 130 teeth	5MR-700 P.L. 27.559 140 teeth	5MR-750 P.L. 29.528 150 teeth	5MR-800 P.L. 31.496 160 teeth	5MR-850 P.L. 33.465 170 teeth	5MR-900 P.L. 35.433 180 teeth	5MR-1000 P.L. 39.370 200 teeth	5MR-1150 P.L. 45.276 230 teeth	5MR-1300 P.L. 51.181 260 teeth	5MR-1450 P.L. 57.087 290 teeth	5MR-1600 P.L. 62.992 320 teeth	5MR-1750 P.L. 67.716 344 teeth	5MR-2100 P.L. 82.677 420 teeth	Speed Ratio	Drive	
															DriveR	DriveN
															No. of grooves	No. of grooves
8.96	9.45	10.43	11.42	12.40	13.38	14.37	16.34	19.29	22.24	25.20	28.15	30.51	37.99	1.125	32	36
8.12	8.61	9.60	10.58	11.57	12.55	13.53	15.50	18.46	21.41	24.36	27.31	29.68	37.16	1.125	40	45
5.61	6.10	7.08	8.07	9.05	10.03	11.02	12.99	15.95	18.90	21.85	24.80	27.17	34.65	1.125	64	72
9.89	10.38	11.37	12.35	13.34	14.32	15.30	17.27	20.23	23.18	26.13	29.08	31.45	38.93	1.130	23	26
9.15	9.64	10.63	11.61	12.60	13.58	14.57	16.54	19.49	22.44	25.40	28.35	30.71	38.19	1.133	30	34
6.00	6.49	7.48	8.46	9.45	10.43	11.41	13.38	16.34	19.29	22.24	25.19	27.56	35.04	1.133	60	68
9.99	10.48	11.47	12.45	13.44	14.42	15.40	17.37	20.33	23.28	26.23	29.18	31.55	39.03	1.136	22	25
7.68	8.17	9.15	10.14	11.12	12.10	13.09	15.06	18.01	20.96	23.92	26.87	29.23	36.71	1.136	44	50
10.09	10.58	11.56	12.55	13.53	14.51	15.50	17.47	20.42	23.37	26.33	29.28	31.65	39.13	1.143	21	24
9.35	9.84	10.83	11.81	12.80	13.78	14.76	16.73	19.69	22.64	25.59	28.54	30.91	38.39	1.143	28	32
6.39	6.89	7.87	8.86	9.84	10.82	11.81	13.78	16.73	19.68	22.64	25.59	27.95	35.43	1.143	56	64
10.19	10.68	11.66	12.65	13.63	14.61	15.60	17.57	20.52	23.47	26.43	29.38	31.74	39.22	1.150	20	23
9.55	10.04	11.02	12.01	12.99	13.97	14.96	16.93	19.88	22.83	25.79	28.74	31.10	38.58	1.154	26	30
6.79	7.28	8.26	9.25	10.23	11.22	12.20	14.17	17.13	20.08	23.03	25.98	28.35	35.83	1.154	52	60
7.53	8.02	9.00	9.99	10.97	11.95	12.94	14.91	17.87	20.82	23.77	26.72	29.09	36.57	1.156	45	52
10.29	10.78	11.76	12.75	13.73	14.71	15.70	17.67	20.62	23.57	26.53	29.48	31.84	39.32	1.158	19	22
8.27	8.76	9.74	10.73	11.71	12.69	13.68	15.65	18.60	21.55	24.51	27.46	29.82	37.30	1.158	38	44
10.39	10.88	11.86	12.85	13.83	14.81	15.80	17.77	20.72	23.67	26.63	29.58	31.94	39.42	1.167	18	21
9.75	10.24	11.22	12.21	13.19	14.17	15.16	17.13	20.08	23.03	25.99	28.94	31.30	38.78	1.167	24	28
7.18	7.67	8.66	9.64	10.63	11.61	12.59	14.56	17.52	20.47	23.43	26.38	28.74	36.22	1.167	48	56
8.66	9.15	10.14	11.12	12.11	13.09	14.07	16.04	19.00	21.95	24.90	27.85	30.22	37.70	1.176	34	40
5.01	5.50	6.49	7.47	8.46	9.44	10.42	12.40	15.35	18.30	21.26	24.21	26.57	34.05	1.176	68	80
9.94	10.43	11.42	12.40	13.39	14.37	15.35	17.32	20.28	23.23	26.18	29.13	31.50	38.98	1.182	22	26
7.58	8.07	9.05	10.04	11.02	12.00	12.99	14.96	17.91	20.86	23.82	26.77	29.13	36.61	1.182	44	52
8.22	8.71	9.69	10.68	11.66	12.64	13.63	15.60	18.55	21.50	24.46	27.41	29.77	37.25	1.184	38	45
8.86	9.35	10.33	11.32	12.30	13.28	14.27	16.24	19.19	22.14	25.10	28.05	30.41	37.89	1.188	32	38
10.04	10.53	11.52	12.50	13.49	14.47	15.45	17.42	20.38	23.33	26.28	29.23	31.60	39.08	1.190	21	25
10.14	10.63	11.61	12.60	13.58	14.56	15.55	17.52	20.47	23.42	26.38	29.33	31.69	39.17	1.200	20	24
9.60	10.09	11.07	12.06	13.04	14.02	15.01	16.98	19.93	22.88	25.84	28.79	31.15	38.63	1.200	25	30
9.05	9.54	10.53	11.52	12.50	13.48	14.47	16.44	19.39	22.34	25.30	28.25	30.61	38.09	1.200	30	36
7.97	8.46	9.45	10.43	11.42	12.40	13.38	15.35	18.31	21.26	24.21	27.16	29.53	37.01	1.200	40	48
6.88	7.37	8.36	9.35	10.33	11.31	12.30	14.27	17.22	20.17	23.13	26.08	28.44	35.92	1.200	50	60
5.80	6.29	7.27	8.26	9.25	10.23	11.21	13.18	16.14	19.09	22.05	25.00	27.36	34.84	1.200	60	72
10.24	10.73	11.71	12.70	13.68	14.66	15.65	17.62	20.57	23.52	26.48	29.43	31.79	39.27	1.211	19	23
9.25	9.74	10.73	11.71	12.70	13.68	14.66	16.63	19.59	22.54	25.49	28.44	30.81	38.29	1.214	28	34
6.19	6.68	7.67	8.65	9.64	10.62	11.61	13.58	16.53	19.48	22.44	25.39	27.75	35.24	1.214	56	68
9.79	10.28	11.27	12.25	13.24	14.22	15.20	17.17	20.13	23.08	26.04	28.99	31.35	38.83	1.217	23	28
10.34	10.83	11.81	12.80	13.78	14.76	15.75	17.72	20.67	23.62	26.58	29.53	31.89	39.37	1.222	18	22
8.36	8.85	9.84	10.82	11.81	12.79	13.78	15.75	18.70	21.65	24.61	27.56	29.92	37.40	1.222	36	44
9.45	9.94	10.92	11.91	12.89	13.87	14.86	16.83	19.78	22.74	25.69	28.64	31.01	38.49	1.231	26	32
6.59	7.08	8.06	9.05	10.03	11.02	12.00	13.97	16.93	19.88	22.83	25.78	28.15	35.63	1.231	52	64
9.99	10.48	11.47	12.45	13.44	14.42	15.40	17.37	20.33	23.28	26.23	29.18	31.55	39.03	1.238	21	26
7.33	7.82	8.80	9.79	10.77	11.75	12.74	14.71	17.67	20.62	23.57	26.52	28.89	36.37	1.244	45	56
10.09	10.58	11.56	12.55	13.54	14.52	15.50	17.47	20.43	23.38	26.33	29.28	31.65	39.13	1.250	20	25
9.65	10.14	11.12	12.11	13.09	14.07	15.06	17.03	19.98	22.93	25.89	28.84	31.20	38.68	1.250	24	30
8.76	9.25	10.23	11.22	12.20	13.18	14.17	16.14	19.10	22.05	25.00	27.95	30.32	37.80	1.250	32	40
8.31	8.80	9.79	10.77	11.76	12.74	13.73	15.70	18.65	21.60	24.56	27.51	29.87	37.35	1.250	36	45
7.87	8.36	9.35	10.33	11.32	12.30	13.28	15.25	18.21	21.16	24.11	27.06	29.43	36.91	1.250	40	50
6.98	7.47	8.46	9.44	10.43	11.41	12.39	14.36	17.32	20.27	23.23	26.18	28.54	36.02	1.250	48	60
5.19	5.69	6.67	7.66	8.65	9.63	10.62	12.59	15.55	18.50	21.45	24.40	26.77	34.25	1.250	64	80
10.19	10.68	11.66	12.65	13.63	14.61	15.60	17.57	20.52	23.47	26.43	29.38	31.74	39.22	1.263	19	24
8.07	8.56	9.54	10.53	11.51	12.49	13.48	15.45	18.40	21.36	24.31	27.26	29.63	37.11	1.263	38	48
8.95	9.45	10.43	11.42	12.40	13.38	14.37	16.34	19.29	22.24	25.20	28.15	30.51	37.99	1.267	30	38
9.84	10.33	11.32	12.30	13.29	14.27	15.25	17.22	20.18	23.13	26.08	29.03	31.40	38.88	1.273	22	28
7.37	7.86	8.85	9.84	10.82	11.80	12.79	14.76	17.71	20.67	23.62	26.57	28.94	36.42	1.273	44	56
10.29	10.78	11.76	12.75	13.73	14.71	15.70	17.67	20.62	23.57	26.53	29.48	31.84	39.32	1.278	18	23
9.50	9.99	10.97	11.96	12.94	13.92	14.91	16.88	19.83	22.78	25.74	28.69	31.05	38.53	1.280	25	32
6.68	7.17	8.16	9.14	10.13	11.11	12.10	14.07	17.02	19.98	22.93	25.88	28.25	35.73	1.280	50	64
9.15	9.64	10.63	11.61	12.60	13.58	14.56	16.53	19.49	22.44	25.39	28.34	30.71	38.19	1.286	28	36
5.99	6.48	7.46	8.45	9.44	10.42	11.41	13.38	16.33	19.28	22.24	25.19	27.56	35.04	1.286	56	72
8.46	8.95	9.94	10.92	11.91	12.89	13.87	15.84	18.80	21.75	24.70	27.65	30.02	37.50	1.294	34	44
10.04	10.53	11.51	12.50	13.49	14.47	15.45	17.42	20.38	23.33	26.28	29.23	31.60	39.08	1.300	20	26
7.77	8.26	9.25	10.23	11.22	12.20	13.18	15.15	18.11	21.06	24.02	26.97	29.33	36.81	1.300	40	52
9.69	10.18	11.17	12.15	13.14	14.12	15.11	17.08	20.03	22.98	25.94	28.89	31.25	38.73	1.304	23	30
0.97	0.98	1.00	1.01	1.03	1.05	1.06	1.09	1.13	1.16	1.19	1.22	1.24	1.29			

*This length correction factor must be used to determine the proper belt width.

Center Distance is greater than eight times the small diameter and the large sprocket is not flanged. See Engineering Section I-10, Use of Flanged Sprockets, on page 134.



5mm Pitch PowerGrip® GT² Belts

Drive Selection Table

Sprocket Combinations				Speed Ratio	Center Distance, Inches												
DriveR		DriveN			5MR-300 P.L. 11.811 60 teeth	5MR-355 P.L. 13.976 71 teeth	5MR-375 P.L. 14.764 75 teeth	5MR-400 P.L. 15.748 80 teeth	5MR-405 P.L. 15.945 81 teeth	5MR-425 P.L. 16.732 85 teeth	5MR-450 P.L. 17.716 90 teeth	5MR-500 P.L. 19.685 100 teeth	5MR-535 P.L. 21.063 107 teeth	5MR-565 P.L. 22.244 113 teeth	5MR-590 P.L. 22.835 116 teeth	5MR-600 P.L. 23.622 120 teeth	
No. of Grooves	Pitch Diameter (Inches)	No. of Grooves	Pitch Diameter (Inches)														
26	1.629	34	2.130	1.308	2.94	4.03	4.42	4.92	5.01	5.41	5.90	6.88	7.57	8.16	8.46	8.85	
52	3.258	68	4.261	1.308									4.60	5.19	5.49	5.88	
19	1.191	25	1.566	1.316	3.73	4.82	5.21	5.71	5.80	6.20	6.69	7.67	8.36	8.95	9.25	9.64	
38	2.381	50	3.133	1.316				3.52	3.62	4.02	4.51	5.50	6.19	6.78	7.07	7.47	
34	2.130	45	2.820	1.324		3.08	3.48	3.97	4.07	4.46	4.96	5.94	6.63	7.22	7.52	7.91	
68	4.261	90	5.639	1.324													
18	1.128	24	1.504	1.333	3.83	4.92	5.31	5.80	5.90	6.30	6.79	7.77	8.46	9.05	9.35	9.74	
21	1.316	28	1.754	1.333	3.49	4.57	4.96	5.46	5.55	5.95	6.45	7.43	8.12	8.71	9.00	9.40	
24	1.504	32	2.005	1.333	3.14	4.23	4.62	5.11	5.21	5.60	6.10	7.08	7.77	8.36	8.66	9.05	
30	1.880	40	2.506	1.333		3.53	3.92	4.42	4.51	4.91	5.41	6.39	7.08	7.67	7.96	8.36	
36	2.256	48	3.008	1.333			3.22	3.72	3.82	4.21	4.71	5.69	6.38	6.98	7.27	7.67	
45	2.820	60	3.760	1.333							3.66	4.65	5.34	5.93	6.23	6.63	
48	3.008	64	4.010	1.333								4.30	4.99	5.59	5.88	6.28	
60	3.760	80	5.013	1.333												4.88	
28	1.754	38	2.381	1.357	2.64	3.73	4.12	4.62	4.71	5.11	5.60	6.58	7.28	7.87	8.16	8.56	
25	1.566	34	2.130	1.360	2.99	4.08	4.47	4.96	5.06	5.45	5.95	6.93	7.62	8.21	8.51	8.90	
50	3.133	68	4.261	1.360									4.69	5.28	5.58	5.98	
22	1.379	30	1.880	1.364	3.34	4.42	4.81	5.31	5.40	5.80	6.30	7.28	7.97	8.56	8.85	9.25	
44	2.757	60	3.760	1.364							3.71	4.69	5.39	5.98	6.28	6.67	
19	1.191	26	1.629	1.368	3.68	4.77	5.16	5.66	5.75	6.15	6.64	7.62	8.31	8.90	9.20	9.59	
38	2.381	52	3.258	1.368				3.42	3.51	3.91	4.41	5.39	6.09	6.68	6.97	7.37	
32	2.005	44	2.757	1.375		3.23	3.62	4.12	4.21	4.61	5.11	6.09	6.78	7.37	7.67	8.06	
26	1.629	36	2.256	1.385	2.84	3.93	4.32	4.81	4.91	5.30	5.80	6.78	7.47	8.06	8.36	8.75	
52	3.258	72	4.511	1.385									4.38	4.98	5.28	5.67	
18	1.128	25	1.566	1.389	3.78	4.87	5.26	5.75	5.85	6.25	6.74	7.72	8.41	9.00	9.30	9.69	
36	2.256	50	3.133	1.389			3.12	3.62	3.71	4.11	4.61	5.59	6.28	6.87	7.17	7.56	
23	1.441	32	2.005	1.391	3.19	4.27	4.66	5.16	5.26	5.65	6.15	7.13	7.82	8.41	8.70	9.10	
20	1.253	28	1.754	1.400	3.53	4.62	5.01	5.51	5.60	6.00	6.49	7.47	8.16	8.75	9.05	9.44	
40	2.506	56	3.509	1.400						3.61	4.11	5.09	5.78	6.38	6.67	7.07	
32	2.005	45	2.820	1.406		3.17	3.57	4.07	4.16	4.56	5.05	6.04	6.73	7.32	7.61	8.01	
64	4.010	90	5.639	1.406													
34	2.130	48	3.008	1.412		2.92	3.32	3.81	3.91	4.31	4.80	5.79	6.48	7.07	7.37	7.76	
24	1.504	34	2.130	1.417	3.03	4.12	4.52	5.01	5.11	5.50	6.00	6.98	7.67	8.26	8.56	8.95	
48	3.008	68	4.261	1.417								4.08	4.78	5.37	5.67	6.07	
45	2.820	64	4.010	1.422								4.44	5.13	5.72	6.02	6.42	
21	1.316	30	1.880	1.429	3.38	4.47	4.86	5.36	5.45	5.85	6.34	7.32	8.01	8.61	8.90	9.30	
28	1.754	40	2.506	1.429	2.53	3.62	4.02	4.51	4.61	5.01	5.50	6.48	7.17	7.77	8.06	8.46	
56	3.509	80	5.013	1.429										4.66	5.06		
25	1.566	36	2.256	1.440	2.88	3.97	4.36	4.86	4.96	5.35	5.85	6.83	7.52	8.11	8.41	8.80	
50	3.133	72	4.511	1.440									4.47	5.07	5.37	5.77	
18	1.128	26	1.629	1.444	3.73	4.82	5.21	5.70	5.80	6.19	6.69	7.67	8.36	8.95	9.25	9.64	
36	2.256	52	3.258	1.444				3.51	3.60	4.00	4.50	5.49	6.18	6.77	7.07	7.46	
22	1.379	32	2.005	1.455	3.23	4.32	4.71	5.21	5.30	5.70	6.19	7.18	7.87	8.46	8.75	9.15	
44	2.757	64	4.010	1.455								4.48	5.18	5.77	6.07	6.46	
26	1.629	38	2.381	1.462	2.73	3.82	4.21	4.71	4.81	5.20	5.70	6.68	7.37	7.96	8.26	8.65	
30	1.880	44	2.757	1.467		3.32	3.71	4.21	4.31	4.70	5.20	6.18	6.87	7.47	7.76	8.16	
34	2.130	50	3.133	1.471			3.21	3.71	3.80	4.20	4.70	5.68	6.38	6.97	7.26	7.66	
19	1.191	28	1.754	1.474	3.58	4.67	5.06	5.55	5.65	6.05	6.54	7.52	8.21	8.80	9.10	9.49	
38	2.381	56	3.509	1.474					3.30	3.70	4.20	5.18	5.88	6.47	6.77	7.16	
23	1.441	34	2.130	1.478	3.08	4.17	4.56	5.06	5.15	5.55	6.05	7.03	7.72	8.31	8.60	9.00	
20	1.253	30	1.880	1.500	3.43	4.52	4.91	5.41	5.50	5.90	6.39	7.37	8.06	8.65	8.95	9.34	
24	1.504	36	2.256	1.500	2.93	4.02	4.41	4.91	5.00	5.40	5.89	6.88	7.57	8.16	8.45	8.85	
30	1.880	45	2.820	1.500		3.26	3.66	4.16	4.25	4.65	5.15	6.13	6.82	7.41	7.71	8.11	
32	2.005	48	3.008	1.500		3.01	3.41	3.91	4.00	4.40	4.90	5.88	6.57	7.17	7.46	7.86	
40	2.506	60	3.760	1.500							3.89	4.88	5.57	6.17	6.46	6.86	
48	3.008	72	4.511	1.500									4.56	5.16	5.46	5.86	
60	3.760	90	5.639	1.500													
45	2.820	68	4.261	1.511								4.22	4.92	5.51	5.81	6.21	
25	1.566	38	2.381	1.520	2.78	3.87	4.26	4.76	4.85	5.25	5.75	6.73	7.42	8.01	8.31	8.70	
21	1.316	32	2.005	1.524	3.28	4.37	4.76	5.26	5.35	5.75	6.24	7.22	7.91	8.50	8.80	9.20	
34	2.130	52	3.258	1.529			3.10	3.60	3.70	4.09	4.59	5.58	6.27	6.87	7.16	7.56	
26	1.629	40	2.506	1.538	2.62	3.72	4.11	4.61	4.70	5.10	5.60	6.58	7.27	7.86	8.16	8.55	
52	3.258	80	5.013	1.538										4.54	4.84	5.24	
22	1.379	34	2.130	1.545	3.13	4.22	4.61	5.11	5.20	5.60	6.09	7.07	7.76	8.36	8.65	9.05	
Length Factor*					0.77	0.81	0.83	0.84	0.85	0.86	0.88	0.90	0.92	0.94	0.95	0.95	

*This length factor must be used to determine the proper belt width.

 Center Distance is greater than eight times the small diameter and the large sprocket is not flanged. See Engineering Section I-10, Use of Flanged Sprockets, on page 134.



Center Distance, Inches														Sprocket Combinations		
5MR-625 P.L. 24.606 125 teeth	5MR-650 P.L. 25.580 130 teeth	5MR-700 P.L. 27.559 140 teeth	5MR-750 P.L. 29.528 150 teeth	5MR-800 P.L. 31.496 160 teeth	5MR-850 P.L. 33.465 170 teeth	5MR-900 P.L. 35.433 180 teeth	5MR-1000 P.L. 39.370 200 teeth	5MR-1150 P.L. 45.276 230 teeth	5MR-1300 P.L. 51.181 260 teeth	5MR-1450 P.L. 57.087 290 teeth	5MR-1600 P.L. 62.992 320 teeth	5MR-1750 P.L. 67.716 344 teeth	5MR-2100 P.L. 82.677 420 teeth	Speed Ratio	Sprocket Combinations	
															DriveR	DriveN
															No. of grooves	No. of grooves
9.35	9.84	10.82	11.81	12.80	13.78	14.76	16.73	19.69	22.64	25.59	28.54	30.91	38.39	1.308	26	34
6.38	6.87	7.86	8.85	9.83	10.81	11.80	13.77	16.73	19.68	22.63	25.58	27.95	35.43	1.308	52	68
10.14	10.63	11.61	12.60	13.58	14.56	15.55	17.52	20.47	23.42	26.38	29.33	31.69	39.17	1.316	19	25
7.97	8.46	9.44	10.43	11.41	12.39	13.38	15.35	18.31	21.26	24.21	27.16	29.53	37.01	1.316	38	50
8.41	8.90	9.89	10.87	11.86	12.84	13.82	15.79	18.75	21.70	24.65	27.61	29.97	37.45	1.324	34	45
		5.96	6.96	7.94	8.93	9.92	11.89	14.85	17.80	20.76	23.71	26.08	33.56	1.324	68	90
10.24	10.73	11.71	12.70	13.68	14.66	15.65	17.62	20.57	23.52	26.48	29.43	31.79	39.27	1.333	18	24
9.89	10.38	11.37	12.35	13.34	14.32	15.30	17.27	20.23	23.18	26.13	29.08	31.45	38.93	1.333	21	28
9.55	10.04	11.02	12.01	12.99	13.97	14.96	16.93	19.88	22.83	25.79	28.74	31.10	38.58	1.333	24	32
8.85	9.35	10.33	11.32	12.30	13.28	14.27	16.24	19.19	22.14	25.10	28.05	30.41	37.89	1.333	30	40
8.16	8.65	9.64	10.62	11.61	12.59	13.58	15.55	18.50	21.45	24.41	27.36	29.72	37.20	1.333	36	48
7.12	7.61	8.60	9.59	10.57	11.55	12.54	14.51	17.47	20.42	23.37	26.32	28.69	36.17	1.333	45	60
6.77	7.27	8.25	9.24	10.23	11.21	12.19	14.16	17.12	20.07	23.03	25.98	28.34	35.82	1.333	48	64
5.38	5.87	6.86	7.85	8.84	9.82	10.81	12.78	15.74	18.69	21.65	24.60	26.96	34.44	1.333	60	80
9.05	9.54	10.53	11.51	12.50	13.48	14.46	16.43	19.39	22.34	25.30	28.25	30.61	38.09	1.357	28	38
9.40	9.89	10.87	11.86	12.84	13.82	14.81	16.78	19.74	22.69	25.64	28.59	30.96	38.44	1.360	25	34
6.47	6.96	7.95	8.94	9.93	10.91	11.89	13.87	16.82	19.77	22.73	25.68	28.05	35.53	1.360	50	68
9.74	10.23	11.22	12.20	13.19	14.17	15.15	17.12	20.08	23.03	25.98	28.93	31.30	38.78	1.364	22	30
7.17	7.66	8.65	9.63	10.62	11.60	12.59	14.56	17.51	20.47	23.42	26.37	28.74	36.22	1.364	44	60
10.09	10.58	11.56	12.55	13.53	14.51	15.50	17.47	20.42	23.37	26.33	29.28	31.64	39.12	1.368	19	26
7.86	8.35	9.34	10.33	11.31	12.29	13.28	15.25	18.21	21.16	24.11	27.06	29.43	36.91	1.368	38	52
8.56	9.05	10.03	11.02	12.00	12.98	13.97	15.94	18.90	21.85	24.80	27.75	30.12	37.60	1.375	32	44
9.25	9.74	10.72	11.71	12.69	13.68	14.66	16.63	19.59	22.54	25.49	28.44	30.81	38.29	1.385	26	36
6.17	6.66	7.65	8.64	9.63	10.61	11.60	13.57	16.53	19.48	22.43	25.39	27.75	35.23	1.385	52	72
10.19	10.68	11.66	12.65	13.63	14.61	15.60	17.57	20.52	23.47	26.43	29.38	31.74	39.22	1.389	18	25
8.06	8.55	9.54	10.52	11.51	12.49	13.48	15.45	18.40	21.35	24.31	27.26	29.62	37.10	1.389	36	50
9.59	10.08	11.07	12.06	13.04	14.02	15.01	16.98	19.93	22.88	25.84	28.79	31.15	38.63	1.391	23	32
9.94	10.43	11.42	12.40	13.39	14.37	15.35	17.32	20.28	23.23	26.18	29.13	31.50	38.98	1.400	20	28
7.56	8.06	9.04	10.03	11.01	12.00	12.98	14.95	17.91	20.86	23.82	26.77	29.13	36.61	1.400	40	56
8.51	9.00	9.98	10.97	11.95	12.93	13.92	15.89	18.85	21.80	24.75	27.70	30.07	37.55	1.406	32	45
	5.15	6.15	7.14	8.13	9.12	10.10	12.08	15.04	17.99	20.95	23.90	26.27	33.75	1.406	64	90
8.26	8.75	9.73	10.72	11.71	12.69	13.67	15.64	18.60	21.55	24.51	27.46	29.82	37.30	1.412	34	48
9.45	9.94	10.92	11.91	12.89	13.87	14.86	16.83	19.78	22.73	25.69	28.64	31.00	38.48	1.417	24	34
6.57	7.06	8.05	9.03	10.02	11.00	11.99	13.96	16.92	19.87	22.83	25.78	28.14	35.63	1.417	48	68
6.92	7.41	8.39	9.38	10.37	11.35	12.34	14.31	17.27	20.22	23.17	26.12	28.49	35.97	1.422	45	64
9.79	10.28	11.27	12.25	13.24	14.22	15.20	17.17	20.13	23.08	26.03	28.98	31.35	38.83	1.429	21	30
8.95	9.44	10.43	11.41	12.40	13.38	14.36	16.33	19.29	22.24	25.20	28.15	30.51	37.99	1.429	28	40
5.56	6.06	7.05	8.04	9.03	10.01	11.00	12.97	15.93	18.88	21.84	24.79	27.16	34.64	1.429	56	80
9.30	9.79	10.77	11.76	12.74	13.72	14.71	16.68	19.64	22.59	25.54	28.49	30.86	38.34	1.440	25	36
6.26	6.76	7.75	8.73	9.72	10.70	11.69	13.66	16.62	19.57	22.53	25.48	27.85	35.33	1.440	50	72
10.14	10.63	11.61	12.60	13.58	14.56	15.55	17.52	20.47	23.42	26.38	29.33	31.69	39.17	1.444	18	26
7.96	8.45	9.44	10.42	11.41	12.39	13.37	15.35	18.30	21.25	24.21	27.16	29.53	37.01	1.444	36	52
9.64	10.13	11.12	12.10	13.09	14.07	15.05	17.02	19.98	22.93	25.89	28.84	31.20	38.68	1.455	22	32
6.96	7.45	8.44	9.43	10.42	11.40	12.38	14.36	17.31	20.27	23.22	26.17	28.54	36.02	1.455	44	64
9.15	9.64	10.62	11.61	12.59	13.58	14.56	16.53	19.49	22.44	25.39	28.34	30.71	38.19	1.462	26	38
8.65	9.14	10.13	11.11	12.10	13.08	14.07	16.04	18.99	21.94	24.90	27.85	30.21	37.70	1.467	30	44
8.16	8.65	9.63	10.62	11.61	12.59	13.57	15.54	18.50	21.45	24.41	27.36	29.72	37.20	1.471	34	50
9.99	10.48	11.46	12.45	13.43	14.41	15.40	17.37	20.33	23.28	26.23	29.18	31.55	39.03	1.474	19	28
7.66	8.15	9.14	10.12	11.11	12.09	13.08	15.05	18.01	20.96	23.91	26.86	29.23	36.71	1.474	38	56
9.49	9.98	10.97	11.96	12.94	13.92	14.91	16.88	19.83	22.78	25.74	28.69	31.05	38.53	1.478	23	34
9.84	10.33	11.32	12.30	13.29	14.27	15.25	17.22	20.18	23.13	26.08	29.03	31.40	38.88	1.500	20	30
9.34	9.83	10.82	11.81	12.79	13.77	14.76	16.73	19.68	22.63	25.59	28.54	30.90	38.39	1.500	24	36
8.60	9.09	10.08	11.06	12.05	13.03	14.02	15.99	18.94	21.89	24.85	27.80	30.16	37.65	1.500	30	45
8.35	8.84	9.83	10.82	11.80	12.78	13.77	15.74	18.70	21.65	24.60	27.55	29.92	37.40	1.500	32	48
7.36	7.85	8.84	9.82	10.81	11.79	12.78	14.75	17.71	20.66	23.62	26.57	28.93	36.41	1.500	40	60
6.36	6.85	7.84	8.83	9.82	10.80	11.79	13.76	16.72	19.67	22.63	25.58	27.94	35.43	1.500	48	72
	5.33	6.33	7.32	8.31	9.30	10.29	12.27	15.23	18.18	21.14	24.09	26.46	33.95	1.500	60	90
6.70	7.20	8.19	9.18	10.16	11.15	12.13	14.11	17.06	20.02	22.97	25.92	28.29	35.77	1.511	45	68
9.20	9.69	10.67	11.66	12.64	13.62	14.61	16.58	19.54	22.49	25.44	28.39	30.76	38.24	1.520	25	38
9.69	10.18	11.17	12.15	13.14	14.12	15.10	17.07	20.03	22.98	25.93	28.88	31.25	38.73	1.524	21	32
8.05	8.54	9.53	10.52	11.50	12.49	13.47	15.44	18.40	21.35	24.31	27.26	29.62	37.10	1.529	34	52
9.05	9.54	10.52	11.51	12.49	13.48	14.46	16.43	19.39	22.34	25.29	28.24	30.61	38.09	1.538	26	40
5.74	6.24	7.23	8.22	9.21	10.20	11.18	13.16	16.12	19.07	22.03	24.98	27.35	34.83	1.538	52	80
9.54	10.03	11.02	12.00	12.99	13.97	14.95	16.92	19.88	22.83	25.79	28.74	31.10	38.58	1.545	22	34
0.97	0.98	1.00	1.01	1.03	1.05	1.06	1.09	1.13	1.16	1.19	1.22	1.24	1.29			

*This length correction factor must be used to determine the proper belt width.

Center Distance is greater than eight times the small diameter and the large sprocket is not flanged. See Engineering Section I-10, Use of Flanged Sprockets, on page 134.



Sprocket Combinations				Speed Ratio	Center Distance, Inches												
DriveR		DriveN			5MR-300 P.L. 11.811 60 teeth	5MR-355 P.L. 13.976 71 teeth	5MR-375 P.L. 14.764 75 teeth	5MR-400 P.L. 15.748 80 teeth	5MR-405 P.L. 15.945 81 teeth	5MR-425 P.L. 16.732 85 teeth	5MR-450 P.L. 17.716 90 teeth	5MR-500 P.L. 19.685 100 teeth	5MR-535 P.L. 21.063 107 teeth	5MR-565 P.L. 22.244 113 teeth	5MR-590 P.L. 22.835 116 teeth	5MR-600 P.L. 23.622 120 teeth	
No. of Grooves	Pitch Diameter (Inches)	No. of Grooves	Pitch Diameter (Inches)														
44	2.757	68	4.261	1.545							4.26	4.96	5.56	5.85	6.25		
18	1.128	28	1.754	1.556	3.63	4.72	5.11	5.60	5.70	6.09	6.59	7.57	8.26	8.85	9.15	9.54	
36	2.256	56	3.509	1.556				3.29	3.38	3.79	4.29	5.27	5.97	6.56	6.86	7.26	
32	2.005	50	3.133	1.563		2.90	3.30	3.80	3.89	4.29	4.79	5.78	6.47	7.06	7.36	7.75	
23	1.441	36	2.256	1.565	2.97	4.07	4.46	4.95	5.05	5.45	5.94	6.92	7.62	8.21	8.50	8.90	
28	1.754	44	2.757	1.571		3.41	3.80	4.30	4.40	4.80	5.29	6.28	6.97	7.56	7.86	8.25	
19	1.191	30	1.880	1.579	3.48	4.57	4.96	5.45	5.55	5.94	6.44	7.42	8.11	8.70	9.00	9.39	
38	2.381	60	3.760	1.579						3.47	3.98	4.97	5.66	6.26	6.56	6.95	
24	1.504	38	2.381	1.583	2.82	3.91	4.31	4.80	4.90	5.30	5.79	6.77	7.47	8.06	8.35	8.75	
20	1.253	32	2.005	1.600	3.32	4.42	4.81	5.30	5.40	5.79	6.29	7.27	7.96	8.55	8.85	9.24	
25	1.566	40	2.506	1.600	2.67	3.76	4.16	4.65	4.75	5.15	5.64	6.63	7.32	7.91	8.20	8.60	
30	1.880	48	3.008	1.600		3.10	3.50	4.00	4.09	4.49	4.99	5.97	6.67	7.26	7.55	7.95	
40	2.506	64	4.010	1.600								3.66	4.66	5.36	5.95	6.25	6.65
45	2.820	72	4.511	1.600								3.99	4.70	5.29	5.59	5.99	
50	3.133	80	5.013	1.600										4.63	4.93	5.33	
28	1.754	45	2.820	1.607		3.36	3.75	4.25	4.34	4.74	5.24	6.22	6.92	7.51	7.80	8.20	
56	3.509	90	5.639	1.607													
21	1.316	34	2.130	1.619	3.17	4.26	4.66	5.15	5.25	5.64	6.14	7.12	7.81	8.40	8.70	9.09	
32	2.005	52	3.258	1.625			3.18	3.69	3.78	4.18	4.68	5.67	6.37	6.96	7.25	7.65	
22	1.379	36	2.256	1.636	3.02	4.11	4.50	5.00	5.10	5.49	5.99	6.97	7.66	8.25	8.55	8.94	
44	2.757	72	4.511	1.636								4.04	4.74	5.34	5.64	6.04	
34	2.130	56	3.509	1.647				3.38	3.47	3.87	4.38	5.37	6.06	6.66	6.95	7.35	
68	4.261	112	7.018	1.647													
23	1.441	38	2.381	1.652	2.86	3.96	4.35	4.85	4.95	5.34	5.84	6.82	7.51	8.10	8.40	8.80	
18	1.128	30	1.880	1.667	3.52	4.61	5.00	5.50	5.59	5.99	6.49	7.47	8.16	8.75	9.04	9.44	
24	1.504	40	2.506	1.667	2.71	3.81	4.20	4.70	4.79	5.19	5.69	6.67	7.36	7.95	8.25	8.65	
30	1.880	50	3.133	1.667		2.99	3.38	3.89	3.98	4.38	4.88	5.87	6.56	7.16	7.45	7.85	
36	2.256	60	3.760	1.667						3.56	4.07	5.06	5.76	6.35	6.65	7.04	
48	3.008	80	5.013	1.667										4.71	5.01	5.42	
19	1.191	32	2.005	1.684	3.37	4.46	4.85	5.35	5.44	5.84	6.34	7.32	8.01	8.60	8.90	9.29	
38	2.381	64	4.010	1.684							3.75	4.75	5.45	6.05	6.34	6.74	
26	1.629	44	2.757	1.692		3.50	3.89	4.39	4.49	4.89	5.39	6.37	7.06	7.65	7.95	8.35	
20	1.253	34	2.130	1.700	3.22	4.31	4.70	5.20	5.29	5.69	6.19	7.17	7.86	8.45	8.75	9.14	
40	2.506	68	4.261	1.700								4.44	5.14	5.74	6.04	6.44	
21	1.316	36	2.256	1.714	3.06	4.16	4.55	5.05	5.14	5.54	6.04	7.02	7.71	8.30	8.60	8.99	
28	1.754	48	3.008	1.714		3.19	3.58	4.09	4.18	4.58	5.08	6.07	6.76	7.35	7.65	8.05	
22	1.379	38	2.381	1.727	2.91	4.01	4.40	4.90	4.99	5.39	5.89	6.87	7.56	8.15	8.45	8.84	
26	1.629	45	2.820	1.731		3.44	3.84	4.34	4.44	4.83	5.33	6.32	7.01	7.60	7.90	8.29	
52	3.258	90	5.639	1.731												4.67	
30	1.880	50	3.258	1.733			3.27	3.78	3.87	4.27	4.77	5.76	6.46	7.05	7.35	7.74	
23	1.441	40	2.506	1.739	2.75	3.85	4.25	4.75	4.84	5.24	5.74	6.72	7.41	8.00	8.30	8.69	
32	2.005	56	3.509	1.750				3.46	3.56	3.96	4.47	5.46	6.15	6.75	7.04	7.44	
64	4.010	112	7.018	1.750													
25	1.566	44	2.757	1.760		3.54	3.94	4.44	4.54	4.93	5.43	6.42	7.11	7.70	8.00	8.39	
34	2.130	60	3.760	1.765						3.65	4.15	5.15	5.85	6.44	6.74	7.14	
18	1.128	32	2.005	1.778	3.42	4.51	4.90	5.40	5.49	5.89	6.38	7.37	8.06	8.65	8.94	9.34	
36	2.256	64	4.010	1.778							3.84	4.84	5.54	6.14	6.43	6.83	
45	2.820	80	5.013	1.778									4.24	4.84	5.15	5.55	
28	1.754	50	3.133	1.786		3.07	3.47	3.98	4.07	4.47	4.97	5.96	6.66	7.25	7.55	7.94	
19	1.191	34	2.130	1.789	3.26	4.36	4.75	5.25	5.34	5.74	6.23	7.22	7.91	8.50	8.79	9.19	
38	2.381	68	4.261	1.789								4.53	5.23	5.83	6.13	6.53	
20	1.253	36	2.256	1.800	3.11	4.20	4.60	5.09	5.19	5.59	6.08	7.07	7.76	8.35	8.64	9.04	
25	1.566	45	2.820	1.800		3.49	3.88	4.39	4.48	4.88	5.38	6.36	7.06	7.65	7.95	8.34	
40	2.506	72	4.511	1.800								4.21	4.92	5.52	5.82	6.22	
50	3.133	90	5.639	1.800												4.75	
21	1.316	38	2.381	1.810	2.95	4.05	4.44	4.94	5.04	5.44	5.93	6.92	7.61	8.20	8.49	8.89	
22	1.379	40	2.506	1.818	2.80	3.90	4.29	4.79	4.89	5.28	5.78	6.77	7.46	8.05	8.34	8.74	
44	2.757	80	5.013	1.818									4.28	4.89	5.19	5.59	
24	1.504	44	2.757	1.833	2.48	3.59	3.98	4.48	4.58	4.98	5.48	6.46	7.16	7.75	8.04	8.44	
26	1.629	48	3.008	1.846		3.28	3.67	4.18	4.27	4.67	5.17	6.16	6.85	7.45	7.74	8.14	
28	1.754	52	3.258	1.857		2.96	3.36	3.87	3.96	4.36	4.87	5.86	6.55	7.14	7.44	7.84	
30	1.880	56	3.509	1.867			3.04	3.55	3.65	4.05	4.55	5.55	6.24	6.84	7.14	7.53	
60	3.760	112	7.018	1.867													
24	1.504	45	2.820	1.875		3.53	3.93	4.43	4.53	4.92	5.42	6.41	7.10	7.70	7.99	8.39	
Length Factor*					0.77	0.81	0.83	0.84	0.85	0.86	0.88	0.90	0.92	0.94	0.95	0.95	

*This length factor must be used to determine the proper belt width.

Center Distance is greater than eight times the small diameter and the large sprocket is not flanged. See Engineering Section I-10, Use of Flanged Sprockets, on page 134.



Sprocket Combinations				Speed Ratio	Center Distance, Inches												
DriveR		DriveN			5MR-300 P.L. 11.811 60 teeth	5MR-355 P.L. 13.976 71 teeth	5MR-375 P.L. 14.764 75 teeth	5MR-400 P.L. 15.748 80 teeth	5MR-405 P.L. 15.945 81 teeth	5MR-425 P.L. 16.732 85 teeth	5MR-450 P.L. 17.716 90 teeth	5MR-500 P.L. 19.685 100 teeth	5MR-535 P.L. 21.063 107 teeth	5MR-565 P.L. 22.244 113 teeth	5MR-590 P.L. 22.835 116 teeth	5MR-600 P.L. 23.622 120 teeth	
No. of Grooves	Pitch Diameter (Inches)	No. of Grooves	Pitch Diameter (Inches)														
32	2.005	60	3.760	1.875				3.23	3.33	3.73	4.24	5.24	5.94	6.53	6.83	7.23	
48	3.008	90	5.639	1.875												4.84	
34	2.130	64	4.010	1.882						3.41	3.92	4.93	5.63	6.23	6.52	6.92	
18	1.128	34	2.130	1.889	3.31	4.40	4.79	5.29	5.39	5.78	6.28	7.26	7.96	8.55	8.84	9.24	
36	2.256	68	4.261	1.889							3.60	4.61	5.32	5.92	6.22	6.62	
19	1.191	36	2.256	1.895	3.15	4.25	4.64	5.14	5.24	5.63	6.13	7.11	7.80	8.40	8.69	9.09	
38	2.381	72	4.511	1.895								4.29	5.00	5.61	5.91	6.31	
20	1.253	38	2.381	1.900	3.00	4.10	4.49	4.99	5.08	5.48	5.98	6.96	7.66	8.25	8.54	8.94	
21	1.316	40	2.506	1.905	2.84	3.94	4.34	4.84	4.93	5.33	5.83	6.81	7.50	8.10	8.39	8.79	
23	1.441	44	2.757	1.913	2.52	3.63	4.03	4.53	4.63	5.02	5.52	6.51	7.20	7.80	8.09	8.49	
25	1.566	48	3.008	1.920		3.32	3.72	4.22	4.32	4.72	5.22	6.21	6.90	7.49	7.79	8.19	
26	1.629	50	3.133	1.923		3.16	3.56	4.07	4.16	4.56	5.06	6.05	6.75	7.34	7.64	8.03	
23	1.441	45	2.820	1.957	2.46	3.58	3.97	4.48	4.57	4.97	5.47	6.46	7.15	7.74	8.04	8.44	
18	1.128	36	2.256	2.000	3.20	4.30	4.69	5.19	5.28	5.68	6.18	7.16	7.85	8.44	8.74	9.13	
19	1.191	38	2.381	2.000	3.04	4.14	4.54	5.03	5.13	5.53	6.03	7.01	7.70	8.29	8.59	8.98	
20	1.253	40	2.506	2.000	2.88	3.99	4.38	4.88	4.98	5.38	5.87	6.86	7.55	8.14	8.44	8.84	
22	1.379	44	2.757	2.000	2.56	3.68	4.07	4.57	4.67	5.07	5.57	6.56	7.25	7.84	8.14	8.53	
24	1.504	48	3.008	2.000		3.36	3.76	4.26	4.36	4.76	5.26	6.25	6.95	7.54	7.84	8.23	
25	1.566	50	3.133	2.000		3.20	3.60	4.11	4.21	4.61	5.11	6.10	6.79	7.39	7.68	8.08	
26	1.629	52	3.258	2.000		3.04	3.45	3.95	4.05	4.45	4.95	5.95	6.64	7.24	7.53	7.93	
28	1.754	56	3.509	2.000			3.12	3.64	3.73	4.14	4.64	5.64	6.34	6.93	7.23	7.63	
30	1.880	60	3.760	2.000				3.31	3.41	3.82	4.33	5.33	6.03	6.62	6.92	7.32	
32	2.005	64	4.010	2.000						3.50	4.01	5.02	5.72	6.32	6.61	7.01	
34	2.130	68	4.261	2.000							3.69	4.70	5.41	6.01	6.31	6.71	
36	2.256	72	4.511	2.000								4.38	5.09	5.69	5.99	6.40	
40	2.506	80	5.013	2.000									4.45	5.06	5.36	5.77	
45	2.820	90	5.639	2.000											4.55	4.96	
56	3.509	112	7.018	2.000													
22	1.379	45	2.820	2.045	2.50	3.62	4.02	4.52	4.62	5.02	5.51	6.50	7.20	7.79	8.09	8.48	
44	2.757	90	5.639	2.045											4.59	5.01	
25	1.566	52	3.258	2.080		3.08	3.49	4.00	4.09	4.50	5.00	5.99	6.69	7.28	7.58	7.98	
24	1.504	50	3.133	2.083		3.25	3.65	4.15	4.25	4.65	5.15	6.14	6.84	7.43	7.73	8.13	
23	1.441	48	3.008	2.087		3.41	3.80	4.31	4.41	4.81	5.31	6.30	6.99	7.59	7.88	8.28	
21	1.316	44	2.757	2.095	2.61	3.72	4.12	4.62	4.72	5.12	5.61	6.60	7.30	7.89	8.18	8.58	
19	1.191	40	2.506	2.105	2.93	4.03	4.43	4.93	5.02	5.42	5.92	6.91	7.60	8.19	8.49	8.88	
38	2.381	80	5.013	2.105								4.53	5.14	5.45	5.85		
18	1.128	38	2.381	2.111	3.09	4.19	4.58	5.08	5.18	5.57	6.07	7.06	7.75	8.34	8.64	9.03	
34	2.130	72	4.511	2.118								4.46	5.18	5.78	6.08	6.48	
32	2.005	68	4.261	2.125							3.77	4.79	5.49	6.09	6.39	6.79	
30	1.880	64	4.010	2.133						3.58	4.09	5.10	5.81	6.41	6.70	7.10	
21	1.316	45	2.820	2.143	2.54	3.66	4.06	4.56	4.66	5.06	5.56	6.55	7.24	7.84	8.13	8.53	
28	1.754	60	3.760	2.143				3.40	3.49	3.90	4.41	5.42	6.12	6.71	7.01	7.41	
26	1.629	56	3.509	2.154			3.21	3.72	3.82	4.22	4.73	5.73	6.43	7.02	7.32	7.72	
52	3.258	112	7.018	2.154													
24	1.504	52	3.258	2.167		3.13	3.53	4.04	4.14	4.54	5.04	6.04	6.73	7.33	7.62	8.02	
23	1.441	50	3.133	2.174		3.29	3.69	4.20	4.29	4.70	5.20	6.19	6.89	7.48	7.78	8.17	
22	1.379	48	3.008	2.182		3.45	3.85	4.35	4.45	4.85	5.35	6.34	7.04	7.63	7.93	8.32	
20	1.253	44	2.757	2.200	2.65	3.77	4.16	4.66	4.76	5.16	5.66	6.65	7.34	7.93	8.23	8.63	
18	1.128	40	2.506	2.222	2.97	4.08	4.47	4.97	5.07	5.47	5.97	6.95	7.64	8.24	8.53	8.93	
36	2.256	80	5.013	2.222								3.88	4.61	5.23	5.53	5.94	
25	1.566	56	3.509	2.240			3.25	3.76	3.86	4.27	4.77	5.77	6.47	7.07	7.36	7.76	
50	3.133	112	7.018	2.240													
20	1.253	45	2.820	2.250	2.59	3.71	4.11	4.61	4.71	5.11	5.61	6.59	7.29	7.88	8.18	8.58	
32	2.005	72	4.511	2.250							3.52	4.55	5.26	5.87	6.17	6.57	
40	2.506	90	5.639	2.250										4.44	4.76	5.17	
23	1.441	52	3.258	2.261		3.17	3.57	4.08	4.18	4.58	5.09	6.08	6.78	7.37	7.67	8.07	
30	1.880	68	4.261	2.267							3.85	4.87	5.58	6.18	6.48	6.88	
22	1.379	50	3.133	2.273		3.33	3.73	4.24	4.34	4.74	5.24	6.23	6.93	7.53	7.82	8.22	
21	1.316	48	3.008	2.286		3.49	3.89	4.40	4.49	4.90	5.40	6.39	7.08	7.68	7.97	8.37	
28	1.754	64	4.010	2.286					3.24	3.66	4.18	5.19	5.89	6.49	6.79	7.19	
26	1.629	60	3.760	2.308				3.48	3.58	3.99	4.50	5.50	6.21	6.80	7.10	7.50	
19	1.191	44	2.757	2.316	2.69	3.81	4.21	4.71	4.81	5.21	5.71	6.69	7.39	7.98	8.28	8.67	
24	1.504	56	3.509	2.333		2.88	3.29	3.80	3.90	4.31	4.82	5.82	6.52	7.11	7.41	7.81	
48	3.008	112	7.018	2.333													
Length Factor*					0.77	0.81	0.83	0.84	0.85	0.86	0.88	0.90	0.92	0.94	0.95	0.95	

*This length factor must be used to determine the proper belt width.

Center Distance is greater than eight times the small diameter and the large sprocket is not flanged. See Engineering Section I-10, Use of Flanged Sprockets, on page 134.



Sprocket Combinations				Speed Ratio	Center Distance, Inches											
DriveR		DriveN			5MR-300 P.L. 11.811 60 teeth	5MR-355 P.L. 13.976 71 teeth	5MR-375 P.L. 14.764 75 teeth	5MR-400 P.L. 15.748 80 teeth	5MR-405 P.L. 15.945 81 teeth	5MR-425 P.L. 16.732 85 teeth	5MR-450 P.L. 17.716 90 teeth	5MR-500 P.L. 19.685 100 teeth	5MR-535 P.L. 21.063 107 teeth	5MR-565 P.L. 22.244 113 teeth	5MR-590 P.L. 22.835 116 teeth	5MR-600 P.L. 23.622 120 teeth
No. of Grooves	Pitch Diameter (Inches)	No. of Grooves	Pitch Diameter (Inches)													
34	2.130	80	5.013	2.353							3.96	4.70	5.31	5.62	6.03	
22	1.379	52	3.258	2.364							6.13	6.82	7.42	7.72	8.11	
19	1.191	45	2.820	2.368	2.63	3.21	3.62	4.13	4.22	4.63	5.13	5.65	6.64	7.33	8.22	
38	2.381	90	5.639	2.368										4.52	4.84	5.26
21	1.316	50	3.133	2.381		3.37	3.78	4.28	4.38	4.78	5.29	6.28	6.98	7.57	7.87	8.27
20	1.253	48	3.008	2.400		3.53	3.94	4.44	4.54	4.94	5.44	6.43	7.13	7.72	8.02	8.42
25	1.566	60	3.760	2.400			2.99	3.52	3.62	4.03	4.54	5.55	6.25	6.85	7.15	7.55
30	1.880	72	4.511	2.400							3.60	4.63	5.35	5.95	6.26	6.66
28	1.754	68	4.261	2.429						3.41	3.93	4.96	5.67	6.27	6.57	6.97
23	1.441	56	3.509	2.435		2.92	3.33	3.85	3.95	4.35	4.86	5.86	6.56	7.16	7.46	7.85
18	1.128	44	2.757	2.444	2.73	3.85	4.25	4.75	4.85	5.25	5.75	6.74	7.43	8.03	8.32	8.72
26	1.629	64	4.010	2.462				3.22	3.33	3.75	4.26	5.28	5.98	6.58	6.88	7.28
21	1.316	52	3.258	2.476		3.25	3.66	4.17	4.27	4.67	5.18	6.17	6.87	7.46	7.76	8.16
45	2.820	112	7.018	2.489												
18	1.128	45	2.820	2.500	2.67	3.79	4.19	4.70	4.79	5.20	5.70	6.69	7.38	7.97	8.27	8.67
20	1.253	50	3.133	2.500		3.42	3.82	4.33	4.43	4.83	5.33	6.33	7.02	7.62	7.91	8.31
24	1.504	60	3.760	2.500			3.03	3.56	3.66	4.07	4.59	5.59	6.29	6.89	7.19	7.59
32	2.005	80	5.013	2.500								4.05	4.78	5.40	5.70	6.11
36	2.256	90	5.639	2.500										4.60	4.92	5.34
19	1.191	48	3.008	2.526	2.44	3.58	3.98	4.48	4.58	4.98	5.49	6.48	7.17	7.77	8.07	8.46
22	1.379	56	3.509	2.545		2.96	3.37	3.89	3.99	4.40	4.90	5.90	6.60	7.20	7.50	7.90
44	2.757	112	7.018	2.545												
25	1.566	64	4.010	2.560				3.26	3.37	3.79	4.31	5.32	6.03	6.63	6.93	7.33
28	1.754	72	4.511	2.571							3.68	4.72	5.43	6.04	6.34	6.75
20	1.253	52	3.258	2.600		3.29	3.70	4.21	4.31	4.72	5.22	6.22	6.91	7.51	7.81	8.21
23	1.441	60	3.760	2.609			3.07	3.60	3.70	4.12	4.63	5.64	6.34	6.94	7.24	7.64
26	1.629	68	4.261	2.615						3.49	4.02	5.04	5.75	6.36	6.66	7.06
19	1.191	50	3.133	2.632		3.46	3.86	4.37	4.47	4.87	5.38	6.37	7.07	7.66	7.96	8.36
34	2.130	90	5.639	2.647										4.69	5.00	5.42
18	1.128	48	3.008	2.667	2.48	3.62	4.02	4.53	4.63	5.03	5.53	6.52	7.22	7.81	8.11	8.51
21	1.316	56	3.509	2.667		3.00	3.41	3.93	4.03	4.44	4.95	5.95	6.65	7.25	7.55	7.94
24	1.504	64	4.010	2.667				3.30	3.41	3.83	4.35	5.36	6.07	6.67	6.97	7.37
30	1.880	80	5.013	2.667								4.13	4.86	5.48	5.79	6.20
25	1.566	68	4.261	2.720						3.53	4.06	5.08	5.80	6.40	6.70	7.11
22	1.379	60	3.760	2.727			3.11	3.64	3.74	4.16	4.67	5.68	6.38	6.98	7.28	7.68
19	1.191	52	3.258	2.737		3.33	3.74	4.25	4.35	4.76	5.26	6.26	6.96	7.55	7.85	8.25
26	1.629	72	4.511	2.769						3.76	4.80	5.52	6.13	6.43	6.84	7.24
18	1.128	50	3.133	2.778		3.50	3.90	4.41	4.51	4.92	5.42	6.41	7.11	7.71	8.01	8.40
23	1.441	64	4.010	2.783				3.34	3.45	3.87	4.39	5.41	6.11	6.72	7.02	7.42
20	1.253	56	3.509	2.800		3.04	3.45	3.97	4.07	4.48	4.99	5.99	6.69	7.29	7.59	7.99
40	2.506	112	7.018	2.800												
32	2.005	90	5.639	2.813								4.12	4.77	5.08	5.50	
24	1.504	68	4.261	2.833								5.84	6.44	6.75	7.15	7.55
21	1.316	60	3.760	2.857			3.15	3.68	3.78	4.20	4.71	5.72	6.43	7.03	7.33	7.73
28	1.754	80	5.013	2.857								4.21	4.94	5.56	5.87	6.28
25	1.566	72	4.511	2.880						3.25	3.80	4.84	5.56	6.17	6.47	6.88
18	1.128	52	3.258	2.889		3.38	3.78	4.30	4.40	4.80	5.31	6.31	7.00	7.60	7.90	8.30
22	1.379	64	4.010	2.909				3.38	3.49	3.91	4.43	5.45	6.16	6.76	7.06	7.46
19	1.191	56	3.509	2.947		3.08	3.49	4.02	4.11	4.52	5.03	6.04	6.74	7.34	7.64	8.03
38	2.381	112	7.018	2.947												
23	1.441	68	4.261	2.957					3.17	3.61	4.14	5.17	5.88	6.49	6.79	7.19
20	1.253	60	3.760	3.000			3.19	3.72	3.83	4.24	4.76	5.77	6.47	7.07	7.37	7.77
24	1.504	72	4.511	3.000						3.29	3.84	4.88	5.60	6.21	6.52	6.92
30	1.880	90	5.639	3.000								4.20	4.85	5.16	5.59	5.99
21	1.316	64	4.010	3.048				3.42	3.53	3.95	4.47	5.49	6.20	6.80	7.10	7.51
26	1.629	80	5.013	3.077								4.28	5.03	5.65	5.96	6.37
22	1.379	68	4.261	3.091					3.21	3.65	4.18	5.21	5.92	6.53	6.83	7.24
18	1.128	56	3.509	3.111		3.12	3.54	4.06	4.16	4.57	5.08	6.08	6.78	7.38	7.68	8.08
36	2.256	112	7.018	3.111												
23	1.441	72	4.511	3.130						3.33	3.88	4.92	5.65	6.26	6.56	6.97
19	1.191	60	3.760	3.158		2.80	3.23	3.77	3.87	4.28	4.80	5.81	6.51	7.12	7.41	7.82
20	1.253	64	4.010	3.200				3.46	3.57	3.99	4.51	5.53	6.24	6.85	7.15	7.55
25	1.566	80	5.013	3.200								4.32	5.07	5.69	6.00	6.41
28	1.754	90	5.639	3.214									4.27	4.93	5.24	5.67
Length Factor*					0.77	0.81	0.83	0.84	0.85	0.86	0.88	0.90	0.92	0.94	0.95	0.95

*This length factor must be used to determine the proper belt width.

Center Distance is greater than eight times the small diameter and the large sprocket is not flanged. See Engineering Section I-10, Use of Flanged Sprockets, on page 134.



Sprocket Combinations				Speed Ratio	Center Distance, Inches											
DriveR		DriveN			5MR-300 P.L. 11.811 60 teeth	5MR-355 P.L. 13.976 71 teeth	5MR-375 P.L. 14.764 75 teeth	5MR-400 P.L. 15.748 80 teeth	5MR-405 P.L. 15.945 81 teeth	5MR-425 P.L. 16.732 85 teeth	5MR-450 P.L. 17.716 90 teeth	5MR-500 P.L. 19.685 100 teeth	5MR-535 P.L. 21.063 107 teeth	5MR-565 P.L. 22.244 113 teeth	5MR-590 P.L. 22.835 116 teeth	5MR-600 P.L. 23.622 120 teeth
No. of Grooves	Pitch Diameter (Inches)	No. of Grooves	Pitch Diameter (Inches)													
21	1.316	68	4.261	3.238				3.14	3.25	3.69	4.22	5.25	5.97	6.57	6.88	7.28
22	1.379	72	4.511	3.273						3.37	3.92	4.96	5.69	6.30	6.60	7.01
34	2.130	112	7.018	3.294												
18	1.128	60	3.760	3.333		2.84	3.27	3.81	3.91	4.32	4.84	5.85	6.56	7.16	7.46	7.86
24	1.504	80	5.013	3.333								4.36	5.11	5.73	6.04	6.45
19	1.191	64	4.010	3.368			2.95	3.50	3.61	4.03	4.56	5.58	6.29	6.89	7.19	7.59
20	1.253	68	4.261	3.400				3.18	3.29	3.73	4.26	5.29	6.01	6.62	6.92	7.32
21	1.316	72	4.511	3.429						3.41	3.96	5.01	5.73	6.34	6.65	7.05
26	1.629	90	5.639	3.462									4.35	5.00	5.32	5.75
23	1.441	80	5.013	3.478								4.40	5.15	5.77	6.08	6.49
32	2.005	112	7.018	3.500												
18	1.128	64	4.010	3.556			2.99	3.54	3.65	4.07	4.60	5.62	6.33	6.93	7.24	7.64
19	1.191	68	4.261	3.579				3.22	3.33	3.77	4.30	5.34	6.05	6.66	6.96	7.37
20	1.253	72	4.511	3.600						3.45	4.00	5.05	5.77	6.38	6.69	7.10
25	1.566	90	5.639	3.600									4.39	5.04	5.36	5.79
22	1.379	80	5.013	3.636								4.44	5.19	5.81	6.12	6.54
30	1.880	112	7.018	3.733												
24	1.504	90	5.639	3.750									4.43	5.08	5.40	5.83
18	1.128	68	4.261	3.778				3.26	3.37	3.81	4.34	5.38	6.10	6.70	7.01	7.41
19	1.191	72	4.511	3.789					3.02	3.48	4.04	5.09	5.81	6.43	6.73	7.14
21	1.316	80	5.013	3.810							3.37	4.48	5.23	5.85	6.16	6.58
23	1.441	90	5.639	3.913									4.47	5.12	5.44	5.87
18	1.128	72	4.511	4.000					3.06	3.52	4.07	5.13	5.86	6.47	6.77	7.18
20	1.253	80	5.013	4.000							3.41	4.52	5.27	5.90	6.21	6.62
28	1.754	112	7.018	4.000												
22	1.379	90	5.639	4.091								3.70	4.50	5.16	5.48	5.91
19	1.191	80	5.013	4.211							3.44	4.56	5.31	5.94	6.25	6.66
21	1.316	90	5.639	4.286								3.73	4.54	5.20	5.52	5.95
26	1.629	112	7.018	4.308												
18	1.128	80	5.013	4.444							3.48	4.60	5.35	5.98	6.29	6.70
25	1.566	112	7.018	4.480												
20	1.253	90	5.639	4.500								3.77	4.58	5.24	5.56	5.99
24	1.504	112	7.018	4.667												
19	1.191	90	5.639	4.737								3.81	4.62	5.28	5.60	6.03
23	1.441	112	7.018	4.870												
18	1.128	90	5.639	5.000								3.84	4.66	5.32	5.64	6.07
22	1.379	112	7.018	5.091												
21	1.316	112	7.018	5.333												
20	1.253	112	7.018	5.600												4.31
19	1.191	112	7.018	5.895												4.34
18	1.128	112	7.018	6.222												4.38
Length Factor*					0.77	0.81	0.83	0.84	0.85	0.86	0.88	0.90	0.92	0.94	0.95	0.95

*This length factor must be used to determine the proper belt width.

Teeth in Mesh Factor: 1.0 0.8 0.6

Center Distance is greater than eight times the small diameter and the large sprocket is not flanged. See Engineering Section I-10, Use of Flanged Sprockets, on page 134.



Center Distance, Inches														Sprocket Combinations		
														DriveR		DriveN
5MR-625 P.L. 24.606 125 teeth	5MR-660 P.L. 25.580 130 teeth	5MR-700 P.L. 27.559 140 teeth	5MR-750 P.L. 29.528 150 teeth	5MR-800 P.L. 31.496 160 teeth	5MR-850 P.L. 33.465 170 teeth	5MR-900 P.L. 35.433 180 teeth	5MR-1000 P.L. 39.370 200 teeth	5MR-1150 P.L. 45.276 230 teeth	5MR-1300 P.L. 51.181 260 teeth	5MR-1450 P.L. 57.087 290 teeth	5MR-1600 P.L. 62.992 320 teeth	5MR-1700 P.L. 67.716 344 teeth	5MR-2100 P.L. 82.677 420 teeth	Speed Ratio	No. of grooves	No. of grooves
7.79	8.28	9.28	10.28	11.27	12.26	13.25	15.23	18.20	21.16	24.12	27.07	29.44	36.93	3.238	21	68
7.52	8.02	9.02	10.02	11.01	12.00	12.99	14.98	17.95	20.91	23.87	26.82	29.19	36.68	3.273	22	72
	5.00	6.10	7.16	8.20	9.22	10.24	12.26	15.26	18.24	21.22	24.19	26.56	34.07	3.294	34	112
8.36	8.86	9.85	10.85	11.84	12.82	13.81	15.79	18.75	21.71	24.67	27.62	29.99	37.48	3.333	18	60
6.96	7.47	8.48	9.48	10.48	11.48	12.47	14.46	17.43	20.40	23.36	26.32	28.69	36.18	3.333	24	80
8.10	8.59	9.59	10.59	11.58	12.57	13.56	15.54	18.50	21.46	24.42	27.37	29.74	36.68	3.368	19	64
7.83	8.33	9.33	10.32	11.32	12.31	13.30	15.28	18.25	21.21	24.17	27.12	29.49	36.98	3.400	20	68
7.56	8.06	9.06	10.06	11.06	12.05	13.04	15.02	17.99	20.95	23.92	26.87	29.24	36.73	3.429	21	72
6.27	6.79	7.81	8.83	9.84	10.84	11.84	13.83	16.81	19.78	22.75	25.71	28.08	35.58	3.462	26	90
7.01	7.51	8.52	9.53	10.53	11.52	12.52	14.51	17.48	20.44	23.41	26.37	28.74	36.23	3.478	23	80
	5.08	6.18	7.24	8.28	9.30	10.32	12.34	15.35	18.33	21.31	24.28	26.66	34.16	3.500	32	112
8.14	8.64	9.64	10.63	11.63	12.61	13.60	15.58	18.55	21.51	24.47	27.42	29.79	37.28	3.556	18	64
7.87	8.37	9.37	10.37	11.36	12.35	13.34	15.33	18.29	21.25	24.21	27.17	29.54	37.03	3.579	19	68
7.60	8.10	9.11	10.11	11.10	12.09	13.09	15.07	18.04	21.00	23.96	26.92	29.29	36.78	3.600	20	72
6.31	6.83	7.86	8.87	9.88	10.88	11.88	13.88	16.86	19.83	22.80	25.76	28.13	35.62	3.600	25	90
7.05	7.56	8.57	9.57	10.57	11.57	12.56	14.55	17.53	20.49	23.45	26.41	28.78	36.27	3.636	22	80
	5.15	6.26	7.32	8.36	9.39	10.41	12.43	15.44	18.42	21.40	24.37	26.75	34.26	3.733	30	112
6.36	6.87	7.90	8.91	9.92	10.92	11.93	13.92	16.90	19.87	22.84	25.80	28.17	35.67	3.750	24	90
7.92	8.42	9.42	10.41	11.41	12.40	13.39	15.37	18.34	21.30	24.26	27.22	29.59	37.07	3.778	18	68
7.65	8.15	9.15	10.15	11.15	12.14	13.13	15.12	18.09	21.05	24.01	26.97	29.33	36.82	3.789	19	72
7.09	7.60	8.61	9.62	10.62	11.61	12.61	14.60	17.57	20.54	23.50	26.46	28.83	36.32	3.810	21	80
6.40	6.91	7.94	8.96	9.97	10.97	11.97	13.97	16.95	19.92	22.89	25.85	28.22	35.72	3.913	23	90
7.69	8.19	9.20	10.20	11.19	12.18	13.18	15.16	18.13	21.09	24.06	27.01	29.38	36.87	4.000	18	72
7.13	7.64	8.65	9.66	10.66	11.66	12.65	14.64	17.62	20.58	23.55	26.51	28.88	36.37	4.000	20	80
4.65	5.23	6.34	7.40	8.45	9.47	10.49	12.52	15.53	18.51	21.49	24.46	26.84	34.35	4.000	28	112
6.44	6.95	7.98	9.00	10.01	11.01	12.01	14.01	16.99	19.96	22.93	25.90	28.27	35.76	4.091	22	90
7.18	7.68	8.70	9.70	10.71	11.70	12.70	14.69	17.66	20.63	23.59	26.55	28.92	36.42	4.211	19	80
6.48	7.00	8.02	9.04	10.05	11.06	12.06	14.06	17.04	20.01	22.98	25.94	28.32	35.81	4.286	21	90
4.72	5.30	6.41	7.48	8.53	9.56	10.58	12.60	15.62	18.60	21.59	24.56	26.93	34.44	4.308	26	112
7.22	7.73	8.74	9.75	10.75	11.75	12.74	14.73	17.71	20.68	23.64	26.60	28.97	36.47	4.444	18	80
4.76	5.34	6.45	7.52	8.57	9.60	10.62	12.65	15.66	18.65	21.63	24.60	26.98	34.49	4.480	25	112
6.52	7.04	8.07	9.09	10.10	11.10	12.10	14.10	17.09	20.06	23.03	25.99	28.36	35.86	4.500	20	90
4.79	5.38	6.49	7.56	8.61	9.64	10.66	12.69	15.70	18.69	21.68	24.65	27.03	34.54	4.667	24	112
6.56	7.08	8.11	9.13	10.14	11.14	12.15	14.15	17.13	20.10	23.07	26.04	28.41	35.91	4.737	19	90
4.83	5.42	6.53	7.60	8.65	9.68	10.71	12.73	15.75	18.74	21.72	24.69	27.07	34.58	4.870	23	112
6.60	7.12	8.15	9.17	10.18	11.19	12.19	14.19	17.18	20.15	23.12	26.08	28.46	35.95	5.000	18	90
4.87	5.45	6.57	7.64	8.69	9.72	10.75	12.78	15.79	18.78	21.77	24.74	27.12	34.63	5.091	22	112
4.90	5.49	6.61	7.68	8.73	9.77	10.79	12.82	15.84	18.83	21.81	24.79	27.16	34.68	5.333	21	112
4.94	5.53	6.65	7.72	8.78	9.81	10.83	12.86	15.88	18.87	21.86	24.83	27.21	34.72	5.600	20	112
4.98	5.57	6.69	7.76	8.82	9.85	10.88	12.91	15.93	18.92	21.90	24.88	27.26	34.77	5.895	19	112
5.01	5.60	6.73	7.80	8.86	9.89	10.92	12.95	15.97	18.96	21.95	24.92	27.30	34.82	6.222	18	112
0.97	0.98	1.00	1.01	1.03	1.05	1.06	1.09	1.13	1.16	1.19	1.22	1.24	1.29			

*This length factor must be used to determine the proper belt width.

Teeth in Mesh Factor: 1.0 0.8 0.6

Center Distance is greater than eight times the small diameter and the large sprocket is not flanged. See Engineering Section I-10, Use of Flanged Sprockets, on page 134.

8mm Pitch PowerGrip® GT² Belts

Drive Selection Table

Sprocket Combinations				Speed Ratio	Center Distance, Inches															
DriveR		DriveN			384-9MGT P.L. 15.118 48 teeth	480-9MGT P.L. 19.988 60 teeth	560-9MGT P.L. 22.047 70 teeth	600-9MGT P.L. 23.622 75 teeth	640-9MGT P.L. 25.197 80 teeth	720-9MGT P.L. 28.346 90 teeth	800-9MGT P.L. 31.496 100 teeth	840-9MGT P.L. 33.071 105 teeth	880-9MGT P.L. 34.646 110 teeth	920-9MGT P.L. 36.220 115 teeth	960-9MGT P.L. 37.795 120 teeth	1040-9MGT P.L. 40.945 130 teeth	1064-9MGT P.L. 41.880 133 teeth	1120-9MGT P.L. 44.094 140 teeth	1160-9MGT P.L. 45.569 145 teeth	
No. of Grooves	Pitch Diameter (Inches)	No. of Grooves	Pitch Diameter (Inches)																	
28	2.807	38	3.810	1.357																
22	2.206	30	3.008	1.364	3.44															
32	3.208	44	4.411	1.375																
26	2.607	36	3.609	1.385		4.54														
40	4.010	56	5.614	1.400																
80	8.020	112	11.229	1.400																
64	6.416	90	9.023	1.406																
34	3.409	48	4.812	1.412																
24	2.406	34	3.409	1.417																
28	2.807	40	4.010	1.429																
56	5.614	80	8.020	1.429																
22	2.206	32	3.208	1.455																
44	4.411	64	6.416	1.455																
26	2.607	38	3.810	1.462																
30	3.008	44	4.411	1.467																
38	3.810	56	5.614	1.474																
24	2.406	36	3.609	1.500																
32	3.208	48	4.812	1.500																
48	4.812	72	7.218	1.500																
26	2.607	40	4.010	1.538																
22	2.206	34	3.409	1.545																
36	3.609	56	5.614	1.556																
72	7.218	112	11.229	1.556																
28	2.807	44	4.411	1.571																
24	2.406	38	3.810	1.583																
30	3.008	48	4.812	1.600																
40	4.010	64	6.416	1.600																
56	5.614	90	9.023	1.607																
22	2.206	36	3.609	1.636																
44	4.411	72	7.218	1.636																
34	3.409	56	5.614	1.647																
24	2.406	40	4.010	1.667																
48	4.812	80	8.020	1.667																
38	3.810	64	6.416	1.684																
26	2.607	44	4.411	1.692																
28	2.807	48	4.812	1.714																
22	2.206	38	3.810	1.727																
32	3.208	56	5.614	1.750																
64	6.416	112	11.229	1.750																
36	3.609	64	6.416	1.778																
40	4.010	72	7.218	1.800																
80	8.020	144	14.437	1.800																
22	2.206	40	4.010	1.818																
44	4.411	80	8.020	1.818																
24	2.406	44	4.411	1.833																
26	2.607	48	4.812	1.846																
30	3.008	56	5.614	1.867																
48	4.812	90	9.023	1.875																
34	3.409	64	6.416	1.882																
38	3.810	72	7.218	1.895																
22	2.206	44	4.411	2.000																
24	2.406	48	4.812	2.000																
28	2.807	56	5.614	2.000																
32	3.208	64	6.416	2.000																
36	3.609	72	7.218	2.000																
40	4.010	80	8.020	2.000																
56	5.614	112	11.229	2.000																
72	7.218	144	14.437	2.000																
44	4.411	90	9.023	2.045																
38	3.810	80	8.020	2.105																
34	3.409	72	7.218	2.118																
30	3.008	64	6.416	2.133																
26	2.607	56	5.614	2.154																
22	2.206	48	4.812	2.182																
Length Factor*					0.70	0.80	0.80	0.80	0.90	0.90	0.90	0.90	0.90	1.00	1.00	1.00	1.00	1.00	1.00	

*This length factor must be used to determine the proper belt width.

Center Distance is greater than eight times the small diameter and the large sprocket is not flanged. See Engineering Section I-10, Use of Flanged Sprockets, on page 134.



Sprocket Combinations				Speed Ratio	Center Distance, Inches															
DriveR		DriveN			384-8MGT P.L. 15.118 48 teeth	480-8MGT P.L. 19.998 60 teeth	560-8MGT P.L. 22.047 70 teeth	600-8MGT P.L. 23.622 75 teeth	640-8MGT P.L. 25.197 80 teeth	720-8MGT P.L. 28.346 90 teeth	800-8MGT P.L. 31.496 100 teeth	840-8MGT P.L. 33.071 105 teeth	880-8MGT P.L. 34.646 110 teeth	920-8MGT P.L. 36.220 115 teeth	960-8MGT P.L. 37.795 120 teeth	1040-8MGT P.L. 40.945 130 teeth	1064-8MGT P.L. 41.890 133 teeth	1120-8MGT P.L. 44.094 140 teeth	1160-8MGT P.L. 45.669 145 teeth	
No. of Grooves	Pitch Diameter (Inches)	No. of Grooves	Pitch Diameter (Inches)																	
36	3.609	80	8.020	2.222																
32	3.208	72	7.218	2.250																
40	4.010	90	9.023	2.250																
64	6.416	144	14.437	2.250																
28	2.807	64	6.416	2.286																
24	2.406	56	5.614	2.333																
48	4.812	112	11.229	2.333																
34	3.409	80	8.020	2.353																
38	3.810	90	9.023	2.368																
30	3.008	72	7.218	2.400																
26	2.607	64	6.416	2.462																
32	3.208	80	8.020	2.500																
36	3.609	90	9.023	2.500																
22	2.206	56	5.614	2.545																
44	4.411	112	11.229	2.545																
28	2.807	72	7.218	2.571																
56	5.614	144	14.437	2.571																
34	3.409	90	9.023	2.647																
24	2.406	64	6.416	2.667																
30	3.008	80	8.020	2.667																
26	2.607	72	7.218	2.769																
40	4.010	112	11.229	2.800																
32	3.208	90	9.023	2.813																
28	2.807	80	8.020	2.857																
22	2.206	64	6.416	2.909																
38	3.810	112	11.229	2.947																
24	2.406	72	7.218	3.000																
30	3.008	90	9.023	3.000																
48	4.812	144	14.437	3.000																
26	2.607	80	8.020	3.077																
36	3.609	112	11.229	3.111																
28	2.807	90	9.023	3.214																
22	2.206	72	7.218	3.273																
44	4.411	144	14.437	3.273																
34	3.409	112	11.229	3.294																
24	2.406	80	8.020	3.333																
26	2.607	90	9.023	3.462																
32	3.208	112	11.229	3.500																
40	4.010	144	14.437	3.600																
22	2.206	80	8.020	3.636																
30	3.008	112	11.229	3.733																
24	2.406	90	9.023	3.750																
38	3.810	144	14.437	3.789																
28	2.807	112	11.229	4.000																
36	3.609	144	14.437	4.000																
22	2.206	90	9.023	4.091																
34	3.409	144	14.437	4.235																
26	2.607	112	11.229	4.308																
32	3.208	144	14.437	4.500																
24	2.406	112	11.229	4.667																
30	3.008	144	14.437	4.800																
22	2.206	112	11.229	5.091																
28	2.807	144	14.437	5.143																
26	2.607	144	14.437	5.538																
24	2.406	144	14.437	6.000																
22	2.206	144	14.437	6.545																
Length Factor*				0.70	0.80	0.80	0.80	0.90	0.90	0.90	0.90	0.90	1.00	1.00	1.00	1.00	1.00	1.00	1.00	

*This length factor must be used to determine the proper belt width.

Center Distance is greater than eight times the small diameter and the large sprocket is not flanged. See Engineering Section I-10, Use of Flanged Sprockets, on page 134.

14mm Pitch PowerGrip® GT² Belts

Drive Selection Table

Sprocket Combinations				Speed Ratio	Center Distance, Inches									
DriveR		DriveN			96-14MGT P.L. 38.031 69 teeth	119-14MGT P.L. 46.850 85 teeth	140-14MGT P.L. 55.116 100 teeth	161-14MGT P.L. 63.386 115 teeth	177-14MGT P.L. 70.800 127 teeth	189-14MGT P.L. 74.409 135 teeth	210-14MGT P.L. 82.877 150 teeth	231-14MGT P.L. 90.945 165 teeth	245-14MGT P.L. 96.457 175 teeth	259-14MGT P.L. 101.968 185 teeth
No. of Grooves	Pitch Diameter (Inches)	No. of Grooves	Pitch Diameter (Inches)											
28	4.912	28	4.912	1.000	11.30	15.71	19.84	23.98	27.28	29.49	33.62	37.75	40.51	43.27
29	5.088	29	5.088	1.000	11.02	15.43	19.57	23.70	27.01	29.21	33.35	37.48	40.24	42.99
30	5.263	30	5.263	1.000	10.75	15.16	19.29	23.43	26.73	28.94	33.07	37.20	39.96	42.72
32	5.614	32	5.614	1.000	10.20	14.61	18.74	22.88	26.18	28.39	32.52	36.65	39.41	42.17
34	5.965	34	5.965	1.000	9.65	14.06	18.19	22.33	25.63	27.84	31.97	36.10	38.86	41.62
36	6.316	36	6.316	1.000	9.09	13.50	17.64	21.77	25.08	27.28	31.42	35.55	38.31	41.06
38	6.667	38	6.667	1.000	8.54	12.95	17.09	21.22	24.53	26.73	30.87	35.00	37.76	40.51
40	7.018	40	7.018	1.000	7.99	12.40	16.54	20.67	23.98	26.18	30.32	34.45	37.21	39.96
44	7.720	44	7.720	1.000		11.30	15.43	19.57	22.87	25.08	29.21	33.34	36.10	38.86
48	8.421	48	8.421	1.000		10.20	14.33	18.47	21.77	23.98	28.11	32.24	35.00	37.76
52	9.123	52	9.123	1.000			13.23	17.36	20.67	22.87	27.01	31.14	33.90	36.65
56	9.825	56	9.825	1.000			12.13	16.26	19.57	21.77	25.91	30.04	32.80	35.55
60	10.527	60	10.527	1.000				15.16	18.46	20.67	24.80	28.93	31.69	34.45
64	11.229	64	11.229	1.000				14.06	17.36	19.57	23.70	27.83	30.59	33.35
68	11.930	68	11.930	1.000				12.96	16.26	18.47	22.60	26.73	29.49	32.25
72	12.632	72	12.632	1.000					15.16	17.36	21.50	25.63	28.39	31.14
80	14.036	80	14.036	1.000						15.16	19.29	23.42	26.18	28.94
29	5.088	30	5.263	1.034	10.88	15.30	19.43	23.57	26.87	29.08	33.21	37.34	40.10	42.86
28	4.912	29	5.088	1.036	11.16	15.57	19.71	23.84	27.15	29.35	33.49	37.62	40.38	43.13
38	6.667	40	7.018	1.053	8.26	12.68	16.81	20.95	24.25	26.46	30.59	34.72	37.48	40.24
36	6.316	38	6.667	1.056	8.82	13.23	17.36	21.50	24.80	27.01	31.14	35.27	38.03	40.79
34	5.965	36	6.316	1.059	9.37	13.78	17.91	22.05	25.35	27.56	31.69	35.82	38.58	41.34
68	11.930	72	12.632	1.059				15.71	17.91	19.12	22.05	26.18	28.94	31.69
32	5.614	34	5.965	1.063	9.92	14.33	18.47	22.60	25.91	28.11	32.25	36.38	39.14	41.89
64	11.229	68	11.930	1.063				13.50	16.81	19.01	23.15	27.28	30.04	32.79
30	5.263	32	5.614	1.067	10.47	14.88	19.02	23.15	26.46	28.66	32.80	36.93	39.69	42.44
60	10.527	64	11.229	1.067				14.60	17.91	20.11	24.25	28.38	31.14	33.90
28	4.912	30	5.263	1.071	11.02	15.43	19.57	23.70	27.01	29.21	33.35	37.48	40.24	42.99
56	9.825	60	10.527	1.071				11.57	15.71	19.01	23.15	27.28	30.04	32.79
52	9.123	56	9.825	1.077				12.67	16.81	20.12	24.26	28.39	31.14	33.90
48	8.421	52	9.123	1.083		9.64	13.78	17.91	21.22	23.42	27.56	31.69	34.45	37.20
44	7.720	48	8.421	1.091		10.74	14.88	19.01	22.32	24.53	28.66	32.79	35.55	38.31
40	7.018	44	7.720	1.100		11.84	15.98	20.12	23.42	25.63	29.76	33.89	36.65	39.41
29	5.088	32	5.614	1.103	10.61	15.02	19.15	23.29	26.59	28.80	32.93	37.06	39.82	42.58
36	6.316	40	7.018	1.111	8.54	12.95	17.08	21.22	24.52	26.73	30.87	35.00	37.76	40.51
72	12.632	80	14.036	1.111					14.04	16.24	20.38	24.51	27.28	30.03
34	5.965	38	6.667	1.118	9.09	13.50	17.64	21.77	25.08	27.28	31.42	35.55	38.31	41.06
32	5.614	36	6.316	1.125	9.64	14.05	18.19	22.32	25.63	27.83	31.97	36.10	38.86	41.61
64	11.229	72	12.632	1.125				12.94	16.24	18.45	22.59	26.72	29.48	32.24
80	14.036	90	15.790	1.125							17.89	22.03	24.79	27.55
30	5.263	34	5.965	1.133	10.19	14.60	18.74	22.87	26.18	28.38	32.52	36.65	39.41	42.17
60	10.527	68	11.930	1.133				14.04	17.35	19.55	23.69	27.82	30.58	33.34
28	4.912	32	5.614	1.143	10.74	15.15	19.29	23.43	26.73	28.94	33.07	37.20	39.96	42.72
56	9.825	64	11.229	1.143				15.14	18.45	20.66	24.79	28.93	31.69	34.44
52	9.123	60	10.527	1.154				12.11	16.25	19.55	23.69	27.82	30.58	33.34
38	6.667	44	7.720	1.158		12.11	16.25	20.39	23.69	25.90	30.04	34.17	36.93	39.68
48	8.421	56	9.825	1.167			13.21	17.35	20.66	22.86	27.00	31.13	33.89	36.65
29	5.088	34	5.965	1.172	10.32	14.74	18.87	23.01	26.32	28.52	32.66	36.79	39.55	42.30
34	5.965	40	7.018	1.176	8.80	13.22	17.36	21.49	24.80	27.00	31.14	35.27	38.03	40.78
68	11.930	80	14.036	1.176					14.57	16.78	20.92	25.05	27.82	30.57
44	7.720	52	9.123	1.182		10.17	14.31	18.45	21.76	23.97	28.10	32.23	34.99	37.75
32	5.614	38	6.667	1.188	9.35	13.77	17.91	22.04	25.35	27.55	31.69	35.82	38.58	41.34
30	5.263	36	6.316	1.200	9.91	14.32	18.46	22.59	25.90	28.11	32.24	36.37	39.13	41.89
40	7.018	48	8.421	1.200		11.28	15.42	19.56	22.86	25.07	29.21	33.34	36.10	38.85
60	10.527	72	12.632	1.200				13.46	16.78	18.99	23.13	27.26	30.02	32.78
28	4.912	34	5.965	1.214	10.46	14.87	19.01	23.15	26.45	28.66	32.79	36.92	39.68	42.44
56	9.825	68	11.930	1.214				14.57	17.88	20.09	24.23	28.36	31.13	33.88
36	6.316	44	7.720	1.222	7.96	12.38	16.52	20.66	23.97	26.17	30.31	34.44	37.20	39.95
52	9.123	64	11.229	1.231				11.53	15.68	18.99	23.13	27.26	30.02	32.78
29	5.088	36	6.316	1.241	10.04	14.46	18.59	22.73	26.04	28.24	32.38	36.51	39.27	42.02
32	5.614	40	7.018	1.250	9.07	13.49	17.62	21.76	25.07	27.27	31.41	35.54	38.30	41.06
48	8.421	60	10.527	1.250				12.63	16.78	20.09	24.23	28.36	31.13	33.88
64	11.229	80	14.036	1.250					15.09	17.30	21.45	25.59	28.35	31.11
72	12.632	90	15.790	1.250						14.80	18.95	23.09	25.86	28.62
Length Factor*					0.80	0.80	0.90	0.90	0.95	0.95	1.00	1.00	1.00	1.05

*This length factor must be used to determine the proper belt width.

Center Distance is greater than eight times the small diameter and the large sprocket is not flanged. See Engineering Section I-10, Use of Flanged Sprockets, on page 134.



14mm Pitch PowerGrip® GT² Belts

Drive Selection Table

Sprocket Combinations				Speed Ratio	Center Distance, Inches										
DriveR		DriveN			96-14MGT P.L. 38.031 69 teeth	119-14MGT P.L. 46.850 85 teeth	140-14MGT P.L. 55.116 100 teeth	161-14MGT P.L. 63.386 115 teeth	177-14MGT P.L. 70.900 127 teeth	189-14MGT P.L. 74.409 135 teeth	210-14MGT P.L. 82.877 150 teeth	231-14MGT P.L. 90.945 165 teeth	245-14MGT P.L. 96.457 175 teeth	259-14MGT P.L. 101.968 185 teeth	
No. of Grooves	Pitch Diameter (Inches)	No. of Grooves	Pitch Diameter (Inches)												
38	6.667	48	8.421	1.263		11.54	15.69	19.83	23.13	25.34	29.48	33.61	36.37	39.13	
30	5.263	38	6.667	1.267	9.62	14.04	18.18	22.31	25.62	27.83	31.96	36.09	38.85	41.61	
44	7.720	56	9.825	1.273		9.59	13.74	17.88	21.19	23.40	27.54	31.67	34.43	37.19	
28	4.912	36	6.316	1.286	10.17	14.59	18.73	22.87	26.17	28.38	32.51	36.64	39.41	42.16	
56	9.825	72	12.632	1.286				13.99	17.31	19.52	23.66	27.80	30.56	33.32	
34	5.965	44	7.720	1.294	8.22	12.65	16.79	20.93	24.24	26.44	30.58	34.71	37.47	40.23	
40	7.018	52	9.123	1.300		10.70	14.85	18.99	22.30	24.51	28.64	32.78	35.54	38.29	
52	9.123	68	11.930	1.308				15.09	18.41	20.62	24.77	28.90	31.66	34.42	
29	5.088	38	6.667	1.310	9.75	14.17	18.31	22.45	25.76	27.96	32.10	36.23	38.99	41.75	
68	11.930	90	15.790	1.324				15.31	19.47	21.67	25.82	29.96	32.72	35.48	
30	5.263	40	7.018	1.333	9.33	13.75	17.89	22.03	25.34	27.55	31.68	35.81	38.57	41.33	
36	6.316	48	8.421	1.333		11.80	15.95	20.09	23.40	25.61	29.75	33.88	36.64	39.40	
48	8.421	64	11.229	1.333			12.05	16.20	19.52	21.73	25.87	30.00	32.77	35.52	
60	10.527	80	14.036	1.333				15.61	19.83	22.04	26.17	29.48	32.23	34.68	
28	4.912	38	6.667	1.357	9.88	14.30	18.45	22.58	25.89	28.10	32.23	36.37	39.13	41.88	
44	7.720	60	10.527	1.364			13.15	17.31	20.62	22.83	26.97	31.11	33.87	36.63	
38	6.667	52	9.123	1.368			10.95	15.11	19.25	22.57	24.77	28.91	33.05	35.81	
32	5.614	44	7.720	1.375	8.48	12.91	17.05	21.20	24.50	26.71	30.85	34.98	37.74	40.50	
29	5.088	40	7.018	1.379	9.46	13.88	18.03	22.17	25.47	27.68	31.82	35.95	38.71	41.47	
52	9.123	72	12.632	1.385				14.50	17.83	20.04	24.19	28.33	31.09	33.85	
40	7.018	56	9.825	1.400		10.10	14.26	18.41	21.73	23.94	28.08	32.21	34.97	37.73	
80	14.036	112	19.650	1.400								18.80	21.59	24.37	
64	11.229	90	15.790	1.406						15.82	19.99	24.14	26.91	29.68	
34	5.965	48	8.421	1.412		12.06	16.21	20.36	23.67	25.88	30.02	34.15	36.91	39.67	
48	8.421	68	11.930	1.417			11.44	15.61	18.94	21.15	25.30	29.43	32.20	34.96	
28	4.912	40	7.018	1.429	9.59	14.02	18.16	22.30	25.61	27.82	31.95	36.08	38.85	41.60	
56	9.825	80	14.036	1.429				12.78	16.12	18.34	22.50	26.65	29.41	32.18	
36	6.316	52	9.123	1.444		11.21	15.37	19.52	22.83	25.04	29.18	33.31	36.08	38.83	
44	7.720	64	11.229	1.455			12.55	16.72	20.04	22.25	26.40	30.54	33.30	36.06	
30	5.263	44	7.720	1.467	8.73	13.17	17.32	21.46	24.77	26.98	31.12	35.25	38.01	40.77	
38	6.667	56	9.825	1.474		10.35	14.52	18.68	21.99	24.20	28.34	32.48	35.24	38.00	
32	5.614	48	8.421	1.500	7.87	12.32	16.48	20.62	23.94	26.14	30.28	34.42	37.18	39.94	
40	7.018	60	10.527	1.500		9.48	13.67	17.83	21.15	23.36	27.50	31.64	34.41	37.16	
48	8.421	72	12.632	1.500				15.01	18.34	20.56	24.72	28.86	31.62	34.39	
60	10.527	90	15.790	1.500					14.08	16.32	20.50	24.66	27.43	30.20	
29	5.088	44	7.720	1.517	8.86	13.30	17.45	21.60	24.91	27.11	31.25	35.39	38.15	40.90	
34	5.965	52	9.123	1.529		11.47	15.63	19.78	23.10	25.31	29.45	33.58	36.35	39.10	
52	9.123	80	14.036	1.538				13.28	16.63	18.86	23.02	27.17	29.94	32.70	
44	7.720	68	11.930	1.545			11.94	16.12	19.45	21.67	25.82	29.96	32.73	35.49	
36	6.316	56	9.825	1.556		10.60	14.78	18.94	22.25	24.46	28.61	32.75	35.51	38.27	
72	12.632	112	19.650	1.556								19.80	22.60	25.39	
28	4.912	44	7.720	1.571	8.98	13.43	17.58	21.73	25.04	27.25	31.39	35.52	38.28	41.04	
38	6.667	60	10.527	1.579		9.73	13.92	18.09	21.41	23.62	27.77	31.91	34.67	37.43	
30	5.263	48	8.421	1.600	8.11	12.58	16.74	20.89	24.20	26.41	30.55	34.69	37.45	40.21	
40	7.018	64	11.229	1.600			13.06	17.24	20.56	22.78	26.93	31.07	33.83	36.59	
56	9.825	90	15.790	1.607					14.58	16.82	21.01	25.18	27.95	30.72	
32	5.614	52	9.123	1.625		11.72	15.89	20.04	23.36	25.57	29.71	33.85	36.61	39.37	
44	7.720	72	12.632	1.636			11.31	15.52	18.86	21.08	25.24	29.38	32.15	34.91	
34	5.965	56	9.825	1.647		10.85	15.03	19.20	22.52	24.73	28.87	33.01	35.78	38.54	
68	11.930	112	19.650	1.647								20.30	23.10	25.89	
29	5.088	48	8.421	1.655	8.24	12.71	16.87	21.02	24.33	26.54	30.68	34.82	37.58	40.34	
36	6.316	60	10.527	1.667		9.97	14.17	18.35	21.67	23.88	28.03	32.17	34.94	37.70	
48	8.421	80	14.036	1.667				13.77	17.13	19.36	23.53	27.69	30.46	33.23	
38	6.667	64	11.229	1.684			13.31	17.49	20.82	23.04	27.19	31.33	34.10	36.86	
40	7.018	68	11.930	1.700			12.43	16.63	19.97	22.19	26.34	30.49	33.26	36.02	
28	4.912	48	8.421	1.714	8.36	12.83	17.00	21.15	24.47	26.68	30.82	34.95	37.72	40.48	
52	9.123	90	15.790	1.731					15.06	17.32	21.51	25.69	28.47	31.24	
30	5.263	52	9.123	1.733		11.97	16.15	20.30	23.62	25.83	29.98	34.12	36.88	39.64	
32	5.614	56	9.825	1.750		11.10	15.29	19.46	22.78	24.99	29.14	33.28	36.04	38.80	
64	11.229	112	19.650	1.750							16.55	20.79	23.60	26.40	
34	5.965	60	10.527	1.765		10.22	14.43	18.60	21.93	24.14	28.30	32.44	35.20	37.96	
36	6.316	64	11.229	1.778			13.56	17.74	21.08	23.30	27.45	31.59	34.36	37.12	
38	6.667	68	11.930	1.789			12.68	16.88	20.22	22.44	26.60	30.75	33.52	36.28	
29	5.088	52	9.123	1.793		12.10	16.27	20.43	23.75	25.97	30.11	34.25	37.01	39.77	
Length Factor*					0.80	0.80	0.90	0.90	0.95	0.95	1.00	1.00	1.00	1.00	1.05

*This length factor must be used to determine the proper belt width.

Center Distance is greater than eight times the small diameter and the large sprocket is not flanged. See Engineering Section I-10, Use of Flanged Sprockets, on page 134.



14mm Pitch PowerGrip® GT®2 Belts

Drive Selection Table

Center Distance, Inches													Speed Ratio	Sprocket Combinations	
														DriveR	DriveN
2800-14MGT P.L. 110.236 200 teeth	3160-14MGT P.L. 124.016 225 teeth	3360-14MGT P.L. 132.283 240 teeth	3500-14MGT P.L. 137.795 250 teeth	3850-14MGT P.L. 151.575 275 teeth	4326-14MGT P.L. 170.315 309 teeth	4578-14MGT P.L. 180.236 327 teeth	4966-14MGT P.L. 195.118 354 teeth	5300-14MGT P.L. 209.449 380 teeth	5740-14MGT P.L. 225.984 410 teeth	6160-14MGT P.L. 242.520 440 teeth	6660-14MGT P.L. 270.079 490 teeth	No. of grooves		No. of grooves	
43.26	50.15	54.28	57.04	63.93	73.30	78.26	85.71	92.87	101.14	109.41	123.19	1.263	38	48	
45.74	52.64	56.77	59.53	66.41	75.78	80.75	88.19	95.35	103.62	111.89	125.67	1.267	30	38	
41.33	48.22	52.35	55.11	62.00	71.37	76.33	83.77	90.94	99.20	107.48	121.26	1.273	44	56	
46.30	53.19	57.32	60.08	66.96	76.33	81.30	88.74	95.90	104.17	112.44	126.22	1.286	28	36	
37.46	44.35	48.48	51.24	58.13	67.50	72.47	79.91	87.08	95.34	103.61	117.39	1.286	56	72	
44.36	51.25	55.38	58.15	65.03	74.40	79.37	86.81	93.97	102.24	110.51	124.29	1.294	34	44	
42.43	49.32	53.45	56.21	63.10	72.47	77.44	84.88	92.04	100.31	108.58	122.36	1.300	40	52	
38.56	45.45	49.59	52.35	59.23	68.61	73.57	81.01	88.18	96.44	104.72	118.50	1.308	52	68	
45.88	52.77	56.90	59.66	66.55	75.92	80.88	88.32	95.49	103.75	112.02	125.81	1.310	29	38	
33.29	40.19	44.33	47.09	53.98	63.35	68.32	75.76	82.93	91.20	99.47	113.25	1.324	68	90	
45.47	52.36	56.49	59.25	66.13	75.50	80.47	87.91	95.08	103.34	111.61	125.39	1.333	30	40	
43.53	50.42	54.56	57.32	64.20	73.57	78.54	85.98	93.14	101.41	109.68	123.46	1.333	36	48	
39.66	46.56	50.69	53.45	60.34	69.71	74.67	82.11	89.28	97.55	105.82	119.60	1.333	48	64	
35.79	42.68	46.82	49.58	56.47	65.84	70.81	78.25	85.42	93.68	101.95	115.73	1.333	60	80	
46.02	52.91	57.04	59.80	66.69	76.06	81.02	88.46	95.63	103.89	112.16	125.94	1.357	28	38	
40.76	47.66	51.79	54.55	61.44	70.81	75.78	83.22	90.38	98.65	106.92	120.70	1.364	44	60	
42.70	49.59	53.72	56.49	63.37	72.74	77.71	85.15	92.32	100.58	108.85	122.63	1.368	38	52	
44.64	51.53	55.66	58.42	65.30	74.68	79.64	87.08	94.25	102.51	110.78	124.56	1.375	32	44	
45.60	52.49	56.62	59.38	66.27	75.64	80.61	88.05	95.21	103.48	111.75	125.53	1.379	29	40	
37.99	44.89	49.02	51.78	58.67	68.05	73.01	80.45	87.62	95.89	104.16	117.94	1.385	52	72	
41.87	48.76	52.89	55.65	62.54	71.91	76.88	84.32	91.49	99.75	108.02	121.80	1.400	40	56	
28.52	35.44	39.58	42.35	49.25	58.63	63.60	71.05	78.22	86.49	94.76	108.55	1.400	80	112	
33.82	40.73	44.86	47.62	54.52	63.89	68.86	76.31	83.47	91.74	100.01	113.80	1.406	64	90	
43.80	50.70	54.83	57.59	64.47	73.85	78.81	86.25	93.42	101.68	109.95	123.74	1.412	34	48	
39.10	45.99	50.13	52.89	59.78	69.15	74.12	81.56	88.72	96.99	105.26	119.04	1.417	48	68	
45.74	52.63	56.76	59.52	66.41	75.78	80.74	88.18	95.35	103.61	111.89	125.67	1.429	28	40	
36.32	43.22	47.35	50.12	57.01	66.38	71.35	78.79	85.96	94.23	102.50	116.28	1.429	56	80	
42.97	49.86	54.00	56.76	63.64	73.02	77.98	85.42	92.59	100.85	109.13	122.91	1.444	36	52	
40.20	47.09	51.23	53.99	60.88	70.25	75.22	82.66	89.83	98.09	106.36	120.14	1.455	44	64	
44.91	51.80	55.93	58.69	65.58	74.95	79.91	87.35	94.52	102.79	111.06	124.84	1.467	30	44	
42.14	49.03	53.16	55.92	62.81	72.18	77.15	84.59	91.76	100.02	108.30	122.08	1.474	38	56	
44.07	50.97	55.10	57.86	64.75	74.12	79.08	86.53	93.69	101.96	110.23	124.01	1.500	32	48	
41.30	48.20	52.33	55.09	61.98	71.35	76.32	83.76	90.93	99.19	107.47	121.25	1.500	40	60	
38.53	45.43	49.56	52.32	59.21	68.59	73.55	81.00	88.16	96.43	104.70	118.49	1.500	48	72	
34.35	41.26	45.39	48.16	55.05	64.43	69.40	76.85	84.01	92.28	100.56	114.34	1.500	60	90	
45.04	51.93	56.07	58.83	65.71	75.08	80.05	87.49	94.66	102.92	111.19	124.97	1.517	29	44	
43.24	50.14	54.27	57.03	63.92	73.29	78.25	85.70	92.86	101.13	109.40	123.18	1.529	34	52	
36.85	43.75	47.89	50.65	57.54	66.92	71.89	79.33	86.50	94.77	103.04	116.83	1.538	52	80	
39.63	46.53	50.66	53.43	60.32	69.69	74.66	82.10	89.27	97.53	105.81	119.59	1.545	44	68	
42.41	49.30	53.43	56.20	63.08	72.46	77.42	84.86	92.03	100.30	108.57	122.35	1.556	36	56	
29.56	36.49	40.63	43.40	50.31	59.70	64.67	72.12	79.29	87.57	95.84	109.63	1.556	72	112	
45.18	52.07	56.20	58.96	65.85	75.22	80.19	87.63	94.79	103.06	111.33	125.11	1.571	28	44	
41.57	48.47	52.60	55.36	62.25	71.62	76.59	84.03	91.20	99.47	107.74	121.52	1.579	38	60	
44.34	51.24	55.37	58.13	65.02	74.39	79.36	86.80	93.96	102.23	110.50	124.28	1.600	30	48	
40.73	47.63	51.77	54.53	61.42	70.79	75.76	83.20	90.37	98.64	106.91	120.69	1.600	40	64	
34.87	41.79	45.93	48.69	55.59	64.97	69.94	77.38	84.55	92.82	101.10	114.88	1.607	56	90	
43.51	50.41	54.54	57.30	64.19	73.56	78.53	85.97	93.13	101.40	109.67	123.45	1.625	32	52	
39.06	45.96	50.10	52.86	59.75	69.13	74.09	81.54	88.71	96.97	105.25	119.03	1.636	44	72	
42.67	49.57	53.70	56.47	63.35	72.73	77.69	85.14	92.30	100.57	108.84	122.62	1.647	34	56	
30.07	37.01	41.16	43.93	50.84	60.23	65.20	72.65	79.83	88.10	96.38	110.17	1.647	68	112	
44.48	51.37	55.51	58.27	65.15	74.53	79.49	86.93	94.10	102.37	110.64	124.42	1.655	29	48	
41.84	48.74	52.87	55.63	62.52	71.90	76.86	84.31	91.47	99.74	108.01	121.79	1.667	36	60	
37.38	44.28	48.42	51.19	58.08	67.46	72.43	79.87	87.04	95.31	103.58	117.37	1.667	48	80	
41.00	47.90	52.03	54.80	61.69	71.06	76.03	83.47	90.64	98.91	107.18	120.96	1.684	38	64	
40.16	47.06	51.20	53.96	60.85	70.23	75.20	82.64	89.81	98.08	106.35	120.13	1.700	40	68	
44.61	51.51	55.64	58.40	65.29	74.66	79.63	87.07	94.24	102.50	110.77	124.56	1.714	28	48	
35.40	42.31	46.45	49.22	56.12	65.50	70.47	77.92	85.09	93.36	101.64	115.43	1.731	52	90	
43.78	50.67	54.81	57.57	64.46	73.83	78.80	86.24	93.41	101.67	109.94	123.73	1.733	30	50	
42.94	49.84	53.97	56.74	63.62	73.00	77.97	85.41	92.58	100.84	109.11	122.90	1.750	32	56	
30.58	37.52	41.67	44.45	51.36	60.76	65.73	73.19	80.36	88.64	96.92	110.71	1.750	64	112	
42.11	49.00	53.14	55.90	62.79	72.17	77.13	84.58	91.74	100.01	108.28	122.07	1.765	34	60	
41.27	48.17	52.30	55.07	61.96	71.33	76.30	83.74	90.91	99.18	107.45	121.24	1.778	36	64	
40.43	47.33	51.47	54.23	61.12	70.50	75.47	82.91	90.08	98.35	106.62	120.41	1.789	38	68	
43.91	50.81	54.94	57.70	64.59	73.97	78.93	86.38	93.54	101.81	110.08	123.86	1.793	29	52	
1.05	1.05	1.10	1.10	1.10	1.10	1.10	1.10	1.10	1.10	1.10	1.10	1.10			

*This length factor must be used to determine the proper belt width.

Center Distance is greater than eight times the small diameter and the large sprocket is not flanged. See Engineering Section I-10, Use of Flanged Sprockets, on page 134.



14mm Pitch PowerGrip® GT² Belts

Drive Selection Table

Sprocket Combinations				Speed Ratio	Center Distance, Inches										
DriveR		DriveN			96-14MGT P.L. 38.031 69 teeth	119-14MGT P.L. 46.850 85 teeth	140-14MGT P.L. 55.116 100 teeth	161-14MGT P.L. 63.386 115 teeth	177-14MGT P.L. 70.900 127 teeth	189-14MGT P.L. 74.409 135 teeth	210-14MGT P.L. 82.877 150 teeth	231-14MGT P.L. 90.945 165 teeth	245-14MGT P.L. 96.457 175 teeth	259-14MGT P.L. 101.968 185 teeth	
No. of Grooves	Pitch Diameter (Inches)	No. of Grooves	Pitch Diameter (Inches)												
40	7.018	72	12.632	1.800			11.79	16.02	19.36	21.59	25.75	29.91	32.68	35.44	
80	14.036	144	25.264	1.800											
44	7.720	80	14.036	1.818				14.26	17.63	19.87	24.05	28.21	30.98	33.75	
28	4.912	52	9.123	1.857	7.70	12.22	16.40	20.56	23.88	26.10	30.24	34.38	37.15	39.91	
30	5.263	56	9.825	1.867			11.34	15.54	19.71	23.04	25.25	29.40	33.54	36.31	
60	10.527	112	19.650	1.867							17.02	21.28	24.10	26.90	
32	5.614	60	10.527	1.875			10.46	14.68	18.86	22.19	24.40	28.56	32.70	35.47	
48	8.421	90	15.790	1.875							17.81	22.02	26.20	28.98	
34	5.965	64	11.229	1.882			9.56	13.80	18.00	21.33	23.55	27.71	31.86	34.63	
36	6.316	68	11.930	1.889				12.92	17.13	20.48	22.70	26.86	31.01	33.78	
38	6.667	72	12.632	1.895				12.03	16.26	19.62	21.84	26.01	30.17	32.94	
29	5.088	56	9.825	1.931			11.47	15.67	19.84	23.17	25.38	29.53	33.67	36.44	
28	4.912	56	9.825	2.000			11.59	15.79	19.97	23.30	25.51	29.66	33.81	36.57	
30	5.263	60	10.527	2.000			10.70	14.93	19.11	22.44	24.66	28.82	32.96	35.73	
32	5.614	64	11.229	2.000			9.79	14.05	18.25	21.59	23.81	27.97	32.12	34.89	
34	5.965	68	11.930	2.000				13.17	17.38	20.73	22.96	27.12	31.27	34.04	
36	6.316	72	12.632	2.000				12.27	16.51	19.87	22.10	26.27	30.42	33.20	
40	7.018	80	14.036	2.000				14.74	18.12	20.37	24.55	28.72	31.50	34.27	
56	9.825	112	19.650	2.000							17.50	21.76	24.59	27.39	
72	12.632	144	25.264	2.000										20.23	
44	7.720	90	15.790	2.045					12.58	16.02	18.29	22.51	26.70	29.49	
29	5.088	60	10.527	2.069			10.82	15.05	19.24	22.57	24.79	28.95	33.09	35.86	
80	14.036	168	29.475	2.100											
38	6.667	80	14.036	2.105					14.98	18.37	20.61	24.81	28.98	31.76	
34	5.965	72	12.632	2.118				12.51	16.76	20.12	22.35	26.52	30.68	33.46	
68	11.930	144	25.264	2.118										20.69	
32	5.614	68	11.930	2.125				13.41	17.63	20.98	23.21	27.38	31.53	34.31	
30	5.263	64	11.229	2.133			10.03	14.29	18.50	21.84	24.07	28.23	32.38	35.15	
28	4.912	60	10.527	2.143			10.94	15.17	19.37	22.70	24.92	29.08	33.23	35.99	
52	9.123	112	19.650	2.154								17.97	22.25	25.08	
29	5.088	64	11.229	2.207			10.14	14.42	18.63	21.97	24.19	28.36	32.51	35.28	
36	6.316	80	14.036	2.222				10.88	15.22	18.61	20.86	25.06	29.23	32.01	
32	5.614	72	12.632	2.250				12.74	17.00	20.37	22.60	26.78	30.94	33.72	
40	7.018	90	15.790	2.250					13.04	16.50	18.78	23.01	27.20	30.00	
64	11.229	144	25.264	2.250										21.15	
30	5.263	68	11.930	2.267			9.32	13.65	17.88	21.23	23.46	27.64	31.79	34.57	
28	4.912	64	11.229	2.286			10.26	14.54	18.75	22.10	24.32	28.49	32.64	35.41	
48	8.421	112	19.650	2.333								18.43	22.73	25.56	
72	12.632	168	29.475	2.333											
29	5.088	68	11.930	2.345			9.43	13.77	18.00	21.36	23.59	27.76	31.92	34.70	
34	5.965	80	14.036	2.353				11.11	15.46	18.86	21.11	25.31	29.48	32.27	
38	6.667	90	15.790	2.368					13.27	16.74	19.02	23.25	27.45	30.25	
30	5.263	72	12.632	2.400				12.98	17.25	20.62	22.85	27.03	31.20	33.98	
60	10.527	144	25.264	2.400										18.64	
80	14.036	192	33.686	2.400											
28	4.912	68	11.930	2.429			9.54	13.89	18.13	21.49	23.72	27.89	32.05	34.83	
68	11.930	168	29.475	2.471											
29	5.088	72	12.632	2.483				13.10	17.37	20.74	22.98	27.16	31.33	34.10	
32	5.614	80	14.036	2.500				11.34	15.69	19.10	21.36	25.56	29.74	32.52	
36	6.316	90	15.790	2.500					13.49	16.97	19.26	23.50	27.70	30.50	
44	7.720	112	19.650	2.545							14.46	18.89	23.20	26.05	
28	4.912	72	12.632	2.571				13.21	17.49	20.86	23.10	27.29	31.45	34.23	
56	9.825	144	25.264	2.571										19.09	
64	11.229	168	29.475	2.625											
34	5.965	90	15.790	2.647					13.72	17.21	19.50	23.74	27.95	30.75	
30	5.263	80	14.036	2.667				11.56	15.93	19.34	21.60	25.81	29.99	32.78	
72	12.632	192	33.686	2.667											
29	5.088	80	14.036	2.759			11.67	16.05	19.46	21.72	25.93	30.12	32.91	35.68	
52	9.123	144	25.264	2.769										19.53	
40	7.018	112	19.650	2.800							14.90	19.36	23.68	26.53	
60	10.527	168	29.475	2.800											
32	5.614	90	15.790	2.813					13.95	17.44	19.73	23.99	28.20	31.00	
68	11.930	192	33.686	2.824											
28	4.912	80	14.036	2.857			11.78	16.17	19.58	21.85	26.06	30.24	33.03	35.81	
Length Factor*					0.80	0.80	0.90	0.90	0.95	0.95	1.00	1.00	1.00	1.00	1.05

*This length factor must be used to determine the proper belt width.

Center Distance is greater than eight times the small diameter and the large sprocket is not flanged. See Engineering Section I-10, Use of Flanged Sprockets, on page 134.



14mm Pitch PowerGrip® GT®2 Belts

Drive Selection Table

Center Distance, Inches													Sprocket Combinations	
2800-14MGT P.L. 110.236 200 teeth	3160-14MGT P.L. 124.016 225 teeth	3360-14MGT P.L. 132.283 240 teeth	3500-14MGT P.L. 137.795 250 teeth	3850-14MGT P.L. 151.575 275 teeth	4326-14MGT P.L. 170.315 309 teeth	4578-14MGT P.L. 180.236 327 teeth	4966-14MGT P.L. 195.118 354 teeth	5300-14MGT P.L. 209.449 380 teeth	5740-14MGT P.L. 225.984 410 teeth	6160-14MGT P.L. 242.520 440 teeth	6660-14MGT P.L. 270.079 490 teeth	Speed Ratio	Drive	
													DriveR	DriveN
													No. of grooves	No. of grooves
39.59	46.49	50.63	53.39	60.29	69.67	74.63	82.08	89.25	97.52	105.79	119.57	1.800	40	72
23.58	30.63	34.82	37.61	44.56	54.00	58.99	66.46	73.64	81.93	90.22	104.02	1.800	80	144
37.90	44.81	48.95	51.72	58.61	67.99	72.96	80.41	87.58	95.85	104.12	117.91	1.818	44	80
44.05	50.94	55.08	57.84	64.73	74.10	79.07	86.51	93.68	101.95	110.22	124.00	1.857	28	52
43.21	50.11	54.24	57.00	63.89	73.27	78.24	85.68	92.85	101.11	109.39	123.17	1.867	30	56
31.08	38.04	42.19	44.97	51.88	61.28	66.26	73.72	80.90	89.17	97.45	111.25	1.867	60	112
42.37	49.27	53.41	56.17	63.06	72.44	77.40	84.85	92.02	100.28	108.56	122.34	1.875	32	60
35.92	42.84	46.98	49.75	56.65	66.04	71.01	78.46	85.63	93.90	102.18	115.97	1.875	48	90
41.53	48.43	52.57	55.33	62.23	71.60	76.57	84.01	91.18	99.45	107.72	121.51	1.882	34	64
40.69	47.60	51.73	54.50	61.39	70.77	75.74	83.18	90.35	98.62	106.89	120.68	1.889	36	68
39.85	46.76	50.90	53.66	60.55	69.93	74.90	82.35	89.52	97.79	106.06	119.85	1.895	38	72
43.34	50.24	54.38	57.14	64.03	73.40	78.37	85.81	92.98	101.25	109.52	123.30	1.931	29	56
43.48	50.38	54.51	57.27	64.16	73.54	78.51	85.95	93.12	101.39	109.66	123.44	2.000	28	56
42.64	49.54	53.67	56.44	63.33	72.71	77.67	85.12	92.29	100.55	108.83	122.61	2.000	30	60
41.80	48.70	52.84	55.60	62.49	71.87	76.84	84.28	91.45	99.72	108.00	121.78	2.000	32	64
40.96	47.86	52.00	54.76	61.66	71.04	76.01	83.45	90.62	98.89	107.16	120.95	2.000	34	68
40.11	47.02	51.16	53.93	60.82	70.20	75.17	82.62	89.79	98.06	106.33	120.12	2.000	36	72
38.42	45.34	49.48	52.25	59.15	68.53	73.50	80.95	88.12	96.39	104.67	118.45	2.000	40	80
31.59	38.55	42.71	45.48	52.40	61.81	66.79	74.25	81.43	89.71	97.99	111.78	2.000	56	112
24.54	31.61	35.82	38.62	45.58	55.03	60.02	67.50	74.69	82.99	91.28	105.09	2.000	72	144
36.43	43.36	47.50	50.27	57.18	66.57	71.54	78.99	86.17	94.44	102.72	116.51	2.045	44	90
42.77	49.67	53.81	56.57	63.46	72.84	77.81	85.25	92.42	100.69	108.96	122.75	2.069	29	60
	26.71	31.00	33.84	40.88	50.39	55.41	62.91	70.13	78.44	86.74	100.57	2.100	80	168
38.68	45.60	49.74	52.51	59.41	68.80	73.77	81.22	88.39	96.66	104.94	118.72	2.105	38	80
40.38	47.29	51.43	54.19	61.09	70.47	75.44	82.89	90.06	98.33	106.60	120.39	2.118	34	72
25.01	32.10	36.31	39.12	46.09	55.54	60.54	68.02	75.22	83.51	91.81	105.62	2.118	68	144
41.22	48.13	52.27	55.03	61.93	71.31	76.28	83.72	90.89	99.16	107.43	121.22	2.125	32	68
42.06	48.97	53.10	55.87	62.76	72.14	77.11	84.55	91.72	99.99	108.27	122.05	2.133	30	64
42.90	49.81	53.94	56.70	63.60	72.98	77.94	85.39	92.56	100.83	109.10	122.88	2.143	28	60
32.09	39.06	43.22	46.00	52.92	62.33	67.32	74.78	81.96	90.24	98.52	112.32	2.154	52	112
42.19	49.10	53.24	56.00	62.89	72.27	77.24	84.69	91.86	100.13	108.40	122.19	2.207	29	64
38.94	45.86	50.01	52.77	59.68	69.06	74.03	81.48	88.66	96.93	105.20	118.99	2.222	36	80
40.64	47.55	51.69	54.46	61.35	70.74	75.71	83.16	90.33	98.60	106.87	120.66	2.250	32	72
36.95	43.88	48.03	50.80	57.70	67.10	72.07	79.53	86.70	94.98	103.25	117.04	2.250	40	90
25.49	32.59	36.81	39.62	46.59	56.05	61.05	68.54	75.74	84.04	92.33	106.15	2.250	64	144
41.48	48.39	52.53	55.30	62.19	71.57	76.54	83.99	91.16	99.43	107.71	121.49	2.267	30	68
42.32	49.23	53.37	56.13	63.03	72.41	77.38	84.82	91.99	100.26	108.54	122.32	2.286	28	64
32.59	39.56	43.73	46.51	53.44	62.86	67.84	75.30	82.49	90.77	99.05	112.85	2.333	48	112
	27.65	31.95	34.81	41.86	51.39	56.42	63.93	71.16	79.47	87.78	101.62	2.333	72	168
41.61	48.52	52.66	55.43	62.33	71.71	76.68	84.12	91.29	99.57	107.84	121.63	2.345	29	68
39.20	46.12	50.27	53.04	59.94	69.33	74.30	81.75	88.92	97.20	105.47	119.26	2.353	34	80
37.20	44.14	48.29	51.06	57.97	67.36	72.34	79.79	86.97	95.24	103.52	117.31	2.368	38	90
40.90	47.81	51.95	54.72	61.62	71.00	75.98	83.42	90.60	98.87	107.14	120.93	2.400	30	72
25.96	33.08	37.30	40.11	47.10	56.56	61.57	69.06	76.26	84.56	92.86	106.68	2.400	60	144
		26.84	29.78	36.99	46.64	51.70	59.26	66.52	74.86	83.20	97.06	2.400	80	192
41.74	48.66	52.80	55.56	62.46	71.84	76.81	84.26	91.43	99.70	107.98	121.76	2.429	28	68
	28.11	32.43	35.28	42.35	51.89	56.92	64.44	71.67	79.99	88.30	102.14	2.471	68	168
41.03	47.94	52.09	54.85	61.75	71.14	76.11	83.56	90.73	99.00	107.28	121.06	2.483	29	72
39.46	46.39	50.53	53.30	60.20	69.59	74.57	82.02	89.19	97.47	105.74	119.53	2.500	32	80
37.46	44.40	48.55	51.32	58.23	67.63	72.60	80.06	87.23	95.51	103.79	117.58	2.500	36	90
33.08	40.07	44.24	47.02	53.96	63.38	68.36	75.83	83.01	91.30	99.58	113.39	2.545	44	112
41.16	48.08	52.22	54.99	61.89	71.27	76.24	83.69	90.86	99.14	107.41	121.20	2.571	28	72
26.43	33.56	37.79	40.61	47.60	57.07	62.08	69.57	76.78	85.08	93.38	107.20	2.571	56	144
21.15	28.57	32.90	35.76	42.84	52.39	57.42	64.95	72.18	80.50	88.82	102.67	2.625	64	168
37.71	44.65	48.81	51.58	58.49	67.89	72.87	80.32	87.50	95.78	104.06	117.85	2.647	34	90
39.72	46.65	50.79	53.56	60.47	69.86	74.83	82.29	89.46	97.73	106.01	119.80	2.667	30	80
		27.74	30.70	37.94	47.61	52.69	60.26	67.52	75.88	84.22	98.10	2.667	72	192
39.85	46.78	50.92	53.69	60.60	69.99	74.97	82.42	89.59	97.87	106.15	119.94	2.759	29	80
26.89	34.04	38.28	41.10	48.10	57.58	62.59	70.09	77.30	85.60	93.91	107.73	2.769	52	144
33.58	40.57	44.75	47.53	54.47	63.90	68.89	76.35	83.54	91.83	100.12	113.92	2.800	40	112
21.59	29.03	33.37	36.24	43.33	52.89	57.93	65.46	72.69	81.02	89.34	103.19	2.800	60	168
37.97	44.91	49.07	51.84	58.75	68.15	73.13	80.59	87.77	96.04	104.33	118.12	2.813	32	90
	23.63	28.19	31.15	38.41	48.09	53.18	60.76	68.03	76.39	84.73	98.61	2.824	68	192
39.98	46.91	51.05	53.82	60.73	70.12	75.10	82.55	89.73	98.00	106.28	120.07	2.857	28	80
1.05	1.05	1.10	1.10	1.10	1.10	1.10	1.10	1.10	1.10	1.10	1.10			

*This length factor must be used to determine the proper belt width.

Center Distance is greater than eight times the small diameter and the large sprocket is not flanged. See Engineering Section I-10, Use of Flanged Sprockets, on page 134.



14mm Pitch PowerGrip® GT®2 Belts

Drive Selection Table

Sprocket Combinations				Speed Ratio	Center Distance, Inches									
DriveR		DriveN			966-14MGT P.L. 38.031 69 teeth	1190-14MGT P.L. 46.850 85 teeth	1400-14MGT P.L. 55.116 100 teeth	1610-14MGT P.L. 63.386 115 teeth	1776-14MGT P.L. 70.900 127 teeth	1890-14MGT P.L. 74.409 135 teeth	2100-14MGT P.L. 82.677 150 teeth	2310-14MGT P.L. 90.945 165 teeth	2450-14MGT P.L. 96.457 175 teeth	2590-14MGT P.L. 101.968 185 teeth
No. of Grooves	Pitch Diameter (Inches)	No. of Grooves	Pitch Diameter (Inches)											
38	6.667	112	19.650	2.947						15.12	19.58	23.91	26.77	29.60
30	5.263	90	15.790	3.000			14.17	17.68	19.97	24.23	28.45	31.25	34.04	34.04
48	8.421	144	25.264	3.000								19.97	22.97	22.97
56	9.825	168	29.475	3.000										
64	11.229	192	33.686	3.000										
29	5.088	90	15.790	3.103			14.28	17.79	20.09	24.35	28.57	31.38	34.17	34.17
36	6.316	112	19.650	3.111					15.34	19.81	24.15	27.01	29.84	29.84
60	10.527	192	33.686	3.200										
28	4.912	90	15.790	3.214			14.40	17.91	20.21	24.47	28.69	31.50	34.29	34.29
52	9.123	168	29.475	3.231										
44	7.720	144	25.264	3.273							17.29	20.41	23.42	23.42
34	5.965	112	19.650	3.294					15.56	20.04	24.39	27.25	30.09	30.09
56	9.825	192	33.686	3.429										
32	5.614	112	19.650	3.500				13.25	15.77	20.27	24.62	27.49	30.33	30.33
48	8.421	168	29.475	3.500										
40	7.018	144	25.264	3.600							17.71	20.85	23.86	23.86
52	9.123	192	33.686	3.692										
30	5.263	112	19.650	3.733					13.46	15.99	20.50	24.85	27.72	30.57
38	6.667	144	25.264	3.789							17.92	21.06	24.09	24.09
44	7.720	168	29.475	3.818										
29	5.088	112	19.650	3.862					13.57	16.10	20.61	24.97	27.84	30.69
28	4.912	112	19.650	4.000					13.67	16.21	20.72	25.09	27.96	30.81
36	6.316	144	25.264	4.000							18.13	21.28	24.31	24.31
48	8.421	192	33.686	4.000										
40	7.018	168	29.475	4.200										18.87
34	5.965	144	25.264	4.235							18.34	21.50	24.53	24.53
44	7.720	192	33.686	4.364										
38	6.667	168	29.475	4.421										19.08
32	5.614	144	25.264	4.500								18.55	21.72	24.76
36	6.316	168	29.475	4.667										19.28
30	5.263	144	25.264	4.800							18.76	21.93	24.98	24.98
40	7.018	192	33.686	4.800										
34	5.965	168	29.475	4.941										19.48
29	5.088	144	25.264	4.966							18.86	22.04	25.09	25.09
38	6.667	192	33.686	5.053										
28	4.912	144	25.264	5.143							18.97	22.15	25.20	25.20
32	5.614	168	29.475	5.250										19.69
36	6.316	192	33.686	5.333										
30	5.263	168	29.475	5.600										19.89
34	5.965	192	33.686	5.647										
29	5.088	168	29.475	5.793										19.99
28	4.912	168	29.475	6.000										20.09
32	5.614	192	33.686	6.000										
30	5.263	192	33.686	6.400										
29	5.088	192	33.686	6.621										
28	4.912	192	33.686	6.857										
Length Factor*					0.80	0.80	0.90	0.90	0.95	0.95	1.00	1.00	1.00	1.05

*This length factor must be used to determine the proper belt width.

Center Distance is greater than eight times the small diameter and the large sprocket is not flanged. See Engineering Section I-10, Use of Flanged Sprockets, on page 134.



Center Distance, Inches												Sprocket Combinations		
2800-14MGT P.L. 110.236 200 teeth	3160-14MGT P.L. 124.016 225 teeth	3360-14MGT P.L. 132.283 240 teeth	3500-14MGT P.L. 137.795 250 teeth	3850-14MGT P.L. 151.575 275 teeth	4326-14MGT P.L. 170.315 309 teeth	4578-14MGT P.L. 180.236 327 teeth	4956-14MGT P.L. 195.118 354 teeth	5320-14MGT P.L. 209.449 380 teeth	5740-14MGT P.L. 225.984 410 teeth	6160-14MGT P.L. 242.520 440 teeth	6660-14MGT P.L. 270.079 490 teeth	Speed Ratio	DriveR	DriveN
													No. of grooves	No. of grooves
33.83	40.82	45.00	47.79	54.73	64.16	69.15	76.62	83.80	92.09	100.38	114.19	2.947	38	112
38.22	45.17	49.32	52.10	59.02	68.42	73.40	80.85	88.03	96.31	104.59	118.39	3.000	30	90
27.36	34.52	38.77	41.59	48.60	58.09	63.10	70.60	77.81	86.12	94.43	108.26	3.000	48	144
22.02	29.49	33.84	36.71	43.81	53.38	58.43	65.96	73.20	81.53	89.86	103.71	3.000	56	168
	24.06	28.63	31.61	38.88	48.58	53.66	61.25	68.53	76.89	85.24	99.13	3.000	64	192
38.35	45.30	49.45	52.23	59.15	68.55	73.53	80.99	88.17	96.44	104.73	118.52	3.103	29	90
34.07	41.07	45.25	48.04	54.99	64.42	69.41	76.88	84.07	92.36	100.65	114.45	3.111	36	112
	24.49	29.08	32.06	39.34	49.06	54.15	61.75	69.03	77.40	85.75	99.64	3.200	60	192
38.48	45.42	49.58	52.36	59.28	68.68	73.66	81.12	88.30	96.58	104.86	118.66	3.214	28	90
22.46	29.95	34.30	37.18	44.30	53.88	58.92	66.46	73.71	82.04	90.37	104.23	3.231	52	168
27.82	35.00	39.25	42.08	49.09	58.59	63.61	71.11	78.33	86.64	94.95	108.78	3.273	44	144
34.32	41.32	45.51	48.30	55.24	64.67	69.67	77.14	84.33	92.62	100.91	114.72	3.294	34	112
	24.92	29.52	32.51	39.81	49.54	54.64	62.24	69.53	77.90	86.26	100.16	3.429	56	192
34.56	41.57	45.76	48.55	55.50	64.93	69.93	77.40	84.59	92.88	101.17	114.98	3.500	32	112
22.89	30.41	34.77	37.66	44.78	54.37	59.42	66.97	74.21	82.55	90.89	104.75	3.500	48	168
28.28	35.48	39.73	42.56	49.59	59.10	64.12	71.62	78.84	87.16	95.47	109.30	3.600	40	144
	25.35	29.96	32.96	40.28	50.02	55.12	62.73	70.02	78.40	86.77	100.67	3.692	52	192
34.81	41.82	46.01	48.80	55.75	65.19	70.18	77.66	84.85	93.15	101.44	115.25	3.733	30	112
28.51	35.71	39.98	42.81	49.84	59.35	64.37	71.88	79.10	87.42	95.73	109.57	3.789	38	144
23.32	30.86	35.23	38.12	45.26	54.86	59.92	67.47	74.72	83.06	91.40	105.26	3.818	44	168
34.93	41.95	46.14	48.93	55.88	65.32	70.31	77.79	84.98	93.28	101.57	115.38	3.862	29	112
35.05	42.07	46.26	49.05	56.01	65.45	70.44	77.92	85.11	93.41	101.70	115.51	4.000	28	112
28.74	35.95	40.22	43.05	50.08	59.60	64.62	72.13	79.36	87.67	95.99	109.83	4.000	36	144
	25.78	30.41	33.41	40.74	50.50	55.61	63.22	70.52	78.91	87.27	101.18	4.000	48	192
23.75	31.31	35.70	38.59	45.74	55.35	60.41	67.97	75.22	83.57	91.91	105.78	4.200	40	168
28.97	36.19	40.46	43.29	50.33	59.85	64.87	72.39	79.61	87.93	96.25	110.09	4.235	34	144
	26.20	30.84	33.86	41.20	50.97	56.09	63.71	71.01	79.41	87.78	101.69	4.364	44	192
23.97	31.54	35.93	38.83	45.98	55.60	60.66	68.22	75.48	83.83	92.17	106.04	4.421	38	168
29.20	36.43	40.70	43.54	50.58	60.10	65.13	72.64	79.87	88.19	96.51	110.35	4.500	32	144
24.18	31.76	36.16	39.06	46.22	55.84	60.91	68.47	75.73	84.08	92.42	106.30	4.667	36	168
29.43	36.66	40.94	43.78	50.82	60.35	65.38	72.90	80.12	88.45	96.77	110.61	4.800	30	144
	26.63	31.28	34.31	41.66	51.45	56.57	64.20	71.51	79.91	88.28	102.20	4.800	40	192
24.39	31.99	36.39	39.29	46.46	56.08	61.15	68.72	75.98	84.33	92.68	106.56	4.941	34	168
29.54	36.78	41.06	43.90	50.94	60.47	65.50	73.02	80.25	88.58	96.90	110.74	4.966	29	144
	26.84	31.50	34.53	41.89	51.69	56.81	64.45	71.76	80.16	88.53	102.45	5.053	38	192
29.66	36.90	41.18	44.02	51.07	60.60	65.63	73.15	80.38	88.71	97.03	110.87	5.143	28	144
24.61	32.22	36.62	39.53	46.69	56.33	61.40	68.97	76.23	84.59	92.93	106.81	5.250	32	168
	27.05	31.72	34.75	42.12	51.92	57.05	64.69	72.00	80.41	88.79	102.71	5.333	36	192
24.82	32.44	36.85	39.76	46.93	56.57	61.64	69.22	76.48	84.84	93.19	107.07	5.600	30	168
	27.26	31.94	34.97	42.35	52.16	57.29	64.93	72.25	80.65	89.04	102.96	5.647	34	192
24.93	32.55	36.96	39.87	47.05	56.69	61.77	69.34	76.61	84.97	93.32	107.20	5.793	29	168
25.03	32.67	37.08	39.99	47.17	56.81	61.89	69.46	76.73	85.09	93.44	107.33	6.000	28	168
	27.47	32.16	35.20	42.58	52.40	57.53	65.18	72.50	80.90	89.29	103.22	6.000	32	192
	27.68	32.38	35.42	42.81	52.63	57.77	65.42	72.74	81.15	89.54	103.47	6.400	30	192
	27.79	32.49	35.53	42.93	52.75	57.89	65.54	72.86	81.28	89.66	103.60	6.621	29	192
	27.90	32.60	35.64	43.04	52.87	58.01	65.66	72.99	81.40	89.79	103.73	6.857	28	192
1.05	1.05	1.10	1.10	1.10	1.10	1.10	1.10	1.10	1.10	1.10	1.10			

*This length factor must be used to determine the proper belt width.

Center Distance is greater than eight times the small diameter and the large sprocket is not flanged. See Engineering Section I-10, Use of Flanged Sprockets, on page 134.



5M PowerGrip® GT² Power Rating Table — 25mm Belt Width

RPM of Faster Shaft	Base Rated Horsepower for Small Sprocket (Number of Grooves and Pitch Diameter, Inches)																								
	18	19	20	21	22	23	24	25	26	28	30	32	34	36	38	40	44	45	48	50	52	56	60	64	68
10	0.02	0.02	0.02	0.03	0.03	0.03	0.03	0.03	0.04	0.04	0.04	0.05	0.05	0.06	0.06	0.06	0.07	0.07	0.08	0.08	0.09	0.10	0.10	0.11	0.12
20	0.04	0.04	0.05	0.05	0.05	0.06	0.06	0.07	0.07	0.08	0.08	0.09	0.10	0.11	0.11	0.12	0.14	0.14	0.15	0.16	0.17	0.18	0.20	0.21	0.22
40	0.07	0.08	0.09	0.09	0.10	0.11	0.11	0.12	0.13	0.14	0.16	0.17	0.19	0.20	0.22	0.23	0.26	0.27	0.29	0.30	0.31	0.34	0.37	0.40	0.42
60	0.10	0.11	0.12	0.13	0.14	0.15	0.17	0.18	0.19	0.21	0.23	0.25	0.27	0.29	0.31	0.33	0.37	0.38	0.42	0.44	0.46	0.50	0.54	0.58	0.62
100	0.16	0.17	0.19	0.21	0.23	0.24	0.26	0.28	0.29	0.33	0.36	0.40	0.43	0.46	0.50	0.53	0.60	0.61	0.66	0.69	0.73	0.79	0.86	0.92	0.98
200	0.28	0.31	0.35	0.38	0.41	0.45	0.48	0.51	0.54	0.61	0.67	0.74	0.80	0.86	0.93	0.99	1.12	1.15	1.24	1.30	1.36	1.49	1.61	1.73	1.85
300	0.39	0.44	0.49	0.54	0.59	0.63	0.68	0.73	0.78	0.87	0.96	1.06	1.15	1.24	1.33	1.43	1.61	1.65	1.79	1.88	1.97	2.15	2.32	2.50	2.67
400	0.50	0.56	0.62	0.69	0.75	0.81	0.87	0.94	1.00	1.12	1.24	1.36	1.48	1.61	1.73	1.84	2.08	2.14	2.32	2.43	2.55	2.78	3.01	3.24	3.47
500	0.60	0.68	0.75	0.83	0.91	0.98	1.06	1.13	1.21	1.36	1.51	1.66	1.81	1.96	2.10	2.25	2.54	2.61	2.83	2.97	3.11	3.40	3.68	3.96	4.24
600	0.69	0.79	0.88	0.97	1.06	1.15	1.24	1.33	1.42	1.60	1.77	1.95	2.12	2.30	2.47	2.64	2.99	3.07	3.33	3.50	3.67	4.00	4.33	4.66	4.99
800	0.87	0.99	1.11	1.23	1.35	1.47	1.58	1.70	1.82	2.05	2.28	2.51	2.73	2.96	3.19	3.41	3.86	3.97	4.30	4.52	4.74	5.17	5.60	6.03	6.46
1000	1.04	1.19	1.33	1.48	1.62	1.77	1.91	2.05	2.20	2.48	2.76	3.04	3.32	3.60	3.88	4.15	4.70	4.83	5.24	5.50	5.77	6.30	6.83	7.35	7.87
1200	1.20	1.37	1.54	1.72	1.89	2.06	2.23	2.40	2.57	2.90	3.23	3.56	3.89	4.22	4.55	4.87	5.51	5.67	6.15	6.46	6.78	7.40	8.02	8.64	9.25
1400	1.35	1.55	1.75	1.95	2.14	2.34	2.53	2.73	2.92	3.31	3.69	4.07	4.45	4.83	5.20	5.57	6.31	6.49	7.04	7.40	7.76	8.47	9.18	9.89	10.6
1600	1.49	1.72	1.94	2.17	2.39	2.61	2.83	3.05	3.27	3.70	4.14	4.56	4.99	5.41	5.83	6.25	7.08	7.29	7.90	8.31	8.71	9.52	10.3	11.1	11.9
1800	1.63	1.89	2.13	2.38	2.63	2.87	3.12	3.36	3.61	4.09	4.57	5.05	5.52	5.99	6.46	6.92	7.84	8.07	8.75	9.20	9.65	10.5	11.4	12.3	13.2
2000	1.77	2.04	2.32	2.59	2.86	3.13	3.40	3.67	3.94	4.47	5.00	5.52	6.04	6.56	7.07	7.58	8.59	8.84	9.58	10.1	10.6	11.5	12.5	13.5	14.4
2400	2.02	2.35	2.67	2.99	3.31	3.63	3.95	4.26	4.58	5.20	5.82	6.44	7.04	7.65	8.25	8.85	10.0	10.3	11.2	11.8	12.3	13.5	14.6	15.7	16.8
2800	2.26	2.63	3.00	3.37	3.74	4.10	4.47	4.83	5.19	5.90	6.62	7.32	8.01	8.71	9.39	10.1	11.4	11.8	12.7	13.4	14.0	15.3	16.6	17.8	19.0
3200	2.48	2.90	3.32	3.74	4.15	4.56	4.97	5.37	5.78	6.58	7.38	8.17	8.95	9.73	10.5	11.3	12.8	13.1	14.2	14.9	15.7	17.1	18.5	19.8	21.2
3600	2.69	3.16	3.62	4.08	4.54	5.00	5.45	5.90	6.35	7.24	8.12	8.99	9.85	10.7	11.6	12.4	14.0	14.4	15.6	16.4	17.2	18.8	20.3	21.7	23.1
4000	2.89	3.40	3.91	4.42	4.92	5.42	5.92	6.41	6.90	7.87	8.84	9.79	10.7	11.7	12.6	13.5	15.3	15.7	17.0	17.9	18.7	20.3	21.9	23.5	25.0
5000	3.34	3.96	4.57	5.19	5.80	6.40	7.00	7.59	8.19	9.35	10.5	11.6	12.8	13.9	15.0	16.0	18.1	18.6	20.1	21.1	22.0	23.9	25.7	27.3	28.9
6000	3.72	4.45	5.17	5.88	6.60	7.29	7.99	8.67	9.36	10.7	12.0	13.3	14.6	15.9	17.1	18.3	20.6	21.1	22.8	23.8	24.8	26.8	28.6	30.2	
8000	4.32	5.24	6.14	7.04	7.93	8.80	9.67	10.5	11.4	13.0	14.6	16.1	17.6	19.1	20.5	21.8	24.3	24.9	26.6	27.6					
10000	4.70	5.79	6.85	7.90	8.94	9.94	10.9	11.9	12.9	14.7	16.5	18.2	19.7	21.2	22.6	23.9									
12000	4.85	6.08	7.26	8.44	9.58	10.7	11.8	12.8	13.8	15.8	17.6	19.2													
14000	4.77	6.10	7.37	8.63	9.84	11.0	12.1	13.2	14.2	16.1															

Shaded area indicates drive conditions where reduced service life can be expected.

$$\text{Corrected Horsepower Rating} = [\text{Base Rating}] \times [\text{Belt Length Correction Factor}]$$

5M PowerGrip GT2 Belt Length Correction Factor Table

Pitch/Length Designation	No. of Teeth	Correction Factor	Pitch/Length Designation	No. of Teeth	Correction Factor	Pitch/Length Designation	No. of Teeth	Correction Factor	Pitch/Length Designation	No. of Teeth	Correction Factor
5MR-300	60	0.77	5MR-500	100	0.90	5MR-700	140	1.00	5MR-1300	260	1.16
5MR-355	71	0.81	5MR-535	107	0.92	5MR-750	150	1.01	5MR-1450	290	1.19
5MR-375	75	0.83	5MR-565	113	0.94	5MR-800	160	1.03	5MR-1600	320	1.22
5MR-400	80	0.84	5MR-580	116	0.95	5MR-850	170	1.05	5MR-1720	344	1.24
5MR-405	81	0.85	5MR-600	120	0.95	5MR-900	180	1.06	5MR-2100	420	1.29
5MR-425	85	0.86	5MR-625	125	0.97	5MR-1000	200	1.09			
5MR-450	90	0.88	5MR-650	130	0.98	5MR-1150	230	1.13			



8M PowerGrip® GT² Power Rating Table — 20mm Belt Width

RPM of Faster Shaft	Base Rated Horsepower for Small Sprocket (Number of Grooves and Pitch Diameter, Inches)															
	22 2.206	24 2.406	26 2.607	28 2.807	30 3.008	32 3.208	34 3.409	36 3.609	38 3.810	40 4.010	44 4.411	48 4.812	56 5.614	64 6.416	72 7.218	80 8.020
*10	0.07	0.07	0.08	0.09	0.10	0.11	0.12	0.13	0.14	0.15	0.16	0.18	0.22	0.25	0.29	0.32
*20	0.12	0.14	0.16	0.18	0.20	0.21	0.23	0.25	0.27	0.28	0.32	0.35	0.42	0.49	0.55	0.62
*40	0.24	0.27	0.31	0.34	0.37	0.41	0.44	0.48	0.51	0.54	0.61	0.68	0.81	0.94	1.07	1.20
*60	0.35	0.40	0.45	0.50	0.55	0.60	0.65	0.69	0.74	0.79	0.89	0.99	1.18	1.38	1.57	1.76
*100	0.55	0.63	0.72	0.80	0.88	0.96	1.04	1.12	1.20	1.28	1.44	1.60	1.91	2.23	2.54	2.84
*200	1.04	1.20	1.36	1.52	1.67	1.83	1.98	2.14	2.29	2.45	2.75	3.06	3.67	4.27	4.87	5.46
*300	1.51	1.74	1.97	2.20	2.44	2.66	2.89	3.12	3.35	3.57	4.02	4.47	5.36	6.24	7.12	7.99
*400	1.96	2.27	2.57	2.87	3.18	3.48	3.78	4.07	4.37	4.67	5.26	5.85	7.02	8.17	9.32	10.5
*500	2.40	2.78	3.16	3.53	3.90	4.27	4.64	5.01	5.38	5.74	6.47	7.20	8.64	10.1	11.5	12.9
*600	2.83	3.28	3.73	4.17	4.62	5.06	5.50	5.93	6.37	6.80	7.67	8.53	10.2	11.9	13.6	15.3
700	3.26	3.78	4.29	4.80	5.32	5.83	6.34	6.84	7.35	7.85	8.85	9.84	11.8	13.8	15.7	17.6
800	3.68	4.26	4.85	5.43	6.01	6.59	7.17	7.74	8.31	8.88	10.0	11.1	13.4	15.6	17.8	20.0
870	3.96	4.60	5.23	5.86	6.49	7.12	7.74	8.36	8.98	9.60	10.8	12.0	14.5	16.9	19.2	21.6
1000	4.49	5.22	5.94	6.66	7.38	8.09	8.80	9.50	10.2	10.9	12.3	13.7	16.5	19.2	21.0	24.5
1160	5.13	5.97	6.80	7.62	8.45	9.26	10.1	10.9	11.7	12.5	14.1	15.7	18.9	22.0	25.1	28.1
1200	5.29	6.15	7.01	7.86	8.71	9.56	10.4	11.2	12.1	12.9	14.6	16.2	19.5	22.7	25.9	29.0
1400	6.07	7.07	8.06	9.04	10.0	11.0	12.0	12.9	13.9	14.9	16.8	18.7	22.4	26.1	29.8	33.4
1600	6.84	7.97	9.09	10.2	11.3	12.4	13.5	14.6	15.7	16.8	19.0	21.1	25.3	29.5	33.6	37.7
1750	7.41	8.64	9.86	11.1	12.3	13.5	14.7	15.9	17.1	18.2	20.6	22.9	27.5	32.0	36.5	40.8
2000	8.35	9.73	11.1	12.5	13.9	15.2	16.6	17.9	19.3	20.6	23.2	25.8	31.0	36.0	41.1	45.9
2400	9.81	11.4	13.1	14.7	16.3	17.9	19.5	21.1	22.7	24.3	27.4	30.5	36.5	42.4	48.2	53.8
2800	11.2	13.1	15.0	16.9	18.7	20.6	22.4	24.2	26.0	27.8	31.4	34.9	41.8	48.5	54.9	61.2
3200	12.6	14.8	16.9	19.0	21.1	23.2	25.2	27.3	29.3	31.3	35.3	39.2	46.9	54.2	61.3	68.0
3450	13.5	15.8	18.0	20.3	22.5	24.8	27.0	29.1	31.3	33.5	37.7	41.9	50.0	57.7	65.1	72.0
4000	15.3	17.9	20.5	23.1	25.6	28.2	30.7	33.1	35.6	38.0	42.8	47.4	56.4			
4500	16.9	19.8	22.7	25.5	28.4	31.1	33.9	36.6	39.3	42.0	47.2	52.2				
5000	18.5	21.7	24.8	27.9	31.0	34.0	37.0	40.0	42.9	45.7	51.3	56.7				
5500	20.0	23.5	26.9	30.2	33.6	36.8	40.0	43.2	46.3	49.3	55.3					

8M PowerGrip GT² Power Rating Table — 30mm Belt Width

RPM of Faster Shaft	Base Rated Horsepower for Small Sprocket (Number of Grooves and Pitch Diameter, Inches)															
	22 2.206	24 2.406	26 2.607	28 2.807	30 3.008	32 3.208	34 3.409	36 3.609	38 3.810	40 4.010	44 4.411	48 4.812	56 5.614	64 6.416	72 7.218	80 8.020
*10	0.10	0.12	0.13	0.15	0.16	0.17	0.19	0.20	0.22	0.23	0.26	0.29	0.34	0.40	0.45	0.51
*20	0.20	0.22	0.25	0.28	0.31	0.33	0.36	0.39	0.42	0.44	0.50	0.55	0.66	0.76	0.87	0.98
*40	0.37	0.43	0.48	0.53	0.59	0.64	0.69	0.75	0.80	0.85	0.96	1.06	1.27	1.47	1.68	1.88
*60	0.54	0.62	0.70	0.78	0.86	0.94	1.01	1.09	1.17	1.25	1.40	1.55	1.86	2.16	2.46	2.76
*100	0.87	1.00	1.12	1.25	1.38	1.51	1.63	1.76	1.89	2.01	2.26	2.51	3.00	3.49	3.98	4.47
*200	1.64	1.89	2.13	2.38	2.63	2.87	3.12	3.36	3.60	3.84	4.33	4.80	5.76	6.70	7.64	8.58
*300	2.37	2.74	3.10	3.46	3.82	4.18	4.54	4.90	5.25	5.61	6.32	7.02	8.42	9.80	11.2	12.5
*400	3.08	3.56	4.04	4.51	4.99	5.46	5.93	6.40	6.87	7.33	8.26	9.18	11.0	12.8	14.6	16.4
*500	3.77	4.36	4.95	5.54	6.13	6.71	7.29	7.87	8.45	9.02	10.2	11.3	13.6	15.8	18.0	20.2
*600	4.45	5.15	5.85	6.55	7.25	7.94	8.63	9.31	10.0	10.7	12.0	13.4	16.1	18.7	21.4	24.0
700	5.11	5.93	6.74	7.54	8.35	9.15	9.95	10.7	11.5	12.3	13.9	15.5	18.6	21.6	24.7	27.7
800	5.77	6.69	7.61	8.52	9.44	10.3	11.2	12.1	13.0	13.9	15.7	17.5	21.0	24.5	27.9	31.4
870	6.22	7.22	8.22	9.20	10.2	11.2	12.2	13.1	14.1	15.1	17.0	18.9	22.7	26.5	30.2	33.9
1000	7.05	8.19	9.33	10.5	11.6	12.7	13.8	14.9	16.0	17.1	19.3	21.5	25.8	30.1	34.3	38.5
1160	8.06	9.37	10.7	12.0	13.3	14.5	15.8	17.1	18.4	19.6	22.2	24.7	29.6	34.5	39.4	44.2
1200	8.31	9.66	11.0	12.3	13.7	15.0	16.3	17.6	19.0	20.3	22.9	25.4	30.6	35.6	40.6	45.6
1400	9.54	11.1	12.7	14.2	15.7	17.3	18.8	20.3	21.8	23.3	26.3	29.3	35.2	41.0	46.8	52.4
1600	10.7	12.5	14.3	16.0	17.8	19.5	21.2	23.0	24.7	26.4	29.8	33.1	39.8	46.3	52.8	59.1
1750	11.6	13.6	15.5	17.4	19.3	21.2	23.0	24.9	26.8	28.6	32.3	36.0	43.2	50.3	57.2	64.1
2000	13.1	15.3	17.5	19.6	21.8	23.9	26.0	28.1	30.2	32.3	36.5	40.6	48.7	56.7	64.5	72.1
2400	15.4	18.0	20.5	23.1	25.6	28.1	30.7	33.1	35.6	38.1	43.0	47.8	57.3	66.6	75.6	84.4
2800	17.6	20.6	23.6	26.5	29.4	32.3	35.2	38.0	40.9	43.7	49.3	54.8	65.6	76.1	86.2	96.0
3200	19.8	23.2	26.5	29.8	33.1	36.4	39.6	42.8	46.0	49.2	55.4	61.6	73.6	85.2	96.2	
3450	21.1	24.7	28.3	31.9	35.4	38.9	42.3	45.8	49.2	52.5	59.2	65.7	78.4	90.6	102.2	
4000	24.0	28.1	32.2	36.2	40.3	44.2	48.1	52.0	55.9	59.7	67.1	74.5	88.5			
4500	26.6	31.1	35.6	40.1	44.5	48.9	53.2	57.5	61.7	65.9	74.0	82.0				
5000	29.0	34.0	39.0	43.8	48.7	53.4	58.1	62.8	67.3	71.8	80.6	89.1				
5500	31.4	36.8	42.2	47.5	52.7	57.8	62.9	67.8	72.7	77.5	86.8					

*Refer to page 15 for additional Service Factors for speeds of 600 rpm or less.

Corrected Horsepower Rating = [Base Rating] × [Belt Length Correction Factor]



8M PowerGrip® GT² Power Rating Table — 50mm Belt Width

RPM of Faster Shaft	Base Rated Horsepower for Small Sprocket (Number of Grooves and Pitch Diameter, Inches)												
	28 2.807	30 3.008	32 3.208	34 3.409	36 3.609	38 3.810	40 4.010	44 4.411	48 4.812	56 5.614	64 6.416	72 7.218	80 8.020
*10	0.25	0.28	0.30	0.33	0.35	0.38	0.40	0.45	0.50	0.59	0.69	0.78	0.88
*20	0.49	0.53	0.58	0.63	0.68	0.72	0.77	0.86	0.96	1.14	1.33	1.51	1.70
*40	0.93	1.02	1.11	1.21	1.30	1.39	1.48	1.66	1.84	2.20	2.56	2.92	3.27
*60	1.35	1.49	1.63	1.76	1.90	2.03	2.17	2.43	2.70	3.23	3.75	4.28	4.80
*100	2.18	2.40	2.62	2.84	3.06	3.28	3.50	3.93	4.36	5.22	6.08	6.92	7.77
*200	4.14	4.57	4.99	5.42	5.84	6.26	6.68	7.52	8.35	10.0	11.7	13.3	14.9
*300	6.02	6.65	7.27	7.90	8.52	9.14	9.75	11.0	12.2	14.6	17.0	19.4	21.8
*400	7.85	8.67	9.49	10.3	11.1	11.9	12.7	14.4	16.0	19.2	22.3	25.5	28.6
*500	9.63	10.7	11.7	12.7	13.7	14.7	15.7	17.7	19.7	23.6	27.5	31.4	35.2
*600	11.4	12.6	13.8	15.0	16.2	17.4	18.6	20.9	23.3	28.0	32.6	37.2	41.7
700	13.1	14.5	15.9	17.3	18.7	20.1	21.4	24.2	26.9	32.3	37.6	42.9	48.2
800	14.8	16.4	18.0	19.6	21.1	22.7	24.2	27.3	30.4	36.5	42.6	48.6	54.5
870	16.0	17.7	19.4	21.1	22.8	24.5	26.2	29.5	32.9	39.5	46.0	52.5	58.9
1000	18.2	20.1	22.1	24.0	25.9	27.9	29.8	33.6	37.4	44.9	52.4	59.7	67.0
1160	20.8	23.1	25.3	27.5	29.7	32.0	34.1	38.5	42.9	51.5	60.0	68.5	76.8
1200	21.5	23.8	26.1	28.4	30.7	33.0	35.2	39.8	44.2	53.1	61.9	70.6	79.2
1400	24.7	27.4	30.0	32.7	35.3	38.0	40.6	45.8	51.0	61.2	71.3	81.3	91.2
1600	27.9	30.9	33.9	36.9	39.9	42.9	45.9	51.8	57.6	69.2	80.6	91.8	102.9
1750	30.2	33.5	36.8	40.1	43.3	46.6	49.8	56.2	62.5	75.0	87.4	99.5	111.4
2000	34.1	37.8	41.5	45.2	48.9	52.6	56.2	63.4	70.6	84.7	98.5	112.1	125.4
2400	40.2	44.6	48.9	53.3	57.6	62.0	66.2	74.7	83.1	99.7	115.8	131.5	146.8
2800	46.1	51.2	56.2	61.2	66.2	71.1	76.0	85.7	95.3	114.1	132.3	149.9	166.9
3200	51.9	57.6	63.2	68.9	74.5	80.0	85.5	96.4	107.1	128.0	148.1	167.4	
3450	55.4	61.5	67.6	73.6	79.6	85.5	91.3	102.9	114.3	136.4	157.5	177.7	
4000	63.0	70.0	76.9	83.7	90.4	97.1	103.7	116.8	129.5	154.0			
4500	69.7	77.4	85.0	92.6	100.0	107.3	114.5	128.7	142.5				
5000	76.2	84.7	92.9	101.1	109.1	117.1	124.9	140.1	154.9				
5500	82.5	91.6	100.5	109.3	117.9	126.4	134.7	150.9					

*Refer to page 15 for additional Service Factors for speeds of 600 rpm or less.

$$\text{Corrected Horsepower Rating} = [\text{Base Rating}] \times [\text{Belt Length Correction Factor}]$$

8M PowerGrip GT2 Belt Length Correction Factor

Pitch/Length Designation	No. of Teeth	Correction Factor	Pitch/Length Designation	No. of Teeth	Correction Factor	Pitch/Length Designation	No. of Teeth	Correction Factor	Pitch/Length Designation	No. of Teeth	Correction Factor
384-8MGT	48	0.70	920-8MGT	115	1.00	1440-8MGT	180	1.10	2600-8MGT	325	1.20
480-8MGT	60	0.80	960-8MGT	120	1.00	1512-8MGT	189	1.10	2800-8MGT	350	1.20
560-8MGT	70	0.80	1040-8MGT	130	1.00	1584-8MGT	198	1.10	3048-8MGT	381	1.20
600-8MGT	75	0.80	1064-8MGT	133	1.00	1600-8MGT	200	1.10	3280-8MGT	410	1.20
640-8MGT	80	0.90	1120-8MGT	140	1.00	1760-8MGT	220	1.10	3600-8MGT	450	1.20
720-8MGT	90	0.90	1160-8MGT	145	1.00	1800-8MGT	225	1.20	4400-8MGT	550	1.20
800-8MGT	100	0.90	1200-8MGT	150	1.00	2000-8MGT	250	1.20			
840-8MGT	105	0.90	1224-8MGT	153	1.00	2200-8MGT	275	1.20			
880-8MGT	110	0.90	1280-8MGT	160	1.10	2400-8MGT	300	1.20			



8M PowerGrip GT2 Power Rating Table — 85mm Belt Width

RPM of Faster Shaft	Base Rated Horsepower for Small Sprocket (Number of Grooves and Pitch Diameter, Inches)									
	34 3.409	36 3.609	38 3.810	40 4.010	44 4.411	48 4.812	56 5.614	64 6.416	72 7.218	80 8.020
*10	0.57	0.61	0.65	0.70	0.78	0.87	1.03	1.20	1.36	1.53
*20	1.09	1.18	1.26	1.34	1.50	1.67	1.99	2.31	2.63	2.95
*40	2.10	2.26	2.42	2.57	2.89	3.21	3.83	4.46	5.07	5.69
*60	3.07	3.30	3.53	3.77	4.23	4.70	5.62	6.53	7.44	8.34
*100	4.94	5.32	5.70	6.08	6.84	7.59	9.09	10.6	12.0	13.5
*200	9.43	10.2	10.9	11.6	13.1	14.5	17.4	20.3	23.1	25.9
*300	13.7	14.8	15.9	17.0	19.1	21.2	25.5	29.7	33.8	38.0
*400	17.9	19.4	20.8	22.2	25.0	27.8	33.3	38.8	44.3	49.7
*500	22.1	23.8	25.6	27.3	30.8	34.2	41.0	47.8	54.6	61.2
*600	26.1	28.2	30.3	32.3	36.4	40.5	48.6	56.7	64.7	72.6
700	30.1	32.5	34.9	37.3	42.0	46.8	56.1	65.4	74.7	83.8
800	34.0	36.8	39.5	42.2	47.6	52.9	63.6	74.1	84.5	94.9
870	36.8	39.7	42.7	45.6	51.4	57.2	68.7	80.1	91.4	102.5
1000	41.8	45.1	48.5	51.8	58.5	65.1	78.2	91.1	103.9	116.6
1160	47.9	51.7	55.6	59.4	67.0	74.6	89.6	104.5	119.1	133.6
1200	49.4	53.4	57.4	61.3	69.2	77.0	92.5	107.8	122.9	137.8
1400	56.9	61.5	66.1	70.6	79.7	88.7	106.5	124.1	141.5	158.6
1600	64.3	69.4	74.6	79.8	90.1	100.2	120.4	140.2	159.7	179.0
1750	69.7	75.4	81.0	86.6	97.7	108.8	130.6	152.0	173.1	193.9
2000	78.7	85.1	91.4	97.8	110.3	122.8	147.3	171.4	195.0	218.2
2400	92.8	100.3	107.8	115.2	130.0	144.6	173.4	201.4	228.8	255.4
2800	106.5	115.1	123.7	132.3	149.2	165.9	198.5	230.2	260.9	290.5
3200	119.9	129.6	139.3	148.8	167.7	186.4	222.7	257.6	291.2	
3450	128.1	138.4	148.7	158.9	179.1	198.8	237.3	274.1	309.1	
4000	145.6	157.4	169.0	180.5	203.1	225.3	267.9			
4500	161.0	173.9	186.7	199.3	224.0	248.0				
5000	175.9	189.9	203.7	217.3	243.8	269.4				
5500	190.2	205.2	220.0	234.4	262.5					

*Refer to page 15 for additional Service Factors for speeds of 600 rpm or less.

$$\text{Corrected Horsepower Rating} = [\text{Base Rating}] \times [\text{Belt Length Correction Factor}]$$

8M PowerGrip GT2 Belt Length Correction Factor

Pitch/Length Designation	No. of Teeth	Correction Factor	Pitch/Length Designation	No. of Teeth	Correction Factor	Pitch/Length Designation	No. of Teeth	Correction Factor	Pitch/Length Designation	No. of Teeth	Correction Factor
384-8MGT	48	0.70	920-8MGT	115	1.00	1440-8MGT	180	1.10	2600-8MGT	325	1.20
480-8MGT	60	0.80	960-8MGT	120	1.00	1512-8MGT	189	1.10	2800-8MGT	350	1.20
560-8MGT	70	0.80	1040-8MGT	130	1.00	1584-8MGT	198	1.10	3048-8MGT	381	1.20
600-8MGT	75	0.80	1064-8MGT	133	1.00	1600-8MGT	200	1.10	3280-8MGT	410	1.20
640-8MGT	80	0.90	1120-8MGT	140	1.00	1760-8MGT	220	1.10	3600-8MGT	450	1.20
720-8MGT	90	0.90	1160-8MGT	145	1.00	1800-8MGT	225	1.20	4400-8MGT	550	1.20
800-8MGT	100	0.90	1200-8MGT	150	1.00	2000-8MGT	250	1.20			
840-8MGT	105	0.90	1224-8MGT	153	1.00	2200-8MGT	275	1.20			
880-8MGT	110	0.90	1280-8MGT	160	1.10	2400-8MGT	300	1.20			



14M PowerGrip® GT² Power Rating Table — 40mm Belt Width

RPM of Faster Shaft	Base Rated Horsepower for Small Sprocket (Number of Grooves and Pitch Diameter, Inches)																
	28 4.912	29 5.088	30 5.263	32 5.614	34 5.965	36 6.316	38 6.667	40 7.018	44 7.720	48 8.421	52 9.123	56 9.825	60 10.527	64 11.229	68 11.930	72 12.632	80 14.036
*10	0.56	0.58	0.60	0.65	0.70	0.74	0.79	0.83	0.92	1.01	1.10	1.19	1.28	1.37	1.46	1.55	1.72
*20	1.04	1.09	1.13	1.22	1.31	1.40	1.48	1.57	1.74	1.91	2.08	2.25	2.42	2.59	2.75	2.92	3.25
*40	1.95	2.04	2.12	2.29	2.46	2.62	2.79	2.95	3.27	3.60	3.92	4.24	4.55	4.87	5.18	5.49	6.11
*60	2.81	2.94	3.06	3.30	3.54	3.78	4.02	4.26	4.73	5.19	5.66	6.12	6.58	7.03	7.49	7.94	8.83
*100	4.44	4.64	4.83	5.22	5.60	5.98	6.36	6.74	7.49	8.23	8.97	9.71	10.4	11.2	11.9	12.6	14.0
*200	8.21	8.58	8.94	9.67	10.4	11.1	11.8	12.5	13.9	15.3	16.7	18.1	19.4	20.8	22.1	23.5	26.1
*300	11.7	12.3	12.8	13.8	14.9	15.9	16.9	17.9	20.0	22.0	23.9	25.9	27.9	29.8	31.7	33.6	37.4
*400	15.1	15.8	16.4	17.8	19.1	20.5	21.8	23.1	25.7	28.3	30.9	33.4	35.9	38.4	40.9	43.4	48.3
*500	18.3	19.1	20.0	21.6	23.3	24.9	26.5	28.1	31.3	34.5	37.6	40.7	43.7	46.8	49.8	52.8	58.7
*600	21.4	22.4	23.4	25.3	27.3	29.2	31.1	33.0	36.7	40.4	44.1	47.7	51.3	54.8	58.4	61.9	68.8
800	27.5	28.7	30.0	32.5	35.0	37.4	39.9	42.3	47.1	51.9	56.6	61.2	65.8	70.3	74.8	79.3	88.0
870	29.5	30.9	32.2	34.9	37.6	40.2	42.9	45.5	50.6	55.7	60.8	65.8	70.7	75.6	80.4	85.1	94.5
1000	33.2	34.8	36.3	39.3	42.3	45.3	48.3	51.2	57.1	62.8	68.5	74.1	79.6	85.0	90.4	95.7	106.2
1160	37.7	39.4	41.1	44.6	48.0	51.4	54.8	58.1	64.7	71.2	77.6	84.0	90.2	96.3	102.3	108.3	119.9
1200	38.7	40.6	42.3	45.9	49.4	52.9	56.4	59.8	66.6	73.3	79.9	86.4	92.8	99.0	105.2	111.3	123.2
1400	44.1	46.2	48.2	52.3	56.3	60.3	64.2	68.1	75.8	83.4	90.8	98.1	105.3	112.3	119.2	126.0	139.2
1600	49.3	51.6	53.9	58.4	62.9	67.3	71.7	76.1	84.7	93.1	101.3	109.4	117.2	125.0	132.5	139.8	154.0
1750	53.1	55.5	58.0	62.9	67.7	72.5	77.2	81.9	91.1	100.1	108.9	117.4	125.8	134.0	141.9	149.6	164.3
2000	59.2	61.9	64.7	70.1	75.5	80.8	86.1	91.3	101.4	111.3	120.9	130.2	139.3	148.0	156.5		
2400	68.5	71.7	74.9	81.2	87.3	93.4	99.4	105.3	116.8	127.9	138.6						
2800	77.3	80.9	84.4	91.5	98.4	105.2	111.8	118.3	130.9	142.9							
+3200	85.5	89.5	93.4	101.1	108.6	116.0	123.2	130.1	143.5								
+3600	93.2	97.5	101.7	110.0	118.1	125.9	133.5										
+4000	100.4	105.0	109.5	118.2	126.7	134.8											

14M PowerGrip GT² Power Rating Table — 55mm Belt Width

RPM of Faster Shaft	Base Rated Horsepower for Small Sprocket (Number of Grooves and Pitch Diameter, Inches)																
	28 4.912	29 5.088	30 5.263	32 5.614	34 5.965	36 6.316	38 6.667	40 7.018	44 7.720	48 8.421	52 9.123	56 9.825	60 10.527	64 11.229	68 11.930	72 12.632	80 14.036
*10	0.83	0.87	0.90	0.97	1.04	1.11	1.18	1.25	1.39	1.52	1.66	1.79	1.92	2.06	2.19	2.32	2.58
*20	1.57	1.63	1.70	1.83	1.96	2.09	2.23	2.36	2.61	2.87	3.13	3.38	3.63	3.88	4.13	4.38	4.87
*40	2.93	3.06	3.18	3.43	3.68	3.93	4.18	4.42	4.91	5.40	5.88	6.36	6.83	7.30	7.77	8.24	9.17
*60	4.22	4.40	4.59	4.95	5.31	5.67	6.03	6.38	7.09	7.79	8.49	9.18	9.87	10.6	11.2	11.9	13.2
*100	6.66	6.96	7.25	7.82	8.40	8.97	9.54	10.1	11.2	12.4	13.5	14.6	15.7	16.7	17.8	18.9	21.0
*200	12.3	12.9	13.4	14.5	15.6	16.7	17.7	18.8	20.9	23.0	25.0	27.1	29.1	31.2	33.2	35.2	39.1
*300	17.6	18.4	19.2	20.7	22.3	23.8	25.4	26.9	29.9	32.9	35.9	38.9	41.8	44.7	47.6	50.5	56.1
*400	22.6	23.7	24.7	26.7	28.7	30.7	32.7	34.7	38.6	42.5	46.3	50.1	53.9	57.7	61.4	65.1	72.4
*500	27.5	28.7	30.0	32.4	34.9	37.3	39.8	42.2	47.0	51.7	56.4	61.0	65.6	70.2	74.7	79.2	88.0
*600	32.2	33.6	35.1	38.0	40.9	43.8	46.6	49.4	55.1	60.6	66.1	71.5	76.9	82.3	87.6	92.8	103.2
800	41.2	43.1	45.0	48.7	52.4	56.1	59.8	63.5	70.7	77.8	84.8	91.8	98.7	105.5	112.2	118.9	132.0
870	44.2	46.3	48.3	52.4	56.4	60.3	64.3	68.2	76.0	83.6	91.2	98.7	106.0	113.3	120.6	127.7	141.7
1000	49.8	52.1	54.4	59.0	63.5	68.0	72.4	76.9	85.6	94.2	102.7	111.1	119.4	127.6	135.6	143.6	159.2
1160	56.5	59.1	61.7	66.9	72.0	77.1	82.2	87.2	97.1	106.9	116.5	125.9	135.3	144.5	153.5	162.4	179.8
1200	58.1	60.8	63.5	68.8	74.1	79.4	84.6	89.7	99.9	110.0	119.8	129.6	139.1	148.6	157.8	167.0	184.8
1400	66.1	69.2	72.3	78.4	84.4	90.4	96.3	102.2	113.7	125.1	136.2	147.2	158.0	168.5	178.9	189.0	208.7
1600	73.9	77.4	80.8	87.6	94.3	101.0	107.6	114.2	127.0	139.6	152.0	164.0	175.9	187.4	198.7	209.7	231.0
1750	79.6	83.3	87.0	94.3	101.6	108.8	115.9	122.9	136.7	150.1	163.3	176.2	188.7	200.9	212.8	224.4	246.5
2000	88.7	92.9	97.0	105.2	113.3	121.3	129.1	136.9	152.1	166.9	181.3	195.3	208.9	222.0	234.7		
2400	102.7	107.5	112.3	121.7	131.0	140.2	149.1	158.0	175.2	191.9	207.9	223.3					
+2800	115.9	121.3	126.7	137.2	147.6	157.7	167.7	177.5	196.3	214.3							
+3200	128.3	134.2	140.1	151.7	163.0	174.0	184.7	195.2	215.3								
+3600	139.8	146.3	152.6	165.0	177.1	188.8	200.2										
+4000	150.6	157.5	164.2	177.3	190.0	202.2											

* Refer to Page 15 for additional Service Factors for speeds of 600 rpm or less.

+ Drives within this speed range may generate an objectionable noise level. This can be reduced by using commercially available acoustical damping material in the belt guard. Contact Gates for recommendations on any drive to be installed in a noise sensitive area.

$$\text{Corrected Horsepower Rating} = [\text{Base Rating}] \times [\text{Belt Length Correction Factor}]$$

14M PowerGrip GT² Belt Length Correction Factor Table

Pitch/Length Designation	No. of Teeth	Correction Factor	Pitch/Length Designation	No. of Teeth	Correction Factor	Pitch/Length Designation	No. of Teeth	Correction Factor	Pitch/Length Designation	No. of Teeth	Correction Factor
966-14MGT	69	0.80	1890-14MGT	135	0.95	2800-14MGT	200	1.05	4326-14MGT	309	1.10
1190-14MGT	85	0.80	2100-14MGT	150	1.00	3150-14MGT	225	1.05	4578-14MGT	327	1.10
1400-14MGT	100	0.90	2310-14MGT	165	1.00	3360-14MGT	240	1.10	4956-14MGT	354	1.10
1610-14MGT	115	0.90	2450-14MGT	175	1.00	3500-14MGT	250	1.10	5320-14MGT	380	1.10
1778-14MGT	127	0.95	2590-14MGT	185	1.05	3850-14MGT	275	1.10	5740-14MGT	410	1.10



14M PowerGrip® GT² Power Rating Table — 85mm Belt Width

RPM of Faster Shaft	Base Rated Horsepower for Small Sprocket (Number of Grooves and Pitch Diameter, Inches)																
	28 4.912	29 5.088	30 5.263	32 5.614	34 5.965	36 6.316	38 6.667	40 7.018	44 7.720	48 8.421	52 9.123	56 9.825	60 10.527	64 11.229	68 11.930	72 12.632	80 14.036
*10	1.39	1.45	1.51	1.62	1.74	1.85	1.97	2.08	2.31	2.54	2.76	2.98	3.20	3.43	3.64	3.86	4.30
*20	2.61	2.72	2.83	3.05	3.27	3.49	3.71	3.93	4.36	4.78	5.21	5.63	6.05	6.47	6.88	7.30	8.12
*40	4.89	5.10	5.30	5.72	6.14	6.55	6.96	7.37	8.19	8.99	9.80	10.6	11.4	12.2	13.0	13.7	15.3
*60	7.03	7.34	7.64	8.25	8.85	9.45	10.0	10.6	11.8	13.0	14.1	15.3	16.4	17.6	18.7	19.8	22.1
*100	11.1	11.6	12.1	13.0	14.0	15.0	15.9	16.8	18.7	20.6	22.4	24.3	26.1	27.9	29.7	31.5	35.0
*200	20.5	21.5	22.4	24.2	26.0	27.8	29.5	31.3	34.8	38.3	41.7	45.2	48.6	51.9	55.3	58.6	65.2
*300	29.3	30.7	32.0	34.6	37.2	39.7	42.3	44.8	49.9	54.9	59.9	64.8	69.7	74.5	79.3	84.1	93.6
*400	37.7	39.4	41.1	44.5	47.8	51.2	54.5	57.8	64.3	70.8	77.2	83.6	89.9	96.1	102.3	108.5	120.7
*500	45.8	47.9	49.9	54.1	58.2	62.2	66.3	70.3	78.3	86.1	93.9	101.7	109.3	116.9	124.5	131.9	146.7
*600	53.6	56.1	58.5	63.3	68.2	72.9	77.7	82.4	91.8	101.0	110.2	119.2	128.2	137.1	145.9	154.7	171.9
800	68.6	71.8	74.9	81.2	87.4	93.6	99.7	105.8	117.8	129.6	141.4	153.0	164.5	175.8	187.1	198.2	220.1
870	73.7	77.2	80.5	87.3	93.9	100.6	107.1	113.7	126.6	139.4	152.0	164.4	176.7	188.9	200.9	212.8	236.2
1000	83.0	86.9	90.7	98.3	105.8	113.3	120.7	128.1	142.7	157.0	171.2	185.2	199.0	212.6	226.1	239.3	265.4
1160	94.1	98.5	102.9	111.5	120.1	128.6	137.0	145.3	161.9	178.1	194.1	209.9	225.4	240.8	255.8	270.7	299.7
1200	96.9	101.4	105.8	114.7	123.6	132.3	141.0	149.6	166.6	183.3	199.7	215.9	231.9	247.6	263.1	278.3	308.0
1400	110.2	115.4	120.5	130.6	140.7	150.6	160.5	170.3	189.6	208.5	227.1	245.3	263.3	280.9	298.1	315.1	347.9
1600	123.2	129.0	134.7	146.0	157.2	168.4	179.4	190.3	211.7	232.7	253.3	273.4	293.1	312.4	331.2	349.6	385.0
1750	132.6	138.8	145.0	157.2	169.3	181.3	193.1	204.8	227.8	250.2	272.2	293.6	314.5	334.9	354.7	374.0	410.8
+2000	147.9	154.9	161.7	175.3	188.8	202.1	215.2	228.1	253.5	278.2	302.2	325.6	348.2	370.1	391.2		
+2400	171.2	179.2	187.2	202.9	218.4	233.6	248.6	263.3	292.1	319.8	346.5	372.1					
+2800	193.2	202.2	211.1	228.7	246.0	262.9	279.5	295.8	327.2	357.2							
+3200	213.8	223.7	233.5	252.8	271.6	290.0	307.9	325.4	358.8								
+3600	233.1	243.8	254.4	275.1	295.2	314.7	333.7										
+4000	251.0	262.4	273.6	295.5	316.7	337.1											

14M PowerGrip GT² Power Rating Table — 115mm Belt Width

RPM of Faster Shaft	Base Rated Horsepower for Small Sprocket (Number of Grooves and Pitch Diameter, Inches)																
	28 4.912	29 5.088	30 5.263	32 5.614	34 5.965	36 6.316	38 6.667	40 7.018	44 7.720	48 8.421	52 9.123	56 9.825	60 10.527	64 11.229	68 11.930	72 12.632	80 14.036
*10	1.94	2.03	2.11	2.27	2.43	2.59	2.75	2.92	3.23	3.55	3.86	4.18	4.49	4.80	5.10	5.41	6.02
*20	3.65	3.81	3.96	4.27	4.58	4.89	5.19	5.50	6.10	6.70	7.29	7.88	8.47	9.06	9.64	10.2	11.4
*40	6.84	7.13	7.43	8.01	8.59	9.17	9.75	10.3	11.5	12.6	13.7	14.8	15.9	17.0	18.1	19.2	21.4
*60	9.85	10.3	10.7	11.5	12.4	13.2	14.1	14.9	16.5	18.2	19.8	21.4	23.0	24.6	26.2	27.8	30.9
*100	15.5	16.2	16.9	18.3	19.6	20.9	22.3	23.6	26.2	28.8	31.4	34.0	36.5	39.1	41.6	44.1	49.0
*200	28.8	30.0	31.3	33.8	36.4	38.9	41.3	43.8	48.7	53.6	58.4	63.2	68.0	72.7	77.4	82.1	91.3
*300	41.1	42.9	44.7	48.4	52.0	55.6	59.2	62.8	69.9	76.9	83.8	90.7	97.5	104.3	111.1	117.8	131.0
*400	52.8	55.2	57.6	62.3	67.0	71.7	76.3	80.9	90.1	99.1	108.1	117.0	125.8	134.6	143.2	151.8	168.9
*500	64.1	67.0	69.9	75.7	81.4	87.1	92.8	98.4	109.6	120.6	131.5	142.3	153.1	163.7	174.2	184.7	205.4
*600	75.1	78.5	81.9	88.7	95.4	102.1	108.8	115.4	128.5	141.4	154.2	166.9	179.5	192.0	204.3	216.5	240.7
800	96.1	100.5	104.9	113.7	122.4	131.0	139.5	148.1	164.9	181.5	197.9	214.2	230.3	246.2	261.9	277.4	308.1
870	103.2	108.0	112.7	122.2	131.5	140.8	150.0	159.1	177.3	195.1	212.8	230.2	247.4	264.5	281.3	298.0	330.7
1000	116.2	121.6	127.0	137.6	148.2	158.6	169.0	179.3	199.7	219.8	239.7	259.2	278.6	297.7	316.5	335.1	371.6
1160	131.8	137.9	144.0	156.1	168.1	180.0	191.8	203.5	226.6	249.3	271.8	293.8	315.6	337.1	358.1	379.0	419.6
1200	135.6	141.9	148.2	160.6	173.0	185.2	197.4	209.4	233.2	256.6	279.6	302.3	324.7	346.7	368.3	389.6	431.2
+1400	154.3	161.5	168.7	182.9	197.0	210.9	224.7	238.4	265.4	291.9	317.9	343.5	368.6	393.2	417.4	441.1	487.1
+1600	172.5	180.5	188.5	204.4	220.1	235.7	251.1	266.4	296.4	325.8	354.6	382.8	410.4	437.4	463.7	489.4	538.9
+1750	185.7	194.4	203.0	220.1	237.0	253.8	270.3	286.7	318.9	350.3	381.0	411.0	440.3	468.8	496.6	523.5	575.1
+2000	207.1	216.8	226.4	245.5	264.3	282.9	301.3	319.4	354.9	389.5	423.1	455.8	487.4	518.1	547.7		
+2400	239.7	250.9	262.0	284.0	305.7	327.0	348.0	368.7	408.9	447.7	485.1	521.0					
+2800	270.4	283.1	295.5	320.2	344.4	368.1	391.3	414.1	458.1	500.1							
+3200	299.3	313.2	326.9	353.9	380.2	406.0	431.1	455.5	502.4								
+3600	326.3	341.3	356.1	385.1	413.3	440.6	467.1										
+4000	351.4	367.4	383.1	413.7	443.3	471.9											

* Refer to Page 15 for additional Service Factors for speeds of 600 rpm or less.

+ Drives within this speed range may generate an objectionable noise level. This can be reduced by using commercially available acoustical damping material in the belt guard. Contact Gates for recommendations on any drive to be installed in a noise sensitive area.

$$\text{Corrected Horsepower Rating} = [\text{Base Rating}] \times [\text{Belt Length Correction Factor}]$$



14M PowerGrip® GT² Power Rating Table — 170mm Belt Width

RPM of Faster Shaft	Base Rated Horsepower for Small Sprocket (Number of Grooves and Pitch Diameter, Inches)											
	36 6.316	38 6.667	40 7.018	44 7.720	48 8.421	52 9.123	56 9.825	60 10.527	64 11.229	68 11.930	72 12.632	80 14.036
*10	3.94	4.19	4.43	4.91	5.39	5.87	6.35	6.82	7.29	7.76	8.22	9.15
*20	7.43	7.89	8.35	9.27	10.2	11.1	12.0	12.9	13.8	14.6	15.5	17.3
*40	13.9	14.8	15.7	17.4	19.1	20.8	22.5	24.2	25.9	27.6	29.2	32.5
*60	20.1	21.4	22.6	25.1	27.6	30.1	32.6	35.0	37.4	39.8	42.2	47.0
*100	31.8	33.8	35.9	39.8	43.8	47.7	51.6	55.5	59.4	63.2	67.0	74.5
*200	59.1	62.8	66.6	74.1	81.5	88.8	96.1	103.4	110.5	117.7	124.8	138.8
*300	84.6	90.0	95.4	106.2	116.8	127.4	137.9	148.3	158.6	168.8	179.0	199.1
*400	108.9	116.0	123.0	136.9	150.6	164.3	177.8	191.2	204.5	217.7	230.8	256.8
*500	132.4	141.0	149.6	166.5	183.3	199.9	216.3	232.7	248.8	264.8	280.8	312.2
*600	155.2	165.3	175.4	195.3	214.9	234.4	253.7	272.8	291.8	310.5	329.1	365.9
800	199.1	212.1	225.0	250.6	275.9	300.9	325.6	350.0	374.2	398.0	421.7	468.3
870	214.0	228.0	241.9	269.4	296.6	323.4	349.9	376.1	402.0	427.6	452.9	502.7
1000	241.1	256.9	272.6	303.6	334.1	364.3	394.1	423.4	452.4	481.0	509.3	564.8
1160	273.6	291.5	309.3	344.4	379.0	413.1	446.7	479.7	512.3	544.4	576.0	637.8
+1200	281.6	300.0	318.3	354.4	390.0	425.0	459.5	493.5	526.9	559.8	592.2	655.5
+1400	320.6	341.6	362.4	403.4	443.6	483.2	522.1	560.2	597.7	634.4	670.4	740.4
+1600	358.3	381.7	404.9	450.5	495.2	539.0	581.8	623.8	664.8	704.8	743.9	819.2
+1750	385.8	410.9	435.8	484.7	532.5	579.2	624.8	669.3	712.6	754.8	795.8	874.2
+2000	430.0	457.9	485.5	539.5	592.0	643.1	692.8	740.9	787.5	832.4		
+2400	497.1	529.0	560.3	621.5	680.5	737.3	791.9					
+2800	559.5	594.8	629.4	696.3	760.1							
+3200	617.1	655.2	692.4	763.6								
+3600	669.7	710.0										
+4000	717.3											

* Refer to Page 15 for additional Service Factors for speeds of 600 rpm or less.

+ Drives within this speed range may generate an objectionable noise level. This can be reduced by using commercially available acoustical damping material in the belt guard. Contact Gates for recommendations on any drive to be installed in a noise sensitive area.

$$\text{Corrected Horsepower Rating} = [\text{Base Rating}] \times [\text{Belt Length Correction Factor}]$$

14M PowerGrip GT2 Belt Length Correction Factor Table

Pitch/Length Designation	No. of Teeth	Correction Factor	Pitch/Length Designation	No. of Teeth	Correction Factor	Pitch/Length Designation	No. of Teeth	Correction Factor	Pitch/Length Designation	No. of Teeth	Correction Factor
966-14MGT	69	0.80	1890-14MGT	135	0.95	2800-14MGT	200	1.05	4326-14MGT	309	1.10
1190-14MGT	85	0.80	2100-14MGT	150	1.00	3150-14MGT	225	1.05	4578-14MGT	327	1.10
1400-14MGT	100	0.90	2310-14MGT	165	1.00	3360-14MGT	240	1.10	4956-14MGT	354	1.10
1610-14MGT	115	0.90	2450-14MGT	175	1.00	3500-14MGT	250	1.10	5320-14MGT	380	1.10
1778-14MGT	127	0.95	2590-14MGT	185	1.05	3850-14MGT	275	1.10	5740-14MGT	410	1.10



20mm Pitch PowerGrip® GT®2 Belts Drive Selection Table



The Gates Rubber Company

Pulley Combinations				Speed Ratio	Center Distance, Inches														
DriveR		DriveN			2000-20M P.L. 78.740 100 teeth	2500-20M P.L. 98.425 125 teeth	3400-20M P.L. 133.858 170 teeth	3800-20M P.L. 149.606 190 teeth	4200-20M P.L. 165.354 210 teeth	4600-20M P.L. 181.102 230 teeth	5000-20M P.L. 196.850 250 teeth	5200-20M P.L. 204.724 260 teeth	5400-20M P.L. 212.598 270 teeth	5600-20M P.L. 220.472 280 teeth	5800-20M P.L. 228.346 290 teeth	6000-20M P.L. 236.220 300 teeth	6200-20M P.L. 244.094 310 teeth	6400-20M P.L. 251.969 320 teeth	6600-20M P.L. 259.843 330 teeth
No. of grooves	Pitch Diameter (inches)	No. of grooves	Pitch Diameter (inches)																
34	8.522	34	8.522	1.000	25.98	35.83	53.54	61.42	69.29	77.16	85.04	88.98	92.91	96.85	100.79	104.72	108.66	112.60	116.54
36	9.023	36	9.023	1.000	25.20	35.04	52.76	60.63	68.50	76.38	84.25	88.19	92.13	96.06	100.00	103.94	107.87	111.81	115.75
38	9.524	38	9.524	1.000	24.41	34.25	51.97	59.84	67.72	75.59	83.46	87.40	91.34	95.28	99.21	103.15	107.09	111.02	114.96
40	10.025	40	10.025	1.000	23.62	33.47	51.18	59.06	66.93	74.80	82.68	86.61	90.55	94.49	98.43	102.36	106.30	110.24	114.17
44	11.028	44	11.028	1.000	22.05	31.89	49.61	57.48	65.35	73.23	81.10	85.04	88.98	92.91	96.85	100.79	104.72	108.66	112.60
48	12.031	48	12.031	1.000	20.47	30.31	48.03	55.90	63.78	71.65	79.53	83.46	87.40	91.34	95.27	99.21	103.15	107.09	111.02
52	13.033	52	13.033	1.000	18.90	28.74	46.46	54.33	62.20	70.08	77.95	81.89	85.83	89.76	93.70	97.64	101.57	105.51	109.45
56	14.036	56	14.036	1.000	17.32	27.16	44.88	52.76	60.63	68.50	76.38	80.31	84.25	88.19	92.13	96.06	100.00	103.94	107.87
60	15.038	60	15.038	1.000		25.59	43.31	51.18	59.06	66.93	74.80	78.74	82.68	86.61	90.55	94.49	98.43	102.36	106.30
64	16.041	64	16.041	1.000		24.02	41.73	49.61	57.48	65.35	73.23	77.16	81.10	85.04	88.98	92.91	96.85	100.79	104.72
68	17.043	68	17.043	1.000		22.44	40.16	48.03	55.91	63.78	71.65	75.59	79.53	83.46	87.40	91.34	95.28	99.21	103.15
72	18.046	72	18.046	1.000		20.87	38.58	46.46	54.33	62.20	70.08	74.02	77.95	81.89	85.83	89.76	93.70	97.64	101.57
80	20.051	80	20.051	1.000			35.43	43.31	51.18	59.05	66.93	70.87	74.80	78.74	82.68	86.61	90.55	94.49	98.43
90	22.557	90	22.557	1.000			31.50	39.37	47.24	55.12	62.99	66.93	70.87	74.80	78.74	82.68	86.61	90.55	94.49
38	9.524	40	10.025	1.053	24.01	33.86	51.57	59.45	67.32	75.20	83.07	87.01	90.94	94.88	98.82	102.76	106.69	110.63	114.57
36	9.023	38	9.524	1.056	24.80	34.64	52.36	60.24	68.11	75.98	83.86	87.79	91.73	95.67	99.61	103.54	107.48	111.42	115.35
34	8.522	36	9.023	1.059	25.59	35.43	53.15	61.02	68.90	76.77	84.64	88.58	92.52	96.46	100.39	104.33	108.27	112.20	116.14
68	17.043	72	18.046	1.059		21.65	39.37	47.24	55.12	62.99	70.86	74.80	78.74	82.68	86.61	90.55	94.49	98.42	102.36
64	16.041	68	17.043	1.063		23.22	40.94	48.82	56.69	64.56	72.44	76.38	80.31	84.25	88.19	92.12	96.06	100.00	103.94
60	15.038	64	16.041	1.067		24.80	42.52	50.39	58.27	66.14	74.01	77.95	81.89	85.83	89.76	93.70	97.64	101.57	105.51
56	14.036	60	15.038	1.071	16.53	26.37	44.09	51.97	59.84	67.71	75.59	79.53	83.46	87.40	91.34	95.27	99.21	103.15	107.09
52	13.033	56	14.036	1.077	18.10	27.95	45.67	53.54	61.42	69.29	77.16	81.10	85.04	88.97	92.91	96.85	100.79	104.72	108.66
48	12.031	52	13.033	1.083	19.68	29.52	47.24	55.12	62.99	70.86	78.74	82.68	86.61	90.55	94.49	98.42	102.36	106.30	110.24
44	11.028	48	12.031	1.091	21.25	31.10	48.82	56.69	64.56	72.44	80.31	84.25	88.19	92.12	96.06	100.00	103.94	107.87	111.81
40	10.025	44	11.028	1.100	22.83	32.67	50.39	58.27	66.14	74.01	81.89	85.83	89.76	93.70	97.64	101.57	105.51	109.45	113.39
36	9.023	40	10.025	1.111	24.40	34.25	51.97	59.84	67.71	75.59	83.46	87.40	91.34	95.27	99.21	103.15	107.09	111.02	114.96
72	18.046	80	20.051	1.111			36.99	44.87	52.75	60.62	68.50	72.43	76.37	80.31	84.25	88.18	92.12	96.06	100.00
34	8.522	38	9.524	1.118	25.19	35.04	52.75	60.63	68.50	76.38	84.25	88.19	92.12	96.06	100.00	103.94	107.87	111.81	115.75
64	16.041	72	18.046	1.125		22.42	40.14	48.02	55.90	63.77	71.65	75.58	79.52	83.46	87.40	91.33	95.27	99.21	103.14
80	20.051	90	22.557	1.125			33.44	41.32	49.20	57.07	64.95	68.89	72.82	76.76	80.70	84.64	88.57	92.51	96.45
60	15.038	68	17.043	1.133		24.00	41.72	49.60	57.47	65.35	73.22	77.16	81.10	85.03	88.97	92.91	96.85	100.78	104.72
56	14.036	64	16.041	1.143		25.57	43.29	51.17	59.05	66.92	74.80	78.73	82.67	86.61	90.55	94.48	98.42	102.36	106.29
52	13.033	60	15.038	1.154	17.29	27.15	44.87	52.75	60.62	68.50	76.37	80.31	84.25	88.18	92.12	96.06	100.00	103.93	107.87
38	9.524	44	11.028	1.158	23.22	33.06	50.78	58.66	66.53	74.41	82.28	86.22	90.15	94.09	98.03	101.97	105.90	109.84	113.78
48	12.031	56	14.036	1.167	18.87	28.72	46.45	54.32	62.20	70.07	77.95	81.88	85.82	89.76	93.69	97.63	101.57	105.51	109.44
34	8.522	40	10.025	1.176	24.79	34.64	52.36	60.23	68.11	75.98	83.85	87.79	91.73	95.67	99.60	103.54	107.48	111.42	115.35
68	17.043	80	20.051	1.176		20.02	37.77	45.64	53.52	61.40	69.28	73.21	77.15	81.09	85.03	88.96	92.90	96.84	100.78
44	11.028	52	13.033	1.182	20.45	30.30	48.02	55.90	63.77	71.65	79.52	83.46	87.40	91.33	95.27	99.21	103.14	107.08	111.02
40	10.025	48	12.031	1.200	22.02	31.87	49.60	57.47	65.35	73.22	81.10	85.03	88.97	92.91	96.85	100.78	104.72	108.66	112.59
60	15.038	72	18.046	1.200		23.18	40.92	48.80	56.67	64.55	72.43	76.36	80.30	84.24	88.18	92.11	96.05	99.99	103.93
56	14.036	68	17.043	1.214		24.76	42.49	50.37	58.25	66.12	74.00	77.94	81.88	85.81	89.75	93.69	97.63	101.56	105.50
36	9.023	44	11.028	1.222	23.60	33.45	51.17	59.05	66.92	74.80	82.67	86.61	90.55	94.48	98.42	102.36	106.29	110.23	114.17
52	13.033	64	16.041	1.231	16.47	26.33	44.07	51.95	59.82	67.70	75.58	79.51	83.45	87.39	91.33	95.26	99.20	103.14	107.08
90	22.557	112	28.071	1.244			27.03	34.93	42.83	50.71	58.60	62.54	66.48	70.42	74.36	78.30	82.24	86.18	90.12
Length Factor*					0.80	0.85	.095	1.0				1.05				1.1			

*This length factor must be used to determine the proper belt width.

20mm Pitch PowerGrip® GT®2 Belts — (continued)

Drive Selection Table

Pulley Combinations				Speed Ratio	Center Distance, Inches														
DriveR		DriveN			2000-20M P.L. 76.740 100 teeth	2500-20M P.L. 98.425 125 teeth	3400-20M P.L. 133.958 170 teeth	3800-20M P.L. 149.806 190 teeth	4200-20M P.L. 165.354 210 teeth	4600-20M P.L. 181.102 230 teeth	5000-20M P.L. 196.850 250 teeth	5200-20M P.L. 204.724 260 teeth	5400-20M P.L. 212.598 270 teeth	5600-20M P.L. 220.472 280 teeth	5800-20M P.L. 228.346 290 teeth	6000-20M P.L. 236.220 300 teeth	6200-20M P.L. 244.094 310 teeth	6400-20M P.L. 251.969 320 teeth	6600-20M P.L. 259.843 330 teeth
No. of grooves	Pitch Diameter (inches)	No. of grooves	Pitch Diameter (inches)																
48	12.031	60	15.038	1.250	18.05	27.91	45.64	53.52	61.40	69.27	77.15	81.09	85.03	88.96	92.90	96.84	100.78	104.71	108.65
64	16.041	80	20.051	1.250		20.77	38.53	46.41	54.29	62.17	70.05	73.99	77.93	81.86	85.80	89.74	93.68	97.62	101.56
72	18.046	90	22.557	1.250			34.97	42.85	50.74	58.62	66.50	70.44	74.38	78.31	82.25	86.19	90.13	94.07	98.01
38	9.524	48	12.031	1.263	22.41	32.26	49.98	57.86	65.74	73.61	81.49	85.42	89.36	93.30	97.24	101.17	105.11	109.05	112.99
44	11.028	56	14.036	1.273	19.63	29.49	47.22	55.10	62.97	70.85	78.73	82.66	86.60	90.54	94.48	98.41	102.35	106.29	110.23
56	14.036	72	18.046	1.286		23.93	41.68	49.57	57.44	65.32	73.20	77.14	81.08	85.02	88.95	92.89	96.83	100.77	104.71
34	8.522	44	11.028	1.294	23.98	33.83	51.56	59.44	67.31	75.19	83.06	87.00	90.94	94.87	98.81	102.75	106.69	110.62	114.56
40	10.025	52	13.033	1.300	21.21	31.07	48.80	56.67	64.55	72.43	80.30	84.24	88.18	92.11	96.05	99.99	103.93	107.86	111.80
52	13.033	68	17.043	1.308		25.51	43.26	51.14	59.02	66.90	74.78	78.71	82.65	86.59	90.53	94.47	98.40	102.34	106.28
68	17.043	90	22.557	1.324			35.72	43.61	51.50	59.39	67.27	71.21	75.15	79.09	83.03	86.96	90.90	94.84	98.78
36	9.023	48	12.031	1.333	22.78	32.64	50.37	58.25	66.12	74.00	81.88	85.81	89.75	93.69	97.63	101.56	105.50	109.44	113.38
48	12.031	64	16.041	1.333	17.21	27.09	44.84	52.72	60.60	68.47	76.35	80.29	84.23	88.17	92.10	96.04	99.98	103.92	107.86
60	15.038	80	20.051	1.333		21.51	39.29	47.18	55.06	62.94	70.82	74.76	78.70	82.64	86.58	90.52	94.45	98.39	102.33
44	11.028	60	15.038	1.364	18.79	28.67	46.41	54.29	62.17	70.05	77.93	81.87	85.80	89.74	93.68	97.62	101.56	105.49	109.43
38	9.524	52	13.033	1.368	21.58	31.45	49.18	57.06	64.94	72.81	80.69	84.63	88.57	92.50	96.44	100.38	104.32	108.25	112.19
52	13.033	72	18.046	1.385		24.68	42.45	50.33	58.21	66.09	73.97	77.91	81.85	85.79	89.73	93.67	97.61	101.54	105.48
40	10.025	56	14.036	1.400	20.37	30.25	47.99	55.87	63.75	71.63	79.50	83.44	87.38	91.32	95.25	99.19	103.13	107.07	111.01
80	20.051	112	28.071	1.400			28.85	36.79	44.70	52.60	60.50	64.44	68.39	72.33	76.27	80.21	84.16	88.10	92.04
64	16.041	90	22.557	1.406			36.47	44.37	52.26	60.15	68.03	71.97	75.91	79.85	83.79	87.73	91.67	95.61	99.55
34	8.522	48	12.031	1.412	23.16	33.02	50.76	58.63	66.51	74.39	82.26	86.20	90.14	94.08	98.02	101.95	105.89	109.83	113.77
48	12.031	68	17.043	1.417	16.34	26.26	44.02	51.91	59.79	67.67	75.55	79.49	83.43	87.37	91.30	95.24	99.18	103.12	107.06
56	14.036	80	20.051	1.429		22.24	40.04	47.94	55.82	63.71	71.59	75.53	79.47	83.41	87.35	91.29	95.23	99.17	103.11
36	9.023	52	13.033	1.444	21.96	31.83	49.57	57.45	65.32	73.20	81.08	85.02	88.95	92.89	96.83	100.77	104.71	108.64	112.58
44	11.028	64	16.041	1.455	17.93	27.84	45.60	53.48	61.37	69.25	77.12	81.06	85.00	88.94	92.88	96.82	100.76	104.69	108.63
38	9.524	56	14.036	1.474	20.74	30.63	48.37	56.25	64.13	72.01	79.89	83.83	87.77	91.70	95.64	99.58	103.52	107.46	111.39
40	10.025	60	15.038	1.500	19.52	29.42	47.18	55.06	62.94	70.82	78.70	82.64	86.58	90.52	94.46	98.39	102.33	106.27	110.21
60	12.031	72	18.046	1.500		25.41	43.20	51.09	58.98	66.86	74.74	78.68	82.62	86.56	90.50	94.44	98.38	102.32	106.26
60	15.038	90	22.557	1.500			37.21	45.12	53.02	60.91	68.80	72.74	76.68	80.62	84.56	88.50	92.44	96.38	100.32
34	8.522	52	13.033	1.529	22.33	32.20	49.95	57.83	65.71	73.59	81.46	85.40	89.34	93.28	97.22	101.16	105.09	109.03	112.97
52	13.033	80	20.051	1.538		22.96	40.79	48.69	56.58	64.47	72.36	76.30	80.24	84.18	88.12	92.06	96.00	99.94	103.88
44	11.028	68	17.043	1.545	17.06	27.00	44.78	52.67	60.56	68.44	76.32	80.26	84.20	88.14	92.08	96.02	99.95	103.89	107.83
36	9.023	56	14.036	1.556	21.11	31.00	48.75	56.64	64.52	72.40	80.28	84.21	88.15	92.09	96.03	99.97	103.91	107.84	111.78
72	18.046	112	28.071	1.556			30.29	38.25	46.18	54.10	62.00	65.95	69.90	73.85	77.79	81.74	85.68	89.62	93.57
38	9.524	60	15.038	1.579	19.89	29.79	47.56	55.44	63.33	71.21	79.09	83.03	86.96	90.90	94.84	98.78	102.72	106.66	110.60
40	10.025	64	16.041	1.600	18.65	28.58	46.36	54.25	62.13	70.01	77.89	81.83	85.77	89.71	93.65	97.59	101.53	105.47	109.41
90	22.557	144	36.092	1.600				35.98	43.97	51.92	55.89	59.85	63.81	67.77	71.73	75.68	79.63	83.58	87.53
56	14.036	90	22.557	1.607		20.02	37.95	45.86	53.77	61.66	69.55	73.50	77.44	81.38	85.33	89.27	93.21	97.15	101.09
44	11.028	72	18.046	1.636	16.15	26.14	43.95	51.85	59.74	67.63	75.51	79.45	83.39	87.33	91.27	95.21	99.15	103.09	107.03
34	8.522	56	14.036	1.647	21.48	31.37	49.13	57.02	64.90	72.78	80.66	84.60	88.54	92.48	96.42	100.36	104.29	108.23	112.17
68	17.043	112	28.071	1.647			31.00	38.98	46.92	54.84	62.75	66.70	70.65	74.60	78.55	82.49	86.44	90.38	94.33
36	9.023	60	15.038	1.667	20.25	30.16	47.94	55.82	63.71	71.59	79.47	83.41	87.35	91.29	95.23	99.17	103.11	107.04	110.98
48	12.031	80	20.051	1.667		23.67	41.54	49.44	57.34	65.23	73.12	77.06	81.00	84.94	88.89	92.83	96.77	100.71	104.65
38	9.524	64	16.041	1.684		19.01	28.95	46.74	54.63	62.51	70.40	78.28	82.22	86.16	90.10	94.04	97.98	101.92	105.86
40	10.025	68	17.043	1.700	17.76	27.73	45.53	53.43	61.32	69.20	77.09	81.03	84.97	88.91	92.85	96.79	100.73	104.67	108.61
Length Factor*					0.80	0.85	.095	1.0				1.05				1.1			

*This length factor must be used to determine the proper belt width.



20mm Pitch PowerGrip® GT®2 Belts — (continued)

Drive Selection Table

Pulley Combinations				Speed Ratio	Center Distance, Inches														
DriveR		DriveN			2000-20M P.L. 78.740 100 teeth	2500-20M P.L. 98.425 125 teeth	3400-20M P.L. 133.858 170 teeth	3800-20M P.L. 149.606 190 teeth	4200-20M P.L. 165.354 210 teeth	4600-20M P.L. 181.102 230 teeth	5000-20M P.L. 196.850 250 teeth	5200-20M P.L. 204.724 260 teeth	5400-20M P.L. 212.598 270 teeth	5600-20M P.L. 220.472 280 teeth	5800-20M P.L. 228.346 290 teeth	6000-20M P.L. 236.220 300 teeth	6200-20M P.L. 244.094 310 teeth	6400-20M P.L. 251.969 320 teeth	6600-20M P.L. 259.843 330 teeth
No. of grooves	Pitch Diameter (inches)	No. of grooves	Pitch Diameter (inches)																
52	13.033	90	22.557	1.731		20.71	38.68	46.61	54.52	62.42	70.31	74.26	78.20	82.15	86.09	90.03	93.97	97.92	101.86
64	16.041	112	28.071	1.750			31.71	39.70	47.65	55.58	63.49	67.45	71.40	75.35	79.30	83.25	87.19	91.14	95.09
34	8.522	60	15.038	1.765	20.61	30.53	48.32	56.20	64.09	71.97	79.85	83.79	87.73	91.67	95.61	99.55	103.49	107.43	111.37
36	9.023	64	16.041	1.778	19.37	29.32	47.11	55.01	62.89	70.78	78.66	82.60	86.54	90.48	94.42	98.36	102.30	106.24	110.18
38	9.524	68	17.043	1.789	18.11	28.09	45.91	53.81	61.70	69.58	77.47	81.41	85.35	89.29	93.23	97.17	101.11	105.05	108.99
40	10.025	72	18.046	1.800	16.84	26.87	44.70	52.60	60.50	68.39	76.27	80.21	84.16	88.10	92.04	95.98	99.92	103.86	107.80
80	20.051	144	36.092	1.800			29.62	37.73	45.75	53.73	57.71	61.68	65.65	69.62	73.58	77.54	81.49	85.45	89.41
44	11.028	80	20.051	1.818		24.38	42.28	50.19	58.09	65.99	73.88	77.82	81.77	85.71	89.65	93.59	97.53	101.47	105.42
60	15.038	112	28.071	1.867			32.41	40.42	48.38	56.32	64.24	68.19	72.15	76.10	80.05	84.00	87.95	91.90	95.84
90	22.557	168	42.107	1.867						38.52	46.61	50.63	54.64	58.63	62.62	66.60	70.58	74.56	78.53
48	12.031	90	22.557	1.875		21.40	39.41	47.34	55.26	63.17	71.06	75.01	78.96	82.90	86.85	90.79	94.74	98.68	102.62
34	8.522	64	16.041	1.882	19.72	29.68	47.49	55.38	63.27	71.16	79.04	82.99	86.93	90.87	94.81	98.75	102.69	106.63	110.57
36	9.023	68	17.043	1.889	18.46	28.46	46.28	54.18	62.08	69.96	77.85	81.79	85.73	89.67	93.61	97.56	101.50	105.44	109.38
38	9.524	72	18.046	1.895	17.19	27.22	45.07	52.98	60.87	68.77	76.65	80.60	84.54	88.48	92.42	96.36	100.30	104.24	108.18
34	8.522	68	17.043	2.000	18.81	28.82	46.66	54.56	62.45	70.34	78.23	82.17	86.11	90.06	94.00	97.94	101.88	105.82	109.76
36	9.023	72	18.046	2.000	17.53	27.58	45.44	53.35	61.25	69.14	77.03	80.98	84.92	88.86	92.80	96.74	100.69	104.63	108.57
40	10.025	80	20.051	2.000		25.09	43.01	50.93	58.84	66.74	74.63	78.58	82.53	86.47	90.41	94.36	98.30	102.24	106.18
56	14.036	112	28.071	2.000			33.11	41.13	49.10	57.05	64.97	68.93	72.89	76.84	80.80	84.75	88.70	92.65	96.60
72	18.046	144	36.092	2.000			30.96	39.11	47.17	55.17	63.13	71.08	79.05	87.01	94.97	102.92	110.87	118.82	126.77
44	11.028	90	22.557	2.045		22.08	40.14	48.08	56.00	63.91	71.82	75.77	79.71	83.66	87.61	91.55	95.50	99.44	103.38
80	20.051	168	42.107	2.100					31.93	40.21	48.34	52.38	56.40	60.41	64.41	68.40	72.39	76.37	80.34
38	9.524	80	20.051	2.105		25.44	43.38	51.30	59.21	67.12	75.01	78.96	82.90	86.85	90.79	94.74	98.68	102.62	106.56
34	8.522	72	18.046	2.118	17.87	27.94	45.81	53.73	61.63	69.52	77.41	81.36	85.30	89.24	93.18	97.13	101.07	105.01	108.95
68	17.043	144	36.092	2.118			31.63	39.80	47.87	55.88	63.86	67.83	71.81	75.78	79.75	83.71	87.67	91.62	95.57
90	22.557	192	48.122	2.133					40.90	45.02	49.11	53.18	57.23	61.26	65.28	69.29	73.29	77.29	81.29
52	13.033	112	28.071	2.154			33.81	41.84	49.83	57.78	65.71	69.67	73.63	77.59	81.54	85.50	89.45	93.40	97.35
36	9.023	80	20.051	2.222		25.79	43.75	51.67	59.59	67.49	75.39	79.34	83.28	87.23	91.17	95.12	99.06	103.00	106.94
40	10.025	90	22.557	2.250		22.75	40.86	48.81	56.74	64.66	72.56	76.52	80.47	84.41	88.36	92.31	96.25	100.20	104.14
64	16.041	144	36.092	2.250				32.29	40.48	48.57	56.59	60.59	64.57	68.56	72.53	76.51	80.48	84.44	88.41
48	12.031	112	28.071	2.333			34.50	42.55	50.54	58.50	66.44	70.41	74.37	78.33	82.29	86.24	90.19	94.15	98.10
72	18.046	168	42.107	2.333				33.23	41.55	49.72	53.77	57.80	61.82	65.83	69.83	73.82	77.81	81.79	85.77
34	8.522	80	20.051	2.353	15.87	26.13	44.11	52.04	59.96	67.86	75.76	79.71	83.66	87.61	91.55	95.49	99.44	103.38	107.33
38	9.524	90	22.557	2.368		23.09	41.22	49.17	57.11	65.03	72.94	76.89	80.84	84.79	88.74	92.68	96.63	100.58	104.52
60	15.038	144	36.092	2.400				32.95	41.17	49.26	57.30	61.30	65.29	69.28	73.26	77.23	81.21	85.18	89.14
80	20.051	192	48.122	2.400							42.55	46.69	50.80	54.89	58.95	63.00	67.03	71.05	75.06
90	22.557	216	54.138	2.400									43.14	47.34	51.50	55.62	59.71	63.78	67.84
68	17.043	168	42.107	2.471					33.88	42.22	50.40	54.46	58.50	62.52	66.53	70.54	74.53	78.53	82.51
36	9.023	90	22.557	2.500		23.43	41.57	49.54	57.48	65.40	73.31	77.26	81.21	85.16	89.11	93.06	97.01	100.95	104.90
44	11.028	112	28.071	2.545			35.18	43.25	51.26	59.23	67.18	71.14	75.11	79.07	83.03	86.98	90.94	94.89	98.85
56	14.036	144	36.092	2.571				33.61	41.84	49.96	58.00	62.01	66.01	70.00	73.98	77.96	81.93	85.91	89.87
64	16.041	168	42.107	2.625					34.52	42.89	51.08	55.15	59.19	63.22	67.24	71.25	75.25	79.24	83.23
34	8.522	90	22.557	2.647		23.76	41.93	49.90	57.84	65.77	73.68	77.64	81.59	85.54	89.49	93.44	97.38	101.33	105.28
72	18.046	192	48.122	2.667						35.33	43.85	48.02	52.15	56.25	60.32	64.38	68.42	72.45	76.47
80	20.051	216	54.138	2.700								40.45	44.74	48.97	53.15	57.29	61.40	65.49	69.55
Length Factor*					0.80	0.85	.095	1.0				1.05				1.1			

*This length factor must be used to determine the proper belt width.

Center Distance is greater than eight times the small diameter and the large sprocket is not flanged. See Engineering Section I-10, Use of Flanged Sprockets, on page 134.



20mm Pitch PowerGrip® GT®2 Belts — (continued)

Drive Selection Table

Pulley Combinations				Speed Ratio	Center Distance, Inches														
DriveR		DriveN			2000-20M P.L. 76.740 100 teeth	2500-20M P.L. 98.425 125 teeth	3400-20M P.L. 133.958 170 teeth	3800-20M P.L. 149.806 190 teeth	4200-20M P.L. 165.354 210 teeth	4600-20M P.L. 181.102 230 teeth	5000-20M P.L. 196.850 250 teeth	5200-20M P.L. 204.724 260 teeth	5400-20M P.L. 212.598 270 teeth	5600-20M P.L. 220.472 280 teeth	5800-20M P.L. 228.346 290 teeth	6000-20M P.L. 236.220 300 teeth	6200-20M P.L. 244.094 310 teeth	6400-20M P.L. 251.969 320 teeth	6600-20M P.L. 259.843 330 teeth
No. of grooves	Pitch Diameter (inches)	No. of grooves	Pitch Diameter (inches)																
52	13.033	144	36.092	2.769															
40	10.025	112	28.071	2.800															
60	15.038	168	42.107	2.800															
68	17.043	192	48.122	2.824															
38	9.524	112	28.071	2.947			36.21	44.30	52.33	60.31	68.27	72.24	76.21	80.17	84.13	88.09	92.05	96.01	99.96
48	12.031	144	36.092	3.000			26.33	34.91	43.19	51.34	59.41	63.42	67.43	71.42	75.42	79.40	83.38	87.36	91.33
56	14.036	168	42.107	3.000					35.79	44.21	52.44	56.52	60.57	64.61	68.64	72.66	76.66	80.67	84.66
64	16.041	192	48.122	3.000					36.58	45.15	49.34	53.48	57.59	61.68	65.75	69.80	73.84	77.87	
72	18.046	216	54.138	3.000						37.27	41.70	46.02	50.27	54.46	58.62	62.74	66.84	70.92	
36	9.023	112	28.071	3.111			36.55	44.65	52.68	60.67	68.63	72.60	76.57	80.54	84.50	88.46	92.42	96.38	100.34
68	17.043	216	54.138	3.176						37.88	42.32	46.66	50.91	55.12	59.28	63.41	67.52	71.60	
60	15.038	192	48.122	3.200						37.20	45.80	49.99	54.15	58.27	62.36	66.43	70.49	74.54	78.57
52	13.033	168	42.107	3.231						36.43	44.87	53.12	57.20	61.26	65.30	69.34	73.36	77.37	81.38
44	11.028	144	36.092	3.273			26.95	35.56	43.87	52.03	60.11	64.13	68.14	72.14	76.13	80.12	84.10	88.08	92.06
34	8.522	112	28.071	3.294			36.89	45.00	53.03	61.03	68.99	72.97	76.94	80.90	84.87	88.83	92.79	96.75	100.71
64	16.041	216	54.138	3.375						38.49	42.95	47.29	51.56	55.77	59.94	64.08	68.19	72.28	
56	14.036	192	48.122	3.429						37.82	46.44	50.65	54.81	58.94	63.04	67.12	71.18	75.23	79.26
48	12.031	168	42.107	3.500			28.16	37.06	45.52	53.79	57.88	61.94	65.99	70.03	74.06	78.07	82.08	86.08	
40	10.025	144	36.092	3.600			27.57	36.21	44.54	52.71	60.80	64.83	68.84	72.85	76.84	80.84	84.82	88.81	92.78
60	15.038	216	54.138	3.600						39.10	43.57	47.92	52.20	56.42	60.60	64.74	68.86	72.96	
52	13.033	192	48.122	3.692						38.44	47.09	51.30	55.47	59.60	63.71	67.80	71.86	75.92	79.96
38	9.524	144	36.092	3.789			27.87	36.53	44.87	53.05	61.15	65.18	69.19	73.20	77.20	81.19	85.18	89.17	93.15
44	11.028	168	42.107	3.818				28.76	37.69	46.18	54.46	58.56	62.63	66.68	70.73	74.76	78.78	82.79	86.79
56	14.036	216	54.138	3.857						39.70	44.19	48.55	52.84	57.07	61.25	65.41	69.53	73.63	
36	9.023	144	36.092	4.000			28.18	36.86	45.20	53.39	61.50	65.53	69.54	73.55	77.56	81.55	85.54	89.53	93.51
48	12.031	192	48.122	4.000						39.06	47.73	51.95	56.13	60.27	64.38	68.47	72.55	76.60	80.65
52	13.033	216	54.138	4.154						40.31	44.80	49.18	53.48	57.72	61.91	66.07	70.20	74.30	
40	10.025	168	42.107	4.200					29.36	38.32	46.83	55.13	59.23	63.31	67.37	71.42	75.45	79.48	83.49
34	8.522	144	36.092	4.235			28.48	37.18	45.53	53.73	61.84	65.87	69.90	73.91	77.91	81.91	85.90	89.89	93.87
44	11.028	192	48.122	4.364					30.35	39.67	48.37	52.60	56.79	60.93	65.05	69.15	73.23	77.29	81.34
38	9.524	168	42.107	4.421				29.65	38.64	47.16	55.46	59.57	63.65	67.72	71.76	75.80	79.83	83.85	87.86
48	12.031	216	54.138	4.500						40.91	45.42	49.81	54.12	58.36	62.56	66.73	70.86	74.98	
36	9.023	168	42.107	4.667				29.95	38.95	47.48	55.80	59.91	63.99	68.06	72.11	76.15	80.18	84.20	88.21
40	10.025	192	48.122	4.800					30.93	40.29	49.01	53.25	57.44	61.60	65.72	69.83	73.91	77.98	82.03
44	11.028	216	54.138	4.909						41.51	46.04	50.44	54.75	59.01	63.22	67.39	71.53	75.65	
34	8.522	168	42.107	4.941				30.24	39.26	47.81	56.13	60.24	64.33	68.40	72.45	76.50	80.53	84.55	88.56
38	9.524	192	48.122	5.053					31.22	40.60	49.32	53.57	57.77	61.93	66.06	70.16	74.25	78.32	82.38
36	9.023	192	48.122	5.333					31.51	40.90	49.64	53.89	58.10	62.26	66.39	70.50	74.59	78.66	82.72
40	10.025	216	54.138	5.400						42.11	46.65	51.06	55.39	59.65	63.87	68.05	72.19	76.32	
34	8.522	192	48.122	5.647					31.80	41.21	49.96	54.22	58.42	62.59	66.73	70.84	74.93	79.00	83.06
38	9.524	216	54.138	5.684						32.56	42.41	46.96	51.38	55.71	59.97	64.19	68.37	72.53	76.65
36	9.023	216	54.138	6.000						32.84	42.71	47.26	51.69	56.02	60.30	64.52	68.70	72.86	76.99
34	8.522	216	54.138	6.353						33.12	43.01	47.57	52.00	56.34	60.62	64.84	69.03	73.19	77.32
Length Factor*					0.80	0.85	.095	1.0		1.05							1.1		

*This length factor must be used to determine the proper belt width.

Center Distance is greater than eight times the small diameter and the large sprocket is not flanged. See Engineering Section I-10, Use of Flanged Sprockets, on page 134.



The Driving Force in Power Transmission.

20M PowerGrip® GT² Power Rating Table — 115mm Belt Width

RPM of Faster Shaft	Base Rated Horsepower For Small Sprocket (Number of Grooves and Pitch Diameter, Inches)													
	34 8.522	36 9.023	38 9.524	40 10.026	44 11.028	48 12.031	52 13.033	56 14.036	60 15.038	64 16.041	68 17.043	72 18.046	80 20.051	90 22.557
*10	2.7	2.9	3.1	3.3	3.6	4.0	4.3	4.6	4.9	5.1	5.4	5.6	6.1	6.7
*20	5.4	5.8	6.1	6.5	7.3	7.9	8.6	9.2	9.8	10.3	10.8	11.3	12.3	13.5
*30	8.1	8.6	9.2	9.8	10.9	11.9	12.9	13.8	14.6	15.4	16.2	16.9	18.4	20.2
*40	10.7	11.5	12.3	13.0	14.5	15.8	17.1	18.5	19.5	20.6	21.6	22.6	24.5	26.9
*50	13.4	14.4	15.4	16.3	18.1	19.8	21.4	23.1	24.4	25.7	27.0	28.2	30.7	33.6
*60	16.1	17.3	18.4	19.6	21.8	23.7	25.7	27.7	29.3	30.8	32.4	33.9	36.8	40.3
*80	21.5	23.0	24.6	26.1	29.0	31.7	34.3	36.9	39.0	41.1	43.1	45.1	49.0	53.8
*100	26.9	28.8	30.7	32.6	36.3	39.6	42.9	46.1	48.8	51.4	53.9	56.4	61.3	67.2
*150	40.3	43.2	46.1	48.9	54.4	59.3	64.2	69.2	73.1	77.0	80.8	84.5	91.7	100.5
*200	53.7	57.5	61.4	65.2	72.4	79.0	85.6	92.1	97.4	102.5	107.5	112.4	122.1	133.7
*300	77.9	83.3	88.8	94.4	105.9	117.7	125.5	133.0	140.3	147.5	154.5	161.4	174.8	190.7
*400	98.0	104.7	111.6	118.5	132.8	147.4	156.9	165.9	174.8	183.4	191.8	200.0	215.7	234.2
*500	116.8	124.7	132.8	140.9	157.6	174.7	185.6	196.0	206.0	215.8	225.2	234.3	251.6	271.4
*600	134.5	143.5	152.6	161.8	180.7	199.9	212.0	223.4	234.3	244.8	254.9	264.5	282.5	302.4
730	155.9	166.1	176.5	187.0	208.3	229.9	243.0	255.3	266.9	277.9	288.2	297.9	315.2	333.1
800	166.8	177.6	188.5	199.6	222.0	244.7	258.3	270.8	282.5	293.5	303.7	313.1	329.3	344.9
870	177.2	188.6	200.1	211.7	235.1	258.7	272.5	285.1	296.8	307.6	317.4	326.2	340.8	353.3
970	191.4	203.5	215.6	227.9	252.5	277.2	291.1	303.5	314.8	324.9	333.7	341.3	352.6	362.6
1170	217.3	230.4	243.6	256.7	283.0	308.8	321.9	332.9	342.0	349.3	354.6	358.0	358.4	358.4
+1200	220.9	234.1	247.4	260.6	287.0	313.0	325.8	336.4	345.0	351.7	356.3	358.8	357.1	357.1
+1460	248.9	262.8	276.5	290.0	316.5	341.6	350.8	356.6	359.2	358.6	354.4			
+1600	261.6	275.5	289.1	302.4	327.9	351.6	357.6	359.4	357.2					
+1750	273.4	287.0	300.2	312.9	336.7	357.7	359.4	355.8						
+2000	288.5	301.0	312.6	323.5	342.4	357.0								

20M PowerGrip GT2 Power Rating Table — 170mm Belt Width

RPM of Faster Shaft	Base Rated Horsepower For Small Sprocket (Number of Grooves and Pitch Diameter, Inches)													
	34 8.522	36 9.023	38 9.524	40 10.026	44 11.028	48 12.031	52 13.033	56 14.036	60 15.038	64 16.041	68 17.043	72 18.046	80 20.051	90 22.557
*10	4.2	4.5	4.8	5.1	5.6	6.1	6.7	7.2	7.6	8.0	8.4	8.8	9.5	10.4
*20	8.3	8.9	9.5	10.1	11.3	12.3	13.3	14.3	15.2	16.0	16.8	17.5	19.0	20.9
*30	12.5	13.4	14.3	15.2	16.9	18.4	20.0	21.5	22.7	23.9	25.1	26.3	28.6	31.3
*40	16.7	17.9	19.1	20.3	22.5	24.6	26.6	28.7	30.3	31.9	33.5	35.1	38.1	41.8
*50	20.9	22.4	23.9	25.3	28.2	30.7	33.3	35.8	37.9	39.9	41.9	43.8	47.6	52.2
*60	25.0	26.8	28.6	30.4	33.8	36.9	39.9	43.0	45.5	47.9	50.2	52.6	57.1	62.6
*80	33.4	35.8	38.2	40.5	45.0	49.2	53.2	57.3	60.6	63.8	67.0	70.1	76.1	83.5
*100	41.7	44.7	47.7	50.6	56.3	61.4	66.5	71.6	75.8	79.8	83.7	87.6	95.1	104.3
*150	62.5	67.0	71.5	75.9	84.4	92.1	99.8	107.4	113.6	119.5	125.4	131.2	142.5	156.1
*200	83.4	89.4	95.3	101.2	112.5	122.7	132.9	143.1	151.3	159.2	167.0	174.6	189.6	207.6
*300	120.9	129.3	137.8	146.6	164.4	182.8	194.9	206.5	217.9	229.1	240.0	250.7	271.5	296.4
*400	152.3	162.7	173.3	184.1	206.3	229.0	243.7	257.8	271.6	285.0	298.1	310.8	335.4	364.3
*500	181.5	193.8	206.3	218.9	244.9	271.5	288.4	304.6	320.2	335.4	350.1	364.3	391.3	422.5
*600	208.9	222.9	237.1	251.4	280.8	310.7	329.5	347.3	364.4	380.8	396.6	411.7	439.9	471.3
730	242.3	258.2	274.3	290.6	323.8	357.5	378.0	397.2	415.4	432.7	448.9	464.2	491.7	520.3
800	259.2	276.1	293.1	310.3	345.3	380.7	401.9	421.5	440.0	457.3	473.4	488.2	514.3	539.7
870	275.5	293.2	311.1	329.1	365.7	402.6	424.2	444.0	462.5	479.5	495.1	509.2	533.0	553.9
970	297.7	316.5	335.4	354.5	393.0	431.6	453.4	473.1	491.0	507.1	521.4	533.7	552.6	552.6
1170	338.1	358.6	379.2	399.8	440.9	481.6	502.3	520.0	534.9	547.0	556.3	562.5	565.6	565.6
+1200	343.8	364.5	385.2	405.9	447.3	488.1	508.6	525.7	539.9	551.2	559.4	564.3	564.3	564.3
+1460	387.9	409.7	431.3	452.6	494.4	534.3	549.6	559.8	565.2	565.8	561.2			
+1600	408.1	430.0	451.5	472.5	513.1	551.0	561.7	566.1	564.5					
+1750	426.9	448.4	469.4	489.6	527.8	562.1	566.4	562.9						
+2000	451.5	471.5	490.3	508.0	539.3	564.2								

Shaded area indicates drive conditions where reduced service life can be expected.

* Refer to Page 15 for additional Service Factors for speeds of 600 rpm or less.

+ Drives within this speed range may generate an objectionable noise level. This can be reduced by using commercially available acoustical damping material in the belt guard. Contact Gates for recommendations on any drive to be installed in a noise sensitive area.

$$\text{Corrected Horsepower Rating} = [\text{Base Rating}] \times [\text{Belt Length Correction Factor}]$$

20M PowerGrip® GT² Power Rating Table — 230mm Belt Width

RPM of Faster Shaft	Base Rated Horsepower For Small Sprocket (Number of Grooves and Pitch Diameter, Inches)											
	38 9.524	40 10.026	44 11.028	48 12.031	52 13.033	56 14.036	60 15.038	64 16.041	68 17.043	72 18.046	80 20.051	90 22.557
*10	6.6	7.0	7.8	8.5	9.2	10.0	10.5	11.1	11.6	12.2	13.2	14.5
*20	13.2	14.1	15.6	17.1	18.5	19.9	21.1	22.2	23.3	24.3	26.4	29.0
*30	19.9	21.1	23.5	25.6	27.7	29.9	31.6	33.2	34.9	36.5	39.7	43.5
*40	26.5	28.1	31.3	34.1	37.0	39.8	42.1	44.3	46.5	48.7	52.9	58.0
*50	33.1	35.2	39.1	42.7	46.2	49.8	52.6	55.4	58.1	60.8	66.1	72.5
*60	39.7	42.2	46.9	51.2	55.5	59.7	63.1	66.5	69.8	73.0	79.3	87.0
*80	53.0	56.3	62.5	68.2	73.9	79.6	84.2	88.6	93.0	97.3	105.7	115.9
*100	66.2	70.3	78.2	85.3	92.4	99.5	105.2	110.8	116.2	121.6	132.1	144.8
*150	99.3	105.4	117.2	127.9	138.5	149.1	157.7	166.0	174.1	182.2	197.8	216.8
*200	132.3	140.5	156.2	170.4	184.5	198.6	210.0	221.0	231.9	242.5	263.3	288.3
*300	191.4	203.5	228.3	253.9	270.6	286.8	302.6	318.1	333.3	348.2	377.1	411.7
*400	240.7	255.7	286.4	318.0	338.4	358.0	377.2	395.8	414.0	431.7	465.9	506.1
*500	286.4	304.0	340.1	377.0	400.5	423.0	444.8	466.0	486.4	506.2	543.8	587.3
*600	329.2	349.2	390.0	431.6	457.7	482.5	506.3	529.2	551.2	572.2	611.6	655.6
730	381.0	403.7	449.8	496.6	525.2	552.0	577.4	601.5	624.3	645.6	684.3	724.6
800	407.2	431.1	479.7	529.0	558.5	585.9	611.7	635.9	658.5	679.4	716.1	752.2
870	432.2	457.3	508.2	559.5	589.7	617.4	643.2	667.1	689.0	708.9	742.6	772.8
970	466.1	492.6	546.2	600.0	630.5	658.1	683.3	705.9	726.1	743.7	770.9	
+1170	527.1	555.8	613.2	670.0	699.2	724.1	745.4	762.8	776.2	785.6	791.6	
+1200	535.6	564.5	622.2	679.2	708.0	732.2	752.6	768.8	780.8	788.5	790.3	
+1460	600.1	630.0	688.5	744.5	766.4	781.4	790.0	791.9	786.8			
+1600	628.6	658.1	715.1	768.5	784.3	791.6	790.7					
+1750	654.0	682.5	736.4	785.0	792.3	788.8						
+2000	684.2	709.3	754.1	790.2								

20M PowerGrip GT2 Power Rating Table — 290mm Belt Width

RPM of Faster Shaft	Base Rated Horsepower For Small Sprocket (Number of Grooves and Pitch Diameter, Inches)							
	52 13.033	56 14.036	60 15.038	64 16.041	68 17.043	72 18.046	80 20.051	90 22.557
*10	11.8	12.7	13.5	14.2	14.9	15.6	16.9	18.6
*20	23.7	25.5	26.9	28.4	29.8	31.1	33.8	37.1
*30	35.5	38.2	40.4	42.5	44.6	46.7	50.8	55.7
*40	47.3	50.9	53.9	56.7	59.5	62.3	67.7	74.2
*50	59.1	63.7	67.3	70.9	74.4	77.8	84.6	92.8
*60	71.0	76.4	80.8	85.1	89.3	93.4	101.5	111.3
*80	94.6	101.9	107.7	113.4	119.0	124.5	135.3	148.3
*100	118.2	127.3	134.6	141.7	148.7	155.6	169.0	185.3
*150	177.3	190.8	201.8	212.4	222.9	233.1	253.2	277.5
*200	236.2	254.2	268.8	282.9	296.7	310.4	336.9	369.0
*300	346.3	367.0	387.3	407.1	426.6	445.6	482.6	527.0
*400	433.1	458.2	482.8	506.7	529.9	552.7	596.4	648.0
*500	512.7	541.5	569.4	596.5	622.7	648.1	696.3	752.1
*600	585.9	617.6	648.2	677.5	705.7	732.7	783.3	839.9
730	672.4	706.8	739.4	770.4	799.6	827.1	876.8	928.9
800	715.1	750.3	783.5	814.6	843.6	870.5	917.9	964.7
870	755.1	790.8	823.9	854.7	882.9	908.6	952.2	991.6
+970	807.6	843.1	875.5	904.8	930.8	953.7	989.2	
+1170	896.1	928.3	955.8	978.5	996.2	1008.7	1017.6	
+1200	907.4	938.8	965.2	986.4	1002.3	1012.7	1016.4	
+1460	983.3	1003.1	1014.8	1018.0	1012.4			
+1600	1007.0	1017.0	1016.8					
+1750	1018.1	1014.8						

Shaded area indicates drive conditions where reduced service life can be expected.

* Refer to Page 15 for additional Service Factors for speeds of 600 rpm or less.

+ Drives within this speed range may generate an objectionable noise level. This can be reduced by using commercially available acoustical damping material in the belt guard. Contact Gates for recommendations on any drive to be installed in a noise sensitive area.

$$\text{Corrected Horsepower Rating} = [\text{Base Rating}] \times [\text{Belt Length Correction Factor}]$$

PowerGrip® GT² Belt Length Correction Factors

Pitch/Length Designation	No. of Teeth	Correction Factor	Pitch/Length Designation	No. of Teeth	Correction Factor	Pitch/Length Designation	No. of Teeth	Correction Factor	Pitch/Length Designation	No. of Teeth	Correction Factor
2000-20M	100	0.80	4200-20M	210	1.00	5400-20M	270	1.05	6200-20M	310	1.10
2500-20M	125	0.85	4600-20M	230	1.00	5600-20M	280	1.05	6400-20M	320	1.10
3400-20M	170	0.95	5000-20M	250	1.05	5800-20M	290	1.10	6600-20M	330	1.10
3800-20M	190	1.00	5200-20M	260	1.05	6000-20M	300	1.10			



20M PowerGrip® GT®2 Power Rating Table — 340mm Belt Width

RPM of Faster Shaft	Base Rated Horsepower For Small Sprocket (Number of Grooves and Pitch Diameter, Inches)							
	52 13.033	56 14.036	60 15.038	64 16.041	68 17.043	72 18.046	80 20.051	90 22.557
*10	14.0	15.1	15.9	16.8	17.6	18.4	20.0	21.9
*20	28.0	30.1	31.9	33.5	35.2	36.8	40.0	43.9
*30	41.9	45.2	47.8	50.3	52.8	55.2	60.0	65.8
*40	55.9	60.2	63.7	67.1	70.4	73.6	80.0	87.7
*50	69.9	75.3	79.6	83.8	88.0	92.0	100.0	109.7
*60	83.9	90.3	95.5	100.6	105.5	110.4	120.0	131.6
*80	111.8	120.4	127.4	134.1	140.7	147.2	159.9	175.4
*100	139.8	150.5	159.2	167.6	175.8	183.9	199.8	219.1
*150	209.5	225.6	238.6	251.1	263.5	275.6	299.3	328.0
*200	279.2	300.5	317.8	334.4	350.8	366.9	398.3	436.3
*300	409.4	433.9	457.8	481.3	504.3	526.8	570.6	623.0
*400	512.0	541.8	570.8	599.0	626.6	653.4	705.1	766.2
*500	606.1	640.2	673.3	705.3	736.3	766.3	823.4	889.5
+*600	692.8	730.3	766.4	801.2	834.5	866.5	926.3	993.4
+730	795.1	835.8	874.4	911.1	945.7	978.3	1037.3	1099.2
+800	845.7	887.3	926.6	963.4	997.8	1029.8	1086.0	1141.8
+870	893.0	935.2	974.5	1011.0	1044.5	1075.0	1126.9	1174.0
+970	955.2	997.3	1035.7	1070.4	1101.4	1128.6	1171.1	
+1170	1060.1	1098.4	1131.2	1158.3	1179.5	1194.6	1206.0	
+1200	1073.5	1110.9	1142.4	1167.8	1186.9	1199.6	1204.7	
+1460	1164.0	1187.8	1202.1	1206.4	1200.4			
+1600	1192.5	1204.9	1205.3					
+1750	1206.4	1203.1						

* Refer to Page 15 for additional Service Factors for speeds of 600 rpm or less.

+ Drives within this speed range may generate an objectionable noise level. This can be reduced by using commercially available acoustical damping material in the belt guard. Contact Gates for recommendations on any drive to be installed in a noise sensitive area.

$$\text{Corrected Horsepower Rating} = [\text{Base Rating}] \times [\text{Belt Length Correction Factor}]$$

PowerGrip® GT®2 Belt Length Correction Factors

Pitch/Length Designation	No. of Teeth	Correction Factor	Pitch/Length Designation	No. of Teeth	Correction Factor	Pitch/Length Designation	No. of Teeth	Correction Factor	Pitch/Length Designation	No. of Teeth	Correction Factor
2000-20M	100	0.80	4200-20M	210	1.00	5400-20M	270	1.05	6200-20M	310	1.10
2500-20M	125	0.85	4600-20M	230	1.00	5600-20M	280	1.05	6400-20M	320	1.10
3400-20M	170	0.95	5000-20M	250	1.05	5800-20M	290	1.10	6600-20M	330	1.10
3800-20M	190	1.00	5200-20M	260	1.05	6000-20M	300	1.10			

PowerGrip® Timing Belt Drives

PowerGrip Timing Belt drives operate with the molded teeth of the belt designed to make positive engagement with the matching grooves on the pulleys. Gates PowerGrip belts have helically-wound fiberglass tension members embedded in a Neoprene body with the belt teeth faced with a tough wear-resistant nylon fabric.

The three principal dimensions, in inches, shown below, are used to specify a Timing belt.

330	XL	025
33.0∅ pitch length	.200∅ pitch	.25∅ wide

Belt pitch is the distance in inches between two adjacent tooth centers as measured on the pitch line of the belt. Belt pitch length is the total length (circumference) in inches as measured along the pitch line. The theoretical pitch line of a Timing belt lies within the tensile member.

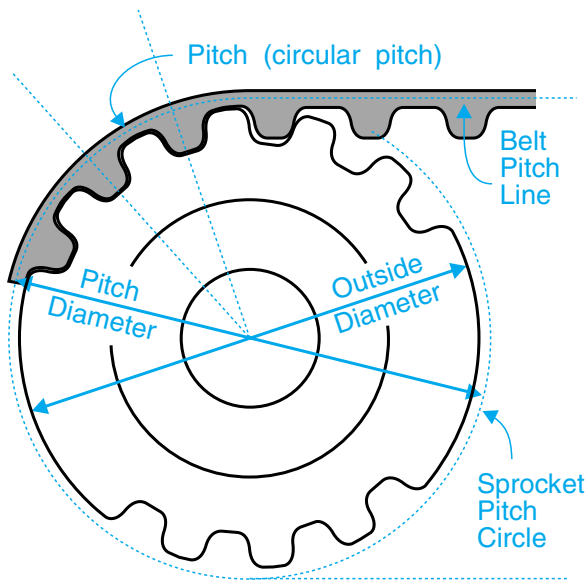

The three principal dimensions used to specify a pulley number of grooves, pitch and belt width in inches are shown below.

20	XL	025
Number of grooves	Pitch	Belt Width (1/4∅)

XL Pitch (.200) – Reference Dimensions

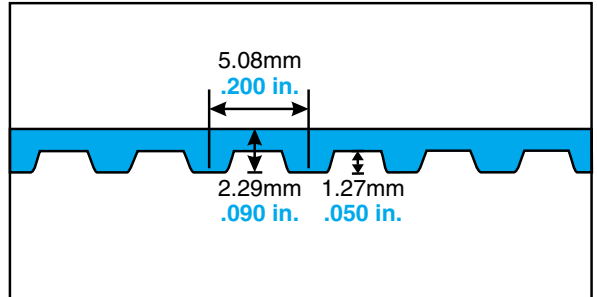

L Pitch (.375") – Reference Dimensions

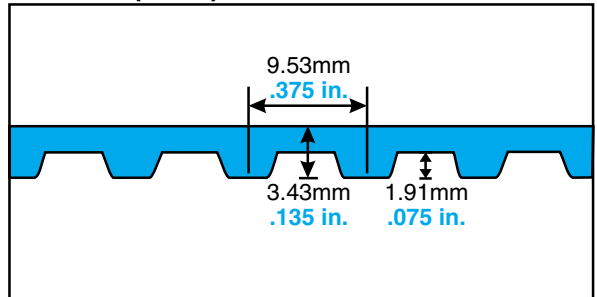

H Pitch (.500") – Reference Dimensions

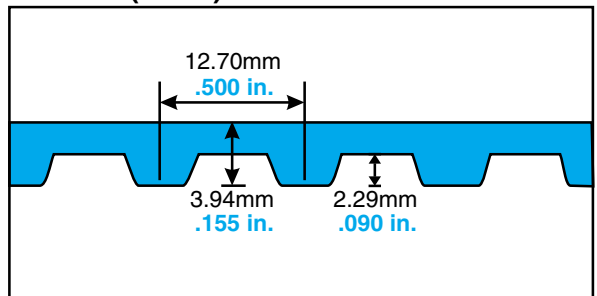

Gates PowerGrip® Timing Belts

Stock Belts

0.200" pitch extra light (XL)

Available in
 $\frac{1}{4}$ " and $\frac{3}{8}$ " widths

Length and Pitch Designation	Pitch Length (in)	Number of Teeth
50XL	5.0	25
60XL	6.0	30
70XL	7.0	35
80XL	8.0	40
90XL	9.0	45
100XL	10.0	50
110XL	11.0	55
120XL	12.0	60
130XL	13.0	65
140XL	14.0	70
150XL	15.0	75
160XL	16.0	80
170XL	17.0	85
180XL	18.0	90
190XL	19.0	95
200XL	20.0	100
210XL	21.0	105
220XL	22.0	110
230XL	23.0	115
240XL	24.0	120
250XL	25.0	125
260XL	26.0	130
280XL	28.0	140
290XL	29.0	145
300XL	30.0	150
310XL	31.0	155
330XL	33.0	165
340XL	34.0	170
350XL	35.0	175
370XL	37.0	185
380XL	38.0	190
390XL	39.0	195
400XL	40.0	200
420XL	42.0	210
450XL	45.0	225
460XL	46.0	230
480XL	48.0	240
500XL	50.0	250
570XL	57.0	285
630XL	63.0	315
770XL	77.0	385

0.375" pitch light (L)

Available in
 $\frac{1}{2}$ ", $\frac{3}{4}$ " and 1" widths

Length and Pitch Designation	Pitch Length (in)	Number of Teeth
124L	12.375	33
135L	12.5	36
150L	15.0	40
165L	16.5	44
187L	18.75	50
195L	19.50	52
210L	21.0	56
225L	22.5	60
240L	24.0	64
255L	25.5	68
270L	27.0	72
285L	28.5	76
300L	30.0	80
315L	31.5	84
322L	32.25	86
345L	34.5	92
367L	36.75	98
390L	39.0	104
420L	42.0	112
450L	45.0	120
480L	48.0	128
510L	51.0	136
540L	54.0	144
600L	60.0	160
660L	66.0	176
817L	81.75	218
900L	90.0	240

0.500" pitch heavy (H)

Available in
 $\frac{3}{4}$ ", 1", 1 $\frac{1}{2}$ " 2" and 3" widths

Length and Pitch Designation	Pitch Length (in)	Number of Teeth
210H	21.0	42
220H	22.0	44
230H	23.0	46
240H	24.0	48
270H	27.0	54
300H	30.0	60
320H	32.0	64
330H	33.0	66
340H	34.0	68
350H	35.0	70
360H	36.0	72
370H	37.0	74
390H	39.0	78
400H	40.0	80
410H	41.0	82
420H	42.0	84
450H	45.0	90
480H	48.0	96
490H	49.0	98
510H	51.0	102
540H	54.0	108
560H	56.0	112
570H	57.0	114
585H	58.5	117
600H	60.0	120
630H	63.0	126
645H	64.5	129
660H	66.0	132
700H	70.0	140
730H	73.0	146
750H	75.0	150
780H	78.0	156
800H	80.0	160
820H	82.0	164
840H	84.0	168
850H	85.0	170
900H	90.9	180
960H	96.0	192
1000H	100.0	200
1100H	110.0	220
1140H	114.0	228
1250H	125.0	250
1400H	140.0	280
1550H	155.0	310
1700H	170.0	340

NOTE: Belt lengths other than those shown may be available as a made-to-order item. Contact your local Gates representative for details.

XL, 0.200" Pitch Belts

Drive Selection Table

DriveN Speed		Sprocket Combinations				Speed Ratio	Center Distance, Inches																																
For motor speed of		DriveR		DriveN																																			
1160 RPM	1750 RPM	3450 RPM	No. of grooves	Pitch diam. inches	No. of grooves		Pitch diam. inches	60XL P.L. 6.00 30 Teeth	70XL P.L. 7.00 35 Teeth	80XL P.L. 8.00 40 Teeth	90XL P.L. 9.00 45 Teeth	100XL P.L. 10.00 50 Teeth	110XL P.L. 11.00 55 Teeth	120XL P.L. 12.00 60 Teeth	130XL P.L. 13.00 65 Teeth	140XL P.L. 14.00 70 Teeth	150XL P.L. 15.00 75 Teeth	160XL P.L. 16.00 80 Teeth	170XL P.L. 17.00 85 Teeth	180XL P.L. 18.00 90 Teeth	190XL P.L. 19.00 95 Teeth	200XL P.L. 20.00 100 Teeth	210XL P.L. 21.00 105 Teeth	220XL P.L. 22.00 110 Teeth	230XL P.L. 23.00 115 Teeth	240XL P.L. 24.00 120 Teeth	250XL P.L. 25.00 125 Teeth	260XL P.L. 26.00 130 Teeth											
422	636	1255	16	1.019	44	2.801					2.33	2.86	3.38	3.90	4.41	4.92	5.43	5.93	6.44	6.94	7.45	7.95	8.45	8.96	9.46	9.96													
414	625	1232	10	0.637	28	1.783					2.02	2.53	3.05	3.55	4.06	4.56	5.07	5.57	6.07	6.57	7.08	7.58	8.08	8.58	9.08	9.58	10.08	10.58	11.08										
414	625	1232	15	0.955	42	2.674								2.50	3.03	3.55	4.06	4.57	5.08	5.58	6.09	6.59	7.10	7.60	8.10	8.61	9.11	9.61	10.11										
406	613	1208	14	0.891	40	2.546								2.14	2.67	3.19	3.71	4.22	4.73	5.24	5.74	6.25	6.75	7.25	7.76	8.26	8.76	9.26	9.77	10.27									
406	613	1208	21	1.337	60	3.820												3.21	3.74	4.27	4.79	5.30	5.82	6.33	6.84	7.34	7.85	8.36	8.86										
399	602	1186	11	0.700	32	2.037												5.31	5.81	6.31	6.82	7.32	7.82	8.32	8.83	9.33	9.83	10.33	10.83										
395	597	1176	15	0.955	44	2.801												4.45	4.96	5.47	5.98	6.48	6.99	7.49	8.00	8.50	9.00	9.51	10.01										
387	583	1150	10	0.637	30	1.910												5.46	5.97	6.47	6.97	7.47	7.97	8.48	8.98	9.48	9.98	10.48	10.98										
387	583	1150	12	0.764	36	2.292												5.04	5.55	6.05	6.56	7.06	7.56	8.06	8.57	9.07	9.57	10.07	10.57										
387	583	1150	14	0.891	42	2.674												4.61	5.12	5.63	6.14	6.64	7.14	7.65	8.15	8.65	9.16	9.66	10.16										
387	583	1150	16	1.019	48	3.056												4.17	4.69	5.20	5.71	6.22	6.72	7.23	7.73	8.24	8.74	9.24	9.75	10.25									
387	583	1150	20	1.273	60	3.820												3.25	3.78	4.31	4.83	5.35	5.86	6.37	6.88	7.39	7.90	8.40	8.91	9.41									
387	583	1150	24	1.528	72	4.584														3.34	3.90	4.43	4.96	5.49	6.00	6.52	7.03	7.54	8.05	8.55									
369	557	1098	14	0.891	44	2.801												4.50	5.01	5.52	6.02	6.53	7.04	7.54	8.04	8.55	9.05	9.55	10.05										
363	547	1078	10	0.637	32	2.037												5.35	5.86	6.36	6.86	7.37	7.87	8.37	8.87	9.37	9.88	10.38	10.88										
363	547	1078	15	0.955	48	3.056												4.22	4.73	5.24	5.75	6.26	6.77	7.27	7.78	8.28	8.79	9.29	9.79	10.29									
354	535	1054	11	0.700	36	2.292												3.33	3.84	4.34	4.85	5.35	5.86	6.36	6.87	7.37	7.88	8.38	8.89	9.39									
354	535	1054	22	1.401	72	4.584												2.64	3.17	3.70	4.22	4.73	5.24	5.75	6.26	6.77	7.27	7.78	8.28	8.79	9.29								
348	525	1035	12	0.764	40	2.546												3.33	3.87	4.39	4.92	5.43	5.95	6.46	6.97	7.48	7.99	8.49	9.00	9.50									
348	525	1035	18	1.146	60	3.820														2.77	3.33	3.87	4.39	4.92	5.43	5.95	6.46	6.97	7.48	7.99	8.49	9.00							
338	510	1006	14	0.891	48	3.056												2.68	3.22	3.74	4.26	4.78	5.29	5.80	6.31	6.81	7.32	7.83	8.33	8.83	9.34	9.84							
338	510	1006	21	1.337	72	4.584												3.22	3.74	4.26	4.78	5.29	5.80	6.31	6.81	7.32	7.83	8.33	8.83	9.34	9.84								
331	500	986	12	0.764	42	2.674												3.15	3.68	4.19	4.70	5.21	5.72	6.23	6.73	7.24	7.74	8.24	8.75	9.25	9.75	10.26							
322	486	958	10	0.637	36	2.292												2.08	2.62	3.09	3.60	4.12	4.63	5.13	5.64	6.14	6.65	7.15	7.65	8.16	8.66	9.16	9.67						
322	486	958	20	1.273	72	4.584												2.03	2.56	3.09	3.60	4.12	4.63	5.13	5.64	6.14	6.65	7.15	7.65	8.16	8.66	9.16	9.67						
319	481	949	11	0.700	40	2.546														2.26	2.80	3.32	3.84	4.35	4.86	5.37	5.88	6.38	6.89	7.39	7.90	8.40	8.90	9.41					
316	477	941	12	0.764	44	2.801														2.49	3.03	3.55	4.07	4.59	5.10	5.61	6.12	6.62	7.13	7.63	8.14	8.64	9.14	9.65	10.15				
309	467	920	16	1.019	60	3.820														2.85	3.41	3.95	4.48	5.00	5.52	6.04	6.55	7.06	7.57	8.08	8.58	9.09	9.59	10.09					
304	458	904	11	0.700	42	2.674														2.12	2.67	3.20	3.72	4.23	4.75	5.26	5.77	6.27	6.78	7.28	7.79	8.29	8.79	9.30	9.80	10.30			
290	438	863	10	0.637	40	2.546														2.30	2.84	3.36	3.88	4.40	4.91	5.42	5.92	6.43	6.93	7.44	7.94	8.45	8.95	9.45	9.95	10.46			
290	438	863	11	0.700	44	2.801														1.96	2.53	3.07	3.60	4.12	4.63	5.14	5.65	6.16	6.67	7.17	7.68	8.18	8.69	9.19	9.69	10.20			
290	438	863	12	0.764	48	3.056															2.19	2.76	3.30	3.83	4.35	4.86	5.38	5.89	6.40	6.90	7.41	7.92	8.42	8.93	9.43	9.93			
290	438	863	15	0.955	60	3.820																																	
290	438	863	18	1.146	72	4.584																																	
276	417	821	10	0.637	42	2.674																																	
271	408	805	14	0.891	60	3.820																																	
266	401	791	11	0.700	48	3.056																																	
264	398	784	10	0.637	44	2.801																																	
258	389	767	16	1.019	72	4.584																																	
242	365	719	10	0.637	48	3.056																																	
242	365	719	15	0.955	72	4.584																																	
232	350	690	12	0.764	60	3.820																																	
226	340	671	14	0.891	72	4.584																																	
213	321	633	11	0.700	60	3.820																																	
193	292	575	10	0.637	60	3.820																																	
193	292	575	12	0.764	72	4.584																																	
177	267	527	11	0.700	72	4.584																																	
161	243	479	10	0.637	72	4.584																																	

Key to Horsepower Correction Factor □ =1.0 □ =0.8 □ =0.6 □ =0.4 □ =0.2



The Gates Rubber Company

L, 0.375" Pitch Belts

Drive Selection Table

DriveN Speed			Sprocket Combinations				Center Distance, Inches																					
For motor speed of			DriveR		DriveN		Speed Ratio	124L	150L	187L	210L	225L	240L	255L	270L	285L	300L	322L	345L	367L	390L	420L	450L	480L	510L	540L	600L	
1160 RPM	1750 RPM	3450 RPM	No. of grooves	Pitch diam. inches	No. of grooves	Pitch diam. inches		P.L. 12.375 33 Teeth	P.L. 15.00 40 Teeth	P.L. 18.75 50 Teeth	P.L. 21.00 56 Teeth	P.L. 22.50 60 Teeth	P.L. 24.00 64 Teeth	P.L. 25.50 68 Teeth	P.L. 27.00 72 Teeth	P.L. 28.50 76 Teeth	P.L. 30.00 80 Teeth	P.L. 32.25 86 Teeth	P.L. 34.50 92 Teeth	P.L. 36.75 98 Teeth	P.L. 39.00 104 Teeth	P.L. 42.00 112 Teeth	P.L. 45.00 120 Teeth	P.L. 48.00 128 Teeth	P.L. 51.00 136 Teeth	P.L. 54.00 144 Teeth	P.L. 60.00 160 Teeth	
1160	1750	3450	10	1.194	10	1.194	1.000	4.31	5.62	7.50	8.62	9.37	10.12	10.87	11.62	12.37	13.12	14.25	15.37	16.50	17.62	19.12	20.62	22.12	23.62	25.12	28.12	
1160	1750	3450	12	1.432	12	1.432	1.000	3.94	5.25	7.13	8.25	9.00	9.75	10.50	11.25	12.00	12.75	13.88	15.00	16.13	17.25	18.75	20.25	21.75	23.25	24.75	27.75	
1160	1750	3450	14	1.671	14	1.671	1.000	3.56	4.88	6.75	7.88	8.63	9.38	10.13	10.88	11.63	12.38	13.50	14.63	15.75	16.88	18.38	19.88	21.38	22.88	24.38	27.38	
1160	1750	3450	16	1.910	16	1.910	1.000	3.19	4.50	6.37	7.50	8.25	9.00	9.75	10.50	11.25	12.00	13.12	14.25	15.37	16.50	18.00	19.50	21.00	22.50	24.00	27.00	
1160	1750	3450	17	2.029	17	2.029	1.000	3.00	4.31	6.19	7.31	8.06	8.81	9.56	10.31	11.06	11.81	12.94	14.06	15.19	16.31	17.81	19.31	20.81	22.31	23.81	26.81	
1160	1750	3450	18	2.149	18	2.149	1.000	2.81	4.12	6.00	7.12	7.87	8.62	9.37	10.12	10.87	11.62	12.75	13.87	15.00	16.12	17.62	19.12	20.62	22.12	23.62	26.62	
1160	1750	3450	19	2.268	19	2.268	1.000	2.62	3.94	5.81	6.94	7.69	8.44	9.19	9.94	10.69	11.44	12.56	13.69	14.81	15.94	17.44	18.94	20.44	21.94	23.44	26.44	
1160	1750	3450	20	2.387	20	2.387	1.000		3.75	5.63	6.75	7.50	8.25	9.00	9.75	10.50	11.25	12.38	13.50	14.63	15.75	17.25	18.75	20.25	21.75	23.25	26.25	
1160	1750	3450	21	2.507	21	2.507	1.000		3.56	5.44	6.56	7.31	8.06	8.81	9.56	10.31	11.06	12.19	13.31	14.44	15.56	17.06	18.56	20.06	21.56	23.06	26.06	
1160	1750	3450	22	2.626	22	2.626	1.000		3.38	5.25	6.38	7.13	7.88	8.63	9.38	10.13	10.88	12.00	13.13	14.25	15.38	16.88	18.38	19.88	21.38	22.88	25.88	
1160	1750	3450	24	2.865	24	2.865	1.000			4.87	6.00	6.75	7.50	8.25	9.00	9.75	10.50	11.62	12.75	13.87	15.00	16.50	18.00	19.50	21.00	22.50	25.50	
1160	1750	3450	26	3.104	26	3.104	1.000			4.50	5.62	6.37	7.12	7.87	8.62	9.37	10.12	11.25	12.37	13.50	14.62	16.12	17.62	19.12	20.62	22.12	25.12	
1160	1750	3450	28	3.342	28	3.342	1.000				4.13	5.25	6.00	6.75	7.50	8.25	9.00	9.75	10.88	12.00	13.13	14.25	15.75	17.25	18.75	20.25	21.75	24.75
1160	1750	3450	30	3.581	30	3.581	1.000					4.87	5.62	6.37	7.12	7.87	8.62	9.37	10.50	11.62	12.75	13.87	15.37	16.87	18.37	19.87	21.37	24.37
1160	1750	3450	32	3.820	32	3.820	1.000					4.50	5.25	6.00	6.75	7.50	8.25	9.00	10.12	11.25	12.37	13.50	15.00	16.50	18.00	19.50	21.00	24.00
1160	1750	3450	36	4.297	36	4.297	1.000						5.25	6.00	6.75	7.50	8.25	9.38	10.50	11.63	12.75	14.25	15.75	17.25	18.75	20.25	23.25	
1160	1750	3450	40	4.775	40	4.775	1.000							5.25	6.00	6.75	7.50	8.62	9.75	10.87	12.00	13.50	15.00	16.50	18.00	19.50	22.50	
1160	1750	3450	44	5.252	44	5.252	1.000								6.00	6.75	7.50	8.62	9.75	10.87	12.00	13.50	15.00	16.50	18.00	19.50	22.50	
1160	1750	3450	48	5.730	48	5.730	1.000									6.75	7.50	8.62	9.75	10.87	12.00	13.50	15.00	16.50	18.00	19.50	22.50	
1107	1670	3293	21	2.507	22	2.626	1.048																					
1105	1667	3286	20	2.387	21	2.507	1.050																					
1102	1663	3278	19	2.268	20	2.387	1.053																					
1099	1658	3268	18	2.149	19	2.268	1.056																					
1096	1653	3258	17	2.029	18	2.149	1.059	2.72	4.03	5.91	7.03	7.78	8.53	9.28	10.03	10.78	11.53	12.66	13.78	14.91	16.03	17.53	19.03	20.53	22.03	23.53	26.53	
1092	1647	3247	16	1.910	17	2.029	1.063	2.91	4.22	6.09	7.22	7.97	8.72	9.47	10.22	10.97	11.72	12.84	13.97	15.09	16.22	17.72	19.22	20.72	22.22	23.72	26.72	
1088	1641	3234	30	3.581	32	3.820	1.067	3.09	4.41	6.28	7.41	8.16	8.91	9.66	10.41	11.16	11.91	13.03	14.16	15.28	16.41	17.91	19.41	20.91	22.41	23.91	26.91	
1083	1633	3220	28	3.342	30	3.581	1.071																					
1077	1625	3204	26	3.104	28	3.342	1.077																					
1071	1615	3185	24	2.865	26	3.104	1.083																					
1063	1604	3163	22	2.626	24	2.865	1.091																					
1063	1604	3163	44	5.252	48	5.730	1.091																					
1055	1591	3136	20	2.387	22	2.626	1.100	3.19	4.69	6.56	7.69	8.44	9.19	9.94	10.69	11.44	12.19	13.31	14.44	15.56	17.06	18.56	20.06	21.56	23.06	26.06		
1055	1591	3136	40	4.775	44	5.252	1.100																					
1050	1583	3121	19	2.268	21	2.507	1.105																					
1044	1575	3105	18	2.149	20	2.387	1.111	2.62	3.75	5.62	6.75	7.50	8.25	9.00	9.75	10.50	11.25	12.37	13.50	14.62	15.75	17.25	18.75	20.25	21.75	23.25	26.25	
1044	1575	3105	36	4.297	40	4.775	1.111																					
1038	1566	3087	17	2.029	19	2.268	1.118																					
1031	1556	3067	16	1.910	18	2.149	1.125																					
1031	1556	3067	32	3.820	36	4.297	1.125																					
1015	1531	3019	14	1.671	16	1.910	1.143	3.37	4.69	6.56	7.69	8.44	9.19	9.94	10.69	11.44	12.19	13.31	14.44	15.56	16.69	18.19	19.69	21.19	22.69	24.19	27.19	
1015	1531	3019	21	2.507	24	2.865	1.143																					
1015	1531	3019	28	3.342	32	3.820	1.143																					
1005	1517	2990	26	3.104	30	3.581	1.154																					
1002	1511	2980	19	2.268	22	2.626	1.158																					
994	1500	2957	12	1.432	14	1.671	1.167																					
994	1500	2957	18	2.149	21	2.507	1.167	3.75	5.06	6.94	8.06	8.81	9.56	10.31	11.06	11.81	12.56	13.69	14.81	15.94	17.06	18.56	20.06	21.56	23.06	24.56	27.56	
994	1500	2957	24	2.865	28	3.342	1.167																					

Key to Horsepower Correction Factor =1.0 =0.8



L, 0.375" Pitch Belts

Drive Selection Table

DriveN Speed			Sprocket Combinations				Speed Ratio	Center Distance, Inches																				
For motor speed of			DriveR		DriveN			124L P.L. 12.375 33 Teeth	150L P.L. 15.00 40 Teeth	187L P.L. 18.75 50 Teeth	210L P.L. 21.00 56 Teeth	225L P.L. 22.50 60 Teeth	240L P.L. 24.00 64 Teeth	255L P.L. 25.50 68 Teeth	270L P.L. 27.00 72 Teeth	285L P.L. 28.50 76 Teeth	300L P.L. 30.00 80 Teeth	322L P.L. 32.25 86 Teeth	345L P.L. 34.50 92 Teeth	367L P.L. 36.75 98 Teeth	390L P.L. 39.00 104 Teeth	420L P.L. 42.00 112 Teeth	450L P.L. 45.00 120 Teeth	480L P.L. 48.00 128 Teeth	510L P.L. 51.00 136 Teeth	540L P.L. 54.00 144 Teeth	600L P.L. 60.00 160 Teeth	
1160 RPM	1750 RPM	3450 RPM	No. of grooves	Pitch diam. inches	No. of grooves	Pitch diam. inches																						
459	693	1366	19	2.268	48	5.730												9.69	10.83	11.97	13.10	14.62	16.13	17.63	19.14	20.65	23.66	
451	681	1342	14	1.671	36	4.297			4.49	5.66	6.43	7.19	7.95	8.71	9.47	10.23	11.36	12.49	13.62	14.75	16.26	17.76	19.27	20.77	22.27	25.28		
451	681	1342	28	3.342	72	8.594											6.18	7.40	8.60	9.77	11.32	12.86	14.39	15.91	17.43	20.46		
448	676	1333	17	2.029	44	5.252				4.49	5.28	6.07	6.84	7.61	8.38	9.14	10.28	11.42	12.55	13.69	15.20	16.70	18.21	19.72	21.22	24.23		
446	673	1327	10	1.194	26	3.104	2.64	4.01	5.92	7.06	7.82	8.57	9.33	10.08	10.83	11.58	12.71	13.84	14.97	16.10	17.60	19.10	20.60	22.10	23.61	26.61		
442	667	1314	32	3.820	84	10.027														8.02	9.62	11.19	12.74	14.29	15.82	18.87		
435	656	1294	12	1.432	32	3.820		3.15	5.11	6.26	7.02	7.78	8.54	9.30	10.05	10.81	11.94	13.07	14.20	15.33	16.83	18.34	19.84	21.34	22.84	25.85		
435	656	1294	18	2.149	48	5.730					4.72	5.52	6.31	7.08	7.86	8.63	9.77	10.91	12.05	13.19	14.70	16.21	17.72	19.23	20.73	23.74		
435	656	1294	36	4.297	96	11.459														9.44	11.04	12.61	14.17	15.72	17.25			
425	642	1265	22	2.626	60	7.162														10.44	11.59	13.12	14.64	16.15	17.67	22.20		
425	642	1265	44	5.252	120	14.324																				10.64	13.88	
422	636	1255	16	1.910	44	5.252				4.57	5.36	6.15	6.92	7.69	8.46	9.22	10.36	11.50	12.64	13.77	15.28	16.79	18.30	19.80	21.31	24.32		
419	632	1246	26	3.104	72	8.594														8.75	9.93	11.48	13.02	14.55	16.08	17.60	20.63	
414	625	1232	10	1.194	28	3.342															7.56	8.75	9.93	11.48	13.02	14.55	17.58	
414	625	1232	30	3.581	84	10.027																					14.45	19.04
411	620	1222	17	2.029	48	5.730																					23.83	
406	613	1208	14	1.671	40	4.775				4.01	5.20	5.98	6.76	7.53	8.29	9.05	9.81	10.95	12.09	13.22	14.35	15.86	17.37	18.87	20.38	21.88	24.89	
406	613	1208	21	2.507	60	7.162															9.37	10.52	11.67	13.20	14.72	16.24	17.75	22.28
387	583	1150	10	1.194	30	3.581																					21.82	
387	583	1150	12	1.432	36	4.297		3.55	5.49	6.64	7.40	8.16	8.92	9.68	10.43	11.19	12.32	13.45	14.58	15.70	17.21	18.71	20.21	21.72	23.22	26.22		
387	583	1150	16	1.910	48	5.730					4.87	5.68	6.47	7.25	8.02	8.79	9.94	11.08	12.23	13.36	14.88	16.39	17.90	19.41	20.91	23.92		
387	583	1150	20	2.387	60	7.162																					22.37	
387	583	1150	24	2.865	72	8.594																					20.80	
387	583	1150	28	3.342	84	10.027																					19.21	
387	583	1150	32	3.820	96	11.459																					17.58	
387	583	1150	40	4.775	120	14.324																					10.94	14.19
369	557	1098	14	1.671	44	5.252					4.72	5.52	6.31	7.09	7.86	8.63	9.39	10.54	11.68	12.81	13.95	15.46	16.97	18.48	19.98	21.49	24.50	
367	554	1093	19	2.268	60	7.162																					22.46	
363	547	1078	10	1.194	32	3.820		3.30	5.27	6.43	7.19	7.95	8.71	9.47	10.23	10.98	12.12	13.25	14.38	15.51	17.01	18.52	20.02	21.52	23.02	26.03		
363	547	1078	30	3.581	96	11.459																					17.75	
359	542	1068	26	3.104	84	10.027																					19.38	
354	535	1054	22	2.626	72	8.594																					20.98	
348	525	1035	12	1.432	40	4.775			4.16	5.36	6.15	6.92	7.69	8.46	9.22	9.98	11.12	12.26	13.40	14.53	16.04	17.55	19.05	20.56	22.06	25.07		
348	525	1035	18	2.149	60	7.162																					22.55	
348	525	1035	36	4.297	120	14.324																					14.50	
338	510	1006	14	1.671	48	5.730				4.18	5.02	5.83	6.62	7.41	8.18	8.96	10.11	11.25	12.40	13.53	15.05	16.56	18.07	19.58	21.09	24.10		
338	510	1006	21	2.507	72	8.594																					21.06	
338	510	1006	28	3.342	96	11.459																					17.91	
331	500	986	24	2.865	84	10.027																					19.55	
329	496	978	17	2.029	60	7.162																					22.64	
322	486	958	10	1.194	36	4.297			4.81	5.99	6.76	7.53	8.29	9.05	9.81	10.57	11.71	12.84	13.98	15.11	16.61	18.12	19.63	21.13	22.63	25.64		
322	486	958	20	2.387	72	8.594																					21.15	
316	477	941	12	1.432	44	5.252				4.87	5.68	6.47	7.25	8.02	8.79	9.56	10.70	11.85	12.98	14.12	15.63	17.14	18.65	20.16	21.67	24.68		
314	474	934	26	3.104	96	11.459																					18.08	
309	467	920	16	1.910	60	7.162																					22.72	
309	467	920	32	3.820	120	14.324																					14.81	
306	462	910	19	2.268	72	8.594																					21.23	
304	458	904	22	2.626	84	10.027																					19.71	

Key to Horsepower Correction Factor: =1.0 =0.8 =0.6 =0.4



The Driving Force in Power Transmission.

L, 0.375" Pitch Belts

Drive Selection Table

DriveN Speed			Sprocket Combinations				Speed Ratio	Center Distance, Inches																				
For motor speed of			DriveR		DriveN			124L P.L. 12.375 33 Teeth	150L P.L. 15.00 40 Teeth	187L P.L. 18.75 50 Teeth	210L P.L. 21.00 56 Teeth	225L P.L. 22.50 60 Teeth	240L P.L. 24.00 64 Teeth	255L P.L. 25.50 68 Teeth	270L P.L. 27.00 72 Teeth	285L P.L. 28.50 76 Teeth	300L P.L. 30.00 80 Teeth	322L P.L. 32.25 86 Teeth	345L P.L. 34.50 92 Teeth	367L P.L. 36.75 98 Teeth	390L P.L. 39.00 104 Teeth	420L P.L. 42.00 112 Teeth	450L P.L. 45.00 120 Teeth	480L P.L. 48.00 128 Teeth	510L P.L. 51.00 136 Teeth	540L P.L. 54.00 144 Teeth	600L P.L. 60.00 160 Teeth	
1160 RPM	1750 RPM	3450 RPM	No. of grooves	Pitch diam. inches	No. of grooves	Pitch diam. inches																						
290	438	863	10	1.194	40	4.775			4.31																			
290	438	863	12	1.432	48	5.730				4.33	5.17	5.98	6.78	7.57	8.35		10.15	11.29	12.43	13.57	14.70	16.21	17.72	19.23	20.73	22.24	25.25	
290	438	863	18	2.149	72	8.594											5.61	6.92		9.38	10.57	12.13	13.68	15.22	16.75	18.28	21.32	
290	438	863	21	2.507	84	10.027														7.58	8.84	10.47	12.07	13.63	15.19	16.73	19.80	
290	438	863	24	2.865	96	11.459																8.66	10.34	11.97	13.56	15.14	18.24	
290	438	863	30	3.581	120	14.324																9.95	11.68	13.41	15.14	16.87	19.96	
276	417	821	20	2.387	84	10.027											5.68	7.00		7.65	8.92	10.55	12.14	13.71	15.27	16.81	19.88	
274	413	815	17	2.029	72	8.594														9.46	10.65	12.21	13.76	15.30	16.84	18.36	21.40	
271	408	805	14	1.671	60	7.162							5.05	5.91	6.75	7.56	8.75	9.93										
271	408	805	28	3.342	120	14.324																						
266	401	791	22	2.626	96	11.459																						
264	398	784	10	1.194	44	5.252			3.75	5.02	5.83	6.62	7.41	8.18	8.96	9.72	10.87	12.02	13.16	14.29	15.81	17.32	18.83	20.34	21.84	24.85		
262	396	780	19	2.268	84	10.027														6.37	7.72	8.99	10.63	12.22	13.79	15.35	16.90	
258	389	767	16	1.910	72	8.594														8.32	9.53	10.73	12.29	13.84	15.39	16.92	18.45	
254	383	755	21	2.507	96	11.459																8.88	10.57	12.20	13.80	15.37	16.90	
251	379	748	26	3.104	120	14.324																						
249	375	739	18	2.149	84	10.027														6.44	7.79	9.07	10.70	12.30	13.87	15.43	16.98	
242	365	719	10	1.194	48	5.730			4.47	5.32	6.14	6.94	7.73	8.51	9.28	10.44	11.59	12.73	13.88	15.39	16.91	18.42	19.93	21.44	24.46			
242	365	719	20	2.387	96	11.459																7.13	8.95	10.64	12.28	13.88	15.45	
235	354	698	17	2.029	84	10.027														6.51	7.87	9.14	10.78	12.38	13.95	15.51	17.06	
232	350	690	12	1.432	60	7.162							5.19	6.06	6.90	7.71	8.91	10.09	11.26	12.42	13.96	15.48	17.01	18.53	20.05	23.07		
232	350	690	24	2.865	120	14.324																						
230	346	683	19	2.268	96	11.459																7.19	9.02	10.72	12.35	13.96	15.53	
226	340	671	14	1.671	72	8.594																9.14	10.78	12.38	13.95	15.51	17.06	
221	333	657	16	1.910	84	10.027																7.94	9.22	10.86	12.46	14.03	15.59	
218	328	647	18	2.149	96	11.459																7.26	9.09	10.79	12.43	14.03	15.61	
213	321	633	22	2.626	120	14.324																						
205	310	611	17	2.029	96	11.459																7.33	9.16	10.87	12.51	14.11	15.69	
203	306	604	21	2.507	120	14.324																						
193	292	575	10	1.194	60	7.162						4.37	5.33	6.20	7.05	7.86	9.07	10.25	11.42	12.58	14.12	15.65	17.18	18.70	20.22	23.25		
193	292	575	12	1.432	72	8.594										6.03	7.36	8.62	9.84	11.04	12.61	14.17	15.72	17.25	18.78	21.83		
193	292	575	14	1.671	84	10.027												6.71	8.08	9.36	11.01	12.61	14.19	15.76	17.31	20.38		
193	292	575	16	1.910	96	11.459																7.40	9.24	10.94	12.58	14.19	15.77	
193	292	575	20	2.387	120	14.324																						
184	277	546	19	2.268	120	14.324																						
174	263	518	18	2.149	120	14.324																						
169	255	503	14	1.671	96	11.459																7.53	9.38	11.09	12.74	14.34	15.93	
166	250	493	12	1.432	84	10.027																8.22	9.51	11.16	12.77	14.35	15.92	
164	248	489	17	2.029	120	14.324																						
161	243	479	10	1.194	72	8.594																						
155	233	460	16	1.910	120	14.324																						
145	219	431	12	1.432	96	11.459																						
138	208	411	10	1.194	84	10.027																						
135	204	403	14	1.671	120	14.324																						
121	182	359	10	1.194	96	11.459																						
116	175	345	12	1.432	120	14.324																						
97	146	288	10	1.194	120	14.324																						

Key to Horsepower Correction Factor =1.0 =0.8 =0.6 =0.4 =0.2

H, 0.500" Pitch Belts

Drive Selection Table

DriveN Speed				Sprocket Combinations				Center Distance, Inches																																																																																																																																																																																																																																																																																																																																																																																																																																																																																																																																																																																																																																																																																					
For motor speed of			DriveR		DriveN		Speed Ratio																																																																																																																																																																																																																																																																																																																																																																																																																																																																																																																																																																																																																																																																																						
1160 RPM	1750 RPM	3450 RPM	No. of grooves	Pitch diam. inches	No. of grooves	Pitch diam. inches		24OH P.L. 24.00 48 Teeth	27OH P.L. 27.00 54 Teeth	30OH P.L. 30.00 60 Teeth	33OH P.L. 33.00 66 Teeth	36OH P.L. 36.00 72 Teeth	39OH P.L. 39.00 78 Teeth	42OH P.L. 42.00 84 Teeth	45OH P.L. 45.00 90 Teeth	48OH P.L. 48.00 96 Teeth	51OH P.L. 51.00 102 Teeth	54OH P.L. 54.00 108 Teeth	57OH P.L. 57.00 114 Teeth	60OH P.L. 60.00 120 Teeth	63OH P.L. 63.00 126 Teeth	66OH P.L. 66.00 132 Teeth	70OH P.L. 70.00 140 Teeth	75OH P.L. 75.00 150 Teeth	80OH P.L. 80.00 160 Teeth	85OH P.L. 85.00 170 Teeth	90OH P.L. 90.00 180 Teeth	100OH P.L. 100.00 200 Teeth	110OH P.L. 110.00 220 Teeth	125OH P.L. 125.00 250 Teeth	140OH P.L. 140.00 280 Teeth	150OH P.L. 150.00 300 Teeth	170OH P.L. 170.00 340 Teeth																																																																																																																																																																																																																																																																																																																																																																																																																																																																																																																																																																																																																																																												
1160	1750	3450	14	2.228	14	2.228	1.000	8.50	10.00	11.50	13.00	14.50	16.00	17.50	19.00	20.50	22.00	23.50	25.00	26.50	28.00	29.50	31.00	32.50	34.00	35.50	37.00	38.50	40.00	41.50	43.00	44.50	46.00	47.50	49.00	50.50	52.00	53.50	55.00	56.50	58.00	59.50	61.00	62.50	64.00	65.50	67.00	68.50	70.00	71.50	73.00	74.50	76.00	77.50	79.00	80.50	82.00	83.50	85.00	86.50	88.00	89.50	91.00	92.50	94.00	95.50	97.00	98.50	100.00	101.50	103.00	104.50	106.00	107.50	109.00	110.50	112.00	113.50	115.00	116.50	118.00	119.50	121.00	122.50	124.00	125.50	127.00	128.50	130.00	131.50	133.00	134.50	136.00	137.50	139.00	140.50	142.00	143.50	145.00	146.50	148.00	149.50	151.00	152.50	154.00	155.50	157.00	158.50	160.00	161.50	163.00	164.50	166.00	167.50	169.00	170.50	172.00	173.50	175.00	176.50	178.00	179.50	181.00	182.50	184.00	185.50	187.00	188.50	190.00	191.50	193.00	194.50	196.00	197.50	199.00	200.50	202.00	203.50	205.00	206.50	208.00	209.50	211.00	212.50	214.00	215.50	217.00	218.50	220.00	221.50	223.00	224.50	226.00	227.50	229.00	230.50	232.00	233.50	235.00	236.50	238.00	239.50	241.00	242.50	244.00	245.50	247.00	248.50	250.00	251.50	253.00	254.50	256.00	257.50	259.00	260.50	262.00	263.50	265.00	266.50	268.00	269.50	271.00	272.50	274.00	275.50	277.00	278.50	280.00	281.50	283.00	284.50	286.00	287.50	289.00	290.50	292.00	293.50	295.00	296.50	298.00	299.50	301.00	302.50	304.00	305.50	307.00	308.50	310.00	311.50	313.00	314.50	316.00	317.50	319.00	320.50	322.00	323.50	325.00	326.50	328.00	329.50	331.00	332.50	334.00	335.50	337.00	338.50	340.00	341.50	343.00	344.50	346.00	347.50	349.00	350.50	352.00	353.50	355.00	356.50	358.00	359.50	361.00	362.50	364.00	365.50	367.00	368.50	370.00	371.50	373.00	374.50	376.00	377.50	379.00	380.50	382.00	383.50	385.00	386.50	388.00	389.50	391.00	392.50	394.00	395.50	397.00	398.50	400.00	401.50	403.00	404.50	406.00	407.50	409.00	410.50	412.00	413.50	415.00	416.50	418.00	419.50	421.00	422.50	424.00	425.50	427.00	428.50	430.00	431.50	433.00	434.50	436.00	437.50	439.00	440.50	442.00	443.50	445.00	446.50	448.00	449.50	451.00	452.50	454.00	455.50	457.00	458.50	460.00	461.50	463.00	464.50	466.00	467.50	469.00	470.50	472.00	473.50	475.00	476.50	478.00	479.50	481.00	482.50	484.00	485.50	487.00	488.50	490.00	491.50	493.00	494.50	496.00	497.50	499.00	500.50	502.00	503.50	505.00	506.50	508.00	509.50	511.00	512.50	514.00	515.50	517.00	518.50	520.00	521.50	523.00	524.50	526.00	527.50	529.00	530.50	532.00	533.50	535.00	536.50	538.00	539.50	541.00	542.50	544.00	545.50	547.00	548.50	550.00	551.50	553.00	554.50	556.00	557.50	559.00	560.50	562.00	563.50	565.00	566.50	568.00	569.50	571.00	572.50	574.00	575.50	577.00	578.50	580.00	581.50	583.00	584.50	586.00	587.50	589.00	590.50	592.00	593.50	595.00	596.50	598.00	599.50	601.00	602.50	604.00	605.50	607.00	608.50	610.00	611.50	613.00	614.50	616.00	617.50	619.00	620.50	622.00	623.50	625.00	626.50	628.00	629.50	631.00	632.50	634.00	635.50	637.00	638.50	640.00	641.50	643.00	644.50	646.00	647.50	649.00	650.50	652.00	653.50	655.00	656.50	658.00	659.50	661.00	662.50	664.00	665.50	667.00	668.50	670.00	671.50	673.00	674.50	676.00	677.50	679.00	680.50	682.00	683.50	685.00	686.50	688.00	689.50	691.00	692.50	694.00	695.50	697.00	698.50	700.00	701.50	703.00	704.50	706.00	707.50	709.00	710.50	712.00	713.50	715.00	716.50	718.00	719.50	721.00	722.50	724.00	725.50	727.00	728.50	730.00	731.50	733.00	734.50	736.00	737.50	739.00	740.50	742.00	743.50	745.00	746.50	748.00	749.50	751.00	752.50	754.00	755.50	757.00	758.50	760.00	761.50	763.00	764.50	766.00	767.50	769.00	770.50	772.00	773.50	775.00	776.50	778.00	779.50	781.00	782.50	784.00	785.50	787.00	788.50	790.00	791.50	793.00	794.50	796.00	797.50	799.00	800.50	802.00	803.50	805.00	806.50	808.00	809.50	811.00	812.50	814.00	815.50	817.00	818.50	820.00	821.50	823.00	824.50	826.00	827.50	829.00	830.50	832.00	833.50	835.00	836.50	838.00	839.50	841.00	842.50	844.00	845.50	847.00	848.50	850.00	851.50	853.00	854.50	856.00	857.50	859.00	860.50	862.00	863.50	865.00	866.50	868.00	869.50	871.00	872.50	874.00	875.50	877.00	878.50	880.00	881.50	883.00	884.50	886.00	887.50	889.00	890.50	892.00	893.50	895.00	896.50	898.00	899.50	901.00	902.50	904.00	905.50	907.00	908.50	910.00	911.50	913.00	914.50	916.00	917.50	919.00	920.50	922.00	923.50	925.00	926.50	928.00	929.50	931.00	932.50	934.00	935.50	937.00	938.50	940.00	941.50	943.00	944.50	946.00	947.50	949.00	950.50	952.00	953.50	955.00	956.50	958.00	959.50	961.00	962.50	964.00	965.50	967.00	968.50	970.00	971.50	973.00	974.50	976.00	977.50	979.00	980.50	982.00	983.50	985.00	986.50	988.00	989.50	991.00	992.50	994.00	995.50	997.00	998.50	1000.00

Key to Horsepower Correction Factor =1.0



The Driving Force in Power Transmission.

Horsepower Rating for 0.25 Inch Wide XL Section Belt (0.200 Inch Pitch)

RPM of FASTER Shaft	Rated Horsepower for Small Pulley (Number of Grooves and Pitch Diameter, Inches)												
	10XL 0.637	11XL 0.700	12XL 0.764	14XL 0.891	15XL 0.955	16XL 1.019	18XL 1.146	20XL 1.273	21XL 1.337	22XL 1.401	24XL 1.528	28XL 1.783	30XL 1.910
950	0.034	0.038	0.041	0.048	0.051	0.055	0.062	0.069	0.072	0.075	0.082	0.096	0.10
1160	0.042	0.046	0.050	0.059	0.063	0.067	0.075	0.084	0.088	0.092	0.10	0.12	0.13
1425	0.051	0.057	0.062	0.072	0.077	0.082	0.093	0.10	0.11	0.11	0.12	0.14	0.15
1750	0.063	0.069	0.076	0.088	0.095	0.10	0.11	0.13	0.13	0.14	0.15	0.18	0.19
2850	0.10	0.11	0.12	0.14	0.15	0.16	0.18	0.20	0.21	0.22	0.24	0.28	0.30
3450	0.12	0.14	0.15	0.17	0.19	0.20	0.22	0.25	0.26	0.27	0.29	0.34	0.36
100	0.004	0.004	0.004	0.005	0.005	0.006	0.007	0.007	0.008	0.008	0.009	0.010	0.011
200	0.007	0.008	0.009	0.010	0.011	0.012	0.013	0.014	0.015	0.016	0.017	0.020	0.022
300	0.011	0.012	0.013	0.015	0.016	0.017	0.020	0.022	0.023	0.024	0.026	0.030	0.033
400	0.014	0.016	0.017	0.020	0.022	0.023	0.026	0.029	0.030	0.032	0.035	0.040	0.043
500	0.018	0.020	0.022	0.025	0.027	0.029	0.033	0.036	0.038	0.040	0.043	0.051	0.054
600	0.022	0.024	0.026	0.030	0.033	0.035	0.039	0.043	0.046	0.048	0.052	0.061	0.065
700	0.025	0.028	0.030	0.035	0.038	0.040	0.046	0.051	0.053	0.056	0.061	0.071	0.076
800	0.029	0.032	0.035	0.040	0.043	0.046	0.052	0.058	0.061	0.064	0.069	0.081	0.087
900	0.033	0.036	0.039	0.046	0.049	0.052	0.059	0.065	0.068	0.072	0.078	0.091	0.097
1000	0.036	0.040	0.043	0.051	0.054	0.058	0.065	0.072	0.076	0.079	0.087	0.10	0.11
1100	0.040	0.044	0.048	0.056	0.060	0.064	0.072	0.079	0.083	0.087	0.095	0.11	0.12
1200	0.043	0.048	0.052	0.061	0.065	0.069	0.078	0.087	0.091	0.095	0.10	0.12	0.13
1300	0.047	0.052	0.056	0.066	0.070	0.075	0.084	0.094	0.098	0.10	0.11	0.13	0.14
1400	0.051	0.056	0.061	0.071	0.076	0.081	0.091	0.10	0.11	0.11	0.12	0.14	0.15
1500	0.054	0.060	0.065	0.076	0.081	0.087	0.097	0.11	0.11	0.12	0.13	0.15	0.16
1600	0.058	0.064	0.069	0.081	0.087	0.092	0.10	0.12	0.12	0.13	0.14	0.16	0.17
1700	0.061	0.068	0.074	0.086	0.092	0.098	0.11	0.12	0.13	0.13	0.15	0.17	0.18
1800	0.065	0.071	0.078	0.091	0.097	0.10	0.12	0.13	0.14	0.14	0.16	0.18	0.19
2000	0.072	0.079	0.087	0.10	0.11	0.12	0.13	0.14	0.15	0.16	0.17	0.20	0.21
2200	0.079	0.087	0.095	0.11	0.12	0.13	0.14	0.16	0.17	0.17	0.19	0.22	0.24
2400	0.087	0.095	0.10	0.12	0.13	0.14	0.16	0.17	0.18	0.19	0.21	0.24	0.26
2600	0.094	0.10	0.11	0.13	0.14	0.15	0.17	0.19	0.20	0.20	0.22	0.26	0.28
2800	0.10	0.11	0.12	0.14	0.15	0.16	0.18	0.20	0.21	0.22	0.24	0.28	0.30
3000	0.11	0.12	0.13	0.15	0.16	0.17	0.19	0.21	0.22	0.24	0.26	0.30	0.32
3200	0.12	0.13	0.14	0.16	0.17	0.18	0.21	0.23	0.24	0.25	0.27	0.32	0.34
3400	0.12	0.13	0.15	0.17	0.18	0.19	0.22	0.24	0.25	0.27	0.29	0.33	0.36
3600	0.13	0.14	0.16	0.18	0.19	0.21	0.23	0.26	0.27	0.28	0.31	0.35	0.38
3800	0.14	0.15	0.16	0.19	0.20	0.22	0.24	0.27	0.28	0.30	0.32	0.37	0.40
4000	0.14	0.16	0.17	0.20	0.21	0.23	0.26	0.28	0.30	0.31	0.34	0.39	0.41
4200	0.15	0.17	0.18	0.21	0.22	0.24	0.27	0.30	0.31	0.33	0.35	0.41	0.43
4400	0.16	0.17	0.19	0.22	0.24	0.25	0.28	0.31	0.33	0.34	0.37	0.42	0.45
4600	0.17	0.18	0.20	0.23	0.25	0.26	0.29	0.32	0.34	0.35	0.38	0.44	0.47
4800	0.17	0.19	0.21	0.24	0.26	0.27	0.31	0.34	0.35	0.37	0.40	0.46	0.49
5000	0.18	0.20	0.21	0.25	0.27	0.28	0.32	0.35	0.37	0.38	0.41	0.48	0.50
5500					0.29	0.31	0.35	0.38	0.40	0.42	0.45	0.52	0.55
6000					0.32	0.34	0.38	0.41	0.43	0.45	0.49	0.55	0.58
6500					0.34	0.36	0.40	0.45	0.46	0.48	0.52	0.59	0.62
7000					0.37	0.39	0.43	0.48	0.50	0.52	0.55	0.62	0.65
7500					0.39	0.41	0.46	0.50	0.53	0.55	0.58	0.65	0.68
8000							0.49	0.53	0.55	0.57	0.61	0.68	0.71
8500							0.51	0.56	0.58	0.60	0.64	0.71	0.73
9000							0.54	0.58	0.61	0.63	0.67	0.73	0.75
9500							0.56	0.61	0.63	0.65	0.69	0.75	0.77
10000							0.58	0.63	0.65	0.68	0.71	0.76	0.78

Use this sprocket and rpm only if required to obtain speed ratio or to meet diameter limitations. See Engineering Section II-5, Sprocket Diameter—Speed, on page 138.



Horsepower Rating for 0.375 Inch Wide XL Section Belt (0.200 Inch Pitch)

RPM of Faster Shaft	Rated Horsepower for Small Pulley (Number of Grooves and Pitch Diameter, Inches)												
	10XL 0.637	11XL 0.700	12XL 0.764	14XL 0.891	15XL 0.955	16XL 1.019	18XL 1.146	20XL 1.273	21XL 1.337	22XL 1.401	24XL 1.528	28XL 1.783	30XL 1.910
950	0.055	0.061	0.066	0.077	0.083	0.089	0.100	0.11	0.12	0.12	0.13	0.15	0.17
1160	0.068	0.074	0.081	0.095	0.10	0.11	0.12	0.14	0.14	0.15	0.16	0.19	0.20
1425	0.083	0.091	0.100	0.12	0.12	0.13	0.15	0.17	0.17	0.18	0.20	0.23	0.25
1750	0.10	0.11	0.12	0.14	0.15	0.16	0.18	0.20	0.21	0.22	0.24	0.28	0.30
2850	0.17	0.18	0.20	0.23	0.25	0.26	0.30	0.33	0.35	0.36	0.39	0.46	0.49
3450	0.20	0.22	0.24	0.28	0.30	0.32	0.36	0.40	0.42	0.43	0.47	0.55	0.58
100	0.006	0.006	0.007	0.008	0.009	0.009	0.010	0.012	0.012	0.013	0.014	0.016	0.017
200	0.012	0.013	0.014	0.016	0.017	0.019	0.021	0.023	0.024	0.026	0.028	0.033	0.035
300	0.017	0.019	0.021	0.024	0.026	0.028	0.031	0.035	0.037	0.038	0.042	0.049	0.052
400	0.023	0.026	0.028	0.033	0.035	0.037	0.042	0.047	0.049	0.051	0.056	0.065	0.070
500	0.029	0.032	0.035	0.041	0.044	0.047	0.052	0.058	0.061	0.064	0.070	0.082	0.087
600	0.035	0.038	0.042	0.049	0.052	0.056	0.063	0.070	0.073	0.077	0.084	0.098	0.10
700	0.041	0.045	0.049	0.057	0.061	0.065	0.073	0.082	0.086	0.090	0.098	0.11	0.12
800	0.047	0.051	0.056	0.065	0.070	0.075	0.084	0.093	0.098	0.10	0.11	0.13	0.14
900	0.052	0.058	0.063	0.073	0.079	0.084	0.094	0.10	0.11	0.12	0.13	0.15	0.16
1000	0.058	0.064	0.070	0.082	0.087	0.093	0.10	0.12	0.12	0.13	0.14	0.16	0.17
1100	0.064	0.070	0.077	0.090	0.096	0.10	0.12	0.13	0.13	0.14	0.15	0.18	0.19
1200	0.070	0.077	0.084	0.098	0.10	0.11	0.13	0.14	0.15	0.15	0.17	0.20	0.21
1300	0.076	0.083	0.091	0.11	0.11	0.12	0.14	0.15	0.16	0.17	0.18	0.21	0.23
1400	0.082	0.090	0.098	0.11	0.12	0.13	0.15	0.16	0.17	0.18	0.20	0.23	0.24
1500	0.087	0.096	0.10	0.12	0.13	0.14	0.16	0.17	0.18	0.19	0.21	0.24	0.26
1600	0.093	0.10	0.11	0.13	0.14	0.15	0.17	0.19	0.20	0.20	0.22	0.26	0.28
1700	0.099	0.11	0.12	0.14	0.15	0.16	0.18	0.20	0.21	0.22	0.24	0.28	0.30
1800	0.10	0.12	0.13	0.15	0.16	0.17	0.19	0.21	0.22	0.23	0.25	0.29	0.31
2000	0.12	0.13	0.14	0.16	0.17	0.19	0.21	0.23	0.24	0.26	0.28	0.32	0.35
2200	0.13	0.14	0.15	0.18	0.19	0.20	0.23	0.25	0.27	0.28	0.31	0.36	0.38
2400	0.14	0.15	0.17	0.20	0.21	0.22	0.25	0.28	0.29	0.31	0.33	0.39	0.41
2600	0.15	0.17	0.18	0.21	0.23	0.24	0.27	0.30	0.32	0.33	0.36	0.42	0.45
2800	0.16	0.18	0.20	0.23	0.24	0.26	0.29	0.32	0.34	0.36	0.39	0.45	0.48
3000	0.17	0.19	0.21	0.24	0.26	0.28	0.31	0.35	0.36	0.38	0.41	0.48	0.51
3200	0.19	0.20	0.22	0.26	0.28	0.30	0.33	0.37	0.39	0.40	0.44	0.51	0.54
3400	0.20	0.22	0.24	0.28	0.30	0.31	0.35	0.39	0.41	0.43	0.47	0.54	0.58
3600	0.21	0.23	0.25	0.29	0.31	0.33	0.37	0.41	0.43	0.45	0.49	0.57	0.61
3800	0.22	0.24	0.26	0.31	0.33	0.35	0.39	0.44	0.46	0.48	0.52	0.60	0.64
4000	0.23	0.25	0.28	0.32	0.35	0.37	0.41	0.46	0.48	0.50	0.54	0.63	0.67
4200	0.24	0.27	0.29	0.34	0.36	0.39	0.43	0.48	0.50	0.52	0.57	0.66	0.70
4400	0.26	0.28	0.31	0.35	0.38	0.40	0.45	0.50	0.52	0.55	0.59	0.68	0.73
4600	0.27	0.29	0.32	0.37	0.40	0.42	0.47	0.52	0.55	0.57	0.62	0.71	0.76
4800	0.28	0.31	0.33	0.39	0.41	0.44	0.49	0.54	0.57	0.59	0.64	0.74	0.79
5000	0.29	0.32	0.35	0.40	0.43	0.46	0.51	0.56	0.59	0.62	0.67	0.77	0.81
5500					0.47	0.50	0.56	0.62	0.65	0.67	0.73	0.83	0.88
6000					0.51	0.54	0.61	0.67	0.70	0.73	0.79	0.89	0.94
6500					0.55	0.59	0.65	0.72	0.75	0.78	0.84	0.95	1.00
7000					0.59	0.63	0.70	0.77	0.80	0.83	0.89	1.01	1.06
7500					0.63	0.67	0.74	0.81	0.85	0.88	0.94	1.06	1.10
8000							0.79	0.86	0.89	0.93	0.99	1.10	1.15
8500							0.83	0.90	0.94	0.97	1.03	1.14	1.18
9000							0.87	0.94	0.98	1.01	1.08	1.18	1.22
9500							0.91	0.98	1.02	1.05	1.11	1.21	1.24
10000							0.94	1.02	1.06	1.09	1.15	1.23	1.26

Use this sprocket and rpm only if required to obtain speed ratio or to meet diameter limitations. See Engineering Section II-5, Sprocket Diameter—Speed, on page 138.

Horsepower Rating for 0.50 Inch Wide L Section Belt (0.375 Inch Pitch)

RPM of Faster Shaft	Rated Horsepower for Small Pulley (Number of Grooves and Pitch Diameter, Inches)																	
	10L 1.194	12L 1.432	14L 1.671	16L 1.910	18L 2.149	19L 2.268	20L 2.387	21L 2.507	22L 2.626	24L 2.865	26L 3.104	28L 3.342	30L 3.581	32L 3.820	36L 4.297	40L 4.775	44L 5.252	48L 5.730
725	0.17	0.20	0.24	0.27	0.31	0.32	0.34	0.36	0.37	0.41	0.44	0.47	0.51	0.54	0.61	0.67	0.74	0.81
870	0.20	0.24	0.28	0.33	0.37	0.39	0.41	0.43	0.45	0.49	0.53	0.57	0.61	0.65	0.73	0.81	0.88	0.96
950	0.22	0.27	0.31	0.36	0.40	0.42	0.44	0.47	0.49	0.53	0.57	0.62	0.66	0.71	0.79	0.88	0.96	1.05
1160	0.27	0.33	0.38	0.43	0.49	0.51	0.54	0.57	0.59	0.65	0.70	0.75	0.81	0.86	0.96	1.06	1.16	1.26
1425	0.33	0.40	0.47	0.53	0.60	0.63	0.66	0.69	0.73	0.79	0.86	0.92	0.98	1.05	1.17	1.29	1.41	1.53
1750	0.41	0.49	0.57	0.65	0.73	0.77	0.81	0.85	0.89	0.97	1.04	1.12	1.20	1.27	1.42	1.56	1.70	1.83
2850		0.79	0.92	1.05	1.17	1.23	1.29	1.35	1.41	1.53	1.64	1.75	1.86	1.96	2.15	2.33	2.48	2.61
3450			1.11	1.25	1.40	1.47	1.54	1.61	1.68	1.81	1.93	2.05	2.17	2.28	2.47	2.63	2.75	2.83
100	0.023	0.028	0.033	0.037	0.042	0.044	0.047	0.049	0.052	0.056	0.061	0.066	0.070	0.075	0.084	0.094	0.10	0.11
200	0.047	0.056	0.066	0.075	0.084	0.089	0.094	0.098	0.10	0.11	0.12	0.13	0.14	0.15	0.17	0.19	0.21	0.22
300	0.070	0.084	0.098	0.11	0.13	0.13	0.14	0.15	0.15	0.17	0.18	0.20	0.21	0.22	0.25	0.28	0.31	0.34
400	0.094	0.11	0.13	0.15	0.17	0.18	0.19	0.20	0.21	0.22	0.24	0.26	0.28	0.30	0.34	0.37	0.41	0.45
500	0.12	0.14	0.16	0.19	0.21	0.22	0.23	0.25	0.26	0.28	0.30	0.33	0.35	0.37	0.42	0.47	0.51	0.56
600	0.14	0.17	0.20	0.22	0.25	0.27	0.28	0.29	0.31	0.34	0.36	0.39	0.42	0.45	0.50	0.56	0.61	0.67
700	0.16	0.20	0.23	0.26	0.29	0.31	0.33	0.34	0.36	0.39	0.42	0.46	0.49	0.52	0.59	0.65	0.71	0.78
800	0.19	0.22	0.26	0.30	0.34	0.36	0.37	0.39	0.41	0.45	0.49	0.52	0.56	0.60	0.67	0.74	0.81	0.89
900	0.21	0.25	0.29	0.34	0.38	0.40	0.42	0.44	0.46	0.50	0.55	0.59	0.63	0.67	0.75	0.83	0.91	0.99
1000	0.23	0.28	0.33	0.37	0.42	0.44	0.47	0.49	0.51	0.56	0.60	0.65	0.70	0.74	0.83	0.92	1.01	1.10
1100	0.26	0.31	0.36	0.41	0.46	0.49	0.51	0.54	0.56	0.61	0.66	0.71	0.76	0.81	0.91	1.01	1.11	1.20
1200	0.28	0.34	0.39	0.45	0.50	0.53	0.56	0.59	0.61	0.67	0.72	0.78	0.83	0.89	0.99	1.10	1.20	1.30
1300	0.30	0.36	0.42	0.49	0.55	0.57	0.60	0.63	0.66	0.72	0.78	0.84	0.90	0.96	1.07	1.19	1.30	1.41
1400	0.33	0.39	0.46	0.52	0.59	0.62	0.65	0.68	0.71	0.78	0.84	0.90	0.97	1.03	1.15	1.27	1.39	1.50
1500	0.35	0.42	0.49	0.56	0.63	0.66	0.70	0.73	0.76	0.83	0.90	0.97	1.03	1.10	1.23	1.36	1.48	1.60
1600	0.37	0.45	0.52	0.60	0.67	0.71	0.74	0.78	0.81	0.89	0.96	1.03	1.10	1.17	1.30	1.44	1.57	1.69
1700	0.40	0.48	0.55	0.63	0.71	0.75	0.79	0.83	0.86	0.94	1.02	1.09	1.16	1.24	1.38	1.52	1.66	1.79
1800		0.50	0.59	0.67	0.75	0.79	0.83	0.87	0.91	0.99	1.07	1.15	1.23	1.30	1.45	1.60	1.74	1.87
1900		0.53	0.62	0.71	0.79	0.83	0.88	0.92	0.96	1.05	1.13	1.21	1.29	1.37	1.53	1.68	1.82	1.96
2000		0.56	0.65	0.74	0.83	0.88	0.92	0.97	1.01	1.10	1.19	1.27	1.36	1.44	1.60	1.76	1.90	2.04
2200		0.61	0.71	0.81	0.91	0.96	1.01	1.06	1.11	1.20	1.30	1.39	1.48	1.57	1.74	1.90	2.06	2.20
2400		0.67	0.78	0.89	0.99	1.05	1.10	1.15	1.20	1.30	1.41	1.50	1.60	1.69	1.87	2.04	2.20	2.35
2600		0.72	0.84	0.96	1.07	1.13	1.19	1.24	1.30	1.41	1.51	1.62	1.72	1.82	2.00	2.18	2.33	2.47
2800		0.78	0.90	1.03	1.15	1.21	1.27	1.33	1.39	1.50	1.62	1.73	1.83	1.93	2.12	2.30	2.45	2.59
3000		0.83	0.97	1.10	1.23	1.29	1.36	1.42	1.48	1.60	1.72	1.83	1.94	2.04	2.24	2.41	2.56	2.68
3200			1.03	1.17	1.30	1.37	1.44	1.50	1.57	1.69	1.82	1.93	2.04	2.15	2.35	2.51	2.65	2.76
3400			1.09	1.24	1.38	1.45	1.52	1.59	1.66	1.79	1.91	2.03	2.14	2.25	2.44	2.61	2.73	2.82
3600			1.15	1.30	1.45	1.53	1.60	1.67	1.74	1.87	2.00	2.12	2.24	2.35	2.53	2.68	2.79	2.86
3800			1.21	1.37	1.53	1.60	1.68	1.75	1.82	1.96	2.09	2.21	2.33	2.43	2.61	2.75	2.84	2.87
4000			1.27	1.44	1.60	1.68	1.76	1.83	1.90	2.04	2.18	2.30	2.41	2.51	2.68	2.80	2.87	2.87
4200				1.50	1.67	1.75	1.83	1.91	1.98	2.12	2.26	2.38	2.49	2.59	2.74	2.84	2.87	2.83
4400				1.57	1.74	1.82	1.90	1.98	2.06	2.20	2.33	2.45	2.56	2.65	2.79	2.87	2.86	2.78
4600				1.63	1.81	1.89	1.98	2.05	2.13	2.28	2.41	2.52	2.63	2.71	2.83	2.87	2.83	2.69
4800				1.69	1.87	1.96	2.04	2.12	2.20	2.35	2.47	2.59	2.68	2.76	2.86	2.87	2.78	2.58
5000				1.76	1.94	2.03	2.11	2.19	2.27	2.41	2.54	2.65	2.74	2.80	2.87	2.84	2.70	2.44
5200				1.82	2.00	2.09	2.18	2.26	2.33	2.47	2.60	2.70	2.78	2.84	2.87	2.80	2.60	2.26
5400				1.87	2.06	2.15	2.24	2.32	2.40	2.53	2.65	2.74	2.81	2.86	2.86	2.74	2.47	2.06
5600				1.93	2.12	2.21	2.30	2.38	2.45	2.59	2.70	2.78	2.84	2.87	2.83	2.66	2.32	1.82
5800				1.99	2.18	2.27	2.36	2.44	2.51	2.64	2.74	2.82	2.86	2.87	2.79	2.56	2.15	1.55
6000				2.04	2.24	2.33	2.41	2.49	2.56	2.68	2.78	2.84	2.87	2.87	2.74	2.44	1.94	1.24

Use this sprocket and rpm only if required to obtain speed ratio or to meet diameter limitations. See Engineering Section II-5, Sprocket Diameter—Speed, on page 138.

Sprocket surface speeds over 6,500 fpm; special pulleys are required. See Engineering Section II-5, Sprocket Diameter—Speed, on page 138.



Horsepower Rating for 0.75 Inch Wide L Section Belt (0.375 Inch Pitch)

RPM of Faster Shaft	Rated Horsepower for Small Pulley (Number of Grooves and Pitch Diameter, Inches)																	
	10L 1.194	12L 1.432	14L 1.671	16L 1.910	18L 2.149	19L 2.268	20L 2.387	21L 2.507	22L 2.626	24L 2.865	26L 3.104	28L 3.342	30L 3.581	32L 3.820	36L 4.297	40L 4.775	44L 5.252	48L 5.730
725	0.27	0.33	0.38	0.43	0.49	0.52	0.54	0.57	0.60	0.65	0.70	0.76	0.81	0.86	0.97	1.08	1.18	1.29
870	0.33	0.39	0.46	0.52	0.59	0.62	0.65	0.68	0.71	0.78	0.84	0.91	0.97	1.04	1.16	1.29	1.41	1.54
950	0.36	0.43	0.50	0.57	0.64	0.67	0.71	0.74	0.78	0.85	0.92	0.99	1.06	1.13	1.27	1.40	1.54	1.67
1160	0.43	0.52	0.61	0.69	0.78	0.82	0.86	0.91	0.95	1.04	1.12	1.20	1.29	1.37	1.54	1.70	1.86	2.02
1425	0.53	0.64	0.74	0.85	0.95	1.01	1.06	1.11	1.16	1.27	1.37	1.47	1.57	1.67	1.87	2.07	2.26	2.45
1750	0.65	0.78	0.91	1.04	1.17	1.23	1.30	1.36	1.42	1.55	1.67	1.79	1.91	2.03	2.27	2.50	2.72	2.93
2850		1.27	1.47	1.67	1.87	1.97	2.07	2.16	2.26	2.45	2.63	2.80	2.97	3.14	3.45	3.73	3.97	4.18
3450			1.77	2.01	2.24	2.35	2.46	2.57	2.68	2.89	3.10	3.29	3.47	3.64	3.95	4.20	4.40	4.53
100	0.037	0.045	0.052	0.060	0.067	0.071	0.075	0.079	0.082	0.090	0.097	0.10	0.11	0.12	0.13	0.15	0.16	0.18
200	0.075	0.090	0.10	0.12	0.13	0.14	0.15	0.16	0.16	0.18	0.19	0.21	0.22	0.24	0.27	0.30	0.33	0.36
300	0.11	0.13	0.16	0.18	0.20	0.21	0.22	0.24	0.25	0.27	0.29	0.31	0.34	0.36	0.40	0.45	0.49	0.54
400	0.15	0.18	0.21	0.24	0.27	0.28	0.30	0.31	0.33	0.36	0.39	0.42	0.45	0.48	0.54	0.60	0.66	0.72
500	0.19	0.22	0.26	0.30	0.34	0.36	0.37	0.39	0.41	0.45	0.49	0.52	0.56	0.60	0.67	0.75	0.82	0.89
600	0.22	0.27	0.31	0.36	0.40	0.43	0.45	0.47	0.49	0.54	0.58	0.63	0.67	0.72	0.81	0.89	0.98	1.07
700	0.26	0.31	0.37	0.42	0.47	0.50	0.52	0.55	0.58	0.63	0.68	0.73	0.78	0.84	0.94	1.04	1.14	1.25
800	0.30	0.36	0.42	0.48	0.54	0.57	0.60	0.63	0.66	0.72	0.78	0.84	0.89	0.95	1.07	1.19	1.30	1.42
900	0.34	0.40	0.47	0.54	0.61	0.64	0.67	0.71	0.74	0.81	0.87	0.94	1.00	1.07	1.20	1.33	1.46	1.59
1000	0.37	0.45	0.52	0.60	0.67	0.71	0.75	0.78	0.82	0.89	0.97	1.04	1.11	1.19	1.33	1.48	1.62	1.76
1100	0.41	0.49	0.58	0.66	0.74	0.78	0.82	0.86	0.90	0.98	1.06	1.14	1.22	1.30	1.46	1.62	1.77	1.92
1200	0.45	0.54	0.63	0.72	0.81	0.85	0.89	0.94	0.98	1.07	1.16	1.25	1.33	1.42	1.59	1.76	1.92	2.09
1300	0.49	0.58	0.68	0.78	0.87	0.92	0.97	1.02	1.06	1.16	1.25	1.35	1.44	1.53	1.72	1.90	2.07	2.25
1400	0.52	0.63	0.73	0.84	0.94	0.99	1.04	1.09	1.14	1.25	1.35	1.45	1.55	1.65	1.84	2.03	2.22	2.41
1500	0.56	0.67	0.78	0.89	1.00	1.06	1.11	1.17	1.22	1.33	1.44	1.55	1.65	1.76	1.97	2.17	2.37	2.56
1600	0.60	0.72	0.84	0.95	1.07	1.13	1.19	1.25	1.30	1.42	1.53	1.65	1.76	1.87	2.09	2.30	2.51	2.71
1700	0.64	0.76	0.89	1.01	1.14	1.20	1.26	1.32	1.38	1.50	1.62	1.74	1.86	1.98	2.21	2.43	2.65	2.86
1800		0.81	0.94	1.07	1.20	1.27	1.33	1.40	1.46	1.59	1.72	1.84	1.97	2.09	2.33	2.56	2.78	3.00
1900		0.85	0.99	1.13	1.27	1.34	1.40	1.47	1.54	1.67	1.81	1.94	2.07	2.20	2.45	2.69	2.92	3.14
2000		0.89	1.04	1.19	1.33	1.40	1.48	1.55	1.62	1.76	1.90	2.03	2.17	2.30	2.56	2.81	3.05	3.27
2200		0.98	1.14	1.30	1.46	1.54	1.62	1.69	1.77	1.92	2.07	2.22	2.37	2.51	2.78	3.05	3.29	3.52
2400		1.07	1.25	1.42	1.59	1.67	1.76	1.84	1.92	2.09	2.25	2.41	2.56	2.71	3.00	3.27	3.52	3.75
2600		1.16	1.35	1.53	1.72	1.81	1.90	1.99	2.07	2.25	2.42	2.59	2.75	2.91	3.21	3.48	3.73	3.96
2800		1.25	1.45	1.65	1.84	1.94	2.03	2.13	2.22	2.41	2.59	2.76	2.93	3.09	3.40	3.68	3.93	4.14
3000		1.33	1.55	1.76	1.97	2.07	2.17	2.27	2.37	2.56	2.75	2.93	3.10	3.27	3.58	3.86	4.10	4.30
3200			1.65	1.87	2.09	2.20	2.30	2.41	2.51	2.71	2.91	3.09	3.27	3.44	3.75	4.02	4.25	4.42
3400			1.74	1.98	2.21	2.32	2.43	2.54	2.65	2.86	3.06	3.25	3.43	3.60	3.91	4.17	4.37	4.51
3600			1.84	2.09	2.33	2.45	2.56	2.67	2.78	3.00	3.21	3.40	3.58	3.75	4.05	4.30	4.47	4.57
3800			1.94	2.20	2.45	2.57	2.69	2.80	2.92	3.14	3.35	3.54	3.73	3.89	4.18	4.40	4.54	4.60
4000			2.03	2.30	2.56	2.69	2.81	2.93	3.05	3.27	3.48	3.68	3.86	4.02	4.30	4.49	4.59	4.59
4200				2.41	2.67	2.80	2.93	3.05	3.17	3.40	3.61	3.81	3.98	4.14	4.39	4.55	4.60	4.53
4400				2.51	2.78	2.92	3.05	3.17	3.29	3.52	3.73	3.93	4.10	4.25	4.47	4.59	4.58	4.44
4600				2.61	2.89	3.03	3.16	3.29	3.41	3.64	3.85	4.04	4.20	4.34	4.53	4.60	4.53	4.31
4800				2.71	3.00	3.14	3.27	3.40	3.52	3.75	3.96	4.14	4.30	4.42	4.57	4.59	4.44	4.13
5000				2.81	3.10	3.24	3.38	3.51	3.63	3.86	4.06	4.23	4.38	4.49	4.60	4.55	4.32	3.90
5200				2.91	3.21	3.35	3.48	3.61	3.73	3.96	4.16	4.32	4.45	4.54	4.60	4.48	4.16	3.62
5400				3.00	3.30	3.45	3.58	3.71	3.83	4.05	4.24	4.39	4.50	4.57	4.58	4.38	3.96	3.29
5600				3.09	3.40	3.54	3.68	3.81	3.93	4.14	4.32	4.45	4.55	4.59	4.53	4.25	3.72	2.91
5800				3.18	3.49	3.64	3.77	3.90	4.02	4.22	4.39	4.51	4.58	4.60	4.47	4.09	3.44	2.48
6000				3.27	3.58	3.73	3.86	3.98	4.10	4.30	4.45	4.55	4.60	4.59	4.38	3.90	3.11	1.99

Use this sprocket and rpm only if required to obtain speed ratio or to meet diameter limitations. See Engineering Section II-5, Sprocket Diameter—Speed, on page 138.

Sprocket surface speeds over 6,500 fpm; special pulleys are required. See Engineering Section II-5, Sprocket Diameter—Speed, on page 138.

Horsepower Rating for 1.00 Inch Wide L Section Belt (0.375 Inch Pitch)

RPM of Faster Shaft	Rated Horsepower for Small Pulley (Number of Grooves and Pitch Diameter, Inches)																	
	10L 1.194	12L 1.432	14L 1.671	16L 1.910	18L 2.149	19L 2.268	20L 2.387	21L 2.507	22L 2.626	24L 2.865	26L 3.104	28L 3.342	30L 3.581	32L 3.820	36L 4.297	40L 4.775	44L 5.252	48L 5.730
725	0.38	0.45	0.53	0.60	0.68	0.72	0.75	0.79	0.83	0.90	0.98	1.05	1.13	1.20	1.35	1.50	1.64	1.79
870	0.45	0.54	0.63	0.72	0.81	0.86	0.90	0.95	0.99	1.08	1.17	1.26	1.35	1.44	1.61	1.79	1.96	2.14
950	0.49	0.59	0.69	0.79	0.89	0.94	0.99	1.03	1.08	1.18	1.28	1.37	1.47	1.57	1.76	1.95	2.14	2.32
1160	0.60	0.72	0.84	0.96	1.08	1.14	1.20	1.26	1.32	1.44	1.56	1.67	1.79	1.91	2.14	2.36	2.59	2.81
1425	0.74	0.89	1.03	1.18	1.33	1.40	1.47	1.54	1.62	1.76	1.90	2.04	2.18	2.32	2.60	2.87	3.14	3.40
1750	0.91	1.09	1.27	1.45	1.62	1.71	1.80	1.89	1.97	2.15	2.32	2.49	2.66	2.82	3.15	3.47	3.77	4.07
2850		1.76	2.04	2.32	2.60	2.74	2.87	3.01	3.14	3.40	3.65	3.89	4.13	4.36	4.79	5.17	5.52	5.81
3450			2.46	2.79	3.11	3.27	3.42	3.58	3.73	4.02	4.30	4.57	4.82	5.06	5.48	5.84	6.11	6.29
100	0.052	0.062	0.073	0.083	0.094	0.099	0.10	0.11	0.11	0.12	0.14	0.15	0.16	0.17	0.19	0.21	0.23	0.25
200	0.10	0.12	0.15	0.17	0.19	0.20	0.21	0.22	0.23	0.25	0.27	0.29	0.31	0.33	0.37	0.42	0.46	0.50
300	0.16	0.19	0.22	0.25	0.28	0.30	0.31	0.33	0.34	0.37	0.41	0.44	0.47	0.50	0.56	0.62	0.69	0.75
400	0.21	0.25	0.29	0.33	0.37	0.40	0.42	0.44	0.46	0.50	0.54	0.58	0.62	0.67	0.75	0.83	0.91	1.00
500	0.26	0.31	0.36	0.42	0.47	0.49	0.52	0.55	0.57	0.62	0.68	0.73	0.78	0.83	0.93	1.04	1.14	1.24
600	0.31	0.37	0.44	0.50	0.56	0.59	0.62	0.65	0.69	0.75	0.81	0.87	0.93	1.00	1.12	1.24	1.36	1.49
700	0.36	0.44	0.51	0.58	0.65	0.69	0.73	0.76	0.80	0.87	0.94	1.02	1.09	1.16	1.30	1.45	1.59	1.73
800	0.42	0.50	0.58	0.67	0.75	0.79	0.83	0.87	0.91	1.00	1.08	1.16	1.24	1.32	1.49	1.65	1.81	1.97
900	0.47	0.56	0.65	0.75	0.84	0.89	0.93	0.98	1.03	1.12	1.21	1.30	1.40	1.49	1.67	1.85	2.03	2.21
1000	0.52	0.62	0.73	0.83	0.93	0.99	1.04	1.09	1.14	1.24	1.34	1.45	1.55	1.65	1.85	2.05	2.25	2.44
1100	0.57	0.69	0.80	0.91	1.03	1.08	1.14	1.20	1.25	1.36	1.48	1.59	1.70	1.81	2.03	2.25	2.46	2.67
1200	0.62	0.75	0.87	1.00	1.12	1.18	1.24	1.30	1.36	1.49	1.61	1.73	1.85	1.97	2.21	2.44	2.67	2.90
1300	0.68	0.81	0.94	1.08	1.21	1.28	1.34	1.41	1.48	1.61	1.74	1.87	2.00	2.13	2.38	2.63	2.88	3.12
1400	0.73	0.87	1.02	1.16	1.30	1.37	1.45	1.52	1.59	1.73	1.87	2.01	2.15	2.29	2.56	2.82	3.09	3.34
1500	0.78	0.93	1.09	1.24	1.40	1.47	1.55	1.62	1.70	1.85	2.00	2.15	2.30	2.44	2.73	3.01	3.29	3.56
1600	0.83	1.00	1.16	1.32	1.49	1.57	1.65	1.73	1.81	1.97	2.13	2.29	2.44	2.60	2.90	3.20	3.49	3.77
1700	0.88	1.06	1.23	1.41	1.58	1.66	1.75	1.83	1.92	2.09	2.26	2.42	2.59	2.75	3.07	3.38	3.68	3.97
1800		1.12	1.30	1.49	1.67	1.76	1.85	1.94	2.03	2.21	2.38	2.56	2.73	2.90	3.23	3.56	3.87	4.17
1900		1.18	1.37	1.57	1.76	1.85	1.95	2.04	2.14	2.32	2.51	2.69	2.87	3.05	3.40	3.73	4.05	4.36
2000		1.24	1.45	1.65	1.85	1.95	2.05	2.15	2.25	2.44	2.63	2.82	3.01	3.20	3.56	3.90	4.23	4.54
2200		1.36	1.59	1.81	2.03	2.14	2.25	2.35	2.46	2.67	2.88	3.09	3.29	3.49	3.87	4.23	4.57	4.89
2400		1.49	1.73	1.97	2.21	2.32	2.44	2.56	2.67	2.90	3.12	3.34	3.56	3.77	4.17	4.54	4.89	5.21
2600		1.61	1.87	2.13	2.38	2.51	2.63	2.76	2.88	3.12	3.36	3.59	3.82	4.04	4.45	4.84	5.19	5.50
2800		1.73	2.01	2.29	2.56	2.69	2.82	2.96	3.09	3.34	3.59	3.83	4.07	4.29	4.72	5.11	5.45	5.75
3000		1.85	2.15	2.44	2.73	2.87	3.01	3.15	3.29	3.56	3.82	4.07	4.31	4.54	4.98	5.36	5.69	5.97
3200			2.29	2.60	2.90	3.05	3.20	3.34	3.49	3.77	4.04	4.29	4.54	4.78	5.21	5.59	5.90	6.14
3400			2.42	2.75	3.07	3.22	3.38	3.53	3.68	3.97	4.25	4.51	4.77	5.00	5.43	5.79	6.07	6.27
3600			2.56	2.90	3.23	3.40	3.56	3.71	3.87	4.17	4.45	4.72	4.98	5.21	5.63	5.97	6.21	6.35
3800			2.69	3.05	3.40	3.56	3.73	3.89	4.05	4.36	4.65	4.92	5.17	5.41	5.81	6.11	6.31	6.39
4000			2.82	3.20	3.56	3.73	3.90	4.07	4.23	4.54	4.84	5.11	5.36	5.59	5.97	6.23	6.37	6.37
4200			3.34	3.71	3.89	4.07	4.24	4.40	4.40	4.72	5.02	5.29	5.53	5.75	6.10	6.32	6.39	6.30
4400			3.49	3.87	4.05	4.23	4.40	4.57	4.57	4.89	5.19	5.45	5.69	5.90	6.21	6.37	6.36	6.17
4600				3.63	4.02	4.21	4.39	4.57	4.74	5.06	5.35	5.61	5.84	6.03	6.29	6.39	6.29	5.98
4800				3.77	4.17	4.36	4.54	4.72	4.89	5.21	5.50	5.75	5.97	6.14	6.35	6.37	6.17	5.73
5000				3.90	4.31	4.51	4.69	4.87	5.04	5.36	5.64	5.88	6.08	6.23	6.38	6.31	6.00	5.41
5200				4.04	4.45	4.65	4.84	5.02	5.19	5.50	5.77	6.00	6.18	6.30	6.38	6.22	5.78	5.03
5400				4.17	4.59	4.79	4.98	5.16	5.32	5.63	5.89	6.10	6.25	6.35	6.36	6.08	5.50	4.57
5600				4.29	4.72	4.92	5.11	5.29	5.45	5.75	6.00	6.19	6.32	6.38	6.30	5.90	5.17	4.05
5800				4.42	4.85	5.05	5.24	5.41	5.58	5.86	6.09	6.26	6.36	6.39	6.21	5.68	4.77	3.44
6000				4.54	4.98	5.17	5.36	5.53	5.69	5.97	6.18	6.32	6.38	6.37	6.08	5.41	4.32	2.76

 Use this sprocket and rpm only if required to obtain speed ratio or to meet diameter limitations. See Engineering Section II-5, Sprocket Diameter—Speed, on page 138.

 Sprocket surface speeds over 6,500 fpm; special pulleys are required. See Engineering Section II-5, Sprocket Diameter—Speed, on page 138.



Horsepower Rating for 0.75 Inch Wide H Section Belt (0.500 Inch Pitch)

RPM of Faster Shaft	Rated Horsepower for Small Pulley (Number of Grooves and Pitch Diameter, Inches)															
	14L 2.228	16L 2.546	18L 2.865	19L 3.024	20L 3.183	21L 3.342	22L 3.501	24L 3.820	26L 4.138	28L 4.456	30L 4.775	32L 5.093	36L 5.730	40L 6.366	44L 7.003	48L 7.639
725	1.26	1.44	1.62	1.71	1.80	1.89	1.98	2.16	2.34	2.52	2.70	2.88	3.23	3.59	3.94	4.29
870	1.52	1.73	1.95	2.06	2.16	2.27	2.38	2.59	2.81	3.02	3.23	3.44	3.87	4.29	4.71	5.12
950	1.66	1.89	2.13	2.24	2.36	2.48	2.59	2.83	3.06	3.29	3.53	3.76	4.22	4.67	5.12	5.57
1160	2.02	2.31	2.59	2.73	2.88	3.02	3.16	3.44	3.73	4.01	4.29	4.57	5.12	5.67	6.20	6.74
1425		2.83	3.18	3.35	3.53	3.70	3.87	4.22	4.56	4.90	5.24	5.57	6.23	6.88	7.52	8.15
1750		3.46	3.89	4.10	4.31	4.52	4.73	5.15	5.56	5.97	6.37	6.77	7.56	8.32	9.05	9.76
2850			6.23	6.56	6.88	7.21	7.52	8.15	8.75	9.34	9.91	10.5	11.5	12.4	13.3	14.0
3450			7.46	7.84	8.21	8.58	8.94	9.64	10.3	11.0	11.6	12.2	13.2	14.1	14.7	15.2
100	0.17	0.20	0.22	0.24	0.25	0.26	0.27	0.30	0.32	0.35	0.37	0.40	0.45	0.50	0.55	0.60
200	0.35	0.40	0.45	0.47	0.50	0.52	0.55	0.60	0.65	0.70	0.75	0.80	0.90	1.00	1.10	1.20
300	0.52	0.60	0.67	0.71	0.75	0.79	0.82	0.90	0.97	1.05	1.12	1.20	1.34	1.49	1.64	1.79
400	0.70	0.80	0.90	0.95	1.00	1.05	1.10	1.20	1.30	1.39	1.49	1.59	1.79	1.99	2.19	2.39
500	0.87	1.00	1.12	1.18	1.25	1.31	1.37	1.49	1.62	1.74	1.87	1.99	2.24	2.48	2.73	2.98
600	1.05	1.20	1.34	1.42	1.49	1.57	1.64	1.79	1.94	2.09	2.24	2.39	2.68	2.98	3.27	3.56
700	1.22	1.39	1.57	1.66	1.74	1.83	1.92	2.09	2.26	2.43	2.61	2.78	3.12	3.46	3.80	4.14
800	1.39	1.59	1.79	1.89	1.99	2.09	2.19	2.39	2.58	2.78	2.98	3.17	3.56	3.95	4.34	4.72
900	1.57	1.79	2.01	2.13	2.24	2.35	2.46	2.68	2.90	3.12	3.34	3.56	4.00	4.43	4.86	5.29
1000	1.74	1.99	2.24	2.36	2.48	2.61	2.73	2.98	3.22	3.46	3.71	3.95	4.43	4.91	5.38	5.85
1100	1.92	2.19	2.46	2.59	2.73	2.87	3.00	3.27	3.54	3.80	4.07	4.34	4.86	5.38	5.90	6.41
1200		2.39	2.68	2.83	2.98	3.12	3.27	3.56	3.85	4.14	4.43	4.72	5.29	5.85	6.41	6.95
1300		2.58	2.90	3.06	3.22	3.38	3.54	3.85	4.17	4.48	4.79	5.10	5.71	6.31	6.91	7.49
1400		2.78	3.12	3.29	3.46	3.63	3.80	4.14	4.48	4.82	5.15	5.48	6.13	6.77	7.40	8.02
1500		2.98	3.34	3.53	3.71	3.89	4.07	4.43	4.79	5.15	5.50	5.85	6.54	7.22	7.88	8.53
1600		3.17	3.56	3.76	3.95	4.14	4.34	4.72	5.10	5.48	5.85	6.22	6.95	7.67	8.36	9.03
1700		3.37	3.78	3.99	4.19	4.40	4.60	5.01	5.41	5.81	6.20	6.59	7.36	8.10	8.83	9.52
1800		3.56	4.00	4.22	4.43	4.65	4.86	5.29	5.71	6.13	6.54	6.95	7.75	8.53	9.28	10.0
1900		3.76	4.22	4.44	4.67	4.90	5.12	5.57	6.01	6.45	6.88	7.31	8.15	8.95	9.72	10.5
2000		3.95	4.43	4.67	4.91	5.15	5.38	5.85	6.31	6.77	7.22	7.67	8.53	9.36	10.2	10.9
2100			4.65	4.90	5.15	5.40	5.64	6.13	6.61	7.09	7.56	8.02	8.91	9.76	10.6	11.3
2200			4.86	5.12	5.38	5.64	5.90	6.41	6.91	7.40	7.88	8.36	9.28	10.2	11.0	11.8
2300			5.08	5.35	5.62	5.89	6.15	6.68	7.20	7.71	8.21	8.70	9.64	10.5	11.4	12.2
2400			5.29	5.57	5.85	6.13	6.41	6.95	7.49	8.02	8.53	9.03	10.0	10.9	11.8	12.5
2500			5.50	5.79	6.08	6.37	6.66	7.22	7.78	8.32	8.85	9.36	10.3	11.3	12.1	12.9
2600			5.71	6.01	6.31	6.61	6.91	7.49	8.06	8.62	9.16	9.68	10.7	11.6	12.5	13.2
2800			6.13	6.45	6.77	7.09	7.40	8.02	8.62	9.20	9.76	10.3	11.3	12.3	13.1	13.9
3000			6.54	6.88	7.22	7.56	7.88	8.53	9.16	9.76	10.3	10.9	12.0	12.9	13.7	14.4
3200			6.95	7.31	7.67	8.02	8.36	9.03	9.68	10.3	10.9	11.5	12.5	13.5	14.2	14.8
3400			7.36	7.73	8.10	8.47	8.83	9.52	10.2	10.8	11.4	12.0	13.1	14.0	14.7	15.2
3600					8.53	8.91	9.28	10.0	10.7	11.3	12.0	12.5	13.6	14.4	15.0	15.4
3800					8.95	9.34	9.72	10.5	11.2	11.8	12.4	13.0	14.0	14.8	15.3	15.5
4000					9.36	9.76	10.2	10.9	11.6	12.3	12.9	13.5	14.4	15.1	15.4	15.5
4200					9.76	10.2	10.6	11.3	12.1	12.7	13.3	13.9	14.7	15.3	15.5	15.4
4400					10.2	10.6	11.0	11.8	12.5	13.1	13.7	14.2	15.0	15.4	15.5	15.1
4600					10.5	11.0	11.4	12.2	12.9	13.5	14.1	14.5	15.2	15.5	15.3	14.7
4800					10.9	11.3	11.8	12.5	13.2	13.9	14.4	14.8	15.4	15.5	15.1	14.1
5000					11.3	11.7	12.1	12.9	13.6	14.2	14.7	15.1	15.5	15.4	14.7	13.4
5200					11.6	12.1	12.5	13.2	13.9	14.5	14.9	15.2	15.5	15.2	14.2	
5400					12.0	12.4	12.8	13.6	14.2	14.7	15.1	15.4	15.5	14.9	13.6	
5600					12.3	12.7	13.1	13.9	14.5	14.9	15.3	15.5	15.4	14.5		
5800					12.6	13.0	13.4	14.1	14.7	15.1	15.4	15.5	15.2	14.0		
6000					12.9	13.3	13.7	14.4	14.9	15.3	15.5	15.5	14.9	13.4		

 Use this sprocket and rpm only if required to obtain speed ratio or to meet diameter limitations. See Engineering Section II-5, Sprocket Diameter—Speed, on page 138.

 Sprocket surface speeds over 6,500 fpm; special pulleys are required. See Engineering Section II-5, Sprocket Diameter—Speed, on page 138.

Horsepower Rating for 1.00 Inch Wide H Section Belt (0.500 Inch Pitch)

RPM of Faster Shaft	Rated Horsepower for Small Pulley (Number of Grooves and Pitch Diameter, Inches)															
	14L 2.228	16L 2.546	18L 2.865	19L 3.024	20L 3.183	21L 3.342	22L 3.501	24L 3.820	26L 4.138	28L 4.456	30L 4.775	32L 5.093	36L 5.730	40L 6.366	44L 7.003	48L 7.639
725	1.75	1.99	2.24	2.37	2.49	2.62	2.74	2.99	3.23	3.48	3.73	3.97	4.46	4.95	5.44	5.92
870	2.09	2.39	2.69	2.84	2.99	3.14	3.28	3.58	3.88	4.17	4.46	4.76	5.34	5.92	6.50	7.07
950	2.29	2.61	2.94	3.10	3.26	3.42	3.58	3.91	4.23	4.55	4.87	5.19	5.82	6.45	7.08	7.69
1160	2.79	3.18	3.58	3.78	3.97	4.17	4.37	4.76	5.15	5.54	5.92	6.31	7.07	7.82	8.57	9.30
1425		3.91	4.39	4.63	4.87	5.11	5.35	5.82	6.29	6.76	7.23	7.69	8.61	9.51	10.4	11.2
1750		4.78	5.37	5.66	5.95	6.24	6.53	7.11	7.68	8.24	8.80	9.35	10.4	11.5	12.5	13.5
2850			8.61	9.06	9.51	9.95	10.4	11.2	12.1	12.9	13.7	14.5	15.9	17.2	18.3	19.3
3450			10.3	10.8	11.3	11.8	12.3	13.3	14.3	15.1	16.0	16.8	18.2	19.4	20.4	21.0
100	0.24	0.28	0.31	0.33	0.34	0.36	0.38	0.41	0.45	0.48	0.52	0.55	0.62	0.69	0.76	0.83
200	0.48	0.55	0.62	0.65	0.69	0.72	0.76	0.83	0.89	0.96	1.03	1.10	1.24	1.38	1.51	1.65
300	0.72	0.83	0.93	0.98	1.03	1.08	1.14	1.24	1.34	1.45	1.55	1.65	1.86	2.06	2.27	2.47
400	0.96	1.10	1.24	1.31	1.38	1.45	1.51	1.65	1.79	1.93	2.06	2.20	2.47	2.75	3.02	3.29
500	1.20	1.38	1.55	1.63	1.72	1.81	1.89	2.06	2.23	2.41	2.58	2.75	3.09	3.43	3.77	4.11
600	1.45	1.65	1.86	1.96	2.06	2.17	2.27	2.47	2.68	2.88	3.09	3.29	3.70	4.11	4.51	4.92
700	1.69	1.93	2.17	2.29	2.41	2.53	2.65	2.88	3.12	3.36	3.60	3.84	4.31	4.78	5.25	5.72
800	1.93	2.20	2.47	2.61	2.75	2.88	3.02	3.29	3.57	3.84	4.11	4.38	4.92	5.46	5.99	6.52
900	2.17	2.47	2.78	2.94	3.09	3.24	3.40	3.70	4.01	4.31	4.62	4.92	5.52	6.12	6.72	7.30
1000	2.41	2.75	3.09	3.26	3.43	3.60	3.77	4.11	4.45	4.78	5.12	5.46	6.12	6.78	7.43	8.08
1100	2.65	3.02	3.40	3.58	3.77	3.96	4.14	4.51	4.89	5.25	5.62	5.99	6.72	7.43	8.15	8.85
1200		3.29	3.70	3.91	4.11	4.31	4.51	4.92	5.32	5.72	6.12	6.52	7.30	8.08	8.85	9.60
1300		3.57	4.01	4.23	4.45	4.67	4.89	5.32	5.76	6.19	6.62	7.04	7.89	8.72	9.54	10.3
1400		3.84	4.31	4.55	4.78	5.02	5.25	5.72	6.19	6.65	7.11	7.56	8.47	9.35	10.2	11.1
1500		4.11	4.62	4.87	5.12	5.37	5.62	6.12	6.62	7.11	7.60	8.08	9.04	9.97	10.9	11.8
1600		4.38	4.92	5.19	5.46	5.72	5.99	6.52	7.04	7.56	8.08	8.59	9.60	10.6	11.5	12.5
1700		4.65	5.22	5.51	5.79	6.07	6.35	6.91	7.47	8.02	8.56	9.10	10.2	11.2	12.2	13.2
1800		4.92	5.52	5.82	6.12	6.42	6.72	7.30	7.89	8.47	9.04	9.60	10.7	11.8	12.8	13.8
1900		5.19	5.82	6.14	6.45	6.76	7.08	7.69	8.31	8.91	9.51	10.1	11.2	12.4	13.4	14.5
2000		5.46	6.12	6.45	6.78	7.11	7.43	8.08	8.72	9.35	9.97	10.6	11.8	12.9	14.0	15.1
2100			6.42	6.76	7.11	7.45	7.79	8.47	9.13	9.79	10.4	11.1	12.3	13.5	14.6	15.7
2200			6.72	7.08	7.43	7.79	8.15	8.85	9.54	10.2	10.9	11.5	12.8	14.0	15.2	16.2
2300			7.01	7.39	7.76	8.13	8.50	9.23	9.94	10.6	11.3	12.0	13.3	14.6	15.7	16.8
2400			7.30	7.69	8.08	8.47	8.85	9.60	10.3	11.1	11.8	12.5	13.8	15.1	16.2	17.3
2500			7.60	8.00	8.40	8.80	9.19	9.97	10.7	11.5	12.2	12.9	14.3	15.6	16.7	17.8
2600			7.89	8.31	8.72	9.13	9.54	10.3	11.1	11.9	12.6	13.4	14.8	16.1	17.2	18.3
2800			8.47	8.91	9.35	9.79	10.2	11.1	11.9	12.7	13.5	14.2	15.7	17.0	18.1	19.1
3000			9.04	9.51	9.97	10.4	10.9	11.8	12.6	13.5	14.3	15.1	16.5	17.8	18.9	19.9
3200			9.60	10.1	10.6	11.1	11.5	12.5	13.4	14.2	15.1	15.9	17.3	18.6	19.6	20.5
3400			10.2	10.7	11.2	11.7	12.2	13.2	14.1	15.0	15.8	16.6	18.0	19.3	20.2	20.9
3600					11.8	12.3	12.8	13.8	14.8	15.7	16.5	17.3	18.7	19.9	20.7	21.2
3800					12.4	12.9	13.4	14.5	15.4	16.3	17.2	18.0	19.3	20.4	21.1	21.4
4000					12.9	13.5	14.0	15.1	16.1	17.0	17.8	18.6	19.9	20.8	21.3	21.4
4200					13.5	14.1	14.6	15.7	16.7	17.6	18.4	19.1	20.3	21.1	21.4	21.2
4400					14.0	14.6	15.2	16.2	17.2	18.1	18.9	19.6	20.7	21.3	21.4	20.8
4600					14.6	15.1	15.7	16.8	17.8	18.7	19.4	20.1	21.0	21.4	21.2	20.3
4800					15.1	15.7	16.2	17.3	18.3	19.1	19.9	20.5	21.2	21.4	20.8	19.5
5000					15.6	16.2	16.7	17.8	18.8	19.6	20.3	20.8	21.4	21.2	20.3	18.5
5200					16.1	16.7	17.2	18.3	19.2	20.0	20.6	21.1	21.4	21.0	19.6	
5400					16.5	17.1	17.7	18.7	19.6	20.3	20.9	21.2	21.4	20.6	18.8	
5600					17.0	17.6	18.1	19.1	20.0	20.6	21.1	21.4	21.2	20.0		
5800					17.4	18.0	18.5	19.5	20.3	20.9	21.3	21.4	20.9	19.4		
6000					17.8	18.4	18.9	19.9	20.6	21.1	21.4	21.4	20.6	18.5		

Use this sprocket and rpm only if required to obtain speed ratio or to meet diameter limitations. See Engineering Section II-5, Sprocket Diameter—Speed, on page 138.

Sprocket surface speeds over 6,500 fpm; special pulleys are required. See Engineering Section II-5, Sprocket Diameter—Speed, on page 138.



Horsepower Rating for 1.50 Inch Wide H Section Belt (0.500 Inch Pitch)

RPM of Faster Shaft	Rated Horsepower for Small Pulley (Number of Grooves and Pitch Diameter, Inches)															
	14L 2.228	16L 2.546	18L 2.865	19L 3.024	20L 3.183	21L 3.342	22L 3.501	24L 3.820	26L 4.138	28L 4.456	30L 4.775	32L 5.093	36L 5.730	40L 6.366	44L 7.003	48L 7.639
725	2.71	3.09	3.48	3.67	3.87	4.06	4.25	4.63	5.02	5.40	5.78	6.17	6.93	7.68	8.44	9.19
870	3.25	3.71	4.17	4.40	4.63	4.87	5.10	5.55	6.01	6.47	6.93	7.38	8.29	9.19	10.1	11.0
950	3.55	4.05	4.56	4.81	5.06	5.31	5.56	6.06	6.56	7.06	7.55	8.05	9.03	10.0	11.0	11.9
1160	4.33	4.94	5.55	5.86	6.17	6.47	6.77	7.38	7.99	8.59	9.19	9.79	11.0	12.1	13.3	14.4
1425		6.06	6.81	7.18	7.55	7.93	8.30	9.03	9.77	10.5	11.2	11.9	13.4	14.8	16.1	17.5
1750		7.42	8.34	8.79	9.24	9.69	10.1	11.0	11.9	12.8	13.7	14.5	16.2	17.8	19.4	20.9
2850			13.4	14.1	14.8	15.4	16.1	17.5	18.8	20.0	21.2	22.4	24.6	26.7	28.5	30.0
3450			16.0	16.8	17.6	18.4	19.2	20.7	22.1	23.5	24.8	26.1	28.3	30.1	31.6	32.6
100	0.37	0.43	0.48	0.51	0.53	0.56	0.59	0.64	0.69	0.75	0.80	0.85	0.96	1.07	1.18	1.28
200	0.75	0.85	0.96	1.01	1.07	1.12	1.18	1.28	1.39	1.50	1.60	1.71	1.92	2.14	2.35	2.56
300	1.12	1.28	1.44	1.52	1.60	1.68	1.76	1.92	2.08	2.24	2.40	2.56	2.88	3.20	3.52	3.84
400	1.50	1.71	1.92	2.03	2.14	2.24	2.35	2.56	2.78	2.99	3.20	3.41	3.84	4.26	4.69	5.11
500	1.87	2.14	2.40	2.54	2.67	2.80	2.94	3.20	3.47	3.73	4.00	4.26	4.79	5.32	5.85	6.38
600	2.24	2.56	2.88	3.04	3.20	3.36	3.52	3.84	4.16	4.48	4.79	5.11	5.74	6.38	7.01	7.63
700	2.62	2.99	3.36	3.55	3.73	3.92	4.10	4.48	4.85	5.22	5.59	5.96	6.69	7.42	8.15	8.88
800	2.99	3.41	3.84	4.05	4.26	4.48	4.69	5.11	5.53	5.96	6.38	6.80	7.63	8.46	9.29	10.1
900	3.36	3.84	4.32	4.56	4.79	5.03	5.27	5.74	6.22	6.69	7.16	7.63	8.57	9.50	10.4	11.3
1000	3.73	4.26	4.79	5.06	5.32	5.59	5.85	6.38	6.90	7.42	7.95	8.46	9.50	10.5	11.5	12.5
1100	4.10	4.69	5.27	5.56	5.85	6.14	6.43	7.01	7.58	8.15	8.72	9.29	10.4	11.5	12.6	13.7
1200		5.11	5.74	6.06	6.38	6.69	7.01	7.63	8.26	8.88	9.50	10.1	11.3	12.5	13.7	14.9
1300		5.53	6.22	6.56	6.90	7.24	7.58	8.26	8.93	9.60	10.3	10.9	12.2	13.5	14.8	16.0
1400		5.96	6.69	7.06	7.42	7.79	8.15	8.88	9.60	10.3	11.0	11.7	13.1	14.5	15.9	17.2
1500		6.38	7.16	7.55	7.95	8.34	8.72	9.50	10.3	11.0	11.8	12.5	14.0	15.5	16.9	18.3
1600		6.80	7.63	8.05	8.46	8.88	9.29	10.1	10.9	11.7	12.5	13.3	14.9	16.4	17.9	19.4
1700		7.21	8.10	8.54	8.98	9.42	9.86	10.7	11.6	12.4	13.3	14.1	15.8	17.4	18.9	20.4
1800		7.63	8.57	9.03	9.50	9.96	10.4	11.3	12.2	13.1	14.0	14.9	16.6	18.3	19.9	21.4
1900		8.05	9.03	9.52	10.0	10.5	11.0	11.9	12.9	13.8	14.8	15.7	17.5	19.2	20.8	22.4
2000		8.46	9.50	10.0	10.5	11.0	11.5	12.5	13.5	14.5	15.5	16.4	18.3	20.1	21.8	23.4
2100			9.96	10.5	11.0	11.6	12.1	13.1	14.2	15.2	16.2	17.2	19.1	20.9	22.7	24.3
2200			10.4	11.0	11.5	12.1	12.6	13.7	14.8	15.9	16.9	17.9	19.9	21.8	23.5	25.2
2300			10.9	11.5	12.0	12.6	13.2	14.3	15.4	16.5	17.6	18.6	20.7	22.6	24.4	26.1
2400			11.3	11.9	12.5	13.1	13.7	14.9	16.0	17.2	18.3	19.4	21.4	23.4	25.2	26.9
2500			11.8	12.4	13.0	13.7	14.3	15.5	16.7	17.8	19.0	20.1	22.2	24.2	26.0	27.6
2600			12.2	12.9	13.5	14.2	14.8	16.0	17.3	18.5	19.6	20.8	22.9	24.9	26.7	28.4
2800			13.1	13.8	14.5	15.2	15.9	17.2	18.5	19.7	20.9	22.1	24.3	26.3	28.1	29.7
3000			14.0	14.8	15.5	16.2	16.9	18.3	19.6	20.9	22.2	23.4	25.6	27.6	29.4	30.8
3200			14.9	15.7	16.4	17.2	17.9	19.4	20.8	22.1	23.4	24.6	26.9	28.8	30.5	31.8
3400			15.8	16.6	17.4	18.1	18.9	20.4	21.8	23.2	24.5	25.8	28.0	29.9	31.4	32.5
3600					18.3	19.1	19.9	21.4	22.9	24.3	25.6	26.9	29.1	30.8	32.1	33.0
3800					19.2	20.0	20.8	22.4	23.9	25.3	26.7	27.9	30.0	31.6	32.7	33.2
4000					20.1	20.9	21.8	23.4	24.9	26.3	27.6	28.8	30.8	32.3	33.1	33.2
4200					20.9	21.8	22.7	24.3	25.8	27.3	28.5	29.7	31.5	32.8	33.2	32.9
4400					21.8	22.7	23.5	25.2	26.7	28.1	29.4	30.5	32.1	33.1	33.2	32.3
4600					22.6	23.5	24.4	26.1	27.6	28.9	30.1	31.2	32.6	33.2	32.9	31.4
4800					23.4	24.3	25.2	26.9	28.4	29.7	30.8	31.8	33.0	33.2	32.3	30.3
5000					24.2	25.1	26.0	27.6	29.1	30.4	31.4	32.3	33.2	33.0	31.5	28.8
5200					24.9	25.8	26.7	28.4	29.8	31.0	32.0	32.7	33.2	32.5	30.5	
5400					25.6	26.6	27.4	29.1	30.4	31.5	32.4	33.0	33.1	31.9	29.2	
5600					26.3	27.3	28.1	29.7	31.0	32.0	32.8	33.2	32.9	31.1		
5800					27.0	27.9	28.8	30.3	31.5	32.4	33.0	33.2	32.5	30.0		
6000					27.6	28.5	29.4	30.8	32.0	32.8	33.2	33.2	31.9	28.8		

 Use this sprocket and rpm only if required to obtain speed ratio or to meet diameter limitations. See Engineering Section II-5, Sprocket Diameter—Speed, on page 138.

 Sprocket surface speeds over 6,500 fpm; special pulleys are required. See Engineering Section II-5, Sprocket Diameter—Speed, on page 138.

Horsepower Rating for 2.00 Inch Wide H Section Belt (0.500 Inch Pitch)

RPM of Faster Shaft	Rated Horsepower for Small Pulley (Number of Grooves and Pitch Diameter, Inches)															
	14L 2.228	16L 2.546	18L 2.865	19L 3.024	20L 3.183	21L 3.342	22L 3.501	24L 3.820	26L 4.138	28L 4.456	30L 4.775	32L 5.093	36L 5.730	40L 6.366	44L 7.003	48L 7.639
725	3.79	4.33	4.87	5.14	5.41	5.68	5.95	6.49	7.03	7.56	8.10	8.63	9.70	10.8	11.8	12.9
870	4.55	5.20	5.84	6.17	6.49	6.81	7.13	7.78	8.42	9.06	9.70	10.3	11.6	12.9	14.1	15.4
950	4.97	5.67	6.38	6.73	7.08	7.43	7.78	8.48	9.18	9.88	10.6	11.3	12.6	14.0	15.4	16.7
1160	6.06	6.92	7.78	8.20	8.63	9.06	9.48	10.3	11.2	12.0	12.9	13.7	15.4	17.0	18.6	20.2
1425		8.48	9.53	10.1	10.6	11.1	11.6	12.6	13.7	14.7	15.7	16.7	18.7	20.7	22.6	24.4
1750		10.4	11.7	12.3	12.9	13.6	14.2	15.4	16.7	17.9	19.1	20.3	22.7	25.0	27.2	29.3
2850			18.7	19.7	20.7	21.6	22.6	24.4	26.3	28.0	29.7	31.4	34.5	37.3	39.8	42.0
3450			22.4	23.5	24.6	25.7	26.8	28.9	31.0	32.9	34.7	36.5	39.6	42.2	44.2	45.7
100	0.52	0.60	0.67	0.71	0.75	0.79	0.82	0.90	0.97	1.05	1.12	1.20	1.35	1.50	1.65	1.79
200	1.05	1.20	1.35	1.42	1.50	1.57	1.65	1.79	1.94	2.09	2.24	2.39	2.69	2.99	3.29	3.59
300	1.57	1.79	2.02	2.13	2.24	2.36	2.47	2.69	2.92	3.14	3.36	3.59	4.03	4.48	4.93	5.37
400	2.09	2.39	2.69	2.84	2.99	3.14	3.29	3.59	3.89	4.18	4.48	4.78	5.37	5.97	6.56	7.16
500	2.62	2.99	3.36	3.55	3.74	3.92	4.11	4.48	4.85	5.23	5.60	5.97	6.71	7.45	8.19	8.93
600	3.14	3.59	4.03	4.26	4.48	4.71	4.93	5.37	5.82	6.27	6.71	7.16	8.04	8.93	9.81	10.7
700	3.66	4.18	4.71	4.97	5.23	5.49	5.75	6.27	6.79	7.30	7.82	8.34	9.37	10.4	11.4	12.4
800	4.18	4.78	5.37	5.67	5.97	6.27	6.56	7.16	7.75	8.34	8.93	9.51	10.7	11.9	13.0	14.2
900	4.71	5.37	6.04	6.38	6.71	7.04	7.38	8.04	8.71	9.37	10.0	10.7	12.0	13.3	14.6	15.9
1000	5.23	5.97	6.71	7.08	7.45	7.82	8.19	8.93	9.66	10.4	11.1	11.9	13.3	14.7	16.2	17.6
1100	5.75	6.56	7.38	7.78	8.19	8.60	9.00	9.81	10.6	11.4	12.2	13.0	14.6	16.2	17.7	19.2
1200		7.16	8.04	8.48	8.93	9.37	9.81	10.7	11.6	12.4	13.3	14.2	15.9	17.6	19.2	20.9
1300		7.75	8.71	9.18	9.66	10.1	10.6	11.6	12.5	13.4	14.4	15.3	17.1	18.9	20.7	22.5
1400		8.34	9.37	9.88	10.4	10.9	11.4	12.4	13.4	14.4	15.4	16.4	18.4	20.3	22.2	24.0
1500		8.93	10.0	10.6	11.1	11.7	12.2	13.3	14.4	15.4	16.5	17.6	19.6	21.7	23.7	25.6
1600		9.51	10.7	11.3	11.9	12.4	13.0	14.2	15.3	16.4	17.6	18.7	20.9	23.0	25.1	27.1
1700		10.1	11.3	12.0	12.6	13.2	13.8	15.0	16.2	17.4	18.6	19.8	22.1	24.3	26.5	28.6
1800		10.7	12.0	12.6	13.3	13.9	14.6	15.9	17.1	18.4	19.6	20.9	23.3	25.6	27.8	30.0
1900		11.3	12.6	13.3	14.0	14.7	15.4	16.7	18.0	19.4	20.7	21.9	24.4	26.9	29.2	31.4
2000		11.9	13.3	14.0	14.7	15.4	16.2	17.6	18.9	20.3	21.7	23.0	25.6	28.1	30.5	32.7
2100			13.9	14.7	15.4	16.2	16.9	18.4	19.8	21.3	22.7	24.0	26.7	29.3	31.7	34.0
2200			14.6	15.4	16.2	16.9	17.7	19.2	20.7	22.2	23.7	25.1	27.8	30.5	33.0	35.3
2300			15.2	16.0	16.9	17.7	18.5	20.0	21.6	23.1	24.6	26.1	28.9	31.6	34.1	36.5
2400			15.9	16.7	17.6	18.4	19.2	20.9	22.5	24.0	25.6	27.1	30.0	32.7	35.3	37.6
2500			16.5	17.4	18.3	19.1	20.0	21.7	23.3	25.0	26.5	28.1	31.0	33.8	36.4	38.7
2600			17.1	18.0	18.9	19.8	20.7	22.5	24.2	25.8	27.5	29.1	32.1	34.9	37.4	39.7
2800			18.4	19.4	20.3	21.3	22.2	24.0	25.8	27.6	29.3	30.9	34.0	36.9	39.4	41.6
3000			19.6	20.7	21.7	22.7	23.7	25.6	27.5	29.3	31.0	32.7	35.9	38.7	41.1	43.2
3200			20.9	21.9	23.0	24.0	25.1	27.1	29.1	30.9	32.7	34.5	37.6	40.4	42.7	44.5
3400			22.1	23.2	24.3	25.4	26.5	28.6	30.6	32.5	34.3	36.1	39.2	41.9	44.0	45.5
3600					25.6	26.7	27.8	30.0	32.1	34.0	35.9	37.6	40.7	43.2	45.0	46.1
3800					26.9	28.0	29.2	31.4	33.5	35.5	37.3	39.0	42.0	44.3	45.8	46.5
4000					28.1	29.3	30.5	32.7	34.9	36.9	38.7	40.4	43.2	45.2	46.3	46.5
4200					29.3	30.5	31.7	34.0	36.2	38.2	40.0	41.6	44.2	45.9	46.5	46.1
4400					30.5	31.7	33.0	35.3	37.4	39.4	41.1	42.7	45.0	46.3	46.4	45.3
4600					31.6	32.9	34.1	36.5	38.6	40.5	42.2	43.6	45.7	46.5	46.0	44.0
4800					32.7	34.0	35.3	37.6	39.7	41.6	43.2	44.5	46.1	46.5	45.3	42.4
5000					33.8	35.1	36.4	38.7	40.8	42.5	44.0	45.2	46.4	46.2	44.1	40.3
5200					34.9	36.2	37.4	39.7	41.7	43.4	44.7	45.7	46.5	45.6	42.7	
5400					35.9	37.2	38.4	40.7	42.6	44.2	45.4	46.1	46.4	44.7	40.8	
5600					36.9	38.2	39.4	41.6	43.4	44.8	45.9	46.4	46.1	43.5		
5800					37.8	39.1	40.3	42.4	44.1	45.4	46.2	46.5	45.5	42.0		
6000					38.7	40.0	41.1	43.2	44.7	45.9	46.4	46.5	44.7	40.3		

Use this sprocket and rpm only if required to obtain speed ratio or to meet diameter limitations. See Engineering Section II-5, Sprocket Diameter—Speed, on page 138.

Sprocket surface speeds over 6,500 fpm; special pulleys are required. See Engineering Section II-5, Sprocket Diameter—Speed, on page 138.



orsepower Rating for 3.00 Inch Wide H Section Belt (0.500 Inch Pitch)

RPM of Faster Shaft	Rated Horsepower for Small Pulley (Number of Grooves and Pitch Diameter, Inches)															
	14L 2.228	16L 2.546	18L 2.865	19L 3.024	20L 3.183	21L 3.342	22L 3.501	24L 3.820	26L 4.138	28L 4.456	30L 4.775	32L 5.093	36L 5.730	40L 6.366	44L 7.003	48L 7.639
725	6.02	6.88	7.73	8.16	8.59	9.02	9.45	10.3	11.2	12.0	12.9	13.7	15.4	17.1	18.8	20.4
870	7.22	8.25	9.27	9.79	10.3	10.8	11.3	12.3	13.4	14.4	15.4	16.4	18.4	20.4	22.4	24.4
950	7.88	9.00	10.1	10.7	11.2	11.8	12.4	13.5	14.6	15.7	16.8	17.9	20.1	22.2	24.4	26.5
1160	9.62	11.0	12.3	13.0	13.7	14.4	15.1	16.4	17.7	19.1	20.4	21.7	24.4	27.0	29.5	32.1
1425		13.5	15.1	16.0	16.8	17.6	18.4	20.1	21.7	23.3	24.9	26.5	29.7	32.8	35.8	38.8
1750		16.5	18.5	19.5	20.5	21.5	22.5	24.5	26.5	28.4	30.3	32.2	36.0	39.6	43.1	46.5
2850			29.7	31.2	32.8	34.3	35.8	38.8	41.7	44.5	47.2	49.8	54.8	59.3	63.2	66.7
3450			35.5	37.3	39.1	40.8	42.6	45.9	49.1	52.2	55.1	57.9	62.8	67.0	70.2	72.5
100	0.83	0.95	1.07	1.13	1.19	1.25	1.31	1.42	1.54	1.66	1.78	1.90	2.14	2.37	2.61	2.85
200	1.66	1.90	2.14	2.26	2.37	2.49	2.61	2.85	3.09	3.32	3.56	3.80	4.27	4.75	5.22	5.69
300	2.49	2.85	3.20	3.38	3.56	3.74	3.92	4.27	4.63	4.98	5.34	5.69	6.40	7.11	7.82	8.53
400	3.32	3.80	4.27	4.51	4.75	4.98	5.22	5.69	6.17	6.64	7.11	7.59	8.53	9.48	10.4	11.4
500	4.15	4.75	5.34	5.63	5.93	6.23	6.52	7.11	7.70	8.30	8.89	9.48	10.7	11.8	13.0	14.2
600	4.98	5.69	6.40	6.76	7.11	7.47	7.82	8.53	9.24	9.95	10.7	11.4	12.8	14.2	15.6	17.0
700	5.81	6.64	7.47	7.88	8.30	8.71	9.12	9.95	10.8	11.6	12.4	13.2	14.9	16.5	18.1	19.7
800	6.64	7.59	8.53	9.00	9.48	9.95	10.4	11.4	12.3	13.2	14.2	15.1	17.0	18.8	20.6	22.5
900	7.47	8.53	9.59	10.1	10.7	11.2	11.7	12.8	13.8	14.9	15.9	17.0	19.0	21.1	23.2	25.2
1000	8.30	9.48	10.7	11.2	11.8	12.4	13.0	14.2	15.3	16.5	17.7	18.8	21.1	23.4	25.6	27.9
1100	9.12	10.4	11.7	12.4	13.0	13.6	14.3	15.6	16.8	18.1	19.4	20.6	23.2	25.6	28.1	30.5
1200		11.4	12.8	13.5	14.2	14.9	15.6	17.0	18.3	19.7	21.1	22.5	25.2	27.9	30.5	33.1
1300		12.3	13.8	14.6	15.3	16.1	16.8	18.3	19.8	21.3	22.8	24.3	27.2	30.1	32.9	35.7
1400		13.2	14.9	15.7	16.5	17.3	18.1	19.7	21.3	22.9	24.5	26.1	29.2	32.2	35.2	38.2
1500		14.2	15.9	16.8	17.7	18.5	19.4	21.1	22.8	24.5	26.2	27.9	31.2	34.4	37.5	40.6
1600		15.1	17.0	17.9	18.8	19.7	20.6	22.5	24.3	26.1	27.9	29.6	33.1	36.5	39.8	43.0
1700		16.0	18.0	19.0	20.0	20.9	21.9	23.8	25.7	27.6	29.5	31.4	35.0	38.6	42.0	45.4
1800		17.0	19.0	20.1	21.1	22.1	23.2	25.2	27.2	29.2	31.2	33.1	36.9	40.6	44.2	47.6
1900		17.9	20.1	21.2	22.2	23.3	24.4	26.5	28.6	30.7	32.8	34.8	38.8	42.6	46.3	49.8
2000		18.8	21.1	22.2	23.4	24.5	25.6	27.9	30.1	32.2	34.4	36.5	40.6	44.6	48.4	52.0
2100			22.1	23.3	24.5	25.7	26.9	29.2	31.5	33.8	36.0	38.2	42.4	46.5	50.4	54.0
2200			23.2	24.4	25.6	26.9	28.1	30.5	32.9	35.2	37.5	39.8	44.2	48.4	52.3	56.0
2300			24.2	25.5	26.8	28.0	29.3	31.8	34.3	36.7	39.1	41.4	45.9	50.2	54.2	57.9
2400			25.2	26.5	27.9	29.2	30.5	33.1	35.7	38.2	40.6	43.0	47.6	52.0	56.0	59.7
2500			26.2	27.6	29.0	30.3	31.7	34.4	37.0	39.6	42.1	44.6	49.3	53.7	57.7	61.4
2600			27.2	28.6	30.1	31.5	32.9	35.7	38.4	41.0	43.6	46.1	50.9	55.3	59.4	63.0
2800			29.2	30.7	32.2	33.8	35.2	38.2	41.0	43.8	46.5	49.1	54.0	58.5	62.5	66.0
3000			31.2	32.8	34.4	36.0	37.5	40.6	43.6	46.5	49.3	52.0	57.0	61.4	65.3	68.5
3200			33.1	34.8	36.5	38.2	39.8	43.0	46.1	49.1	52.0	54.7	59.7	64.1	67.7	70.6
3400			35.0	36.8	38.6	40.3	42.0	45.4	48.6	51.6	54.5	57.3	62.2	66.4	69.8	72.2
3600					40.6	42.4	44.2	47.6	50.9	54.0	57.0	59.7	64.6	68.5	71.4	73.3
3800					42.6	44.5	46.3	49.8	53.2	56.3	59.3	62.0	66.7	70.3	72.7	73.8
4000					44.6	46.5	48.4	52.0	55.3	58.5	61.4	64.1	68.5	71.7	73.5	73.7
4200					46.5	48.5	50.4	54.0	57.4	60.6	63.4	66.0	70.1	72.8	73.8	73.1
4400					48.4	50.4	52.3	56.0	59.4	62.5	65.3	67.7	71.4	73.5	73.7	71.8
4600					50.2	52.2	54.2	57.9	61.3	64.3	67.0	69.3	72.5	73.8	73.0	69.9
4800					52.0	54.0	56.0	59.7	63.0	66.0	68.5	70.6	73.3	73.7	71.8	67.3
5000					53.7	55.8	57.7	61.4	64.7	67.5	69.9	71.7	73.7	73.3	70.1	63.9
5200					55.3	57.4	59.4	63.0	66.2	68.9	71.0	72.6	73.8	72.3	67.7	
5400					57.0	59.0	61.0	64.6	67.6	70.1	72.0	73.3	73.6	70.9	64.8	
5600					58.5	60.6	62.5	66.0	68.9	71.2	72.8	73.7	73.1	69.1		
5800					60.0	62.0	63.9	67.3	70.0	72.1	73.3	73.8	72.2	66.7		
6000					61.4	63.4	65.3	68.5	71.0	72.8	73.7	73.7	70.9	63.9		

 Use this sprocket and rpm only if required to obtain speed ratio or to meet diameter limitations. See Engineering Section II-5, Sprocket Diameter—Speed, on page 138.

 Sprocket surface speeds over 6,500 fpm; special pulleys are required. See Engineering Section II-5, Sprocket Diameter—Speed, on page 138.

Long Length Belting

Introduction

Long Length synchronous belting is a cost effective, low maintenance drive alternative that is especially suited for linear movement and positioning applications. Long Length belting is available in a wide variety of belt pitches and constructions. Applications as diverse as automated door openers, product conveying systems, positioning devices, and office equipment are possible using the different pitches and constructions available.

Long Length Belting Designations

PolyChain GT, PowerGrip, and Synchro-Power long length belting is specified using the same width and pitch codes as standard endless belts, except that the part designation includes an LL prefix and omits the length code. An ST suffix may also be used to indicate a steel tensile cord construction. For example, 8mm pitch PowerGrip GT belting, 50mm wide, with steel tensile cords, would be designated LL8MR50ST.

Long Length Belting Product Listing

Standard Long Length belting is available in 8mm and 14mm pitch Poly Chain® GT®; 2mm, 3mm, 5mm, and 8mm PowerGrip® GT®; 3mm, 5mm, 8mm, and 14mm PowerGrip® HTD®; MXL, XL, L, and H PowerGrip Timing; and T5, T10, AT5, and AT10 Synchro-Power® Polyurethane. Available standard and standard/non-stock Long Length belting is listed below.

Poly Chain GT Long Length Belting

8mm—14mm Pitch			
Part No.	Product No.	Width (mm)	Net Wt./ft. (lb)
LL8M012GT	9305-0001	12	0.03
LL8M021GT	9305-0002	21	0.06
LL8M036GT	9305-0003	36	0.11
LL14M020GT	9305-0005	20	0.10
LL14M037GT	9305-0006	37	0.19

PowerGrip GT—Long Length Belting

PowerGrip GT—Fiberglass Tensile

2mm—3mm—5mm—8mm Pitch			
Part No.	Product No.	Width (mm)	Net Wt./ft. (lb)
LL2MR04	9396-0033	4	0.01
LL2MR06	9396-0009	6	0.01
LL2MR09	9396-0011	9	0.01
LL3MR06	9396-0002	6	0.01
LL3MR09	9396-0012	9	0.01
LL3MR15	9396-0021	15	0.01
LL5MR09	9396-0020	9	0.01
LL5MR15	9396-0025	15	0.01
LL5MR25	9396-0018	25	0.05
LL8MR20	9396-0029	20	0.08
LL8MR30	9396-0030	30	0.13
LL8MR50	9396-0031	50	0.21
LL8MR85	9396-0032	85	0.36

PowerGrip GT—Steel Tensile

5mm—8mm Pitch			
Part No.	Product No.	Width (mm)	Net Wt./ft. (lb)
LL5MR15ST	9308-10043	15	0.18
LL5MR25ST	9308-40417	25	0.23
LL8MR20ST	9308-10049	20	0.29
LL8MR30ST	9308-10050	30	0.37
LL8MR50ST	9308-40433	50	0.53

PowerGrip HTD—Long Length Belting

PowerGrip HTD Belting—Fiberglass Tensile

3mm—5mm—8mm—14mm Pitch			
Part No.	Product No.	Width (mm)	Net Wt./ft. (lb)
LL3M06	9308-0044	6	0.01
LL3M09	9308-0003	9	0.01
LL3M15	9308-0084	15	0.01
LL5M09	9308-0045	9	0.01
LL5M15	9308-0033	15	0.01
LL5M25	9308-0025	25	0.05
LL8M20	9308-0001	20	0.08
LL8M30	9308-0004	30	0.13
LL8M50	9308-0005	50	0.21
LL8M85	9308-0006	85	0.36
LL14M40	9308-10009	40	0.26
LL14M55	9308-10020	55	0.35
LL14M85	9308-10057	85	0.55

PowerGrip HTD Belting—Steel Tensile

14mm Pitch			
Part No.	Product No.	Width (mm)	Net Wt./ft. (lb)
LL14M40ST	9308-10016	40	0.76
LL14M55ST	9308-10051	55	1.02
LL14M85ST	9308-10084	85	1.51

PowerGrip Timing—Long Length Belting

Mini-Pitch (0.080"/MXL)—Fiberglass Tensile			
Part No.	Product No.	Width (in)	Net Wt./ft. (lb)
LL025MXL	9314-2020	¼	0.01
LL037MXL	9314-2014	⅜	0.02
LL050MXL	9314-2038	½	0.02

1/5" Pitch (0.200"/XL)—Fiberglass Tensile			
Part No.	Product No.	Width (in)	Net Wt./ft. (lb)
LL025XL	9314-0001	¼	0.01
LL037XL	9314-0002	⅜	0.01
LL050XL	9314-2012	½	0.03
LL075XL	9314-2090	¾	0.04

1/5" Pitch (0.200"/XL)—Steel Tensile			
Part No.	Product No.	Width (in)	Net Wt./ft. (lb)
LL025XLST	9314-10028	¼	0.06
LL037XLST	9314-10029	⅜	0.07
LL050XLST	9314-10030	½	0.08

3/8" Pitch (0.375"/L)—Fiberglass Tensile			
Part No.	Product No.	Width (in)	Net Wt./ft. (lb)
LL037L	9314-2089	⅜	0.02
LL050L	9314-0004	½	0.02
LL075L	9314-0007	¾	0.04
LL100L	9314-0015	1	0.05

3/8" Pitch (0.375"/L)—Steel Tensile			
Part No.	Product No.	Width (in)	Net Wt./ft. (lb)
LL050LST	9314-10035	½	0.16
LL075LST	9314-10036	¾	0.19

1/2" Pitch (0.500"/H)—Fiberglass Tensile			
Part No.	Product No.	Width (in)	Net Wt./ft. (lb)
LL050H	9314-0003	½	0.04
LL075H	9314-0006	¾	0.06
LL100H	9314-0008	1	0.12
LL150H	9314-0017	1½	0.12
LL200H	9314-0021	2	0.16
LL300H	9314-0025	3	0.24

1/2" Pitch (0.500"/H)—Steel Tensile			
Part No.	Product No.	Width (in)	Net Wt./ft. (lb)
LL075HST	9314-10011	¾	0.22
LL100HST	9314-10037	1	0.25

Synchro-Power PolyUrethane Long Length Belting

T5 Pitch		
Part No.	Width (mm)	Net Wt./ft. (lb)
U6T5LL	6*	.01
U8T5LL	8	.01
U10T5LL	10*	.02
U12T5LL	12	.02
U16T5LL	16*	.03
U20T5LL	20	.03
U25T5LL	25*	.04
U32T5LL	32*	.05
U50T5LL	50*	.08

AT5 Pitch		
Part No.	Width (mm)	Net Wt./ft. (lb)
U6AT5LL	6*	.01
U10AT5LL	10*	.02
U16AT5LL	16*	.03
U20AT5LL	20*	.04
U25AT5LL	25*	.05
U32AT5LL	32*	.06
U50AT5LL	50*	.10

T10 Pitch		
Part No.	Width (mm)	Net Wt./ft. (lb)
U12T10LL	12	.04
U16T10LL	16*	.05
U20T10LL	20	.07
U25T10LL	25*	.08
U32T10LL	32*	.11
U40T10LL	40	.13
U50T10LL	50*	.16
U75T10LL	75*	.25
U100T10LL	100*	.33

AT10 Pitch		
Part No.	Width (mm)	Net Wt./ft. (lb)
U16AT10LL	16*	.06
U20AT10LL	20	.08
U25AT10LL	25*	.10
U32AT10LL	32*	.13
U40AT10LL	40	.16
U50AT10LL	50*	.20
U75AT10LL	75	.30
U100AT10LL	100	.40

T20 Pitch		
Part No.	Width (mm)	Net Wt./ft. (lb)
U25T20LL	25*	.13
U32T20LL	32*	.17
U50T20LL	50*	.27
U75T20LL	75*	.40
U100T20LL	100*	.54

AT20 Pitch		
Part No.	Width (mm)	Net Wt./ft. (lb)
U25AT20LL	25	.17
U32AT20LL	32	.22
U50AT20LL	50	.34
U75AT20LL	75	.50
U100AT20LL	100	.67
U120AT20LL	120*	.81
U150AT20LL	150*	1.01

*Stock size. All others are Standard/Non-Stock product.

Synchro-Power PolyUrethane Long Length Belting — continued

1/5" Pitch (0.200"/XL)		
Part No.	Width (mm)	Net Wt./ft. (lb)
U.25INXL LL	.250	.01
U.31INXL LL	.310	.01
U.375INXL LL	.375	.01
U.50INXL LL	.500	.02
U.75INXL LL	.750	.03
U1.00INXL LL	1.000	.03
U2.00INXL LL	2.000	.07

5mm Pitch HTD		
Part No.	Width (mm)	Net Wt./ft. (lb)
U10MTD5MLL	10	.03
U15MTD5MLL	15	.04
U25MTD5MLL	25	.07
U50MTD5MLL	50	.13

3/8" Pitch (0.375"/L)		
Part No.	Width (mm)	Net Wt./ft. (lb)
U.375INL LL	.375*	.02
U.50INL LL	.500*	.02
U.75INL LL	.750*	.03
U1.00INL LL	1.000*	.04
U1.50INL LL	1.500	.06
U2.00INL LL	2.000	.08

8mm Pitch HTD		
Part No.	Width (mm)	Net Wt./ft. (lb)
U10MTD8MLL	10	.04
U15MTD8MLL	15	.06
U20MTD8MLL	20	.08
U30MTD8MLL	30	.13
U50MTD8MLL	50	.21
U85MTD8MLL	85	.36
U100MTD8MLL	100	.42

1/2" Pitch (0.500"/H)		
Part No.	Width (mm)	Net Wt./ft. (lb)
U.50INH LL	.500*	.02
U.75INH LL	.750*	.04
U1.00INH LL	1.000*	.05
U1.50INH LL	1.500*	.07
U2.00INH LL	2.000*	.09
U3.00INH LL	3.000	.14
U4.00INH LL	4.000	.19

14mm Pitch HTD		
Part No.	Width (mm)	Net Wt./ft. (lb)
U25MTD14MLL	25	.19
U40MTD14MLL	40	.30
U55MTD14MLL	55	.41
U85MTD14MLL	85	.64
U100MTD14MLL	100	.75

7/8" Pitch (0.875"/XH)		
Part No.	Width (mm)	Net Wt./ft. (lb)
U1.00INXHLL	1.000	.22
U1.50INXHLL	1.500	.32
U2.00INXHLL	2.000	.43
U3.00INXHLL	3.000	.65
U4.00INXHLL	4.000	.86

*Stock size. All others are Standard/Non-Stock product.



Long Length Belting Specifications

The available standard pitches, with belt dimensions, constructions, and allowable working tensions (T_a), are shown below.

Poly Chain GT Belting

8mm Pitch—Aramid Tensile Cord

Belt Width (mm)	12	21	36
T_a (lb)	304	534	913

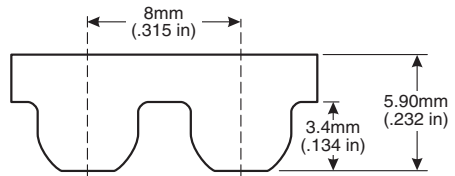

Poly Chain GT Belting

14mm Pitch - Aramid Tensile Cord

Belt Width (mm)	20	37
T_a (lb)	835	1545

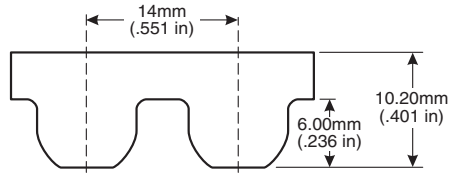

PowerGrip GT Belting

2MR Pitch - Fiberglass Tensile Cord

Belt Width (mm)	4	6	9
T_a (lb)	4.0	6.0	9.0

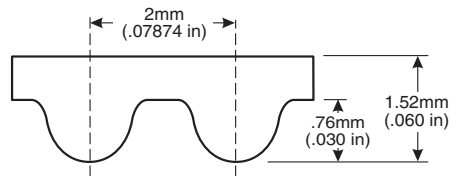

PowerGrip GT Belting

3MR Pitch - Fiberglass Tensile Cord

Belt Width (mm)	6	9	15
T_a (lb)	32.8	54.4	97.4

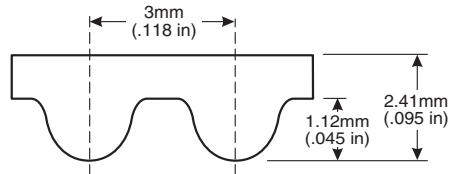

PowerGrip GT Belting

5MR Pitch - Fiberglass Tensile Cord

Belt Width (mm)	9	15	25
T_a (lb)	77.9	136.8	253.7

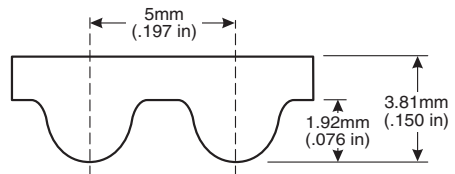

5MR Pitch - Steel Tensile Cord

Belt Width (mm)	15	25
T_a (lb)	184.9	342.8

PowerGrip GT Belting

8MR Pitch - Fiberglass Tensile Cord

Belt Width (mm)	20	30	50
T_a (lb)	190	216	552

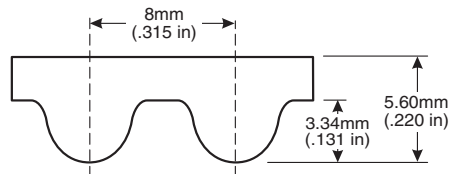

8MR Pitch - Steel Tensile Cord

Belt Width (mm)	20	30	50
T_a (lb)	369	579	1073

Long Length Belting Specifications — continued

PowerGrip HTD Belting

3M Pitch - Fiberglass Tensile Cord			
Belt Width (mm)	6	9	15
T _a (lb)	20.7	34.4	61.4

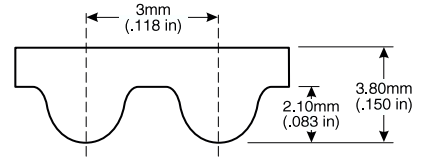

PowerGrip HTD Belting

5M Pitch - Fiberglass Tensile Cord			
Belt Width (mm)	9	15	25
T _a (lb)	55.6	97.6	181

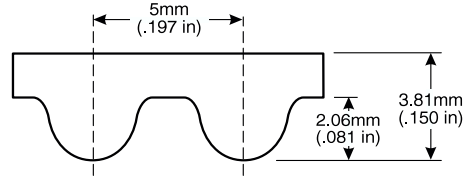

PowerGrip HTD Belting

8M Pitch - Fiberglass Tensile Cord			
Belt Width (mm)	20	30	50
T _a (lb)	190	216	552

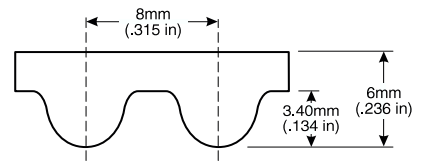

PowerGrip HTD Belting

14M Pitch - Fiberglass Tensile Cord			
Belt Width (mm)	40	55	85
T _a (lb)	909	1363	2263
14M Pitch - Steel Tensile Cord			
Belt Width (mm)	40	55	85
T _a (lb)	1227	1840	3055

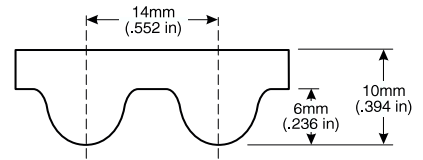

PowerGrip Timing Belting

XL Pitch - Fiberglass Tensile Cord			
Belt Width (in)	0.250	0.375	0.500
T _a (lb)	6.3	9.8	14.4
XL Pitch - Steel Tensile Cord			
Belt Width (in)	0.250	0.375	0.500
T _a (lb)	7.8	12.2	17.8

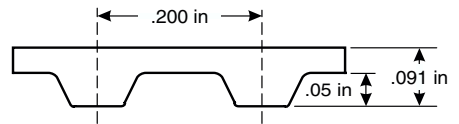

Long Length Belting Specifications — continued

PowerGrip Timing Belting

L Pitch - Fiberglass Tensile Cord

Belt Width (in)	0.375	0.500	0.750
T _a (lb)	15.7	24.7	35.9

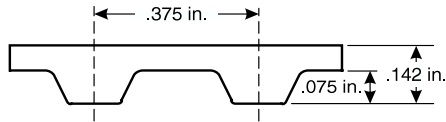

PowerGrip Timing Belting

H Pitch - Fiberglass Tensile Cord

Belt Width (in)	0.500	0.750	1.000
T _a (lb)	69.7	109.5	159.6

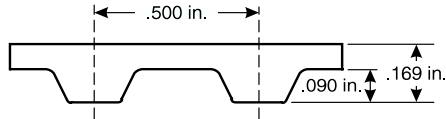

H Pitch - Steel Tensile Cord

Belt Width (in)	0.750	1.000
T _a (lb)	109.5	159.6

Synchro-Power Polyurethane Belting

AT5 Pitch - Steel Tensile Cord

Belt Width (mm)	6	10	16
T _a (lb)	130	137	236
Belt Width (mm)	25	32	50
T _a (lb)	389	499	792

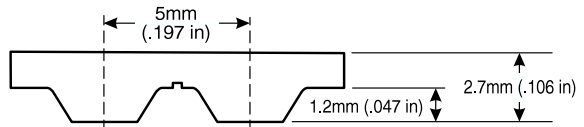

Synchro-Power Polyurethane Belting

AT10 Pitch - Steel Tensile Cord

Belt Width (mm)	16	25	32
T _a (lb)	517	819	1059
Belt Width (mm)	50	75*	100*
T _a (lb)	1696	2571	3397

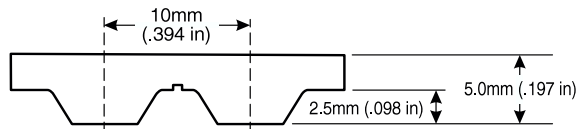

Synchro-Power Polyurethane Belting

T5 Pitch - Steel Tensile Cord			
Belt Width (mm)	6	10	16
T_a (lb)	36	63	105
Belt Width (mm)	25		32
T_a (lb)	175		225

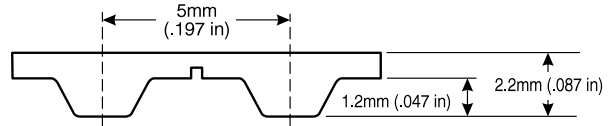

Synchro-Power Polyurethane Belting

T10 Pitch - Steel Tensile Cord			
Belt Width (mm)	16	25	32
T_a (lb)	258	418	558
Belt Width (mm)	50	75	100
T_a (lb)	859	1318	1759

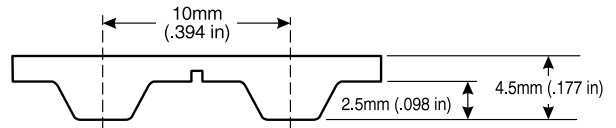

Synchro-Power Polyurethane Belting

L Pitch - Steel Tensile Cord			
Belt Width (in)	0.375	0.500	0.750
T_a (lb)	135	180	292
Belt Width (in)	1.000		1.500*
T_a (lb)	389		598

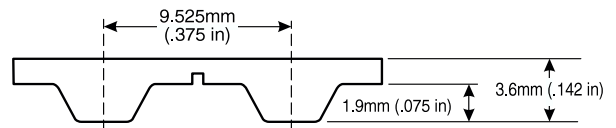

*Standard/Non-Stock belt width

Synchro-Power Polyurethane Belting

H Pitch - Steel Tensile Cord			
Belt Width (in)	0.500	0.750	1.000
T_a (lb)	198	319	441
Belt Width (in)	1.500		2.000
T_a (lb)	659		900

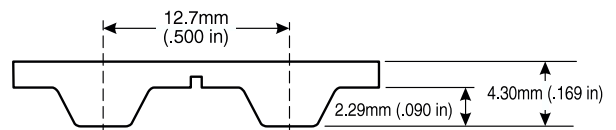

Drive Selection

Due to the unique nature of long length applications, special drive design procedures must be followed. Rather than designing a drive based on a single load at a continuous speed, long length application designs typically consider acceleration/deceleration loads generated by the mass being moved and placed, as well as the orientation of the drive (vertical or horizontal). Maximum dynamic drive tensions are then compared to allowable working tensions (T_a) for proper belt width selection. Considering the drive design procedures unique to Long Length belting applications, it is suggested that designers contact Gates Power Transmission Product Application for a drive system analysis.

Belt Clamping Fixtures

Long length applications typically require that the ends of the belt be mechanically fastened to the component being positioned. A common means of attachment is to use a belt clamping fixture, which clamps the ends of the belt between a grooved plate and a flat top plate. Belt clamping fixtures can have a variety of configurations, depending on belt pitch, belt tooth profile, and system attachment requirements. Contact Gates Power Transmission Product Application for groove dimensions that are suitable for use with clamping fixtures. A minimum of 6 belt teeth should be engaged in the belt clamping fixture to achieve optimum performance. As shown below, mechanical fasteners should be placed beyond the belt's top width in order to maintain belt integrity.

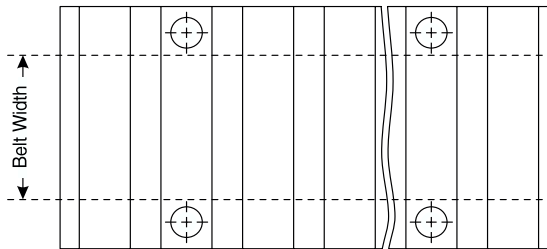

PowerGrip Twin Power Belts

Gates PowerGrip Twin Power Belts have teeth on both sides to provide synchronization from both driving surfaces. This configuration accommodates unique drive designs such as multipoint drives, shaft rotation reversal, and serpentine drives. Twin Power Belts are similar in construction to regular synchronous belts, including nylon-faced teeth on both sides.

Specifying Twin Power Belts

PowerGrip Twin Power Belts are specified using the same code as standard PowerGrip belts, except that they include a TP prefix. Thus, a Twin Power PowerGrip GT2 belt with 8mm pitch, 1600mm pitch length and 30mm width is specified as TP1600-8MGT-30. Similarly, a Twin Power PowerGrip Timing belt with an L pitch, 24" pitch length, and 1" width is specified as TP240L100. A listing of available sizes, both Stock and Standard/Non-Stock, is shown below. Standard/non-stock belts may require manufacturing lead time. Contact your local Gates representative for availability.

PowerGrip GT Twin Power belts are available in 3mm and 5mm pitches as non-stock, made to order items. Contact your Gates representative for availability.

Twin Power Drive Selection

Gates Twin Power Belts can transmit 100% of their maximum rated load capacity from either side of the belt or in combination where the sum of the loads carried by both sides of the belt does not exceed the maximum rating of the belt. For example, a Twin Power Belt rated at 12 HP could be used with 50% of the maximum rated load on one side and 50% on the other; or 90% on one side and 10% on the other.

8mm Pitch PowerGrip GT2 TwinPower Stock Belt Lengths

Part No.	Pitch Length		No. of Teeth
	(mm)	(in)	
TP840-8MGT	840	33.08	105
TP880-8MGT	880	34.65	110
TP920-8MGT	920	36.23	115
TP960-8MGT	960	37.80	120
TP1040-8MGT	1040	40.95	130
TP1120-8MGT	1120	44.10	140
TP1200-8MGT	1200	47.25	150
TP1224-8MGT	1224	48.20	153
TP1280-8MGT	1280	50.40	160
TP1440-8MGT	1440	56.70	180
TP1600-8MGT	1600	63.00	200

Part No.	Pitch Length		No. of Teeth
	(mm)	(in)	
TP1760-8MGT	1760	69.30	220
TP1800-8MGT	1800	70.88	225
TP2000-8MGT	2000	78.75	250
TP2200-8MGT	2200	86.63	275
TP2400-8MGT	2400	94.50	300
TP2600-8MGT	2600	102.38	325
TP2800-8MGT	2800	110.25	350
TP3048-8MGT	3048	120.02	381
TP3280-8MGT	3280	129.15	410
TP3600-8MGT	3600	141.75	450
TP4400-8MGT	4400	173.25	550

8M PowerGrip GT2 Twin Power — Reference Dimensions

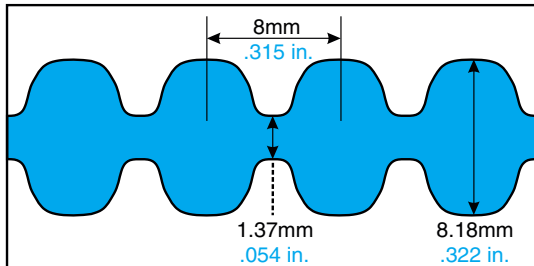

8M GT2 TwinPower Stock Belt Widths

Belt Width Code	Belt Width	
	(mm)	(in)
20	20	0.787
30	30	1.181
50	50	1.969
85	85	3.346



PowerGrip Twin Power Belts — continued

14mm Pitch PowerGrip GT2 TwinPower Stock Belt Lengths

Part No.	Pitch Length		No. of Teeth
	(mm)	(in)	
TP966-14MGT	966	38.03	69
TP1190-14MGT	1190	46.85	85
TP1400-14MGT	1400	55.12	100
TP1610-14MGT	1610	63.38	115
TP1778-14MGT	1778	70.00	127
TP1890-14MGT	1890	74.41	135
TP2100-14MGT	2100	82.67	150
TP2310-14MGT	2310	90.94	165
TP2450-14MGT	2450	96.45	175

Part No.	Pitch Length		No. of Teeth
	(mm)	(in)	
TP2590-14MGT	2590	101.96	185
TP2800-14MGT	2800	110.23	200
TP3150-14MGT	3150	124.01	225
TP3360-14MGT	3360	132.28	240
TP3500-14MGT	3500	137.79	250
TP3850-14MGT	3850	151.57	275
TP4326-14MGT	4326	170.31	309
TP4578-14MGT	4578	180.23	327

14M PowerGrip GT2 — Reference Dimensions

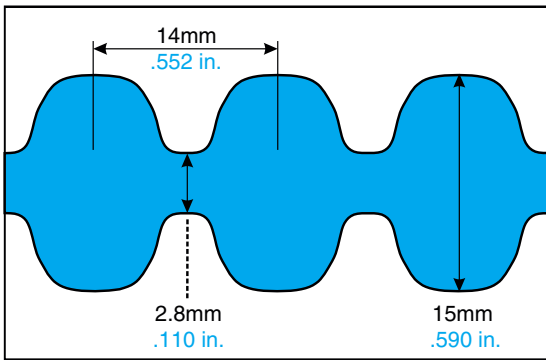

14MGT2 TwinPower Stock Belt Widths

Belt Width Code	Belt Width	
	(mm)	(in)
40	40	1.575
55	55	2.165
85	85	3.346
115	115	4.528
170	170	6.693

1/5" (0.200") Pitch XL PowerGrip TwinPower Timing Stock Belt Lengths

Part No.	Pitch Length (in)	No. of Teeth
TP140XL	14.00	70
TP150XL	15.00	75
TP160XL	16.00	80
TP170XL	17.00	85
TP180XL	18.00	90
TP190XL	19.00	95
TP200XL	20.00	100
TP210XL	21.00	105
TP220XL	22.00	110
TP230XL	23.00	115

Part No.	Pitch Length (in)	No. of Teeth
TP240XL	24.00	120
TP250XL	25.00	125
TP260XL	26.00	130
TP270XL	27.00	135
TP280XL	28.00	140
TP290XL	29.00	145
TP300XL	30.00	150
TP310XL	31.00	155
TP330XL	33.00	165
TP340XL	34.00	170

XL PowerGrip Twin Power — Reference Dimensions

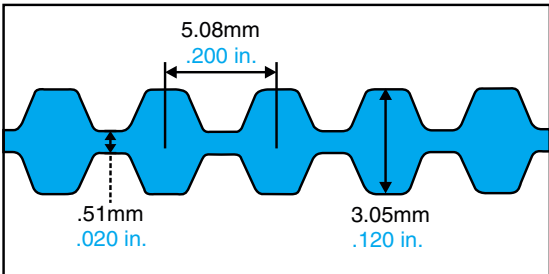

XL TwinPower Stock Belt Widths

Belt Width Code	Belt Width (in)
025	0.250
037	0.375

PowerGrip Twin Power Belts — continued

3/8" Pitch (0.375") Pitch L PowerGrip TwinPower Timing Stock Belt Lengths

Part No.	Pitch Length (in)	No. of Teeth
TP150L	15.00	40
TP165L	16.50	44
TP187L	18.75	50
TP195L	19.50	52
TP210L	21.00	56
TP225L	22.50	60
TP240L	24.00	64
TP255L	25.50	68
TP270L	27.00	72
TP285L	28.50	76
TP300L	30.00	80
TP322L	32.25	86

Part No.	Pitch Length (in)	No. of Teeth
TP345L	34.50	92
TP367L	36.75	98
TP390L	39.00	104
TP420L	42.00	112
TP450L	45.00	120
TP480L	48.00	128
TP510L	51.00	136
TP540L	54.00	144
TP600L	60.00	160
TP660L	66.00	176
TP817L	81.75	218

L PowerGrip Twin Power — Reference Dimensions

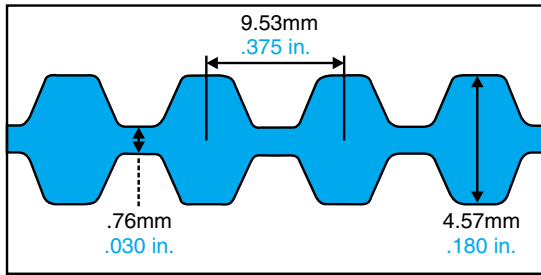

L TwinPower Stock Belt Widths

Belt Width Code	Belt Width (in)
050	0.500
075	0.750
100	1.000

1/2" (0.500") Pitch H PowerGrip TwinPower Timing Stock Belt Lengths

Part No.	Pitch Length (in)	No. of Teeth
TP240H	24.00	48
TP270H	27.00	54
TP300H	30.00	60
TP330H	33.00	66
TP350H	35.00	70
TP360H	36.00	72
TP390H	39.00	78
TP400H	40.00	80
TP420H	42.00	84
TP450H	45.00	90
TP480H	48.00	96
TP510H	51.00	102
TP540H	54.00	108
TP570H	57.00	114

Part No.	Pitch Length (in)	No. of Teeth
TP600H	60.00	120
TP630H	63.00	126
TP660H	66.00	132
TP700H	70.00	140
TP750H	75.00	150
TP800H	80.00	160
TP850H	85.00	170
TP900H	90.00	180
TP1000H	100.00	200
TP1100H	110.00	220
TP1250H	125.00	250
TP1400H	140.00	280
TP1700H	170.00	340

H PowerGrip Twin Power — Reference Dimensions

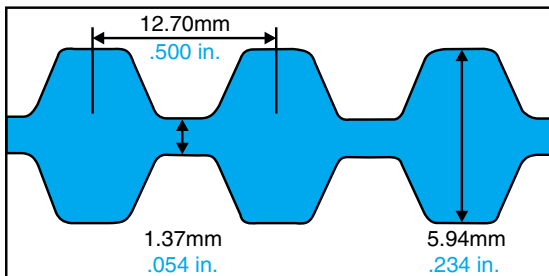

H TwinPower Stock Belt Widths

Belt Width Code	Belt Width (in)
075	0.750
100	1.000
150	1.500
200	2.000
300	3.000



PowerGrip® Twin Power® Belt Drive Selection Procedure

To select a Gates PowerGrip Twin Power Belt drive, you need to know only five facts:

1. DriveN horsepower requirements.
2. RPM of the driveR shaft.
3. RPM of the driveN shafts.
4. Approximate geometry for the drive.
5. Hours per day operation.

Step 1 Determine Design Horsepower

**Design Horsepower = (Service Factor) x
(Horsepower Requirement)**

- A. To calculate the design horsepower, it is necessary to determine the service factor for each type of driveN unit. Using the Service Factor Chart on Page 15, determine the type of driveR machine.
- B. Using this chart, determine the service factor for each driveN machine, based on the type of driveN machine and the type of service. Add any additional service factors required. Drives with multiple function driveN machines must have an appropriate service factor applied to each type of driveN machine.
- C. Multiply the horsepower requirement of the drive by the service factor selected. This yields the design horsepower for the drive.
- D. Add up the driveN loads. On multiple function driveN machines, add up the design horsepower for each driveN unit to determine the total horsepower for the drive.

Step 2 Select Belt Pitch

Locate the design horsepower along the bottom of the Belt Pitch Selection Guide on Page 11. Read up from the RPM of the smaller sprocket (faster shaft). The belt pitch indicated in the area surrounding the point of intersection is the one that should be used. If the point of intersection falls outside any specific area, contact your local Gates field representative. If the point is near one of the lines, a good drive can be designed with the belt pitch on either side of the line. Design drives using both belt pitches and select the most economical drive consistent with the other requirements.

Step 3 Select Sprockets and Determine Belt Length

A typical Twin Power Belt application will have three or more sprockets; although in some drives, one of the driveN sprockets may be unloaded and act only as an idler. It may be possible to use the Drive Selection Table as an aid to determine the required sprockets.

- A. For drives with standard motor speeds, refer to the appropriate motor speed column. Read down the column and locate the driveN machine speed nearest the requirements for each driveN sprocket using a common size motor sprocket.
- B. For all other speeds:
 1. Find the speed ratio by dividing the RPM of the faster shaft by the RPM of the slower shaft for each driveN sprocket in the drive.

2. Read down the speed ratio column and locate the speed ratio nearest the requirements. Select a driveN sprocket using a common size driveN sprocket which yields the speeds nearest the requirements.

C. Required belt lengths are most easily determined by measuring directly from a drawing of the drive layout. For computer aided assistance in determining the correct belt length, contact Gates Product Application Engineering.

Step 4 Calculate Horsepower Rating

A. For 8mm and 14mm pitch PowerGrip GT2 Twin Power Belts:

1. Determine Base HP Rating: Refer to the Belt Width Selection tables on page 46 for 20mm wide, 8mm pitch belts, and page 49 for 40mm wide, 14mm pitch belts. The tables present Horsepower Rating values for the narrowest, single sided belt width for each belt pitch. Read down the first column to the speed of the faster shaft, then across to the column headed by the smallest sprocket in the drive. The horsepower rating value shown is the Base Horsepower Rating.

2. Calculate Modified Twin Power HP Rating:

- a. For 20mm wide, 8mm pitch PowerGrip GT2 Twin Power belts, the Modified Twin Power Base Horsepower Rating is calculated by performing the calculation shown below.

20mm wide, 8mm pitch Twin Power:

$$\text{Modified Twin Power Horsepower Rating} = (\text{Table HP Rating}) - (d)(\text{RPM})(\text{TPf})$$

- b. For 40mm wide, 14mm pitch PowerGrip GT2 Twin Power belts, the Modified Twin Power Base Horsepower Rating is calculated by performing the simple calculation shown below.

40mm wide, 14mm pitch Twin Power:

$$\text{Modified Twin Power Horsepower Rating} = (\text{Table HP Rating}) - (d)(\text{RPM})(\text{TPf})$$

where d = pitch diameter of small sprocket, in.

RPM = RPM of small sprocket

TPf = Twin Power factor, based on belt pitch and width, selected from table below

Pitch	Belt Width (mm)	TPf
8M PowerGrip GT2 Twin Power	20	.000799
14M PowerGrip GT2 Twin Power	40	.00228

3. Calculate Final PowerGrip GT2 Twin Power HP Rating: To calculate the Final PowerGrip GT2 Twin Power Horsepower Rating for wider belt widths, multiply the Modified Twin Power Horsepower Rating by the appropriate Width Correction Factor shown below.

Pitch	Belt Width (mm)	Width Correction Factor
8M PowerGrip GT2 Twin Power	20	1.00
	30	1.57
	50	2.73
	85	4.75
14M PowerGrip GT2 Twin Power	40	1.00
	55	1.50
	85	2.50
	115	3.50
	170	5.32

PowerGrip® Twin Power® Belt Drive Selection Procedure

B. PowerGrip Timing Twin Power Belts: Belt Width Selection tables on pages 75 through 84 show the Horsepower Ratings for each stock belt width. Each table represents one belt width for a specific pitch belt. Read down the first column to the speed of the faster shaft, then across to the column headed by the small sprocket rotating at this speed. This value is the Horsepower Rating.

Step 5 Select Belt Width

A. Locate the critical sprocket in the drive. This sprocket may be either the smaller diameter sprocket or a larger diameter sprocket with less than six teeth in mesh, depending on the loads transmitted by each sprocket

1. Determine the number of teeth in mesh using the formula below:

$$\text{Teeth in Mesh} = \frac{\text{Angle of Sprocket Contact}}{360^\circ} \times \frac{\text{Number of Sprocket Teeth}}$$

2. Select the appropriate teeth in mesh factor (K_{tm}) from Page 135.
3. Correct the horsepower rating by multiplying the teeth in mesh factor (K_{tm}) by the horsepower rating from Step 4.

4. Repeat this procedure for each sprocket to locate the critical sprocket in the drive. Select the proper belt width on the basis of the critical sprocket parameters.

Step 6 Installation and Takeup

Because of its high resistance to elongation, there is no need to retension PowerGrip Twin Power Belt drives. However, some adjustments must be provided when installing timing belt drives, as with nearly all power transmission methods, because of manufacturing tolerances, wear of pressure surfaces and tensioning requirements. Center distance adjustment values are shown in the Center Distance Allowance Table on Page 141.

Step 7 Check and Specify Stock Drive Components

- A. Check the sprockets selected against the design requirements using the dimensions given in the Sprocket Specifications Tables on Pages 100 through 111.
- B. Using the Sprocket Specifications Tables, determine the **bushing size** to use with each sprocket. Check the **bore range** against the design requirements.
- C. Specify all stock components using proper designation for the belt, sprockets and bushings.

Gates PowerGrip® GT² Sprocket Specifications

For 5mm, 8mm, and 14mm PowerGrip GT2 Belts

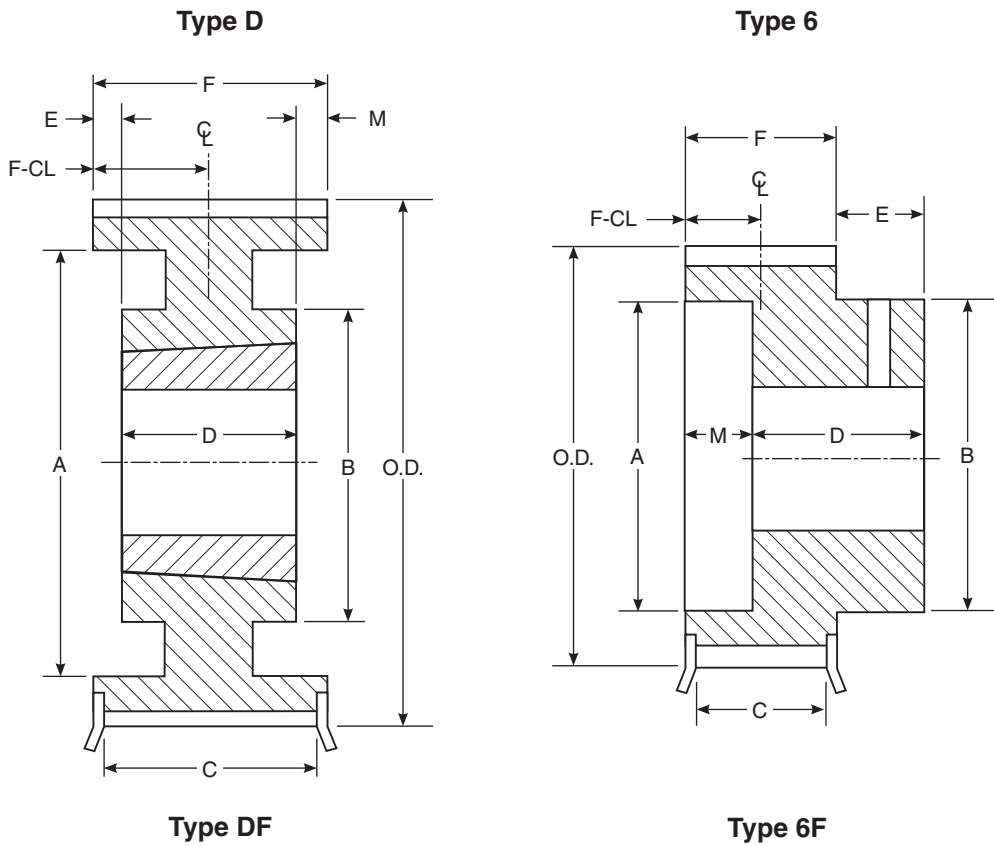
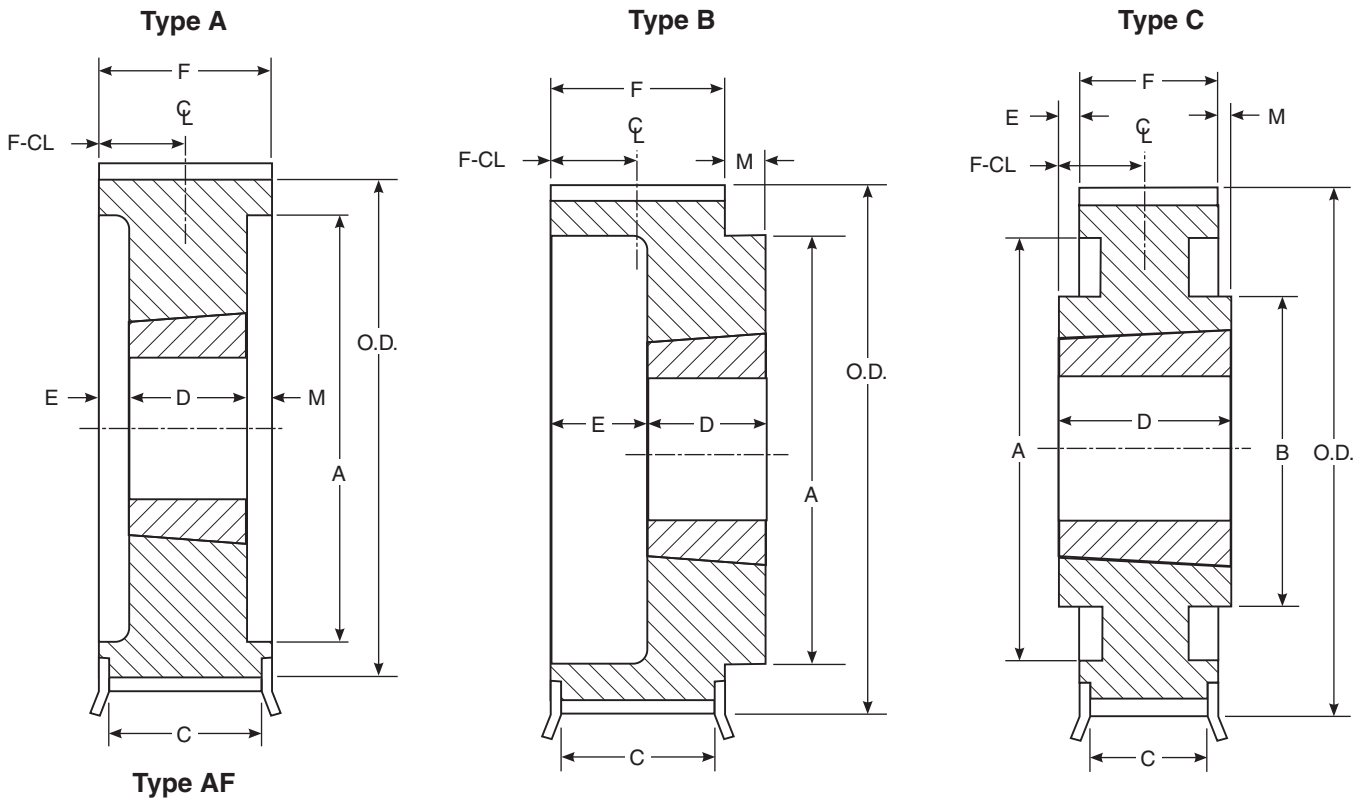

5mm Pitch PowerGrip GT2 Sprocket Specifications

Sprocket Number	Number of Teeth	Diameters (in)			Design Type	Dimensions (in)											Approx. Wt. (lb)	Approx. WR2	Matl. Spec.
		Pitch	O.D	Flange Ref.		A	B	C	D	E	F	M	F-CL	Bushing Size	Bore Sizes				
															Min.	Max.			
P18-5MGT-15 PB	18	1.128	1.083	1.385	6F-1	—	0.68	0.69	1.25	0.36	0.89	0	0.45	MPB	0.250	0.375	0.3	0.0003	S
P19-5MGT-15 PB	19	1.191	1.146	1.420	6F-1	—	0.88	0.69	1.25	0.36	0.89	0	0.45	MPB	0.250	0.437	0.3	0.0003	S
P20-5MGT-15 PB	20	1.253	1.208	1.510	6F-1	—	0.90	0.69	1.25	0.36	0.89	0	0.45	MPB	0.250	0.500	0.3	0.0004	S
P21-5MGT-15 PB	21	1.316	1.271	1.530	6F-1	—	1.09	0.69	1.25	0.36	0.89	0	0.45	MPB	0.250	0.690	0.4	0.0005	S
P22-5MGT-15 PB	22	1.379	1.334	1.530	6F-1	—	1.09	0.69	1.28	0.39	0.89	0	0.45	MPB	0.250	0.655	0.4	0.0006	S
P23-5MGT-15 PB	23	1.441	1.396	1.660	6F-1	—	1.15	0.69	1.28	0.39	0.89	0	0.45	MPB	0.375	0.625	0.5	0.0008	S
P24-5MGT-15 PB	24	1.504	1.459	1.780	6F-1	—	1.18	0.69	1.28	0.39	0.89	0	0.45	MPB	0.375	0.625	0.5	0.0009	S
P25-5MGT-15 PB	25	1.566	1.521	1.780	6F-1	—	1.18	0.69	1.28	0.39	0.89	0	0.45	MPB	0.375	0.625	0.6	0.001	S
P26-5MGT-15 PB	26	1.629	1.584	1.900	6F-1	—	1.21	0.69	1.28	0.39	0.89	0	0.45	MPB	0.375	0.687	0.6	0.001	S
P28-5MGT-15 PB	28	1.754	1.709	2.020	6F-1	—	1.37	0.69	1.34	0.45	0.89	0	0.45	MPB	0.500	0.750	0.7	0.001	S
P30-5MGT-15 PB	30	1.880	1.835	2.130	6F-1	—	1.53	0.69	1.34	0.45	0.89	0	0.45	MPB	0.500	0.937	0.8	0.002	S
P32-5MGT-15 PB	32	2.005	1.960	2.130	6F-1	—	1.55	0.69	1.34	0.45	0.89	0	0.45	MPB	0.500	0.937	0.9	0.002	S
P34-5MGT-15 PB	34	2.130	2.085	2.375	6F-1	—	1.69	0.69	1.34	0.45	0.89	0	0.45	MPB	0.500	1.000	1.1	0.003	S
P36-5MGT-15	36	2.256	2.211	2.380	AF-1	—	—	0.69	0.88	0	0.88	0	0.45	1108	0.500	1.125	0.5	0.002	SS
P36-5MGT-15 PB	36	2.256	2.211	2.380	6F-1	—	1.69	0.69	1.34	0.45	0.89	0	0.45	MPB	0.500	1.000	1.1	0.004	S
P38-5MGT-15	38	2.381	2.336	2.610	AF-1	—	—	0.69	0.88	0	0.88	0	0.45	1108	0.500	1.125	0.6	0.003	SS
P38-5MGT-15 PB	38	2.381	2.336	2.610	6F-1	—	1.96	0.69	1.34	0.45	0.89	0	0.45	MPB	0.500	1.250	1.6	0.005	S
P40-5MGT-15	40	2.506	2.461	2.730	AF-1	—	—	0.69	0.88	0	0.88	0	0.45	1108	0.500	1.125	0.7	0.004	SS
P40-5MGT-15 PB	40	2.506	2.461	2.730	6F-1	—	2.09	0.69	1.38	0.49	0.89	0	0.45	MPB	0.500	1.312	1.6	0.006	S
P44-5MGT-15	44	2.757	2.712	3.090	AF-1	—	—	0.69	0.88	0	0.88	0	0.45	1108	0.500	1.125	0.9	0.007	SS
P45-5MGT-15 PB	45	2.820	2.775	3.090	6F-1	—	2.34	0.69	1.38	0.49	0.89	0	0.45	MPB	0.500	1.500	2.1	0.010	S
P48-5MGT-15	48	3.008	2.963	3.330	BF-1	—	2.69	0.69	1.00	0	0.88	0.13	0.45	1210	0.500	1.250	0.0	0.010	SS
P50-5MGT-15 PB	50	3.133	3.088	3.330	6F-1	—	2.65	0.69	1.38	0.49	0.89	0	0.45	MPB	0.500	1.750	2.6	0.015	S
P52-5MGT-15	52	3.258	3.213	2.570	BF-1	—	2.88	0.69	1.00	0	0.88	0.13	0.45	1210	0.500	1.250	1.3	0.015	SS
P56-5MGT-15	56	3.509	3.464	3.810	BF-1	—	3.07	0.69	1.00	0	0.88	0.13	0.45	1610	0.500	1.688	1.4	0.019	SS
P60-5MGT-15	60	3.760	3.715	4.040	BF-1	—	3.25	0.69	1.00	0	0.88	0.13	0.45	1610	0.500	1.688	1.7	0.026	SS
P64-5MGT-15	64	4.010	3.965	4.140	BF-1	—	3.25	0.69	1.00	0	0.88	0.13	0.45	1610	0.500	1.688	2.1	0.035	SS
P68-5MGT-15	68	4.261	4.216	4.520	BF-1	—	3.25	0.69	1.00	0	0.88	0.13	0.45	1610	0.500	1.688	2.4	0.045	SS
P72-5MGT-15	72	4.511	4.466	4.670	BF-1	—	3.25	0.69	1.00	0	0.88	0.13	0.45	1610	0.500	1.688	2.8	0.058	SS
P80-5MGT-15	80	5.013	4.968	—	B-1	—	3.25	—	1.00	0	0.89	0.11	0.45	1610	0.500	1.688	3.7	0.090	SS
P90-5MGT-15	90	5.639	5.594	—	B-1	—	3.25	—	1.00	0	0.89	0.11	0.45	1610	0.500	1.688	4.9	0.147	SS
P112-5MGT-15	112	7.018	6.973	—	B-1	—	4.38	—	1.25	0	0.89	0.36	0.45	2012	0.500	2.125	8.3	0.374	SS

Material Spec : S - Steel SS - Sintered Steel G - Grey Iron D - Ductile Iron

Design Type Suffix: 1 - Solid 2 - Web 3 - Arms

Details shown which do not affect drive function may be changed without notification.



5mm Pitch PowerGrip GT2 Sprocket Specifications



Sprocket Number	Number of Teeth	Diameters (in)			Design Type	Dimensions (in)											Approx. Wt. (lb)	Approx. WR2	Matl. Spec.
		Pitch	O.D	Flange Ref.		A	B	C	D	E	F	M	F-CL	Bushing Size	Bore Sizes				
															Min.	Max.			
P18-5MGT-25 PB	18	1.128	1.083	1.385	6F-1	—	0.68	1.08	1.65	0.37	1.28	0	0.64	MPB	0.250	0.375	0.4	0.0003	S
P19-5MGT-25 PB	19	1.191	1.146	1.420	6F-1	—	0.88	1.08	1.65	0.37	1.28	0	0.64	MPB	0.250	0.437	0.4	0.0004	S
P20-5MGT-25 PB	20	1.253	1.208	1.510	6F-1	—	0.90	1.08	1.65	0.37	1.28	0	0.64	MPB	0.250	0.500	0.5	0.0005	S
P21-5MGT-25 PB	21	1.316	1.271	1.530	6F-1	—	1.09	1.08	1.65	0.37	1.28	0	0.64	MPB	0.250	0.690	0.5	0.0006	S
P22-5MGT-25 PB	22	1.379	1.334	1.530	6F-1	—	1.09	1.08	1.68	0.40	1.28	0	0.64	MPB	0.250	0.655	0.6	0.0007	S
P23-5MGT-25 PB	23	1.441	1.396	1.660	6F-1	—	1.15	1.08	1.68	0.40	1.28	0	0.64	MPB	0.375	0.625	0.7	0.0009	S
P24-5MGT-25 PB	24	1.504	1.459	1.780	6F-1	—	1.18	1.08	1.68	0.40	1.28	0	0.64	MPB	0.375	0.625	0.8	0.001	S
P25-5MGT-25 PB	25	1.566	1.521	1.780	6F-1	—	1.18	1.08	1.68	0.40	1.28	0	0.64	MPB	0.375	0.625	0.8	0.001	S
P26-5MGT-25 PB	26	1.629	1.584	1.900	6F-1	—	1.21	1.08	1.68	0.40	1.28	0	0.64	MPB	0.375	0.687	0.8	0.001	S
P28-5MGT-25 PB	28	1.754	1.709	2.020	6F-1	—	1.37	1.08	1.73	0.45	1.28	0	0.64	MPB	0.375	0.750	1.0	0.002	S
P30-5MGT-25 PB	30	1.880	1.835	2.130	6F-1	—	1.53	1.08	1.73	0.45	1.28	0	0.64	MPB	0.500	0.937	1.1	0.002	S
P32-5MGT-25 PB	32	2.005	1.960	2.125	6F-1	—	1.55	1.08	1.73	0.45	1.28	0	0.64	MPB	0.500	.937	1.2	0.003	S
P34-5MGT-25 PB	34	2.130	2.085	2.375	6F-1	—	1.69	1.08	1.73	0.45	1.28	0	0.64	MPB	0.500	1.000	1.4	0.004	S
P36-5MGT-25	36	2.256	2.211	2.375	AF-1	1.55	—	1.08	0.88	0	1.29	0.41	0.64	1108	0.500	1.125	0.7	0.003	SS
P36-5MGT-25 PB	36	2.256	2.211	2.380	6F-1	—	1.69	1.08	1.73	0.45	1.28	0	0.64	MPB	0.500	1.000	1.6	0.005	S
P38-5MGT-25	38	2.381	2.336	2.613	AF-1	1.80	—	1.08	0.88	0	1.29	0.41	0.64	1108	0.500	1.125	0.7	0.004	SS
P38-5MGT-25 PB	38	2.381	2.336	2.610	6F-1	—	1.96	1.08	1.73	0.45	1.28	0	0.64	MPB	0.500	1.250	1.9	0.007	S
P40-5MGT-25	40	2.506	2.461	2.733	AF-1	1.90	—	1.08	0.88	0	1.29	0.41	0.64	1108	0.500	1.125	0.8	0.006	SS
P40-5MGT-25 PB	40	2.506	2.461	2.730	6F-1	—	2.09	1.08	1.78	0.50	1.28	0	0.64	MPB	0.500	1.312	2.2	0.009	S
P44-5MGT-25	44	2.757	2.712	3.090	AF-1	2.20	—	1.08	0.88	0	1.29	0.41	0.64	1108	0.500	1.125	1.1	0.009	SS
P45-5MGT-25 PB	45	2.820	2.775	3.090	6F-1	—	2.34	1.08	1.78	0.50	1.28	0	0.64	MPB	0.500	1.500	2.7	0.014	S
P48-5MGT-25	48	3.008	2.963	3.328	AF-1	2.36	—	1.08	1.00	0	1.28	0.28	0.64	1210	0.500	1.250	1.2	0.012	SS
P50-5MGT-25 PB	50	3.133	3.088	3.330	6F-1	—	2.65	1.08	1.78	0.50	1.28	0	0.64	MPB	0.500	1.750	3.4	0.022	S
P52-5MGT-25	52	3.258	3.213	3.566	AF-1	2.62	—	1.08	1.00	0	1.28	0.28	0.64	1210	0.500	1.250	1.6	0.018	SS
P56-5MGT-25	56	3.509	3.464	3.805	AF-1	2.75	—	1.08	1.00	0	1.28	0.28	0.64	1610	0.500	1.688	1.6	0.024	SS
P60-5MGT-25	60	3.760	3.715	4.044	AF-1	2.90	—	1.08	1.00	0	1.28	0.28	0.64	1610	0.500	1.688	2.1	0.033	SS
P64-5MGT-25	64	4.010	3.965	4.170	AF-1	3.37	—	1.08	1.00	0	1.28	0.28	0.64	1610	0.500	1.688	2.4	0.042	G
P68-5MGT-25	68	4.261	4.216	4.520	AF-1	2.57	—	1.08	1.25	0.03	1.28	0	0.64	2012	0.500	2.125	2.7	0.057	G
P72-5MGT-25	72	4.511	4.466	4.670	AF-1	2.57	—	1.08	1.25	0.03	1.28	0	0.64	2012	0.500	2.125	3.3	0.075	G
P80-5MGT-25	80	5.013	4.968	—	A-1	2.57	—	1.08	1.25	0.03	1.28	0	0.64	2012	0.500	2.125	4.5	0.121	G
P90-5MGT-25	90	5.639	5.594	—	A-1	2.57	—	1.08	1.25	0.03	1.28	0	0.64	2012	0.500	2.125	6.2	0.203	G
P112-5MGT-25	112	7.018	6.973	—	A-1	2.57	—	1.08	1.25	0.03	1.28	0	0.64	2012	0.500	2.125	10.7	0.510	G

Material Spec : S - Steel SS - Sintered Steel G - Grey Iron D - Ductile Iron

Design Type Suffix: 1 - Solid 2 - Web 3 - Arms

Details shown which do not affect drive function may be changed without notification.

8mm Pitch PowerGrip GT2 Sprocket Specifications

Sprocket Number	Number of Teeth	Diameters (in)			Design Type	Dimensions (in)											Approx. Wt. (lb)	Approx. WR2	Matl. Spec.
		Pitch	O.D	Flange Ref.		A	B	C	D	E	F	M	F-CL	Bushing Size	Bore Sizes				
															Min.	Max.			
P22-8MGT-20	22	2.206	2.152	2.559	AF-1	1.55	—	0.85	0.88	0	1.14	0.26	0.56	1108	0.500	1.125	0.5	0.002	D
P24-8MGT-20	24	2.406	2.352	2.756	AF-1	1.55	—	0.85	0.88	0	1.14	0.26	0.56	1108	0.500	1.125	0.7	0.004	D
P26-8MGT-20	26	2.607	2.553	2.953	AF-1	1.55	—	0.85	0.88	0	1.14	0.26	0.56	1108	0.500	1.125	0.9	0.006	D
P28-8MGT-20	28	2.807	2.753	3.150	AF-1	1.10	—	0.85	0.88	0.26	1.14	0	0.56	1108	0.500	1.125	1.2	0.009	D
P30-8MGT-20	30	3.008	2.954	3.346	AF-1	1.20	—	0.85	1.00	0.13	1.13	0	0.56	1210	0.500	1.250	1.2	0.011	D
P32-8MGT-20	32	3.208	3.154	3.543	AF-1	1.91	—	0.85	1.00	0	1.13	0.13	0.56	1210	0.500	1.250	1.4	0.015	D
P34-8MGT-20	34	3.409	3.355	3.819	AF-1	1.60	—	0.85	1.00	0.13	1.13	0	0.56	1610	0.500	1.688	1.4	0.018	D
P36-8MGT-20	36	3.609	3.555	3.937	AF-1	1.60	—	0.85	1.00	0.13	1.13	0	0.56	1610	0.500	1.688	1.7	0.024	D
P38-8MGT-20	38	3.810	3.756	4.134	AF-1	1.60	—	0.85	1.00	0.13	1.13	0	0.56	1610	0.500	1.688	2.0	0.032	G
P40-8MGT-20	40	4.010	3.956	4.331	AF-1	1.60	—	0.85	1.00	0.13	1.13	0	0.56	1610	0.500	1.688	2.4	0.040	G
P44-8MGT-20	44	4.411	4.357	4.764	BF-1	—	3.88	0.85	1.25	0	1.12	0.13	0.56	2012	0.500	2.125	2.7	0.058	G
P48-8MGT-20	48	4.812	4.758	5.157	BF-1	—	4.25	0.85	1.25	0	1.12	0.13	0.56	2012	0.500	2.125	3.7	0.091	G
P56-8MGT-20	56	5.614	5.560	5.945	BF-1	—	4.38	0.85	1.25	0	1.12	0.13	0.56	2012	0.500	2.125	5.6	0.176	G
P64-8MGT-20	64	6.416	6.362	6.772	BF-1	—	4.38	0.85	1.25	0	1.12	0.13	0.56	2012	0.500	2.125	7.7	0.307	G
P72-8MGT-20	72	7.218	7.164	7.598	BF-1	—	4.38	0.85	1.25	0	1.12	0.13	0.56	2012	0.500	2.125	10.2	0.499	G
P80-8MGT-20	80	8.020	7.966	8.386	BF-1	—	4.88	0.85	1.75	0	1.12	0.63	0.56	2517	0.500	2.688	13.1	0.772	G
P90-8MGT-20	90	9.023	8.969	—	C-2	7.90	4.88	—	1.75	0.31	1.13	0.31	0.59	2517	0.500	2.688	12.5	0.903	G

Material Spec : S - Steel SS - Sintered Steel G - Grey Iron D - Ductile Iron

Design Type Suffix: 1 - Solid 2 - Web 3 - Arms

Details shown which do not affect drive function may be changed without notification.



8mm Pitch PowerGrip GT2 Sprocket Specifications



Sprocket Number	Number of Teeth	Diameters (in)			Design Type	Dimensions (in)											Approx. Wt. (lb)	Approx. WR2	Matl. Spec.
		Pitch	O.D	Flange Ref.		A	B	C	D	E	F	M	F-CL	Bushing Size	Bore Sizes				
															Min.	Max.			
P22-8MGT-30	22	2.206	2.152	2.559	AF-1	1.55	—	1.22	0.88	0	1.50	0.63	0.75	1108	0.500	1.125	0.6	0.003	D
P24-8MGT-30	24	2.406	2.352	2.756	AF-1	1.55	—	1.22	0.88	0	1.50	0.63	0.75	1108	0.500	1.125	0.9	0.005	D
P26-8MGT-30	26	2.607	2.553	2.953	AF-1	1.75	—	1.22	0.88	0	1.50	0.63	0.75	1108	0.500	1.125	1.1	0.008	D
P28-8MGT-30	28	2.807	2.753	3.150	AF-1	1.55	—	1.22	0.88	0	1.50	0.63	0.75	1108	0.500	1.125	1.5	0.012	G
P30-8MGT-30	30	3.008	2.954	3.346	AF-1	1.91	—	1.22	1.00	0	1.50	0.50	0.75	1210	0.500	1.250	1.5	0.015	D
P32-8MGT-30	32	3.208	3.154	3.543	AF-1	2.19	—	1.22	1.00	0	1.50	0.50	0.75	1210	0.500	1.250	1.7	0.019	D
P34-8MGT-30	34	3.409	3.355	3.819	AF-1	2.29	—	1.22	1.00	0	1.50	0.50	0.75	1610	0.500	1.688	1.8	0.024	D
P36-8MGT-30	36	3.609	3.555	3.937	AF-1	2.29	—	1.22	1.00	0	1.50	0.50	0.75	1610	0.500	1.688	2.2	0.032	D
P38-8MGT-30	38	3.810	3.756	4.134	AF-1	2.53	—	1.22	1.00	0	1.50	0.50	0.75	1610	0.500	1.688	2.5	0.040	D
P40-8MGT-30	40	4.010	3.956	4.331	AF-1	3.00	—	1.22	1.25	0	1.50	0.25	0.75	2012	0.500	2.125	2.3	0.045	G
P44-8MGT-30	44	4.411	4.357	4.764	AF-1	3.50	—	1.22	1.25	0	1.50	0.25	0.75	2012	0.500	2.125	3.2	0.071	G
P48-8MGT-30	48	4.812	4.758	5.157	AF-1	3.80	—	1.22	1.25	0	1.50	0.25	0.75	2012	0.500	2.125	4.2	0.106	G
P56-8MGT-30	56	5.614	5.560	5.945	AF-1	4.60	—	1.22	1.25	0	1.50	0.25	0.75	2012	0.500	2.125	6.3	0.208	G
P64-8MGT-30	64	6.416	6.362	6.772	BF-1	—	4.88	1.22	1.75	0	1.50	0.25	0.75	2517	0.500	2.688	9.5	0.404	G
P72-8MGT-30	72	7.218	7.164	7.598	BF-1	—	4.88	1.22	1.75	0	1.50	0.25	0.75	2517	0.500	2.688	12.8	0.659	G
P80-8MGT-30	80	8.020	7.966	8.386	BF-1	—	4.88	1.22	1.75	0	1.50	0.25	0.75	2517	0.500	2.688	16.5	1.019	G
P90-8MGT-30	90	9.023	8.969	—	C-2	7.90	4.88	—	1.75	0.13	1.50	0.12	0.51	2517	0.500	2.688	21.6	1.65	G
P112-8MGT-30	112	11.229	11.175	—	C-2	10.00	4.88	—	1.75	0.13	1.50	0.12	0.51	2517	0.500	2.688	25.4	3.42	G
P144-8MGT-30	144	14.437	14.383	—	C-2	13.20	4.88	—	1.88	0.38	1.50	0	0.76	2517	0.500	2.688	31.0	6.014	G

Material Spec : S - Steel SS - Sintered Steel G - Grey Iron D - Ductile Iron

Design Type Suffix: 1 - Solid 2 - Web 3 - Arms

Details shown which do not affect drive function may be changed without notification.

8mm Pitch PowerGrip GT2 Sprocket Specifications

Sprocket Number	Number of Teeth	Diameters (in)			Design Type	Dimensions (in)											Approx. Wt. (lb)	Approx. WR2	Matl. Spec.
		Pitch	O.D	Flange Ref.		A	B	C	D	E	F	M	F-CL	Bushing Size	Bore Sizes				
															Min.	Max.			
P28-8MGT-50 PB	28	2.807	2.753	3.207	6F-1	1.80	2.34	2.10	2.50	0.62	2.38	0.50	1.19	MPB	0.500	1.500	3.7	0.024	D
P30-8MGT-50	30	3.008	2.954	3.346	AF-1	2.00	—	2.10	1.00	0	2.38	1.38	1.19	1210	0.500	1.250	2.2	0.023	D
P32-8MGT-50	32	3.208	3.154	3.543	AF-1	2.36	—	2.10	1.00	0	2.38	1.38	1.19	1210	0.500	1.250	2.3	0.028	D
P34-8MGT-50	34	3.409	3.355	3.819	AF-1	2.57	—	2.10	1.00	0	2.38	1.38	1.19	1610	0.500	1.688	4.0	0.045	D
P36-8MGT-50	36	3.609	3.555	3.937	AF-1	2.77	—	2.10	1.00	0	2.38	1.38	1.19	1610	0.500	1.688	2.7	0.043	G
P38-8MGT-50	38	3.810	3.756	4.134	AF-1	2.97	—	2.10	1.00	0	2.38	1.38	1.19	1610	0.500	1.688	3.1	0.054	G
P40-8MGT-50	40	4.010	3.956	4.331	AF-1	2.97	—	2.10	1.25	0	2.38	1.13	1.19	2012	0.500	2.125	3.5	0.068	D
P44-8MGT-50	44	4.411	4.357	4.764	AF-1	3.50	—	2.10	1.25	0	2.38	1.13	1.19	2012	0.500	2.125	4.3	0.099	G
P48-8MGT-50	48	4.812	4.758	5.157	AF-1	3.80	—	2.10	1.25	0	2.38	1.13	1.19	2012	0.500	2.125	5.5	0.149	G
P56-8MGT-50	56	5.614	5.560	5.945	AF-1	4.60	—	2.10	1.75	0	2.38	0.63	1.19	2517	0.500	2.688	8.1	0.295	G
P64-8MGT-50	64	6.416	6.362	6.772	AF-1	5.40	—	2.10	1.75	0	2.38	0.63	1.19	2517	0.500	2.688	11.7	0.527	G
P72-8MGT-50	72	7.218	7.164	7.598	AF-1	6.20	—	2.10	1.75	0	2.38	0.63	1.19	2517	0.500	2.688	15.7	0.862	G
P80-8MGT-50	80	8.020	7.966	8.386	AF-1	6.90	—	2.10	1.75	0	2.38	0.63	1.19	2517	0.500	2.688	20.3	1.343	G
P90-8MGT-50	90	9.023	8.969	—	A-1	7.90	—	—	2.00	0	2.38	0.38	1.19	3020	0.875	3.250	26.9	2.277	G
P112-8MGT-50	112	11.229	11.175	—	A-2	10.00	—	—	2.00	0	2.38	0.38	1.19	3020	0.875	3.250	29.8	3.746	G
P144-8MGT-50	144	14.437	14.383	—	A-3	13.49	—	—	2.00	0	2.39	0.39	1.19	3020	0.875	3.250	49.0	8.988	D
P192-8MGT-50	192	19.249	19.195	—	A-3	18.00	—	—	2.00	0	2.38	0.38	1.19	3020	0.875	3.250	108.0	32.21	G

Material Spec : S - Steel SS - Sintered Steel G - Grey Iron D - Ductile Iron

Design Type Suffix: 1 - Solid 2 - Web 3 - Arms

Details shown which do not affect drive function may be changed without notification.



8mm Pitch PowerGrip GT2 Sprocket Specifications

Sprocket Number	Number of Teeth	Diameters (in)			Design Type	Dimensions (in)											Approx. Wt. (lb)	Approx. WR2	Matl. Spec.
		Pitch	O.D	Flange Ref.		A	B	C	D	E	F	M	F-CL	Bushing Size	Bore Sizes				
															Min.	Max.			
P34-8MGT-85	34	3.409	3.355	3.819	AF-1	2.52	—	3.47	1.50	0.75	3.75	1.50	1.88	1615	0.500	1.688	3.9	0.054	G
P36-8MGT-85	36	3.609	3.555	4.009	AF-1	2.72	—	3.47	1.50	0.75	3.75	1.50	1.88	1615	0.500	1.688	4.4	0.069	G
P38-8MGT-85	38	3.810	3.756	4.210	AF-1	3.00	—	3.47	1.00	0.63	2.75	1.12	2.50	1610	0.500	1.688	4.3	0.077	G
P40-8MGT-85	40	4.010	3.956	4.410	AF-1	3.12	—	3.47	1.25	1.25	3.75	1.25	1.88	2012	0.500	2.125	4.7	0.097	D
P44-8MGT-85	44	4.411	4.357	4.764	AF-1	3.50	—	3.47	1.25	1.25	3.75	1.25	1.88	2012	0.500	2.125	5.9	0.144	G
P48-8MGT-85	48	4.812	4.758	5.212	AF-1	3.80	—	3.47	1.25	1.25	3.75	1.25	1.88	2012	0.500	2.125	7.6	0.214	G
P56-8MGT-85	56	5.614	5.560	6.014	AF-1	4.60	—	3.47	1.75	0.81	3.75	1.19	1.88	2517	0.500	2.688	10.6	0.405	G
P64-8MGT-85	64	6.416	6.362	6.716	AF-1	5.40	—	3.47	1.75	0.59	3.75	1.41	1.88	2517	0.500	2.688	14.5	0.698	G
P72-8MGT-85	72	7.218	7.164	7.500	AF-1	6.20	—	3.47	2.00	0.88	3.76	0.88	1.88	3020	0.875	3.250	18.0	1.121	G
P80-8MGT-85	80	8.020	7.966	8.420	AF-1	7.20	—	3.47	2.00	0.50	3.75	1.25	1.88	3020	0.875	3.250	22.4	1.642	G
P90-8MGT-85	90	9.023	8.969	—	A-1	7.90	—	—	2.00	0.50	3.75	1.25	1.88	3020	0.875	3.250	31.5	2.846	G
P112-8MGT-85	112	11.229	11.175	—	D-1	10.00	6.25	—	2.00	0.50	3.75	1.25	1.44	3020	0.875	3.250	33.2	4.621	G
P144-8MGT-85	144	14.437	14.383	—	D-1	13.44	6.56	—	3.50	0	3.75	0.25	0.94	3535	1.188	3.938	54.1	11.06	G
P192-8MGT-85	192	19.249	19.195	—	D-1	18.00	7.00	—	3.50	0.13	3.76	0.13	1.07	3535	1.188	3.938	125.0	39.63	G

Material Spec : S - Steel SS - Sintered Steel G - Grey Iron D - Ductile Iron

Design Type Suffix: 1 - Solid 2 - Web 3 - Arms

Details shown which do not affect drive function may be changed without notification.



14mm Pitch PowerGrip GT2 Sprocket Specifications

Sprocket Number	Number of Teeth	Diameters (in)			Design Type	Dimensions (in)											Approx. Wt. (lb)	Approx. WR2	Matl. Spec.
		Pitch	O.D	Flange Ref.		A	B	C	D	E	F	M	F-CL	Bushing Size	Bore Sizes				
															Min.	Max.			
P28-14MGT-40	28	4.912	4.802	5.560	AF-1	3.13	—	1.81	1.25	0	2.13	0.88	1.06	2012	0.500	2.125	5.9	0.153	G
P29-14MGT-40	29	5.088	4.978	5.560	AF-1	3.15	—	1.81	1.25	0	2.13	0.88	1.06	2012	0.500	2.125	6.6	0.181	G
P30-14MGT-40	30	5.263	5.153	6.125	AF-1	3.85	—	1.81	1.25	0	2.13	0.88	1.06	2012	0.500	2.125	6.5	0.193	G
P32-14MGT-40	32	5.614	5.504	6.125	AF-1	3.92	—	1.81	1.25	0	2.13	0.88	1.06	2012	0.500	2.125	8.0	0.265	G
P34-14MGT-40	34	5.965	5.855	6.500	AF-1	4.06	—	1.81	1.25	0	2.13	0.88	1.06	2012	0.500	2.125	9.4	0.349	G
P36-14MGT-40	36	6.316	6.206	6.875	AF-1	4.69	—	1.81	1.75	0	2.13	0.38	1.06	2517	0.500	2.688	10.5	0.444	G
P38-14MGT-40	38	6.667	6.557	7.219	AF-1	4.94	—	1.81	1.75	0	2.13	0.38	1.06	2517	0.500	2.688	12.2	0.565	G
P40-14MGT-40	40	7.018	6.908	7.500	AF-1	5.06	—	1.81	1.75	0	2.13	0.38	1.06	2517	0.500	2.688	14.2	0.713	G
P44-14MGT-40	44	7.720	7.610	8.343	AF-1	6.14	—	1.81	1.75	0	2.13	0.38	1.06	2517	0.500	2.688	17.6	1.046	G
P48-14MGT-40	48	8.421	8.311	8.937	AF-1	6.50	—	1.81	1.75	0	2.13	0.38	1.06	2517	0.500	2.688	22.0	1.527	G
P52-14MGT-40	52	9.123	9.013	9.687	AF-1	7.18	—	1.81	1.75	0	2.13	0.38	1.06	2517	0.500	2.688	26.5	2.126	G
P56-14MGT-40	56	9.825	9.715	10.375	AF-1	7.88	—	1.81	1.75	0	2.13	0.38	1.06	2517	0.500	2.688	31.3	2.878	G
P60-14MGT-40	60	10.527	10.417	11.062	AF-1	8.50	—	1.81	2.00	0	2.13	0.13	1.06	3020	0.875	3.250	28.9	3.177	G
P64-14MGT-40	64	11.229	11.119	11.750	AF-1	9.25	—	1.81	2.00	0	2.13	0.13	1.06	3020	0.875	3.250	31.0	3.872	G
P68-14MGT-40	68	11.930	11.820	12.500	DF-1	10.00	6.25	1.81	2.00	0	2.13	0.13	0.53	3020	0.875	3.250	31.3	4.446	G
P72-14MGT-40	72	12.632	12.522	13.187	DF-1	10.69	6.25	1.81	2.00	0	2.13	0.13	0.53	3020	0.875	3.250	33.9	5.41	G
P80-14MGT-40	80	14.036	13.926	14.625	DF-3	12.53	5.50	1.81	2.00	0	2.13	0.13	0.53	3020	0.875	3.250	33.7	7.474	G
P90-14MGT-40	90	15.790	15.680	—	D-3	14.25	5.50	1.81	2.00	0	2.13	0.13	0.53	3020	0.875	3.250	39.7	9.396	G
P112-14MGT-40	112	19.650	19.540	—	A-3	18.09	—	—	2.00	0	2.13	0.13	1.06	3020	0.875	3.250	100.5	29.66	G
P144-14MGT-40	144	25.264	25.154	—	A-3	23.65	—	—	2.00	0	2.13	0.13	1.06	3020	0.875	3.250	154.1	75.16	G
P168-14MGT-40	168	29.475	29.365	—	A-3	27.50	—	—	2.00	0	2.13	0.13	1.06	3020	0.875	3.250	133.2	113.3	G
P192-14MGT-40	192	33.686	33.576	—	A-3	31.75	—	—	2.00	0	2.13	0.13	1.06	3020	0.875	3.250	167.6	189.8	G

Material Spec : S - Steel SS - Sintered Steel G - Grey Iron D - Ductile Iron

Design Type Suffix: 1 - Solid 2 - Web 3 - Arms

Details shown which do not affect drive function may be changed without notification.



14mm Pitch PowerGrip GT2 Sprocket Specifications



Sprocket Number	Number of Teeth	Diameters (in)			Design Type	Dimensions (in)											Approx. Wt. (lb)	Approx. WR2	Matl. Spec.
		Pitch	O.D	Flange Ref.		A	B	C	D	E	F	M	F-CL	Bushing Size	Bore Sizes				
															Min.	Max.			
P28-14MGT-55	28	4.912	4.802	5.560	AF-1	3.13	—	2.43	1.25	0	2.75	1.50	1.38	2012	0.500	2.125	7.4	0.194	G
P29-14MGT-55	29	5.088	4.978	5.560	AF-1	3.13	—	2.43	1.25	0	2.75	1.50	1.38	2012	0.500	2.125	8.4	0.231	G
P30-14MGT-55	30	5.263	5.153	6.125	AF-1	3.80	—	2.43	1.75	0	2.75	1.00	1.38	2517	0.500	2.688	7.4	0.237	G
P32-14MGT-55	32	5.614	5.504	6.125	AF-1	3.92	—	2.43	1.75	0	2.75	1.00	1.38	2517	0.500	2.688	9.3	0.327	G
P34-14MGT-55	34	5.965	5.855	6.500	AF-1	4.06	—	2.43	1.75	0	2.75	1.00	1.38	2517	0.500	2.688	11.2	0.437	G
P36-14MGT-55	36	6.316	6.206	6.875	AF-1	4.69	—	2.43	1.75	0	2.75	1.00	1.38	2517	0.500	2.688	12.4	0.54	G
P38-14MGT-55	38	6.669	6.557	7.219	AF-1	4.94	—	2.43	1.75	0	2.75	1.00	1.38	2517	0.500	2.688	14.4	0.686	G
P40-14MGT-55	40	7.018	6.908	7.500	AF-1	5.06	—	2.43	1.75	0	2.75	1.00	1.38	2517	0.500	2.688	16.7	0.871	G
P44-14MGT-55	44	7.720	7.610	8.343	AF-1	6.12	—	2.43	1.75	0	2.75	1.00	1.38	2517	0.500	2.688	19.9	1.234	G
P48-14MGT-55	48	8.421	8.311	8.937	AF-1	6.50	—	2.43	2.00	0	2.75	0.75	1.38	3020	0.875	3.250	24.4	1.84	G
P52-14MGT-55	52	9.123	9.013	9.687	AF-1	7.18	—	2.43	2.00	0	2.75	0.75	1.38	3020	0.875	3.250	29.6	2.573	G
P56-14MGT-55	56	9.825	9.715	10.375	AF-1	7.88	—	2.43	2.00	0	2.75	0.75	1.38	3020	0.875	3.250	35.3	3.489	G
P60-14MGT-55	60	10.527	10.417	11.062	AF-1	8.50	—	2.43	2.00	0	2.75	0.75	1.38	3020	0.875	3.250	41.6	4.647	G
P64-14MGT-55	64	11.229	11.119	11.750	AF-1	9.25	—	2.43	2.00	0	2.75	0.75	1.38	3020	0.875	3.250	47.9	6.012	G
P68-14MGT-55	68	11.930	11.820	12.500	DF-1	10.00	6.25	2.43	2.00	0	2.75	0.75	0.69	3020	0.875	3.250	40.2	5.909	G
P72-14MGT-55	72	12.632	12.522	13.187	DF-1	10.69	6.25	2.43	2.00	0	2.75	0.75	0.69	3020	0.875	3.250	45.1	7.387	G
P80-14MGT-55	80	14.036	13.926	14.625	DF-3	12.00	5.50	2.43	2.00	0	2.75	0.75	0.69	3020	0.875	3.250	41.6	9.021	G
P90-14MGT-55	90	15.790	15.680	—	D-3	14.22	5.50	—	2.00	0	2.75	0.75	0.69	3020	0.875	3.250	45.0	12.36	G
P112-14MGT-55	112	19.650	19.540	—	D-2	18.04	6.25	—	2.00	0	2.75	0.75	0.69	3020	0.875	3.250	116.7	36.86	G
P144-14MGT-55	144	25.264	25.154	—	D-3	23.38	6.25	—	2.00	0	2.75	0.75	0.69	3020	0.875	3.250	98.0	65.38	G
P168-14MGT-55	168	29.475	29.365	—	D-3	27.50	6.25	—	2.00	0.19	2.75	0.56	0.88	3020	0.875	3.250	145.5	150.2	G
P192-14MGT-55	192	33.686	33.576	—	C-3	31.93	6.56	—	3.50	0	2.75	0.75	0.69	3535	1.188	3.938	432.3	404.3	G

Material Spec : S - Steel SS - Sintered Steel G - Grey Iron D - Ductile Iron

Design Type Suffix: 1 - Solid 2 - Web 3 - Arms

Details shown which do not affect drive function may be changed without notification.

14mm Pitch PowerGrip GT2 Sprocket Specifications

Sprocket Number	Number of Teeth	Diameters (in)			Design Type	Dimensions (in)											Approx. Wt. (lb)	Approx. WR2	Matl. Spec.
		Pitch	O.D	Flange Ref.		A	B	C	D	E	F	M	F-CL	Bushing Size	Bore Sizes				
															Min.	Max.			
P28-14MGT-85	28	4.912	4.802	5.560	AF-1	3.13	—	3.68	1.25	1.31	4.00	1.44	2.00	2012	0.500	2.125	10.5	0.278	G
P29-14MGT-85	29	5.088	4.978	5.560	AF-1	3.13	—	3.68	1.25	1.31	4.00	1.44	2.00	2012	0.500	2.125	11.9	0.332	G
P30-14MGT-85	30	5.263	5.153	6.125	AF-1	3.78	—	3.68	1.75	0.50	4.00	1.75	2.00	2517	0.500	2.688	10.2	0.332	G
P32-14MGT-85	32	5.614	5.504	6.125	AF-1	3.92	—	3.68	1.75	0.81	4.00	1.44	2.00	2517	0.500	2.688	12.7	0.459	G
P34-14MGT-85	34	5.965	5.855	6.500	AF-1	4.06	—	3.68	1.75	0.81	4.00	1.44	2.00	2517	0.500	2.688	15.3	0.614	G
P36-14MGT-85	36	6.316	6.206	6.875	AF-1	4.69	—	3.68	2.00	0.53	4.00	1.47	2.00	3020	0.875	3.250	14.4	0.694	D
P38-14MGT-85	38	6.669	6.557	7.219	AF-1	4.94	—	3.68	2.00	0.53	4.00	1.47	2.00	3020	0.875	3.250	17.0	0.897	G
P40-14MGT-85	40	7.018	6.908	7.500	AF-1	5.06	—	3.68	2.00	0.53	4.00	1.47	2.00	3020	0.875	3.250	20.3	1.161	G
P44-14MGT-85	44	7.720	7.610	8.343	AF-1	6.12	—	3.68	2.00	0.53	4.00	1.47	2.00	3020	0.875	3.250	23.6	1.615	G
P48-14MGT-85	48	8.421	8.311	8.937	AF-1	6.50	—	3.68	2.00	0.53	4.00	1.47	2.00	3020	0.875	3.250	30.6	2.432	G
P52-14MGT-85	52	9.123	9.013	9.687	AF-1	7.18	—	3.68	3.50	0	4.00	0.50	2.00	3535	1.188	3.938	36.6	3.356	G
P56-14MGT-85	56	9.825	9.715	10.375	AF-1	7.88	—	3.68	3.50	0	4.00	0.50	2.00	3535	1.188	3.938	52.4	5.300	G
P60-14MGT-85	60	10.527	10.417	11.062	AF-1	8.50	—	3.68	3.50	0	4.00	0.50	2.00	3535	1.188	3.938	62.8	7.128	G
P64-14MGT-85	64	11.229	11.119	11.750	AF-1	9.25	—	3.68	3.50	0	4.00	0.50	2.00	3535	1.188	3.938	73.6	9.334	G
P68-14MGT-85	68	11.930	11.820	12.500	DF-1	10.00	7.00	3.68	3.50	0	4.00	0.50	1.00	3535	1.188	3.938	63.3	9.169	G
P72-14MGT-85	72	12.632	12.522	13.187	AF-1	10.69	—	3.68	3.50	0	4.00	0.50	2.00	3535	1.188	3.938	97.4	15.19	G
P80-14MGT-85	80	14.036	13.926	14.625	DF-2	12.13	7.00	3.68	3.50	0	4.00	0.50	1.00	3535	1.188	3.938	62.9	13.04	G
P90-14MGT-85	90	15.790	15.680	—	D-2	14.15	7.00	—	3.50	0	4.00	0.50	1.00	3535	1.188	3.938	71.5	18.14	G
P112-14MGT-85	112	19.650	19.540	—	D-3	17.97	6.56	—	3.50	0	4.00	0.50	1.00	3535	1.188	3.938	131.2	44.18	D
P144-14MGT-85	144	25.264	25.154	—	D-3	23.40	7.63	—	4.00	0	4.00	0	1.00	4040	1.438	4.438	137.4	92.1	G
P168-14MGT-85	168	29.475	29.365	—	D-3	27.70	7.63	—	4.00	0	4.00	0	1.00	4040	1.438	4.438	192.2	194.5	G
P192-14MGT-85	192	33.686	33.576	—	D-3	31.87	7.63	—	4.00	0	4.00	0	1.00	4040	1.438	4.438	448.0	444.6	G

Material Spec : S - Steel SS - Sintered Steel G - Grey Iron D - Ductile Iron

Design Type Suffix: 1 - Solid 2 - Web 3 - Arms

Details shown which do not affect drive function may be changed without notification.

14mm Pitch PowerGrip GT2 Sprocket Specifications



Sprocket Number	Number of Teeth	Diameters (in)			Design Type	Dimensions (in)											Approx. Wt. (lb)	Approx. WR2	Matl. Spec.
		Pitch	O.D	Flange Ref.		A	B	C	D	E	F	M	F-CL	Bushing Size	Bore Sizes				
															Min.	Max.			
P28-14MGT-115 PB	28	4.912	4.802	5.562	6F-1	3.13	3.69	4.93	5.00	1.20	5.30	1.50	2.67	MPB	1.250	2.688	22.2	0.508	D
P29-14MGT-115 PB	29	5.088	4.978	5.562	6F-1	3.13	3.69	4.93	5.00	1.20	5.30	1.50	2.67	MPB	1.250	2.688	24.0	0.585	D
P30-14MGT-115	30	5.263	5.153	5.763	AF-1	3.70	—	4.93	1.75	1.75	5.25	1.75	2.63	2517	0.500	2.688	13.4	0.438	G
P32-14MGT-115	32	5.614	5.504	6.114	AF-1	3.94	—	4.93	1.75	1.75	5.25	1.75	2.63	2517	0.500	2.688	16.0	0.587	G
P34-14MGT-115	34	5.965	5.855	6.465	AF-1	4.06	—	4.93	1.75	1.75	5.25	1.75	2.63	2517	0.500	2.688	19.5	0.790	G
P36-14MGT-115	36	6.316	6.206	6.816	AF-1	4.74	—	4.93	2.00	1.63	5.26	1.63	2.63	3020	0.875	3.250	17.9	0.876	G
P38-14MGT-115	38	6.669	6.557	7.167	AF-1	5.08	—	4.93	2.00	1.63	5.26	1.63	2.63	3020	0.875	3.250	20.3	1.100	G
P40-14MGT-115	40	7.018	6.908	7.518	AF-1	5.43	—	4.93	2.00	1.63	5.26	1.63	2.63	3020	0.875	3.250	22.9	1.357	G
P44-14MGT-115	44	7.720	7.610	8.395	AF-1	6.13	—	4.93	3.50	0.88	5.26	0.88	2.63	3535	1.188	3.938	30.3	2.144	G
P48-14MGT-115	48	8.421	8.311	8.941	AF-1	6.50	—	4.93	3.50	0.88	5.26	0.88	2.63	3535	1.188	3.938	40.3	3.277	G
P52-14MGT-115	52	9.123	9.013	9.687	AF-1	7.18	—	4.93	4.00	0.63	5.26	0.63	2.63	4040	1.438	4.438	46.8	4.545	G
P56-14MGT-115	56	9.825	9.715	10.355	AF-1	7.88	—	4.93	4.00	0.63	5.26	0.63	2.63	4040	1.438	4.438	58.1	6.335	G
P60-14MGT-115	60	10.527	10.417	11.067	AF-1	8.50	—	4.93	4.00	0.63	5.26	0.63	2.63	4040	1.438	4.438	70.4	8.589	G
P64-14MGT-115	64	11.229	11.119	11.750	AF-1	9.25	—	4.93	4.50	0.38	5.26	0.38	2.63	4545	1.938	4.938	82.4	11.47	G
P68-14MGT-115	68	11.930	11.820	12.500	AF-1	10.00	—	4.93	4.50	0.38	5.26	0.38	2.63	4545	1.938	4.938	97.2	14.91	G
P72-14MGT-115	72	12.632	12.522	13.066	AF-1	10.70	—	4.93	4.50	0.38	5.26	0.38	2.63	4545	1.938	4.938	113.2	19.06	G
P80-14MGT-115	80	14.036	13.926	14.620	AF-2	12.13	—	4.93	4.50	0.38	5.26	0.38	2.63	4545	1.938	4.938	147.5	29.66	G
P90-14MGT-115	90	15.790	15.680	—	D-1	14.11	9.50	—	4.50	0.38	5.26	0.38	2.32	4545	1.938	4.938	116.9	28.30	G
P112-14MGT-115	112	19.650	19.540	—	D-2	17.94	9.50	—	4.50	0	5.25	0.75	1.94	4545	1.938	4.938	173.3	64.72	G
P144-14MGT-115	144	25.264	25.154	—	D-3	9.50	17.94	—	4.50	0.38	5.26	0.38	2.32	4545	1.938	4.938	172.2	119.8	G
P168-14MGT-115	168	29.475	29.365	—	D-3	27.66	8.63	—	4.50	0.38	5.26	0.38	2.32	4545	1.938	4.938	223.4	243.3	G
P192-14MGT-115	192	33.686	33.576	—	D-2	31.83	8.63	—	4.50	0.38	5.26	0.38	2.32	4545	1.938	4.938	475.0	496.5	G
P216-14MGT-115	216	37.896	37.786	—	D-3	36.00	13.06	—	5.00	0	5.25	0.25	1.94	6050	4.438	6.000	378.0	686.1	G

Material Spec : S - Steel SS - Sintered Steel G - Grey Iron D - Ductile Iron

Design Type Suffix: 1 - Solid 2 - Web 3 - Arms

Details shown which do not affect drive function may be changed without notification.

14mm Pitch PowerGrip GT2 Sprocket Specifications

Sprocket Number	Number of Teeth	Diameters (in)			Design Type	Dimensions (in)											Approx. Wt. (lb)	Approx. WR2	Matl. Spec.
		Pitch	O.D	Flange Ref.		A	B	C	D	E	F	M	F-CL	Bushing Size	Bore Sizes				
															Min.	Max.			
P36-14MGT-170 PB	36	6.316	6.206	6.816	6F-1	4.69	5.00	7.06	6.00	1.21	7.42	2.63	3.73	MPB	1.500	3.375	47.3	1.849	D
P38-14MGT-170 PB	38	6.667	6.557	7.167	6F-1	4.94	5.38	7.06	6.00	1.21	7.42	2.63	3.73	MPB	1.500	3.375	53.5	2.321	D
P40-14MGT-170	40	7.018	6.908	7.518	AF-1	5.54	—	7.06	3.50	1.94	7.38	1.94	4.94	3535	1.188	3.938	28.6	1.780	G
P44-14MGT-170	44	7.720	7.610	8.395	AF-1	6.06	—	7.06	3.50	1.94	7.38	1.94	3.69	3535	1.188	3.938	38.9	2.828	G
P48-14MGT-170	48	8.421	8.311	8.941	AF-1	6.50	—	7.06	3.50	1.94	7.38	1.94	3.69	3535	1.188	3.938	51.0	4.283	G
P52-14MGT-170	52	9.123	9.013	9.687	AF-1	7.18	—	7.06	4.00	1.13	7.38	2.25	3.69	4040	1.438	4.438	58.6	5.877	G
P56-14MGT-170	56	9.825	9.715	10.355	AF-1	7.88	—	7.06	4.00	1.13	7.38	2.25	3.69	4040	1.438	4.438	70.9	8.051	G
P60-14MGT-170	60	10.527	10.417	11.067	AF-1	8.50	—	7.06	4.50	0.75	7.38	2.13	3.69	4545	1.938	4.938	82.9	10.85	G
P64-14MGT-170	64	11.229	11.119	11.750	AF-1	9.53	—	7.06	4.50	0.63	7.38	2.25	3.69	4545	1.938	4.938	94.5	13.71	G
P68-14MGT-170	68	11.930	11.820	12.500	AF-1	10.00	—	7.06	4.50	0.63	7.38	2.25	3.69	4545	1.938	4.938	113.0	18.15	G
P72-14MGT-170	72	12.632	12.522	13.066	AF-1	10.69	—	7.06	4.50	0.63	7.38	2.25	3.69	4545	1.938	4.938	130.1	23.00	G
P80-14MGT-170	80	14.036	13.926	14.625	AF-1	12.13	—	7.06	4.50	1.04	7.38	1.84	3.69	4545	1.938	4.938	166.2	35.12	G
P90-14MGT-170	90	15.790	15.680	—	D-1	14.05	9.00	—	4.50	0.63	7.38	2.25	3.10	4545	1.938	4.938	159.2	42.03	G
P112-14MGT-170	112	19.650	19.540	—	D-1	17.87	11.39	—	4.50	0	7.63	3.13	2.47	4545	1.938	4.938	215.1	81.3	G
P144-14MGT-170	144	25.264	25.154	—	D-3	23.31	13.02	—	5.00	1.19	7.38	1.19	3.66	6050	4.438	6.000	264.0	207.9	G
P168-14MGT-170	168	29.475	29.365	—	D-2	27.59	13.02	—	5.00	1.19	7.38	1.19	3.66	6050	4.438	6.000	462.0	384.2	G
P192-14MGT-170	192	33.686	33.576	—	D-3	31.76	13.02	—	5.00	1.19	7.38	1.19	3.66	6050	4.438	6.000	616.0	655.7	G
P216-14MGT-170	216	37.896	37.786	—	D-2	35.93	13.02	—	5.00	1.19	7.38	1.19	3.66	6050	4.438	6.000	563.0	851.7	D

Material Spec : S - Steel SS - Sintered Steel G - Grey Iron D - Ductile Iron

Design Type Suffix: 1 - Solid 2 - Web 3 - Arms

Details shown which do not affect drive function may be changed without notification.



Gates PowerGrip HTD® Sprocket Specifications

For 20mm Pitch PowerGrip GT2 Belts

Type A

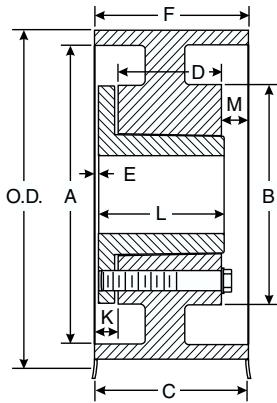

Type D

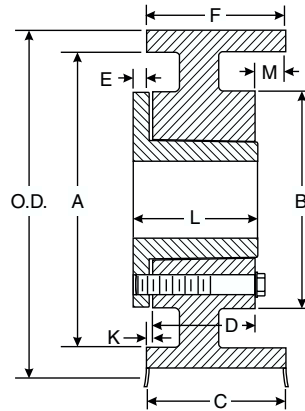

Type G

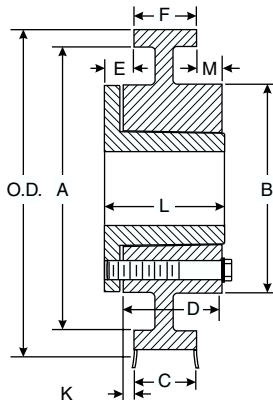

Bushing Mounting

QD Bushing Types M - S
mount in a
Conventional manner only.

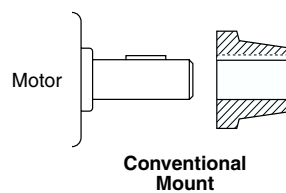
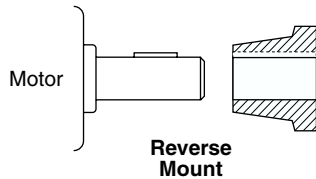

Sprocket Specification Tables

20mm Pitch HTD® Stock Sprockets

115mm (4.53 in) Wide Belts (20M-115)																				
Sprocket Code Symbol	Q. D. Bores	No. of Teeth	Diameters (Inches)			Type	Dimensions (in)								Bore Sizes		Approx. Weight† (lb)	Approx. WR ²	Mat'l Spec.	
			Pitch	O. D.	Flange		A	B	C	D	E	F	K	L	M	Min.				Max.
P34-20M-115	F	34	8.522	8.352	9 ⁷ / ₁₆	A-1	6 ³ / ₄	0	5	2 ¹ / ₂	¹ / ₁₆	5 ³ / ₈	1 ¹ / ₁₆	3 ³ / ₄	1 ¹ / ₁₆	1	4	36.5	2.820	G
P36-20M-115	F	36	9.023	8.853	9 ⁹ / ₃₂	A-1	6 ¹³ / ₁₆	0	5	2 ¹ / ₂	¹ / ₁₆	5 ³ / ₈	1 ¹ / ₁₆	3 ³ / ₄	1 ¹ / ₁₆	1	4	46.3	3.881	G
P38-20M-115	F	38	9.524	9.354	10 ¹ / ₁₆	A-1	7 ¹ / ₁₆	0	5	2 ¹ / ₂	¹ / ₁₆	5 ³ / ₈	1 ¹ / ₁₆	3 ³ / ₄	1 ¹ / ₁₆	1	4	51.0	4.833	G
P40-20M-115	F	40	10.026	9.855	10 ³ / ₁₆	A-1	7 ⁷ / ₈	0	5	2 ¹ / ₂	¹ / ₁₆	5 ³ / ₈	1 ¹ / ₁₆	3 ³ / ₄	1 ¹ / ₁₆	1	4	57.4	5.878	G
P44-20M-115	F	44	11.028	10.858	11 ¹ / ₁₆	A-1	8 ¹ / ₁₆	0	5	2 ¹ / ₂	¹ / ₁₆	5 ³ / ₈	1 ¹ / ₁₆	3 ³ / ₄	1 ¹ / ₁₆	1	4	70.8	8.681	G
P48-20M-115	J	48	12.031	11.861	12 ²⁵ / ₃₂	D-1	9 ¹ / ₁₆	0	5	3 ³ / ₁₆	³ / ₈	5 ³ / ₈	1 ¹ / ₁₆	4 ⁵ / ₈	1	1 ¹ / ₂	4 ¹ / ₂	90.9	13.16	G
P52-20M-115	J	52	13.033	12.863	13 ³ / ₄	D-1	10 ³ / ₈	0	5	3 ³ / ₁₆	³ / ₈	5 ³ / ₈	1 ¹ / ₁₆	4 ⁵ / ₈	1	1 ¹ / ₂	4 ¹ / ₂	110.0	18.56	G
P56-20M-115	J	56	14.036	13.856	14 ³ / ₄	D-2	11 ¹ / ₄	9	5	3 ³ / ₁₆	³ / ₈	5 ³ / ₈	1 ¹ / ₁₆	4 ⁵ / ₈	1	1 ¹ / ₂	4 ¹ / ₂	106.0	20.02	G
P60-20M-115	J	60	15.038	14.868	15 ²⁹ / ₃₂	D-2	12 ¹ / ₁₆	9	5	3 ³ / ₁₆	³ / ₈	5 ³ / ₈	1 ¹ / ₁₆	4 ⁵ / ₈	1	1 ¹ / ₂	4 ¹ / ₂	116.0	25.09	G
P64-20M-115	J	64	16.041	15.871	16 ²⁹ / ₃₂	D-2	13 ¹ / ₁₆	9	5	3 ³ / ₁₆	³ / ₈	5 ³ / ₈	1 ¹ / ₁₆	4 ⁵ / ₈	1	1 ¹ / ₂	4 ¹ / ₂	127.0	31.22	G
P68-20M-115	J	68	17.032	16.873	17 ²⁹ / ₃₂	D-2	14 ³ / ₄	9	5	3 ³ / ₁₆	³ / ₈	5 ³ / ₈	1 ¹ / ₁₆	4 ⁵ / ₈	1	1 ¹ / ₂	4 ¹ / ₂	148.0	41.30	G
P72-20M-115	J	72	18.046	17.876	18 ³ / ₄	D-2	15 ¹ / ₁₆	9	5	3 ³ / ₁₆	³ / ₈	5 ³ / ₈	1 ¹ / ₁₆	4 ⁵ / ₈	1	1 ¹ / ₂	4 ¹ / ₂	186.0	52.29	G
P80-20M-115	M	80	20.051	19.881	20 ⁷ / ₈	D-2	17 ¹ / ₄	11 ³ / ₈	5	5 ³ / ₁₆	1 ¹ / ₂	5 ³ / ₈	³ / ₁₆	6 ³ / ₄	0	2	5 ¹ / ₂	237.0	81.91	G
P90-20M-115	M	90	22.557	22.387	23 ¹ / ₃₂	D-2	20 ³ / ₁₆	11 ³ / ₈	5	5 ³ / ₁₆	1 ¹ / ₂	5 ³ / ₈	³ / ₁₆	6 ³ / ₄	0	2	5 ¹ / ₂	275.0	120.1	G
P112-20M-115	M	112	28.071	27.901	—	D-2	26 ³ / ₈	11 ³ / ₈	5	5 ³ / ₁₆	1 ¹ / ₂	5 ³ / ₈	³ / ₁₆	6 ³ / ₄	0	2	5 ¹ / ₂	477.0	273.2	G
P144-20M-115	N	144	36.092	35.922	—	G-3	34 ³ / ₈	12	5	6 ¹ / ₄	2	5 ³ / ₈	0	8 ¹ / ₁₆	⁷ / ₈	2 ¹ / ₁₆	5 ³ / ₈	612.0	408.3	G
P168-20M-115	N	168	42.107	41.937	—	G-3	40 ³ / ₈	12	5	6 ¹ / ₄	2	5 ³ / ₈	0	8 ³ / ₁₆	⁷ / ₈	2 ¹ / ₁₆	5 ³ / ₈	648.0	606.1	G
P192-20M-115	N	192	48.122	47.952	—	G-3	46 ¹ / ₄	12	5	6 ¹ / ₄	2	5 ³ / ₈	0	8 ³ / ₁₆	⁷ / ₈	2 ¹ / ₁₆	5 ³ / ₈	786.0	1068	G
P216-20M-115	N	216	54.136	53.958	—	G-3	52 ¹ / ₄	12	5	6 ¹ / ₄	2	5 ³ / ₈	0	8 ³ / ₁₆	⁷ / ₈	2 ¹ / ₁₆	5 ³ / ₈	907.0	1555	G
230mm (9.06 in) Wide Belts (20M-230)																				
P34-20M-170	MPB	34	8.522	8.352	9 ⁷ / ₁₆	F-1	6 ¹ / ₂	6 ¹ / ₂	7 ⁷ / ₈	—	1 ¹ / ₄	7 ¹ / ₂	—	6 ¹ / ₂	2 ¹ / ₄	2 ¹ / ₈	4 ¹ / ₄	87.2	5.642	G
P36-20M-170	MPB	36	9.023	8.853	9 ⁹ / ₃₂	F-1	7	7	7 ⁷ / ₈	—	1 ¹ / ₄	7 ¹ / ₂	—	6 ¹ / ₂	2 ¹ / ₄	2 ¹ / ₈	4 ¹ / ₂	98.7	7.136	G
P38-20M-170	J	38	9.524	9.354	10 ¹ / ₁₆	A-1	7 ⁷ / ₈	0	7 ⁷ / ₈	3 ³ / ₁₆	⁵ / ₈	7 ¹ / ₂	2 ¹ / ₁₆	4 ⁵ / ₈	2 ¹ / ₈	1 ¹ / ₂	4 ¹ / ₂	64.0	6.369	G
P40-20M-170	J	40	10.026	9.855	10 ³ / ₁₆	A-1	7 ³ / ₄	0	7 ⁷ / ₈	3 ³ / ₁₆	³ / ₄	7 ¹ / ₂	2 ¹ / ₁₆	4 ⁵ / ₈	2 ¹ / ₈	1 ¹ / ₂	4 ¹ / ₂	73.4	8.032	G
P44-20M-170	J	44	11.028	10.858	11 ¹ / ₁₆	A-1	8 ³ / ₈	0	7 ⁷ / ₈	3 ³ / ₁₆	⁵ / ₈	7 ¹ / ₂	2 ¹ / ₁₆	4 ⁵ / ₈	2 ¹ / ₈	1 ¹ / ₂	4 ¹ / ₂	88.1	11.51	G
P48-20M-170	M	48	12.031	11.861	12 ²⁵ / ₃₂	D-1	9 ³ / ₈	0	7 ⁷ / ₈	5 ³ / ₁₆	³ / ₁₆	7 ¹ / ₂	1 ¹ / ₂	6 ³ / ₄	1 ¹ / ₁₆	2	5 ¹ / ₂	120.0	18.50	G
P52-20M-170	M	52	13.033	12.863	13 ³ / ₄	D-1	10 ¹ / ₁₆	0	7 ⁷ / ₈	5 ³ / ₁₆	³ / ₁₆	7 ¹ / ₂	1 ¹ / ₂	6 ³ / ₄	1 ¹ / ₁₆	2	5 ¹ / ₂	149.0	26.45	G
P56-20M-170	M	56	14.036	13.856	14 ³ / ₄	D-1	11 ¹ / ₁₆	0	7 ⁷ / ₈	5 ³ / ₁₆	³ / ₁₆	7 ¹ / ₂	1 ¹ / ₂	6 ³ / ₄	1 ¹ / ₁₆	2	5 ¹ / ₂	177.0	35.64	G
P60-20M-170	M	60	15.038	14.868	15 ²⁹ / ₃₂	D-1	12 ¹ / ₈	0	7 ⁷ / ₈	5 ³ / ₁₆	³ / ₁₆	7 ¹ / ₂	1 ¹ / ₂	6 ³ / ₄	1 ¹ / ₁₆	2	5 ¹ / ₂	209.0	47.39	G
P64-20M-170	M	64	16.041	15.871	16 ²⁹ / ₃₂	D-1	13 ³ / ₈	0	7 ⁷ / ₈	5 ³ / ₁₆	³ / ₁₆	7 ¹ / ₂	1 ¹ / ₂	6 ³ / ₄	1 ¹ / ₁₆	2	5 ¹ / ₂	236.0	61.79	G
P68-20M-170	M	68	17.032	16.873	17 ²⁹ / ₃₂	D-2	14 ¹ / ₁₆	11 ³ / ₈	7 ⁷ / ₈	5 ³ / ₁₆	³ / ₁₆	7 ¹ / ₂	1 ¹ / ₂	6 ³ / ₄	1 ¹ / ₁₆	2	5 ¹ / ₂	214.0	58.93	G
P72-20M-170	M	72	18.046	17.876	18 ³ / ₄	D-2	15 ¹ / ₁₆	11 ³ / ₈	7 ⁷ / ₈	5 ³ / ₁₆	³ / ₁₆	7 ¹ / ₂	1 ¹ / ₂	6 ³ / ₄	1 ¹ / ₁₆	2	5 ¹ / ₂	238.0	73.88	G
P80-20M-170	M	80	20.051	19.881	20 ⁷ / ₈	D-2	17 ¹ / ₁₆	11 ³ / ₈	7 ⁷ / ₈	5 ³ / ₁₆	³ / ₁₆	7 ¹ / ₂	1 ¹ / ₂	6 ³ / ₄	1 ¹ / ₁₆	2	5 ¹ / ₂	262.0	98.45	G
P90-20M-170	M	90	22.557	22.387	23 ¹ / ₃₂	D-2	20 ³ / ₁₆	11 ³ / ₈	7 ⁷ / ₈	5 ³ / ₁₆	³ / ₁₆	7 ¹ / ₂	1 ¹ / ₂	6 ³ / ₄	1 ¹ / ₁₆	2	5 ¹ / ₂	303.0	143.5	G
P112-20M-170	N	112	28.071	27.901	—	D-2	26 ³ / ₄	12	7 ⁷ / ₈	6 ¹ / ₄	³ / ₄	7 ¹ / ₂	1 ¹ / ₄	8 ³ / ₈	0	2 ¹ / ₁₆	5 ³ / ₈	473.0	323.7	G
P144-20M-170	N	144	36.092	35.922	—	D-3	34 ¹ / ₄	12	7 ⁷ / ₈	6 ¹ / ₄	³ / ₄	7 ¹ / ₂	1 ¹ / ₄	8 ³ / ₁₆	0	2 ¹ / ₁₆	5 ³ / ₈	520.0	515.3	G
P168-20M-170	P	168	42.107	41.937	—	G-3	40 ¹ / ₄	14	7 ⁷ / ₈	7 ¹ / ₄	1 ¹ / ₁₆	7 ¹ / ₂	1 ¹ / ₁₆	9 ³ / ₈	1 ¹ / ₁₆	2 ¹ / ₁₆	7	619.0	804.9	G
P192-20M-170	P	192	48.122	47.952	—	G-3	46 ¹ / ₄	14	7 ⁷ / ₈	7 ¹ / ₄	1 ¹ / ₁₆	7 ¹ / ₂	1 ¹ / ₁₆	9 ³ / ₈	1 ¹ / ₁₆	2 ¹ / ₁₆	7	783.0	1315	G
P216-20M-170	P	216	54.136	53.958	—	G-3	52 ¹ / ₄	14	7 ⁷ / ₈	7 ¹ / ₄	1 ¹ / ₁₆	7 ¹ / ₂	1 ¹ / ₁₆	9 ³ / ₈	1 ¹ / ₁₆	2 ¹ / ₁₆	7	902.0	1997	G

†Weight shown is for sprocket without bushing.

G = Gray Iron

Details shown which do not affect drive function may be changed without notification.



Sprocket Specification Tables

20mm Pitch HTD® Stock Sprockets

170mm (6.69 in.) Wide Belts (20M-170)																				
Sprocket Code Symbol	Q.D. Bores	No. of Teeth	Diameters (Inches)			Type	Dimensions (in)								Bore Sizes		Approx. Weight† (lb)	Approx. WR²	Mat'l Spec.	
			Pitch	O.D.	Flange		A	B	C	D	E	F	K	L	M	Min.				Max.
P38-20M-230	MPB	38	9.524	9.354	10 ¹ / ₁₆	F-1	7 ⁷ / ₁₆	7 ¹ / ₂	9 ¹ / ₂	—	1 ¹ / ₄	9 ⁷ / ₈	—	7 ¹ / ₂	3 ³ / ₈	2 ⁷ / ₈	4 ³ / ₄	128.0	11.06	G
P40-20M-230	MPB	40	10.026	9.855	10 ¹ / ₁₆	F-1	8	8	9 ¹ / ₂	—	1 ¹ / ₄	9 ⁷ / ₈	—	8 ¹ / ₂	2 ⁵ / ₈	2 ⁷ / ₈	5 ¹ / ₄	156.0	14.35	G
P44-20M-230	MPB	44	11.028	10.858	11 ¹ / ₁₆	F-1	8 ¹⁵ / ₁₆	8 ³ / ₄	9 ¹ / ₂	—	1 ¹ / ₄	9 ⁷ / ₈	—	8 ¹ / ₂	2 ⁵ / ₈	2 ⁷ / ₈	6	189.0	21.65	G
P48-20M-230	M	48	12.031	11.861	12 ² / ₃₂	A-1	9 ¹⁵ / ₁₆	0	9 ¹ / ₂	5 ⁵ / ₁₆	³ / ₁₆	9 ⁷ / ₈	2	6 ³ / ₄	2 ¹ / ₁₆	2	5 ¹ / ₂	140.0	21.86	G
P52-20M-230	M	52	13.033	12.863	13 ³ / ₄	A-1	10 ⁵ / ₃₂	0	9 ¹ / ₂	5 ⁵ / ₁₆	³ / ₁₆	9 ⁷ / ₈	2	6 ³ / ₄	2 ¹ / ₁₆	2	5 ¹ / ₂	175.0	31.64	G
P56-20M-230	M	56	14.036	13.856	14 ³ / ₄	A-1	11 ⁵ / ₁₆	0	9 ¹ / ₂	5 ⁵ / ₁₆	³ / ₁₆	9 ⁷ / ₈	2	6 ³ / ₄	2 ¹ / ₁₆	2	5 ¹ / ₂	204.0	42.74	G
P60-20M-230	M	60	15.038	14.868	15 ² / ₃₂	A-1	12 ¹ / ₁₆	0	9 ¹ / ₂	5 ⁵ / ₁₆	³ / ₁₆	9 ⁷ / ₈	2	6 ³ / ₄	2 ¹ / ₁₆	2	5 ¹ / ₂	234.0	54.44	G
P64-20M-230	M	64	16.041	15.871	16 ² / ₃₂	A-1	13 ¹⁵ / ₁₆	0	9 ¹ / ₂	5 ⁵ / ₁₆	³ / ₁₆	9 ⁷ / ₈	2	6 ³ / ₄	2 ¹ / ₁₆	2	5 ¹ / ₂	270.0	70.49	G
P68-20M-230	N	68	17.032	16.873	17 ² / ₃₂	D-1	14 ⁵ / ₈	0	9 ¹ / ₂	6 ¹ / ₄	³ / ₁₆	9 ⁷ / ₈	1 ¹ / ₁₆	8 ³ / ₈	1 ¹ / ₁₆	2 ¹ / ₁₆	5 ⁷ / ₈	341.0	98.76	G
P72-20M-230	N	72	18.046	17.876	18 ⁷ / ₈	D-1	15 ¹ / ₃₂	0	9 ¹ / ₂	6 ¹ / ₄	³ / ₁₆	9 ⁷ / ₈	1 ¹ / ₁₆	8 ³ / ₈	1 ¹ / ₁₆	2 ¹ / ₁₆	5 ⁷ / ₈	410.0	127.3	G
P80-20M-230	N	80	20.051	19.881	20 ⁵ / ₈	D-2	17 ¹ / ₂	12	9 ¹ / ₂	6 ¹ / ₄	³ / ₁₆	9 ⁷ / ₈	1 ¹ / ₁₆	8 ³ / ₈	1 ¹ / ₁₆	2 ¹ / ₁₆	5 ⁷ / ₈	343.0	128.9	G
P90-20M-230	N	90	22.557	22.387	23 ¹ / ₃₂	D-2	20 ¹ / ₁₆	12	9 ¹ / ₂	6 ¹ / ₄	³ / ₁₆	9 ⁷ / ₈	1 ¹ / ₁₆	8 ³ / ₈	1 ¹ / ₁₆	2 ¹ / ₁₆	5 ⁷ / ₈	398.0	187.5	G
P112-20M-230	N	112	28.071	27.901	—	D-2	26 ¹ / ₄	12	9 ¹ / ₂	6 ¹ / ₄	³ / ₁₆	9 ⁷ / ₈	1 ¹ / ₁₆	8 ³ / ₈	1 ¹ / ₁₆	2 ¹ / ₁₆	5 ⁷ / ₈	664.0	368.8	G
P144-20M-230	P	144	36.092	35.922	—	D-3	34 ³ / ₄	14	9 ¹ / ₂	7 ¹ / ₄	¹ / ₄	9 ⁷ / ₈	1 ¹ / ₁₆	9 ⁷ / ₈	1 ⁵ / ₁₆	2 ¹ / ₁₆	7	886.0	637.1	G
P168-20M-230	P	168	42.107	41.937	—	D-3	40 ³ / ₄	14	9 ¹ / ₂	7 ¹ / ₄	¹ / ₄	9 ⁷ / ₈	1 ¹ / ₁₆	9 ⁷ / ₈	1 ⁵ / ₁₆	2 ¹ / ₁₆	7	934.0	967.5	G
P192-20M-230	W	192	48.122	47.952	—	G-3	46	17	9 ¹ / ₂	9	1	9 ⁷ / ₈	1 ¹ / ₂	11 ³ / ₈	⁵ / ₈	4	8 ¹ / ₂	1429.0	2203	G
P216-20M-230	W	216	54.136	53.958	—	G-3	52	17	9 ¹ / ₂	9	1	9 ⁷ / ₈	1 ¹ / ₂	11 ³ / ₈	⁵ / ₈	4	8 ¹ / ₂	1317.0	2576	G
290mm (11.42 in) Wide Belts (20M-290)																				
P52-20M-290	N	52	13.033	12.863	13 ³ / ₄	A-1	10 ¹ / ₁₆	0	11 ¹ / ₈	6 ¹ / ₄	¹ / ₂	12 ¹ / ₄	2 ¹ / ₂	8 ³ / ₈	3 ¹ / ₂	2 ¹ / ₁₆	5 ⁷ / ₈	202.0	37.46	G
P56-20M-290	N	56	14.036	13.856	14 ³ / ₄	A-1	11 ¹ / ₈	0	11 ¹ / ₈	6 ¹ / ₄	¹ / ₂	12 ¹ / ₄	2 ¹ / ₂	8 ³ / ₈	3 ¹ / ₂	2 ¹ / ₁₆	5 ⁷ / ₈	237.0	50.16	G
P60-20M-290	N	60	15.038	14.868	15 ² / ₃₂	A-1	13	0	11 ¹ / ₈	6 ¹ / ₄	¹ / ₂	12 ¹ / ₄	2 ¹ / ₂	8 ³ / ₈	3 ¹ / ₂	2 ¹ / ₁₆	5 ⁷ / ₈	276.0	65.49	G
P64-20M-290	N	64	16.041	15.871	16 ² / ₃₂	A-1	14	0	11 ¹ / ₈	6 ¹ / ₄	¹ / ₂	12 ¹ / ₄	2 ¹ / ₂	8 ³ / ₈	3 ¹ / ₂	2 ¹ / ₁₆	5 ⁷ / ₈	320.0	84.94	G
P68-20M-290	N	68	17.032	16.873	17 ² / ₃₂	A-1	14 ¹ / ₁₆	0	11 ¹ / ₈	6 ¹ / ₄	¹ / ₂	12 ¹ / ₄	2 ¹ / ₂	8 ³ / ₈	3 ¹ / ₂	2 ¹ / ₁₆	5 ⁷ / ₈	368.0	109.1	G
P72-20M-290	N	72	18.046	17.876	18 ⁷ / ₈	A-2	15 ¹ / ₃₂	12	11 ¹ / ₈	6 ¹ / ₄	¹ / ₂	12 ¹ / ₄	2 ¹ / ₂	8 ³ / ₈	3 ¹ / ₂	2 ¹ / ₁₆	5 ⁷ / ₈	404.0	120.6	G
P80-20M-290	N	80	20.051	19.881	20 ⁵ / ₈	A-2	17 ¹ / ₃₂	12	11 ¹ / ₈	6 ¹ / ₄	¹ / ₂	12 ¹ / ₄	2 ¹ / ₂	8 ³ / ₈	3 ¹ / ₂	2 ¹ / ₁₆	5 ⁷ / ₈	376.0	146.7	G
P90-20M-290	N	90	22.557	22.387	23 ¹ / ₃₂	A-2	20 ¹ / ₁₆	12	11 ¹ / ₈	6 ¹ / ₄	¹ / ₂	12 ¹ / ₄	2 ¹ / ₂	8 ³ / ₈	3 ¹ / ₂	2 ¹ / ₁₆	5 ⁷ / ₈	431.0	210.6	G
P112-20M-290	P	112	28.071	27.901	—	A-2	26 ¹ / ₈	14	11 ¹ / ₈	7 ¹ / ₄	¹ / ₄	12 ¹ / ₄	2 ¹ / ₂	9 ⁷ / ₈	2 ¹ / ₂	2 ¹ / ₁₆	7	799.0	447.8	G
P144-20M-290	P	144	36.092	35.922	—	A-3	34	14	11 ¹ / ₈	7 ¹ / ₄	¹ / ₄	12 ¹ / ₄	2 ¹ / ₂	9 ⁷ / ₈	2 ¹ / ₂	2 ¹ / ₁₆	7	1004.00	818.9	G
P168-20M-290	W	168	42.107	41.937	—	A-3	40	17	11 ¹ / ₈	9	³ / ₁₆	12 ¹ / ₄	2 ¹ / ₁₆	11 ³ / ₈	⁷ / ₁₆	4	8 ¹ / ₂	1410.0	1669	G
P192-20M-290	W	192	48.122	47.952	—	A-3	46	17	11 ¹ / ₈	9	³ / ₁₆	12 ¹ / ₄	2 ¹ / ₁₆	11 ³ / ₈	⁷ / ₁₆	4	8 ¹ / ₂	1552.0	2491	G
P216-20M-290	W	216	54.136	53.958	—	A-3	52	17	11 ¹ / ₈	9	³ / ₁₆	12 ¹ / ₄	2 ¹ / ₁₆	11 ³ / ₈	⁷ / ₁₆	4	8 ¹ / ₂	1441.0	2991	G
340mm (13.39 in) Wide Belts (20M-340)																				
P52-20M-340	N	52	13.033	12.863	13 ³ / ₄	A-1	10 ¹ / ₁₆	0	13 ³ / ₈	6 ¹ / ₄	¹ / ₂	14 ¹ / ₄	2 ¹ / ₂	8 ³ / ₈	5 ¹ / ₂	2 ¹ / ₁₆	5 ⁷ / ₈	219.0	41.49	G
P56-20M-340	N	56	14.036	13.856	14 ³ / ₄	A-1	11 ¹ / ₈	0	13 ³ / ₈	6 ¹ / ₄	¹ / ₂	14 ¹ / ₄	2 ¹ / ₂	8 ³ / ₈	5 ¹ / ₂	2 ¹ / ₁₆	5 ⁷ / ₈	258.0	55.14	G
P60-20M-340	N	60	15.038	14.868	15 ² / ₃₂	A-1	13 ¹ / ₁₆	0	13 ³ / ₈	6 ¹ / ₄	¹ / ₂	14 ¹ / ₄	2 ¹ / ₂	8 ³ / ₈	5 ¹ / ₂	2 ¹ / ₁₆	5 ⁷ / ₈	294.0	70.61	G
P64-20M-340	N	64	16.041	15.871	16 ² / ₃₂	A-1	14 ¹ / ₁₆	0	13 ³ / ₈	6 ¹ / ₄	¹ / ₂	14 ¹ / ₄	2 ¹ / ₂	8 ³ / ₈	5 ¹ / ₂	2 ¹ / ₁₆	5 ⁷ / ₈	339.0	91.26	G
P68-20M-340	N	68	17.032	16.873	17 ² / ₃₂	A-1	15	0	13 ³ / ₈	6 ¹ / ₄	¹ / ₂	14 ¹ / ₄	2 ¹ / ₂	8 ³ / ₈	5 ¹ / ₂	2 ¹ / ₁₆	5 ⁷ / ₈	389.0	117.1	G
P72-20M-340	N	72	18.046	17.876	18 ⁷ / ₈	A-2	15 ¹ / ₃₂	12	13 ³ / ₈	6 ¹ / ₄	¹ / ₂	14 ¹ / ₄	2 ¹ / ₂	8 ³ / ₈	5 ¹ / ₂	2 ¹ / ₁₆	5 ⁷ / ₈	438.0	133.5	G
P80-20M-340	P	80	20.051	19.881	20 ⁵ / ₈	A-2	18	14	13 ³ / ₈	7 ¹ / ₄	¹ / ₄	14 ¹ / ₄	3 ¹ / ₂	9 ⁷ / ₈	3 ¹ / ₂	2 ¹ / ₁₆	7	462.0	183.9	G
P90-20M-340	P	90	22.557	22.387	23 ¹ / ₃₂	A-2	20 ¹ / ₁₆	14	13 ³ / ₈	7 ¹ / ₄	¹ / ₄	14 ¹ / ₄	3 ¹ / ₂	9 ⁷ / ₈	3 ¹ / ₂	2 ¹ / ₁₆	7	507.0	245.1	G
P112-20M-340	P	112	28.071	27.901	—	A-2	26 ¹ / ₃₂	14	13 ³ / ₈	7 ¹ / ₄	¹ / ₄	14 ¹ / ₄	3 ¹ / ₂	9 ⁷ / ₈	3 ¹ / ₂	2 ¹ / ₁₆	7	870.0	492.1	G
P144-20M-340	W	144	36.092	35.922	—	A-3	34	17	13 ³ / ₈	9	⁷ / ₈	14 ¹ / ₄	2 ⁵ / ₈	11 ³ / ₈	2 ⁵ / ₈	4	8 ¹ / ₂	1215.0	982.1	G
P168-20M-340	W	168	42.107	41.937	—	A-3	40	17	13 ³ / ₈	9	⁷ / ₈	14 ¹ / ₄	2 ⁵ / ₈	11 ³ / ₈	2 ⁵ / ₈	4	8 ¹ / ₂	1514.0	1829	G
P192-20M-340	S	192	48.122	47.952	—	D-3	46	19	13 ³ / ₈	12	2 ³ / ₈	14 ¹ / ₄	1 ⁷ / ₈	15 ¹ / ₄	1 ⁷ / ₈	5 ¹ / ₂	10	1817.0	2847	G
P216-20M-340	S	216	54.136	53.958	—	D-3	51 ¹ / ₈	19	13 ³ / ₈	12	2 ³ / ₈	14 ¹ / ₄	1 ⁷ / ₈	15 ¹ / ₄	1 ⁷ / ₈	5 ¹ /				

Gates PowerGrip® Timing Belt Pulleys

0.200" Pitch, XL For ¼" and ⅜" Wide Belts

Pulley Designation	Number of Grooves	Pitch Diameter (in)	Outside Diameter (in)
10XL037	10	.637	.617
11XL037	11	.700	.680
12XL037	12	.764	.744
14XL037	14	.891	.871
15XL037	15	.955	.935
16XL037	16	1.019	.999
18XL037	18	1.146	1.126
20XL037	20	1.273	1.253
21XL037	21	1.337	1.317
22XL037	22	1.401	1.381
24XL037	24	1.528	1.508
28XL037	28	1.783	1.763
30XL037	30	1.910	1.890
32XL037	32	2.037	2.017
36XL037	36	2.292	2.272
40XL037	40	2.546	2.526
42XL037	42	2.674	2.654
44XL037	44	2.801	2.781
48XL037	48	3.056	3.036
60XL037	60	3.820	3.800
72XL037	72	4.584	4.564

0.375" Pitch, L For ½" Wide Belts

Pulley Designation	Number of Grooves	Pitch Diameter (in)	Outside Diameter (in)
10L050	10	1.194	1.164
12L050	12	1.432	1.402
14L050	14	1.671	1.641
16L050	16	1.910	1.880
17L050	17	2.029	1.999
18L050	18	2.149	2.119
19L050	19	2.268	2.238
20L050	20	2.387	2.357
21L050	21	2.507	2.477
22L050	22	2.626	2.596
24L050	24	2.865	2.835
26L050	26	3.104	3.074
28L050	28	3.342	3.312
30L050	30	3.581	3.551
32L050	32	3.820	3.790
40L050	40	4.775	4.745
48L050	48	5.730	5.700
60L050	60	7.162	7.132
72L050	72	8.594	8.564
84L050	84	10.027	9.997

0.375" Pitch, L For ¾" Wide Belts

Pulley Designation	Number of Grooves	Pitch Diameter (in)	Outside Diameter (in)
12L075	12	1.432	1.402
14L075	14	1.671	1.641
16L075	16	1.910	1.880
17L075	17	2.029	1.999
18L075	18	2.149	2.119
19L075	19	2.268	2.238
20L075	20	2.387	2.357
21L075	21	2.507	2.477
22L075	22	2.626	2.596
24L075	24	2.865	2.835
26L075	26	3.104	3.074
28L075	28	3.342	3.312
30L075	30	3.581	3.551
32L075	32	3.820	3.790
40L075	40	4.775	4.745
48L075	48	5.730	5.700
60L075	60	7.162	7.132
72L075	72	8.594	8.564
84L075	84	10.027	9.997

0.375" Pitch, L For 1" Wide Belts

Pulley Designation	Number of Grooves	Pitch Diameter (in)	Outside Diameter (in)
14L100	14	1.671	1.641
16L100	16	1.910	1.880
17L100	17	2.029	1.999
18L100	18	2.149	2.119
19L100	19	2.268	2.238
20L100	20	2.387	2.357
21L100	21	2.507	2.477
22L100	22	2.626	2.596
24L100	24	2.865	2.835
26L100	26	3.104	3.074
28L100	28	3.342	3.312
30L100	30	3.581	3.551
32L100	32	3.820	3.790
40L100	40	4.775	4.745
48L100	48	5.730	5.700
60L100	60	7.162	7.132
72L100	72	8.594	8.564
84L100	84	10.027	9.997

0.500" Pitch, H For ¾" and 1" Wide Belts

Pulley Designation	Number of Grooves	Pitch Diameter (in)	Outside Diameter (in)
14H100	14	2.228	2.174
16H100	16	2.546	2.492
18H100	18	2.865	2.811
20H100	20	3.183	3.129
22H100	22	3.501	3.447
24H100	24	3.820	3.766
26H100	26	4.138	4.084
28H100	28	4.456	4.402
30H100	30	4.775	4.721
32H100	32	5.093	5.039
40H100	40	6.366	6.312
48H100	48	7.639	7.585
60H100	60	9.549	9.495
72H100	72	11.459	11.405
84H100	84	13.369	13.315
96H100	96	15.279	15.225
120H100	120	19.099	19.045

0.500" Pitch, H For 1½" Wide Belts

Pulley Designation	Number of Grooves	Pitch Diameter (in)	Outside Diameter (in)
14H150	14	2.228	2.174
16H150	16	2.546	2.492
18H150	18	2.865	2.811
20H150	20	3.183	3.129
22H150	22	3.501	3.447
24H150	24	3.820	3.766
26H150	26	4.138	4.084
28H150	28	4.456	4.402
30H150	30	4.775	4.721
32H150	32	5.093	5.039
40H150	40	6.366	6.312
48H150	48	7.639	7.585
60H150	60	9.549	9.495
72H150	72	11.459	11.405
84H150	84	13.369	13.315
96H150	96	15.279	15.225
120H150	120	19.099	19.045

0.500" Pitch, H For 2" Wide Belts

Pulley Designation	Number of Grooves	Pitch Diameter (in)	Outside Diameter (in)
16H200	16	2.546	2.492
18H200	18	2.865	2.811
20H200	20	3.183	3.129
22H200	22	3.501	3.447
24H200	24	3.820	3.766
26H200	26	4.138	4.084
28H200	28	4.456	4.402
30H200	30	4.775	4.721
32H200	32	5.093	5.039
40H200	40	6.366	6.312
48H200	48	7.639	7.585
60H200	60	9.549	9.495
72H200	72	11.459	11.405
84H200	84	13.369	13.315
96H200	96	15.279	15.225
120H200	120	19.099	19.045

0.500" Pitch, H For 3" Wide Belts

Pulley Designation	Number of Grooves	Pitch Diameter (in)	Outside Diameter (in)
16H300	16	2.546	2.492
18H300	18	2.865	2.811
20H300	20	3.183	3.129
22H300	22	3.501	3.447
24H300	24	3.820	3.766
26H300	26	4.138	4.084
28H300	28	4.456	4.402
30H300	30	4.775	4.721
32H300	32	5.093	5.039
40H300	40	6.366	6.312
48H300	48	7.639	7.585
60H300	60	9.549	9.495
72H300	72	11.459	11.405
84H300	84	13.369	13.315
96H300	96	15.279	15.225
120H300	120	19.099	19.045



Sprocket Specifications

Sprocket Tolerance Specifications

PowerGrip® GT®2 sprockets are made to close tolerances. Modifications such as reboring may result in unsatisfactory drive performance. Strict adherence to the standard tolerances (as shown in table below) is highly recommended.

Sprocket Outside Diameter and Pitch

Outside Diameter Range (in)	Outside Diameter Tolerance (in)	Pitch To Pitch Tolerance (in)	
		Adjacent Grooves	Accumulative Over 90 Degrees
Over 2.000 to and including 4.000	+ 0.004 - 0.000	± 0.001	± 0.0045
Over 4.000 to and including 7.000	+ 0.005 - 0.000	± 0.001	± 0.005
Over 7.000 to and including 12.000	+ 0.006 - 0.000	± 0.001	± 0.006
Over 12.000 to and including 20.000	+ 0.007 - 0.000	± 0.001	± 0.0065
Over 20.000	+ 0.008 - 0.000	± 0.001	± 0.0075

Sprocket Runout

Radial Runout*

Outside Diameter		Total Eccentricity Total Indicator Reading	
(in)	(mm)	(in)	(mm)
Up to 2	50	0.0025	0.06
Over 2 to 4	50 100	0.003	0.08
Over 4 to 8	100 200	0.004	0.10
Over 8	200	.0005 per inch O.D. over 8"	.013 per mm O.D. over 200mm
(may not exceed face diameter tolerance)			

* Total Indicator Reading

Axial Runout*

For outside diameters 1.0 inches and under. . . 0.001 inches

For each additional inch of outside diameter up through 10.0 inches, add 0.001 inches

For each additional inch of outside diameter over 10.0 inches, add 0.0005 inches

* Total Indicator Reading

Sprocket and Bushing Keyseat

Shaft Diameter (in)	Width w_k † (in)	Depth, h_k (in) + 0.015 0.000
Up through $\frac{3}{16}$ (0.44)	$\frac{3}{32}$ (0.0938)	$\frac{3}{64}$ (0.047)
Over $\frac{3}{16}$ (0.44) to and incl. $\frac{9}{16}$ (0.56)	$\frac{1}{8}$ (0.125)	$\frac{1}{16}$ (0.062)
Over $\frac{9}{16}$ (0.56) to and incl. $\frac{3}{4}$ (0.88)	$\frac{3}{16}$ (0.1875)	$\frac{3}{32}$ (0.094)
Over $\frac{3}{4}$ (0.88) to and incl. $1\frac{1}{4}$ (1.25)	$\frac{1}{4}$ (0.250)	$\frac{1}{8}$ (0.125)
Over $1\frac{1}{4}$ (1.25) to and incl. $1\frac{3}{8}$ (1.38)	$\frac{5}{16}$ (0.3125)	$\frac{5}{32}$ (0.156)
Over $1\frac{3}{8}$ (1.38) to and incl. $1\frac{1}{2}$ (1.75)	$\frac{3}{8}$ (0.375)	$\frac{3}{16}$ (0.188)
Over $1\frac{1}{2}$ (1.75) to and incl. $2\frac{1}{4}$ (2.25)	$\frac{1}{2}$ (0.500)	$\frac{1}{4}$ (0.250)
Over $2\frac{1}{4}$ (2.25) to and incl. $2\frac{3}{4}$ (2.75)	$\frac{5}{8}$ (0.625)	$\frac{5}{16}$ (0.312)
Over $2\frac{3}{4}$ (2.75) to and incl. $3\frac{1}{2}$ (3.25)	$\frac{3}{4}$ (0.750)	$\frac{3}{8}$ (0.375)
Over $3\frac{1}{4}$ (3.25) to and incl. $3\frac{3}{4}$ (3.75)	$\frac{7}{8}$ (0.875)	$\frac{7}{16}$ (0.438)
Over $3\frac{3}{4}$ (3.75) to and incl. $4\frac{1}{2}$ (4.50)	1 (1.000)	$\frac{1}{2}$ (0.500)
Over $4\frac{1}{2}$ (4.50) to and incl. $5\frac{1}{2}$ (5.50)	$1\frac{1}{4}$ (1.250)	$\frac{3}{8}$ (0.625)

†Tolerance on width, W_k
 For width up through 1/2 (0.500) + 0.002, 0.000 inches
 For width over 1/2 (0.500) up through 1 (1.000) . . . + 0.003, 0.000 inches
 For width over 1 (1.000) + 0.004, 0.000 inches

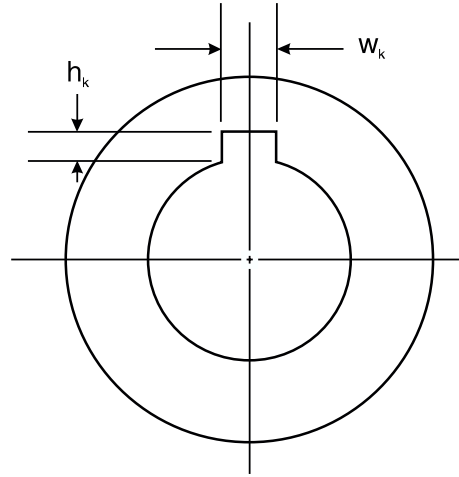

Balancing

Stock Sprockets are statically balanced per MPTA (Mechanical Power Transmission Association) Standard Practice for Pulley Balancing SPB-86 using the weight based on the following two criteria:

1. Balance limit (ounces) = Sprocket Weight (lb) x 0.016; or
2. 0.176 ounce (5 grams), whichever is greater.

Caution: Stock sprockets should not be used on drives where rim surface speeds exceed 6,500 fpm. Sprocket construction and materials will determine the dynamic balancing requirements of the sprocket(s) where rim surface speeds exceed 6,500 fpm.

Sprocket Tooth Profile and Surface Quality

The PowerGrip GT2 sprocket tooth profile was designed and developed exclusively by The Gates Rubber Company to operate with the Gates PowerGrip GT2 Belt. See Engineering Section II-3, Tooth Profile, on page 137 for a complete discussion of the performance characteristics of this new tooth profile. The tooth surface should be free of any surface defects and should be 80 microinches finish or better.

Sprocket Blanks

Sprocket blanks can be grooved by Gates for specially designed, made-to-order sprockets. If those sprockets are supplied in blank form, Gates can perform the "grooving" operation. The blank diameter must be 0.050" larger than the finished sprocket O.D. Contact your local Gates Representative for additional details.

For Minimum Plain Bore (MPB) Sprockets

When using MPB PowerGrip® GT®2 sprockets in power transmission systems, important guidelines should be followed for proper product finishing and application. Due to the high load carrying capacity and high operating tensions often found in PowerGrip GT2 belt drive systems, it is imperative to use and adhere to industry standard practices.

When finishing MPB sprockets for high performance belt drive systems, care should be taken to ensure proper functionality and performance. General re-bore instructions and specifications are as follows:

1. Materials used in PowerGrip GT2 sprockets are steel, gray iron, and ductile iron. The materials used may vary with the size of the sprocket. See the Sprocket Specification Tables, pages 101 thru 111 for specific materials.
2. The maximum bore diameter specified by the manufacturer for each sprocket size should NOT be exceeded, or a keyway used which reduces the hub thickness to less than its minimum allowable value. See the Sprocket Specification Tables for a listing of recommended bore ranges by sprocket size. Bores exceeding the maximum recommended value for a particular sprocket size can adversely affect the structural integrity, thereby reducing their load-carrying capability.

The minimum metal thickness between the keyway and hub O.D. should be no less than the set screw diameter specified for the corresponding sprocket size. See Figure 1. A listing of minimum set screw diameters is included below.

- P18-5MGT - 8-32
- P19-5MGT thru P22-5MGT -10-32
- P23-5MGT thru P32-5MGT -1/4"
- P34-5MGT thru P38-5MGT -5/16"
- P40-5MGT thru P50-5MGT -3/8"
- P28-14MGT thru P29-14MGT -7/16"
- P36-14MGT thru P38-14MGT -5/8"

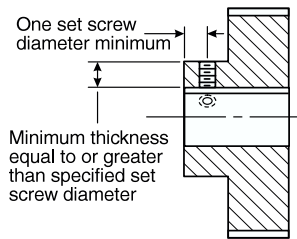

Figure 1 — Minimum Hub Thickness And Set Screw Placement Guidelines

3. The fit between a finished sprocket bore and its mating shaft in a power transmission system must not allow relative movement between the bore and the shaft when the drive is subjected to belt tension and torque loads. This is accomplished, in the case of plain bore sprockets, with the use of set screws and keys and by controlling the fit or clearance between the sprocket bore and its mating shaft. Cyclical, pulsating, or reversing loads may wear the sprocket bore and/or keyway due to the relative movement between the contacting surfaces of the shaft and the bore. The resulting wear may increase the clearance further, if an interference fit is not used.

In order to maximize the performance of high capacity belt drives using plain bore style sprockets, the following for recommendations presented in Table 1 should be followed:

Class 1 Clearance Fits should be used when the transmitted load is smooth in nature.

Interference Fits should be used for PowerGrip GT2 curvilinear drives *transmitting cyclical, pulsating, or reversing loads*.

Table 1 - Recommended Shaft / Bore Fits (Inches)

Nominal Bore Range Over - To (Incl.)	Shaft Tol. (minus)	Clearance Fits		Interference Fits			
		Bore Tol. (Plus)	Fit Tol. (Plus)	Cyclical, Pulsating, Reversing Load			
				Class 1- Smooth Load		Bore Tolerance Range (Minus)	
0.4375 - 0.5626	0.0005	0.0010	0.0015	0.0005	0.0010	0.0000	0.0010
0.5625 - 0.8750	0.0005	0.0010	0.0015	0.0005	0.0010	0.0000	0.0010
0.8750 - 1.2500	0.0005	0.0010	0.0015	0.0005	0.0010	0.0000	0.0010
1.2500 - 1.3750	0.0005	0.0010	0.0015	0.0005	0.0010	0.0000	0.0010
1.3750 - 1.5000	0.0005	0.0010	0.0015	0.0005	0.0010	0.0000	0.0010
1.5000 - 1.7500	0.0010	0.0010	0.0020	0.0010	0.0020	0.0000	0.0020
1.7500 - 2.0000	0.0010	0.0010	0.0020	0.0010	0.0020	0.0000	0.0020
2.0000 - 2.2500	0.0010	0.0015	0.0025	0.0010	0.0020	0.0000	0.0020
2.2500 - 2.7500	0.0010	0.0015	0.0025	0.0010	0.0020	0.0000	0.0020
2.7500 - 3.0000	0.0010	0.0015	0.0025	0.0010	0.0020	0.0000	0.0020
3.0000 - 3.2500	0.0010	0.0015	0.0025	0.0015	0.0030	0.0005	0.0030
3.2500 - 3.7500	0.0010	0.0015	0.0025	0.0015	0.0030	0.0005	0.0030
3.7500 - 4.0000	0.0010	0.0015	0.0025	0.0015	0.0030	0.0005	0.0030
4.0000 - 4.5000	0.0010	0.0015	0.0025	0.0020	0.0035	0.0010	0.0035
4.5000 - 5.0000	0.0010	0.0015	0.0025	0.0020	0.0035	0.0010	0.0035
5.0000 - 5.5000	0.0010	0.0015	0.0025	0.0025	0.0040	0.0015	0.0040
5.5000 - 6.5000	0.0010	0.0015	0.0025	0.0025	0.0040	0.0015	0.0040

Table 1 was extracted in part from AGMA Standard for Bores and Keyways for Flexible Couplings (Inch Series) AGMA 9002-A86 Table.

4. **DO NOT** chuck or center the sprocket on guide flanges. Soft jaws should be used when chucking on the sprocket teeth. Center (indicate) the sprocket using the sprocket tooth O.D.

If chucked on the Rim I.D. or Hub O.D., the sprocket should be centered with respect to the sprocket tooth O.D. Guide flanges are permanently mounted and should not be removed. If original flanges must be removed, they should be replaced with NEW flanges. New guide flanges should be attached securely with care using mechanical fasteners such as screws. **Note: Improper guide flange reassembly may cause serious personal injury and/or mechanical damage.**

5. Set screw holes in the sprocket hub must be placed properly for maximum holding strength. For both standard and shallow keyseats, two (2) set screws should be used as illustrated in Figure 2. The total holding strength of the set screws is dependent upon their placement and design. Generally, one screw should be placed directly over the keyway, and the other screw at ninety degrees (90°) from the keyway, or at sixty-five degrees (65°) from the keyway—a more recent practice that improves holding power. Sometimes four set screws (or two pair) are used for increased holding strength.

For Minimum Plain Bore (MPB) Sprockets

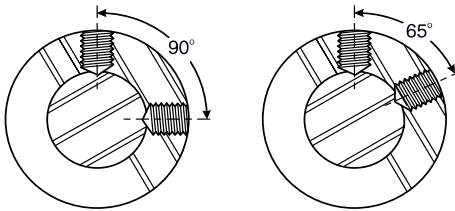

Figure 2 — Set Screw Angles

Each set screw should be placed axially—a minimum of one set screw diameter from the end of the sprocket hub extension. See Figure 1. For recommended set screw

Table 2 — Recommended Tightening Torque Values For Set Screws

Set Screw Size	Hex Key Size (in)	Approximate Installation Torque Values (lb-in)
8-32	$\frac{5}{64}$	20
10-32	$\frac{3}{32}$	35
$\frac{1}{4}$	$\frac{1}{8}$	80
$\frac{5}{16}$	$\frac{5}{32}$	160
$\frac{3}{8}$	$\frac{3}{16}$	275
$\frac{7}{16}$	$\frac{7}{32}$	430
$\frac{1}{2}$	$\frac{1}{4}$	615
$\frac{5}{8}$	$\frac{5}{16}$	1315

tightening torque values see Table 2 below.

- After re-boring, the sprocket may require rebalancing. Vibration, noise, reduced bearing life, and undue stresses on the mechanical components in the system could result if improper rebalancing practices are used. See Sprocket Specifications, page 116, for recommended sprocket balancing specifications.
- Standard square or rectangular keys should be used. See page 121 for standard key dimensions.

Refer to Sprocket Specifications, page 116, for specifications and tolerances for sprocket eccentricity, parallelism, and balancing.

Stock Bushings for Sprockets

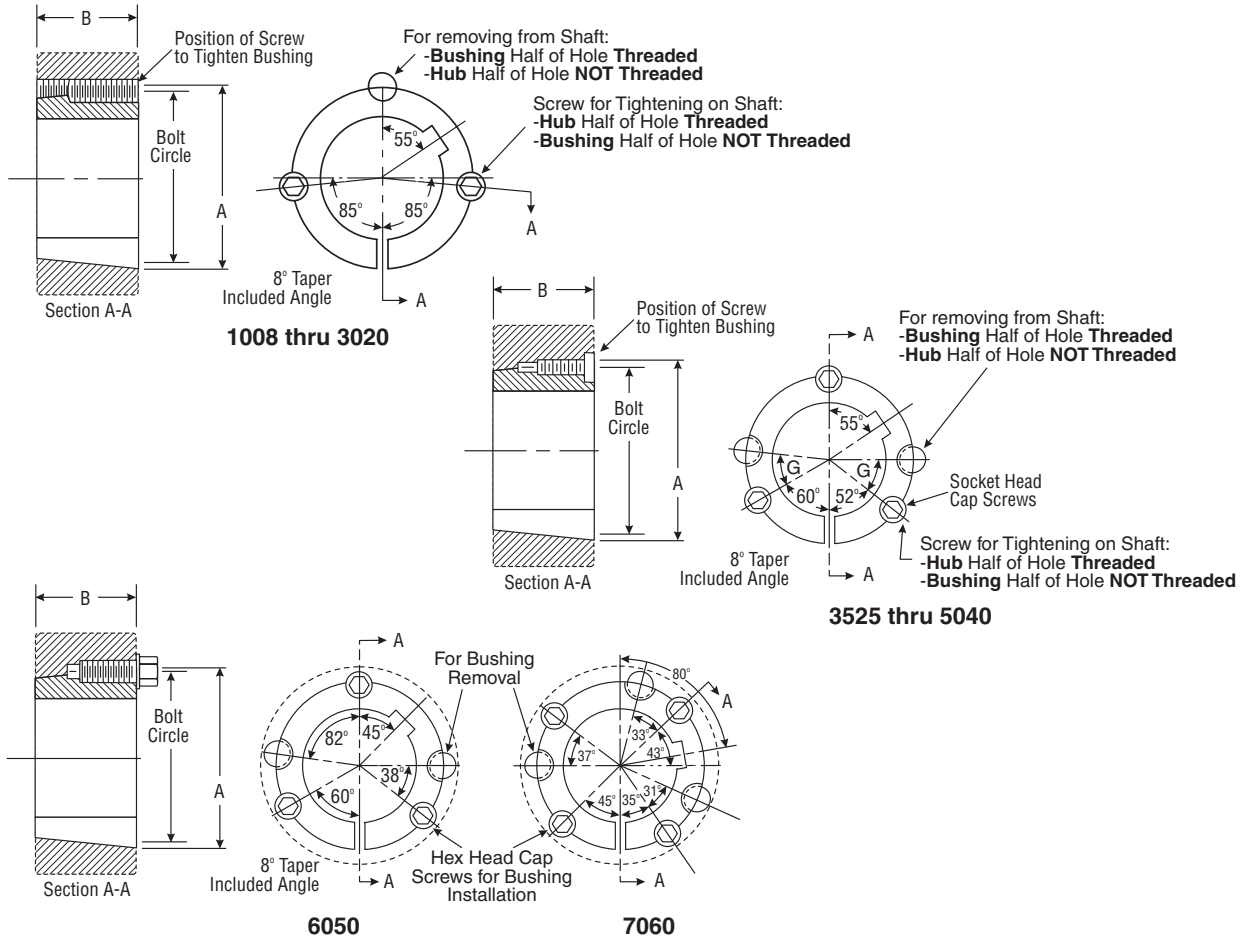

TAPER-LOCK* BUSHINGS

Bushing Size	Torque Capacity (lb-in)	Dimensions (in)		Bolt Circle (in)	Mounting Screws			Bore Range (in)			Weight Range (lb)	
								Min. Bore	Max Bore			
		A	B		Qty.	Size	G (deg)		Standard Keyseat***	Shallow Keyseat**	Max. Bore	Min. Bore
1008	1,200	1.386	0.875	1.328	2	1/4 x 1/2	—	0.500	0.875	1.000	0.2	0.3
1108	1,300	1.511	0.875	1.328	2	1/4 x 1/2	—	0.500	1.000	1.125	0.1	0.3
1210	3,600	1.875	1.000	1.750	2	3/8 x 5/8	—	0.500	1.250	—	0.4	0.6
1610	4,300	2.250	1.000	2.125	2	3/8 x 5/8	—	0.500	1.500	1.688	0.5	0.9
1615	4,300	2.25	1.500	2.125	2	3/8 x 5/8	—	0.500	1.500	1.688	0.6	1.3
2012	7,150	2.750	1.250	2.625	2	1/16 x 3/8	—	0.500	1.875	2.125	0.9	1.7
2517	11,600	3.375	1.750	3.250	2	1/2 x 1	—	0.500	2.250	2.688	1.8	3.7
3020	24,000	4.250	2.000	4.000	2	5/8 x 1 1/4	—	0.875	2.750	3.250	3.3	6.5
3525	44,800	5.000	2.500	4.830	3	1/2 x 1 1/2	39	1.188	3.250	3.938	3.7	10.9
3535	44,800	5.000	3.500	4.830	3	1/2 x 1 1/2	39	1.188	3.250	3.938	5.0	14.8
4030	77,300	5.750	3.000	5.540	3	5/8 x 1 3/4	40	1.438	3.625	4.438	6.4	17.3
4040	77,300	5.750	4.000	5.540	3	5/8 x 1 3/4	40	1.438	3.625	4.438	8.2	22.1
4535	110,000	6.375	3.500	6.130	3	3/4 x 2	40	1.938	4.250	4.938	8.8	23.7
4545	110,000	6.375	4.500	6.130	3	3/4 x 2	40	1.938	4.250	4.938	11.2	30.3
5040	126,000	7.000	4.000	6.720	3	3/4 x 2 1/4	37	2.438	4.500	5.000	15.9	31.5
6050	282,000	9.250	5.000	9.000	3	1 1/4 x 3 1/2	—	4.438	6.000	—	45.0	57.0
7060	416,000	10.250	6.000	10.000	4	1 1/4 x 3 1/2	—	4.938	7.000	—	66.0	87.0

* Registered trademark of Reliance Electric. ** Key is furnished with each bushing having a shallow keyseat.

*** Keys are not furnished with bushings having standard keyseats.



Stock Bushings for Sprockets — continued

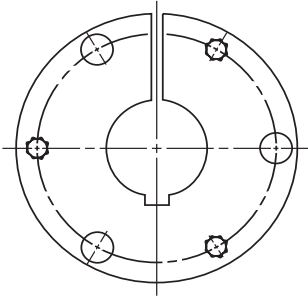

Style E to J

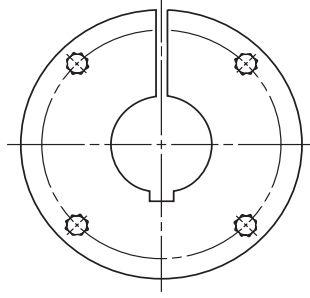

Style M through S

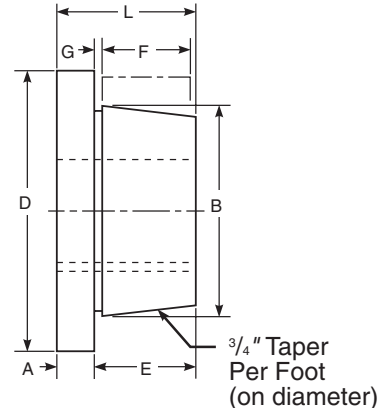

QD Bushings

Bushing Size	Torque Capacity (lb-in)	Dimensions (in)							Bolt Circle	Cap Screws		Bore Range (in)		Weight Range (lb)	
		A	B	D	E	F	G	L		No.	Size	Min.	Max.	Max. Bore	Min. Bore
E	20,000	0.875	3.825	6.000	1.875	1.625	0.250	2.750	5.000	3	$\frac{1}{2}$ -13 x $2\frac{3}{4}$	0.875	3.500	9.0	12.3
F	30,000	1.000	4.438	6.625	2.844	2.500	0.344	3.750	5.625	3	$\frac{5}{16}$ -12 x $3\frac{5}{8}$	1.000	4.000*	8.5	19.5
J	45,000	1.125	5.141	7.250	3.563	3.188	0.375	4.625	6.250	3	$\frac{3}{8}$ -11 x $4\frac{1}{2}$	1.438	4.500**	12.8	29.7
M	85,000	1.250	6.500	9.000	5.594	5.188	0.406	6.750	7.875	4	$\frac{3}{4}$ -10 x $6\frac{3}{4}$	2.000	5.500**	47.8	63.8
N	150,000	1.500	7.000	10.000	6.813	6.250	0.563	8.125	8.500	4	$\frac{7}{8}$ -9 x 8	2.438	6.000**	48.0	94.0
P	250,000	1.750	8.250	11.750	7.875	7.250	0.625	9.375	10.000	4	1-8 x $9\frac{1}{2}$	2.938	7.000**	69.5	133.0
W	375,000	2.000	10.422	15.000	9.500	9.000	0.500	11.375	12.750	4	$1\frac{1}{8}$ -7 x $11\frac{1}{2}$	4.000	8.500**	164.0	262.0
S	625,000	2.750	12.125	17.750	12.750	12.000	0.750	15.250	15.000	5	$1\frac{1}{4}$ -7 x 15	5.500	10.000**	133.0	350.0

* Maximum bore without keyway

Bushing Bore and Keyseat Information

Taper Lock and QD Bushings are available from stock with all popular bores within the bore range of each size bushing.

The Taper Lock and QD Bushing Keyseat Dimension charts below list the bore range for each bushing and the appropriate keyseat dimensions.

Where standard keyseats are indicated, refer to the Standard Keyseat Dimensions chart. Where bores do not permit standard depth keyseats, a flat key of the proper dimensions is furnished with the bushing.

Taper-Lock Bushing Keyseat Dimensions

Bushing	Bores (in)	Keyseat
1008	0.500 - 0.875	Standard
	0.938 - 1.000	$\frac{1}{4} \times \frac{1}{16}$
1108	0.500 - 1.000	Standard
	1.062 - 1.125	$\frac{1}{4} \times \frac{1}{16}$
1210	0.500 - 1.250	Standard
1610	0.500 - 1.500	Standard
	1.563 - 1.688	$\frac{3}{8} \times \frac{1}{8}$
1615	0.500 - 1.500	Standard
	1.563 - 1.688	$\frac{3}{8} \times \frac{1}{8}$
2012	0.500 - 1.875	Standard
	1.938 - 2.125	$\frac{1}{2} \times \frac{3}{16}$
2517	0.500 - 2.250	Standard
	2.313 - 2.688	$\frac{5}{8} \times \frac{3}{16}$
3020	0.875 - 2.750	Standard
	2.813 - 3.250	$\frac{3}{4} \times \frac{1}{4}$
3525	1.188 - 3.250	Standard
	3.313 - 3.750	$\frac{7}{8} \times \frac{1}{4}$
	3.875 - 3.938	$1 \times \frac{1}{4}$
3535	1.188 - 3.250	Standard
	3.313 - 3.750	$\frac{7}{8} \times \frac{1}{4}$
	3.875 - 3.938	$1 \times \frac{1}{4}$
4030	1.438 - 3.625	Standard
	3.688 - 3.750	$\frac{7}{8} \times \frac{1}{4}$
	3.875 - 4.438	$1 \times \frac{1}{4}$
4040	1.438 - 3.625	Standard
	3.688 - 3.750	$\frac{7}{8} \times \frac{1}{4}$
	3.875 - 4.438	$1 \times \frac{1}{4}$
4535	1.938 - 4.250	Standard
	4.375 - 4.500	$1 \times \frac{1}{4}$
	4.750 - 4.938	$1\frac{1}{4} \times \frac{1}{4}$
4545	1.938 - 4.250	Standard
	4.375 - 4.500	$1 \times \frac{1}{4}$
	4.750 - 4.938	$1\frac{1}{4} \times \frac{1}{4}$
5040	2.438 - 4.500	Standard
	4.875 - 5.000	$1\frac{1}{4} \times \frac{1}{16}$
6050	4.438 - 6.000	Standard
7060	4.938 - 7.000	Standard

QD Bushing Keyseat Dimensions

Bushing	Bores (in)	Keyseat
E	0.875 - 2.875	Standard
	2.938 - 3.250	$\frac{3}{4} \times \frac{1}{8}$
	3.375 - 3.500	$\frac{7}{8} \times \frac{1}{16}$
F	1.000 - 3.250	Standard
	3.375 - 3.750	$\frac{7}{8} \times \frac{3}{16}$
	3.875 - 3.938	$1 \times \frac{1}{8}$
J	1.500 - 3.750	Standard
	3.875 - 4.500	$1 \times \frac{1}{8}$
M	2.000 - 4.750	Standard
	4.875 - 5.500	$1\frac{1}{4} \times \frac{1}{4}$
N	2.438 - 5.000	Standard
	5.125 - 5.500	$1\frac{1}{4} \times \frac{1}{4}$
P	5.625 - 6.000	$1\frac{1}{2} \times \frac{1}{8}$
	2.938 - 5.938	Standard
	6.000 - 6.500	$1\frac{1}{2} \times \frac{1}{4}$
W	7.000	$1\frac{3}{4} \times \frac{1}{4}$
	4.000 - 8.000	Made to order
S	5.500 - 10.000	Made to order

Standard Keyseat Dimensions

Shaft Diameter (in)	Keyseat (in)		Key (in)	
	Width	Depth	Width	Depth
0.313 - 0.438	$\frac{3}{32}$	$\frac{3}{64}$	$\frac{3}{32}$	$\frac{3}{32}$
0.500 - 0.563	$\frac{1}{8}$	$\frac{1}{16}$	$\frac{1}{8}$	$\frac{1}{8}$
0.625 - 0.875	$\frac{3}{16}$	$\frac{7}{32}$	$\frac{3}{16}$	$\frac{3}{16}$
0.938 - 1.250	$\frac{1}{4}$	$\frac{1}{8}$	$\frac{1}{4}$	$\frac{1}{4}$
1.313 - 1.375	$\frac{5}{16}$	$\frac{5}{32}$	$\frac{5}{16}$	$\frac{5}{16}$
1.438 - 1.750	$\frac{3}{8}$	$\frac{3}{16}$	$\frac{3}{8}$	$\frac{3}{8}$
1.813 - 2.250	$\frac{1}{2}$	$\frac{1}{4}$	$\frac{1}{2}$	$\frac{1}{2}$
2.313 - 2.750	$\frac{5}{8}$	$\frac{5}{16}$	$\frac{5}{8}$	$\frac{5}{8}$
2.813 - 3.250	$\frac{3}{4}$	$\frac{3}{8}$	$\frac{3}{4}$	$\frac{3}{4}$
3.313 - 3.750	$\frac{7}{8}$	$\frac{7}{16}$	$\frac{7}{8}$	$\frac{7}{8}$
3.813 - 4.500	1	$\frac{1}{2}$	1	1
4.563 - 5.500	$1\frac{1}{4}$	$\frac{3}{8}$	$1\frac{1}{4}$	$1\frac{1}{4}$
5.563 - 6.500	$1\frac{1}{2}$	$\frac{3}{4}$	$1\frac{1}{2}$	$1\frac{1}{2}$
6.563 - 7.500	$1\frac{3}{4}$	$\frac{3}{4}$	$1\frac{3}{4}$	$1\frac{1}{2}$
7.563 - 9.000	2	$\frac{3}{4}$	2	$1\frac{1}{2}$



Specifying English and Metric Keyways

Dimensioning and specifying metric keys and keyways varies significantly from the English system. In the English system, it is the standard practice to dimension the keyway, while in the metric system it is common practice to specify the key size. In the English system, the keyway in the hub is dimensioned by the width and depth at the side, but in the metric system the keyway is dimensioned by the width and the depth measured from the radius of the shaft to the center of the keyway. One of the following methods should be used to specify keyways:

English:	Metric:
W x T ₁ Keyway	W x T Key
W x T Key	W x h Keyway

Unless otherwise noted, the keyway in the shaft is assumed to be standard. Also, T₁ and T₂ are not necessarily equal.

The metric system does not refer to keyseat or keyway dimensions as does the English system. Instead, dimensions are given for the key itself which is rectangular in shape, not square, as in the English system. The correct terminology when ordering metric bored bushings with millimeter keyways will be either of the following:

1. Specify "standard Keyway"
2. Customer to specify keysize (keyseat to be standard size in shaft)

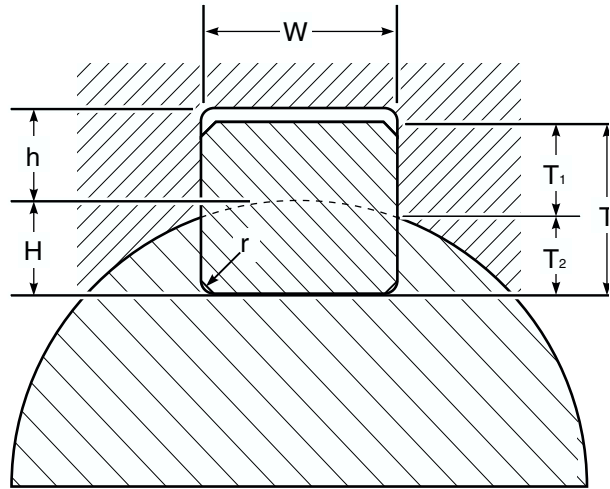

Metric Bore and Key Dimensions for Taper-Lock Bushings

Bushing	Bore (mm)	Keyway (WxT) (mm)	Key Size (ref.) (mm)
1008	14, 16	5 X 2.3	5 X 5
	18, 19, 20, 22	6 X 2.8	6 X 6
	24	8 X 3.3	8 X 7
1108	14*, 16	5 X 2.3	5 X 5
	18, 19, 20, 22	6 X 2.8	6 X 6
	24, 25	8 X 3.3	8 X 7
1210	14, 16	5 X 2.3	5 X 5
	18, 19, 20, 22*	6 X 2.8	6 X 6
	24, 25, 28, 30	8 X 3.3	8 X 7
1610	14*, 16*	5 X 2.3	5 X 5
	18*, 19, 20, 22	6 X 2.8	6 X 6
	24, 25, 28, 30	8 X 3.3	8 X 7
	32, 35, 38	10 X 3.3	10 X 8
	40	12 X 3.3	12 X 8
2012	14, 16	5 X 2.3	5 X 5
	18, 19, 20, 22	6 X 2.8	6 X 6
	24, 25, 28, 30	8 X 3.3	8 X 7
	32, 35, 38	10 X 3.3	10 X 8
	40, 42	12 X 3.3	12 X 8
	45, 48*	14 X 3.8	14 X 9
2517	14, 16	5 X 2.3	5 X 5
	18, 19*, 20, 22	6 X 2.8	6 X 6
	24, 25, 28, 30	8 X 3.3	8 X 7
	32, 35, 38	10 X 3.3	10 X 8
	40, 42	12 X 3.3	12 X 8
	45, 48, 50	14 X 3.8	14 X 9
	55	16 X 4.3	16 X 10
60, 65*	18 X 4.4	18 X 11	
3020	24, 25, 28, 30*	8 X 3.3	8 X 7
	32*, 35*, 38*	10 X 3.3	10 X 8
	40, 42*	12 X 3.3	12 X 8
	45, 48, 50	14 X 3.8	14 X 9
	55	16 X 4.3	16 X 10
	60, 65	18 X 4.4	18 X 11
	70*, 75*	20 X 4.9	20 X 12

* Non-stock, made to order bushing

Taper-Lock Type Sprocket Installation and Removal

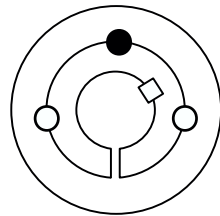

1008 to 3020

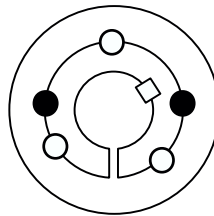

3525 to 6050

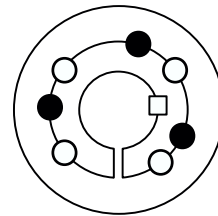

7060

To Install TAPER-LOCK Type Bushings

1. Clean the shaft, bore of bushing, outside of bushing and the sprocket hub bore of all oil, paint and dirt. File away any burrs.

Note: The use of lubricants can cause sprocket breakage. USE NO LUBRICANTS IN THIS INSTALLATION.

2. Insert the bushing into the sprocket hub. Match the hole pattern, not threaded holes (each complete hole will be threaded on one side only).
3. LIGHTLY oil the set screws and thread them into those half-threaded holes indicated by on the diagram above.

Note: Do not lubricate the bushing taper, hub taper, bushing bore, or the shaft. Doing so could result in sprocket breakage.

4. With the key in the shaft keyway, position the assembly onto the shaft allowing for small axial movement of the sprocket which will occur during the tightening process.

Note: When mounting sprockets on a vertical shaft, precautions must be taken to positively prevent the sprocket and/or bushing from falling during installation.

5. Alternately torque the set screws until the sprocket and bushing tapers are completely seated together (at approximately half of the recommended torque; see table below).

Note: Do not use worn hex key wrenches. Doing so may result in a loose assembly or may damage screws.

6. Check the alignment and sprocket axial runout (wobble), and correct as necessary.
7. Continue alternate tightening of the cap screws to the recommended torque values specified in the table below.
8. To increase the bushing gripping force, hammer the face of the bushing using a drift or sleeve (Do Not Hit The Bushing Directly With The Hammer).
9. Re-torque the bushing screws after hammering.
10. Recheck all screw torque values after the initial drive run-in, and periodically thereafter. Repeat steps 5 through 9 if loose.

To Remove

1. Loosen and remove all mounting screws.
2. Insert screws into all jack screw holes indicated by "●" (see figure above).
3. Loosen the bushing by alternately tightening the screws in small but equal increments until the tapered sprocket and bushing surfaces disengage.

Sprocket Installation

Bushing Style	Bolts		Torque Wrench	
	Qty.	Size	lb-ft	lb-in
1008	2	1/4-20 x 1/2	4.6	55
1108	2	1/4-20 x 1/2	4.6	55
1210	2	3/8-16 x 5/8	14.6	175
1610	2	3/8-16 x 5/8	14.6	175
1615	2	3/8-16 x 5/8	14.6	175
2012	2	7/16-14 x 7/8	23.3	280
2517	2	1/2-13 x 1	35.8	430
3020	2	5/8-11 x 1 1/4	66.7	800
3525	3	1/2-13 x 1 1/2	83.3	1000
3535	3	1/2-13 x 1 1/2	83.3	1000
4030	3	5/8-11 x 1 3/4	141.7	1700
4040	3	5/8-11 x 1 3/4	142	1700
4535	3	3/4-10 x 2	204.2	2450
4545	3	3/4-10 x 2	204	2450
5040	3	7/8-9 x 2 1/4	258	3100
6050	3	1 1/4-7 x 3 1/2	652	7820
7060	4	1 1/4-7 x 3 1/2	652	7820

Caution: Excessive bolt torque can cause sprocket and/or bushing breakage.

Note: To insure proper bushing/sprocket performance, full bushing contact on the shaft is recommended.

QD Type Sprocket Installation and Removal



Conventional Mount



Reverse Mount

To Install QD Type Bushings

1. Clean the shaft, bore of bushing, outside of bushing and the sprocket hub bore of all oil, paint and dirt. File away any burrs.

Note: The use of lubricants can cause sprocket breakage. USE NO LUBRICANTS IN THIS INSTALLATION.

2. For Position One or Position Two (whichever applies), line up the unthreaded bushing holes C with the threaded sprocket hub holes T. Lightly oil the cap screws and thread them (with lock washers) into the sprocket hub engaging only 2 or 3 threads. Screw heads should be mounted outside to allow for disassembly. When mounting sprockets on M through W bushing sizes, position the threaded jack screw hole (J) as far from the bushing saw slot as possible to reduce the possibility of bushing breakage during disassembly.

Note: Do not lubricate the bushing taper, hub taper, bushing bore, or the shaft. Doing so could result in sprocket breakage.

3. With the key in the shaft keyway, position the assembly onto the shaft allowing for small axial movement of the sprocket which will occur during the tightening process. When installing large or heavy parts in Position One (see figure above), it may be easier to mount the key and bushing onto the shaft

first then place the sprocket on the bushing and align the holes.

Note: When mounting sprockets on a vertical shaft, precautions must be taken to positively prevent the sprocket and/or bushing from falling during installation.

4. Alternately tighten the cap screws until the sprocket and bushing tapers are completely seated together (at approximately half the recommended torque).
5. Check the alignment and sprocket runout (wobble), and correct as necessary.
6. Continue alternate tightening of the cap screws to the recommended torque values specified in the table below.

Note: Excessive cap screw torque can cause sprocket and/or bushing breakage. When properly mounted, there must be a gap between bushing flange and sprocket after the screws are tightened.

7. Tighten the set screw, when available, to hold the key securely during operation.

To Remove

1. Loosen and remove all mounting screws.
2. Insert cap screws into all threaded jack screw holes J (see figure above).
3. Loosen the bushing by first tightening the screw furthest from the bushing saw slot, then alternately tighten remaining screws. Keep tightening the screws in small but equal incre-

ments until the tapered sprocket and bushing surfaces disengage.

Note: Excessive or unequal pressure on the cap screws can break the bushing flange, making removal nearly impossible without destroying the sprocket.

Sprocket Installation

Bushing Style	Bolts		Torque Wrench	
	Qty.	Size	lb-ft	lb-in
H	2	1/4 x 3/4	7.9	95
JA	3	10-24 x 1	4.5	54
SH & SDS	3	1/4-20 x 1 3/8	9.0	108
SD	3	1/4-20 x 1 7/8	9.0	108
SK	3	5/16-18 x 2	15.0	180
SF	3	3/8-16 x 2	30.0	360
E	3	1/2-13 x 2 3/4	60.0	720
F	3	9/16-12 x 3 5/8	75.0	900
J	3	5/8-11 x 4 1/2	135.0	1620
M	4	3/4-10 x 6 3/4	225.0	2700
N	4	7/8-9 x 8	300.0	3600
P	4	1-8 x 9 1/2	450.0	5400
W	4	1 1/8-7 x 11 1/2	600.0	7200
S	5	1 1/4-7 x 15 1/2	750.0	9000

Caution: Excessive bolt torque can cause sprocket and/or bushing breakage.

Note: To insure proper bushing/sprocket performance, full bushing contact on the shaft is recommended.

Belt Drive Tensioners

(Double Adjustable)

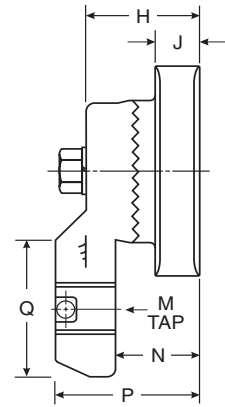
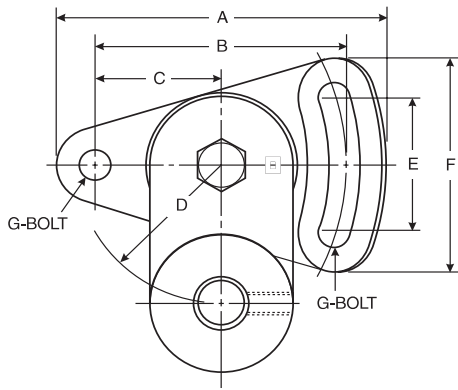

Specifications

Tensioner Product No.	Part No.	A (in)	B (in)	C (in)	D (in)	E (in)	F (in)	G (in)	H (in)	J (in)	M (Threads)	N (in)	P (in)	Q (in)	Weight (lb)
7720-2010	10-IDL-BRAK2	4.63	3.50	1.75	2.00	2.06	3.06	0.38	1.50	0.56	3/4-16	1.00	1.88	1.75	2.7
7720-2020	20-IDL-BRAK2	6.94	5.25	2.63	5.00	3.00	4.56	0.63	2.38	1.00	1-14	1.63	2.94	2.75	10.8

Sprocket Specification Tables

5mm Pitch Sprocket Diameters

No. of Grooves	mm (in)		No. of Grooves	mm (in)		No. of Grooves	mm (in)		No. of Grooves	mm (in)		No. of Grooves	mm (in)	
	P.D.	O.D.		P.D.	O.D.		P.D.	O.D.		P.D.	O.D.		P.D.	O.D.
18	28.65 1.128	27.51 1.083	47	74.80 2.945	73.66 2.900	76	120.96 4.762	119.82 4.717	105	167.11 6.579	165.97 6.534	134	213.27 8.396	212.13 8.351
19	30.24 1.191	29.10 1.146	48	76.39 3.008	75.25 2.963	77	122.55 4.825	121.41 4.780	106	168.70 6.642	167.56 6.597	135	214.86 8.459	213.72 8.414
20	31.83 1.253	30.69 1.208	49	77.99 3.070	76.85 3.025	78	124.14 4.887	123.00 4.842	107	170.30 6.705	169.16 6.660	136	216.45 8.522	215.31 8.477
21	33.42 1.316	32.28 1.271	50	79.58 3.133	78.44 3.088	79	125.73 4.950	124.59 4.905	108	171.89 6.767	170.75 6.722	137	218.04 8.584	216.90 8.539
22	35.01 1.379	33.87 1.334	51	81.17 3.196	80.03 3.151	80	127.32 5.013	126.18 4.968	109	173.48 6.830	172.34 6.785	138	219.63 8.647	218.49 8.602
23	36.61 1.441	35.47 1.396	52	82.76 3.258	81.62 3.213	81	128.92 5.075	127.78 5.030	110	175.07 6.893	173.93 6.848	139	221.23 8.710	220.09 8.665
24	38.20 1.504	37.06 1.459	53	84.35 3.321	83.21 3.276	82	130.51 5.138	129.37 5.093	111	176.66 6.955	175.52 6.910	140	222.82 8.772	221.68 8.727
25	39.79 1.566	38.65 1.521	54	85.94 3.384	84.80 3.339	83	132.10 5.201	130.96 5.156	112	178.25 7.018	177.11 6.973	141	224.41 8.835	223.27 8.790
26	41.38 1.629	40.24 1.584	55	87.54 3.446	86.40 3.401	84	133.69 5.263	132.55 5.218	113	179.85 7.081	178.71 7.036	142	226.00 8.898	224.86 8.853
27	42.97 1.692	41.83 1.647	56	89.13 3.509	87.99 3.464	85	135.28 5.326	134.14 5.281	114	181.44 7.143	180.30 7.098	143	227.59 8.960	226.45 8.915
28	44.56 1.754	43.42 1.709	57	90.72 3.572	89.58 3.527	86	136.87 5.389	135.73 5.344	115	183.03 7.206	181.89 7.161	144	229.18 9.023	228.04 8.978
29	46.15 1.817	45.01 1.772	58	92.31 3.634	91.17 3.589	87	138.46 5.451	137.32 5.406	116	184.62 7.268	183.48 7.223	145	230.77 9.086	229.63 9.041
30	47.75 1.880	46.61 1.835	59	93.90 3.697	92.76 3.652	88	140.06 5.514	138.92 5.469	117	186.21 7.331	185.07 7.286	146	232.37 9.148	231.23 9.103
31	49.34 1.942	48.20 1.897	60	95.49 3.760	94.35 3.715	89	141.65 5.577	140.51 5.532	118	187.80 7.394	186.66 7.349	147	233.96 9.211	232.82 9.166
32	50.93 2.005	49.79 1.960	61	97.08 3.822	95.94 3.777	90	143.24 5.639	142.10 5.594	119	189.39 7.456	188.25 7.411	148	235.55 9.274	234.41 9.229
33	52.52 2.068	51.38 2.023	62	98.68 3.885	97.54 3.840	91	144.83 5.702	143.69 5.657	120	190.99 7.519	189.85 7.474	149	237.14 9.336	236.00 9.291
34	54.11 2.130	52.97 2.085	63	100.27 3.948	99.13 3.903	92	146.42 5.765	145.28 5.720	121	192.58 7.582	191.44 7.537	150	238.73 9.399	237.59 9.354
35	55.70 2.193	54.56 2.148	64	101.86 4.010	100.72 3.965	93	148.01 5.827	146.87 5.782	122	194.17 7.644	193.03 7.599	151	240.32 9.462	239.18 9.417
36	57.30 2.256	56.16 2.211	65	103.45 4.073	102.31 4.028	94	149.61 5.890	148.47 5.845	123	195.76 7.707	194.62 7.662	152	241.92 9.524	240.78 9.479
37	58.89 2.318	57.75 2.273	66	105.04 4.136	103.90 4.091	95	151.20 5.953	150.06 5.908	124	197.35 7.770	196.21 7.725	153	243.51 9.587	242.37 9.542
38	60.48 2.381	59.34 2.336	67	106.63 4.198	105.49 4.153	96	152.79 6.015	151.65 5.970	125	198.94 7.832	197.80 7.787	154	245.10 9.650	243.96 9.605
39	62.07 2.444	60.93 2.399	68	108.23 4.261	107.09 4.216	97	154.38 6.078	153.24 6.033	126	200.54 7.895	199.40 7.850	155	246.69 9.712	245.55 9.667
40	63.66 2.506	62.52 2.461	69	109.82 4.324	108.68 4.279	98	155.97 6.141	154.83 6.096	127	202.13 7.958	200.99 7.913	156	248.28 9.775	247.14 9.730
41	65.25 2.569	64.11 2.524	70	111.41 4.386	110.27 4.341	99	157.56 6.203	156.42 6.158	128	203.72 8.020	202.58 7.975	157	249.87 9.838	248.73 9.793
42	66.85 2.632	65.71 2.587	71	113.00 4.449	111.86 4.404	100	159.15 6.266	158.01 6.221	129	205.31 8.083	204.17 8.038	158	251.46 9.900	250.32 9.855
43	68.44 2.694	67.30 2.649	72	114.59 4.511	113.45 4.466	101	160.75 6.329	159.61 6.284	130	206.90 8.146	205.76 8.101	159	253.06 9.963	251.92 9.918
44	70.03 2.757	68.89 2.712	73	116.18 4.574	115.04 4.529	102	162.34 6.391	161.20 6.346	131	208.49 8.208	207.35 8.163	160	254.65 10.026	253.51 9.981
45	71.62 2.820	70.48 2.775	74	117.77 4.637	116.63 4.592	103	163.93 6.454	162.79 6.409	132	210.08 8.271	208.94 8.226			
46	73.21 2.882	72.07 2.837	75	119.37 4.699	118.23 4.654	104	165.52 6.517	164.38 6.472	133	211.68 8.334	210.54 8.289			

See Page 116 for sprocket O.D. tolerances.



Sprocket Specification Tables

8mm Pitch Sprocket Diameters

No. of Grooves	mm (in)		No. of Grooves	mm (in)		No. of Grooves	mm (in)		No. of Grooves	mm (in)		No. of Grooves	mm (in)	
	P.D.	O.D.		P.D.	O.D.		P.D.	O.D.		P.D.	O.D.		P.D.	O.D.
22	56.02 2.206	54.65 2.152	56	142.60 5.614	141.23 5.560	90	229.18 9.023	227.81 8.969	124	315.76 12.432	314.39 12.378	158	402.34 15.840	400.97 15.786
23	58.57 2.306	57.20 2.252	57	145.15 5.715	143.78 5.660	91	231.73 9.123	230.36 9.069	125	318.31 12.532	316.94 12.478	159	404.89 15.941	403.52 15.887
24	61.12 2.406	59.74 2.352	58	147.70 5.815	146.32 5.761	92	234.28 9.223	232.90 9.169	126	320.86 12.632	319.48 12.578	160	407.44 16.041	406.07 15.987
25	63.66 2.506	62.29 2.452	59	150.24 5.915	148.87 5.861	93	236.82 9.324	235.45 9.270	127	323.41 12.733	322.03 12.678	161	409.98 16.141	408.61 16.087
26	66.21 2.607	64.84 2.553	60	152.79 6.015	151.42 5.961	94	239.37 9.424	238.00 9.370	128	325.95 12.833	324.58 12.779	162	412.53 16.241	411.16 16.187
27	68.75 2.707	67.38 2.653	61	155.34 6.116	153.96 6.062	95	241.92 9.524	240.54 9.470	129	328.50 12.933	327.12 12.879	163	415.08 16.342	413.70 16.288
28	71.30 2.807	69.93 2.753	62	157.88 6.216	156.51 6.162	96	244.46 9.624	243.09 9.570	130	331.04 13.033	329.67 12.979	164	417.62 16.442	416.25 16.388
29	73.85 2.907	72.48 2.853	63	160.43 6.316	159.06 6.262	97	247.01 9.725	245.64 9.671	131	333.59 13.133	332.22 13.079	165	420.17 16.542	418.80 16.488
30	76.39 3.008	75.02 2.954	64	162.97 6.416	161.60 6.362	98	249.55 9.825	248.18 9.771	132	336.14 13.234	334.76 13.180	166	422.72 16.642	421.34 16.588
31	78.94 3.108	77.57 3.054	65	165.52 6.517	164.15 6.463	99	252.10 9.925	250.73 9.871	133	338.68 13.334	337.31 13.280	167	425.26 16.743	423.89 16.689
32	81.49 3.208	80.12 3.154	66	168.07 6.617	166.70 6.563	100	254.65 10.025	253.28 9.971	134	341.23 13.434	339.86 13.380	168	427.81 16.843	426.44 16.789
33	84.03 3.308	82.66 3.254	67	170.61 6.717	169.24 6.663	101	257.19 10.126	255.82 10.072	135	343.77 13.534	342.40 13.480	169	430.35 16.943	428.98 16.889
34	86.58 3.409	85.21 3.355	68	173.16 6.817	171.79 6.763	102	259.74 10.226	258.37 10.172	136	346.32 13.635	344.95 13.581	170	432.90 17.043	431.53 16.989
35	89.13 3.509	87.76 3.455	69	175.71 6.918	174.34 6.864	103	262.29 10.326	260.92 10.272	137	348.87 13.735	347.50 13.681	171	435.45 17.144	434.08 17.090
36	91.67 3.609	90.30 3.555	70	178.25 7.018	176.88 6.964	104	264.83 10.427	263.46 10.372	138	351.41 13.835	350.04 13.781	172	437.99 17.244	436.62 17.190
37	94.22 3.709	92.85 3.655	71	180.80 7.118	179.43 7.064	105	267.38 10.527	266.01 10.473	139	353.96 13.935	352.59 13.881	173	440.54 17.344	439.17 17.290
38	96.77 3.810	95.39 3.756	72	183.35 7.218	181.97 7.164	106	269.93 10.628	268.56 10.573	140	356.51 14.036	355.14 13.982	174	443.09 17.444	441.72 17.390
39	99.31 3.910	97.94 3.856	73	185.89 7.319	184.52 7.265	107	272.47 10.728	271.10 10.673	141	359.05 14.136	357.68 14.082	175	445.63 17.544	444.26 17.491
40	101.86 4.010	100.49 3.956	74	188.44 7.419	187.07 7.365	108	275.02 10.828	273.65 10.771	142	361.60 14.236	360.23 14.182	176	448.18 17.645	446.81 17.591
41	104.41 4.110	103.03 4.056	75	190.99 7.519	189.61 7.465	109	277.57 10.928	276.19 10.874	143	364.15 14.336	362.77 14.282	177	450.73 17.745	449.36 17.691
42	106.95 4.211	105.58 4.157	76	193.53 7.619	192.16 7.565	110	280.11 11.028	278.74 10.974	144	366.69 14.437	365.32 14.383	178	453.27 17.845	451.90 17.791
43	109.50 4.311	108.13 4.257	77	196.08 7.720	194.71 7.666	111	282.66 11.128	281.29 11.074	145	369.24 14.537	367.87 14.483	179	455.82 17.946	454.45 17.892
44	112.05 4.411	110.67 4.357	78	198.63 7.820	197.25 7.766	112	285.21 11.229	283.83 11.175	146	371.79 14.637	370.41 14.583	180	458.37 18.046	456.99 17.992
45	114.59 4.511	113.22 4.457	79	201.17 7.920	199.81 7.866	113	287.75 11.329	286.38 11.275	147	374.33 14.737	372.96 14.683	181	460.91 18.146	459.54 18.092
46	117.14 4.612	115.77 4.558	80	203.72 8.020	202.35 7.966	114	290.30 11.429	288.93 11.375	148	376.88 14.838	375.51 14.784	182	463.46 18.246	462.09 18.192
47	119.68 4.712	118.31 4.658	81	206.26 8.121	2.4.89 8.067	115	292.85 11.529	291.47 11.475	149	379.43 14.938	378.05 14.884	183	466.01 18.347	464.63 18.293
48	122.23 4.812	120.86 4.758	82	208.81 8.221	207.44 8.167	116	295.39 11.630	294.02 11.576	150	381.97 15.038	380.60 14.984	184	468.55 18.447	467.18 18.393
49	124.78 4.912	123.41 4.858	83	211.36 8.321	209.99 8.267	117	297.94 11.730	296.57 11.676	151	384.52 15.138	353.15 15.084	185	471.10 18.547	469.73 18.493
50	127.32 5.013	125.95 4.959	84	213.90 8.421	212.53 8.367	118	300.48 11.830	299.11 11.776	152	387.06 15.239	385.70 15.185	186	473.65 18.647	472.27 18.593
51	129.87 5.113	128.50 5.059	85	216.45 8.522	215.08 8.468	119	303.03 11.930	301.66 11.876	153	389.61 15.339	388.24 15.285	187	476.19 18.748	474.82 18.694
52	132.42 5.213	131.05 5.159	86	219.00 8.622	217.63 8.568	120	305.58 12.031	304.21 11.977	154	392.16 15.439	390.79 15.385	188	478.74 18.848	477.37 18.794
53	134.96 5.314	133.59 5.259	87	221.54 8.722	220.17 8.668	121	308.12 12.131	306.75 12.077	155	394.70 15.510	393.33 15.486	189	481.28 18.948	479.91 18.894
54	137.51 5.414	136.14 5.360	88	224.09 8.822	222.72 8.768	122	310.67 12.231	309.30 12.177	156	397.25 15.640	395.88 15.586	190	483.83 19.048	482.46 18.994
55	140.06 5.514	138.68 5.460	89	226.64 8.923	225.27 8.869	123	313.22 12.331	311.85 12.277	157	399.80 15.740	398.43 15.686	191	486.38 19.149	485.01 19.095

See Page 116 for sprocket O.D. Tolerances.



Sprocket Specification Tables

14mm Pitch Sprocket Diameters

No. of Grooves	Diameters mm (in)		No. of Grooves	Diameters mm (in)		No. of Grooves	Diameters mm (in)		No. of Grooves	Diameters mm (in)		No. of Grooves	Diameters mm (in)	
	P.D.	O.D.		P.D.	O.D.		P.D.	O.D.		P.D.	O.D.		P.D.	O.D.
28	124.78 4.912	121.98 4.802	65	289.66 11.404	286.87 11.294	102	454.55 17.895	451.75 17.785	139	619.43 24.387	616.64 24.277	176	784.32 30.878	781.52 30.768
29	129.23 5.088	126.44 4.978	66	294.12 11.579	291.32 11.469	103	459.00 18.071	456.21 17.961	140	623.89 24.562	621.09 24.452	177	788.77 31.054	785.98 30.944
30	133.69 5.263	130.90 5.153	67	298.57 11.755	295.78 11.645	104	463.46 18.246	460.66 18.136	141	628.34 24.738	625.55 24.628	178	793.23 31.228	790.43 31.119
31	138.15 5.439	135.35 5.329	68	303.03 11.930	300.24 11.820	105	467.92 18.422	465.12 18.312	142	632.80 24.913	630.01 24.803	179	797.68 31.405	794.89 31.295
32	142.60 5.614	139.81 5.504	69	307.49 12.106	304.69 11.996	106	472.37 18.597	469.58 18.487	143	637.26 25.089	634.46 24.979	180	802.14 31.580	799.35 31.470
33	147.06 5.790	144.27 5.680	70	311.94 12.281	309.15 12.171	107	476.83 18.773	474.03 18.663	144	641.71 25.264	638.92 25.154	181	806.60 31.756	803.80 31.646
34	151.52 5.965	148.72 5.855	71	316.40 12.457	313.61 12.347	108	481.28 18.948	478.49 18.838	145	646.17 25.440	643.37 25.330	182	811.05 31.931	808.26 31.821
35	155.98 6.141	153.18 6.031	72	320.86 12.632	318.06 12.522	109	485.74 19.124	482.95 19.014	146	650.63 25.615	647.83 25.505	183	815.51 32.107	812.72 31.997
36	160.43 6.316	157.63 6.206	73	325.31 12.808	322.52 12.698	110	490.20 19.299	487.40 19.189	147	655.08 25.791	652.29 25.681	184	819.97 32.252	817.17 32.172
37	164.88 6.492	162.09 6.382	74	329.77 12.983	326.97 12.873	111	494.65 19.475	491.86 19.365	148	659.54 25.966	656.74 25.856	185	824.42 32.458	821.63 32.348
38	169.34 6.667	166.55 6.557	75	334.22 13.158	331.43 13.048	112	499.11 19.650	496.32 19.540	149	663.99 26.141	661.20 26.031	186	828.88 32.633	826.08 32.523
39	173.80 6.842	171.00 6.732	76	338.68 13.334	335.89 13.224	113	503.57 19.825	500.77 19.715	150	668.45 26.317	665.66 26.207	187	833.33 32.808	830.54 32.698
40	178.25 7.018	175.46 6.908	77	343.14 13.509	340.34 13.399	114	508.2 20.001	505.23 19.891	151	672.91 26.492	670.11 26.382	188	837.79 32.954	835.00 32.874
41	182.71 7.193	179.92 7.083	78	347.59 13.685	344.80 13.575	115	512.48 20.176	509.68 20.056	152	677.36 26.668	674.57 26.558	189	842.25 33.159	839.45 33.049
42	187.17 7.369	184.37 7.259	79	352.05 13.860	349.26 13.750	116	516.93 20.352	514.14 20.242	153	681.82 26.843	679.03 26.733	190	846.70 33.335	843.91 33.225
43	191.62 7.544	188.83 7.434	80	356.51 14.036	353.71 13.926	117	521.39 20.527	518.60 20.417	154	686.28 27.019	683.48 26.909	191	851.16 33.510	848.37 33.400
44	196.08 7.720	193.28 7.610	81	360.96 14.211	358.17 14.101	118	525.85 20.703	523.05 20.593	155	690.73 27.194	687.94 27.084	192	855.62 33.686	852.82 33.576
45	200.53 7.895	197.74 7.785	82	365.42 14.387	362.63 14.277	119	530.30 20.878	527.51 20.768	156	695.19 27.370	692.39 27.260	193	860.07 33.861	857.28 33.751
46	204.99 8.071	202.20 7.961	83	369.88 14.562	367.08 14.452	120	534.76 21.054	531.97 20.944	157	699.64 27.545	696.85 27.435	194	864.53 34.037	861.75 33.927
47	209.45 8.246	206.65 8.136	84	374.33 14.737	371.54 14.627	121	539.22 21.229	536.42 21.119	158	704.10 27.720	701.31 27.610	195	868.98 34.212	866.44 34.112
48	213.90 8.421	211.11 8.311	85	378.79 14.913	375.99 14.803	122	543.67 21.404	540.88 21.294	159	708.56 27.896	705.76 27.786	196	873.44 34.387	870.64 34.277
49	218.36 8.597	215.57 8.487	86	383.24 15.068	380.45 14.978	123	548.13 21.580	545.34 21.470	160	713.01 28.071	710.22 27.961	197	877.90 34.553	875.11 34.453
50	222.82 8.772	220.02 8.662	87	387.70 15.264	384.91 15.154	124	552.59 21.755	549.79 21.645	161	717.47 28.247	714.68 28.137	198	882.35 34.738	879.55 34.628
51	227.27 8.948	224.48 8.838	88	392.16 15.439	389.36 15.329	125	557.04 21.931	554.25 21.821	162	721.93 28.422	719.13 28.312	199	886.81 34.914	884.02 34.804
52	231.73 9.123	228.94 9.013	89	396.61 15.615	393.82 15.505	126	561.50 22.106	558.70 21.996	163	726.38 28.598	723.59 28.488	200	891.27 35.089	888.47 34.979
53	236.19 9.299	233.39 9.189	90	401.07 15.790	398.28 15.680	127	565.95 22.282	563.16 22.172	164	730.84 28.773	728.05 28.663	201	895.72 35.265	892.94 35.155
54	240.64 9.474	237.85 9.364	91	405.53 15.966	402.73 15.856	128	570.41 22.457	567.62 22.347	165	735.30 28.949	732.50 28.839	202	900.18 35.440	897.38 35.330
55	245.10 9.650	242.30 9.540	92	409.98 16.141	407.19 16.031	129	574.87 22.633	572.07 22.523	166	739.75 29.124	736.96 29.014	203	904.64 35.616	901.85 35.506
56	249.55 9.825	246.76 9.715	93	414.44 16.316	411.64 16.206	130	579.32 22.808	576.53 22.689	167	744.21 29.299	741.41 29.189	204	909.09 35.791	906.30 35.681
57	254.01 10.000	251.22 9.890	94	418.90 16.492	416.10 16.382	131	583.78 22.983	580.99 22.873	168	748.66 29.475	745.87 29.365	205	913.55 35.966	910.74 35.856
58	258.47 10.176	255.67 10.066	95	423.35 16.667	420.56 16.557	132	588.24 23.159	585.44 23.049	169	753.12 29.650	750.33 29.540	206	918.00 36.142	915.21 36.032
59	262.92 10.351	260.13 10.241	96	427.81 16.843	425.01 16.733	133	592.69 23.334	589.90 23.224	170	757.58 29.826	754.78 29.716	207	922.46 36.317	919.66 36.207
60	267.38 10.527	264.59 10.417	97	432.26 17.018	429.47 16.908	134	597.15 23.510	594.35 23.400	171	762.03 30.001	759.24 29.891	208	926.92 36.493	924.13 36.383
61	271.84 10.702	269.04 10.592	98	436.72 17.194	433.93 17.084	135	601.61 23.685	598.81 23.575	172	766.49 30.177	763.70 30.067	209	931.37 36.668	928.57 36.558
62	276.29 10.878	273.50 10.768	99	441.18 17.369	438.38 17.259	136	606.06 23.861	603.27 23.751	173	770.95 30.352	768.15 30.242	210	935.83 36.844	933.04 36.734
63	280.75 11.053	277.95 10.943	100	445.63 17.545	442.84 17.435	137	610.52 24.036	607.72 23.926	174	775.40 30.528	772.61 30.418	211	940.29 37.019	937.49 36.909
64	285.21 11.229	282.41 11.119	101	450.09 17.720	447.30 17.610	138	614.97 24.212	612.18 24.102	175	779.86 30.703	777.06 30.593	212	944.74 37.195	941.96 37.085

See Page 116 for sprocket O.D. tolerances.



Sprocket Specification Tables

20mm Pitch Sprocket Diameters

No. of Grooves	mm (in)		No. of Grooves	mm (in)		No. of Grooves	mm (in)		No. of Grooves	mm (in)		No. of Grooves	mm (in)	
	P.D.	O.D.		P.D.	O.D.		P.D.	O.D.		P.D.	O.D.		P.D.	O.D.
34	216.45 8.522	212.13 8.352	70	445.63 17.545	441.32 17.375	106	674.82 26.568	670.50 26.398	142	904.00 35.591	899.68 35.421	178	1133.18 44.614	1128.87 44.444
35	222.82 8.772	218.50 8.602	71	452.00 17.795	447.68 17.625	107	681.18 26.818	676.87 26.648	143	910.37 35.841	906.05 35.671	179	1139.55 44.854	1135.23 44.694
36	229.18 9.023	224.87 8.853	72	458.37 18.046	454.05 17.876	108	687.55 27.069	683.23 26.899	144	916.73 36.092	912.41 35.922	180	1145.92 45.115	1141.60 44.945
37	235.55 9.274	231.23 9.104	73	464.73 18.297	460.41 18.127	109	693.92 27.320	689.60 27.150	145	923.10 36.342	918.78 36.172	181	1152.28 45.365	1147.96 45.195
38	241.92 9.524	237.60 9.354	74	471.10 18.547	466.78 18.377	110	700.28 27.570	695.96 27.400	146	929.46 36.593	925.15 36.423	182	1158.65 45.616	1154.33 45.446
39	248.28 9.775	243.96 9.605	75	477.46 18.798	473.15 18.628	111	706.65 27.821	702.33 27.651	147	935.83 36.84	931.51 36.674	183	1165.01 45.867	1160.70 45.697
40	254.65 10.026	250.33 9.855	76	483.83 19.048	479.51 18.878	112	713.01 28.071	708.70 27.901	148	942.20 37.094	937.88 36.924	184	1171.38 46.117	1167.06 45.947
41	261.01 10.276	256.70 10.106	77	490.20 19.299	485.88 19.129	113	719.38 28.322	715.06 28.152	149	948.56 37.345	944.25 37.175	185	1177.75 46.368	1173.43 46.198
42	267.38 10.527	263.06 10.357	78	496.56 19.550	492.25 19.380	114	725.75 28.573	721.43 28.403	150	954.93 37.596	950.61 37.426	186	1184.11 46.619	1179.79 46.449
43	273.75 10.777	269.43 10.607	79	502.93 19.800	498.61 19.630	115	732.11 28.823	727.79 28.653	151	961.30 37.846	956.98 37.676	187	1190.48 46.859	1186.16 46.699
44	280.11 11.028	275.79 10.858	80	509.30 20.051	504.98 19.881	116	738.48 29.074	734.16 28.904	152	967.66 38.097	963.34 37.927	188	1196.85 47.120	1192.53 46.950
45	286.48 11.279	282.16 11.109	81	515.66 20.302	511.34 20.132	117	744.85 29.325	740.53 29.155	153	974.03 38.348	969.71 38.178	189	1203.21 47.371	1198.89 47.201
46	292.85 11.529	288.53 11.469	82	522.03 20.552	517.71 20.382	118	751.21 29.575	746.89 29.405	154	980.39 38.598	976.08 38.428	190	1209.58 47.621	1205.26 47.451
47	299.21 11.780	294.89 11.610	83	528.39 20.803	524.08 20.633	119	757.58 29.826	753.26 29.656	155	986.76 38.849	982.44 38.679	191	1215.94 47.872	1211.63 47.702
48	305.58 12.031	301.26 11.861	84	534.76 21.054	530.44 20.884	120	763.94 30.077	759.63 29.907	156	993.13 39.099	988.81 38.929	192	1222.31 48.122	1217.99 47.952
49	311.94 12.281	307.63 12.111	85	541.13 21.304	536.81 21.134	121	770.31 30.327	765.99 30.157	157	999.49 39.350	995.18 39.180	193	1228.68 48.373	1224.36 48.203
50	318.31 12.532	313.99 12.362	86	547.49 21.555	543.18 21.385	122	776.68 30.578	772.36 30.408	158	1005.86 39.601	1001.54 39.431	194	1235.04 48.624	1230.72 48.454
51	324.68 12.763	320.36 12.613	87	553.86 21.805	549.54 21.635	123	783.04 30.828	778.72 30.658	159	1012.23 39.851	1007.91 39.681	195	1241.41 48.874	1237.09 48.704
52	331.04 13.033	326.72 12.863	88	560.23 22.056	555.91 21.886	124	789.41 31.079	785.09 30.909	160	1018.59 40.102	1014.27 39.932	196	1247.77 49.125	1243.46 48.955
53	337.41 13.284	333.09 13.114	89	566.59 22.307	562.27 22.137	125	795.77 31.330	791.46 31.160	161	1024.96 40.353	1020.64 40.183	197	1254.14 49.376	1249.82 49.206
54	343.77 13.534	339.46 13.364	90	572.96 22.557	568.64 22.387	126	802.14 31.580	797.82 31.410	162	1031.32 40.603	1027.01 40.433	198	1260.51 49.626	1256.19 49.456
55	350.14 13.785	345.82 13.615	91	579.32 22.808	575.01 22.638	127	808.51 31.831	804.19 31.661	163	1037.69 40.854	1033.37 40.684	199	1266.87 49.877	1262.56 49.707
56	356.51 14.036	352.19 13.856	92	585.69 23.059	581.37 22.889	128	814.87 32.082	810.56 31.912	164	1044.06 41.105	1039.74 40.935	200	1273.24 50.128	1268.92 49.958
57	362.87 14.286	358.56 14.116	93	592.06 23.309	587.74 23.139	129	821.24 32.332	816.92 32.162	165	1050.42 41.355	1046.10 41.185	201	1279.61 50.378	1275.29 50.208
58	369.24 14.537	364.92 14.367	94	598.42 23.560	594.10 23.390	130	827.61 32.583	823.29 32.413	166	1056.79 41.606	1052.47 41.436	202	1285.97 50.629	1281.65 50.459
59	375.61 14.788	371.29 14.618	95	604.72 23.811	600.47 23.641	131	833.97 32.834	829.65 32.664	167	1063.16 41.856	1058.84 41.686	203	1292.34 50.679	1288.02 50.709
60	381.97 15.038	377.65 14.868	96	611.15 24.061	606.84 23.891	132	840.34 33.084	836.02 32.914	168	1069.52 42.107	1065.20 41.937	204	1298.70 51.130	1294.39 50.960
61	388.34 15.289	384.02 15.119	97	617.52 24.312	613.20 24.142	133	846.70 33.335	842.39 33.165	169	1075.89 42.358	1071.57 42.188	205	1305.07 51.381	1300.75 51.211
62	394.70 15.540	390.39 15.370	98	623.89 24.562	619.57 24.392	134	853.07 33.585	848.75 33.415	170	1082.25 42.608	1077.94 42.438	206	1311.44 51.631	1307.12 51.461
63	401.07 15.790	396.75 15.620	99	630.25 24.813	625.94 24.643	135	859.44 33.836	885.12 33.666	171	1088.62 42.859	1084.30 42.689	207	1317.80 51.882	1313.48 51.712
64	407.44 16.041	403.12 15.871	100	636.62 25.064	632.30 24.894	136	865.80 34.087	861.48 33.917	172	1094.99 43.110	1090.67 42.940	208	1324.17 52.133	1319.85 51.963
65	413.80 16.291	409.48 16.121	101	642.99 25.314	638.67 25.144	137	872.17 34.337	867.85 34.167	173	1101.35 43.350	1097.03 43.190	209	1330.54 52.383	1326.22 52.213
66	420.17 16.542	415.85 16.372	102	649.35 25.565	645.03 25.395	138	878.54 34.588	874.22 34.418	174	1107.72 43.611	1103.40 43.441	210	1336.90 52.634	1332.58 52.464
67	426.54 16.793	422.22 16.623	103	655.72 25.816	651.40 25.646	139	884.90 34.839	880.58 34.669	175	1114.08 43.862	1109.77 43.692	211	1343.27 52.885	1338.95 52.715
68	432.90 17.043	428.58 16.873	104	662.08 26.066	657.77 25.896	140	891.27 35.089	886.95 34.919	176	1120.45 44.112	1116.13 43.942	212	1349.63 53.135	1345.32 52.965
69	439.27 17.299	434.95 17.124	105	668.45 26.317	664.13 26.147	141	897.63 35.340	893.32 35.170	177	1126.82 44.363	1122.50 44.193	213	1356.00 53.386	1351.68 53.216

See Page 116 for sprocket O.D. tolerances.



ENGINEERING DATA

NOTE: This engineering section provides general engineering information for synchronous belts and sprockets (or pulleys) which are useful in general drive design work. Where we refer to sprockets (for PowerGrip GT2 belts), you can substitute pulleys for PowerGrip Timing Belts. If you need additional information, contact Gates Power Transmission Product Application.

Section I

Application Design Considerations

When designing synchronous drives, there are several special circumstances that may require additional consideration:

1. Gear Motors/ Speed Reducer Drives
2. Electric Motor Frame Dimensions
3. Minimum Sprocket Diameter Recommendations for Electric Motors
4. High-Driven Inertia
5. Air Moving Drives
6. Linear Motion Drives
7. High Performance Applications
8. Belt Drive Registration
9. Belt Drive Noise
10. Use of Flanged Sprockets
11. Fixed (Nonadjustable) Center Distance
12. Use of Idlers
13. Minimum Belt Wrap and Tooth Engagement
14. Adverse Operating Environments

Each of these circumstances and special considerations are reviewed below.

1. Gear Motors/ Speed Reducer Drives

When designing a belt drive system to transfer power from the output shaft of a speed reducer to the final driven shaft, the designer must make certain that the belt drive does not exert shaft loads greater than the speed reducing device is rated to carry. Failure to do so can result in premature shaft/ bearing failures whether the belt drive has been designed with the appropriate power capacity or not.

This concept is similar to the National Electric Motor Association (NEMA) establishing minimum acceptable sprocket diameters for each of their standardized motor frames. Abiding by these minimum recommended diameters, when designing a belt drive system, prevents the motor bearings from failing prematurely due to excessive shaft loads exerted by the belt drive.

Overhung load is generally defined as a force exerted by a belt or chain drive, that is perpendicular to a speed reducer shaft, and applied beyond its outermost bearing. Calculated overhung load values are intended to serve as an indication of how heavily loaded the shaft and outermost bearing of a speed reducer actually is.

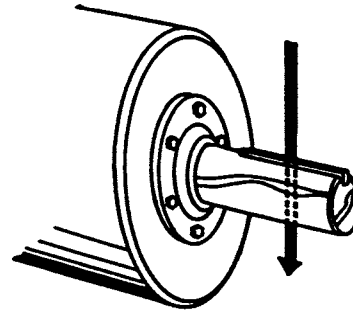

Figure 3 - Overhung Load

Overhung load calculations are generally assumed to apply to the slower output shaft of a speed reducer. It is important to note that these calculations apply to higher speed input shafts as well.

Most speed reducer manufacturers publish allowable overhung load values for every model in their product line. This value represents the maximum load that the shaft and bearings can support without negatively impacting the durability of the speed reducer. When the actual overhung load exceeds the published allowable value, premature shaft or bearing failure may occur. In extreme cases, catastrophic failures can occur.

A general formula used to calculate overhung load (OHL) is as follows:

$$OHL = \frac{126,000 \times HP \times K_{LCF} \times K_{SF} \times K_{LLF}}{PD \times RPM}$$

Where: HP = Actual horsepower being transmitted at the gear motor/reducer output shaft with no service factor applied

K_{LCF} = Overhung load connection factor (1.3 for all synchronous belt drives)

K_{SF} = Service factor for the speed reducer (available from the manufacturer)

K_{LLF} = Load location factor for the speed reducer (available from the manufacturer)

PD = Pitch diameter of the speed reducer output shaft sprocket

RPM = RPM of the speed reducer output shaft

Speed reducer manufacturers each publish their own specific formula and constants to calculate overhung load. They also publish specific overhung load ratings for each speed reducer product that they produce. It is very important to use the correct overhung load calculation procedure in conjunction with the manufacturer's accompanying overhung load rating.

If the calculated overhung load for a particular belt drive system does exceed the speed reducer manufacturer's maximum recommended value, consider altering the belt drive design. In order to reduce the calculated overhung load, consider:

- Increasing sprocket diameters
- Reducing belt width
- Mounting the sprocket closer to the speed reducer outboard bearing

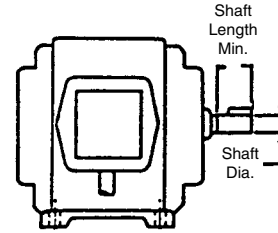

Increasing the sprocket diameter not only reduces calculated overhung load, it also potentially reduces the required belt width. Reducing the belt width and mounting the sprocket as close as possible to the outermost bearing of the speed reducer both move the center of the belt load closer to the speed reducer. This also reduces the calculated overhung load. Alterations to the belt drive design should be made until the calculated overhung load is within the speed reducer manufacturer's recommendations.

2. Electric Motor Frame Dimensions

Motor dimensions can be important considerations depending on the application and its requirements. If motor shaft length, motor shaft diameter, or clearance issues are a concern, refer to the motor dimension table on this page. The table lists common general purpose electric motors by frame size.

Motor Frame Dimensions

Frame Size	Shaft Dia. (in)	Shaft Length Min. (in)	Key (in)
48 56	1/2 5/8	— —	3/64 Flat 3/16 x 3/16 x 1-3/8
143T 145T	7/8 7/8	2 2	3/16 x 3/16 x 1-3/8 3/16 x 3/16 x 1-3/8
182 182T 184 184T	7/8 1-1/8 7/8 1-1/8	2 2-1/2 2 2-1/2	3/16 x 3/16 x 1-3/8 1/4 x 1/4 x 1-3/4 3/16 x 3/16 x 1-3/8 1/4 x 1/4 x 1-3/4
213 213T 215 215T	1-1/8 1-3/8 1-1/8 1-3/8	2-3/4 3-1/8 2-3/4 3-1/8	1/4 x 1/4 x 2 5/16 x 5/16 x 2-3/8 1/4 x 1/4 x 2 5/16 x 5/16 x 2-3/8
254U 254T 256U 256T	1-3/8 1-5/8 1-3/8 1-5/8	3-1/2 3-3/4 3-1/2 3-3/4	5/16 x 5/16 x 2-3/4 3/8 x 3/8 x 2-7/8 5/16 x 5/16 x 3-3/4 3/8 x 3/8 x 2-7/8
284U 284T 284TS 286U 286T 286TS	1-5/8 1-7/8 1-5/8 1-5/8 1-7/8 1-5/8	4-5/8 4-3/8 3 4-5/8 4-3/8 3	3/8 x 3/8 x 3-3/4 1/2 x 1/2 x 3-1/4 3/8 x 3/8 x 1-7/8 3/8 x 3/8 x 3-3/4 1/2 x 1/2 x 3-1/4 3/8 x 3/8 x 1-7/8
324U 324T 324TS 326U 326T 326TS	1-7/8 2-1/8 1-7/8 1-7/8 2-1/8 1-7/8	5-3/8 5 3-1/2 5-3/8 5 3-1/2	1/2 x 1/2 x 4-1/4 1/2 x 1/2 x 3-7/8 1/2 x 1/2 x 2 1/2 x 1/2 x 4-1/4 1/2 x 1/2 x 3-7/8 1/2 x 1/2 x 2
364U 364US 364T 364TS 365U 365US 365T 365TS	2-1/8 1-7/8 2-3/8 1-7/8 2-1/8 1-7/8 2-3/8 1-7/8	6-1/8 3-1/2 5-5/8 3-1/2 6-1/8 3-1/2 5-5/8 3-1/2	1/2 x 1/2 x 5 1/2 x 1/2 x 2 5/8 x 5/8 x 4-1/4 1/2 x 1/2 x 2 1/2 x 1/2 x 5 1/2 x 1/2 x 2 5/8 x 5/8 x 4-1/4 1/2 x 1/2 x 2
404U 404US 404T 404TS 405U 405US 405T 405TS	2-3/8 2-1/8 2-7/8 2-1/8 2-3/8 2-1/8 2-7/8 2-1/8	6-7/8 4 7 4 6-7/8 4 7 4	5/8 x 5/8 x 5-1/2 1/2 x 4 x 2-3/4 3/4 x 3/4 x 5-5/8 1/2 x 1/2 x 2-3/4 5/8 x 5/8 x 5-1/2 1/2 x 1/2 x 2-3/4 3/4 x 3/4 x 5-5/8 1/2 x 1/2 x 2-3/4
444U 444US 444T 444TS 445U 445US 445T 445TS 447T 447TS 449T 449TS	2-7/8 2-1/8 3-3/8 2-3/8 2-7/8 2-1/8 3-3/8 2-3/8 3-3/8 2-3/8 3-3/8 2-3/8	8-3/8 4 8-1/4 4-1/2 8-3/8 4 8-1/4 4-1/2 8-1/4 4-1/2 8-1/4 4-1/2	3/4 x 3/4 x 7 1/2 x 1/2 x 2-3/4 7/8 x 7/8 x 6-7/8 5/8 x 5/8 x 3 3/4 x 3/4 x 7 1/2 x 1/2 x 2-3/4 7/8 x 7/8 x 6-7/8 5/8 x 5/8 x 3 7/8 x 7/8 x 6-7/8 5/8 x 5/8 x 3 7/8 x 7/8 x 6-7/8 5/8 x 5/8 x 3

3. Minimum Sprocket Diameter Recommendations for Electric Motors

Minimum Recommended Sprocket / Sheave Diameters

NEMA (The National Electric Manufacturers Association) publishes recommendations for the minimum diameter of sprockets and sheaves to be used on General Purpose Electric Motors. The purpose of these recommendations is to prevent the use of excessively small sprockets or sheaves. This can result in motor shaft or bearing damage since belt pull increases as the diameter is reduced.

Table data has been compiled from NEMA Standard MG-1-14-42; 11/78, MG-1-14-43; 1/68, and a composite of electric motor manufacturers data. Values are generally conservative, and specific motors may permit the use of a smaller sprocket or sheave. Consult the motor manufacturer.

Motor Frames and Minimum Diameters for 60 Cycle Electric Motors

Motor Frame Code	Shaft Dia. (in)	Horsepower at Synchronous Speed (rpm)				Synchronous Belts
		3600 (3450)	1800 (1750)	1200 (1160)	900 (870)	Min. Pitch Dia. (in)
143T 145T	0.875 0.875	1-1/2 2—3	1 1-1/2—2	3/4 1	1/2 3/4	2.0 2.2
182T 182T	1.125 1.125	3 5	3 —	1-1/2 —	1 —	2.2 2.4
184T 184T 184T	1.125 1.125 1.125	— 5 7-1/2	— — 5	2 — —	1-1/2 — —	2.2 2.2 2.7
213T	1.375	7-1/2—10	7-1/2	3	2	2.7
215T 215T	1.375 1.375	10 15	— 10	5 —	3 —	2.7 3.4
254T 254T	1.625 1.625	15 20	— 15	7-1/2 —	5 —	3.4 4.0
256T 256T	1.625 1.625	20—25 —	— 20	10 —	7-1/2 —	4.0 4.0
284T 284T	1.875 1.875	— —	— 25	15 —	10 —	4.0 4.0
286T	1.875	—	30	20	15	4.7
324T	2.125	—	40	25	20	5.4
236T	2.125	—	50	30	25	6.1
364T 364T	2.375 2.375	— —	— 60	40 —	30 —	6.1 6.7
365T 365T	2.375 2.375	— —	— 75	50 —	40 —	7.4 7.7
404T 404T 404T	2.875 2.875 2.875	— — —	— — 100	60 — —	— 50 —	7.2 7.6 7.7
405T 405T 405T	2.875 2.875 2.875	— — —	— 100 125	75 — —	60 — —	9.0 7.7 9.5
444T 444T 444T 444T	3.375 3.375 3.375 3.375	— — — —	— — 125 150	100 — — —	— 75 — —	9.0 8.6 9.5 9.5
445T 445T 445T 445T	3.375 3.375 3.375 3.375	— — — —	— — 150 200	125 — — —	— 100 — —	10.8 10.8 9.5 11.9

4. High-Driven Inertia

Many drives, such as piston compressors, punch presses and crushers, depend on the drive pulley acting as a flywheel. This flywheel effect, or WR^2 is used to help moderate or smooth out fluctuations in driven load and speed. Failure to compensate for this during a redesign can result in premature damage to the prime mover or early belt failures. This can be a consideration when replacing older belt drives with new, higher capacity belts.

When replacing large pulleys or sheaves with sprockets, be careful not to remove a designed-in flywheel effect. Ask questions of the user to make sure there is not a concern for a high WR^2 . If there is a concern, you may have to use a wider sprocket, a larger diameter, or a special made-to-order sprocket designed with added weight and WR^2 .

Drives which have a high drive inertia and are subjected to high acceleration or emergency stop conditions require additional design expertise. Contact Gates Power Transmission Product Application for further engineering assistance.

5. Air Moving Drives

HVAC Equipment Inspection

Many air handling drives have structures that are not particularly rigid, which can create belt tension and drive alignment problems resulting in unusual and premature belt wear. Synchronous belts are sensitive to fluctuations in center distance that can be caused by inadequate bracketry. Under start up conditions, an AC motor can be required to provide 150% to 200% of its rated capacity. Synchronous belts cannot slip, and must transmit the higher start up torque. Under these conditions, the drive center distance may collapse if the structure is not sufficiently rigid.

With the drive shut off and safely locked out, a simple method to use when inspecting potential drive conversions is to grab the two belt spans and push them together while observing the motor. If any significant relative change in center distance or motor position is noticed, the drive's structural strength is most likely insufficient for a simple conversion. The structure would need to be reinforced to obtain optimum performance from a synchronous belt drive. The best conversion candidates have motors that are mounted solidly on support bracketry that is part of the fan's structural system. When possible, select synchronous drives with diameters similar to existing V-belt sheave diameters. This will maintain similar belt pulls and loads on the shafts and structure.

Air Handling Unit Start-Up Characteristics

Full Load Start Up

Start up loads can be a concern when evaluating potential drives for conversion to synchronous belts. Synchronous belts will transmit all of the start up torque, where V-belts may slip if the load is excessive. Due to the inertia of the fan, start up loads can potentially be 150% to 200% of the normal operating load. It is important that the start up load be considered by selecting appropriate service factors when designing a belt drive system.

Controlled Start Up

An air handling drive with soft start or variable frequency controller (AC Inverter) is ideal for conversion to synchronous belts. The fan will be ramped up to speed slowly, with a corresponding increase in load as the speed increases. Structural flexing is typically not a concern when designing synchronous belt drives on systems using soft starts or variable frequency controllers.

Fan Speed

The volume of air being transmitted and the required horsepower are both sensitive to changes in the driveN fan speed. If designing a synchronous belt drive for energy savings, it is important that the synchronous belt drive be designed to operate at the proper driveN fan speed. All conversions from existing V-belt drives should have the synchronous belt drive speed ratio based on a measured driveN shaft RPM, and not calculated from the theoretical V-belt speed ratio. This measurement can be made by either using a mechanical contact tachometer or a strobe tachometer.

The horsepower requirement for fans varies with the cube of the fan speed. A small change in the fan speed makes a much larger difference in the actual horsepower and energy required.

$$HP_1/HP_2 = (RPM_1/RPM_2)^3$$

Where: HP_1 = Initial Horsepower
 HP_2 = New Horsepower @ New Fan RPM
 RPM_1 = Initial Fan RPM
 RPM_2 = New Fan RPM

6. Linear Motion Drives

In linear motion drives, such as a rack and pinion application, the belt is not transmitting a load in the conventional rotational manner. The two cut ends of the belt are connected to clamping fixtures and the belt travels back and forth a specified distance while rotating over a sprocket. Because of these characteristics, the drive design process will typically not follow standard catalog design procedures.

The designer will most likely have available a maximum belt load or pull which will need to be related to the belt's allowable working tension. Reasonably sized sprocket diameters are still required to prevent excessive stress fatigue in the belt. In these applications, the designer may either use endless belts and cut them, or use standard long length belting when available. Design information and belt clamping recommendations are included on pages 85 through 94, PowerGrip Long Length Belting. Gates Power Transmission Product Application may also be consulted for additional design assistance.

7. High Performance Applications

For special high performance applications, such as motorcycles or race car and boat supercharger drives, the design loads will typically exceed published data. Because of the extremely high loads and speeds (as much as 500 HP and belt speeds exceeding 10,000 fpm), it is necessary for the designer to contact Gates Power Transmission Product Application for additional assistance.

Although special considerations may be involved, it is important to remember that reasonable drive recommendations can be provided to the designer in most cases.

8. Belt Drive Registration

The three primary factors contributing to belt drive registration (or positioning) errors are belt elongation, backlash, and tooth deflection. When evaluating the potential registration capabilities of a synchronous belt drive, the system must first be determined to be either static or dynamic in terms of its registration function and requirements.

Static Registration: A static registration system moves from its initial static position to a secondary static position. During the process the designer is concerned only with how accurately and consistently the drive arrives at its secondary position. Potential registration errors that occur during transport are not considered. Therefore, the primary factor contributing to registration error in a static registration system is backlash. The effects of belt elongation and tooth deflection do not have any influence on the registration accuracy of this type of system.

Dynamic Registration: A dynamic registration system is required to perform a registering function while in motion with torque loads varying as the system operates. In this case, the designer is concerned with the rotational position of the drive sprockets with respect to each other at every point in time. Therefore, belt elongation, backlash, and tooth deflection will all contribute to registrational inaccuracies.

Further discussion about each of the factors contributing to registration error is as follows:

Belt Elongation: Belt elongation, or stretch, occurs naturally when a belt is placed under tension. The total tension exerted within a belt results from installation as well as working loads. The amount of belt elongation is a function of the belt tensile modulus, which is influenced by the type of tensile cord and the belt construction. The standard tensile cord used in rubber synchronous belts is fiberglass. Fiberglass has a high tensile modulus, is dimensionally stable, and has excellent flex-fatigue characteristics. If a higher tensile modulus is needed in a rubber synchronous belt, aramid tensile cords can be considered, although they are generally used to provide resistance to harsh shock and impulse loads. Aramid tensile cords used in rubber synchronous belts generally have only a marginally higher tensile modulus in comparison to fiberglass. When needed, belt tensile modulus data is available from Gates Power Transmission Product Application.

Backlash: Backlash in a synchronous belt drive results from clearance between the belt teeth and the sprocket grooves. This clearance is needed to allow the belt teeth to enter and exit the grooves smoothly with a minimum of interference. The amount of clearance necessary depends upon the belt tooth profile. PowerGrip® Timing Belt Drives are known for having relatively little backlash. PowerGrip® HTD® Drives have improved torque carrying capability and resist ratcheting, but have a significant amount of backlash. PowerGrip® GT2 Drives have considerably improved torque carrying capability, and backlash characteristics in between that of PowerGrip HTD and PowerGrip Timing Drives. In special cases, alterations can be made to drive systems to



further decrease backlash. These alterations often result in increased belt wear, increased drive noise and shorter drive life. Contact Gates Power Transmission Product Application for additional information.

Tooth Deflection: Tooth deformation in a synchronous belt drive occurs as a torque load is applied to the system, and individual belt teeth are loaded. The amount of belt tooth deformation depends upon the amount of torque loading, sprocket size, installation tension and belt type. Of the three primary contributors to registration error, tooth deflection is the most difficult to quantify. Experimentation with a prototype drive system is the best means of obtaining realistic estimations of belt tooth deflection.

Additional guidelines that may be useful in designing registration critical drive systems are as follows:

- Design with large sprockets with more teeth in mesh.
- Keep belts tight, and control tension closely.
- Design frame/shafting to be rigid under load.
- Use high quality machined sprockets to minimize radial run out and lateral wobble.

9. Belt Drive Noise

Field experience on actual applications verifies that some positive belt drives can produce some noise. The noise levels produced are typically greater than V-belts, and are associated with tooth meshing characteristics. For the most part, this noise is low level and will not exceed the level of noise produced by the equipment it is used on or the surrounding environment of the equipment. Laboratory studies (confirmed by field studies), using highly instrumented equipment, show a high probability for significant noise generation at speeds greater than 3,500 feet per minute and belt widths in excess of 85mm.

Many times a belt drive system, when operating under load, is not the primary cause for noise. Undersized, poorly lubricated, worn or misaligned bearings can cause significant noise levels. Rotating parts of a total system can create air disturbances, thus generating noise. A weak structural design could flex under the load and cause misalignment and affect components in the drive system, thereby creating noise. Consideration should also be given to assuring that the total system has not been designed to act as an echo chamber, thus amplifying an otherwise insignificant noise.

It becomes obvious there are many sources for noise in most applications. The study and understanding of noise analysis is a complex and controversial issue. It should be apparent to the designer that noise problems require very careful and thorough examinations. If belt drive noise is a problem, contact Gates Power Transmission Product Application for further assistance.

10. Use of Flanged Sprockets

Guide flanges are needed in order to keep the belt on the sprocket. Due to tracking characteristics, even on the best aligned drives, belts will ride off the edge of the sprockets. Flanges will prevent this belt ride-off.

On all drives using stock or made-to-order sprockets, the following conditions should be considered when selecting flanged sprockets:

1. On all two-sprocket drives, the minimum flanging requirements are two flanges on one sprocket or one flange on each sprocket on opposite sides.
2. On drives where the center distance is more than eight times the diameter of the small sprocket, both sprockets should be flanged on both sides. (See Engineering Section II-10, Drive Alignment on page 141 and Engineering Section II-11, Belt Installation on page 142.)
3. On vertical shaft drives, one sprocket should be flanged on both sides, and all the other sprockets in the system should be flanged on the bottom side only.
4. On drives with more than two sprockets, the minimum flanging requirements are two flanges on every other sprocket or one flange on every sprocket—on alternating sides around the system.

On made-to-order sprockets, flanges must be securely fastened, such as using mechanical fasteners, welding, shrink-fit or other equivalent methods.

11. Fixed (Nonadjustable) Center Distance

Designers sometimes attempt to design synchronous belt drive systems without any means of belt adjustment or take up. This type of system is called a Fixed Center Drive. While this approach is often viewed as being economical, and is simple for assemblers, it often results in troublesome reliability and performance problems in the long run.

The primary pitfall in a fixed center design approach is failure to consider the affects of system tolerance accumulation. Belts and sprockets are manufactured with industry accepted production tolerances. There are limits to the accuracy that the center distance can be maintained on a production basis as well. The potential effects of this tolerance accumulation is as follows:

Low Tension:

Long Belt with Small Sprockets on a Short Center Distance

High Tension:

Short Belt with Large Sprockets on a Long Center Distance

Belt tension in these two cases can vary by a factor of 3 or more with a standard fiberglass tensile cord, and even more with an aramid tensile cord. This potential variation is great enough to overload bearings and shafting, as well as the belts themselves. The probability of these extremes occurring is a matter of statistics, but however remote the chances seem, they will occur in a production setting. In power transmission drives, the appearance of either extreme is very likely to impact drive system performance in a negative manner.

The most detrimental aspect of fixed center drives is generally the potentially high tension condition. This condition can be avoided by adjusting the design center distance. A common approach in these designs is to reduce the center distance from the exact calculated value by some small fraction. This results in a drive system that is inherently loose, but one that has much less probability of yielding excessively high shaft loads. **NOTE:** This approach should not be used for power transmission drives since the potentially loose operating conditions could result in accelerated wear and belt ratcheting, even under nominal loading.

There are times when fixed center drive designs can't be avoided. In these cases, the following recommendations will maximize the probability of success.

1. Do not use a fixed center design for power transmission drives. Consider using a fixed center design only for lightly loaded or motion transfer applications.
2. Do not use a fixed center design for drives requiring high motion quality or registration precision.
3. When considering a fixed center design, the center distance must be held as accurately as possible, typically within 0.002"—0.003" (0.05mm—0.08mm). This accuracy often requires the use of stamped steel framework. Molding processes do not generally have the capability of maintaining the necessary accuracy.
4. Sprockets for fixed center systems should be produced with a machining process for accuracy. Molding and sintering processes are generally not capable of holding the finished O.D. sufficiently accurate for these systems.
5. The performance capabilities of the drive system should be verified by testing belts produced over their full length tolerance range on drive systems representing the full potential center-distance variation. Contact Gates Power Transmission Product Application for further details.
6. Contact Gates Power Transmission Product Application for design center distance recommendations, and to review the application.

12. Use of Idlers

Use of idlers should be restricted to those cases in which they are functionally necessary. Idlers are often used as a means of applying tension when the center distance is not adjustable.

Idlers should be located on the slack side span of the belt drive. For inside idlers, grooved sprockets are recommended up to 40 grooves. On larger diameters, flat uncrowned idlers may be used. In some cases, such as high capacity drives utilizing large sprockets, idlers as large as the smallest loaded sprocket in the system may be more appropriate.

Outside or backside idlers should be flat and uncrowned; flanges may or may not be necessary. Diameters should not be smaller than 1.3 times the smallest recommended inside sprocket size.

Idler arc of contact should be held to a minimum. All idlers should be rigidly mounted in place to minimize movement or deflection during drive startup and operation.

In most cases, use of spring-loaded idlers is not recommended on positive belt applications. This stems from the fact that a synchronous belt can generate sufficient tension to overcome any reasonable force imposed by a spring-loaded idler (See Engineering Section II-14, Self-Generated Tension on page 143). The belt may ratchet in this situation because the idler has not maintained sufficient belt tension on the slack side span. Any spring force sufficient to resist being overcome by belt span tensions may be excessive and could significantly reduce belt life. Exceptions include lightly loaded applications.

13. Minimum Belt Wrap and Tooth Engagement

Horsepower ratings listed in this catalog are based on a minimum of six teeth in mesh between the belt and the sprocket. The ratings must be corrected for excessive tooth loading if there are less than six teeth in mesh. For non-stock drives not listed in the Drive Selection Tables, the teeth in mesh may be calculated by using this formula:

$$\text{Teeth in Mesh} = \left[0.5 - \left(\frac{D - d}{6C} \right) \right] N_s$$

Where: D = pitch diameter, large sprocket, inches
d = pitch diameter, small sprocket, inches
C = center distance between shafts, inches
N_s = number of grooves in small sprocket

In cases where fewer than six teeth are in full contact, 20% of the horsepower rating must be subtracted for each tooth less than six not in full contact. After computing the teeth in mesh, the belt rating should be multiplied by the appropriate K_{tm} factor shown in the following table.

Teeth In Mesh Correction Factor

Teeth in Mesh	Factor K _{tm}
6 or more	1.00
5	0.80
4	0.60
3	0.40
2	0.20

In addition to the number of teeth in mesh, some drives with more than two shafts may have a greater potential for the belts to ratchet where loaded sprockets have 6 teeth in mesh, but a small arc of contact. In order to minimize this condition, each loaded sprocket in the drive system should have an arc of contact or belt wrap angle of at least 60 degrees. Non-loaded idler sprockets do not have tooth meshing or wrap angle requirements.



14. Adverse Operating Environments

Debris

Be very careful when using synchronous drives in high debris environments. Debris can be more damaging to the positive belt drive than a V-belt drive, which has a tendency to remove debris from the sheave grooves through drive operation. Entrapment of debris in synchronous drives is a major concern. Debris can be packed into sprocket grooves causing improper belt tooth engagement, reducing belt life and accelerating belt and sprocket wear. Care must be taken to provide adequate shielding to drives in environments where debris is likely. Completely enclosing a synchronous belt drive may be acceptable. Since synchronous belts generate minimal heat during drive operation, air circulation is not critical except where extremely high temperatures already are present. Depending on the type and abrasive characteristics of the debris, excessive wear can be generated on both belt and sprockets.

Temperature

Belt performance is generally unaffected in ambient temperature environments between -30° and 185°F (-34° and 85°C). Temperature extremes beyond these limits should be reviewed by Gates Power Transmission Product Application.

Chemical Resistance

Based on lab and field testing, PowerGrip belts provide excellent resistance to most chemicals. Actual performance characteristics will be determined by the degree of concentration of the chemical, the time of exposure and the type of exposure (drip, splash, immersion, etc.). In addition to possible belt degradation, these chemicals can act as a lubricant in the drive system. As with any positive belt drive, PowerGrip drives which run where excessive lubrication is present have an increased tendency to ratchet (See Engineering Section II-14, Self Generated Tension on page 143). Special attention should be given to assure that recommended tension is maintained (See Engineering Section II-8, Belt Installation Tension on page 139).

High Humidity

Many industrial applications face the problems of rusting parts. This is equally true of sprockets when used in very wet or humid environments, such as seen with air moving drives on cooling towers or wood kilns. The constant effects of the wet air surrounding the belt drive can cause excessive rust, which in the most severe cases may lead to premature wear.

In these instances the designer may elect to use special stainless steel sprockets or a more economical choice such as nickel coating. A 0.001" thick coating of electroless nickel can, in many instances, dramatically slow down the effects of rusting.

Section II

Engineering Design Considerations

All synchronous belt drives require proper installation procedures for optimum performance. In addition, topics such as tooth profile advantages, sprocket rim speed limitations, efficiency, and tolerances are common to all Gates synchronous belt drives.

1. Belt Storage and Handling
2. Center Distance and Belt Length
3. Tooth Profiles
4. Static Conductivity
5. Sprocket Diameter - Speed
6. Efficiency
7. Belt Tolerances
8. Belt Installation Tension
9. Center Distance Allowances for Installation and Tensioning
10. Drive Alignment
11. Belt Installation
12. Belt Pull Calculations
13. Bearing/Shaft Load Calculations
14. Self-Generated Tension

Each of these circumstances and special considerations are reviewed below.

1. Belt Storage and Handling

Synchronous belts should be protected from moisture, temperature extremes, direct sunlight and high ozone environments. Each belt should be stored in its original package, avoiding any sharp bends or crimping which will cause damage. When properly stored, Gates synchronous belts should easily meet the criteria covered in RMA Bulletin IP-3-4 (eight years' storage with no reduced performance).

2. Center Distance and Belt Length

The approximate relationship between a center distance and belt pitch length is given by the following formula:

Formula 1

$$L_p = 2C + 1.57(D + d) + \frac{(D - d)^2}{4C}$$

Where: L_p = belt pitch length, inches
 D = diameter of large sprocket, inches
 d = diameter of small sprocket, inches
 C = center distance, inches

A more precise formula is given below:

Formula 2

$$L_p = 2C \cos \varphi + \frac{\pi (D + d)}{2} + \frac{\pi \varphi (D - d)}{180}$$

Where: L_p = belt pitch length, inches
 C = center distance, inches
 D = pitch diameter of large sprocket, inches
 d = pitch diameter of small sprocket, inches

$$\varphi = \sin^{-1} \left(\frac{D - d}{2C} \right) \text{ degrees}$$

The approximate center distance can be found by this formula:

Formula 3

$$C = \frac{K + \sqrt{K^2 - 32 (D - d)^2}}{16}$$

Where: $K = 4L_p - 6.28 (D + d)$

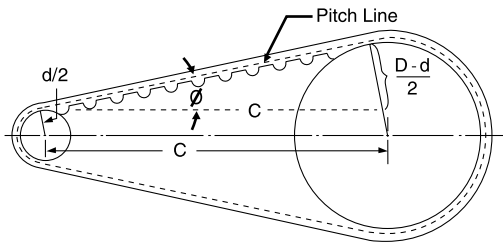

The exact center distance can be calculated using an iterative process between the center distance (Formula 3) and belt length (Formula 2) equations. The exact center distance has been found when the two equations converge. The pitch length increment of a synchronous belt is equal to a multiple of the belt pitch.

3. Tooth Profiles

Conventional trapezoidal belts (MXL, XL, etc.) were the earliest developments of positive drive belts. In more recent years, new curvilinear profiles have entered the market. The most predominant of these profiles is the HTD® system (5mm, 8mm, etc.). While these curvilinear profiles provide many advantages, they also can provide significant disadvantages.

With the development of the new Gates GT® tooth profile, the combined advantages of the various curvilinear profiles have now been optimized. Characteristics such as ratcheting resistance, improved load/life and noise reduction were prime factors in the design of the Gates GT® profile. Additionally, it allowed optimization in incorporating premium materials into its superior construction.

The GT® tooth profile is based on the tractrix mathematical function. Engineering handbooks describe this function as a “frictionless” system. This early development by Schiele is described as an involute form of a catenary. With this system, the belt and sprocket teeth move substantially tangentially during entry and exit, thus improving significantly the belts’ performance characteristics. This is illustrated in Fig. 4.

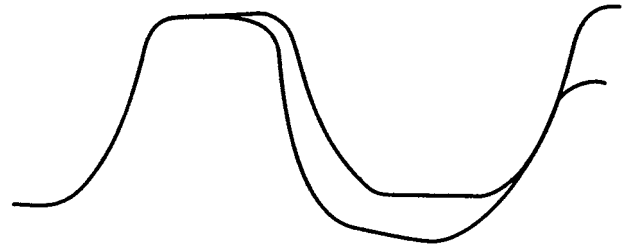

Figure 4

4. Static Conductivity

All belts, whether made from rubber or urethane, naturally build up an electric charge while in operation. While the likelihood that an electrical discharge from a belt could actually cause a detonation continues to be a point of speculation, lower humidity levels around 15% are known to result in significantly stronger electrical charges than higher humidity levels around 60% or more. Thus, greater precautions should be taken for belt drive systems operating in low humidity, or dry, environments.

Power transmission belts produced in a conductive construction have traditionally been considered to be relatively safe for explosive environments. Conductive belts continuously dissipate their electrical charge into the ferrous sprockets or sheaves on which they operate. The test procedure described in RMA Bulletin IP-3-3/1995 provides a measurable standard of belt conductivity to ensure that electrical charges from power transmission belts are safely dissipated into the belt drive hardware. It is important to note that this test procedure applies only to new belts.

PowerGrip belts do not meet the static conductivity requirements specified in RMA Bulletin IP-3-3/1995. Though PowerGrip belts can be produced in a conductive construction, it is important to understand that belt conductivity properties are known to decay over time with belt usage. In addition, power transmission belts that do not meet the RMA IP-3-3 standard are widely available. A conductive power transmission belt used in an explosive environment could inadvertently be replaced with an unsafe belt, creating a potential safety hazard.

The user must ensure that belt drives operating in potentially hazardous or explosive environments are designed and installed in accordance with existing building codes, OSHA requirements, and/or recognized safety-related organizations.

5. Sprocket Diameter—Speed



Drives shaded in the Belt Width Selection Tables on pages 44 through 51, pages 56 through 58, and pages 75 through 84 use sprocket diameters that may reduce belt life. The amount of reduction will depend on speed—the higher the speed, the greater the reduction. The drives are included for use where speed ratio or space requirements must be met. Blanks in the lower right-hand portions of the Belt Width Selection Tables occur because sprocket rim speed exceeds 6,500 feet per minute. Centrifugal forces developed beyond this speed may prohibit the use of stock gray cast iron sprockets. For rim speeds above 6,500 feet per minute, contact Gates Power Transmission Product Application for other alternatives.

Sprockets Recommended

For maximum performance, we recommend using Gates PowerGrip belts only with Gates PowerGrip® Sprockets

6. Efficiency

When properly designed and applied, PowerGrip belt drive efficiency will be as high as 98%. This high efficiency is primarily due to the positive, no slip characteristic of synchronous belts. Since the belt has a thin profile, it flexes easily, thus resulting in low hysteresis losses as evidenced by low heat buildup in the belt.

Gates synchronous belts are uniquely constructed because they use high performance materials. Optimization of these high-technology features provide maximum performance and efficiency.

Synchronous belt drive efficiency can be simply defined as shown in the following equation:

$$\text{Efficiency, percent} = \frac{\text{DN RPM} \times \text{DN Torque}}{\text{DR RPM} \times \text{DR Torque}} \times 100$$

When examining the loss of energy, it is necessary to consider belt losses in terms of shaft torque and shaft speed. Torque losses result from bending stress and friction. Chain drives running unlubricated may generate significant

heat build up due to increased friction in the roller joints. Even properly lubricated chains running at higher speeds tend to throw off the oil due to centrifugal forces, making it difficult to maintain proper lubrication at the load bearing surfaces. Consequently, chain drives are typically only 92-98% efficient.

Speed losses result from belt slip and creep. Unlike V-belts, slip is not a factor with synchronous belts. Well maintained V-belt drives are typically in the range of 95-98% efficient. However, on a poorly designed or maintained drive, the efficiency may drop as much as 5% or more. If proper maintenance cannot be scheduled for a V-belt drive or it is located in an inaccessible area, a positive belt drive system should be considered.

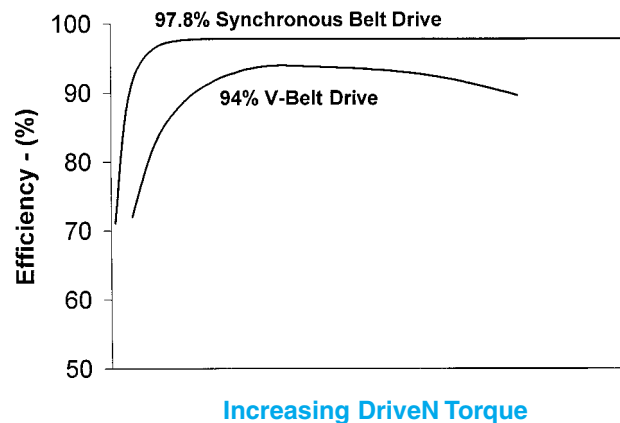

The belt drive is only part of the total system. Motors should be properly sized for the application. They must have sufficient capacity to meet the power needs, yet over-designed motors will lead to electrical inefficiencies. DriveN machines also may have inherent inefficiencies which may contribute to overall system efficiency.

7. Belt Tolerances

These tolerances are for reference only. For fixed center drive applications and special tolerances, contact Gates Power Transmission Product Application.

Stock Belt Center Distance Tolerances			
Belt Length	(mm) (in)	Center Distance Tolerance	(mm) (in)
over 127 5	to 254 10	± 0.20 .008	
over 254 10	to 381 15	± 0.23 .009	
over 381 15	to 508 20	± 0.25 .010	
over 508 20	to 762 30	± 0.30 .012	
over 762 30	to 1016 40	± 0.33 .013	
over 1016 40	to 1270 50	± 0.38 .015	
over 1270 50	to 1524 60	± 0.41 .016	
over 1524 60	to 1778 70	± 0.43 .017	
over 1778 70	to 2032 80	± 0.46 .018	
over 2032 80	to 2286 90	± 0.49 .019	
over 2286 90	to 2540 100	± 0.52 .020	
over 2540 100	to 2794 110	± 0.54 .021	
over 2794 110	to 3048 120	± 0.56 .022	
over 3048 120	to 3302 130	± 0.58 .023	
over 3302 130	to 3556 140	± 0.60 .024	
over 3556 140	to 3810 150	± 0.63 .025	
over 3810 150	to 4064 160	± 0.66 .026	
over 4064 160	to 4318 170	± 0.69 .027	
over 4318 170	to 4572 180	± 0.72 .028	
over 4572 180		add ± .03 .001 for every 254 10 increment	

Stock Belt Width Tolerances							
Belt Width (in)	(mm)	Belt Width Tolerances					
		Belt Lengths (in)		Belt Lengths (in)		Belt Lengths (in)	
		0 to 33	838 to 1676	838 to 1676	1676 to 3300	1676 to 3300	3300 to 6600
over 0.438	11.1 to 1.500	+ .8 0.032	- .8 0.032	+ .8 0.032	- 1.2 0.047	+ .8 0.032	- 1.2 0.047
over 1.500	38.1 to 2.000	+ .8 0.032	- 1.2 0.047	+ 1.2 0.047	- 1.2 0.047	+ 1.2 0.047	- 1.6 0.063
over 2.000	50.8 to 2.500	+ 1.2 0.047	- 1.2 0.047	+ 1.2 0.047	- 1.6 0.063	+ 1.6 0.063	- 1.6 0.063
over 2.500	63.5 to 3.000	+ 1.2 0.047	- 1.6 0.063	+ 1.6 0.063	- 1.6 0.063	+ 1.6 0.063	- 2.9 0.078
over 3.000	76.2 to 4.000	+ 1.6 0.063	- 1.6 0.063	+ 1.6 0.063	- 2.0 0.078	+ 2.0 0.078	- 2.0 0.078
over 4.000	101.6 to 7.000	+ 2.4 0.094	- 2.4 0.094	+ 2.4 0.094	- 2.8 0.109	+ 2.4 0.094	- 3.2 0.125
over 7.000	177.8 to					+ 4.8 0.188	- 6.4 0.250

8. Belt Installation Tension

Standard Belt Tensioning Procedure

When installing a Gates PowerGrip belt:

- A.** Be sure it is tensioned adequately to prevent tooth jumping (ratcheting) under the most severe load conditions which the drive will encounter during operation.
- B.** Avoid extremely high tension which can reduce belt life and possibly damage bearings, shafts and other drive components.

When you wish to use a numerical method for calculating recommended belt installation tension values, the following procedure should be used:

Measure the force (lb) required to deflect one belt span a given amount, as shown in the sketch below.

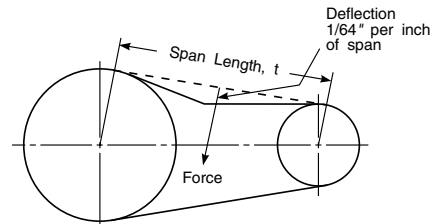

STEP 1: Calculate the required base static installation tension.

Use Formula 4 to calculate the required base static installation tension.

Formula 4

$$T_{st} = \frac{17.4DHP}{S} + mS^2, \text{ pounds}$$

Where: T_{st} = base static installation tension
 DHP = Design Horsepower
 $S = \frac{PD \times RPM}{3820}$
 m = Value from Table 3
 PD = Sprocket Pitch Diameter, inches
 RPM = Sprocket Speed

Table 3

Pitch	Belt Width	m	Y	Minimum T_{st} (lb) per span
5MR PowerGrip GT2	9mm	0.17	14.90	8.4
	15mm	0.28	24.90	14.1
	25mm	0.47	41.50	23.4
8M PowerGrip GT2 PowerGrip GT	20mm	0.58	34.18	18.5
	30mm	0.88	51.27	30.0
	50mm	1.46	85.45	52.0
	85mm	2.45	145.26	94.5
14M PowerGrip GT2 PowerGrip GT	40mm	1.78	93.04	76.5
	55mm	2.44	127.93	120.0
	85mm	3.77	197.72	205.5
	115mm	5.11	267.50	291.0
20M PowerGrip GT2	170mm	7.55	395.43	447.5
	115mm	7.24	366.98	391.5
	170mm	10.71	542.49	603.0
	230mm	14.49	733.96	834.0
	290mm	18.27	925.43	1065.0
5M PowerGrip HTD	340mm	21.42	1084.99	1257.5
	15mm	0.26	13.32	12.0
XL PowerGrip Timing	25mm	0.43	22.20	16.5
	1/4 in.	0.07	3.30	3.2
L PowerGrip Timing	3/8 in.	0.11	4.90	5.1
	1/2 in.	0.19	10.00	13.0
	3/4 in.	0.29	18.00	19.0
H PowerGrip Timing	1 in.	0.38	25.00	25.0
	3/4 in.	0.34	33.00	54.0
	1 in.	0.46	47.00	72.0
	1-1/2 in.	0.69	73.00	110.0
XH PowerGrip Timing	2 in.	0.92	100.00	140.0
	3 in.	1.40	160.00	220.0
	2 in.	2.70	200.00	210.0
	3 in.	4.00	320.00	310.0
XXH PowerGrip Timing	4 in.	5.30	460.00	410.0
	2 in.	3.50	320.00	260.0
	3 in.	5.30	510.00	390.0
	4 in.	7.00	720.00	520.0
	5 in.	8.80	930.00	650.0

Because of the high performance capabilities of PowerGrip belts, it is possible to design drives that have significantly greater load than are necessary to carry the actual design load. Consequently, Formula 4 can provide T_{st} values less than are necessary for the belt to operate properly, resulting in poor belt performance and reduced service life.

If a more appropriately sized drive cannot be designed, minimum recommended T_{st} values are provided in Table 3 to assure that the PowerGrip belts are tensioned properly when lightly loaded.

Always use the greater T_{st} value; i.e., from T_{st} Formula 4 or Table 3.

NOTE: When applying static belt tension values directly, multiply the required base static installation tension (T_{st}) calculated in Formula 4 by the following factors:

For New Belts:

Minimum Static Tension = $1.4 \times T_{st}$
 Maximum Static Tension = $1.5 \times T_{st}$

For Used Belts:

Minimum Static Tension = $1.2 \times T_{st}$
 Maximum Static Tension = $1.3 \times T_{st}$

STEP 2: Calculate the minimum and maximum recommended deflection forces.

A. Measure the span length of your drive (see sketch).

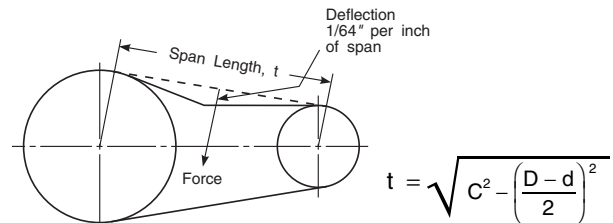

B. New belt minimum recommended force:

Formula 5

$$\text{deflection force, Min.} = \frac{1.4 T_{st} + \left(\frac{t}{L}\right) Y}{16}, \text{ lb}_f$$

C. New belt maximum recommended force:

Formula 6

$$\text{deflection force, Max.} = \frac{1.5 T_{st} + \left(\frac{t}{L}\right) Y}{16}, \text{ lb}_f$$

Where: T_{st} = Base Static installation tension, lbf
 (Formula 4 or Table 3)

t = span length, inches

L = belt pitch length, inches

Y = constant from Table 3

USED BELT NOTE: For re-installation of a used belt, a recommended tension of $1.2 T_{st}$ to $1.3 T_{st}$ value should be used in calculating the deflection forces, instead of the $1.4 T_{st}$ to $1.5 T_{st}$ shown for new belts.

STEP 3: Applying the tension.

A. At the center of the span (t) apply a force perpendicular to the span large enough to deflect the belt on the drive $\frac{1}{64}$ inch per inch of span length from its normal position. One sprocket should be free to rotate. Be sure the force is applied evenly across the entire belt width.

B. Compare this deflection force with the range of forces calculated in Step 2.

1. If it is less than the minimum recommended deflection force, the belt should be tightened.
2. If it is greater than the maximum recommended deflection force, the belt should be loosened.

9. Center Distance Allowances for Installation and Tensioning

Since fixed center drives are not recommended, center distance allowances for a Gates PowerGrip belt drive are necessary to assure that the belt can be installed without damage and then tensioned correctly. The standard installation allowance is the minimum decrease in center distance required to install a belt when flanged sprockets are removed from their shafts for belt installation. This is shown in the first column of Table 4. This table also lists the minimum increase in center distance required to assure that a belt can be properly tensioned over its normal lifetime. If a belt is to be installed over flanged sprockets without removing them, the additional center distance allowance for installation shown in the second table below must be added to the first table data.

Table 4

Center Distance Allowance For Installation and Tensioning

Length Belt (mm) (in)	Standard Installation Allowance (Flanged Sprockets Removed For Installation) (mm) (in)	Tensioning Allowance (All Drives) (mm) (in)
Up to 125 5	0.5 0.02	0.5 0.02
Over 125 to 250 5 10	0.8 0.03	0.8 0.03
Over 250 to 500 10 20	1.0 0.04	0.8 0.03
Over 500 to 1000 20 40	1.8 0.07	0.8 0.03
Over 1000 to 1780 40 70	2.8 0.10	0.8 0.04
Over 1780 to 2540 70 100	3.3 0.13	1.0 0.04
Over 2540 to 3300 100 130	4.1 0.16	1.3 0.05
Over 3300 to 4600 130 180	4.8 0.19	1.3 0.05
Over 4600 to 6900 180 270	5.6 0.22	1.3 0.05

Additional Center Distance Allowance For Installation Over Flanged Sprockets*

(Add to Installation Allowance In Table No. 4)

Pitch	One Sprocket Flanged (mm) (in)	Both Sprockets Flanged (mm) (in)
0.080" (MXL)	8.4 0.33	12.4 0.49
0.200" (XL)	11.7 0.46	18.0 0.71
0.375" (L)	16.3 0.64	21.6 0.85
0.500" (H)	16.3 0.64	24.4 0.85
5mm	13.5 0.53	19.1 0.75
8mm	21.8 0.86	33.3 1.31
14mm	31.2 1.23	50.0 1.97
20mm	47.0 1.85	77.5 3.05

* For drives that require installation of the belt over one sprocket at a time, use the value for "Both Sprockets Flanged"

10. Drive Alignment

Provision should be made for center distance adjustment, according to the two tables on this page, or to change the idler position so the belt can be slipped easily onto the drive. When installing a belt, never force it over the flange. This will cause internal damage to the belt tensile member.

Synchronous belts typically are made with high modulus tensile members which provide length stability over the belt life. Consequently, misalignment does not allow equal load distribution across the entire belt top width. In a misaligned drive, the load is being carried by only a small portion of the belt top width, resulting in uneven belt wear and premature tensile failure.

There are two types of misalignment: parallel and angular (See Fig.5). Parallel misalignment is where the driveR and driveN shafts are parallel, but the two sprockets lie in different planes. When the two shafts are not parallel, the drive is angularly misaligned.

A fleeting angle is the angle at which the belt enters and exits the sprocket, and equals the sum of the parallel and angular misalignments.

Any degree of sprocket misalignment will result in some reduction of belt life, which is not accounted for in the normal drive design procedure. Misalignment of all synchronous belt drives should not exceed 1/4° or 1/16" per foot of linear distance. Misalignment should be checked with a good straight edge tool. The tool should be applied from driveR to driveN, and then from driveN to driveR so that the total effect of parallel and angular misalignment is taken into account.

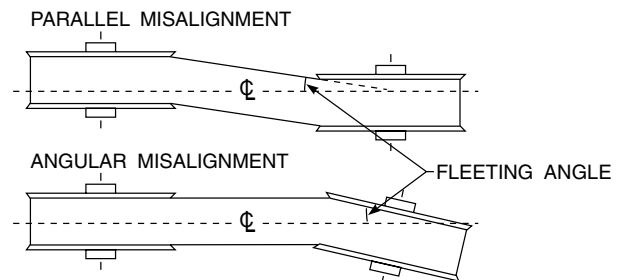

Figure 5

Drive misalignment can also cause belt tracking problems. However, light flange contact by the belt is normal and won't affect performance.

For those drives in which the center distance is greater than eight times the small sprocket diameter, belt tracking can be a problem. In these cases, the parallel position of the two sprockets may need to be adjusted until only one flange guides the belt in the system and the belt tracks fully on all sprockets. Regardless of the drive center distance, the optimum drive performance will occur with the belt lightly contacting one flange in the system. The worst case is for the belt to contact flanges on opposite sides of the system. This traps the belt between opposite flanges and can force the belt into undesirable parallel misalignment.

Improper installation of the bushing can result in the bushing / sprocket assembly being "cocked" on the shaft. This leads to angular misalignment and sprocket wobble. Be sure to follow the instructions provided with the bushings.

11. Belt Installation

During the belt installation process, it is very important the belt be fully seated in the sprocket grooves before applying final tension. Serpentine drives with multiple sprockets and drives with large sprockets are particularly vulnerable to belt tensioning problems resulting from the belt teeth being only partially engaged in the sprockets during installation. In order to prevent these problems, the belt installation tension should be evenly distributed to all belt spans by rotating the system by hand. After confirming that belt teeth are fully engaged in the sprocket grooves, belt tension should be rechecked and verified. Failure to do this may result in an undertensioned condition with the potential for belt ratcheting.

12. Belt Pull Calculations

When the machine designer requests shaft load calculations from the drive designer, the following procedure can be applied:

A. Calculate Belt Span Tensions

Belt pull is the vector sum of T_T and T_S , the tightside and slackside tensions. T_T and T_S may be calculated using the following formulas:

Formula 7

$$T_T = \frac{144,067 \text{ DHP}}{(\text{PD})(\text{RPM})}$$

Formula 8

$$T_S = \frac{18,008 \text{ DHP}}{(\text{PD})(\text{RPM})}$$

Where: DHP = Horsepower x Service Factor
 PD = Sprocket Pitch Diameter (in)
 RPM = Sprocket Speed (rev/min)

B. Solution For Both Magnitude and Direction

The vector sum of T_T and T_S can be found so that the direction of belt pull, as well as magnitude, is known. This is necessary if belt pull is to be vectorially added to sprocket weight, shaft weight, etc., to find true bearing loads. In this case, the easiest method of finding the belt pull vector is by graphical addition of T_T and T_S . If only the magnitude of belt pull is needed, numerical methods for vector additions are faster to use.

If both direction and magnitude of belt pull are required, the vector sum of T_T and T_S can be found by graphical vector addition as shown in Fig. 6. T_T and T_S vectors are drawn to a convenient scale and parallel to the tightside and slackside, respectively. Fig. 6 shows vector addition for belt pull on the motor shaft. The same procedures can be used for finding belt pull on the driveN shaft. This method may be used for drives using three or more sprockets or idlers. For two-sprocket drives, belt pull on the driveR and driveN

shafts is equal but opposite in direction. For drives using idlers, both magnitude and direction may be different.

C. Solution For Magnitude Only

If only the magnitude of belt pull is needed, follow the steps below. Use this method for drives with two sprockets. Use the graphical method shown if the drive uses idlers.

1. Add T_T and T_S
2. Using the value of $\frac{D-d}{C}$ for the drive, find the vector sum correction factor using Fig. 7, where:

D = large diameter
 d = small diameter
 C = center distance

Or, use the arc of contact on the small sprocket if known.

3. Multiply the sum of T_T plus T_S by the vector sum correction factor to find the vector sum of T_T plus T_S .

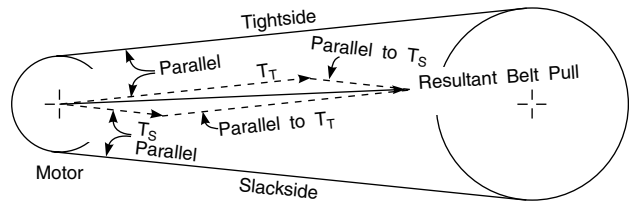

Figure 6

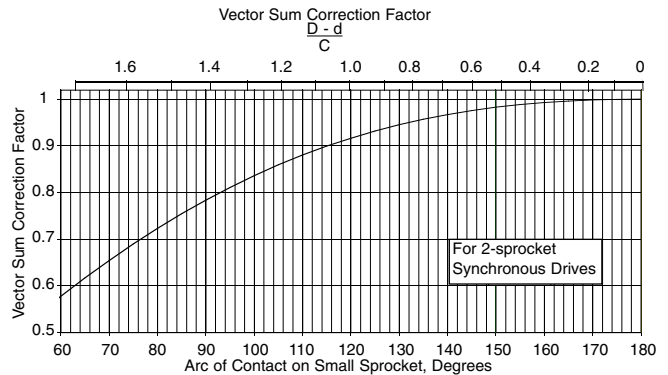

Figure 7

13. Bearing / Shaft Load Calculations

A. Shaft Load Calculations

If true side load on the shaft, including sprocket weight, is desired, the sprocket weight can be added to the belt pull using the same graphical method shown in Fig. 6. The sprocket weight vector is vertical toward the ground. Weights for standard sprockets are shown in the sprocket specification tables.

B. Bearing Load Calculations

In order to find actual bearing loads, it is necessary to know weights of machine components and the value of all other forces contributing to the load. However, it is sometimes desirable to know the bearing load contributed by the synchronous drive alone. Bearing loads resulting from a synchronous belt drive can be calculated knowing bearing placement with respect to the sprocket center and the shaft load as previously calculated. For rough estimates, machine designers sometimes use belt pull alone, ignoring sprocket weight. If accuracy is desired, or if the sprocket is unusually heavy, actual shaft load values including sprocket weight should be used.

A. Overhung Sprocket

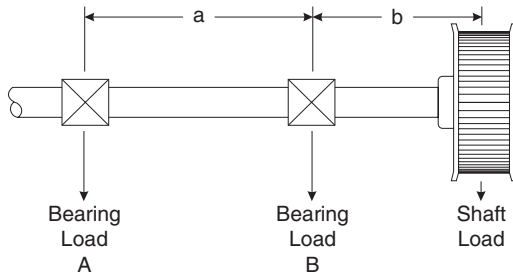

Figure 8

Formula 9

$$\text{Load at B, (lb)} = \frac{\text{Shaft Load} \times (a + b)}{a}$$

Formula 10

$$\text{Load at A, (lb)} = \text{Shaft Load} \times \frac{b}{a}$$

Where: a and b = spacing, (in), per Fig. 8

B. Sprocket Between Bearings

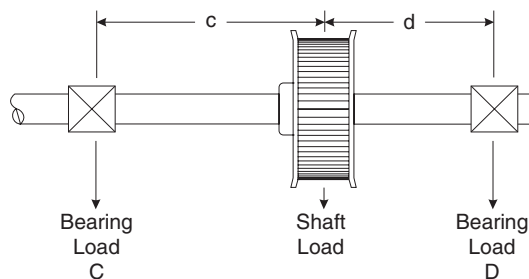

Figure 9

Formula 11

$$\text{Load at D (lb)} = \frac{\text{Shaft Load} \times c}{(c + d)}$$

Formula 12

$$\text{Load at C (lb)} = \frac{\text{Shaft Load} \times d}{(c + d)}$$

Where: c and d = spacing (in), per Fig. 9

14. Self-Generated Tension

All synchronous belt drives exhibit a self-generating or self-tightening characteristic when transmitting a load. Laboratory testing has shown this characteristic is similar with all tooth profiles. The designer/user should be aware that self-tensioning can result in increased bearing and shaft loads and reduced drive performance; i.e., short belt life. This can be avoided by following proper tensioning procedures.

Properly designed and tensioned drives will not be significantly affected by self-generated tension. While belt overtensioning can impose higher bearing and shaft loads and lead to reduced belt life, undertensioning can result in self-tensioning.

When a belt is too loose for the design load, the self-tensioning characteristic results in the belt teeth climbing out of the sprocket grooves, leading to increased stresses on the belt teeth, accelerated tooth wear and reduced belt life.

When a belt is severely undertensioned, the self-tensioning characteristic can result in the belt ratcheting (jumping teeth). When this occurs, significant shaft separation forces are instantaneously developed in the drive, resulting in damage to bearings, shafts, and other drive components including the belt.

NOTE: This is true for all synchronous belts.

Maximum drive performance and belt life are achieved when the belt is properly tensioned for the design load and maintained.

Made-to-order (MTO) PowerGrip® Belts

In addition to the stock industrial PowerGrip® belts listed in this catalog, Gates offers many special construction, made-to-order belts for use with stock sprockets. The table below lists some of them. Contact Gates for more information.

MTO BELT TYPES	APPLICATION
Alternate tensile member	Special applications: i.e., low rpm, shock loads and precise registration.
Nonstock widths and/or lengths in stock pitches	When exact width or length is required.
High temperature	Dry operation from -40°F to 230°F (-40°C to 110°C)
Oil resistance	For excessively oily conditions, including immersion in commercial motor oil. Temperature range: in oil, -20°F to 240°F (-29°C to 116°C); dry, -20°F to 210°F (-29°C to 99°C)
Static dissipating	Resistance of 6 megohms or less.
Low temperature	Dry temperature operation from -65°F to 180°F (-54°C to 82°C)
Nonmarking backing	For conveyors, food handling, etc., with taste and toxicity subject to customer approval.
Precision ground backing	Special applications involving a critical overall belt thickness dimension.
Special thickness rubber backing	For functional and other applications where belt back may require special thickness, durometer or material.
Special tracking	When belt must track in a specific direction.

Troubleshooting

Symptom	Diagnosis	Possible Remedy
Unusual noise	Misaligned drive Too low or high belt tension Backside idler Worn sprocket Bent guide flange Belt speed too high Incorrect belt profile for the sprocket (i.e., GT® etc.) Subminimal diameter Excess load	Correct alignment Adjust tension to recommended value Use inside idler Replace sprocket Replace sprocket/flange Redesign drive Use proper Gates PowerGrip® GT®2 belt/sprocket Redesign drive using larger diameters Redesign drive for increased capacity
Tension loss	Weak support structure Excessive sprocket wear Fixed (nonadjustable) centers Excessive debris Excessive load Subminimal diameter Belt, sprockets or shafts running too hot Unusual belt degradation, such as softening or melting	Reinforce the structure Use alternate sprocket material Use inside idler for belt adjustment Protect drive Redesign drive for increased capacity Redesign drive using larger diameters Check for conductive heat transfer from prime mover Reduce ambient drive temperature to 180°F maximum
Belt tracking	Belt running partly off unflanged sprocket Centers exceed 8 times small sprocket diameter and the large sprocket is not flanged. Excessive belt edge wear	Correct alignment Correct parallel alignment to set belt to track on both sprockets Correct alignment
Flange failure	Belt forcing flanges off	Correct alignment or properly secure flange to sprocket
Excessive belt edge wear	Damage due to handling Flange damage Belt too wide Belt tension too low Rough flange surface finish Improper tracking Belt hitting drive guard or bracketry	Follow proper handling instructions Repair flange or replace sprocket Use proper width sprocket Adjust tension to recommended value Replace or repair flange (to eliminate abrasive surface) Correct alignment Remove obstruction or use inside idler
Premature tooth wear	Too low or high belt tension Belt running partly off unflanged sprocket Misaligned drive Incorrect belt profile for the sprocket (i.e., GT®, etc.) Worn sprocket Rough sprocket teeth Damaged sprocket Sprocket not to dimensional specification Belt hitting drive bracketry or other structure Excessive load Insufficient hardness of sprocket material Excessive debris Cocked bushing/sprocket assembly	Adjust tension to recommended value Correct alignment Correct alignment Use proper Gates PowerGrip® GT®2 belt/sprocket Replace sprocket Replace sprocket Replace sprocket Replace sprocket Remove obstruction or use inside idler Redesign drive for increased capacity Use a more wear-resistant material Protect belt Install bushing per instructions

Troubleshooting

Symptom	Diagnosis	Possible Remedy
Tooth shear	Excessive shock loads Less than 6 teeth-in-mesh Extreme sprocket runout Worn sprocket Backside idler Incorrect belt profile for the sprocket (i.e., GT, etc.) Misaligned drive Belt undertensioned	Redesign drive for increased capacity Redesign drive Replace sprocket Replace sprocket Use inside idler Use proper Gates PowerGrip GT2 belt/sprocket Correct alignment Adjust tension to recommended value
Tensile break	Excessive shock load Subminimal diameter Improper belt handling and storage prior to installation Debris or foreign object in drive Extreme sprocket runout	Redesign drive for increased capacity Redesign drive using larger diameters Follow proper handling and storage procedures Protect drive Replace sprocket
Unusual sprocket wear	Sprocket has too little wear resistance (i.e., plastic, aluminum, softer metals) Misaligned drive Excessive debris Excessive load Too high, too low belt tension Incorrect belt profile (i.e. GT, etc.)	Use alternate sprocket material Correct alignment Protect drive Redesign drive for increased capacity Adjust tension to recommended value Use proper Gates PowerGrip GT2 belt/sprocket
Belt cracking	Subminimal diameter Backside idler Extreme low temperature startup Extended exposure to harsh chemicals Cocked bushing/sprocket assembly	Redesign drive using larger diameters Use inside idler Preheat drive environment Protect drive Install bushing per instructions
Excessive temperature (belt, bearing, housing, shafts, etc.)	Misaligned drive Too low or too high belt tension Incorrect belt profile (i.e. GT, etc.)	Correct alignment Adjust tension to recommended value Use proper Gates PowerGrip GT2 belt/sprocket
Vibration	Incorrect belt profile for the sprocket (i.e. GT, etc.) Too low or too high belt tension Bushing or key loose	Use proper Gates PowerGrip GT2 belt/sprocket Adjust tension to recommended value Check and reinstall per instructions

Standard Calculations

Required	Given	Formula
Speed ratio (R)	Shaft speeds (rpm)	$R = \frac{\text{rpm (faster shaft speed)}}{\text{rpm (slower shaft speed)}}$
	Pulley diameter (D & d)	$R = \frac{D \text{ (larger pulley diameter)}}{d \text{ (smaller pulley diameter)}}$
	Number of pulley grooves (N & n)	$R = \frac{N \text{ (larger pulley groove no.)}}{n \text{ (smaller pulley groove no.)}}$
Horsepower (hp) (33,000 lb-ft/min)	Torque (T) in lb-in Shaft speed (rpm)	$hp = \frac{T \times \text{rpm}}{63,025}$
	Effective tension (Te) in lb. Belt velocity in fpm	$hp = \frac{Te \times V}{33,000}$
Design horsepower (Dhp)	Rated horsepower (hp) Service factor (SF)	$Dhp = hp \times SF$
Power (kw)	Horsepower (hp)	$kw = .7457 \times hp$
Torque (T) in lb-in	Shaft horsepower (hp) Shaft speed (rpm)	$T = \frac{63,025 \times hp}{\text{rpm}}$
	Effective tension (Te) in lbs Pulley radius (R) in inches	$T = Te \times R$
Torque (T) in N-mm	Torque (T) in lb-inches	$T = 112.98 \times T$
Belt velocity in ft/min	Pulley pd in inches Pulley speed in rpm	$V = \frac{pd \times \text{rpm}}{3.82}$
Belt velocity in m/s	Pulley pd in mm Pulley speed in rpm	$V = .0000524 \times pd \times \text{rpm}$
Belt pitch length (PL) in inches (approximate)	Center distance (C) in inches Pulley diameters (D & d) in inches	$PL = 2C + [1.57 \times (D - d)] + \frac{(D - d)^2}{4C}$
Arc of contact on smaller pulley (A/Cs)	Pulley diameters (D & d) in inches Center distance (C) in inches	$A / Cs = 180 - \left[\frac{(D - d) \times 60}{4C} \right]$
Torque (T) due to flywheel effect (WR ²) in lb-inches (accel. and/or decel.)	Final speed (RPM) Initial speed (rpm) Flywheel effect (WR ²) in lbs-ft ² Time (t) in seconds	$T = \frac{.039 \times (\text{RPM} - \text{rpm}) \times WR^2}{t}$
Flywheel effect (WR ²) in lb-ft ²	Face width of rim (F) in inches Material density (Z) in lbs/in ³ Outside rim diameter (D) in inches Inside rim diameter (d) in inches	$WR^2 = \frac{F \times Z \times (D^4 - d^4)}{1467}$

Useful Formulas and Calculations

Power Transmission Conversions

FORCE CONVERSION CONSTANTS

Metric to U.S.

Newtons \times 3.5969 = Ounces_f
Newtons \times 0.2248 = Pounds_f
Kilograms_f \times 2.2046 = Pounds_f

U.S. to Metric

Ounces_f \times 0.2780 = Newtons
Pounds_f \times 4.4482 = Newtons
Pounds_f \times 0.4536 = Kilograms_f

Metric to Metric

Kilograms_f \times 9.8067 = Newtons
Newtons \times 0.1020 = Kilograms_f

TORQUE CONVERSION CONSTANTS

Metric to U.S.

Newton Meters \times 141.6119 = Ounce_f Inches
Newton Meters \times 8.8508 = Pound_f Inches
Newton Meters \times 0.7376 = Pound_f Feet

U.S. to Metric

Ounce_f Inches \times 0.0071 = Newton Meters
Pound_f Inches \times 0.1130 = Newton Meters
Pound_f Feet \times 1.3558 = Newton Meters

Metric to Metric

Newton Meters \times 10.1972 = Kilogram_f Centimeters
Kilogram_f Centimeters \times 0.0981 = Newton Meters
Newton Meters \times 0.1020 = Kilogram_f Meters
Kilogram_f Meters \times 9.8067 = Newton Meters

POWER CONVERSION CONSTANTS

Metric to U.S.

Kilowatt \times 1.3410 = Horsepower
Watt \times 0.0013 = Horsepower

U.S. to Metric

Horsepower \times 745.6999 = Watt
Horsepower \times 0.7457 = Kilowatt

LINEAR BELT SPEED CONVERSION CONSTANTS

Metric to U.S.

Meters per second \times 196.8504 = Feet per Minute

U.S. to U.S.

Feet per Second \times 60.00 = Feet per Minute
Feet per Minute \times 0.0167 = Feet per Second

U.S. to Metric

Feet per Minute \times 0.005080 = Meters per Second
Square Miles \times 2.5900 = Square Kilometers

Other Conversions

LENGTH CONVERSION CONSTANTS

Metric to U.S.

Millimeters \times 0.0394 = Inches
Meters \times 39.3701 = Inches
Meters \times 3.2808 = Feet
Meters \times 1.0936 = Yards
Kilometers \times 3280.84 = Feet
Kilometers \times 0.6214 = Statute Miles
Kilometers \times 0.5396 = Nautical Miles

U.S. to Metric

Inches \times 25.4000 = Millimeters
Inches \times 0.0254 = Meters
Feet \times 0.3048 = Meters
Yards \times 0.9144 = Meters
Feet \times 0.0003048 = Kilometers
Statute Miles \times 1.6093 = Kilometers
Nautical Miles \times 1.8532 = Kilometers

AREA CONVERSION CONSTANTS

Metric to U.S.

Square Millimeters \times 0.0016 = Square Inches
Square Centimeters \times 0.1550 = Square Inches
Square Meters \times 10.7639 = Square Feet
Square Meters \times 1.1960 = Square Yards
Hectares \times 2.4711 = Acres
Square Kilometers \times 247.105 = Acres
Square Kilometers \times 0.3861 = Square Miles

U.S. to Metric

Square Inches \times 645.160 = Square Millimeters
Square Inches \times 6.4516 = Square Centimeters
Square Feet \times 0.0929 = Square Meters
Square Yards \times 0.8361 = Square Meters
Acres \times 0.4047 = Hectares
Acres \times 0.004047 = Square Kilometers
Square Miles \times 2.5900 = Square Kilometers

Useful Formulas and Calculations

Other Conversions — continued

WEIGHT CONVERSION CONSTANTS

Metric to U.S.

Grams \times 15.4324 = Grains
 Grams \times 0.0353 = Ounces (Avd.)
 Grams \times 0.0338 = Fluid Ounces (water)
 Kilograms \times 35.2740 = Ounces (Avd.)
 Kilograms \times 2.2046 = Pounds (Avd.)
 Metric Tons (1000 Kg) \times 1.1023 = Net Ton (2000 lbs.)
 Metric Tons (1000 Kg) \times 0.9842 = Gross Ton (2240 lbs.)

U.S. to Metric

Grains \times 0.0648 = Grams
 Ounces (Avd.) \times 28.3495 = Grams
 Fluid Ounces (water) \times 29.5735 = Grams
 Ounces (Avd.) \times 0.0283 = Kilograms
 Pounds (Avd.) \times 0.4536 = Kilograms
 Net Ton (2000 lbs.) \times 0.9072 = Metric Tons (1000 Kg)
 Gross Ton (2240 lbs.) \times 1.0160 = Metric Tons (1000 Kg)

DECIMAL AND MILLIMETER EQUIVALENTS OF FRACTIONS

Inches		Millimeters	Inches		Millimeters
Fractions	Decimals		Fractions	Decimals	
1/64	.015625	.397	33/64	.515625	13.097
1/32	.03125	.794	17/32	.53125	13.494
3/64	.046875	1.191	35/64	.546875	13.891
1/16	.0625	1.588	9/16	.5625	14.288
5/64	.078125	1.984	37/64	.578125	14.684
3/32	.09375	2.381	19/32	.59375	15.081
7/64	.109375	2.778	39/64	.609375	15.478
1/8	.125	3.175	5/8	.625	15.875
9/64	.140625	3.572	41/64	.640625	16.272
5/32	.15625	3.969	21/32	.65625	16.669
11/64	.171875	4.366	43/64	.671875	17.066
3/16	.1875	4.763	11/16	.6875	17.463
13/64	.203125	5.159	45/64	.703125	17.859
7/32	.21875	5.556	23/32	.71875	18.256
15/64	.234375	5.953	47/64	.734375	18.653
1/4	.250	6.350	3/4	.750	19.050
17/64	.265625	6.747	49/64	.765625	19.447
9/32	.28125	7.144	25/32	.78125	19.844
19/64	.296875	7.541	51/64	.796875	20.241
5/16	.3125	7.938	13/16	.8125	20.638
21/64	.328125	8.334	53/64	.828125	21.034
11/32	.34375	8.731	27/32	.84375	21.431
23/64	.359375	9.128	55/64	.859375	21.828
3/8	.375	9.525	7/8	.875	22.225
25/64	.390625	9.922	57/64	.890625	22.622
13/32	.40625	10.319	29/32	.90625	23.019
27/64	.421875	10.716	59/64	.921875	23.416
7/16	.4375	11.113	15/16	.9375	23.813
29/64	.453125	11.509	61/64	.953125	24.209
15/32	.46875	11.906	31/32	.96875	24.606
31/64	.484375	12.303	63/64	.984375	25.003
1/2	.500	12.700	1	1.000	25.400



Synchronous Belt Product Design Catalogs

Gates Synchronous Belt Products	Pitch	For Design Information Refer to:
Poly Chain® GT®2	8mm, 14mm	Poly Chain® GT®2 Belt Drive Design Manual Catalog 17595
PowerGrip® GT®2	5mm, 8mm, 14mm, 20mm	PowerGrip® Belt Systems Drive Design Manual Catalog 17195
PowerGrip® GT®2	2mm, 3mm	Light Power & Precision Drives Design Manual Catalog 17183
PowerGrip® HTD®	3mm, 5mm	Light Power & Precision Drives Design Manual Catalog 17183
PowerGrip® Timing	XL, L, H	PowerGrip® Belt Systems Drive Design Manual Catalog 17195
PowerGrip® Timing	MXL, XL	Light Power & Precision Drives Design Manual Catalog 17183
Poly Chain® GT® Long Length Belting	8mm, 14mm	PowerGrip® Belt Systems Drive Design Manual Catalog 17195
PowerGrip® Timing Long Length Belting	MXL, XL, L, H	PowerGrip® Belt Systems Drive Design Manual Catalog 17195
PowerGrip® HTD Long Length Belting	3mm, 5mm, 8mm, 14mm HTD	PowerGrip® Belt Systems Drive Design Manual Catalog 17195
PowerGrip® GT® Long Length Belting	2mm, 3mm, 5mm, 8mm PowerGrip GT	PowerGrip® Belt Systems Drive Design Manual Catalog 17195
Synchro-Power Polyurethane Long Length Belting	T5, T10, T20, AT5, AT10, AT20, XL, L, H, XH, 5mm, 8mm, 14mm HTD	PowerGrip® Belt Systems Drive Design Manual Catalog 17195
Twin Power®	XL, L, H PowerGrip Timing, 8mm, 14mm PowerGrip GT2	PowerGrip® Belt Systems Drive Design Manual Catalog 17195

Synchronous Belt Product Listing

Product	Page
Short Length Poly Chain GT	151
Poly Chain GT2	151
PowerGrip GT2	152-154
PowerGrip HTD	155
PowerGrip Timing	156-157
PowerGrip GT2 Twin Power	158
PowerGrip Twin Power Timing	159-160
PowerGrip Timing Long Length Belting	161
Poly Chain GT Long Length Belting	161
PowerGrip HTD Long Length Belting	162
PowerGrip GT Long Length Belting	162
Synchro-Power Polyurethane Long Length Belting	163-164

8mm Pitch Poly Chain GT2 and Short Length Poly Chain® GT® Belts

8M and 8MGT Stock Belt Lengths

Part No.	Pitch Length		No. of Teeth
	(mm)	(in)	
8M-248	248	9.77	31
8M-288	288	11.34	36
8M-352	352	13.86	44
8M-416	416	16.38	52
8M-456	456	17.96	57
8M-480	480	18.90	60
8M-544	544	21.42	68
8M-608	608	23.94	76
8MGT-640	640	25.20	80
8MGT-720	720	28.35	90
8MGT-800	800	31.50	100
8MGT-896	896	35.28	112
8MGT-1000	1000	39.38	125
8MGT-1120	1120	44.10	140

Part No.	Pitch Length		No. of Teeth
	(mm)	(in)	
8MGT-1200	1200	47.25	150
8MGT-1280	1280	50.40	160
8MGT-1440	1440	56.70	180
8MGT-1600	1600	63.00	200
8MGT-1792	1792	70.56	224
8MGT-2000	2000	78.75	250
8MGT-2240	2240	88.20	280
8MGT-2400	2400	94.50	300
8MGT-2520	2520	99.23	315
8MGT-2840	2840	111.83	355
8MGT-3200	3200	126.00	400
8MGT-3600	3600	141.75	450
8MGT-4000	4000	157.50	500
8MGT-4480	4480	176.40	560

8M Short Length Stock Belt Widths

Belt Width Code	Belt Width (mm)	Belt Width (in)
12	12	0.472
21	21	0.827
36	36	1.417

8MGT Stock Belt Widths

Belt Width Code	Belt Width (mm)	Belt Width (in)
12	12	0.472
21	21	0.827
36	36	1.417
62	62	2.441

14mm Pitch Poly Chain GT2 Stock Belts

14MGT Stock Belt Lengths

Part No.	Pitch Length		No. of Teeth
	(mm)	(in)	
14MGT-994	994	39.13	71
14MGT-1120	1120	44.09	80
14MGT-1190	1190	46.85	85
14MGT-1260	1260	49.60	90
14MGT-1400	1400	55.11	100
14MGT-1568	1568	61.73	112
14MGT-1750	1750	68.89	125
14MGT-1890	1890	74.40	135
14MGT-1960	1960	77.16	140
14MGT-2100	2100	82.67	150

Part No.	Pitch Length		No. of Teeth
	(mm)	(in)	
14MGT-2240	2240	88.18	160
14MGT-2380	2380	93.69	170
14MGT-2520	2520	99.20	180
14MGT-2660	2660	104.71	190
14MGT-2800	2800	110.23	200
14MGT-3136	3136	123.45	224
14MGT-3304	3304	130.07	236
14MGT-3500	3500	137.78	250
14MGT-3920	3920	154.32	280
14MGT-4410	4410	173.60	315

14MGT Stock Belt Widths

Belt Width Code	Belt Width (mm)	Belt Width (in)
20	20	0.787
37	37	1.457
68	68	2.677
90	90	3.543
125	125	4.921



2mm Pitch PowerGrip® GT®2 Stock Belts

2MR Stock Belt Lengths

Part No.	Pitch Length		No. of Teeth
	(mm)	(in)	
2MR-100	100	3.94	50
2MR-112	112	4.41	56
2MR-126	126	4.96	63
2MR-134	134	5.28	67
2MR-136	136	5.35	68
2MR-140	140	5.51	70
2MR-152	152	5.98	76
2MR-158	158	6.22	79
2MR-160	160	6.30	80
2MR-164	164	6.46	82
2MR-166	166	6.54	83
2MR-168	168	6.61	84
2MR-172	172	6.77	86
2MR-180	180	7.09	90
2MR-192	192	7.56	96
2MR-200	200	7.87	100
2MR-202	202	7.95	101
2MR-210	210	8.27	105
2MR-212	212	8.35	106
2MR-216	216	8.50	108
2MR-220	220	8.66	110
2MR-232	232	9.13	116
2MR-236	236	9.29	118
2MR-240	240	9.45	120
2MR-250	250	9.84	125
2MR-252	252	9.92	126
2MR-258	258	10.16	129

Part No.	Pitch Length		No. of Teeth
	(mm)	(in)	
2MR-278	278	10.94	139
2MR-280	280	11.02	140
2MR-300	300	11.81	150
2MR-320	320	12.60	160
2MR-322	322	12.68	161
2MR-346	346	13.62	173
2MR-350	350	13.78	175
2MR-364	364	14.33	182
2MR-370	370	14.57	185
2MR-380	380	14.96	190
2MR-386	386	15.20	193
2MR-400	400	15.75	200
2MR-406	406	15.98	203
2MR-420	420	16.54	210
2MR-456	456	17.95	228
2MR-470	470	18.50	235
2MR-474	474	18.66	237
2MR-488	488	19.21	244
2MR-504	504	19.84	252
2MR-528	528	20.79	264
2MR-552	552	21.73	276
2MR-576	576	22.68	288
2MR-600	600	23.62	300
2MR-640	640	25.20	320
2MR-696	696	27.40	348
2MR-744	744	29.29	372
2MR-1164	1164	45.83	582

2MR Stock Belt Widths

Belt Width Code	Belt Width (mm)	Belt Width (in)
04	4	0.157
06	6	0.236
09	9	0.354

3mm Pitch PowerGrip GT2 Stock Belts

3MR Stock Belt Lengths

Part No.	Pitch Length		No. of Teeth
	(mm)	(in)	
3MR-165	165	6.50	55
3MR-189	189	7.44	63
3MR-201	201	7.91	67
3MR-219	219	8.62	73
3MR-225	225	8.86	75
3MR-240	240	9.45	80
3MR-243	243	9.57	81
3MR-267	267	10.51	89
3MR-282	282	11.10	94
3MR-291	291	11.46	97
3MR-300	300	11.81	100
3MR-339	339	13.35	113
3MR-348	348	13.70	116
3MR-357	357	14.06	119
3MR-360	360	14.17	120
3MR-375	375	14.76	125
3MR-420	420	16.54	140

Part No.	Pitch Length		No. of Teeth
	(mm)	(in)	
3MR-447	447	17.60	149
3MR-450	450	17.72	150
3MR-474	474	18.66	158
3MR-480	480	18.90	160
3MR-483	483	19.02	161
3MR-489	489	19.25	163
3MR-537	537	21.14	179
3MR-600	600	23.62	200
3MR-630	630	24.80	210
3MR-684	684	26.93	228
3MR-750	750	29.53	250
3MR-840	840	33.07	280
3MR-945	945	37.20	315
3MR-1050	1050	41.34	350
3MR-1080	1080	42.52	360
3MR-1536	1536	60.47	512
3MR-2061	2062	81.18	687

3MR Stock Belt Widths

Belt Width Code	Belt Width (mm)	Belt Width (in)
06	6	0.236
09	9	0.354
15	15	0.591

5mm Pitch PowerGrip® GT®2 Stock Belt Lengths

5MR Stock Belt Lengths

Part No.	Pitch Length		No. of Teeth
	(mm)	(in)	
5MR-300	300	11.81	60
5MR-355	355	13.98	71
5MR-375	375	14.76	75
5MR-400	400	15.75	80
5MR-405	405	15.94	81
5MR-425	425	16.73	85
5MR-450	450	17.72	90
5MR-500	500	19.69	100
5MR-535	535	21.06	107
5MR-565	565	22.24	113
5MR-580	580	22.83	116
5MR-600	600	23.62	120
5MR-625	625	24.61	125

Part No.	Pitch Length		No. of Teeth
	(mm)	(in)	
5MR-650	650	25.59	130
5MR-700	700	27.56	140
5MR-750	750	29.53	150
5MR-800	800	31.50	160
5MR-850	850	33.46	170
5MR-900	900	35.43	180
5MR-1000	1000	39.37	200
5MR-1150	1150	45.28	230
5MR-1300	1300	51.18	260
5MR-1450	1450	57.09	290
5MR-1600	1600	62.99	320
5MR-1720	1720	67.72	344
5MR-2100	2100	82.67	420

5MR Stock Belt Widths

Belt Width Code	Belt Width (mm)	Belt Width (in)
09	9	0.354
15	15	0.591
25	25	0.984

8mm Pitch PowerGrip GT2 Belts

8MGT Stock Belt Lengths

Part No.	Pitch Length		No. of Teeth
	(mm)	(in)	
384-8MGT	384	15.12	48
480-8MGT	480	18.89	60
560-8MGT	560	22.05	70
600-8MGT	600	23.62	75
640-8MGT	640	25.20	80
720-8MGT	720	28.35	90
800-8MGT	800	31.50	100
840-8MGT	840	33.07	105
880-8MGT	880	34.65	110
920-8MGT	920	36.22	115
960-8MGT	960	37.80	120
1040-8MGT	1040	40.94	130
1064-8MGT	1064	41.89	133
1120-8MGT	1120	44.09	140
1160-8MGT	1164	45.67	145
1200-8MGT	1200	47.24	150
1224-8MGT	1224	48.19	153

Part No.	Pitch Length		No. of Teeth
	(mm)	(in)	
1280-8MGT	1280	50.39	160
1440-8MGT	1440	56.69	180
1512-8MGT	1512	59.53	189
1584-8MGT	1584	62.36	198
1600-8MGT	1600	62.99	200
1760-8MGT	1760	69.29	220
1800-8MGT	1800	70.87	225
2000-8MGT	2000	78.74	250
2200-8MGT	2200	86.61	275
2400-8MGT	2400	94.49	300
2600-8MGT	2600	102.36	325
2800-8MGT	2800	110.24	350
3048-8MGT	3048	120.00	381
3280-8MGT	3280	129.13	410
3600-8MGT	3600	141.73	450
4400-8MGT	4400	173.23	550

8MGT Stock Belt Widths

Belt Width Code	Belt Width (mm)	Belt Width (in)
20	20	0.787
30	30	1.181
50	50	1.969
85	85	3.346

Refer to the Industrial Power Transmission Products catalog, 19993, for a listing of 8mm and 14mm pitch PowerGrip GT belts for replacement use on existing PowerGrip GT or HTD drives.



14mm Pitch PowerGrip® GT² Belts

14MGT Stock Belt Lengths

Part No.	Pitch Length		No. of Teeth
	(mm)	(in)	
966-14MGT	966	38.03	69
1190-14MGT	1190	46.85	85
1400-14MGT	1400	55.12	100
1610-14MGT	1610	63.39	115
1778-14MGT	1778	70.00	127
1890-14MGT	1890	74.41	135
2100-14MGT	2100	82.63	150
2310-14MGT	2310	90.94	165
2450-14MGT	2450	96.46	175
2590-14MGT	2590	101.97	185
2800-14MGT	2800	110.24	200

Part No.	Pitch Length		No. of Teeth
	(mm)	(in)	
3150-14MGT	3150	124.02	225
3360-14MGT	3360	132.28	240
3500-14MGT	3500	137.80	250
3850-14MGT	3850	151.57	275
4326-14MGT	4326	170.32	309
4578-14MGT	4578	180.24	327
4956-14MGT	4956	195.12	354
5320-14MGT	5320	209.45	380
5740-14MGT	5740	225.98	410
6160-14MGT	6160	242.52	440
6860-14MGT	6860	270.08	490

14MGT Stock Belt Widths

Belt Width Code	Belt Width (mm)	Belt Width (in)
40	40	1.575
55	55	2.165
85	85	3.346
115	115	4.528
170	170	6.693

Refer to the Industrial Power Transmission Products catalog, 19993, for a listing of 8mm and 14mm pitch PowerGrip GT belts for replacement use on existing PowerGrip GT or HTD drives.

20mm Pitch PowerGrip GT² Stock Belt Lengths

20M Stock Belt Lengths

Part No.	Pitch Length		No. of Teeth
	(mm)	(in)	
2000-20M	2000	78.74	100
2500-20M	2500	98.43	125
3400-20M	3400	133.86	170
3800-20M	3800	149.61	190
4200-20M	4200	165.35	210
4600-20M	4600	181.10	230
5000-20M	5000	196.85	250
5200-20M	5200	204.72	260

Part No.	Pitch Length		No. of Teeth
	(mm)	(in)	
5400-20M	5400	212.60	270
5600-20M	5600	220.47	280
5800-20M	5800	228.35	290
6000-20M	6000	236.22	300
6200-20M	6200	244.09	310
6400-20M	6400	251.97	320
6600-20M	6600	259.84	330

20M Stock Belt Widths

Belt Width Code	Belt Width (mm)	Belt Width (in)
115	115	4.528
170	170	6.693
230	230	9.055
290	290	11.417
340	340	13.386

3mm Pitch PowerGrip® HTD® Belts

3M Stock Belt Widths

Part No.	Pitch Length		No. of Teeth
	(mm)	(in)	
150-3M	150	5.91	50
159-3M	159	6.26	53
168-3M	168	6.61	56
177-3M	177	6.97	59
189-3M	189	7.44	63
201-3M	201	7.91	67
213-3M	213	8.39	71
225-3M	225	8.86	75
240-3M	240	9.45	80
252-3M	252	9.92	84
255-3M	255	10.04	85
267-3M	267	10.51	89
285-3M	285	11.22	95
300-3M	300	11.81	100
312-3M	312	12.28	104
318-3M	318	12.52	106
339-3M	339	13.35	113
357-3M	357	14.06	119
363-3M	363	14.29	121
384-3M	384	15.12	128
390-3M	390	15.35	130
399-3M	399	15.71	133

Part No.	Pitch Length		No. of Teeth
	(mm)	(in)	
420-3M	420	16.54	140
447-3M	447	17.60	149
474-3M	474	18.66	158
486-3M	486	19.13	162
501-3M	501	19.72	167
513-3M	513	20.20	171
531-3M	531	20.91	177
564-3M	564	22.20	188
597-3M	597	23.50	199
633-3M	633	24.92	211
669-3M	669	26.34	223
711-3M	711	27.99	237
753-3M	753	29.65	251
795-3M	795	31.30	265
843-3M	843	33.19	281
882-3M	882	34.72	294
945-3M	945	37.20	315
1002-3M	1002	39.45	334
1062-3M	1062	41.81	354
1125-3M	1125	44.29	375
1191-3M	1191	46.89	397
1263-3M	1263	49.72	421

3M HTD Stock Belt Widths

Belt Width Code	Belt Width (mm)	Belt Width (in)
06	6	0.236
09	9	0.354
15	15	0.591

5mm Pitch PowerGrip HTD Belts

5M Stock Belt Widths

Part No.	Pitch Length		No. of Teeth
	(mm)	(in)	
350-5M	350	13.78	70
375-5M	375	14.76	75
400-5M	400	15.75	80
425-5M	425	16.73	85
450-5M	450	17.72	90
475-5M	475	18.70	95
500-5M	500	19.69	100
535-5M	535	21.06	107
565-5M	565	22.24	113
600-5M	600	23.62	120
635-5M	635	25.00	127
670-5M	670	26.38	134
710-5M	710	27.95	142
740-5M	740	29.13	148
800-5M	800	31.50	160
850-5M	850	33.46	170

Part No.	Pitch Length		No. of Teeth
	(mm)	(in)	
890-5M	890	35.04	178
950-5M	950	37.40	190
1000-5M	1000	39.37	200
1050-5M	1050	41.34	210
1125-5M	1125	44.29	225
1195-5M	1195	47.05	239
1270-5M	1270	50.00	254
1420-5M	1420	55.91	284
1595-5M	1595	62.80	319
1690-5M	1690	66.54	338
1790-5M	1790	70.47	358
1895-5M	1895	74.61	379
2000-5M	2000	78.74	400
2250-5M	2250	88.58	450
2525-5M	2525	99.40	505

5M HTD Stock Belt Widths

Belt Width Code	Belt Width (mm)	Belt Width (in)
09	9	0.354
15	15	0.591
25	25	0.984



MXL Pitch PowerGrip® Timing Belts

MXL Stock Belt Lengths

Part No.	Pitch Length (in)	No. of Teeth
36MXL	3.60	45
40MXL	4.00	50
44MXL	4.40	55
48MXL	4.80	60
56MXL	5.60	70
64MXL	6.40	80
68MXL	6.80	85
72MXL	7.20	90
76MXL	7.60	95
80MXL	8.00	100
88MXL	8.80	110
96MXL	9.60	120
104MXL	10.40	130

Part No.	Pitch Length (in)	No. of Teeth
112MXL	11.20	140
120MXL	12.00	150
132MXL	13.20	165
140MXL	14.00	175
152MXL	15.20	190
160MXL	16.00	200
168MXL	16.80	210
180MXL	18.00	225
200MXL	20.00	250
208MXL	20.80	260
236MXL	23.60	295
240MXL	24.00	300
320MXL	32.00	400

MXL Stock Belt Widths

Belt Width Code	Belt Width (in)
012	0.125
019	0.188
025	0.250

XL Pitch PowerGrip Timing Belts

XL Stock Belt Lengths

Part No.	Pitch Length (in)	No. of Teeth
50XL	5.00	25
60XL	6.00	30
70XL	7.00	35
80XL	8.00	40
90XL	9.00	45
100XL	10.00	50
110XL	11.00	55
120XL	12.00	60
130XL	13.00	65
140XL	14.00	70
150XL	15.00	75
160XL	16.00	80
170XL	17.00	85
180XL	18.00	90
190XL	19.00	95
200XL	20.00	100
210XL	21.00	105
220XL	22.00	110
230XL	23.00	115
240XL	24.00	120
250XL	25.00	125

Part No.	Pitch Length (in)	No. of Teeth
260XL	26.00	130
280XL	28.00	140
290XL	29.00	145
300XL	30.00	150
310XL	31.00	155
330XL	33.00	165
340XL	34.00	170
350XL	35.00	175
370XL	37.00	185
380XL	38.00	190
390XL	39.00	195
400XL	40.00	200
420XL	42.00	210
450XL	45.00	225
460XL	46.00	230
480XL	48.00	240
500XL	50.00	250
570XL	57.00	285
630XL	63.00	315
770XL	77.00	385

XL Stock Belt Widths

Belt Width Code	Belt Width (in)
025	0.250
037	0.375

L Pitch PowerGrip® Timing Belts

L Stock Belt Lengths

Part No.	Pitch Length (in)	No. of Teeth
124L	12.38	33
135L	13.50	36
150L	15.00	40
165L	16.50	44
187L	18.75	50
195L	19.50	52
210L	21.00	56
225L	22.50	60
240L	24.00	64
255L	25.50	68
270L	27.00	72
285L	28.50	76
300L	30.00	80
315L	31.50	84

Part No.	Pitch Length (in)	No. of Teeth
322L	32.25	86
345L	34.50	92
367L	36.75	98
390L	39.00	104
420L	42.00	112
450L	45.00	120
480L	48.00	128
510L	51.00	136
540L	54.00	144
600L	60.00	160
660L	66.00	176
817L	81.75	218
900L	90.00	240

L Stock Belt Widths

Belt Width Code	Belt Width (in)
050	0.500
075	0.750
100	1.000

H Pitch PowerGrip Timing Belts

H Stock Belt Lengths

Part No.	Pitch Length	No. of Teeth
210H	21.00	42
220H	22.00	44
230H	23.00	46
240H	24.00	48
270H	27.00	54
300H	30.00	60
320H	32.00	64
330H	33.00	66
340H	34.00	68
350H	35.00	70
360H	36.00	72
370H	37.00	74
390H	39.00	78
400H	40.00	80
410H	41.00	82
420H	42.00	84
450H	45.00	90
480H	48.00	96
490H	49.00	98
510H	51.00	102
540H	54.00	108
560H	56.00	112
570H	57.00	114

Part No.	Pitch Length	No. of Teeth
585H	58.50	117
600H	60.00	120
630H	63.00	126
645H	64.50	129
660H	66.00	132
700H	70.00	140
730H	73.00	146
750H	75.00	150
780H	78.00	156
800H	80.00	160
820H	82.00	164
840H	84.00	168
850H	85.00	170
900H	90.00	180
960H	96.00	192
1000H	100.00	200
1100H	110.00	220
1140H	114.00	228
1250H	125.00	250
1400H	140.00	280
1550H	155.00	310
1700H	170.00	340

H Stock Belt Widths

Belt Width Code	Belt Width (in)
75	0.750
100	1.000
150	1.500
200	2.000
300	3.000

Refer to the Industrial Power Transmission Products catalog, 19993, for a listing of XH and XXH PowerGrip Timing belts for replacement use on existing drives.

8mm Pitch PowerGrip® GT² Twin Power® Belts

TP 8MGT Stock Belt Lengths

Part No.	Pitch Length		No. of Teeth
	(mm)	(in)	
TP840-8MGT	840	33.08	105
TP880-8MGT	880	34.65	110
TP920-8MGT	920	36.23	115
TP960-8MGT	960	37.80	120
TP1040-8MGT	1040	40.95	130
TP1120-8MGT	1120	44.10	140
TP1200-8MGT	1200	47.25	150
TP1224-8MGT	1224	48.20	153
TP1280-8MGT	1280	50.40	160
TP1440-8MGT	1440	56.70	180
TP1600-8MGT	1600	63.00	200

Part No.	Pitch Length		No. of Teeth
	(mm)	(in)	
TP1760-8MGT	1760	69.30	220
TP1800-8MGT	1800	70.88	225
TP2000-8MGT	2000	78.75	250
TP2200-8MGT	2200	86.63	275
TP2400-8MGT	2400	94.50	300
TP2600-8MGT	2600	102.38	325
TP2800-8MGT	2800	110.25	350
TP3048-8MGT	3048	120.02	381
TP3280-8MGT	3280	129.15	410
TP3600-8MGT	3600	141.75	450
TP4400-8MGT	4400	173.25	550

8MGT2 Twin Power Stock Belt Widths

Belt Width Code	Belt Width (mm)	Belt Width (in)
20	20	0.787
30	30	1.181
50	50	1.969
85	85	3.346

14mm Pitch PowerGrip GT² Twin Power Belts

TP 14MGT Stock Belt Lengths

Part No.	Pitch Length		No. of Teeth
	(mm)	(in)	
TP966-14MGT	966	38.03	69
TP1190-14MGT	1190	46.85	85
TP1400-14MGT	1400	55.12	100
TP1610-14MGT	1610	63.38	115
TP1778-14MGT	1778	70.00	127
TP1890-14MGT	1890	74.41	135
TP2100-14MGT	2100	82.67	150
TP2310-14MGT	2310	90.94	165
TP2450-14MGT	2450	96.45	175

Part No.	Pitch Length		No. of Teeth
	(mm)	(in)	
TP2590-14MGT	2590	101.96	185
TP2800-14MGT	2800	110.23	200
TP3150-14MGT	3150	124.01	225
TP3360-14MGT	3360	132.28	240
TP3500-14MGT	3500	137.79	250
TP3850-14MGT	3850	151.57	275
TP4326-14MGT	4326	170.31	309
TP4578-14MGT	4578	180.23	327

14MGT2 Twin Power Stock Belt Widths

Belt Width Code	Belt Width (mm)	Belt Width (in)
40	40	1.575
55	55	2.165
85	85	3.346

Refer to the Industrial Power Transmission Products catalog, 19993, for a listing of 8mm and 14mm pitch PowerGrip GT Twin Power belts for replacement use on existing PowerGrip GT or HTD Twin Power drives.

XL Pitch PowerGrip® Twin Power® Timing Belts

Stock Belt Lengths

Part No.	Pitch Length (in)	No. of Teeth
TP140XL	14.00	70
TP150XL	15.00	75
TP160XL	16.00	80
TP170XL	17.00	85
TP180XL	18.00	90
TP190XL	19.00	95
TP200XL	20.00	100
TP210XL	21.00	105
TP220XL	22.00	110
TP230XL	23.00	115

Part No.	Pitch Length (in)	No. of Teeth
TP240XL	24.00	120
TP250XL	25.00	125
TP260XL	26.00	130
TP270XL	27.00	135
TP280XL	28.00	140
TP290XL	29.00	145
TP300XL	30.00	150
TP310XL	31.00	155
TP330XL	33.00	165
TP340XL	34.00	170

XL Twin Power Stock Belt Widths

Belt Width Code	Belt Width (in)
025	0.250
037	0.375

L Pitch PowerGrip Twin Power Timing Belts

Stock Belt Lengths

Part No.	Pitch Length (in)	No. of Teeth
TP150L	15.00	40
TP165L	16.50	44
TP187L	18.75	50
TP195L	19.50	52
TP210L	21.00	56
TP225L	22.50	60
TP240L	24.00	64
TP255L	25.50	68
TP270L	27.00	72
TP285L	28.50	76
TP300L	30.00	80
TP322L	32.25	86

Part No.	Pitch Length (in)	No. of Teeth
TP345L	34.50	92
TP367L	36.75	98
TP390L	39.00	104
TP420L	42.00	112
TP450L	45.00	120
TP480L	48.00	128
TP510L	51.00	136
TP540L	54.00	144
TP600L	60.00	160
TP660L	66.00	176
TP817L	81.75	218

L Twin Power, Stock Belt Widths

Belt Width Code	Belt Width (in)
050	0.500
075	0.750
100	1.000



H Pitch PowerGrip® Twin Power® Timing Belts

Stock Belt Lengths

Part No.	Pitch Length (in)	No. of Teeth
TP240H	24.00	48
TP270H	27.00	54
TP300H	30.00	60
TP330H	33.00	66
TP350H	35.00	70
TP360H	36.00	72
TP390H	39.00	78
TP400H	40.00	80
TP420H	42.00	84
TP450H	45.00	90
TP480H	48.00	96
TP510H	51.00	102
TP540H	54.00	108
TP570H	57.00	114

Part No.	Pitch Length (in)	No. of Teeth
TP600H	60.00	120
TP630H	63.00	126
TP660H	66.00	132
TP700H	70.00	140
TP750H	75.00	150
TP800H	80.00	160
TP850H	85.00	170
TP900H	90.00	180
TP1000H	100.00	200
TP1100H	110.00	220
TP1250H	125.00	250
TP1400H	140.00	280
TP1700H	170.00	340

H Twin Power Stock Belt Widths

Belt Width Code	Belt Width (in)
075	0.750
100	1.000
150	1.500
200	2.000
300	3.000

PowerGrip® Timing — Long Length Belting

Mini-Pitch (0.080/MXL) — Fiberglass Tensile

Part No.	Product No.	Width (in)	Net Wt. /ft. (lbs)
LL025MXL	9314-2020	1/4	0.01
LL037MXL	9314-2014	3/8	0.02
LL050MXL	9314-2038	1/2	0.02

1/5 Pitch (0.200/XL) - Steel Tensile

Part No.	Product No.	Width (in)	Net Wt. /ft. (lbs)
LL025XLST	9314-10028	1/4	0.064
LL037XLST	9314-10029	3/8	0.072
LL050XLST	9314-10030	1/2	0.082

1/5 Pitch (0.200/XL) - Fiberglass Tensile

Part No.	Product No.	Width (in)	Net Wt. /ft. (lbs)
LL025XL	9314-0001	1/4	0.01
LL037XL	9314-0002	3/8	0.01
LL050XL	9314-2012	1/2	0.03
LL075XL	9314-2090	3/4	0.04

3/8 Pitch (0.375/L) - Steel Tensile

Part No.	Product No.	Width (in)	Net Wt. /ft. (lbs)
LL050LST	9314-10035	1/2	0.163
LL075LST	9314-10036	3/4	0.198

3/8 Pitch (0.375/L) - Fiberglass Tensile

Part No.	Product No.	Width (in)	Net Wt. /ft. (lbs)
LL037L	9314-2089	3/8	0.02
LL050L	9314-0004	1/2	0.02
LL075L	9314-0007	3/4	0.04
LL100L	9314-0015	1	0.05

1/2" Pitch (0.500"/H) - Steel Tensile

Part No.	Product No.	Width (in)	Net Wt. /ft. (lbs)
LL075HST	9314-10011	3/4	0.229
LL100HST	9314-10037	1	0.253

1/2" Pitch (0.500"/H) - Fiberglass Tensile

Part No.	Product No.	Width (in)	Net Wt. /ft. (lbs)
LL050H	9314-0003	1/2	0.04
LL075H	9314-0006	3/4	0.06
LL100H	9314-0008	1	0.12
LL150H	9314-0017	1 1/2	0.12
LL200H	9314-0021	2	0.16
LL300H	9314-0025	3	0.24

Poly Chain GT Long Length Belting

8mm - 14mm Pitch

Part No.	Product No.	Width (in)	Net Wt. /ft. (lbs)
LL8M012GT	9305-0001	12	0.03
LL8M021GT	9305-0002	21	0.06
LL8M036GT	9305-0003	36	0.11
LL14M020GT	9305-0005	20	0.10
LL14M037GT	9305-0006	37	0.19



PowerGrip® HTD® — Long Length Belting

PowerGrip HTD - Long Length Belting

PowerGrip HTD Belting - Fiberglass Tensile 3mm - 5mm - 8mm - 14mm Pitch

Part No.	Product No.	Width (in)	Net Wt. /ft. (lbs)
LL3M06	9308-0044	6	0.01
LL3M09	9308-0003	9	0.01
LL3M15	9308-0084	15	0.01
LL5M09	9308-0045	9	0.01
LL5M15	9308-0033	15	0.01
LL5M25	9308-0025	25	0.05
LL8M20	9308-0001	20	0.08
LL8M30	9308-0004	30	0.13
LL8M50	9308-0005	50	0.21
LL8M85	9308-0006	85	0.36
LL14M40	9308-10009	40	0.26
LL14M55	9308-10020	55	0.35
LL14M85	9308-10057	85	0.55

PowerGrip HTD Belting - Steel Tensile 14mm Pitch

Part No.	Product No.	Width (in)	Net Wt. /ft. (lbs)
LL14M40ST	9308-10016	40	0.76
LL14M55ST	9308-10051	55	1.02
LL14M85ST	9308-10084	85	1.51

PowerGrip GT - Long Length Belting

PowerGrip GT - Fiberglass Tensile 2mm - 3mm - 5mm - 8mm Pitch

Part No.	Product No.	Width (in)	Net Wt. /ft. (lbs)
LL2MR04	9396-0033	4	0.01
LL2MR06	9396-0009	6	0.01
LL2MR09	9396-0011	9	0.01
LL3MR06	9396-0002	6	0.01
LL3MR09	9396-0012	9	0.01
LL3MR15	9396-0021	15	0.01
LL5MR09	9396-0020	9	0.01
LL5MR15	9396-0025	15	0.01
LL5MR25	9396-0018	25	0.05
LL8MR20	9396-0029	20	0.08
LL8MR30	9396-0030	30	0.13
LL8MR50	9396-0031	50	0.21
LL8MR85	9396-0032	85	0.36

PowerGrip GT - Steel Tensile 5mm - 8mm Pitch

Part No.	Product No.	Width (in)	Net Wt. /ft. (lbs)
LL5MR15ST	9308-10043	15	0.18
LL5MR25ST	9308-40417	25	0.23
LL8MR20ST	9308-10049	20	0.29
LL8MR30ST	9308-10050	30	0.37
LL8MR50ST	9308-40433	50	0.53

Synchro-Power® PolyUrethane Long Length Belting

T5 Pitch

Part No.	Width (mm)	Wt. per ft. (lbs)
U6T5LL	6	.01
U8T5LL	8*	.01
U10T5LL	10	.02
U12T5LL	12*	.02
U16T5LL	16	.03
U20T5LL	20*	.03
U25T5LL	25	.04
U32T5LL	32	.05
U50T5LL	50	.08

AT5 Pitch

Part No.	Width (mm)	Wt. per ft. (lbs)
U6AT5LL	6	.01
U10AT5LL	10	.02
U16AT5LL	16	.03
U20AT5LL	20	.04
U25AT5LL	25	.05
U32AT5LL	32	.06
U50AT5LL	50	.10

T10 Pitch

Part No.	Width (mm)	Wt. per ft. (lbs)
U12T10LL	12*	.04
U16T10LL	16	.05
U20T10LL	20*	.07
U25T10LL	25	.08
U32T10LL	32	.11
U40T10LL	40*	.13
U50T10LL	50	.16
U75T10LL	75	.25
U100T10LL	100	.33

AT10 Pitch

Part No.	Width (mm)	Wt. per ft. (lbs)
U16AT10LL	16	.06
U20AT10LL	20*	.08
U25AT10LL	25	.10
U32AT10LL	32	.13
U40AT10LL	40*	.16
U50AT10LL	50	.20
U75AT10LL	75*	.30
U100AT10LL	100*	.40

T20 Pitch

Part No.	Width (mm)	Wt. per ft. (lbs)
U25T20LL	25*	.13
U32T20LL	32*	.17
U50T20LL	50*	.27
U75T20LL	75*	.40
U100T20LL	100*	.54

*Standard/Non-Stock item, may require manufacturing lead time.

AT20 Pitch

Part No.	Width (mm)	Wt. per ft. (lbs)
U25AT20LL	25*	.17
U32AT20LL	32*	.22
U50AT20LL	50*	.34
U75AT20LL	75*	.50
U100AT20LL	100*	.67
U120AT20LL	120*	.81
U150AT20LL	150*	1.01

*Standard/Non-Stock item, may require manufacturing lead time.



Synchro-Power® PolyUrethane Long Length Belting

1/5" Pitch (0.200"/XL)

Part No.	Width (mm)	Wt. per ft. (lbs)
U.25INXL LL	.250*	.01
U.31INXL LL	.310*	.01
U.375INXL LL	.375*	.01
U.50INXL LL	.500*	.02
U.75INXL LL	.750*	.03
U1.00INXL LL	1.000*	.03
U2.00INXL LL	2.000*	.07

5mm Pitch HTD

Part No.	Width (mm)	Wt. per ft. (lbs)
U10MTD5MLL	10*	.03
U15MTD5MLL	15*	.04
U25MTD5MLL	25*	.07
U50MTD5MLL	50*	.13

3/8" Pitch (0.375"/L)

Part No.	Width (mm)	Wt. per ft. (lbs)
U.375INL LL	.375	.02
U.50INL LL	.500	.02
U.75INL LL	.750	.03
U1.00INL LL	1.000	.04
U1.50INL LL	1.500*	.06
U2.00INL LL	2.000*	.08

8mm Pitch HTD

Part No.	Width (mm)	Wt. per ft. (lbs)
U10MTD8MLL	10*	.04
U15MTD8MLL	15*	.06
U20MTD8MLL	20*	.08
U30MTD8MLL	30*	.13
U50MTD8MLL	50*	.21
U85MTD8MLL	85*	.36
U100MTD8MLL	100*	.42

1/2" Pitch (0.500"/H)

Part No.	Width (mm)	Wt. per ft. (lbs)
U.50INH LL	.500	.02
U.75INH LL	.750	.04
U1.00INH LL	1.000	.05
U1.50INH LL	1.500	.07
U2.00INH LL	2.000	.09
U3.00INH LL	3.000*	.14
U4.00INH LL	4.000*	.19

14MM Pitch HTD

Part No.	Width (mm)	Wt. per ft. (lbs)
U25MTD14MLL	25*	.19
U40MTD14MLL	40*	.30
U55MTD14MLL	55*	.41
U85MTD14MLL	85*	.64
U100MTD14MLL	100*	.75

*Standard/Non-Stock item, may require manufacturing lead time.

7/8" Pitch (0.875"/XH)

Part No.	Width (mm)	Wt. per ft. (lbs)
U1.00INXHLL	1.000*	.22
U1.50INXHLL	1.500*	.32
U2.00INXHLL	2.000*	.43
U3.00INXHLL	3.000*	.65
U4.00INXHLL	4.000*	.86

*Standard/Non-Stock item, may require manufacturing lead time.

Application Examples

The following illustrations show a few of the many ways that PowerGrip belt drives can be used to transmit both power and motion. Synchronous belt drive systems are amazingly versatile, yet reliable and efficient. The examples that follow utilize conventional endless, Long-Length and Twin Power belting, all of which is readily available.

Common Drive Configurations

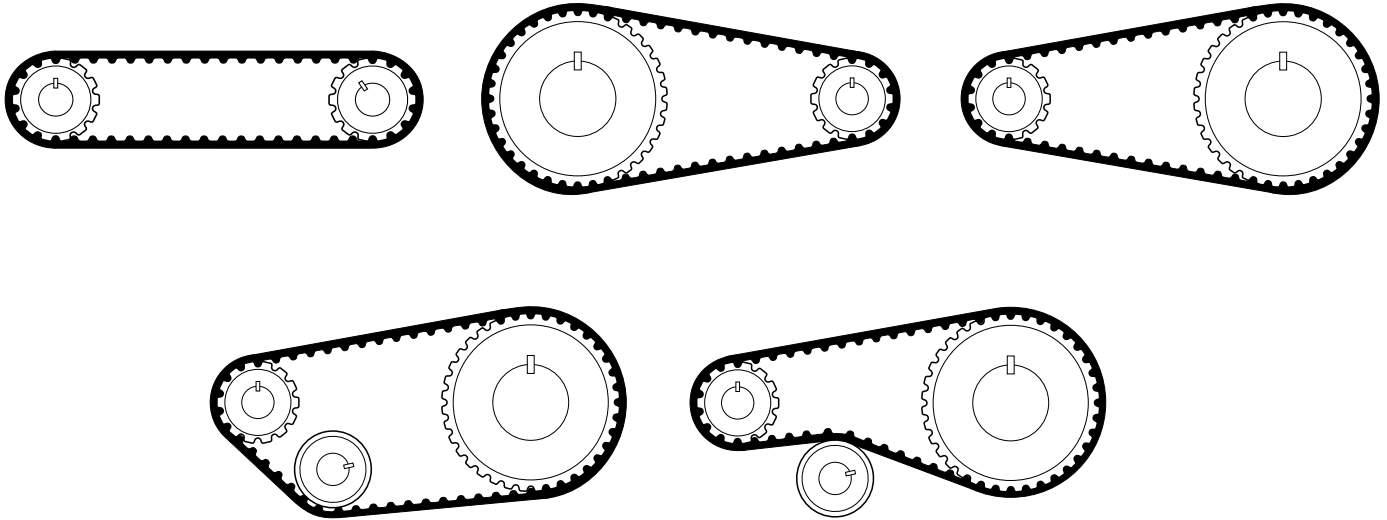

Multiple Shaft Drive Configurations

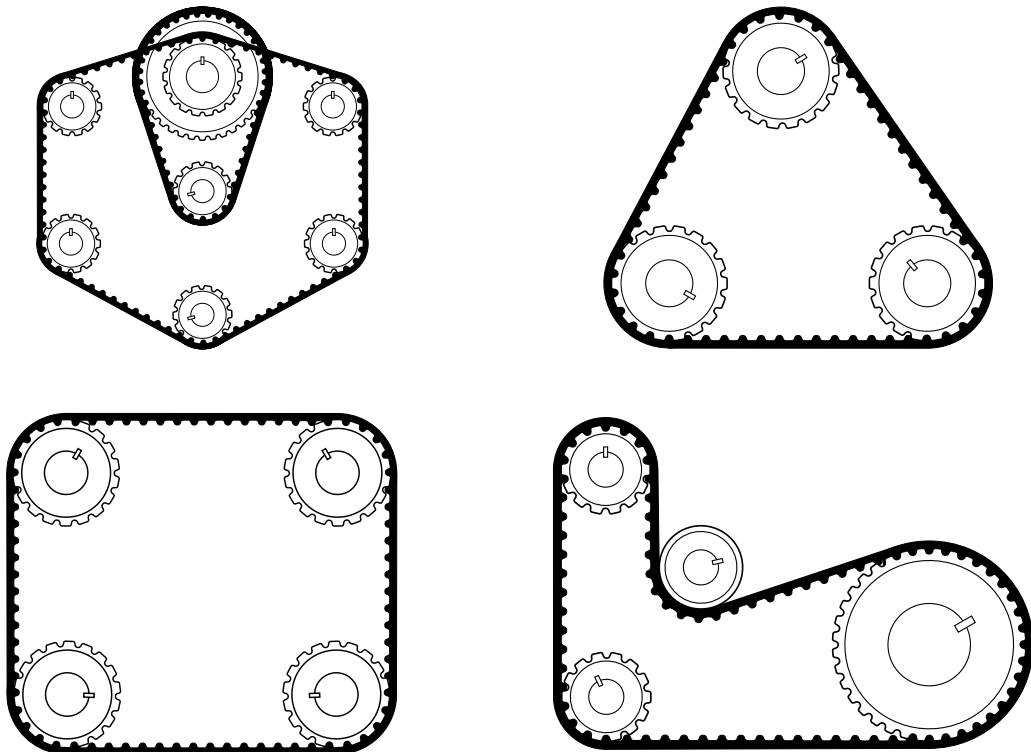

Serpentine Drive Configurations

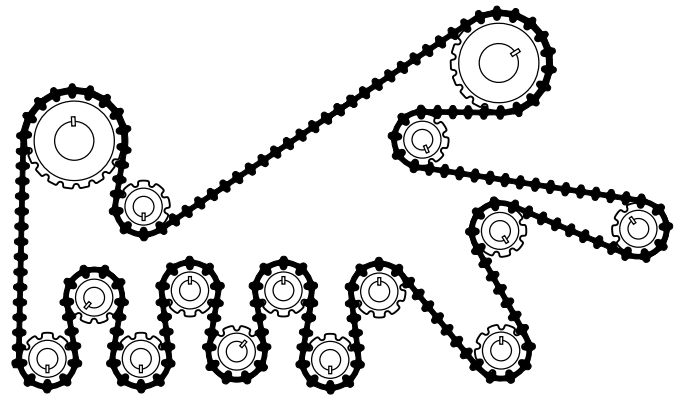
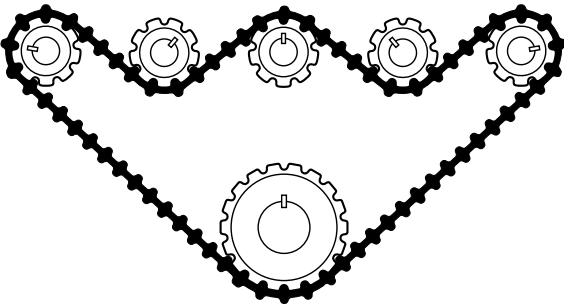
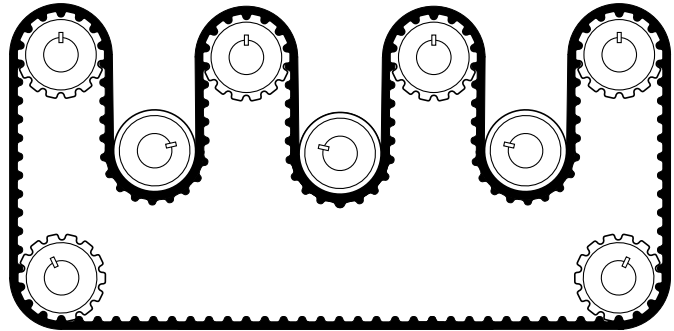
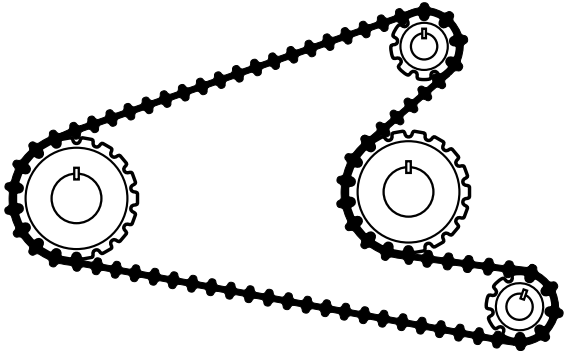

Conveying and Material Transport Applications

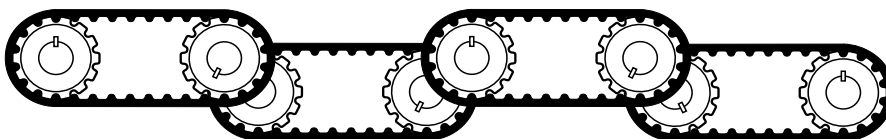
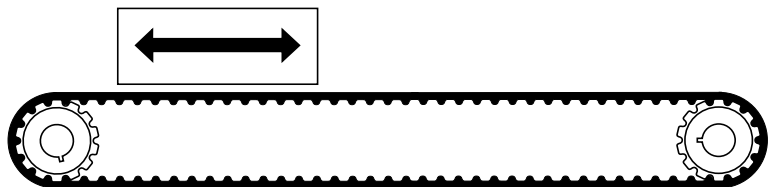
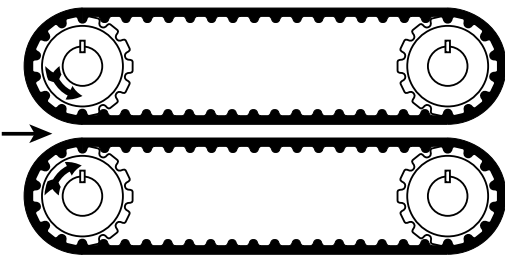

Rack and Carriage Drive Configurations

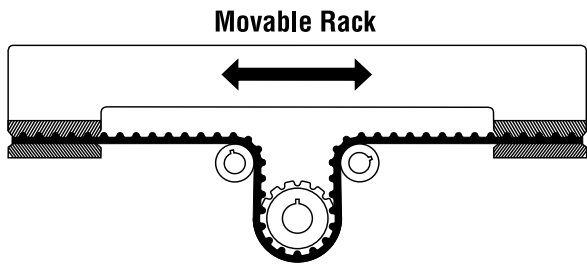
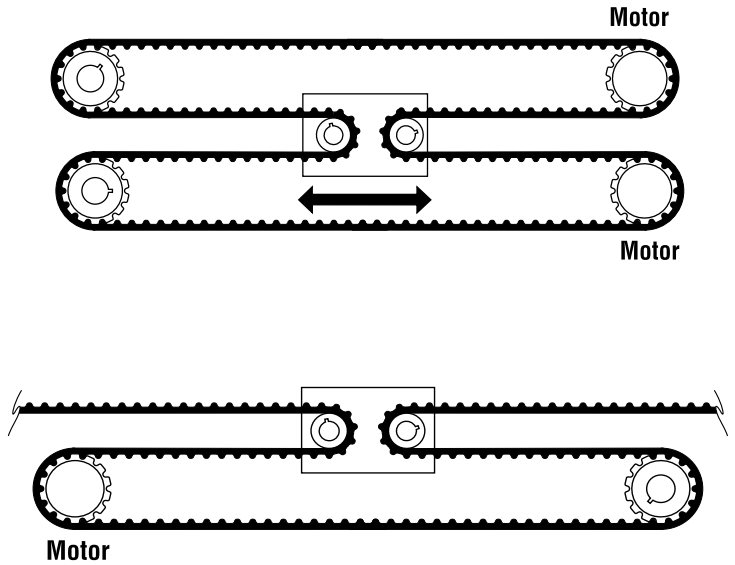
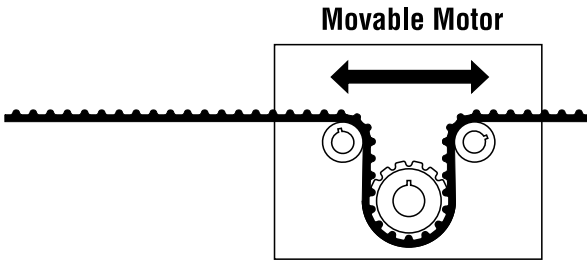

Long Length Drive Applications

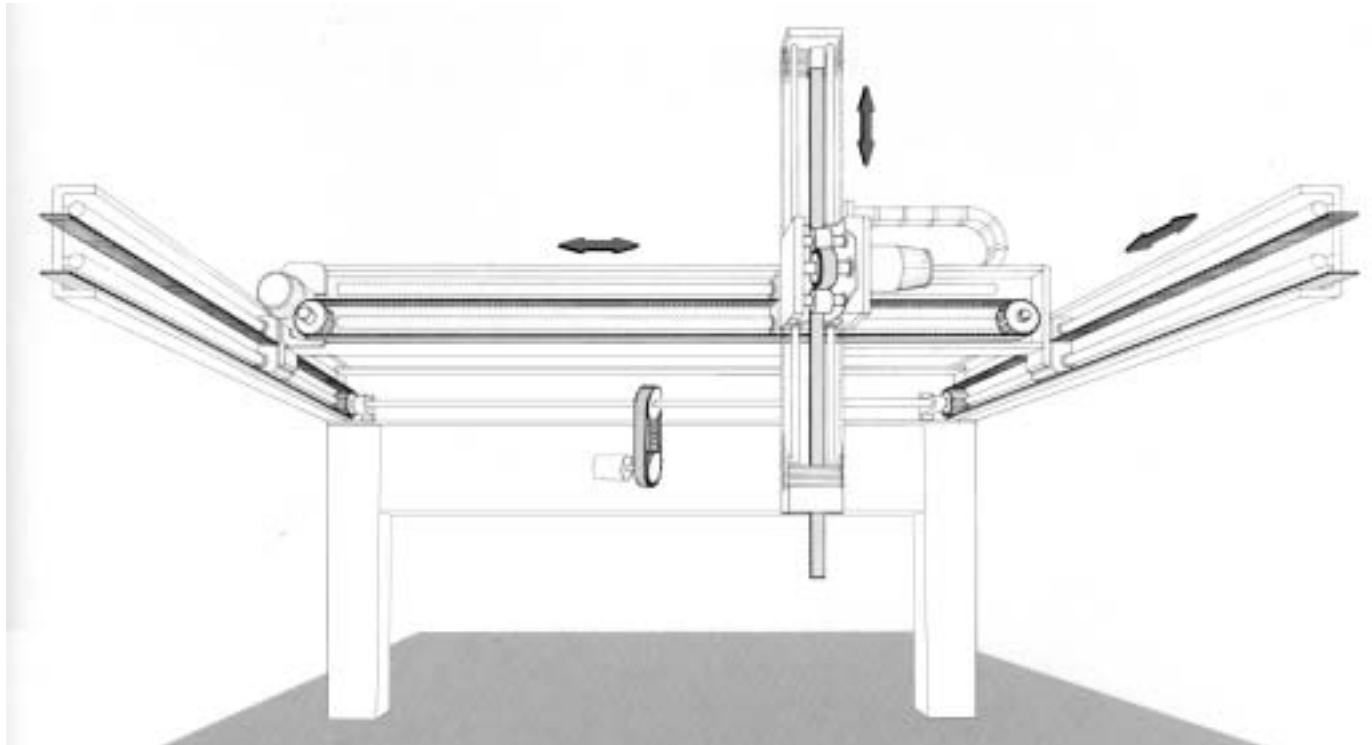

Complex Carriage Drive Configuration

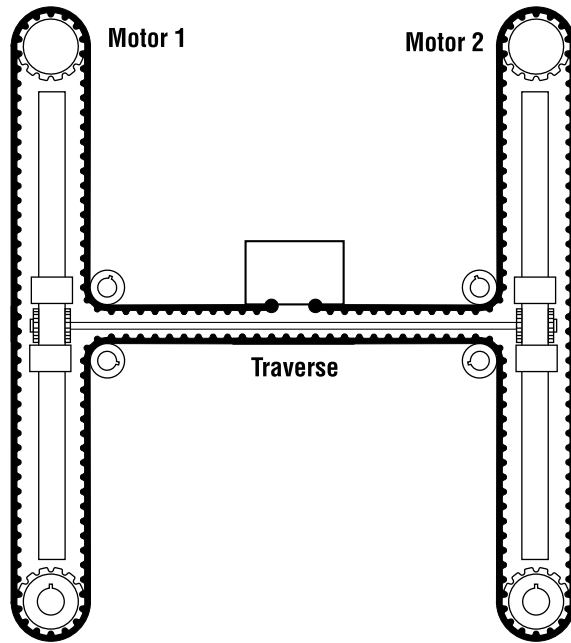

Lead Screw Drive Applications

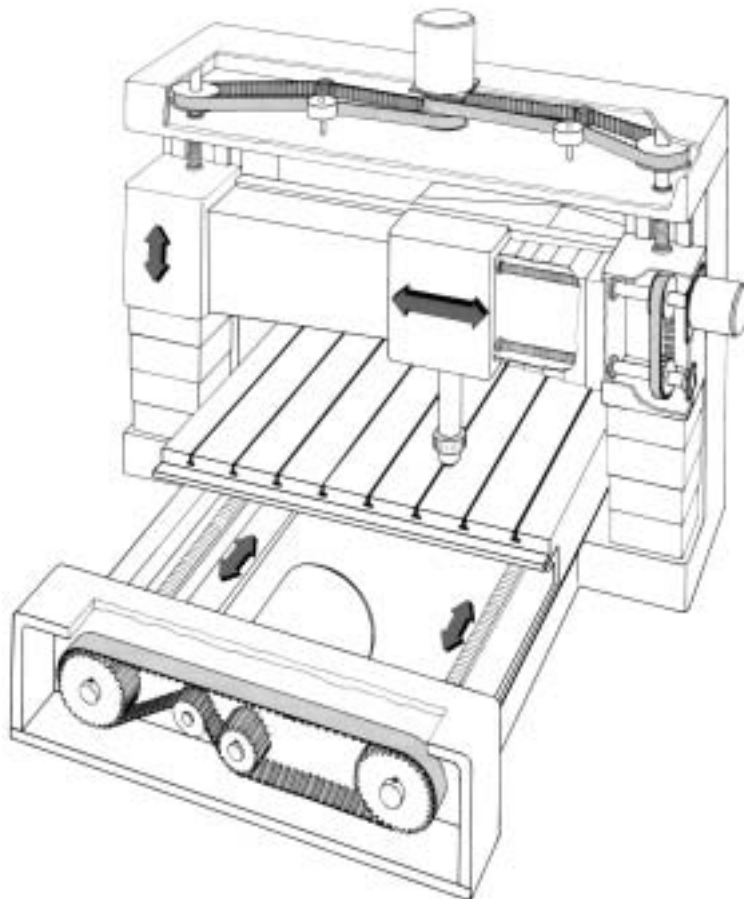

The Gates Rubber Company
990 South Broadway
P.O. Box 5887
Denver, CO 80217

For more information on any of Gates Industrial Power Transmission products, programs or services, contact your local Gates representative, call the Gates Belt Information Line at 800-777-6363, or visit us at www.gates.com.

Gates Canada, Inc.
300 Henry Street
Brantford, ON N3S 7R5
Telephone: 519-759-4141
Fax: 519-759-0944

Your Local Distributor

PowerGrip® GT®2 Belt Drive Design Manual

**#17195
March 2000**



THE DRIVING FORCE IN POWER TRANSMISSION

© 2000 The Gates Rubber Company
All rights reserved. Form 17195
Printed in the U.S.A.