

# Hi-eX

## Marginally lubricated

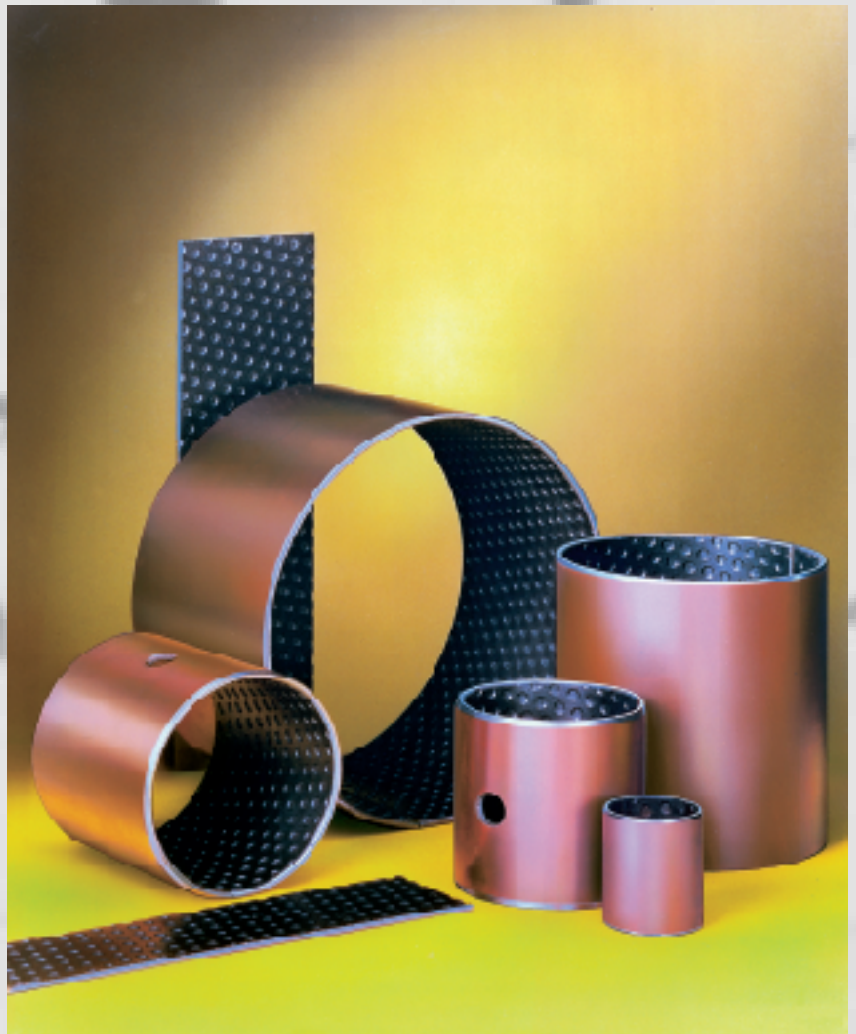

## Quality

All the products described in this handbook are manufactured under DIN ISO 9001/2 or QS 9000 approved quality management systems.



## Formula Symbols and Designations

Formula Symbol	Unit	Designation
$a_B$	-	Bearing size factor
$a_E$	-	High load factor
$a_Q$	-	Speed/Load factor
$a_S$	-	Surface finish factor
$a_T$	-	Temperature application factor
$B$	mm	Nominal bush width
$C$	1/min	Dynamic load frequency
$C_D$	mm	Installed diametral clearance
$C_{Dm}$	mm	Diametral clearance machined
$C_T$	-	Total number of dynamic load cycles
$C_i$	mm	ID chamfer length
$C_o$	mm	OD chamfer length
$D_H$	mm	Housing Diameter
$D_i$	mm	Nominal bush/thrust washer ID
$D_{i,a}$	mm	Bush ID when assembled in housing
$D_{i,a,m}$	mm	Bush ID assembled and machined
$D_J$	mm	Shaft diameter
$D_o$	mm	Nominal bush/thrust washer OD
$d_D$	mm	Dowel hole diameter
$d_L$	mm	Oil hole diameter
$d_P$	mm	Pitch circle diameter for dowel hole
$F$	N	Bearing load
$F_i$	N	Insertion force
$f$	-	friction
$L$	mm	Strip length
$L_H$	h	Bearing service life
$L_{RG}$	h	Relubrication interval
$N$	1/min	Rotational speed
$N_{osz}$	1/min	Oscillating movement frequency

Formula Symbol	Unit	Designation
$\bar{p}$	N/mm <sup>2</sup>	Specific load
$\bar{p}_{lim}$	N/mm <sup>2</sup>	Specific load limit
$\bar{p}_{sta,max}$	N/mm <sup>2</sup>	Maximum static load
$\bar{p}_{dyn,max}$	N/mm <sup>2</sup>	Maximum dynamic load
$Q$	-	Total number of cycles
$R$	-	Number of lubrication intervals
$R_a$	μm	Surface roughness (DIN 4768, ISO/DIN 4287/1)
$S_3$	mm	Bush wall thickness
$S_S$	mm	Strip thickness
$S_T$	mm	Thrust washer thickness
$T$	°C	Temperature
$T_a$	mm	Depth of Housing Recess
$T_{amb}$	°C	Ambient temperature
$T_{max}$	°C	Maximum temperature
$T_{min}$	°C	Minimum temperature
$U$	m/s	Sliding speed
$u$	-	speed factor
$W$	mm	Strip width
$W_u$	mm	Maximum usable strip width
$\alpha_1$	1/10 <sup>6</sup> K	Coefficient of linear thermal expansion parallel to surface
$\alpha_2$	1/10 <sup>6</sup> K	Coefficient of linear thermal expansion normal to surface
$\sigma_c$	N/mm <sup>2</sup>	Compressive Yield strength
$\lambda$	W/mK	Thermal conductivity
$\varphi$	°	Angular displacement
$\eta$	Ns/mm <sup>2</sup>	Dynamic Viscosity
$Z_T$	-	Total number of oscillating movements

## Content

Quality .....	I		
Formula Symbols and Designations .....	II		
<b>1 Introduction .....</b>	<b>4</b>		
<b>1.1 Characteristics and Advantages .....</b>	<b>4</b>		
<b>2 Structure .....</b>	<b>4</b>		
<b>2.1 Basic Forms .....</b>	<b>5</b>		
<b>3 Properties .....</b>	<b>6</b>		
<b>3.1 Physical Properties .....</b>	<b>6</b>		
<b>3.2 Chemical Properties .....</b>	<b>6</b>		
<b>4 Lubrication and Friction .</b>	<b>7</b>		
<b>4.1 Dry operation .....</b>	<b>7</b>		
<b>4.2 Choice of Lubricant .....</b>	<b>7</b>		
Grease .....	7		
Oil .....	7		
Non lubricating fluids .....	7		
<b>4.3 Friction .....</b>	<b>9</b>		
<b>4.4 Lubricated Environments .....</b>	<b>9</b>		
Lubrication .....	9		
<b>4.5 Characteristics of Fluid Lubricated Hi-eX Bearings .....</b>	<b>10</b>		
<b>4.6 Design Guidance for Fluid Lubricated Applications</b>	<b>10</b>		
<b>4.7 Wear Rate and Re-lubrication Intervals with Grease lubrication .....</b>	<b>12</b>		
Fretting Wear .....	12		
<b>5 Design Factors .....</b>	<b>13</b>		
<b>5.1 Specific Load .....</b>	<b>13</b>		
Specific Load Limit .....	13		
<b>5.2 Sliding Speed .....</b>	<b>14</b>		
Continuous Rotation .....	14		
Oscillating Movement .....	14		
<b>5.3 pU Factor .....</b>	<b>15</b>		
<b>5.4 Load .....</b>	<b>15</b>		
Type of Load .....	15		
<b>5.5 Temperature .....</b>	<b>17</b>		
<b>5.6 Mating Surface .....</b>	<b>17</b>		
<b>5.7 Bearing Size .....</b>	<b>18</b>		
<b>5.8 Estimation of Bearing Service Life with Grease Lubrication .....</b>	<b>18</b>		
Calculation Parameters .....	18		
Estimate Bearing Life .....	19		
Estimate Re-greasing Interval ..	19		
Oscillating Motion and Dynamic Loads .....	19		
<b>5.9 Worked Examples .....</b>	<b>20</b>		
<b>6.1 Data for bearing design calculations .....</b>	<b>21</b>		
<b>7.1 Dimensions and Tolerances ..</b>	<b>22</b>		
<b>7.2 Tolerances for minimum clearance .....</b>	<b>22</b>		
Grease lubrication .....	22		
Fluid Lubrication .....	24		
Allowance for Thermal Expansion .....	24		
<b>7.3 Counterface Design .....</b>	<b>25</b>		
<b>7.4 Installation .....</b>	<b>26</b>		
Fitting of Bushes .....	26		
Insertion Forces .....	26		
Alignment .....	27		
Sealing .....	27		
Axial Location .....	27		
Fitting of Thrust Washers .....	27		
Slideways .....	28		
<b>8 Machining .....</b>	<b>29</b>		
<b>8.1 Machining Practice .....</b>	<b>29</b>		
<b>8.2 Boring .....</b>	<b>29</b>		
<b>8.3 Reaming .....</b>	<b>30</b>		
<b>8.4 Broaching .....</b>	<b>30</b>		
<b>8.5 Vibrobroaching .....</b>	<b>31</b>		
<b>8.6 Modification of components ..</b>	<b>31</b>		
<b>8.7 Drilling Oil Holes .....</b>	<b>31</b>		
<b>8.8 Cutting Strip Material .....</b>	<b>31</b>		
<b>9 Electroplating .....</b>	<b>32</b>		
Hi-eX Components .....	32		
Mating Surfaces .....	32		
<b>10 Standard Products ....</b>	<b>33</b>		
<b>10.1 PM-HX cylindrical bushes ....</b>	<b>33</b>		
<b>10.2 MB-HX cylindrical bushes ....</b>	<b>40</b>		
<b>10.3 HX Thrust Washers .....</b>	<b>45</b>		
<b>10.4 HX Strip .....</b>	<b>46</b>		

**1 Introduction**

# 1 Introduction

The purpose of this handbook is to provide comprehensive technical information on the characteristics of Hi-eX™ bearings. The information given, permits designers to establish the correct size of bearing required and the expected life and performance. Glacier Garlock Bearings Research and Development services are available to assist with unusual design problems.

Complete information on the range of Hi-eX standard products is given together with details of other Hi-eX products.

Glacier Garlock Bearings is continually refining and extending its experimental and theoretical knowledge and, therefore, when using this brochure it is always worthwhile to contact the Company should additional information be required.

Customers are advised to carry out prototype testing wherever possible.

## 1.1 Characteristics and Advantages

- **Hi-eX provides maintenance free operation**
- **Hi-eX has a high pU capability**
- **Hi-eX exhibits low wear rate**
- **Seizure resistant**
- **Suitable for temperatures from -150 °C to +250 °C**
- **High static and dynamic load capacity**
- **Hi-eX polymer bearing lining has good chemical resistance**
- **No water absorption and therefore dimensionally stable**
- **Compact and light**
- **Suitable for rotating, oscillating, reciprocating and sliding movements**
- **Hi-eX bearings are prefinished and require no machining after assembly**
- **Suitable for use with low viscosity and low lubricant fluids.**

## 2 Structure

Hi-eX is a composite bearing material developed specifically to operate with marginal lubrication and consists of three bonded layers: a steel backing strip and a sintered porous bronze matrix, impregnated and overlaid with a PEEK (polyether ether ketone) polymer bearing material, containing fillers including PTFE (polytetrafluorethylene).

The steel backing provides mechanical strength and the bronze interlayer provides a strong mechanical bond for the lining. This construction promotes dimensional stability and improves thermal conductivity, thus reducing the temperature at the bearing surface.

For grease lubricated applications Hi-eX is manufactured with a polymer overlay thickness above the bronze sinter layer of 0.30 mm nominal, and the bearing surface is provided with a uniform pattern of indents. These serve as a reservoir for the grease

and are designed to provide the optimum distribution of the lubricant over the bearing surface (e.g. PM2020HX).

For fluid lubricated applications where the bearing surface may be required to be machined subsequent to assembly, Hi-eX is manufactured with a polymer overlay thickness above the bronze sinter layer of 0.30 mm nominal, and the indent pattern omitted from the bearing surface (e.g. PM2020 HX (U)).

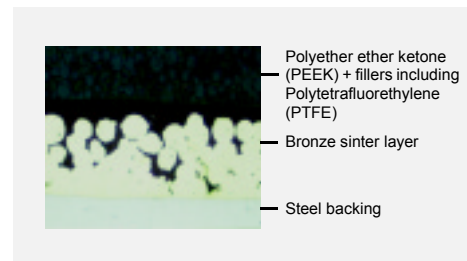

Fig. 1: Hi-eX-microsection



## 2.1 Basic Forms

Hi-eX is **not** available from stock and is manufactured only to order as follows:

### Standard Components

These products are manufactured to International, National or Glacier Garlock Bearings standard designs.

- Cylindrical Bushes
  - **PM** pre finished **metric** range, not machinable in situ, for use with stan-

dard journals finished to h6-h8 limits.

- **MB** machinable **metric** range, with an allowance for machining in situ.

- Thrust Washers
- Strip Material



Fig. 2: Standard components

### Non Standard Components

These products are manufactured to customers' requirements with or without Glacier Garlock Bearings recommendations, and include for example

- Modified Standard Components

- Half Bearings
- Flat Components
- Pressings
- Stampings



Fig. 3: Non standard components

3 Properties

### 3 Properties

#### 3.1 Physical Properties

	Characteristic	Symbol	Value Hi-eX	Unit	Comments
<b>Physical Properties</b>	Thermal Conductivity	$\lambda$	52	W/mK	
	Coefficient of linear thermal expansion :				
	parallel to surface	$\alpha_1$	11	1/10 <sup>6</sup> K	
	normal to surface	$\alpha_2$	29	1/10 <sup>6</sup> K	
	Maximum Operating Temperature	$T_{max}$	250	°C	
	Minimum Operating Temperature	$T_{min}$	-150	°C	
<b>Mechanical Properties</b>	Compressive Yield Strength	$\sigma_c$	380	N/mm <sup>2</sup>	measured on disc 5 mm diameter x 2.45 mm thick.
	Maximum Load				
	Static	$\bar{p}_{sta,max}$	140	N/mm <sup>2</sup>	
	Dynamic	$\bar{p}_{dyn,max}$	140	N/mm <sup>2</sup>	
<b>Electrical Properties</b>	Volume resistivity of PEEK lining		>10 <sup>9</sup>	Ω cm	

Table 1: Physical, mechanical and electrical properties of Hi-eX

#### 3.2 Chemical Properties

The following table provides an indication of the resistance of Hi-eX to various chemical media. It is recommended that the chemical resistance is confirmed by testing if possible.

+	<b>Satisfactory:</b> Corrosion damage is unlikely to occur.
o	<b>Acceptable:</b> Some corrosion damage may occur but this will not be sufficient to impair either the structural integrity or the tribological performance of the material.
-	<b>Unsatisfactory:</b> Corrosion damage will occur and is likely to affect either the structural integrity and/or the tribological performance of the material.

	Chemical	%	°C	Rating
<b>Strong Acids</b>	Hydrochloric Acid	5	20	-
	Nitric Acid	5	20	-
	Sulphuric Acid	5	20	-
<b>Weak Acids</b>	Acetic Acid	5	20	-
	Formic Acid	5	20	-
<b>Bases</b>	Ammonia	10	20	o
	Sodium Hydroxide	5	20	o
<b>Solvents</b>	Acetone		20	+
	Carbon Tetrachloride		20	+
<b>Lubricants and fuels</b>	Paraffin		20	+
	Gasolene		20	+
	Kerosene		20	+
	Diesel fuel		20	+
	Mineral Oil		70	+
	HFA-ISO46 High Water fluid		70	+
	HFC-Water-Glycol		70	+
	HFD-Phosphate Ester		70	+
	Water		20	o
	Sea Water		20	-

Table 2: Chemical resistance of Hi-eX

## 4 Lubrication and Friction

### 4.1 Dry operation

Hi-eX will operate satisfactorily without lubrication under light duty running conditions at  $\bar{p}U$  factors below  $0.01 \text{ N/mm}^2 \times \text{m/s}$  and

sliding speeds below 2.5 m/s. The wear performance should be confirmed by testing if possible.

### 4.2 Choice of Lubricant

Hi-eX will generally be lubricated, the choice of lubricant depending upon:

- $\bar{p}U$  and sliding speed
- the stability of the lubricant under the operating conditions.

#### Grease

The performance ratings of different types of grease are indicated in Table 3. Greases containing EP additives or significant additions of graphite or  $\text{MoS}_2$  are not generally recommended for use with Hi-eX.

Hi-eX is able to withstand environmental temperatures beyond those generally suitable for grease lubrication and the performance is therefore likely to be limited by

the lubricant and not by the bearing material. For environmental temperatures above  $80^\circ\text{C}$  suitability of the grease should be established by test and a silicone oil base or high temperature grease is recommended. For applications above  $150^\circ\text{C}$   $\bar{p}U$  values should be limited to below  $1.0 \text{ N/mm}^2 \times \text{m/s}$  and re-lubrication intervals should not exceed 500 hours.

#### Oil

Hi-eX is recommended for use with oil lubrication. Hi-eX is compatible with mineral oils up to  $150^\circ\text{C}$  and is resistant to the oxidation products which may occur with mineral oils at temperatures above  $115^\circ\text{C}$ .

Degradation of oils is likely to occur following extended exposure to high temperatures and synthetic lubricants are recommended under these circumstances.

#### Non lubricating fluids

Hi-eX has been found to perform satisfactorily with low viscosity and non lubricating fluids such as polyethylene glycol and polyglycol lubricants, water-oil emulsion, shock-absorber oils, kerosene and water.

In general, the fluid will be acceptable if it does not chemically attack the PEEK lining or the porous bronze interlayer. Chemical resistance data are given in Table 2.

Where there is doubt about the suitability of a fluid, a simple test is to submerge a

sample of Hi-eX material in the fluid for two to three weeks at  $15\text{-}20^\circ\text{C}$  above the operating temperature. The following will usually indicate that the fluid is not suitable for use with Hi-eX.

- A significant change in the thickness of the Hi-eX material,
- A visible change in the bearing surface from polished to matt.
- A visible change in the microstructure of the bronze interlayer



## 4 Lubrication and Friction

<b>+</b>	<b>Recommended</b>
<b>o</b>	<b>Satisfactory</b>
<b>-</b>	<b>Not recommended</b>
<b>NA</b>	<b>Data not available</b>

Manufacturer	Grade	Type		Rating
		Oil	Thickener	
<b>BP</b>	Energrease LS2	Mineral	Lithium Soap	<b>+</b>
	Energrease LT2	Mineral	Lithium Soap	<b>+</b>
	Energrease FGL	Mineral	Non Soap	<b>o</b>
	Energrease GSF	Synthetic	NA	<b>o</b>
<b>Century</b>	Lacerta ASD	Mineral	Lithium/Polymer	<b>o</b>
	Lacerta CL2X	Mineral	Calcium	<b>-</b>
<b>Dow Corning</b>	Molykote 55M	Silicone	Lithium Soap	<b>o</b>
	Molykote PG65	PAO	Lithium Soap	<b>+</b>
	Molykote PG75	Synthetic/Mineral	Lithium Soap	<b>o</b>
	Molykote PG602	Mineral	Lithium Soap	<b>o</b>
<b>Elf</b>	Rolexa.1	Mineral	Lithium Soap	<b>+</b>
	Rolexa.2	Mineral	Lithium Soap	<b>o</b>
	Epexelf.2	Mineral	Lithium/Calcium Soap	<b>-</b>
<b>Esso</b>	Andok C	Mineral	Sodium Soap	<b>o</b>
	Andok 260	Mineral	Sodium Soap	<b>o</b>
	Cazar K	Mineral	Calcium Soap	<b>-</b>
<b>Mobil</b>	Mobilplex 47	Mineral	Calcium Soap	<b>-</b>
	Mobiltemp 1	Mineral	Non Soap	<b>o</b>
<b>Rocol</b>	BG622	White Mineral	Calcium Soap	<b>o</b>
	Sapphire	Mineral	Lithium Complex	<b>-</b>
	White Food Grease	White Oil	Clay	<b>-</b>
<b>Shell</b>	Albida R2	Mineral	Lithium Complex	<b>+</b>
	Axinus S2	Mineral	Lithium	<b>o</b>
	Darina R2	Mineral	Inorganic Non Soap	<b>+</b>
	Stamina U2	Mineral	Polyurea	<b>-</b>
	Tivela A	Synthetic	NA	<b>o</b>
<b>Total</b>	Aerogrease	Synthetic	NA	<b>+</b>
	Multis EP2	NA	Lithium	<b>+</b>

Table 3: Performance of greases

### 4.3 Friction

The coefficient of friction of lubricated Hi-eX depends upon the actual operating conditions as indicated in section 4.4.

Where frictional characteristics are critical to a design they should be established by prototype testing.

### 4.4 Lubricated Environments

The following sections describe the basics of lubrication and provide guidance on the

application of Hi-eX in such environments.

#### Lubrication

There are three modes of lubricated bearing operation which relate to the thickness of the developed lubricant film between the bearing and the mating surface.

These three modes of operation depend upon:

- Bearing dimensions
- Clearance
- Load and Speed
- Lubricant Viscosity and Flow

#### Hydrodynamic lubrication

Characterised by:

- Complete separation of the shaft from the bearing by the lubricant film
- Very low friction and no wear of the bearing or shaft since there is no contact
- Coefficients of friction of 0.001 to 0.01

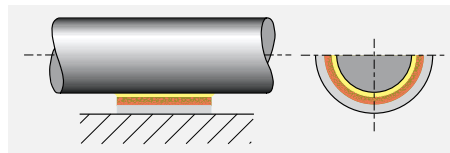

Fig. 4: Hydrodynamic lubrication

Hydrodynamic conditions occur when

$$(4.4.1) \quad \bar{p} \leq \frac{U \cdot \eta}{7.5} \cdot \frac{B}{D_i} \quad [\text{N/mm}^2]$$

#### Mixed film lubrication

Characterised by:

- Combination of hydrodynamic and boundary lubrication.
- Part of the load is carried by localised areas of self pressurised lubricant and the remainder supported by boundary lubrication.
- Friction and wear depend upon the degree of hydrodynamic support developed.
- Hi-eX provides low friction and high wear resistance to support the boundary lubricated element of the load.

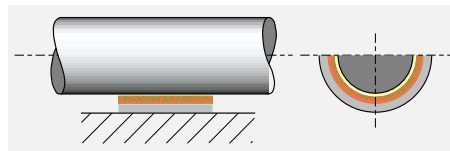

Fig. 5: Mixed film lubrication

## 4 Lubrication and Friction

### Boundary lubrication

Characterised by:

- Rubbing of the shaft against the bearing with virtually no lubricant separating the two surfaces.
- Bearing material selection is critical to performance.
- Shaft wear is likely due to contact between bearing and shaft.
- The excellent properties of Hi-eX material minimises wear under these conditions.
- The dynamic coefficient of friction with Hi-eX is typically 0.02 to 0.15 under boundary lubrication conditions.

- The static coefficient of friction with Hi-eX is typically 0.05 to 0.20 under boundary lubrication conditions.

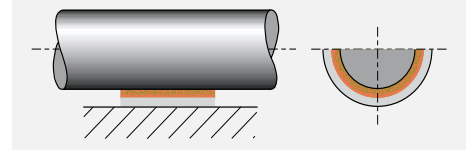

Fig. 6: Boundary lubrication

### 4.5 Characteristics of Fluid Lubricated Hi-eX Bearings

Hi-eX is particularly effective in the most demanding of lubricated applications

where full hydrodynamic operation cannot be maintained, for example:

- **High load conditions**  
In highly loaded applications operating under boundary or mixed film conditions Hi-eX shows excellent wear resistance.
- **Start up and shut down under load**  
With insufficient speed to generate a hydrodynamic film the bearing will operate under boundary or mixed film conditions.
  - Hi-eX minimises wear

- **Sparse lubrication**  
Many applications require the bearing to operate with less than the ideal lubricant supply, typically with splash or mist lubrication only.  
The PEEK lining of Hi-eX has low thermal conductivity relative to conventional metallic bearings, and therefore depending upon the operating conditions may require a greater lubricant supply to remove the generated heat in the bearing.
  - Hi-eX shows greater wear resistance than conventional metallic bearings.

### 4.6 Design Guidance for Fluid Lubricated Applications

Fig. 7, Page 11 shows the three lubrication regimes discussed above plotted on a

graph of sliding speed vs the ratio of specific load to lubricant viscosity.

#### In order to use Fig. 7

- Using the formulae in Section 5
  - Calculate the specific load  $\bar{p}$
  - Calculate the shaft surface speed  $U$

- Using the viscosity temperature relationships presented in Table 4.
  - Determine the viscosity in centipoise of the lubricant.

#### Note:

Viscosity is a function of operating temperature. If the operating temperature of the fluid is unknown, a provisional temperature of 25 °C above ambient can be used.

## Area 1 of Fig. 7

The bearing will operate with boundary lubrication.

The  $\bar{p}U$  factor will be the major determinant of bearing life.

If  $e\bar{p}U/\eta \leq 0.2$  then

$$(4.6.1) \quad L_H = \frac{2250}{\left(\frac{e\bar{p}U}{\eta}\right)^{0.5}} \cdot a_Q \cdot a_T \cdot a_S \quad [h]$$

If  $0.2 < e\bar{p}U/\eta \leq 1.0$  then

$$(4.6.2) \quad L_H = \frac{1000}{\left(\frac{e\bar{p}U}{\eta}\right)} \cdot a_Q \cdot a_T \cdot a_S \quad [h]$$

## Area 2 of Fig. 7

The bearing will operate with mixed film lubrication.

$\bar{p}U$  factor is no longer a significant parameter in determining the bearing life.

## Area 3 of Fig. 7

The bearing will operate with hydrodynamic lubrication. Bearing wear will be determined only by the cleanliness of the

## Area 4 of Fig. 7

- These are the most demanding operating conditions.
- The bearing is operated under either high speed or high bearing load to viscosity ratio, or a combination of both.
- These conditions may cause

Hi-eX bearing performance can be estimated from the following:

Calculate Effective  $\bar{p}U$  Factor from Section 5.8.

If  $e\bar{p}U/\eta > 1.0$  then

$$(4.6.3) \quad L_H = \frac{1000}{\left(\frac{e\bar{p}U}{\eta}\right)^2} \cdot a_Q \cdot a_T \cdot a_S \quad [h]$$

Hi-eX bearing performance will depend upon the nature of the fluid and the actual service conditions.

lubricant and the frequency of start up and shut down.

- excessive operating temperature
- and/or high wear rate.
- Bearing performance may be improved:
  - by use of unindented Hi-eX lining
  - by the addition of one or more grooves to the bearing
  - by shaft surface finish  $< 0.05 \mu\text{m } R_a$ .

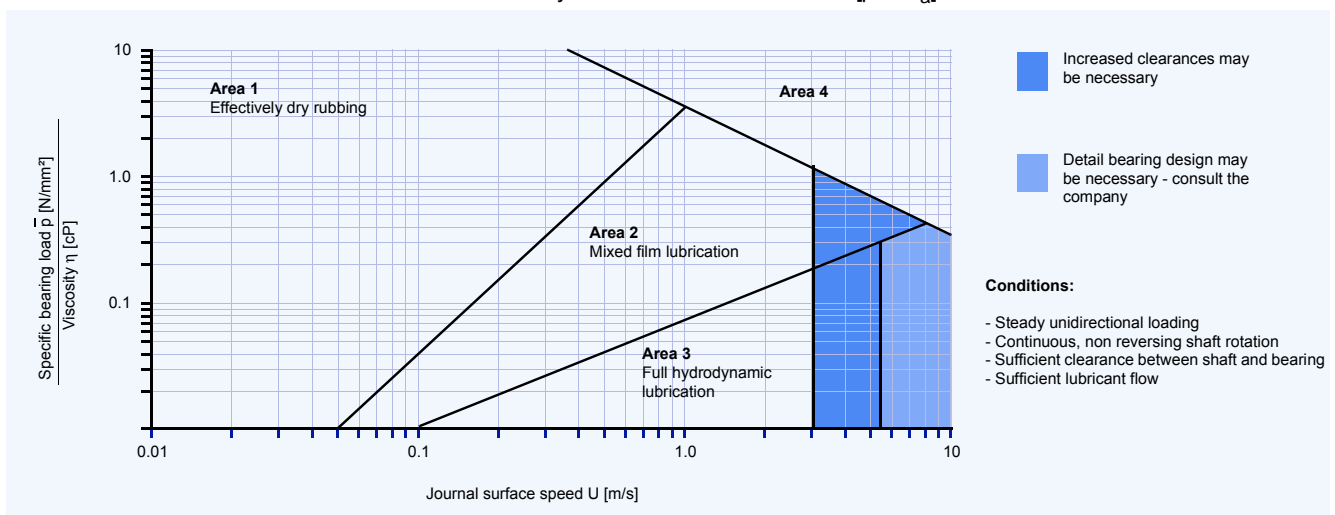

Fig. 7: Design guide for lubricated application

# 4 Lubrication and Friction

Temperature [°C]	cP														
	0	10	20	30	40	50	60	70	80	90	100	110	120	130	140
<b>Lubricant</b>															
<b>ISO VG 32</b>	310	146	77	44	27	18	13	9.3	7.0	5.5	4.4	3.6	3.0	2.5	2.2
<b>ISO VG 46</b>	570	247	121	67	40	25	17	12	9.0	6.9	5.4	4.4	3.6	3.0	2.6
<b>ISO VG 68</b>	940	395	190	102	59	37	24	17	12	9.3	7.2	5.8	4.7	3.9	3.3
<b>ISO VG 100</b>	2110	780	335	164	89	52	33	22	15	11.3	8.6	6.7	5.3	4.3	3.6
<b>ISO VG 150</b>	3600	1290	540	255	134	77	48	31	21	15	11	8.8	7.0	5.6	4.6
<b>Diesel oil</b>	4.6	4.0	3.4	3.0	2.6	2.3	2.0	1.7	1.4	1.1	0.95				
<b>Petrol</b>	0.6	0.56	0.52	0.48	0.44	0.40	0.36	0.33	0.31						
<b>Kerosene</b>	2.0	1.7	1.5	1.3	1.1	0.95	0.85	0.75	0.65	0.60	0.55				
<b>Water</b>	1.79	1.30	1.0	0.84	0.69	0.55	0.48	0.41	0.34	0.32	0.28				

Table 4: Viscosity data

## 4.7 Wear Rate and Re-lubrication Intervals with Grease lubrication

At specific bearing loads below 100 N/mm<sup>2</sup> a grease lubricated Hi-eX bearing shows only small bedding-in wear of about 0.0025 mm. This is followed by little wear during the early part of the bearing life until the lubricant becomes exhausted and the wear rate increases. If the bearing is regreased before the rate of wear starts to increase rapidly the material will continue to function satisfactorily with little wear. Fig. 8 shows the typical wear pattern.

Under specific loads above 100 N/mm<sup>2</sup> the initial bedding-in wear is greater, typically about 0.025 mm, followed by a decreasing wear rate until the bearing exhibits a similar wear/life relationship to that shown in Fig. 8.

The useful life of the bearing is limited by wear in the loaded area. If this wear exceeds 0.15mm the grease capacity of the indents is reduced and more frequent regreasing of the bearing will be required.

### Fretting Wear

Oscillating movements of less than the dimensions of the indent pattern may cause localised wear of the mating surface after prolonged usage. This will result in the indent pattern becoming transferred

onto the mating surface in contact with the Hi-eX bearing and may also give rise to fretting corrosion damage. In this situation DS<sup>TM</sup> material should be considered as an alternative to Hi-eX.

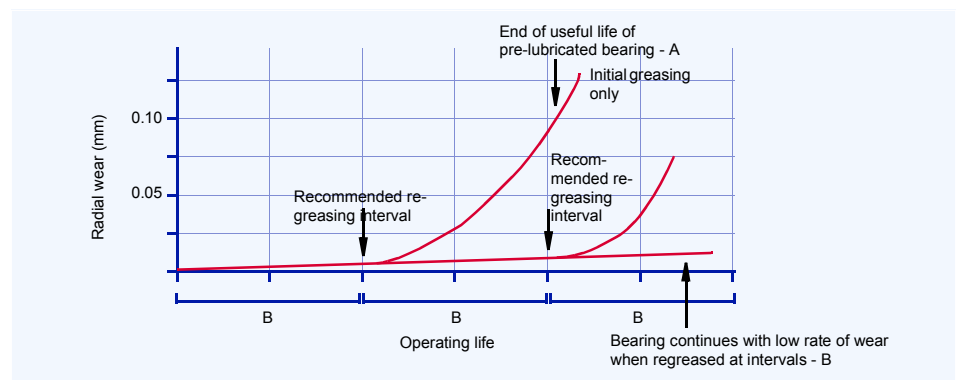

Fig. 8: Typical wear of Hi-eX

## 5 Design Factors

The main parameters when determining the size or calculating the service life for a Hi-eX bearing are:

- Specific Load Limit  $\bar{p}_{lim}$  [N/mm<sup>2</sup>]
- $\bar{p}U$  Factor [N/mm<sup>2</sup> x m/s]
- Mating surface roughness  $R_a$  [ $\mu\text{m}$ ]
- Mating surface material
- Temperature  $T$  [ $^{\circ}\text{C}$ ]
- Other environmental factors eg. housing design, dirt, lubrication.

### 5.1 Specific Load

The specific load  $\bar{p}$  is defined as the working load divided by the projected area of

the bearing and is expressed in N/mm<sup>2</sup>.

#### Bushes

$$(5.1.1) \quad \bar{p} = \frac{F}{D_i \cdot B} \quad [\text{N/mm}^2]$$

#### Slide Plates

$$(5.1.3) \quad \bar{p} = \frac{F}{L \cdot W} \quad [\text{N/mm}^2]$$

#### Thrust Washers

$$(5.1.2) \quad \bar{p} = \frac{4F}{\pi \cdot (D_o^2 - D_i^2)} \quad [\text{N/mm}^2]$$

### Specific Load Limit

The maximum load which can be applied to a Hi-eX bearing can be expressed in terms of the Specific Load Limit, which depends on the type of the loading and lubrication. It is highest under steady loads. Conditions of dynamic load or oscillating movement which produce fatigue stress in the bearing result in a reduction in the specific load limit. The values of Specific Load Limit specified in Table 5 assume good alignment between the bearing and mating surface.

The Specific Load Limit for Hi-eX reduces for bearing operating temperatures in excess of 70  $^{\circ}\text{C}$ , falling to about half the values given in Table 5 for temperatures above 150  $^{\circ}\text{C}$ .

Conditions of dynamic load or oscillating movement which produce fatigue stress in the bearing result in a reduction in the permissible Specific Load Limit (Fig. 9, Page 14).

Load	Operating condition	Lubrication	$\bar{p}_{lim}$
Steady	Intermittent or very slow (below 0.01 m/s) continuous rotation or oscillating motion	Grease or oil	140
Steady	Continuous rotation or oscillating motion	Grease or oil (boundary lubrication)	90
Steady or dynamic	Continuous rotation or oscillating motion	Oil (hydrodynamic lubrication)	60

Table 5: Specific load limit  $\bar{p}_{lim}$  for Hi-eX



5 Design Factors

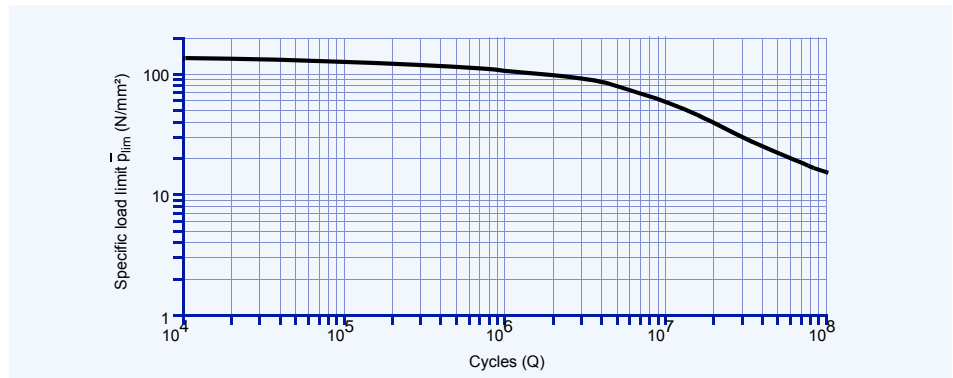

Fig. 9: Hi-eX specific load limits  $\bar{p}_{lim}$  under dynamic loads or oscillating conditions

5.2 Sliding Speed

The sliding speed U [m/s] is calculated as follows:

Continuous Rotation

Bushes

$$(5.2.1) \quad U = \frac{D_i \cdot \pi \cdot N}{60 \cdot 10^3} \quad [\text{N/mm}^2]$$

Thrust Washers

$$(5.2.2) \quad U = \frac{D_o + D_i}{2} \cdot \pi \cdot N \quad [\text{N/mm}^2]$$

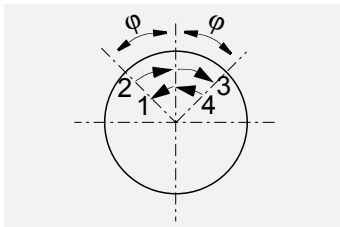

Fig. 10: Oscillating cycle  $\phi$

Oscillating Movement

Bushes

$$(5.2.3) \quad U = \frac{D_i \cdot \pi}{60 \cdot 10^3} \cdot \frac{4\phi \cdot N_{osz}}{360} \quad [\text{N/mm}^2]$$

Thrust Washers

$$(5.2.4) \quad U = \frac{D_o + D_i}{2} \cdot \pi \cdot \frac{4\phi \cdot N_{osz}}{360} \quad [\text{N/mm}^2]$$

The maximum permissible effective  $\bar{p}U$  factor ( $e\bar{p}U$  factor) for grease lubricated Hi-eX bearings is dependent upon the sliding

speed as shown in Fig. 11. For sliding speeds in excess of 2.5 m/s continuous oil lubrication is recommended.

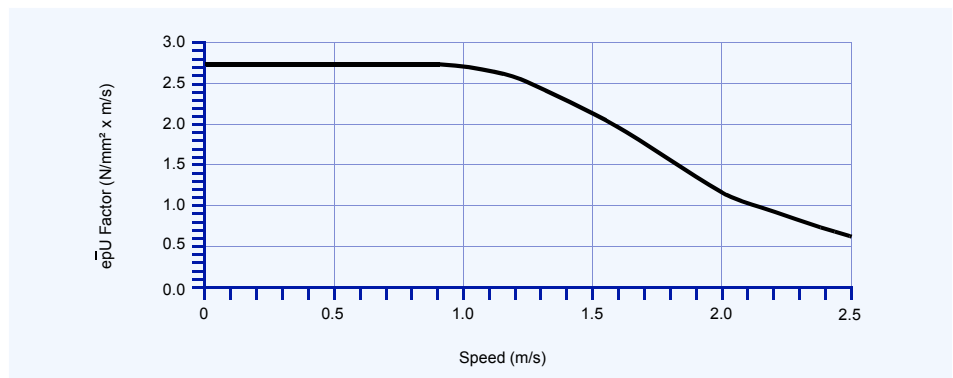

Fig. 11: Maximum  $e\bar{p}U$  factor for grease lubrication

### 5.3 $\bar{p}U$ Factor

The useful operating life of a Hi-eX bearing is governed by the  $\bar{p}U$  factor, which is calculated as follows:

$$(5.3.1)1 \quad \bar{p}U = \bar{p} \cdot U \quad [N/mm^2 \times m/s]$$

### 5.4 Load

In addition to its contribution to the  $\bar{p}U$  factor the type and direction of the applied load also affects the performance of a Hi-eX bearing. This is accommodated in the

calculation of the bearing service life by the speed/load application factor  $a_Q$  shown in Figs. 15-17.

#### Type of Load

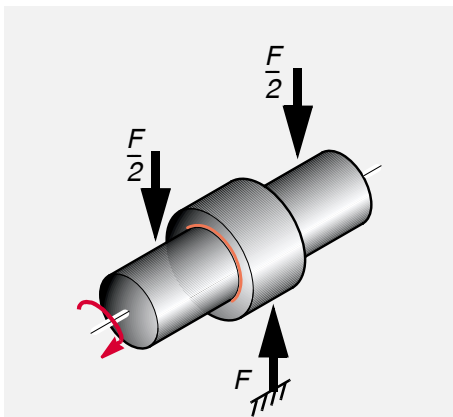

Fig. 12: Steady load, vertically downwards, bush stationary, shaft rotating. Lubricant drains to loaded area

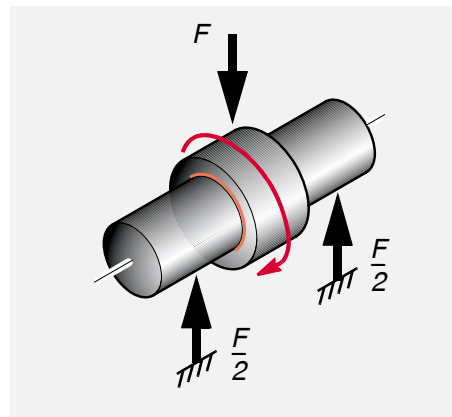

Fig. 14: Rotating load, shaft stationary, bush rotating

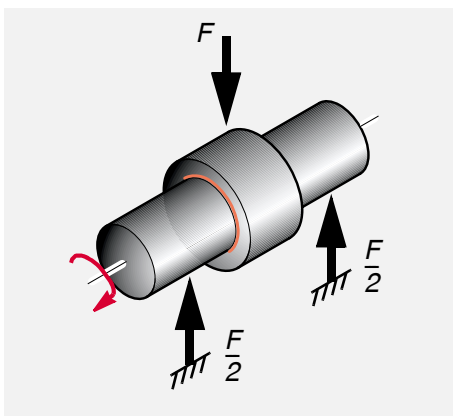

Fig. 13: Steady load, vertically upwards, bush stationary, shaft rotating. Lubricant drains away from loaded area

5 Design Factors

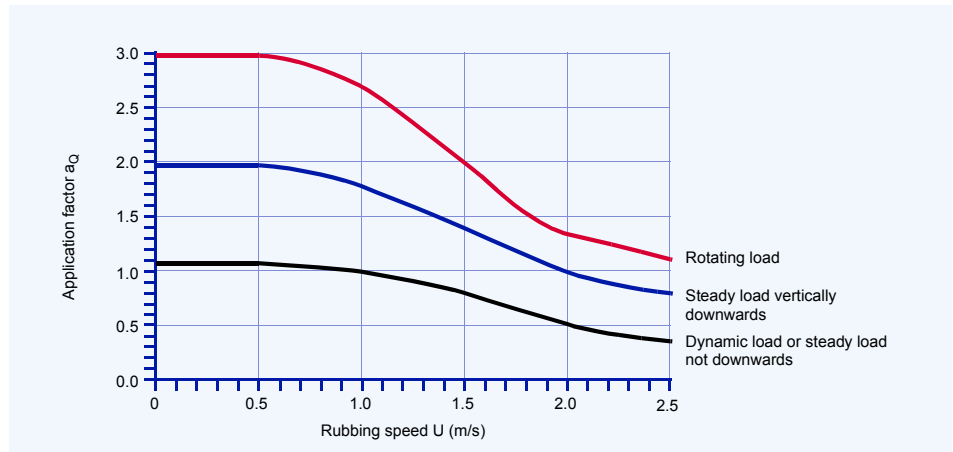

Fig. 15: Application factor  $a_Q$  for MB range bushes - unmachined

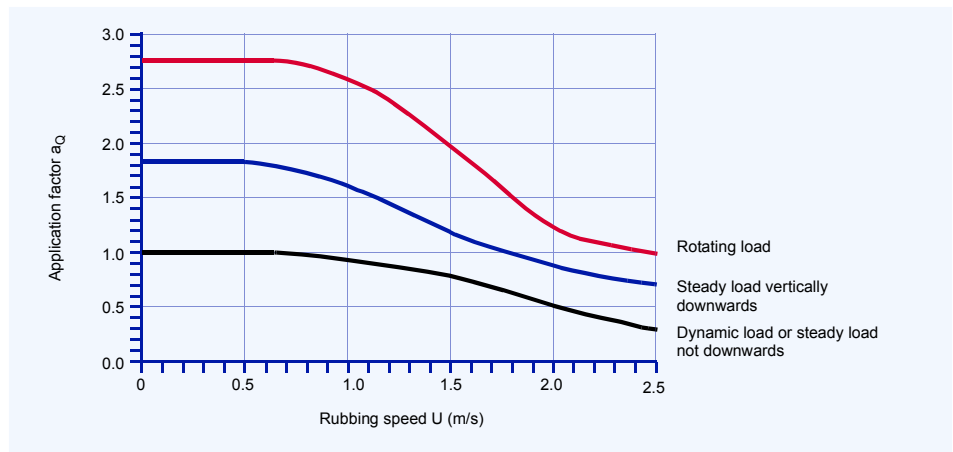

Fig. 16: Application factor  $a_Q$  for PM range and MB range bushes - machined

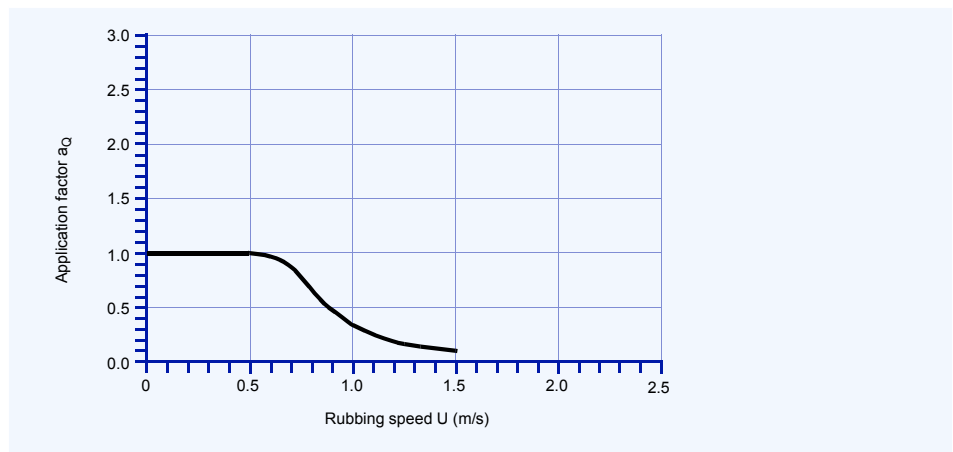

Fig. 17: Application factor  $a_Q$  for thrust washers

**Note:  $a_Q = 1$  for slideways**

### 5.5 Temperature

The useful life of a Hi-eX bearing depends upon the operating temperature. The performance of grease lubricated Hi-eX decreases at bearing temperatures above 40 °C. This loss of performance is related to both material and lubricant effects.

For a given  $\bar{p}U$  Factor the operating temperature of the bearing depends upon

the temperature of the surrounding environment and the heat dissipation properties of the housing.

In calculating the service life of Hi-eX these effects are accommodated by the application factor  $a_T$  shown in Fig. 18

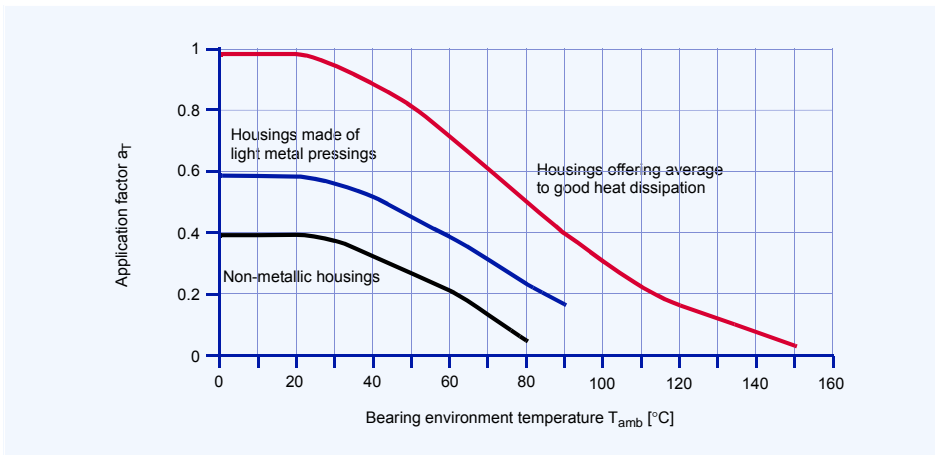

Fig. 18: Hi-eX application factor  $a_T$

### 5.6 Mating Surface

The wear rate of Hi-eX is strongly dependent upon the roughness of the mating counterface. For optimum bearing performance the mating surface should be

ground to better than  $0.4 \mu m R_a$ . This effect is accommodated by the mating surface finish application factor  $a_S$  shown in Fig. 19.

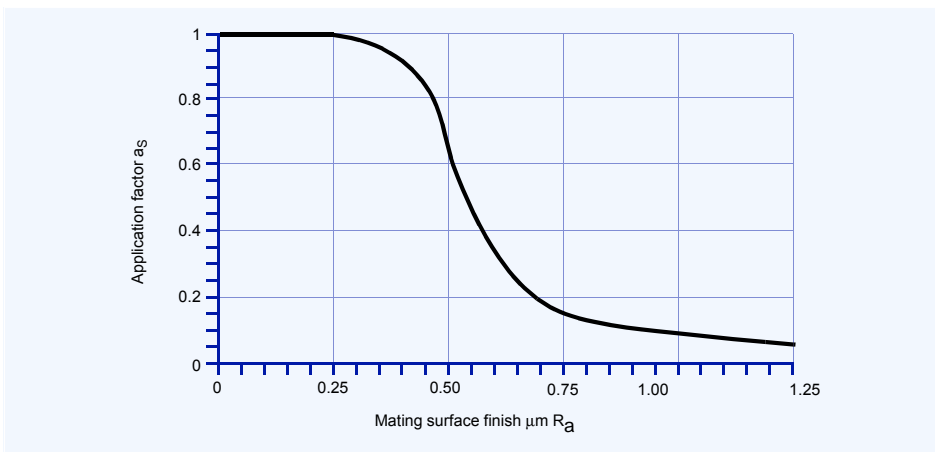

Fig. 19: Hi-eX application factor  $a_S$

5 Design Factors

5.7 Bearing Size

Frictional heat generated at the bearing surface and dissipated through the shaft and housing depends both on the operating conditions (i.e.  $\bar{p}U$  factor) and the bearing size.

For a give  $\bar{p}U$  condition a large bearing will run hotter than a smaller bearing. The bearing size factor  $a_B$  shown in Fig. 20 takes account of this effect.

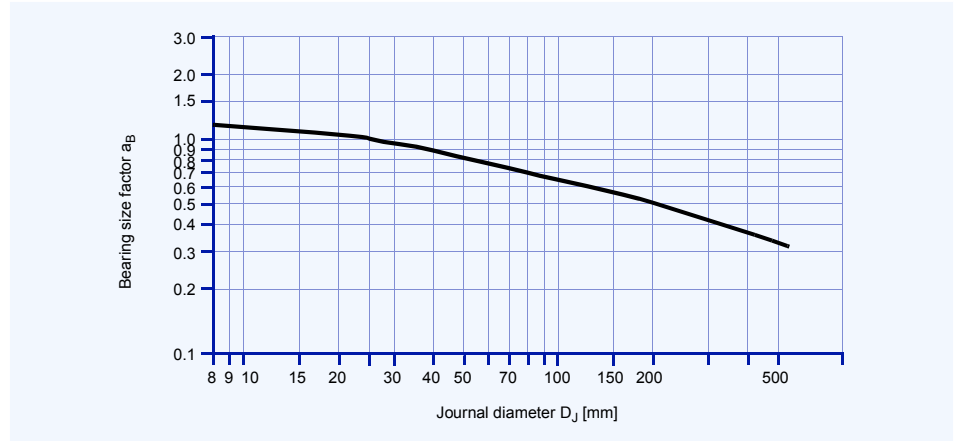

Fig. 20: Bearing size factor  $a_B$

Note:  $a_B = 1$  for slideways

5.8 Estimation of Bearing Service Life with Grease Lubrication

Calculation Parameters

Bushes		Thrust Washers		Slide Plates		Unit
Bearing diameter	$D_i$	Bearing outside diameter	$D_o$	Bearing Length	L	[mm]
Bearing length	B	Bearing inside diameter	$D_i$	Bearing Width	W	[mm]

Operating Conditions

Load	F	[N]
Rotational Speed (Continuous)	N	[1/min]
Oscillating Frequency	$N_{osz}$	[1/min]
Angular movement about mean position	$\varphi$	[°]
Specific Load Limit	see Table 5, Page 13	[N/mm <sup>2</sup> d]
Application Factor $a_Q$	see Fig. 15-17, Page 16	[-]
Application Factor $a_T$	see Fig. 18, Page 17	[-]
Application Factor $a_S$	see Fig. 19, Page 17	[-]
Bearing Size Factor $a_B$	see Fig. 20, Page 18	[-]

Calculate  $\bar{p}$  from the equations in 5.1 on Page 13.

Calculate U from the equations in 5.2 on Page 14.

Calculate  $\bar{p}U$  from the equation in 5.3 on Page 15.

Calculate High Load Factor  $a_E$

$$(5.8.1) \quad a_E = \frac{\bar{p}_{lim}}{\bar{p}_{lim} - \bar{p}} \quad [-]$$

**Note:**

If  $a_E > 10000$ , or  $a_E < 0$ , the bearing is overloaded.

Calculate Effective  $\bar{p}U$  Factor  $e\bar{p}U$

$$(5.8.2) \quad e\bar{p}U = \frac{a_E \cdot \bar{p}U}{a_B} \quad [-]$$

**Note:**

Check that  $e\bar{p}U$  is less than limit set in Fig. 11 for the sliding speed U. If NOT, increase the bearing length or use continuous lubrication.

**Estimate Bearing Life**

If  $e\bar{p}U < 1.0$  then

$$(5.8.3) \quad L_H = \frac{3000}{e\bar{p}U} \cdot a_Q \cdot a_T \cdot a_S \quad [h]$$

If  $e\bar{p}U > 1.0$  then

$$(5.8.4) \quad L_H = \frac{3000}{e\bar{p}U^{2.4}} \cdot a_Q \cdot a_T \cdot a_S \quad [h]$$

**Estimate Re-greasing Interval**

$$(5.8.5) \quad L_{RG} = \frac{L_H}{2} \quad [h]$$

**Oscillating Motion and Dynamic Loads**

**Oscillating Motion**

Calculate number of cycles

$$(5.8.6) \quad Z_T = L_{RG} \cdot N_{osz} \cdot 60 \cdot (R + 2) \quad [-]$$

**Dynamic Loads**

Calculate number of cycles

$$(5.8.7) \quad C_T = L_{RG} \cdot C \cdot 60 \cdot (R + 2) \quad [-]$$

where R = Number of times bearing is regreased during total life required.

Check that  $Z_T$  (or  $C_T$ ) is less than the total number of cycles Q given in Fig. 9 for actual bearing specific load  $\bar{p}$ .

If  $Z_T$  (or  $C_T$ ) > Q then life will be limited by fatigue after Q cycles.

If  $Z_T$  (or  $C_T$ ) < Q then life will be limited by wear after  $Z_T$  cycles.

If the estimated life or total cycles are insufficient or the regreasing intervals are too frequent, increase the bearing length or diameter, or consider drip feed or continuous oil lubrication, the quantity to be established by test.



5 Design Factors

5.9 Worked Examples

PM cylindrical Bush

<b>Given:</b>			
Load Details	Steady Load	Inside Diameter $D_i$	40 mm
	Direction: down	Length B	30 mm
Shaft	Steel, $R_a = 0.4 \mu\text{m}$	Bearing Load F	20000 N
	Temperature 85 °C	Rotational Speed N	30 1/min
Housing	Light metal - poor heat dissipation		

<b>Calculation Constants and Application Factors</b>			
Specific Load Limit $\bar{p}_{lim}$ at 85 °C	81.5 N/mm <sup>2</sup>	(Table 5, Page 13)	
Application Factor $a_T$	0.2	(Fig. 18, Page 17)	
Mating Surface Application Factor $a_S$	0.85	(Fig. 19, Page 17)	
Bearing Size Factor $a_B$ for $\phi 40$	0.95	(Fig. 20, Page 18)	
Application Factor for PM bush $a_Q$	1.8	(Fig. 16, Page 16)	

Calculation	Ref	Value
Specific Load $\bar{p}$ [N/mm <sup>2</sup> ]	(5.1.1), Page 13	$\bar{p} = \frac{F}{D_i \cdot B} = \frac{20000}{40 \cdot 30} = 16.67$
Sliding Speed U [m/s]	(5.2.1), Page 14	$U = \frac{D_i \cdot \pi \cdot N}{60 \cdot 10^3} = \frac{40 \cdot \pi \cdot 30}{60000} = 0.063$
High Load Factor $a_E$ [-] (must be >0)	(5.8.1), Page 19	$a_E = \frac{\bar{p}_{lim}}{\bar{p}_{lim} - \bar{p}} = \frac{81.5}{81.5 - 16.67} = 1.25$
epU Factor [-]	(5.8.2), Page 19	$e\bar{p}U = \frac{a_E \cdot \bar{p}U}{a_B} = \frac{1.25 \cdot 16.67 \cdot 0.063}{0.95} = 1.382$
Life $L_H$ [h] for $e\bar{p}U > 1$	(5.8.3), Page 19	$L_H = \frac{3000}{e\bar{p}U^{2.4}} \cdot a_Q \cdot a_T \cdot a_S = \frac{3000}{1.382^{2.4}} \cdot 1.8 \cdot 0.2 \cdot 0.85 = 434$
$L_{RG}$ [h]	(5.8.3), Page 19	$L_{RG} = \frac{L_H}{2} = \frac{434}{2} = 217$

PM cylindrical Bush

<b>Given:</b>			
Load Details	Steady Load	Inside Diameter $D_i$	100 mm
	Direction: up	Length B	60 mm
Shaft	Steel, $R_a = 0.3 \mu\text{m}$	Bearing Load F	45000 N
	Temperature 80 °C	Rotational Speed N	35 1/min
Housing	good heat dissipation		

<b>Calculation Constants and Application Factors</b>			
Specific Load Limit $\bar{p}_{lim}$ at 40 °C	90 N/mm <sup>2</sup>	(Table 5, Page 13)	
Application Factor $a_T$	0.50	(Fig. 18, Page 17)	
Mating Surface Application Factor $a_S$	1.00	(Fig. 19, Page 17)	
Bearing Size Factor $a_B$ for $\phi 100$	0.65	(Fig. 20, Page 18)	
Application Factor for PM bush $a_Q$	1.0	(Fig. 16, Page 16)	

Calculation	Ref	Value
Specific Load $\bar{p}$ [N/mm <sup>2</sup> ]	(5.1.1), Page 13	$\bar{p} = \frac{F}{D_i \cdot B} = \frac{45000}{100 \cdot 60} = 7.50$
Sliding Speed U [m/s]	(5.2.1), Page 14	$U = \frac{D_i \cdot \pi \cdot N}{60 \cdot 10^3} = \frac{100 \cdot \pi \cdot 35}{60000} = 0.183$
High Load Factor $a_E$ [-] (must be >0)	(5.8.1), Page 19	$a_E = \frac{\bar{p}_{lim}}{\bar{p}_{lim} - \bar{p}} = \frac{90}{90 - 7.50} = 1.091$
epU Factor [-]	(5.8.2), Page 19	$e\bar{p}U = \frac{a_E \cdot \bar{p}U}{a_B} = \frac{1.091 \cdot 7.5 \cdot 0.183}{0.65} = 2.307$
Life $L_H$ [h] for $e\bar{p}U > 1$	(5.8.3), Page 19	$L_H = \frac{3000}{e\bar{p}U^{2.4}} \cdot a_Q \cdot a_T \cdot a_S = \frac{3000}{2.307^{2.4}} \cdot 1.0 \cdot 1.0 \cdot 0.5 = 202$
$L_{RG}$ [h]	(5.8.3), Page 19	$L_{RG} = \frac{L_H}{2} = \frac{202}{2} = 101$

MB cylindrical bush

<b>Given:</b>			
Load Details	Steady Load, oscillating	Inside Diameter $D_i$	80 mm
	Direction: down	Length B	40 mm
Shaft	Steel, $R_a = 0.3 \mu\text{m}$	Bearing Load F	200000 N
	ambient Temperature	Frequency $N_{osz}$	5 1/min
Housing	Light metal - poor heat dissipation		
	Angle $\phi$		20°

<b>Calculation Constants and Application Factors</b>			
Specific Load Limit $\bar{p}_{lim}$	140 N/mm <sup>2</sup>	(Table 5, Page 13)	
Application Factor $a_T$	0.60	(Fig. 18, Page 17)	
Mating Surface Application Factor $a_S$	1.00	(Fig. 19, Page 17)	
Bearing Size Factor $a_B$ for $\phi 80$	0.75	(Fig. 20, Page 18)	
Application Factor for MB bush $a_Q$	1.80	(Fig. 16, Page 16)	

Calculation	Ref	Value
Specific Load $\bar{p}$ [N/mm <sup>2</sup> ]	(5.1.1), Page 13	$\bar{p} = \frac{F}{D_i \cdot B} = \frac{200000}{80 \cdot 40} = 62.5$
Sliding Speed U [m/s]	(5.2.3), Page 14	$U = \frac{D_i \cdot \pi \cdot 4\phi \cdot N_{osz}}{60 \cdot 10^3} = \frac{80 \cdot \pi \cdot 4 \cdot 20 \cdot 1.11}{60000 \cdot 360} = 0.001$
High Load Factor $a_E$ [-] (must be >0)	(5.8.1), Page 19	$a_E = \frac{\bar{p}_{lim}}{\bar{p}_{lim} - \bar{p}} = \frac{140}{140 - 62.5} = 1.806$
epU Factor [-]	(5.8.2), Page 19	$e\bar{p}U = \frac{a_E \cdot \bar{p}U}{a_B} = \frac{1.806 \cdot 62.5 \cdot 0.001}{0.75} = 0.151$
Life $L_H$ [h] for $e\bar{p}U < 1$	(5.8.3), Page 19	$L_H = \frac{3000}{e\bar{p}U} \cdot a_Q \cdot a_T \cdot a_S = \frac{3000}{0.151} \cdot 1.8 \cdot 0.6 \cdot 1.0 = 21456$
$L_{RG}$ [h]	(5.8.3), Page 19	$L_{RG} = \frac{L_H}{2} = \frac{21456}{2} = 10728$
$Z_T$ [-]	(5.8.3), Page 19	$Z_T = L_{RG} \cdot N_{osz} \cdot 60 \cdot (R+2) = 10728 \cdot 5 \cdot 60 \cdot 2 = 6.44 \cdot 10^6$ Q for $\bar{p} = 62.5 = 1.5 \times 10^6$ ; $Z_T > Q$ Therefore bearing fails by fatigue after $1.5 \times 10^6$ cycles

Thrust washer

<b>Given:</b>			
Load Details	Steady Load	Inside Diameter $D_i$	40 mm
	Direction: down	Outside Diameter $D_o$	78 mm
Counterface	Steel, $R_a = 0.2 \mu\text{m}$	Bearing Load F	50000 N
	Temperature 50 °C	Rotational Speed N	25 1/min
Housing	Light metal - poor heat dissipation		

<b>Calculation Constants and Application Factors</b>			
Specific Load Limit $\bar{p}_{lim}$	90 N/mm <sup>2</sup>	(Table 5, Page 13)	
Application Factor $a_T$ for 50 °C	0.50	(Fig. 18, Page 17)	
Mating Surface Application Factor $a_S$	1.00	(Fig. 19, Page 17)	
Bearing Size Factor $a_B$ for $\phi 40$	0.95	(Fig. 20, Page 18)	
Application Factor for Thrust washers $a_Q$	1.00	(Fig. 17, Page 16)	

Calculation	Ref	Value
Specific Load $\bar{p}$ [N/mm <sup>2</sup> ]	(5.1.1), Page 13	$\bar{p} = \frac{4 \cdot F}{\pi \cdot (D_o^2 - D_i^2)} = \frac{4 \cdot 50000}{\pi \cdot (78^2 - 40^2)} = 14.20$
Sliding Speed U [m/s]	(5.2.2), Page 14	$U = \frac{D_o + D_i}{2} \cdot \pi \cdot N = \frac{78 + 40}{2} \cdot \pi \cdot 25 = \frac{2 \cdot 59 \cdot \pi \cdot 25}{60 \cdot 10^3} = 0.0772$
High Load Factor $a_E$ [-] (must be >0)	(5.8.1), Page 19	$a_E = \frac{\bar{p}_{lim}}{\bar{p}_{lim} - \bar{p}} = \frac{90}{90 - 14.20} = 1.187$
epU Factor [-]	(5.8.2), Page 19	$e\bar{p}U = \frac{a_E \cdot \bar{p}U}{a_B} = \frac{1.187 \cdot 14.20 \cdot 0.0772}{0.95} = 1.370$
Life $L_H$ [h] for $e\bar{p}U > 1$	(5.8.3), Page 19	$L_H = \frac{3000}{e\bar{p}U^{2.4}} \cdot a_Q \cdot a_T \cdot a_S = \frac{3000}{1.370^{2.4}} \cdot 1.0 \cdot 0.5 \cdot 1.0 = 704$
$L_{RG}$ [h]	(5.8.3), Page 19	$L_{RG} = \frac{L_H}{2} = \frac{704}{2} = 352$

# 6 Data Sheet

Application: \_\_\_\_\_

## 6.1 Data for bearing design calculations

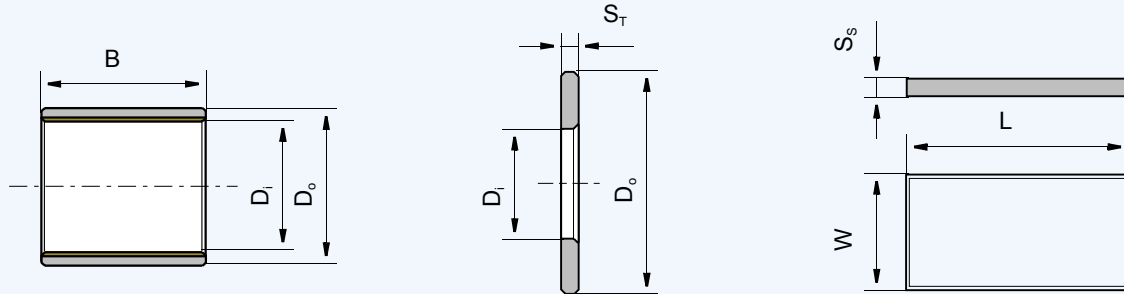

- Cylindrical Bush   
  Thrust Washer   
  Slideplate   
  Special (Sketch)

- Rotational movement   
  Steady load   
  Rotating load   
  Oscillating movement   
  Linear movement

- Existing Design   
  New Design

Quantity

**Dimensions in mm**

Inside Diameter  $D_i$    
 Outside Diameter  $D_o$    
 Length  $B$    
 Length of slideplate  $L$    
 Width of slideplate  $W$    
 Thickness of slideplate  $S_s$

**Load**

Radial load  $F$  [N]   
 or specific load  $\bar{p}$  [N/mm<sup>2</sup>]

Axial load  $F$  [N]   
 or specific load  $\bar{p}$  [N/mm<sup>2</sup>]

**Movement**

Rotational speed  $N$  [1/min]   
 Speed  $U$  [m/s]   
 Length of Stroke  $L_s$  [mm]   
 Frequency of Stroke [1/min]   
 Oscillating cycle  $\phi$  [°]   
 Oscillating frequency  $N_{osz}$  [1/min]

**Service hours per day**

Continuous operation   
 Intermittent operation   
 Operating time   
 Days per year

**Fits and Tolerances**

Shaft  $D_J$    
 Bearing Housing  $D_H$

**Operating Environment**

Ambient temperature  $T_{amb}$  [°]   
 Housing with good heat transfer properties   
 Light pressing or insulated housing which poor heat transfer properties   
 Non metal housing with poor heat transfer properties   
 Alternate operation in water and dry

**Mating surface**

Material   
 Hardness HB/HRC   
 Surface finish  $R_a$  [ $\mu$ m]

**Lubrication**

Dry   
 Continuous lubrication   
 Process fluid lubrication   
 Initial lubrication only   
 Hydrodynamic conditions   
 Process Fluid   
 Lubricant   
 Dynamic viscosity  $\eta$

**Service life**

Required service life  $L_H$  [h]

Customer Data  
 Company:  
 Street:

City:  
 Post Code:

Project:  
 Name:  
 Tel.:

Date:  
 Signature:  
 Fax:

## 7 Bearing Assembly

### 7.1 Dimensions and Tolerances

For optimum performance it is essential that the correct running clearance is used and that both the diameter of the shaft and the bore of the housing are finished to the limits given in the tables.

If the bearing housing is unusually flexible the bush will not close in by the calculated

amount and the running clearance will be more than the optimum. In these circumstances the housing should be bored slightly undersize or the journal diameter increased, the correct size being determined by experiment.

### 7.2 Tolerances for minimum clearance

#### Grease lubrication

The minimum clearance required for satisfactory performance of Hi-eX depends upon the  $\bar{p}U$  factor, the sliding speed and the environmental temperature, any one or combination of which may reduce the diametral clearance in operation due to inward thermal expansion of the Hi-eX polymer lining. It is therefore necessary to compensate for this.

Fig. 21 shows the minimum diametral clearance plotted stepped against journal diameter at an ambient 20 °C. Where the stepped lines show a change of clearance for a given journal diameter, the lower value is used.

The superimposed straight lines indicate the minimum permissible diametral clear-

ance for various values of  $\bar{p}Uu$  (Fig. 21), where  $\bar{p}U$  is calculated as in 5.3 on Page 15, and  $u$  is a sliding speed factor for speeds in excess of 0.5 m/s given in Fig. 22.

If the clearance indicated for a  $\bar{p}Uu$  factor lies below the stepped lines the recommended standard shaft may be used. If above, the shaft size must be reduced to obtain the clearance indicated on the vertical axis of the relevant figure.

Under slow speed and high load conditions it may be possible to achieve satisfactory performance with diametral clearances less than those indicated. But adequate prototype testing is recommended in such cases.

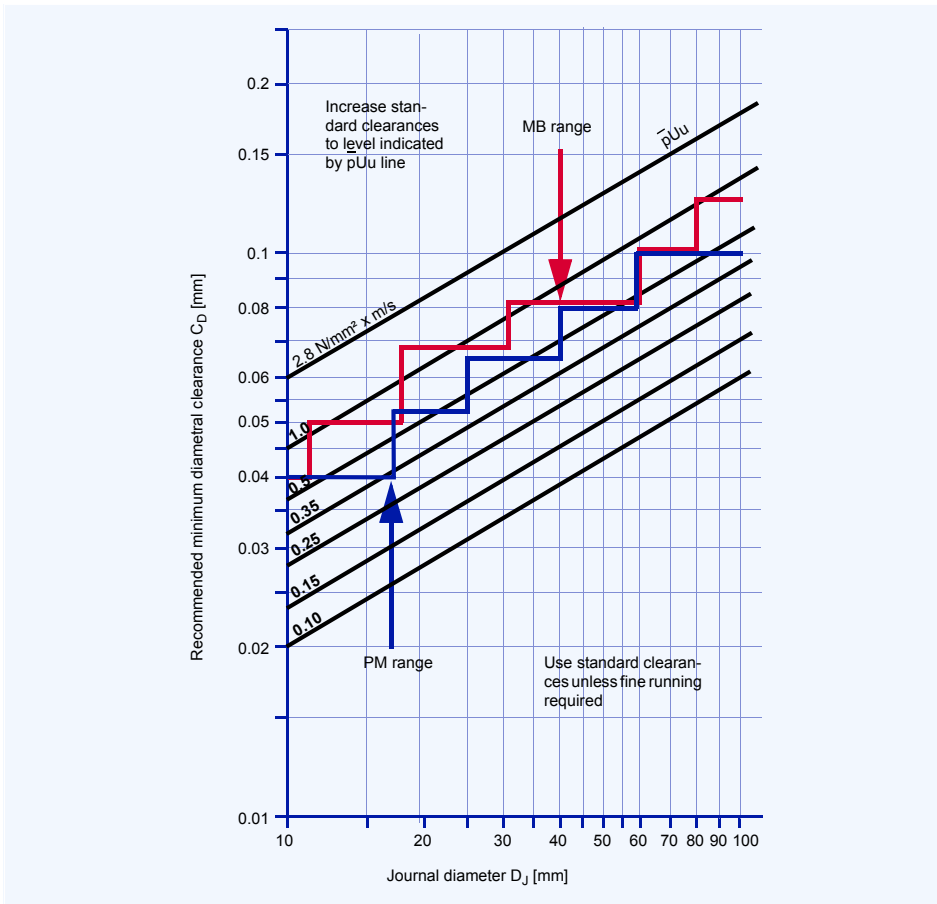

Fig. 21: Minimum clearance for PM prefinished and MB machinable range machined to H7 bore

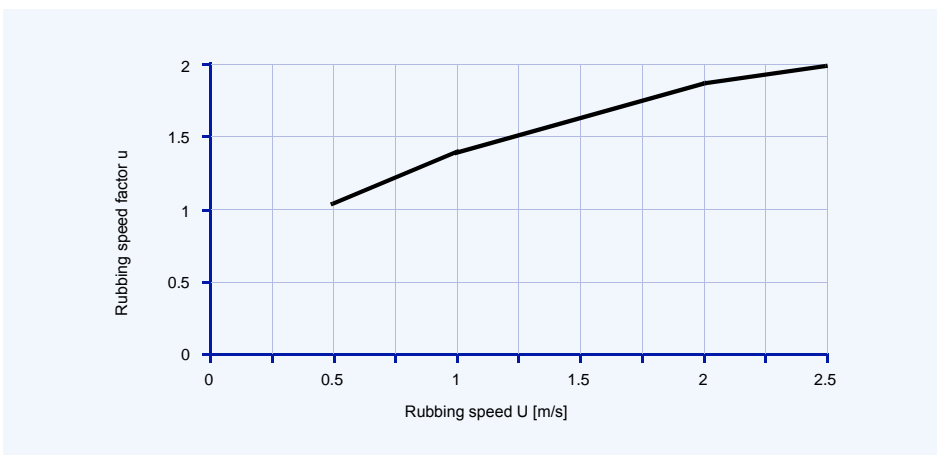

Fig. 22: Rubbing speed factor  $u$

# 5 Design Factors

## Fluid Lubrication

The minimum clearance required for journal bearings operating under hydrodynamic or mixed film conditions for a range of shaft rotational speeds and diameters is

shown in Fig. 23. It is recommended that the bearing performance under minimum clearance conditions be confirmed by testing if possible.

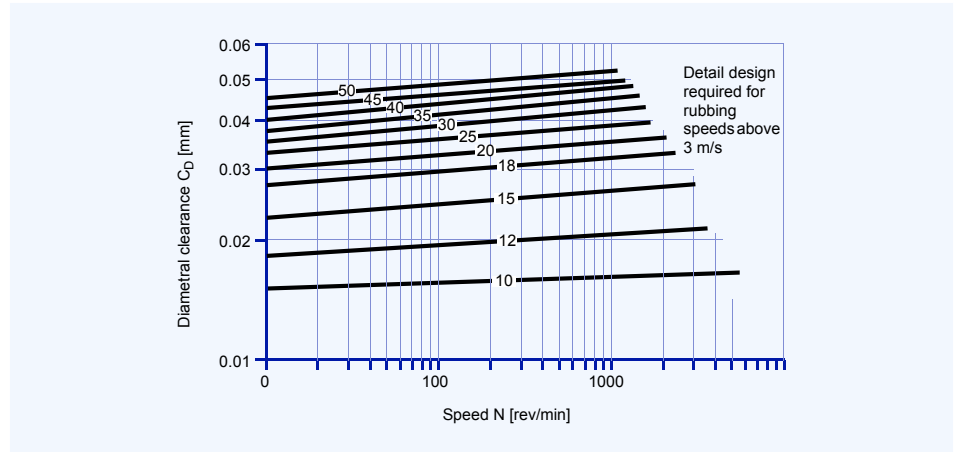

Fig. 23: Hi-eX minimum clearances - bush diameters  $D_i$  10-50 mm

## Allowance for Thermal Expansion

For operation in high temperature environments the clearance should be increased by the amounts indicated by Fig. 24 to

compensate for the inward thermal expansion of the bearing lining.

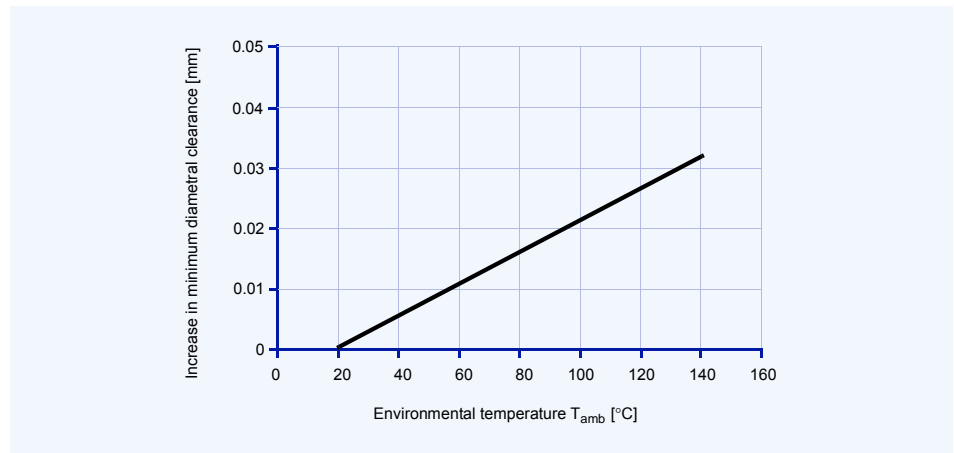

Fig. 24: Recommended increase in diametral clearance

If the housing is non-ferrous then the bore should be reduced by the amounts given in Table 5, in order to give an increased inter-

ference fit to the bush, with a similar reduction in the journal diameter additional to that indicated by Fig. 24.

Housing material	Reduction in housing diameter per 100°C rise	Reduction in shaft diameter per 100°C rise
Aluminium alloys	0.1%	0.1% + values from Fig. 24
Copper base alloys	0.05%	0.05% + values from Fig. 24
Steel and cast iron	Nil	values from Fig. 24
Zinc base alloys	0.15%	0.15% + values from Fig. 24

Table 6: Allowance for high temperature

### 7.3 Counterface Design

Hi-eX bearings may be used with all conventional mating surface materials. Hardening of steel journals is not required unless abrasive dirt is present or if the projected bearing life is in excess of 2000 hours, in which cases a minimum shaft hardness of 350HB is recommended.

A ground surface finish of better than  $0.4 \mu\text{m } R_a$  is recommended. The final direction of machining of the mating surface should preferably be the same as the direction of motion relative to the bearing in service.

Hi-eX is normally used in conjunction with ferrous journals and thrust faces, but in damp or corrosive surroundings stainless steel, hard chromium plated mild steel, or

alternatively WH shaft sleeves are recommended. When plated mating surfaces are specified the plating should possess adequate strength and adhesion, particularly if the bearing is to operate with high fluctuating loads.

The shaft or thrust collar used in conjunction with the Hi-eX bush or thrust washer must extend beyond the bearing surface in order to avoid cutting into it. The mating surface must also be free from grooves or flats, the end of the shaft should be given a lead-in chamfer and all sharp edges or projections which may damage the soft polymer lining of the Hi-eX must be removed.

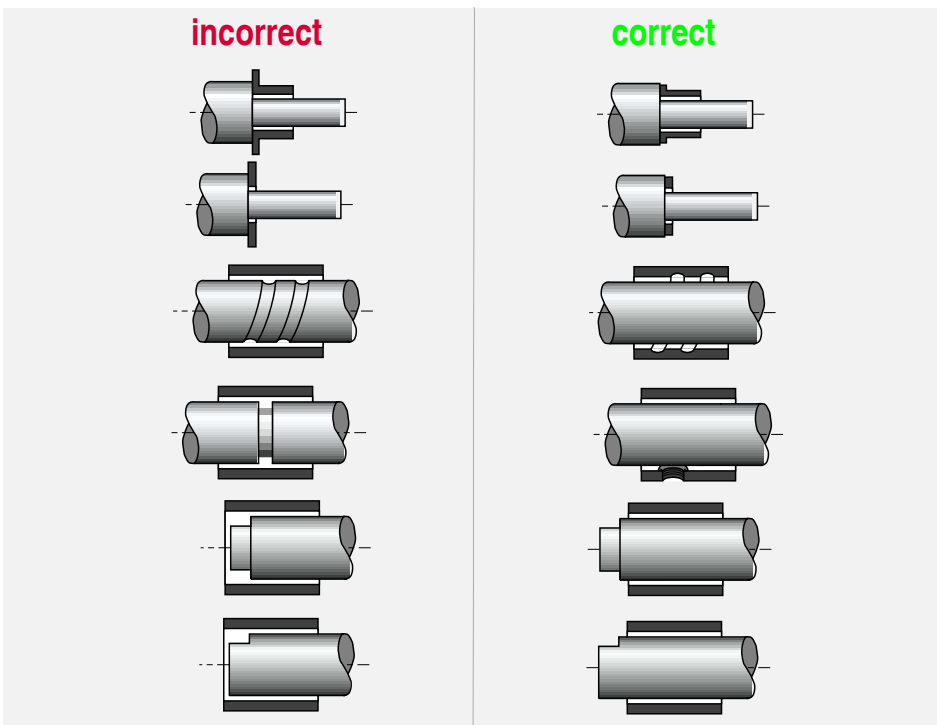

Fig. 25: Counterface design



5 Design Factors

7.4 Installation

Important Note

Care must be taken to ensure that the Hi-eX lining material is not damaged during the installation.

Fitting of Bushes

The bush is inserted into its housing with the aid of a stepped mandrel, preferably made from case hardened mild steel, as shown in Fig. 26. The following should be noted to avoid damage to the bearing:

- Housing diameter is as recommended
- 15-20 deg lead-in chamfer on housing
- The bush must be square to the housing
- Light smear of oil on bush OD

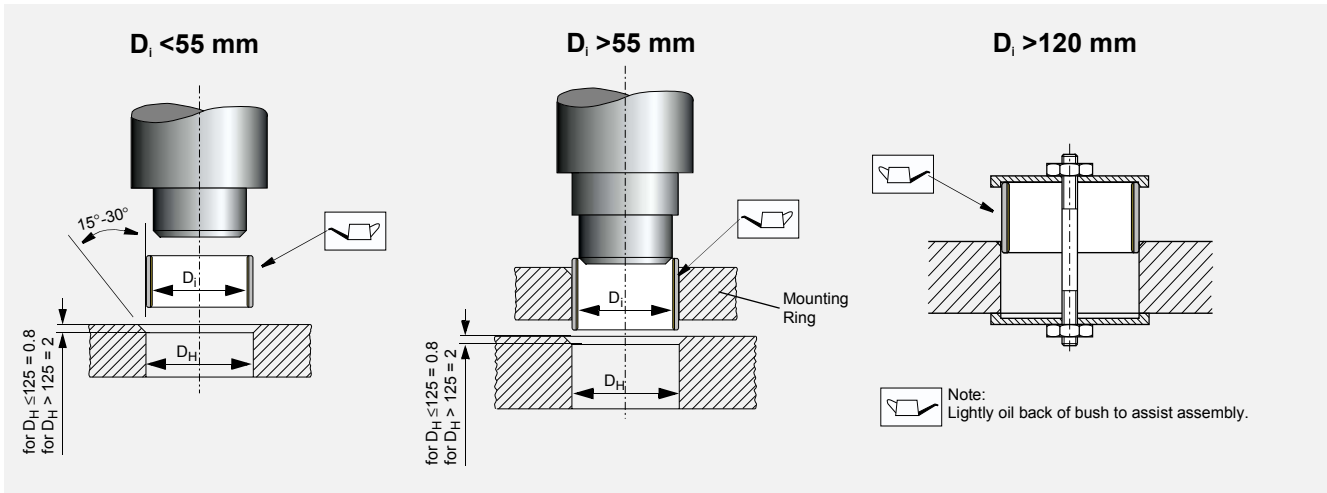

Fig. 26: Fitting of bushes

Insertion Forces

Fig. 27 gives an indication of the maximum standard Hi-eX bushes insertion force required to correctly install

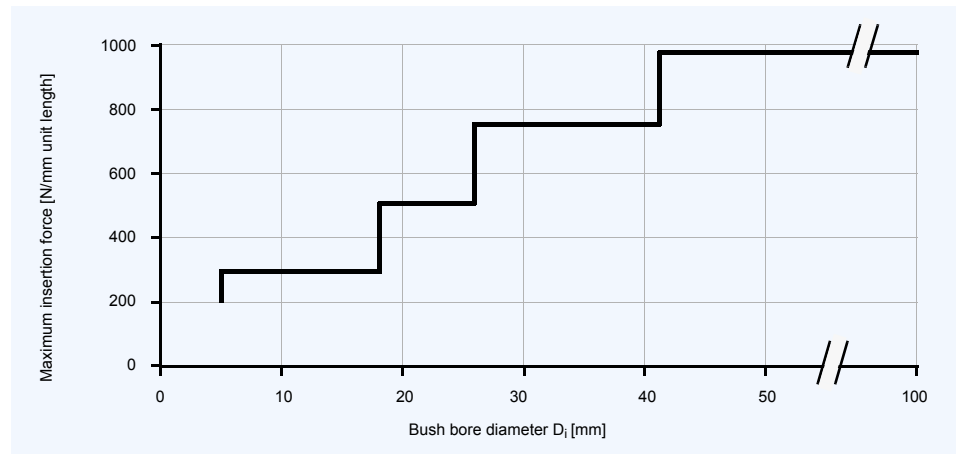

Fig. 27: Maximum insertion force  $F_i$

## Alignment

Accurate alignment is an important consideration for all bearing assemblies. With Hi-eX bearings misalignment over the

length of a bush (or pair of bushes), or over the diameter of a thrust washer should not exceed 0.020 mm as illustrated in Fig. 28.

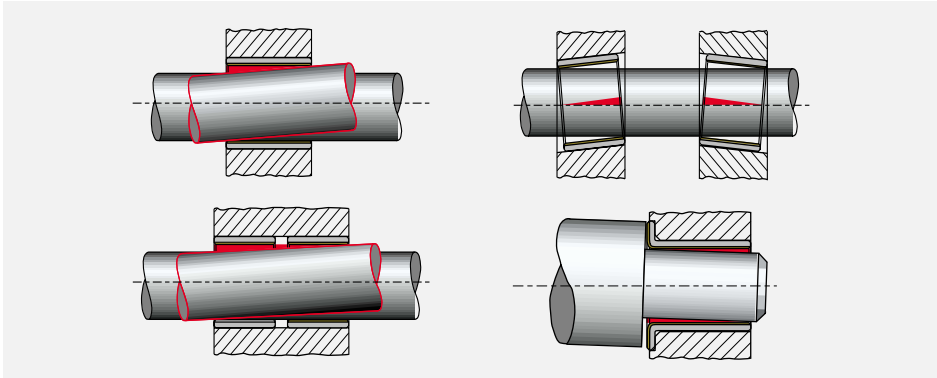

Fig. 28: Alignment

## Sealing

While Hi-eX can tolerate the ingress of some contaminant materials into the bearing without loss of performance, where there is the possibility of highly

abrasive material entering the bearing, a suitable sealing arrangement, as illustrated in Fig. 29 should be provided.

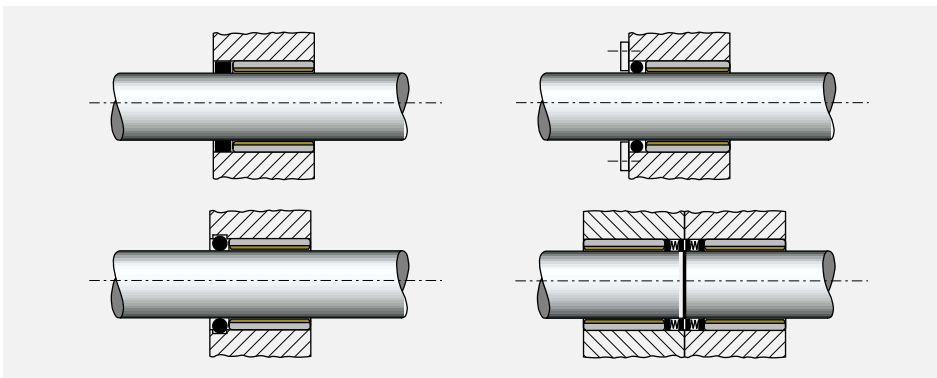

Fig. 29: Recommended sealing arrangements

## Axial Location

Where axial location is necessary, it is generally advisable to fit Hi-eX thrust washers in conjunction with Hi-eX bushes, even when the axial loads are low. Experi-

ence has shown that fretting debris from unsatisfactory locating surfaces can enter an adjacent Hi-eX bush and adversely affect the bearing life and performance.

## Fitting of Thrust Washers

Hi-eX thrust washers should be located on the outside diameter in a recess as shown in Fig. 30. The inside diameter must be clear of the shaft in order to prevent contact with the steel backing of the Hi-eX material. The recess diameter should be 0.125 mm larger than the washer diameter and the depth as given in the product tables.

If there is no recess for the thrust washer one of the following methods of fixing may be used:

- two dowel pins
- two screws
- adhesive

**5 Design Factors**

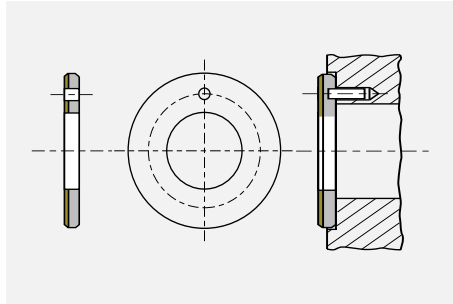

Fig. 30: Installation of Thrust-Washer

**Important Note**

- Dowel pins should be recessed 0.25 mm below the bearing surface
- Screws should be countersunk 0.25 mm below the bearing surface
- Hi-eX must not be heated above 250 °C
- Contact adhesive manufacturers for guidance on the selection of suitable adhesives
- Protect the bearing surface to prevent contact with adhesive
- Ensure the washer ID does not touch the shaft after assembly
- Ensure that the washer is mounted with the steel backing to the housing

**Slideways**

Hi-eX strip material for use as slideway bearings should be installed using one of the following methods:

- countersunk screws
- adhesives
- mechanical location

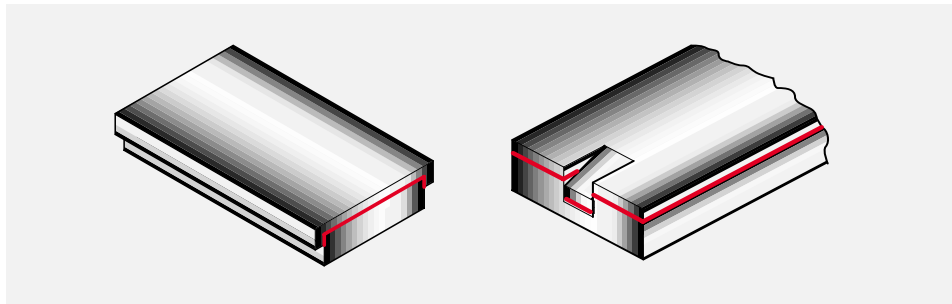

Fig. 31: Mechanical location of Hi-eX slideways

## 8 Machining

### 8.1 Machining Practice

The PEEK polymer lining of Hi-eX has good machining characteristics and can be treated as a free cutting brass in most respects. The indents in the bearing surface may lead to the formation of burrs or whiskers due to the resilience of the lining material, but this can be avoided by using machining methods which remove the lining as a ribbon, rather than a narrow thread.

When machining Hi-eX it is recommended that not more than 0.125 mm is removed from the lining thickness in order to ensure that the lubricant capacity of the indents remaining after machining is not significantly reduced.

Boring, reaming and broaching are all suitable machining methods for use with Hi-eX. The recommended tool material is high speed steel or tungsten carbide, respectively diamonds for long tool service times.

### 8.2 Boring

Fig. 32 illustrates a recommended boring tool which should be mounted with its axis at right angles to the direction of feed.

The essential characteristic required in the boring tool is a tip radius greater than 1.5 mm, which combined with a side rake of 30° will produce the ribbon effect required.

Cutting speeds should be high, the optimum between 2.0 and 4.5 m/s. The feed should be low, in the range 0.05/0.025 mm for cuts of 0.125 mm, the lower feeds being used with the higher cutting speeds.

Satisfactory finishes can usually be obtained machining dry and an air blast may facilitate swarf removal. The use of coolant is not detrimental.

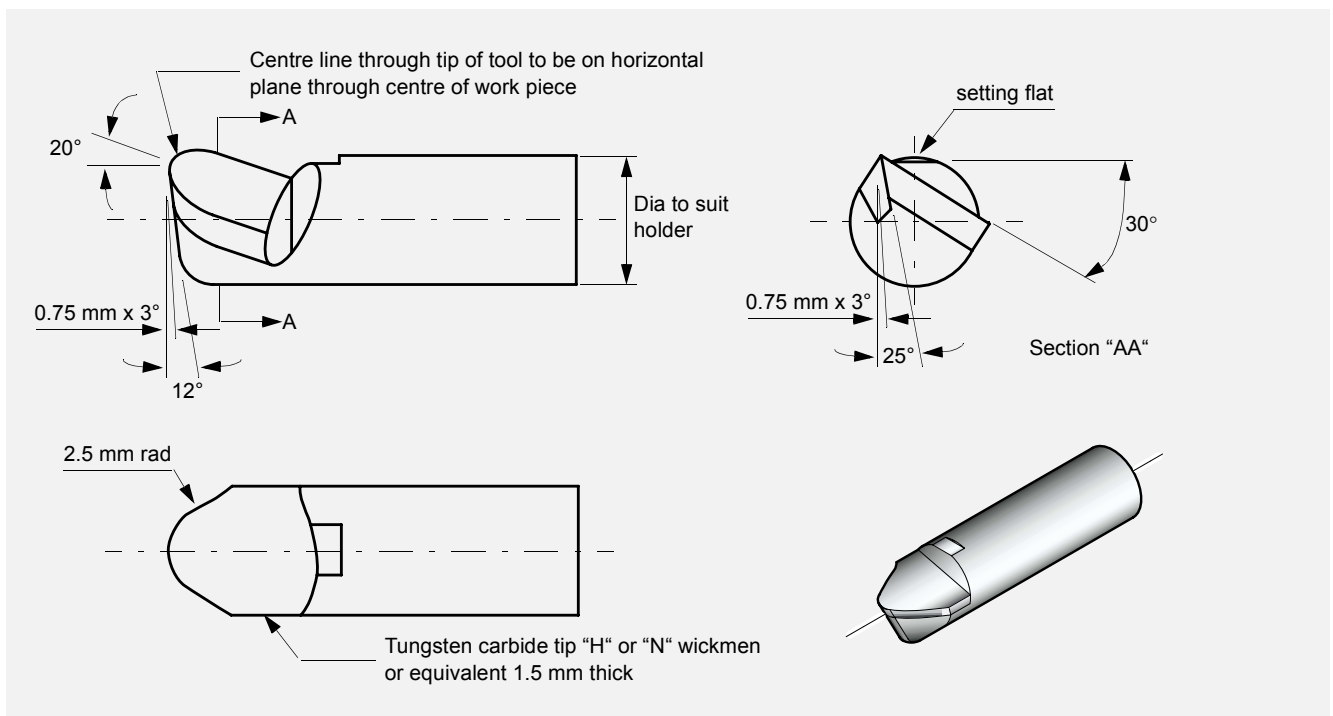

Fig. 32: Boring tool for Hi-eX

# 8 Machining

## 8.3 Reaming

Hi-eX can be reamed satisfactorily by hand with a straight-fluted expanding reamer. For best results the reamer should be sharp, the cut 0.025-0.050 mm and the

feed slow. Where hand reaming is not desired machining speeds of about 0.05 m/s are recommended with the cuts and feeds as for boring.

## 8.4 Broaching

Fig. 33 shows broaches suitable for finishing bushes up to 65 mm diameter.

The broach should be used dry, at a speed of 0.1-0.5 m/s.

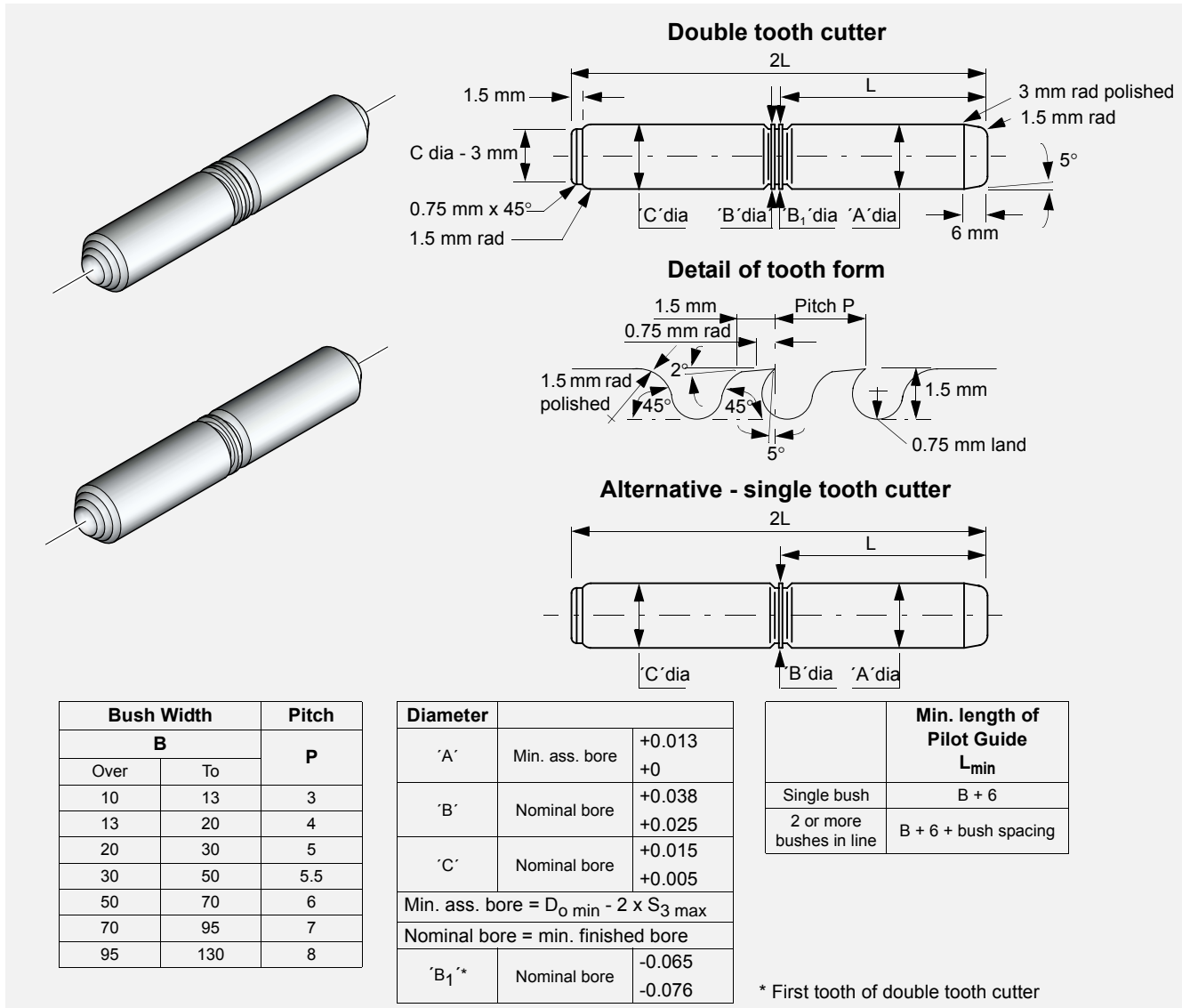

Fig. 33: Suitable broaches for Hi-eX

Use the single tooth version where the bush is less than 25 mm long, and the double tooth broach for longer bushes or for two or more bushes together.

If it is necessary to make up a special form of broach the following points should be noted:

- Adequate provision should be made for locating the bush by providing a pilot to suit the bore of the bush when pressed home. A rear support shoulder should locate in the broached bore of the bush after cutting. Alternatively, special guides may be provided external to the work-piece.

- If two bushes are to be broached in line, then the pilot guide and rear support should be longer than the distance between the two bushes.
- For large bushes it may be necessary to provide axial relief along the length of the pilot guide and rear support, in order to reduce the broaching forces.

- Unless a guided broach is used, the tool will follow the initial bore alignment of the bush, broaching cannot improve concentricity and parallelism unless external guides are used.

In general owing to the variation in wall thickness of large diameter bushes, broaching is not suitable for finishing bores of more than 60 mm diameter unless external guides are used.

## 8.5 Vibrobroaching

This technique may also be used. A single cutter is propelled with progressive reciprocating motion with a vibration frequency of typically 50 Hz. The cutter should have a primary rake of  $1.5^\circ$  for 0.5 mm. A cut of

0.25 mm on diameter may be made at an average cutting speed of 0.15 m/s to give a surface finish of better than  $0.8 \mu\text{m } R_a$ , which is acceptable.

## 8.6 Modification of components

The modification of Hi-eX bearing components requires no special procedures. In general it is more satisfactory to perform machining or drilling operations from the polymer lining side in order to avoid burrs. When cutting is done from the steel side,

the minimum cutting pressure should be used and care taken to ensure that any steel or bronze particles protruding into the remaining bearing material, and all burrs, are removed.

## 8.7 Drilling Oil Holes

Bushes should be adequately supported during the drilling operation to ensure that

no distortion is caused by the drilling pressure.

## 8.8 Cutting Strip Material

Hi-eX strip material may be cut to size by any one of the following methods. Care must be taken to protect the bearing surface from damage and to ensure that no deformation of the strip occurs.

- Using side and face cutter, or slitting saw, with the strip held flat and securely on a horizontal milling machine.
- Cropping
- Guillotine (For widths less than 90 mm only)
- Water-jet cutting, Laser cutting



## 9 Electroplating

### Hi-eX Components

To provide corrosion protection the mild steel backing of Hi-eX may be electroplated with most of the conventional electroplating metals including the following:

- zinc ISO 2081-2
- nickel ISO 1456-8
- hard chromium ISO 1456-8

For the harder materials if the specified plating thickness exceeds approximately

5 µm then the housing diameter should be increased by twice the plating thickness in order to maintain the correct assembled bearing bore size.

Where electrolytic attack is possible tests should be conducted to ensure that all the materials in the bearing environment are mutually compatible.

### Mating Surfaces

Hi-eX can be used against hard chrome plated materials and care should be taken to ensure that the recommended shaft

sizes and surface finish are achieved after the plating process.

### Note:

The parts shown in the following tables are not available from stock.

# 10 Standard Products

## 10.1 PM-HX cylindrical bushes

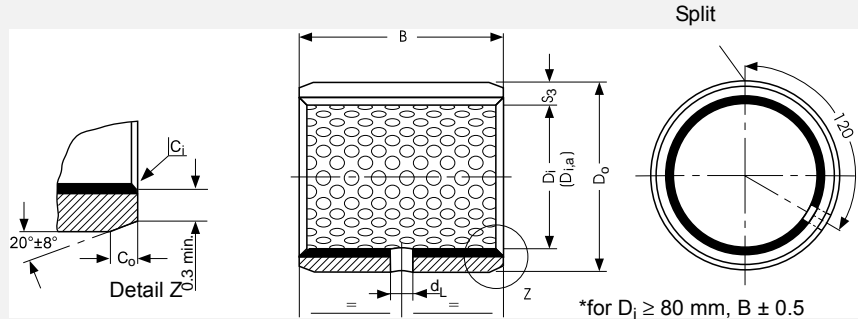

Dimensions and Tolerances according to ISO 3547 and GSP-Specifications

Part No.	Nominal size		Length B	Wall thickness S <sub>3</sub>	Shaft-ø D <sub>J</sub> h8	Housing-ø D <sub>H</sub> H7	Bush i-ø D <sub>1a</sub> when ass. in H7 housing	Clearance C <sub>D</sub>	Oil hole-ø d <sub>L</sub>
	D <sub>i</sub>	D <sub>o</sub>							
PM 0808 HX	8	10	8.00	0.980 0.955	8.000 7.978	10.015 10.000	8.107 8.040	0.127 0.040	No hole
PM 0810 HX			9.50						
PM 0812 HX			12.00 11.50						
PM 1010 HX	10	12	10.25		10.000 9.978	12.018 12.000	10.110 10.040	0.135 0.040	3
PM 1012 HX			11.75						
PM 1015 HX			15.25 14.75						
PM 1020 HX	12	14	20.25 19.75		12.000 11.973	14.018 14.000	12.110 12.040	0.135 0.040	3
PM 1210 HX			10.25 9.75						
PM 1212 HX			12.25 11.75						
PM 1215 HX	14	16	15.25 14.75		14.000 13.973	16.018 16.000	14.110 14.040	0.135 0.040	4
PM 1220 HX			20.25 19.75						
PM 1225 HX			25.25 24.75						
PM 1415 HX	15	17	15.25 14.75		15.000 14.973	17.018 17.000	15.108 15.040	0.135 0.040	4
PM 1420 HX			20.25 19.75						
PM 1425 HX			25.25 24.75						
PM 1510 HX	15	17	10.25 9.75	15.000 14.973	17.018 17.000	15.108 15.040	0.135 0.040	4	
PM 1512 HX			12.25 11.75						
PM 1515 HX			15.25 14.75						
PM 1525 HX			25.25 24.75						

### ID and OD chamfers

S <sub>3</sub>	C <sub>0</sub>	C <sub>1</sub>	S <sub>3</sub>	C <sub>0</sub>	C <sub>1</sub>
0.75	max. 0.3*	max. 0.3*	2	1.2 ± 0.4	0.4 ± 0.3
1	0.6 ± 0.4	max. 0.4*	2.5	1.8 ± 0.6	0.6 ± 0.4
1.5	0.6 ± 0.4	0.4 ± 0.3*			

\* alternatively rounded

All dimensions in mm

**10 Standard Products**

Part No.	Nominal size		Length B		Wall thickness S <sub>3</sub>	Shaft-ø D <sub>J</sub> h8	Housing-ø D <sub>H</sub> H7	Bush i-ø D <sub>1a</sub> when ass. in H7 housing	Clearance C <sub>D</sub>	Oil hole-ø d <sub>L</sub>			
	D <sub>i</sub>	D <sub>o</sub>	max. min.	max. min.	max. min.	max. min.	max. min.	max. min.					
PM 1615 HX	16	18	15.25	0.980	16.000	18.018	16.110	0.135	4				
PM 1620 HX			14.75							19.75	16.040		
PM 1625 HX			25.25							24.75	16.040		
PM 1815 HX	18	20	15.25	0.955	18.000	20.021	18.111	0.040					
PM 1820 HX			14.75							19.75	18.040		
PM 1825 HX			25.25							24.75	18.040		
PM 2010 HX	20	23	10.25	1.475	20.000	23.021	20.131	0.164		6			
PM 2015 HX			9.75								14.75	19.967	20.050
PM 2020 HX			15.25								19.75	23.000	20.050
PM 2025 HX			14.75								24.75	23.000	20.050
PM 2030 HX			25.25								29.75	23.000	20.050
PM 2215 HX	22	25	15.25	1.445	22.000	25.021	22.131	0.050					
PM 2220 HX			14.75						19.75		21.967	22.050	
PM 2225 HX			25.25						24.75		25.000	22.050	
PM 2230 HX			30.25						29.75		25.000	22.050	
PM 2415 HX	24	27	15.25	1.970	24.000	27.021	24.131	0.188					
PM 2420 HX			14.75						19.75		23.967	24.050	
PM 2425 HX			25.25						24.75		27.000	24.050	
PM 2430 HX			30.25						29.75	27.000	24.050		
PM 2515 HX	25	28	15.25	1.935	25.000	28.021	25.131	0.060					
PM 2520 HX			14.75						19.75	24.967	25.050		
PM 2525 HX			25.25						24.75	28.000	25.050		
PM 2530 HX			30.25						29.75	28.000	25.050		
PM 2830 HX	28	31	30.25	1.970	28.000	31.025	28.131	0.188					
PM 2820 HX		32	29.75			27.967	31.000		28.050				
PM 2825 HX			20.25			24.75	32.025		28.155				
PM 2830 HX			19.75			24.75	32.000		28.060				
PM 3020 HX	30	34	20.25	1.935	30.000	34.025	30.155	0.060					
PM 3030 HX			19.75						29.75	34.000	30.060		
PM 3040 HX			30.25						29.75	34.000	30.060		

All dimensions in mm

Part No.	Nominal size		Length B	Wall thickness S <sub>3</sub>	Shaft-ø D <sub>J</sub> h8	Housing-ø D <sub>H</sub> H7	Bush i-ø D <sub>1a</sub> when ass. in H7 housing	Clearance C <sub>D</sub>	Oil hole-ø d <sub>L</sub>	
	D <sub>1</sub>	D <sub>0</sub>								max. min.
PM 3220 HX	32	36	20.25	1.970 1.935	32.000 31.961	36.025 36.000	32.155 32.060	0.194 0.060	6	
PM 3230 HX			19.75							30.25
PM 3235 HX			29.75							35.25
PM 3240 HX			34.75							40.25
PM 3520 HX	35	39	20.25		35.000 34.961	39.025 39.000	35.155 35.060			
PM 3530 HX			19.75							30.25
PM 3535 HX			29.75							35.25
PM 3550 HX			34.75							50.25
PM 3635 HX	36	40	39.75		36.000 35.961	40.025 40.000	36.155 36.060			
PM 3720 HX	37	41	20.25		37.000 36.961	41.025 41.000	37.155 37.060			
PM 4020 HX	40	44	20.25		40.000 39.961	44.025 44.000	40.155 40.060			
PM 4030 HX			19.75							30.25
PM 4040 HX			29.75							40.25
PM 4050 HX			39.75							50.25
PM 4520 HX	45	50	20.25		45.000 44.961	50.025 50.000	45.195 45.080			
PM 4530 HX			19.75							30.25
PM 4540 HX			29.75	40.25						
PM 4545 HX			39.75	45.25						
PM 4550 HX	44.75	50.25								
PM 5040 HX	50	55	49.75	50.000 49.961	55.030 55.000	50.200 50.080				
PM 5050 HX			60.25				60.25			
PM 5060 HX			59.75				20.25			
PM 5520 HX	55	60	19.75	2.460 2.415	55.000 54.954	60.030 60.000	55.200 55.080			
PM 5525 HX			24.75					25.25		
PM 5530 HX			29.75					30.25		
PM 5540 HX			39.75					40.25		
PM 5550 HX			49.75					50.25		
PM 5560 HX			59.75					60.25		
PM 6030 HX	60	65	29.75	60.000 59.954	65.030 65.000	60.200 60.080				
PM 6040 HX			39.75				40.25			
PM 6060 HX			59.75				60.25			
PM 6070 HX			69.75				70.25			

All dimensions in mm

# 10 Standard Products

Part No.	Nominal size		Length B	Wall thickness S <sub>3</sub>	Shaft-ø D <sub>J</sub> h8	Housing-ø D <sub>H</sub> H7	Bush i-ø D <sub>1a</sub> when ass. in H7 housing	Clearance C <sub>D</sub>	Oil hole-ø d <sub>L</sub>	
	D <sub>i</sub>	D <sub>o</sub>	max. min.	max. min.	max. min.	max. min.	max. min.	max. min.		
PM 6540 HX	65	70	40.25	2.450 2.384	65.000 64.954	70.030 70.000	65.262 65.100	0.308 0.100	8	
PM 6550 HX			39.75							50.25
PM 6560 HX			49.75							60.25
PM 6570 HX			59.75							70.25
PM 7040 HX	70	75	69.75		70.000 69.954	75.030 75.000	70.262 70.100			
PM 7050 HX			40.25							
PM 7065 HX			39.75							50.25
PM 7070 HX			49.75							65.25
PM 7080 HX	64.75	70.25								
PM 7540 HX	75	80	69.75		75.000 74.954	80.030 80.000	75.262 75.100			
PM 7560 HX			40.25							
PM 7580 HX			39.75					60.25		
PM 8040 HX	80	85	59.75		80.000 79.954	85.035 85.000	80.267 80.100	0.313 0.100		
PM 8060 HX			40.50							
PM 8080 HX			39.50							60.50
PM 80100 HX			59.50							80.50
PM 8530 HX	85	90	79.50		85.000 84.946	90.035 90.000	85.267 85.100			
PM 8540 HX			100.50							
PM 8560 HX			99.50							60.50
PM 8580 HX			59.50							80.50
PM 85100 HX			79.50	100.50						
PM 9040 HX	90	95	99.50	90.000 89.946	95.035 95.000	90.267 90.100	0.321 0.100			
PM 9060 HX			40.50							
PM 9080 HX			39.50					60.50		
PM 9090 HX			59.50					80.50		
PM 90100 HX			79.50					90.50		
PM 9560 HX	95	100	89.50	95.000 94.946	100.035 100.000	95.267 95.100				
PM 95100 HX			99.50					100.50		

All dimensions in mm

Part No.	Nominal size		Length B	Wall thickness S <sub>3</sub>	Shaft-ø D <sub>J</sub> h8	Housing-ø D <sub>H</sub> H7	Bush i-ø D <sub>1a</sub> when ass. in H7 housing	Clearance C <sub>D</sub>	Oil hole-ø d <sub>L</sub>
	D <sub>1</sub>	D <sub>0</sub>							
PM 10050 HX	100	105	50.50	2.450 2.384	100.000 99.946	105.035 105.000	100.267 100.100	9.5	
PM 10060 HX			49.50						
PM 10080 HX			60.50						
PM 10095 HX			59.50						
PM 100115HX			80.50						
	79.50								
	95.50								
	94.50								
	115.50								
	114.50								
PM 10560 HX	105	110	60.50		105.000 104.946	110.035 110.000	105.267 105.100		
PM 105110 HX			59.50						
PM 105115 HX			110.50						
	109.50								
	115.50								
	114.50								
PM 11060 HX	110	115	60.50	110.000 109.946	115.035 115.000	110.267 105.100			
PM 110110 HX			59.50						
PM 110115 HX			110.50						
	109.50								
	115.50								
	114.50								
PM 11550 HX	115	120	50.50	115.000 114.946	120.035 120.000	115.267 115.100			
PM 11570 HX			49.50						
PM 12060 HX			70.50						
	69.95								
	60.50								
	59.50								
PM 120100 HX	120	125	100.50	120.000 119.946	125.040 125.000	120.272 120.100			
PM 120110 HX			99.50						
PM 12560 HX			110.50						
	109.50								
	60.50								
	59.50								
PM 125100 HX	125	130	100.50	125.000 124.937	130.040 130.000	125.272 125.100			
PM 125110 HX			99.50						
PM 13050 HX			110.50						
	109.50								
	50.50								
	49.50								
PM 13060 HX	130	135	60.50	130.000 129.937	135.040 135.000	130.280 130.130			
PM 13080 HX			59.50						
PM 130100 HX			80.50						
			79.50						
	100.50								
	99.50								
PM 13560 HX	135	140	60.50	135.000 134.937	140.040 140.000	135.280 135.130			
PM 13580 HX			59.50						
PM 14050 HX			80.50						
	79.50								
	50.50								
	49.50								
PM 14060 HX	140	145	60.50	140.000 139.937	145.040 145.000	140.280 140.130			
PM 14080 HX			59.50						
PM 140100 HX			80.50						
			79.50						
	100.50								
	99.50								
PM 15050 HX	150	155	50.50	150.000 149.937	155.040 155.000	150.280 150.130			
PM 15060 HX			49.50						
PM 15080 HX			60.50						
			59.50						
PM 150100 HX			80.50						
	79.50								
	100.50								
	99.50								

All dimensions in mm

**10 Standard Products**

Part No.	Nominal size		Length B	Wall thickness S <sub>3</sub>	Shaft-ø D <sub>J</sub> h8	Housing-ø D <sub>H</sub> H7	Bush i-ø D <sub>1a</sub> when ass. in H7 housing	Clearance C <sub>D</sub>	Oil hole-ø d <sub>L</sub>	
	D <sub>I</sub>	D <sub>O</sub>								max. min.
PM 16050 HX	160	165	50.50	2.435 2.380	160.000 159.937	165.040 165.000	160.280 160.130	0.343 0.130	-	
PM 16060 HX			49.50							60.50
PM16080 HX			59.50							80.50
PM 160100 HX			79.50							100.50
PM 17050 HX	170	175	99.50		170.000 169.937	175.040 175.000	170.280 170.130			
PM 17060 HX			50.50							60.50
PM 17080 HX			59.50							80.50
PM 170100 HX			79.50							100.50
PM 18050 HX	180	185	99.50		180.000 179.937	185.046 185.000	180.286 180.130			
PM 18060 HX			50.50							60.50
PM 18080 HX			59.50							80.50
PM 180100 HX			79.50							100.50
PM 19050 HX	190	195	99.50		190.000 189.928	195.046 195.000	190.286 190.130			
PM 19060 HX			50.50							60.50
PM 19080 HX			59.50							80.50
PM 190100 HX			79.50							100.50
PM 190120 HX			120.50 19.50							
PM 20050 HX	200	205	50.50		200.000 199.928	205.046 205.000	200.286 200.130			
PM 20060 HX			49.50							60.50
PM 20080 HX			59.50							80.50
PM 200100 HX			79.50							100.50
PM 200120 HX			99.50 120.50 119.50							
PM 22050 HX	220	225	50.50		220.000 219.928	225.046 225.000	220.286 220.130			
PM 22060 HX			49.50							60.50
PM 22080 HX			59.50	80.50						
PM 220100 HX			79.50	100.50						
PM 220120 HX			99.50 120.50 119.50							
PM 24050 HX	240	245	50.50	240.000 239.928	245.046 245.000	240.286 240.130				
PM 24060 HX			49.50				60.50			
PM 24080 HX			59.50				80.50			
PM 240100 HX			79.50				100.50			
PM 240120 HX			99.50 120.50 119.50							

All dimensions in mm

Part No.	Nominal size		Length B	Wall thickness S <sub>3</sub>	Shaft-ø D <sub>J</sub> h8	Housing-ø D <sub>H</sub> H7	Bush i-ø D <sub>1a</sub> when ass. in H7 housing	Clearance C <sub>D</sub>	Oil hole-ø d <sub>L</sub>
	D <sub>1</sub>	D <sub>0</sub>	max. min.	max. min.	max. min.	max. min.	max. min.	max. min.	
PM 25050 HX	250	255	50.50	2.435 2.380	250.000 249.928	255.052 255.000	250.292 250.130	0.364 0.130	
PM 25060 HX			49.50						
PM 25080 HX			60.50						
PM 250100 HX			59.50						
PM 250120 HX			80.50						
PM 26050 HX	260	265	79.50		260.000 259.919	265.052 265.000	260.292 260.130		
PM 26060 HX			50.50						
PM 26080 HX			49.50						
PM 260100 HX			60.50						
PM 260120 HX			59.50						
PM 28050 HX	280	285	80.50		280.000 279.919	285.052 285.000	280.292 280.130	0.373 0.130	
PM 28060 HX			50.50						
PM 28080 HX			49.50						
PM 280100 HX			60.50						
PM 280120 HX			59.50						
PM 30050 HX	300	305	80.50	300.000 299.919	305.052 305.000	300.292 300.130			
PM 30060 HX			50.50						
PM 30080 HX			49.50						
PM 300100 HX			60.50						
PM 300120 HX			59.50						

All dimensions in mm



10 Standard Products

10.2MB-HX cylindrical bushes

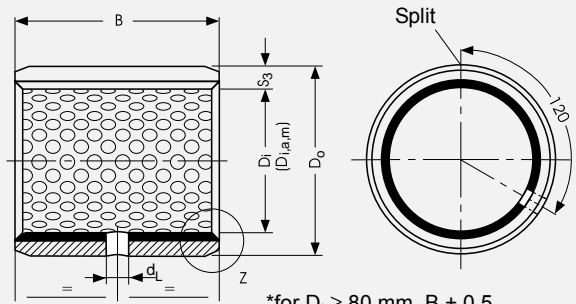
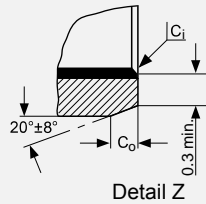

\*for  $D_i \geq 80$  mm,  $B \pm 0.5$

Dimensions and Tolerances according to ISO 3547 and GSP-Specifications

Part No.	Nominal size		Length B	Wall thickness $S_3$	Shaft- $\varnothing$ $D_J$ [h8]	Housing- $\varnothing$ $D_H$ [H7]	Bush I- $\varnothing$ $D_{1m}$ machined to H7	Clearance $C_D$	Oil hole- $\varnothing$ $d_L$
	$D_i$	$D_o$							
MB 0808 HX	8	10	8.00	1.108 1.082	7.960 7.938	10.015 10.000	8.015 8.000	0.077 0.040	No hole
MB 0810 HX			10.00						
MB 0812 HX			12.00						
MB 1010 HX	10	12	10.25		9.960 9.938	12.018 12.000	10.015 10.000		
MB 1012 HX			12.25						
MB 1015 HX			15.25						
MB 1020 HX			20.25						
MB 1210 HX	12	14	10.25		11.950 11.923	14.018 14.000	12.018 12.000	0.095 0.050	3
MB 1212 HX			12.25						
MB 1215 HX			15.25						
MB 1220 HX			20.25						
MB 1225 HX			25.25						
MB 1415 HX	14	16	15.25		13.950 13.923	16.018 16.000	14.018 14.000	4	
MB 1420 HX			20.25						
MB 1425 HX			25.25						
MB 1510 HX	15	17	10.25	14.950 14.923	17.018 17.000	15.018 15.000	4		
MB 1512 HX			12.25						
MB 1515 HX			15.25						
MB 1520 HX			20.25						
MB 1525 HX			25.25						

ID and OD chamfers

$S_3$	$C_o$	$C_i$	$S_3$	$C_o$	$C_i$
0.75	max. 0.3*	max. 0.3*	2	$1.2 \pm 0.4$	$0.4 \pm 0.3$
1	$0.6 \pm 0.4$	max. 0.4*	2.5	$1.8 \pm 0.6$	$0.6 \pm 0.4$
1.5	$0.6 \pm 0.4$	$0.4 \pm 0.3^*$			

\* alternatively rounded

All dimensions in mm

Part No.	Nominal size		Length B	Wall thickness S <sub>3</sub>	Shaft-ø D <sub>J</sub> [h8]	Housing-ø D <sub>H</sub> [H7]	Bush i-ø D <sub>1m</sub> machined to H7	Clearance C <sub>D</sub>	Oil hole-ø d <sub>L</sub>	
	D <sub>1</sub>	D <sub>0</sub>								max. min.
MB 1615 HX	16	18	15.25	1.108 1.082	15.950 15.923	18.018 18.000	16.018 16.000	0.095 0.050	4	
MB 1620 HX			14.75							20.25
MB 1625 HX			19.75							25.25
MB 1815 HX	18	20	15.25		17.950 17.923	20.021 20.000	18.018 18.000			
MB 1820 HX			14.75							20.25
MB 1825 HX			19.75							25.25
MB 2010 HX	20	23	10.25	1.608 1.576	19.935 19.902	23.021 23.000	20.021 20.000	0.119 0.065		
MB 2015 HX			9.75							15.25
MB 2020 HX			14.75							20.25
MB 2025 HX			19.75							25.25
MB 2030 HX			24.75							30.25
MB 2215 HX	22	25	29.75		21.935 21.902	25.021 25.000	22.021 22.000			
MB 2220 HX			15.25						20.25	
MB 2225 HX			14.75						25.25	
MB 2230 HX			19.75						30.25	
MB 2415 HX	24	27	14.75		23.935 23.902	27.021 27.000	24.021 24.000			
MB 2420 HX			15.25	20.25						
MB 2425 HX			19.75	25.25						
MB 2430 HX			24.75	30.25						
MB 2515 HX	25	28	14.75	24.935 24.902	28.021 28.000	25.021 25.000				
MB 2520 HX			15.25				20.25			
MB 2525 HX			19.75				25.25			
MB 2530 HX			24.75				30.25			
MB 2820 HX	28	32	20.25	2.108 2.072	27.935 27.902	32.025 32.000	28.021 28.000			
MB 2825 HX			19.75					25.25		
MB 2830 HX			14.75					24.75		
MB 3020 HX	30	34	29.75		30.000 29.967	34.025 34.000		30.021 30.000		
MB 3030 HX			20.25						30.25	
MB 3040 HX			19.75						29.75	
			39.75							

All dimensions in mm

# 10 Standard Products

Part No.	Nominal size		Length B		Wall thickness S <sub>3</sub>	Shaft-ø D <sub>J</sub> [h8]	Housing-ø D <sub>H</sub> [H7]	Bush i-ø D <sub>1m</sub> machined to H7	Clearance C <sub>D</sub>	Oil hole-ø d <sub>L</sub>		
	D <sub>i</sub>	D <sub>o</sub>	max. min.	max. min.	max. min.	max. min.	max. min.	max. min.				
MB 3220 HX	32	36	20.25	2.108 2.072	31.920 31.881	36.025 36.000	32.025 32.000	0.144 0.080	6			
MB 3230 HX			29.75									
MB 3235 HX			35.25									
MB 3240 HX			40.25									
MB 3520 HX	35	39	20.25							34.920	39.025	35.025
MB 3530 HX			29.75							34.881	39.000	35.000
MB 3550 HX			50.25									
MB 3720 HX	37	41	20.25							36.920	41.025	37.025
MB 4020 HX	40	44	19.75		36.881	41.000	37.000					
MB 4030 HX			20.25		44.920 44.881	50.025 50.000	45.025 45.000					
MB 4030 HX			29.75									
MB 4040 HX			40.25									
MB 4050 HX	49.75											
MB 4520 HX	45	50	19.75		2.634 2.588	49.920 49.881	55.030 55.000			50.025 50.000	0.176 0.100	8
MB 4530 HX			30.25									
MB 4540 HX			39.75									
MB 4545 HX			45.25									
MB 4550 HX			49.75									
MB 5040 HX	50	55	40.25	54.900 54.854		60.030 60.000	55.030 55.000					
MB 5060 HX			59.75									
MB 5520 HX			20.25									
MB 5525 HX	55	60	19.75	59.900 59.854		65.030 65.000	60.030 60.000					
MB 5530 HX			25.25									
MB 5540 HX			24.75									
MB 5550 HX			30.25									
MB 5560 HX			29.75									
MB 6030 HX			60		65			40.25				
MB 6040 HX	39.75											
MB 6060 HX	60.25											
MB 6070 HX	59.75											
MB 6070 HX	70.25											
			69.75									

All dimensions in mm

Part No.	Nominal size		Length B	Wall thickness S <sub>3</sub>	Shaft-ø D <sub>J</sub> [h8]	Housing-ø D <sub>H</sub> [H7]	Bush i-ø D <sub>1m</sub> machined to H7	Clearance C <sub>D</sub>	Oil hole-ø d <sub>L</sub>	
	D <sub>1</sub>	D <sub>0</sub>								max. min.
MB 6540 HX	65	70	40.25	2.634 2.568	64.900 64.854	70.030 70.000	65.030 65.000	0.176 0.100	8	
MB 6550 HX			39.75							50.25
MB 6560 HX			49.75							60.25
MB 6570 HX			59.75							70.25
MB 7040 HX	70	75	69.75		69.900 69.854	75.030 75.000	70.030 70.000			
MB 7050 HX			40.25							
MB 7065 HX			39.75							65.25
MB 7070 HX			49.75							64.75
MB 7080 HX	70.25	69.75								
MB 7540 HX	75	80	80.25		74.900 74.854	80.030 80.000	75.030 75.000			
MB 7560 HX			40.25							
MB 7580 HX			39.75							60.25
MB 8040 HX	80	85	59.75		79.900 79.854	85.035 85.000	80.030 80.000			
MB 8060 HX			40.25							
MB 8080 HX			39.50					60.50		
MB 80100 HX			59.50					80.50		
MB 8530 HX	85	90	79.50		84.880 84.826	90.035 90.000	85.035 85.000			
MB 8540 HX			100.50							
MB 8560 HX			99.50					60.50		
MB 8580 HX			59.50					80.50		
MB 85100 HX			79.50					100.50		
MB 9040 HX	90	95	99.50		89.880 89.826	95.035 95.000	90.035 90.000			
MB 9060 HX			40.50							
MB 9090 HX			39.50					60.50		
MB 90100 HX			59.50					90.50		
MB 9560 HX	95	100	89.50		94.880 94.826	100.035 100.000	95.035 95.000			
MB 95100 HX			100.50							
MB 10050 HX	100	105	99.50		99.880 99.826	105.035 105.000	100.035 100.000			
MB 10060 HX			50.50							
MB 10080 HX			49.50	60.50						
MB 10095 HX			59.50	80.50						
MB 100115HX			79.50	95.50						
			94.50	115.50						

All dimensions in mm

# 10 Standard Products

Part No.	Nominal size		Length B	Wall thickness S <sub>3</sub>	Shaft-ø D <sub>J</sub> [h8]	Housing-ø D <sub>H</sub> [H7]	Bush i-ø D <sub>1m</sub> machined to H7	Clearance C <sub>D</sub>	Oil hole-ø d <sub>L</sub>		
	D <sub>i</sub>	D <sub>o</sub>								max. min.	max. min.
MB 10560 HX	105	110	60.50	2.634 2.568	104.880 104.826	110.035 110.000	105.035 105.000	0.209 0.120	9.5		
MB 105110 HX			59.50							110.50	
MB 105115 HX			109.50							115.50	
MB 11060 HX	110	115	114.50		109.880	115.035	110.035				
MB 110115 HX			59.50		115.50	109.826	115.000			105.000	
MB 11550 HX	115	120	114.50		114.880	120.035	115.035				
MB 11570 HX			50.50		114.826	120.000	115.000				
MB 12060 HX	120	125	49.50		119.880	125.040	120.035				
MB 120100 HX			70.50		119.826	125.000	120.000				
MB 125100 HX	125	130	69.95		124.855	130.040	125.040				
MB 13050 HX	130	135	99.50	2.619 2.564	129.855 129.792	135.040 135.000	130.040 130.000	0.248 0.145	-		
MB 13060 HX			50.50							100.50	
MB 130100 HX			49.50							99.50	
MB 13560 HX	135	140	80.50	134.855	140.040	135.040					
MB 13580 HX			79.50	134.792	140.000	135.000					
MB 14060 HX	140	145	60.50	139.855	145.040	140.040					
MB 140100 HX			59.50	139.792	145.000	140.000					
MB 15060 HX	150	155	100.50	149.855 149.792	155.040 155.000	150.040 150.000					
MB 15080 HX			60.50								80.50
MB 150100 HX			59.50								79.50

All dimensions in mm

### 10.3HX Thrust Washers

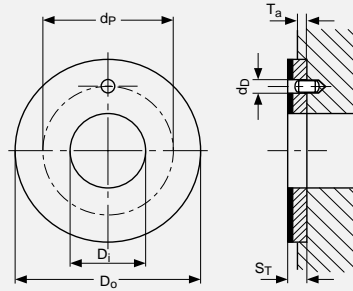
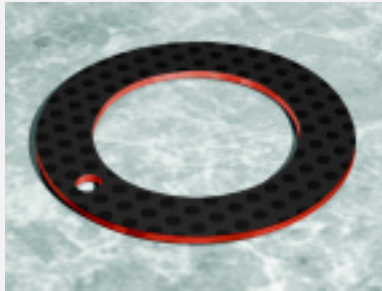

Part No.	Inside- $\varnothing$ $D_i$	Outside- $\varnothing$ $D_o$	Thickness $S_T$	Dowel hole PCD- $\varnothing$ $d_p$	Dowel hole- $\varnothing$ $d_D$	Recess depth $T_a$
	max. min.	max. min.	max. min.	max. min.	max. min.	max. min.
WC10HX	12.25 12.00	24.00 23.75	1.577 1.487	18.12 17.88	1.875 1.625	1.20 0.95
WC12HX	14.25 14.00	26.00 25.75		20.12 19.88	2.375 2.125	
WC14HX	16.25 16.00	30.00 29.75		22.12 21.88		
WC16HX	18.25 18.00	32.00 31.75		25.12 24.88		
WC18HX	20.25 20.00	36.00 35.75		28.12 27.88	3.375 3.125	
WC20HX	22.25 22.00	38.00 37.75		30.12 29.88		
WC22HX	24.25 24.00	42.00 41.75		33.12 32.88	4.375 4.125	
WC24HX	26.25 26.00	44.00 43.75		35.12 34.88		
WC25HX	28.25 28.00	48.00 47.75		38.12 37.88		
WC30HX	32.25 32.00	54.00 53.75		43.12 42.88		
WC35HX	38.25 38.00	62.00 61.75		50.12 49.88		
WC40HX	42.25 42.00	66.00 65.75		54.12 53.88		
WC45HX	48.25 48.00	74.00 73.75		61.12 60.88	1.70 1.45	
WC50HX	52.25 52.00	78.00 77.75		65.12 64.88		

All dimensions in mm

10 Standard Products

10.4HX Strip

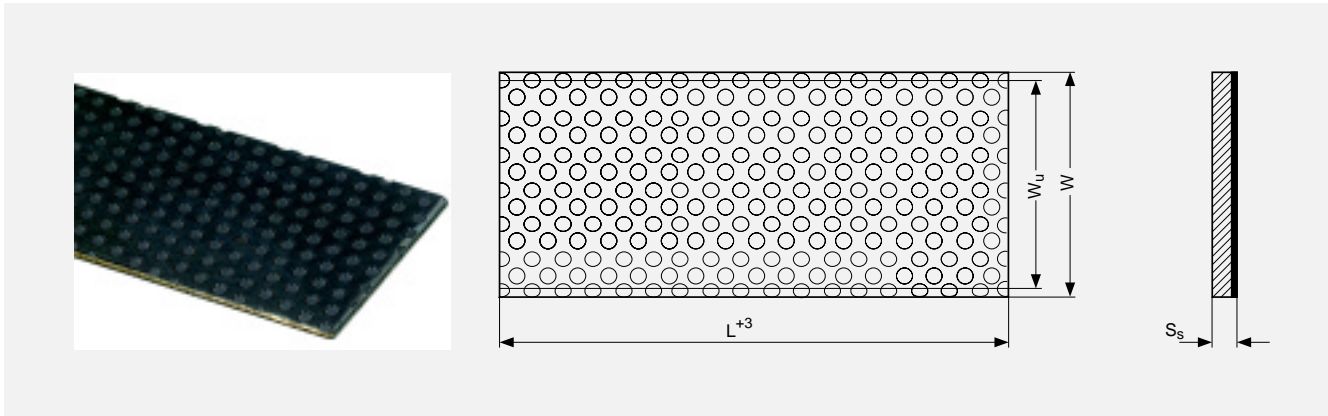

Group No.	Length L	Total width W	Usable Width W <sub>u</sub>	Thickness S <sub>s</sub>	
				max.	min.
S100 90 HX	500	102	93	1.07	1.03
S152 00 HX		210	200	1.56	1.52
S202 00 HX		227	218	2.05	2.01
S252 00 HX				2.57	2.52

All dimensions in mm

Glacier Garlock Bearings warrants that products described in this brochure are free from defects in workmanship and material but unless expressly agreed in writing Glacier Garlock Bearings gives no warranty that these products are suitable for any particular purpose of for use under any specific conditions notwithstanding that such purpose would appear to be covered by this publication. Glacier Garlock Bearings accepts no liability for any loss, damage, or expense whatsoever arising directly or indirectly from use of its products. All business undertaken by Glacier Garlock Bearings is subject to its standard Conditions of Sale, copies of which are available upon request. Glacier Garlock Bearings products are subject to continual development and Glacier Garlock Bearings reserves the right to make changes in the specification and design of its products without prior notice.

GLACIER<sup>TM</sup> is a Trademark of the EnPro Industries Inc., USA.

Hi-eX<sup>TM</sup> is a Trademark of the EnPro Industries Inc., USA.

DS<sup>TM</sup> is a Trademark of the EnPro Industries Inc., USA.