

the **precision** benchmark

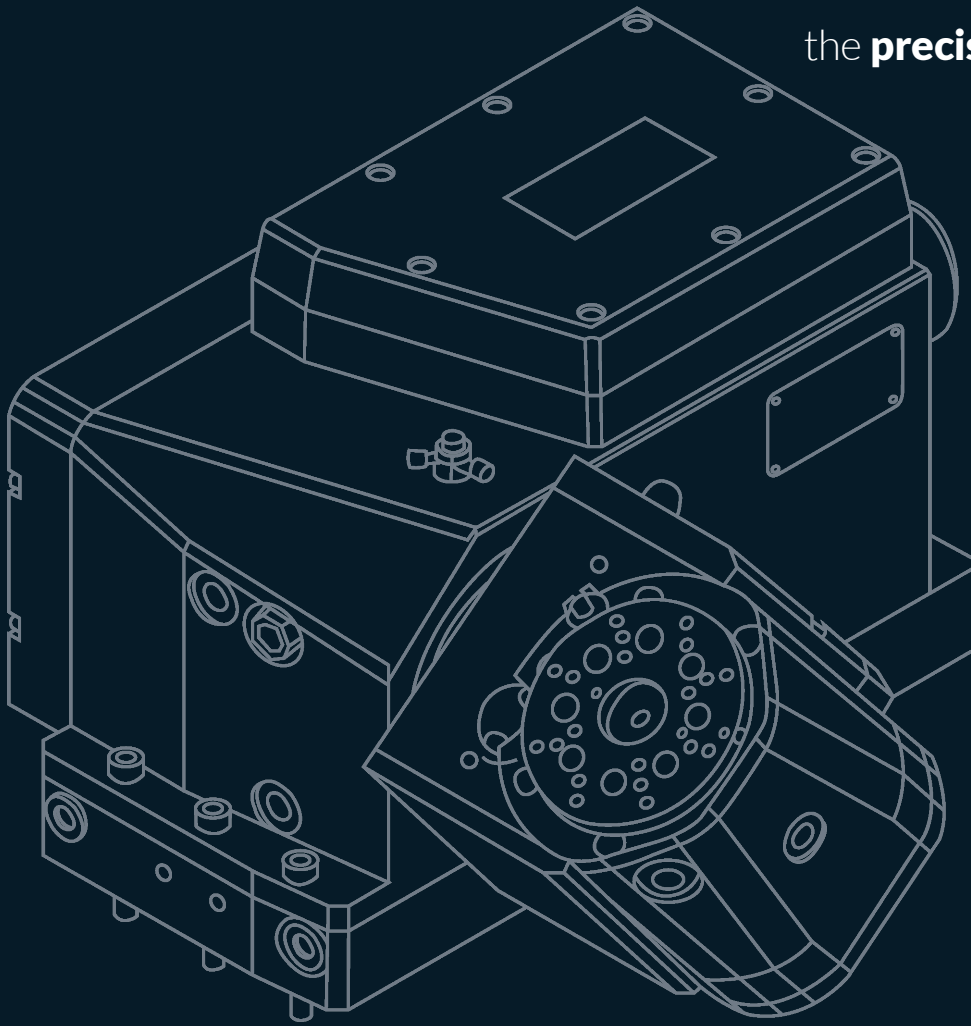

# Rotary Indexing Tables and Rotating Spindles

For high-precise and complex indexing

**CARL  
HIRSCH  
MANN** 

EN1937

## Sample Applications



### Sinking EDM

- Undercuts
- Tooth systems
- Perforations

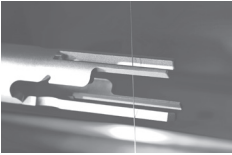

### Wire EDM

- Curved shapes
- Spirals
- Complex shapes

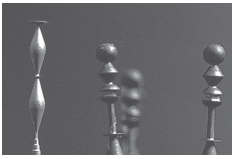

### Erosive turning

- Ejector pins
- Finest needles
- Complex shapes



### EDM drilling

- Parts with multiple hole pattern
- Single, precise holes
- Start hole drilling

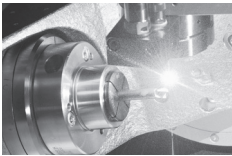

### Laser machining

- Channels in fuel injectors
- Turbine blades
- Surgical instruments

## Specifications

- Uniaxial rotary indexing tables
- Multi-axial rotary indexing tables
- Rotary indexing tables with hollow axle
- Rotating and indexing spindles
- Customized special solutions
- If requested, all rotary indexing tables can be equipped with a precise clamping system.

## Common characteristics

- Completely sealed (IP68) for use in dielectric fluid
- Maintenance-free, patented EDM power transmission for wire EDM
- Maintenance-free AC drive
- Applicable on any EDM, laser oder HSC machine
- Hirgh-precise direct measuring systems

## Control system of Rotary Indexing Table

Preferably rotary indexing table is controlled by machine control system. If this is not possible, we recommend control system H1625.

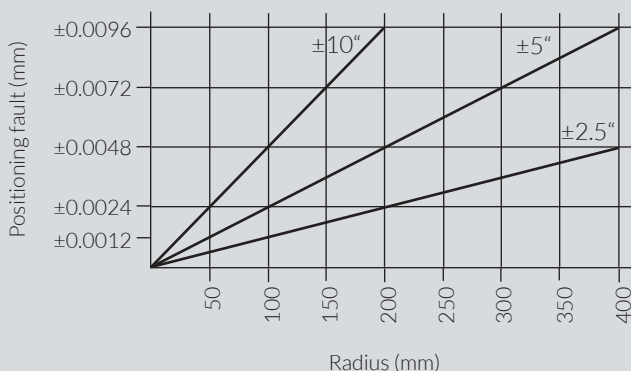

## Position and indexing accuracy

Positioning or indexing accuracy is mainly depending on accuracy of measuring system (encoder) and on precision of mechanical construction and control system. The influence of system accuracy of encoder can be seen in the table (on the left).

Example: at an encoder system accuracy of  $\pm 5''$  and a radius of 100 mm positioning fault (direct) is max.  $\pm 0,0024$  mm. It is recommended to use a measuring system with higher accuracy for larger rotary indexing tables or workpiece diameters.



## Any shape is possible

With Carl Hirschmann Rotary Indexing Tables shapes and structures can be realized, that seemed to be unimaginable up to now.

Using a Rotary Indexing Table for wire and sinking EDM shapes can be machined that are far beyond the possibilities of turning, grinding and milling operations.

## Individual special solutions

Do you have special requirements concerning a rotary indexing axis? Together with you our specialists can develop an individual solution for your problem.

## Maintenance-free EDM power transmission

With the patented maintenance-free Carl Hirschmann technology for transmission of EDM current through micro-fibre rings we are again on step ahead!

### Advantages

- Improved process stability
- Remains clean because it is integrated
- Maintenance-free
- Low friction

## Rotary Indexing Tables for EDM, HSC and laser machines

With decades of experience and sophisticated engineering we are the world's leading manufacturer of Rotary Indexing Tables and Rotating/Indexing Spindles including complete clamping technology for EDM and laser technology. Our main attention is on your individual request and together with you we will find the optimal solution.

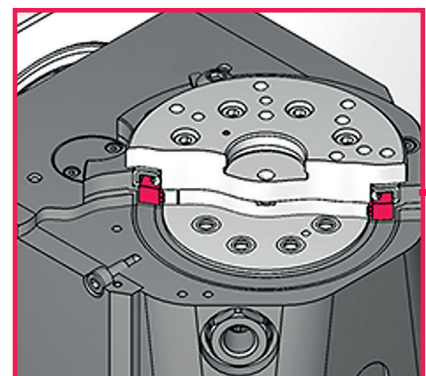
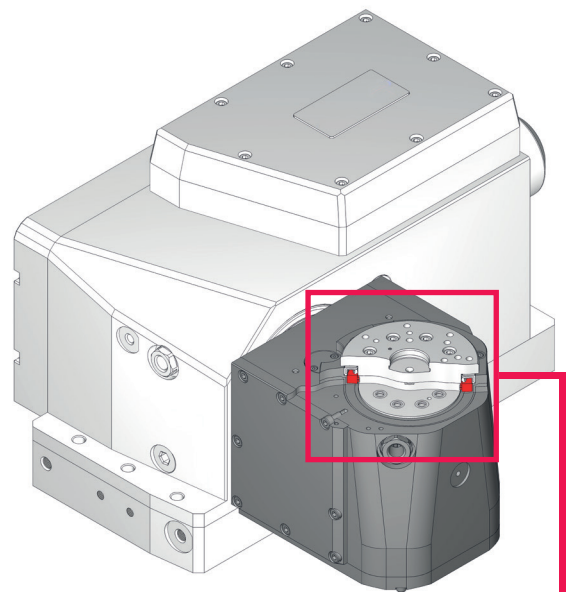

## Uni-axial Rotary Indexing Tables

At Carl Hirschmann all parts are homemade with high technical know-how and are assembled professionally to complete units consisting of rotary indexing table, palletizing and clamping system. With uniaxial rotary tables a vertical and horizontal machining with best positioning accuracy, concentricity and axial run-out accuracy is possible. If requested uniaxial rotary indexing tables can be delivered also with SK or HSK tapers.

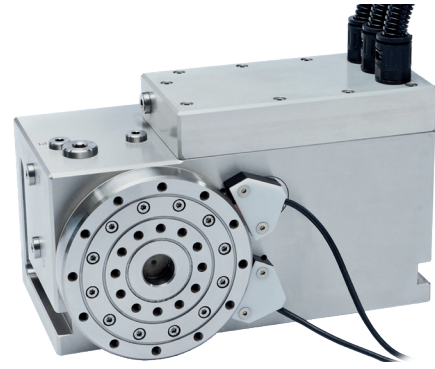

## Two-axial Rotary Indexing Tables

Our two-axial rotary indexing tables stand for highest precision, accuracy and continuity. The rotary tables allow machining processes in vertical and horizontal axis. For quick change of workpieces the two-axial rotary indexing tables can be equipped with a precise manual or pneumatic operated clamping system.

## Multi-axial Rotary Indexing Tables

Our multi-axial rotary indexing tables enable machining in for example three or up to five axes with optimal positioning accuracy, concentricity and axial run-out accuracy for workpieces. This rotating tables can be made for machining of materials in different sizes and weight. Multi-axial tables are customized: only by Carl Hirschmann the customer gets all out of one source. Beginning from conception followed by initial sampling up to product ready for serial production.

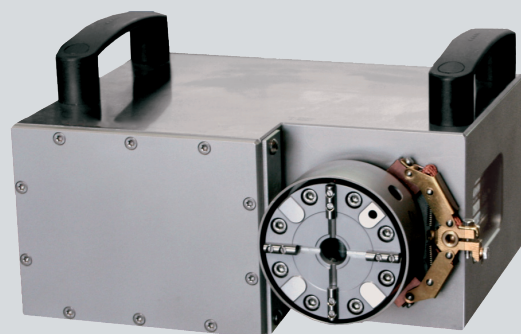
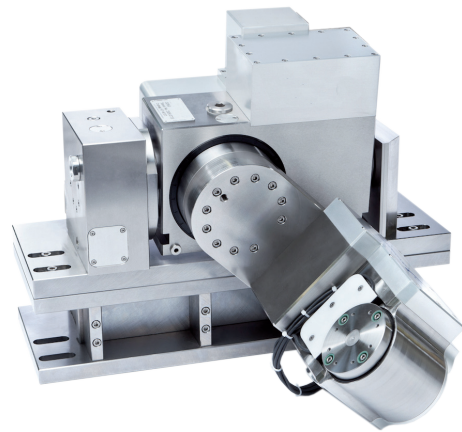

## Rotating and Indexing Spindles

Manufacturing of smallest rotationally symmetric structures and shapes out of stainless steel, hard and non-ferrous metals up to conductive ceramics or spark EDM machines equipped with rotating spindles is an alternative to hard turning.

## Hollow Axes

With our precise uniaxial and two-axial rotary indexing tables with hollow axle the workpiece can be machined up to its center. Wire EDM is possible also for small workpieces.

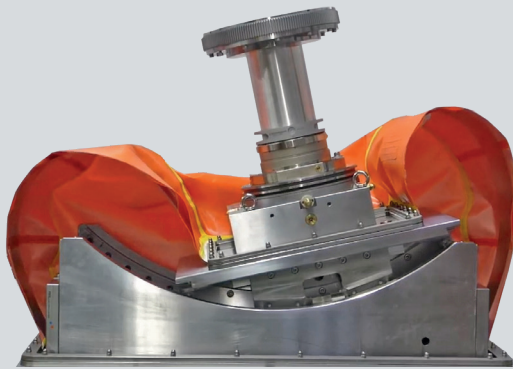
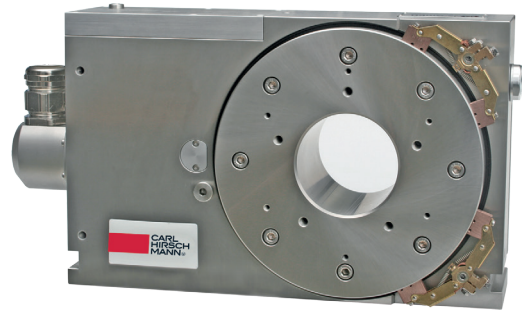

## Customized solutions

Due to our high manufacturing depth it is guaranteed to our customers that all components are made and not only assembled by Carl Hirschmann. We are pleased to meet individual customer requirements. Please contact us directly to find the perfect product for your demand.

# Carl Hirschmann - System provider with more than 40 years of experience

For more than 40 years Carl Hirschmann develops and produces rotary indexing tables with coordinated reference and clamping systems. Cost and time pressure in part machining on EDM are always new challenges for industry and commerce. A key to success lies in set-up times - who trusts in efficiency here can raise productivity. Innovate rotary indexing tables with coordinated reference and clamping systems optimize machine running times and improve economics.

As leader in technology Carl Hirschmann offers liquid-tight rotary indexing tables (IP68), A-axes, rotating and indexing spindles with complete clamping systems for EDM technology included. Due to high vertical range of manufacturing the customers approach only to one contact person and receive the guarantee that all components are not only assembled but made by Carl Hirschmann. Even for products which are in use for decades the company still offers suitable parts.

# CARL HIRSCH MANN®



## HEADQUARTER

**Carl Hirschmann GmbH**  
Kirchentannenstraße 9  
78737 Fluorn-Winzeln  
Germany

T +49 7402 183-0  
F +49 7402 183-10  
E [info@carlhirschmann.de](mailto:info@carlhirschmann.de)

## USA

**Carl Hirschmann, Inc.**  
165 East Commerce Drive  
Ste 104  
Schaumburg, IL 60173, USA

T +1 847 468 9700  
F +1 847 468 9701  
E [info@carlhirschmann.us](mailto:info@carlhirschmann.us)

## CHINA

**Carl Hirschmann**  
Room C528, Block 180,  
South Chang Jiang Road  
Bao Shan District, Shanghai  
P.R. CHINA 200433

T +86 139 16 13 58 45  
E [info@carlhirschmann.com.cn](mailto:info@carlhirschmann.com.cn)

[carlhirschmann.de](http://carlhirschmann.de)