



# Precision Positioning Table LH

# TSLH·CTLH

CAT-57114

*High rigidity series newly introduced !*





Super Large Size is included.

# HIGH RIGIDITY SERIES !

Table width 120•220•320•420mm



**IKO**

*Precision Positioning Table LH*

# TSLH·CTLH

<Single axis specification>

<Two axis specification>

**Stable Running Accuracy**

**High Positioning Accuracy**

**Large Loading Weight**



# **IKO Precision Positioning Table LH**

## **TSLH·CTLH**

IKO Precision Positioning Table LH is a positioning table, featuring high reliability, high accuracy, and high rigidity. IKO Linear Ways are assembled on a slide table and bed made of cast iron which are designed to have high rigidity and superior vibration damping characteristics, and a precision ball screw is assembled in the drive mechanism. With the parallel arrangement of two sets of Linear Ways, this table provides stable and high running accuracy and positioning accuracy, as well as a high load capacity.

Four sizes with table widths ranging from 120 mm to super large size 420 mm are available. Two axis tables which combine these single axis tables are also available as standard specification. This product is most suitable for use as a high accuracy positioning mechanism with a large applied load and a relatively long stroke.

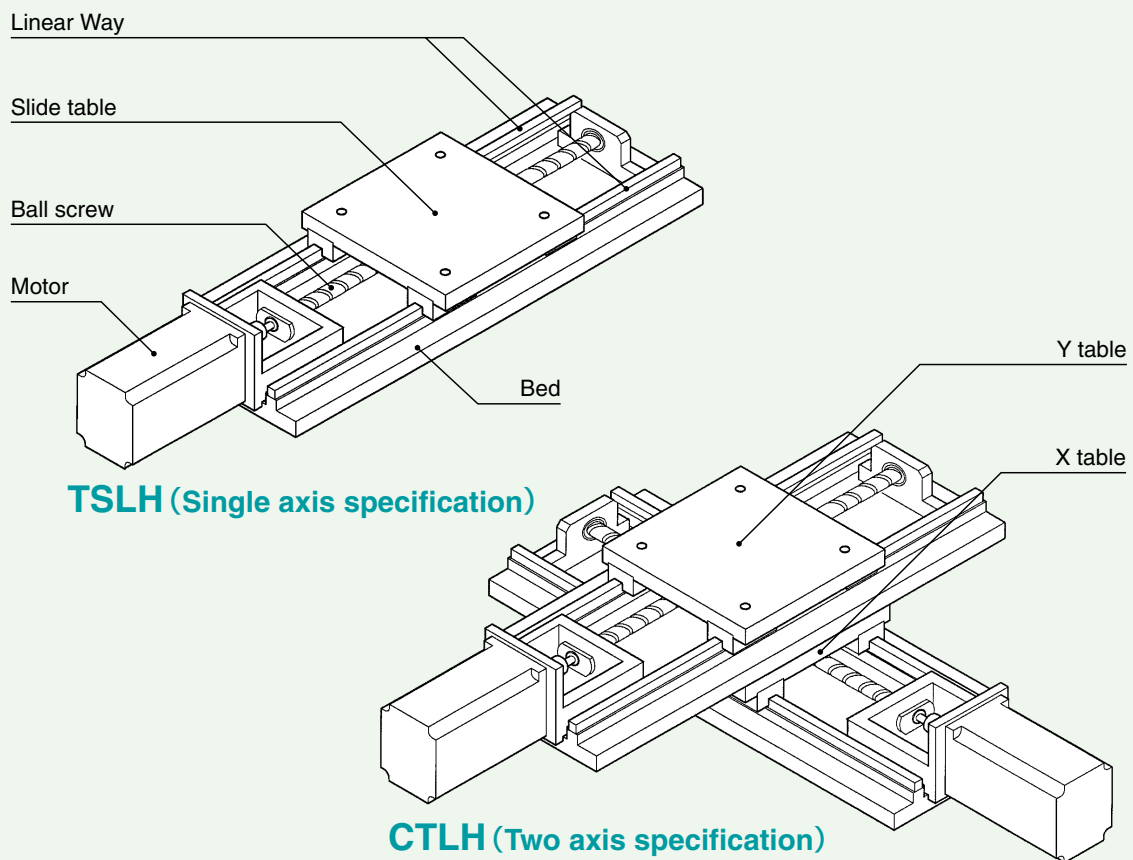

***Structure of Precision Positioning Table LH***

# Features of TSLH and CTLH

## 1 *High running accuracy and positioning accuracy*

The slide table and bed made of cast iron are finished by grinding and high accuracy component parts are carefully selected for assembly, so both high running accuracy and high positioning accuracy can be obtained.

## 2 *High rigidity and large loading weight*

The design of the table featuring optimal arrangement of two sets of Linear Ways mounted on a high rigidity bed achieves high strength under moment and complex load as well as high load capacity.

## 3 *Series includes the super large size with a table width of 420 mm*

Four sizes with table widths ranging from 120 mm up to super large size 420 mm are available. Two axis specification tables which combine these single tables are also available as standard specification. Stroke length can also be selected from many lengths provided.



**TSLH**  
(Single axis specification)



**TSLH**  
(Table with bellows)

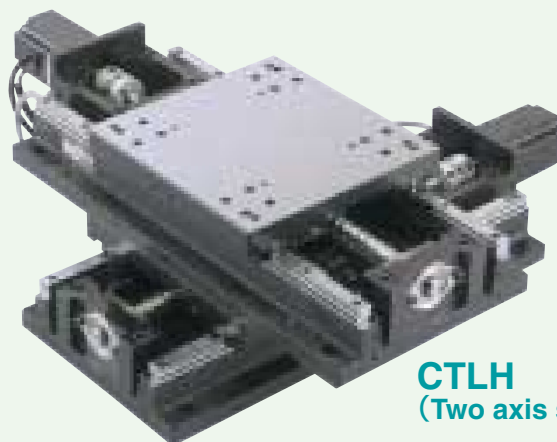

**CTLH**  
(Two axis specification)

# Identification Number

## Example of identification number (Single axis specification)

**TSLH 220 H - 200 A / A2 B 10 J G R**

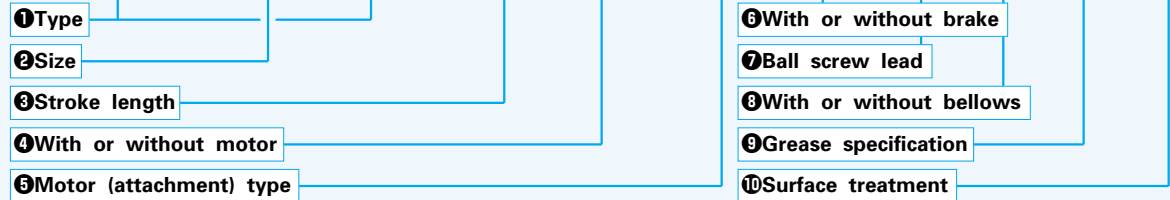

**1 Type** TSLH...H: Precision Positioning Table LH (Single axis specification)

**2 Size** 120: Table width 120mm, 220: Table width 220mm  
320: Table width 320mm, 420: Table width 420mm

**3 Stroke length** Stroke lengths in Table 1 are available.  
The stroke length of the table with bellows is a little shorter than that without bellows. Refer to the dimension table.

**Table 1 Stroke length**

Model number	Stroke length mm
TSLH120H	100, 150, 200, 250, 300
TSLH220H	150, 200, 250, 300, 400 (500, 600)
TSLH320H	300, 400, 500 (600, 800, 1000)
TSLH420H	500, 600, 800 (1000)

Remark: When the stroke length indicated in the parenthesis is required, consult **IKO**.

**4 With or without motor** No symbol: without motor, A: with motor  
In case the motor is provided by the customer, select "without motor" (No symbol).

**5 Motor (attachment) type** Select a motor code in Table 2.  
In case "without motor" (No symbol) is selected in item4, the motor attachment and coupling for the motor type selected in this item are attached.

**Table 2 Motor type and code**

Motor type	TSLH120H	TSLH220H	TSLH320H	TSLH420H
AC servo motor	A1, M1	A2, M2	A2, M2	AA4, MA4
Stepping motor	K6	K7	K7	—

Remark: Refer to motor specification on page 9.

**6 With or without brake** No symbol: without brake, B: with brake  
To specify "motor with brake", select "with brake" (select B).

**7 Ball screw lead** 5: Lead 5mm, 10: Lead 10mm (20: Lead 20mm)  
Remark: If 20 mm lead is required, consult **IKO**.

**8 With or without bellows** No symbol: without bellows, J: with bellows  
The stroke length of the table with bellows is a little shorter than that without bellows. Refer to the dimension table.

**9 Grease specification** No symbol: Shell Alvania EP2 grease, G: **IKO** Clean Environment Grease CG2

**10 Surface treatment** No symbol: Black chrome surface treatment, R: Black chrome surface treatment 1, L: Black chrome surface treatment 2  
Black chrome surface treatment: Treatment is made on all surfaces of main parts except Linear Ways, ball screw and ball bearings.  
Black chrome surface treatment 1: In addition to the above, treatment is made on the Linear Way surface.  
Black chrome surface treatment 2: In addition to the above treatment 1, treatment is made on the ball screw surface.  
Black chrome surface treatment is a surface treatment by which a black permeable film is formed on the surface to increase corrosion resistance. The films on the reference surfaces of parts are removed after the treatment.

## Example of identification number (Two axis specification)

**CTLH 220 H - 30 20 A / A2 B 5 J G R C**

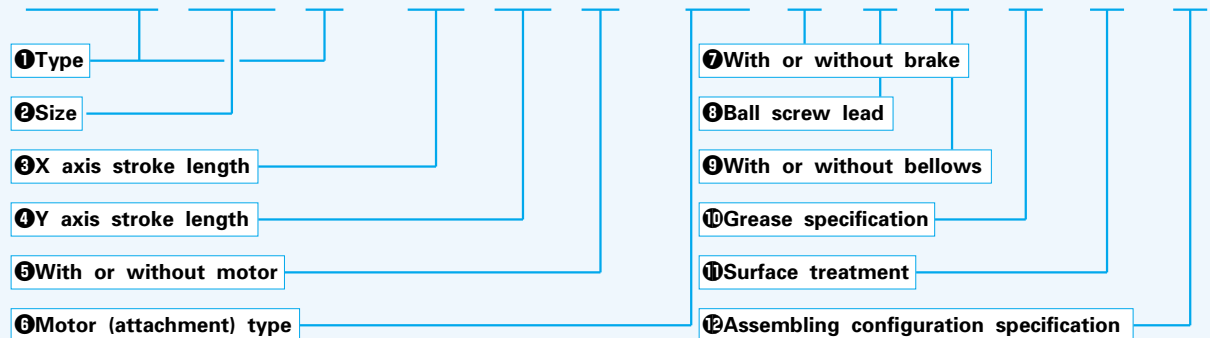

<b>1 Type</b>	CTLH···H: Precision Positioning Table LH (Two axis specification)
---------------	---

<b>2 Size</b>	120: Table width 120mm, 220: Table width 220mm 320: Table width 320mm
---------------	--

Single axis tables of different sizes can be assembled.

<b>3 4 Stroke length</b>	Refer to the dimension table.
--------------------------	-------------------------------

The stroke length of each axis is indicated in cm. The length that can be selected is different for X and Y axes. The stroke length of the table with bellows is a little shorter than that without bellows. Refer to the dimension table.

<b>5 With or without motor</b>	No symbol: without motor, A: with motor
--------------------------------	---

In case the motor is provided by the customer, select "without motor" (No symbol).

<b>6 Motor (attachment) type</b>	Select a motor code in Table 3.
----------------------------------	---------------------------------

In case "without motor" (No symbol) is selected in item 5, the motor attachment and coupling for the motor type selected in this item are attached.

**Table 3 Motor type and code**

Motor type	CTLH120H	CTLH220H	CTLH320H
AC servo motor	A1, M1	A2, M2	A2, M2
Stepping motor	K6	K7	K7

Remark: Refer to motor specification on page 9.

<b>7 With or without brake</b>	No symbol: without brake, B: with brake
--------------------------------	---

To specify "motor with brake", select "with brake" (select B). But the motor with brake is provided on Y axis only.

<b>8 Ball screw lead</b>	5: Lead 5mm, 10: Lead 10mm (20: Lead 20mm)
--------------------------	--

Remark: If 20 mm lead is required, please consult **IKO**.

<b>9 With or without bellows</b>	No symbol: without bellows, J: with bellows
----------------------------------	---

The stroke length of the table with bellows is a little shorter than that without bellows. Refer to the dimension table.

<b>10 Grease specification</b>	No symbol: Shell Alvania EP2 grease, G: <b>IKO</b> Clean Environment Grease CG2
--------------------------------	---

<b>11 Surface treatment</b>	No symbol: Black chrome surface treatment, R: Black chrome surface treatment 1, L: Black chrome surface treatment 2
-----------------------------	---

Black chrome surface treatment: Treatment is made on all surfaces of main parts except Linear Ways, ball screw and ball bearings.  
 Black chrome surface treatment 1: In addition to the above, treatment is made on the Linear Way surface.  
 Black chrome surface treatment 2: In addition to the above treatment 1, treatment is made on the ball screw surface.  
 Black chrome surface treatment is a surface treatment by which a black permeable film is formed on the surface to increase corrosion resistance. The films on the reference surfaces of parts are removed after the treatment.

<b>12 Assembling configuration specification</b>	No symbol: standard configuration, C: reverse configuration
--	---

Standard configuration: X and Y axes are assembled with the Y axis motor at right in sight of X axis motor in front.  
 Reverse configuration: X and Y axes are assembled with the Y axis motor at left in sight of X axis motor in front.

# Accuracy and Maximum Speed

The accuracy and the maximum speed of Precision Positioning Table LH are shown in Table 4 and Table 5. The values of the maximum speed shown in Table 5 are applicable when the standard motor is used. The actual maximum speed must be determined by examining the operation pattern for the motor used, load conditions, etc.

**Table 4 Accuracy**

unit: mm

Size	Stroke length		Positioning accuracy	Repeatability	Parallelism in operation A	Straightness	Squareness of XY travel	Back lash	
	X axis	Y axis							
Single axis specification	TSLH120H	100	0.010	±0.002	0.010	0.005	—	0.001	
		150							
		200	0.015		0.015	0.010			
		250							
		300							
	TSLH220H	150	0.010	±0.002	0.010	0.005	—	0.001	
		200							
		250	0.015		0.015				0.010
		300							
	400	0.020							
	TSLH320H	300	0.015	±0.002	0.015	0.005	—	0.001	
		400	0.020						
500									
TSLH420H	500	0.025	±0.002	0.025	0.015	—	0.001		
	600	0.030		0.030					
	800	0.035		0.035				0.020	
Two axis specification	CTLH120H	100	100	±0.002	0.015	0.005	0.005	0.001	
		200	100		0.020	0.020			0.010
		200	200			0.025			
		300	200		0.030	0.030			0.025
		300	300						
	CTLH220H	200	200	±0.002	0.025	0.010	0.010	0.001	
		300	200						
		300	300						0.030
		400	300						
		400	400						
	CTLH320H	300	300	±0.002	0.020	0.005	0.010	0.001	
		400	300						
400		400	0.025						
500		400							
500		500							0.030

**Table 5 Maximum speed**

Motor type	Size		Motor speed rpm	Maximum speed mm/s	
	Single axis specification	Two axis specification		Lead 5 mm	Lead 10mm
AC servo motor	TSLH120H TSLH220H	CTLH120H CTLH220H	3000	250	500
	TSLH320H TSLH420H	CTLH320H	2690	224	448
Stepping motor	TSLH120H TSLH220H TSLH320H	CTLH120H CTLH220H CTLH320H	1800	150	300



# Maximum Loading Mass

Table 6 shows the maximum loading mass of Precision Positioning Table LH. The maximum loading mass is a general value of the maximum mass that can be loaded on the table when the table is used in a horizontal position. The value of the maximum mass varies depending on the positions (height distance  $H$  and length distance  $L$ ) where the mass is loaded.

**Table 6 Maximum loading mass**

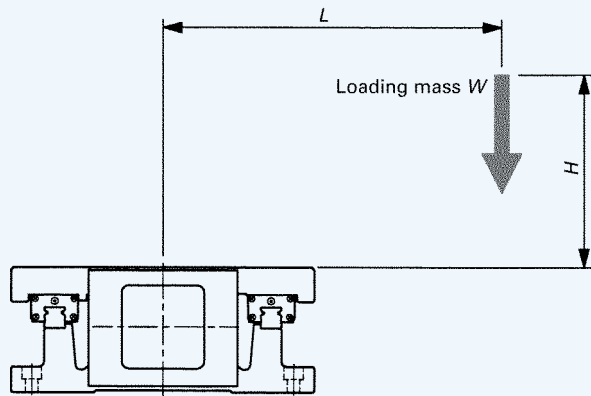

unit: kg

Size	Height distance $H$ mm	Length distance $L$ mm								
		0	100	200	300	400	500	600	800	1000
TSLH120H	0	110	56	33	23	18	15	12	9.4	7.6
	200	110	52	32	23	18	15	12	9.4	7.6
	400	81	45	30	22	17	14	12	9.4	7.6
	600	59	39	28	21	17	14	12	9.3	7.5
TSLH220H	0	240	140	88	64	50	42	35	27	22
	200	240	130	85	63	50	41	35	27	22
	400	200	120	81	61	49	41	35	27	22
	600	160	100	76	59	48	40	34	27	22
TSLH320H	0	410	370	250	190	150	130	110	85	70
	200	410	350	240	190	150	130	110	85	69
	400	410	320	230	180	150	120	110	84	69
	600	410	290	220	170	140	120	110	83	69
TSLH420H	0	410	410	340	270	220	180	160	120	100
	200	410	410	340	260	220	180	160	120	100
	400	410	410	330	260	210	180	160	120	100
	600	410	410	310	250	210	180	150	120	100

Remark 1: The maximum loading mass is obtained by calculating the mass under which the rating life of the ball screw or linear way becomes 18000 hours when the table is continuously operated in an operation pattern consisting of 0.2s duration each at the maximum speed (for each size), at acceleration, and at deceleration.

2: For the two axis specification table, examine the loading mass for each axis.

1N=0.102kgf=0.2248lbs.  
1mm=0.03937inch

# Motor Specifications

An AC servo motor and a stepping motor can be selected for Precision Positioning Table LH. Also, for both motor types, "with brake" can be specified. So selection can be made from wide variations meeting the requirements for each application.

Table 7 shows the types of standard motors. Table 8 shows the types of connectors used for each motor.

**Table 7 Type of standard motor**

Size	Motor type	With or without brake	Motor code	Model number	Remark
TSLH120H CTLH120H(*)	AC servo motor	Without brake	A1	SGM-01B512	Yaskawa Electric Corporation
			M1	MSM011A1A	Matsushita Electric Industrial Co., Ltd.
		With brake	A1B	SGM-01B512B	Yaskawa Electric Corporation
			M1B	MSM011A1B	Matsushita Electric Industrial Co., Ltd.
	Stepping motor	Without brake	K6	PK569-A	Oriental Motor Co., Ltd.
		With brake	K6B	PK569-A-A25	
TSLH220H TSLH320H CTLH220H(*) CTLH320H(*)	AC servo motor	Without brake	A2	SGM-02B512	Yaskawa Electric Corporation
			M2	MSM021A1A	Matsushita Electric Industrial Co., Ltd.
		With brake	A2B	SGM-02B512B	Yaskawa Electric Corporation
			M2B	MSM021A1B	Matsushita Electric Industrial Co., Ltd.
	Stepping motor	Without brake	K7	PK596-A	Oriental Motor Co., Ltd.
		With brake	K7B	PK596-A-A25	
TSLH420H	AC servo motor	Without brake	AA4	SGM-04A512	Yaskawa Electric Corporation
			MA4	MSM042A1A	Matsushita Electric Industrial Co., Ltd.
		With brake	AA4B	SGM-04A512B	Yaskawa Electric Corporation
			MA4B	MSM042A1B	Matsushita Electric Industrial Co., Ltd.

Note(\*): The motor with brake is attached to Y axis only for the two axis table with brake.

**Table 8 Type of applicable connector**

Motor type	Connector type	Motor code		Type of motor-side connector		Type of opposite-side connector		
				Plug housing	Contactar	Cap housing	Contactar	
AC servo motor	Motor connector	Without brake	A...	172167-1	170360-1	172159-1	170362-1	
			M...					172168-1
		With brake	A...B					172167-1
			M...B					172165-1
	Encoder connector	A...	172169-1	170359-1	172161-1	170361-1		
		M...	172171-1		172163-1			
Stepping motor	Motor connector	K...	172170-1	170364-1	172162-1	170366-1		

Remark: Manufactured by AMP

# Sensor Specifications

Table 9 shows a timing chart of the sensors used in Precision Positioning Table LH and Table 10 shows connector specifications.

**Table 9 Sensor timing chart**

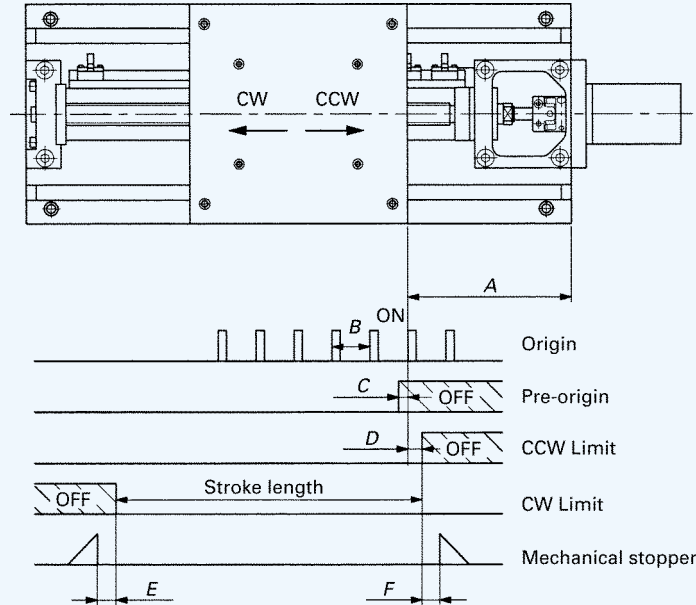

unit: mm

Size	Ball screw lead	A	B	C	D	E	F
TSLH120H	5	50	5	3	30	5.5	4.5
	10		10	7			
TSLH220H	5	45	5	3	30	14	10
	10		10	7		12	10
TSLH320H	5	45	5	3	30	19	15
	10		10	7		17	15
TSLH420H	5	45	5	3	30	18	15
	10		10	7			

Remark 1: For a two axis table, the sensor specification for the single axis table is applicable for each axis.

2: For a table with bellows, the values shown in the above table are not applicable.

3: For a table with AC servo motor, the origin sensor is not attached. Use C phase or Z phase signal of motor encoder for origin signal.

**Table 10 Specification of connector**

Pin No.	Signal	Sensor specification (Optical sensor)	Sensor(table) side connector	Contact side connector <sup>(1)</sup>
1	Origin	Open collector output Less than DC 30V 100mA max	Cap-housing 172160-1	Plug-housing 172168-1
2	Pre-origin			
3	CW Limit		Contactor 170365-1	Contactor 170363-1
4	CCW Limit			
5	Power supply voltage (DC5~24V)			
6	GND			

Note<sup>(1)</sup>: Manufactured by AMP

Remark: For a table with AC servo motor, wiring for origin sensor is not provided.

1N=0.102kgf=0.2248lbs.  
1mm=0.03937inch

# Electric Devices

## System configuration

Electric devices for Precision Positioning Table LH are specially designed to bring out full performance of the table. A well balanced system can be obtained by using these devices with the table. Tables 11 to 15 show system configurations of the table with the electric devices when a standard motor is used.

### System configuration of a table with AC servo motor(configuration with a control unit)

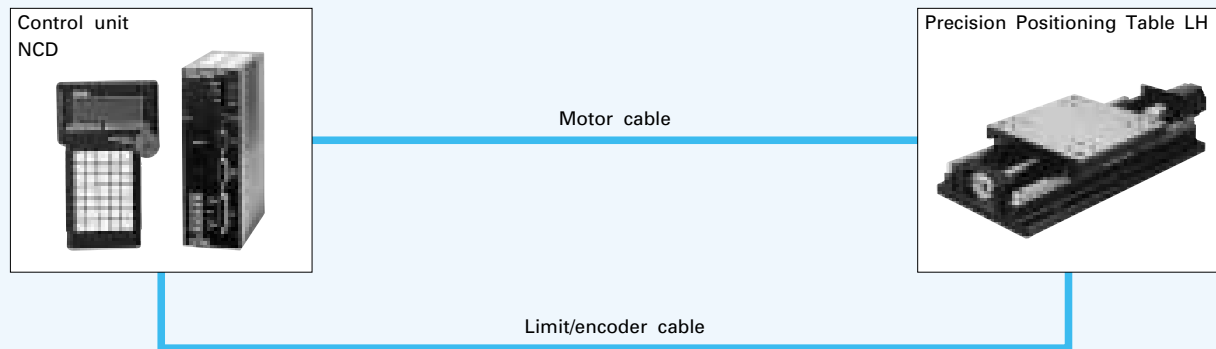

### System configuration of a table with AC servo motor(configuration with a driver and a programmable controller)

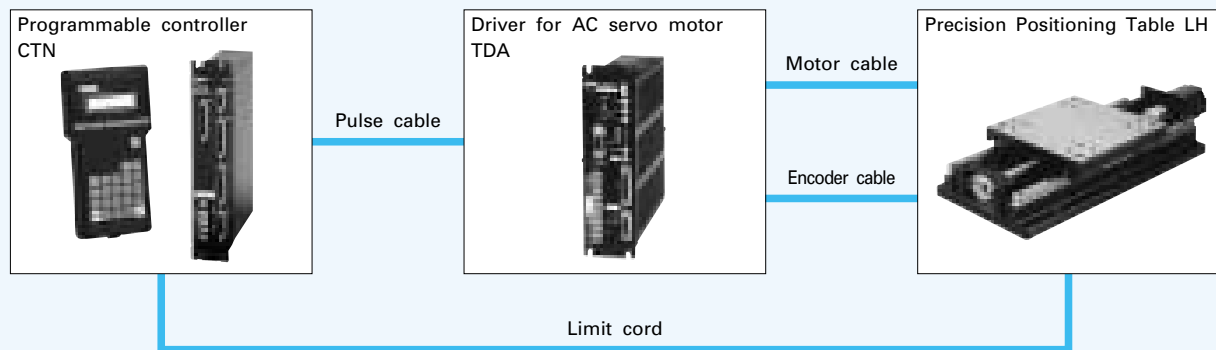

### System configuration of a table with stepping motor

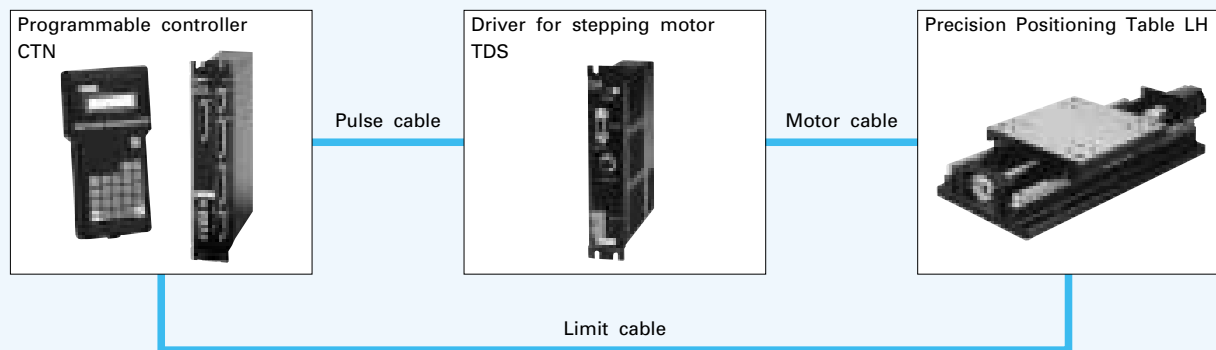

Fig.1 System configuration

**Table 11 System configuration of TSLH(single axis specification) with AC servo motor(configuration with a control unit)**

Size	With or without brake	Motor code	Control unit			
			Main body	Teaching box	Motor cable	Limit-encoder cable
TSLH120H TSLH220H TSLH320H	Without brake	A1、A2	NCD160G-A2006	TAE1050-TB	TAE2065-AM03 (TAE2072-AM03)	TAE2066-AEL03 (TAE2073-AEL03)
		M1、M2				TAE2067-AEL03 (TAE2074-AEL03)
	With brake	A1B、A2B	NCD160G-A2006 TAE1049-BK(!)	TAE1050-TB	TAE2070-AMB03 (TAE2077-AMB03)	TAE2066-AEL03 (TAE2073-AEL03)
		M1B、M2B				TAE2071-AMB03 (TAE2078-AMB03)

Note(!): Brake regenerative unit type. Connect it to the main body of driver.

Remark 1: The cables in the parentheses have high bending resistance.

2: The standard length of the cable is 3m.

3: For TSLH420H system configuration, please consult **IKO**.

**Table 12 System configuration of TSLH (single axis specification) with AC servo motor(configuration with a driver and a programmable controller)**

Size	With or without brake	Motor code	Type of applicable electric devices						
			Driver			Programmable controller			
			Main body	Motor cable	Encoder cable	Main body	Teaching box	Pulse cable	Limit cable
TSLH120H	Without brake	A1	TDA 1-1004	TAE2052-AM03 (TAE2036-AM03)	TAE2054-AE03 (TAE2038-AE03)	CTN120G	TAE1005-TB	TAE1022-LD03	
						CTN130G	TAE1016-TB	TAE1012-PC	TAE1042-LC03
						CTN140G	TAE1025-TB	TAE1030-PC	TAE1027-LCA03
						CTN150S	TAE1048-TB	TAE1022-LD03	
	With brake	A1B	TDA 1-1004BK	TAE2053-AMB03 (TAE2037-AMB03)		CTN120G	TAE1005-TB	TAE1022-LD03	
						CTN130G	TAE1016-TB	TAE1012-PC	TAE1042-LC03
						CTN140G	TAE1025-TB	TAE1030-PC	TAE1027-LCA03
						CTN150S	TAE1048-TB	TAE1022-LD03	
TSLH220H TSLH320H	Without brake	A2	TDA 1-2004	TAE2052-AM03 (TAE2036-AM03)	TAE2054-AE03 (TAE2038-AE03)	CTN120G	TAE1005-TB	TAE1022-LD03	
						CTN130G	TAE1016-TB	TAE1012-PC	TAE1042-LC03
						CTN140G	TAE1025-TB	TAE1030-PC	TAE1027-LCA03
						CTN150S	TAE1048-TB	TAE1022-LD03	
	With brake	A2B	TDA 1-2004BK	TAE2053-AMB03 (TAE2037-AMB03)		CTN120G	TAE1005-TB	TAE1022-LD03	
						CTN130G	TAE1016-TB	TAE1012-PC	TAE1042-LC03
						CTN140G	TAE1025-TB	TAE1030-PC	TAE1027-LCA03
						CTN150S	TAE1048-TB	TAE1022-LD03	

Remark 1: The cables in the parentheses have high bending resistance.

2: The standard lengths of the motor cable, encoder cable, and limit cable are 3m. The length of the pulse cable is 1.5m.

3: For TSLH420H system configuration, please consult **IKO**.

**Table 13 System configuration of TSLH (single axis specification) with stepping motor**

Size	With or without brake	Motor code	Type of applicable electric devices					
			Driver		Programmable controller			
			Main body	Motor cable	Main body	Teaching box	Pulse cable	Limit cable
<b>TSLH120H</b>	Without brake	K6	TDS1-5145	TAE2045-SML03 (TAE2059-SNL03)	CTN120G	TAE1005-TB	TAE1022-LD03	
					CTN130G	TAE1016-TB	TAE1012-PC	TAE1042-LC03
					CTN140G	TAE1025-TB	TAE1030-PC	TAE1027-LCA03
					CTN150S	TAE1048-TB	TAE1022-LD03	
	With brake	K6B	TDS1-5145BK	TAE2061-SMBL03 (TAE2062-SNBL03)	CTN120G	TAE1005-TB	TAE1022-LD03	
					CTN130G	TAE1016-TB	TAE1012-PC	TAE1042-LC03
					CTN140G	TAE1025-TB	TAE1030-PC	TAE1027-LCA03
					CTN150S	TAE1048-TB	TAE1022-LD03	
<b>TSLH220H</b> <b>TSLH320H</b>	Without brake	K7	TDS1-5145	TAE2045-SML03 (TAE2059-SNL03)	CTN120G	TAE1005-TB	TAE1022-LD03	
					CTN130G	TAE1016-TB	TAE1012-PC	TAE1042-LC03
					CTN140G	TAE1025-TB	TAE1030-PC	TAE1027-LCA03
					CTN150S	TAE1048-TB	TAE1022-LD03	
	With brake	K7B	TDS1-5145BK	TAE2061-SMBL03 (TAE2062-SNBL03)	CTN120G	TAE1005-TB	TAE1022-LD03	
					CTN130G	TAE1016-TB	TAE1012-PC	TAE1042-LC03
					CTN140G	TAE1025-TB	TAE1030-PC	TAE1027-LCA03
					CTN150S	TAE1048-TB	TAE1022-LD03	

Remark 1: The cables in the parentheses have high bending resistance.

2: The standard lengths of the motor cable and limit cable are 3m. The length of the pulse cable is 1.5m.

**Table 14 System configuration of CTLH (two axis specification) with AC servo motor(configuration with a driver and a programmable controller)**

Size	With or without brake	Motor code	Type of applicable electric devices						
			Driver			Programmable controller			
			Main body	Motor cable	Encoder cable	Main body	Teaching box	Pulse cable	Limit cable
CTLH120H	Without brake	A1	TDA 1-1004 2 sets	TAE2052-AM03 (TAE2036-AM03) 2 pieces	TAE2054-AE03 (TAE2038-AE03) 2 pieces	CTN220G	TAE1005-TB	TAE1038-LYY03	
						CTN230G	TAE1016-TB	TAE1013-PCY	TAE1043-LCY03
	CTN240G	TAE1025-TB	TAE1031-PCY	TAE1029-LCAY03					
	CTN220G	TAE1005-TB	TAE1038-LYY03						
With brake	A1B	TDA 1-1004 + TDA 1-1004BK	TAE2052-AM03 (TAE2036-AM03) + TAE2053-AMB03 (TAE2037-AMB03)	CTN230G	TAE1016-TB	TAE1013-PCY	TAE1043-LCY03		
				CTN240G	TAE1025-TB	TAE1031-PCY	TAE1029-LCAY03		
CTLH220H CTLH320H	Without brake	A2	TDA 1-2004 2 sets	TAE2052-AM03 (TAE2036-AM03) 2 pieces	TAE2054-AE03 (TAE2038-AE03) 2 pieces	CTN220G	TAE1005-TB	TAE1038-LYY03	
						CTN230G	TAE1016-TB	TAE1013-PCY	TAE1043-LCY03
	CTN240G	TAE1025-TB	TAE1031-PCY	TAE1029-LCAY03					
	CTN220G	TAE1005-TB	TAE1038-LYY03						
With brake	A2B	TDA 1-2004 + TDA 1-2004BK	TAE2052-AM03 (TAE2036-AM03) + TAE2053-AMB03 (TAE2037-AMB03)	CTN230G	TAE1016-TB	TAE1013-PCY	TAE1043-LCY03		
				CTN240G	TAE1025-TB	TAE1031-PCY	TAE1029-LCAY03		

Remark 1: The cables in the parentheses have high bending resistance.

2: The standard lengths of the motor cable, encoder cable, and limit cable are 3m. The length of the pulse cable is 1.5m.

3: For the table with brake, the brake is attached to Y axis motor only.

**Table 15 System configuration of CTLH (two axis specification) with stepping motor**

Size	With or without brake	Motor code	Type of applicable electric devices					
			Driver		Programmable controller			
			Main body	Motor cable	Main body	Teaching box	Pulse cable	Limit cable
CTLH120H	Without brake	K6	TDS2-5145	TAE2045-SML03 (TAE2059-SNL03) 2 pieces	CTN220G	TAE1005-TB	TAE1034-LY03	
					CTN230G	TAE1016-TB	TAE1012-PC	TAE1043-LCY03
					CTN240G	TAE1025-TB	TAE1030-PC	TAE1029-LCAY03
	With brake	K6B	TDS2-5145BK	TAE2045-SML03 (TAE2059-SNL03) + TAE2061-SMBL03 (TAE2062-SNBL03)	CTN220G	TAE1005-TB	TAE1034-LY03	
CTN230G					TAE1016-TB	TAE1012-PC	TAE1043-LCY03	
CTLH220H CTLH320H	Without brake	K7	TDS2-5145	TAE2045-SML03 (TAE2059-SNL03) 2 pieces	CTN220G	TAE1005-TB	TAE1034-LY03	
					CTN230G	TAE1016-TB	TAE1012-PC	TAE1043-LCY03
					CTN240G	TAE1025-TB	TAE1030-PC	TAE1029-LCAY03
	With brake	K7B	TDS2-5145BK	TAE2045-SML03 (TAE2059-SNL03) + TAE2061-SMBL03 (TAE2062-SNBL03)	CTN220G	TAE1005-TB	TAE1034-LY03	
CTN230G					TAE1016-TB	TAE1012-PC	TAE1043-LCY03	
CTN240G	TAE1025-TB	TAE1030-PC	TAE1029-LCAY03					

Remark 1: The cables in the parentheses have high bending resistance.

2: The standard lengths of the motor cable and limit cable are 3m. The length of the pulse cable is 1.5m.

3: For the table with brake, the brake is attached to Y axis motor only.

## Driver

**Table 16 Main specification of driver for AC servo motor**

Item	Type	TDA1-1004	TDA1-2004
Number of control axes		1	
Rated output of applicable motor		30W、50W、100W	100W、200W
Feedback		Incremental encoder	
Command pulse input system		CW/CCW pulse or pulse/direction command	
Command pulse input form		Line driver or open collector (+5V level)	
Supply voltage		AC100V±10% 50/60Hz	
Current consumption		10A or less	12A or less
Ambient temperature (during operation)		0~50℃	
Ambient humidity (during operation)		35~85%RH (non-condensing)	
Mass (reference value)		2.0kg	2.2kg

**Table 17 Main specification of driver for stepping motor**

Item	Type	TDS1-5145	TDS2-5145
Number of control axes		1	2
Applicable motor		5-phase stepping motor of 0.75 to 1.4A/phase	
Drive method		Bipolar constant-current drive	
Excitation method		4 to 5-phase excitation or 4-phase excitation	
Command pulse input system		CW/CCW pulse	
Command pulse input form		Line driver or open collector (+5V level)	
Supply voltage		AC100V±10% 50/60Hz	
Current consumption		5A以下	10A以下
Ambient temperature (during operation)		0~50℃	
Ambient humidity (during operation)		35~85%RH (non-condensing)	
Mass (reference value)		1.3kg	2.0kg

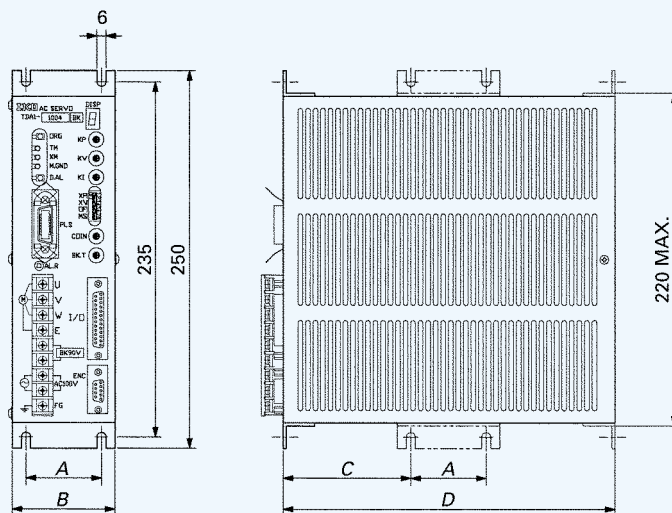

unit: mm

Type	A	B	C	D
TDA	50	68	85	220
TDS1-5145	25	48	72.5	169.5
TDS2-5145	50	74	60	169.5

**Fig.2 Dimensions of driver**

Remark: The drawing shows TDA1-1004.



## Control unit

**Table 18 Main specifications of control unit**

Item	Type	NCD160G-A2006
Number of control axes		1
Applicable motor		AC servo motor 100W、200W
Feedback		Incremental encoder
Maximum command value		$\pm 2147483647\mu\text{m}$
Motor speed		Rated motor speed 3,000rpm, maximum motor speed 4,500rpm
Input method		MDI, teaching and PC input via RS-232C
Command input system		Absolute command or incremental command
Program capacity		12k bytes (1,200 steps or more)
Number of positioning points		256 points
Functions		Jump, call, repetition, speed setting, acceleration/deceleration setting, timer control, I/O control, branching by input conditions, various editing functions (such as creation, deletion, erasing, and insertion)
Number of I/O points		LS input: 3 points, I/O input: 23 points, I/O output: 15 points
Power supply for input and output		DC24V 1A
Protective functions		Over-current, over-voltage, over-load, over-speed, voltage drop, encoder error, deviation error, over-heat, CPU error, etc.
Other major functions		RS-232C (reading, writing, direct execution, etc.), software limit, torque limitation, torque monitoring, speed change during movement, LS logic change, various check functions, brake regenerative unit (optional) <sup>(1)</sup> , etc.
Supply voltage		AC85~132V 50/60Hz
Current consumption		12A or less
Ambient temperature (during operation)		0~50°C
Ambient humidity (during operation)		35~85%RH (non-condensing)
Weight (reference value)		Main body 1.6kg, teaching box 0.5kg

Note<sup>(1)</sup>: This regenerative unit contains a brake power supply for motor with brake. (TAE1049-BK)

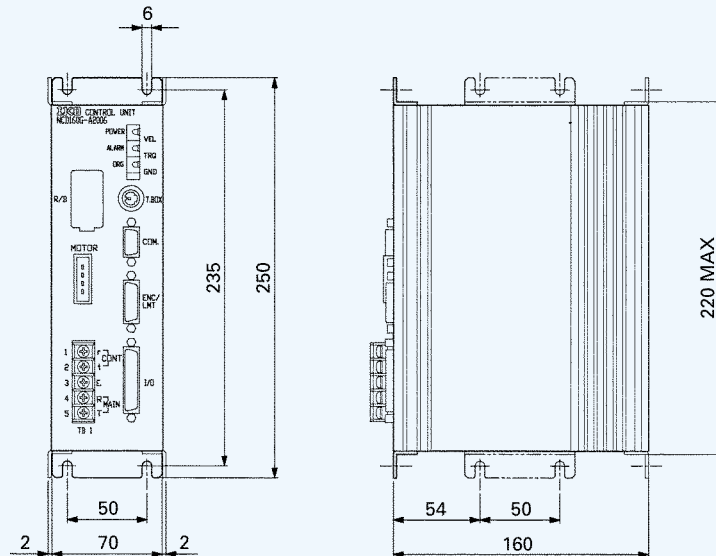
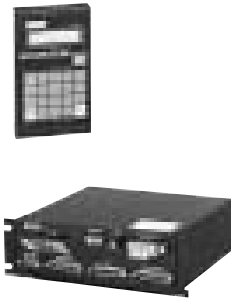
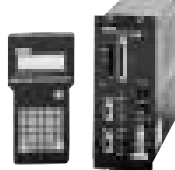



**Fig.3 Dimensions of control unit**

## ■Programmable controller

Programmable controller is available in four types: three program input types and one point memory type. Table 19 shows types and characteristics of programmable controllers. A model best suited for the requirement of application can be selected.

**Table 19 Main specifications of programmable controller**

Model	Program input type			Point memory type	
	CTN120G CTN220G	CTN130G CTN230G CTN430G	CTN140G CTN240G	CTN150S	
Type	Standard type	High-function type	Compact type		
Appearance					
Number of control axes	1 or 2 axes	1, 2, or 4 axes	1 or 2 axes	1 axis	
Supply voltage	AC90~110V	AC85~132V	DC24V±10%	DC24V±10%	
Maximum output frequency	200kpps	1.5Mpps	200kpps	2.5Mpps	
Pulse output system	CW/CCW pulse or direction command/forward and reverse pulses				
	Current discharge type	Line driver	Line driver	Line driver	
Maximum command value	±999999 pulses	±99999999 pulses	±999999 pulses	±2147483648 pulses	
Acceleration/deceleration method	Straight line	Straight line, S shaped line	Straight line	Straight line, S shaped line, cycloid	
Command input system	Absolute command or incremental command				
Program capacity	1000 steps	2000 steps	1000 steps	64-point memory (not programmable)	
General input and output (I/O)	Input	8 points (CTN120G) 20 points (CTN220G)	20 points	8 points (CTN140G) 20 points (CTN240G)	None
	Output	7 points (CTN120G) 12 points (CTN220G)	12 points	7 points (CTN140G) 12 points (CTN240G)	None
Linear and arc interpolation		○ (CTN220G)	○ (CTN230G、CTN430G)	×	×
	Point pass	○	×	×	×
General input and output add-ons	×	○	×	×	
Memory card	○	○	×	×	
RS-232C operation	○	○	○	○	
Position correction of linear scale	×	○	×	×	
Remarks	The program input type is so designed that programs entered by a teaching box or PC are executed in order of steps. Programming is possible with an optional teaching box or PC, or by simple teaching.			The point memory type does not come with a program function. Stored points are switched over and executed with an external device such as a sequencer or PC.	
	Standard type with 100V AC power supply input. The interpolation function of CTN220G comes with a point pass function as standard specification.	High-function type with a 100V AC power supply input. High-speed output at 1.5Mpps maximum. A series of multi-axis controllers up to four-axis control.	A type to be incorporated into compact electric devices with a 24V DC power supply input.		

Remark : ○ indicates that the unit has the function. × indicates that the unit does not have the function.

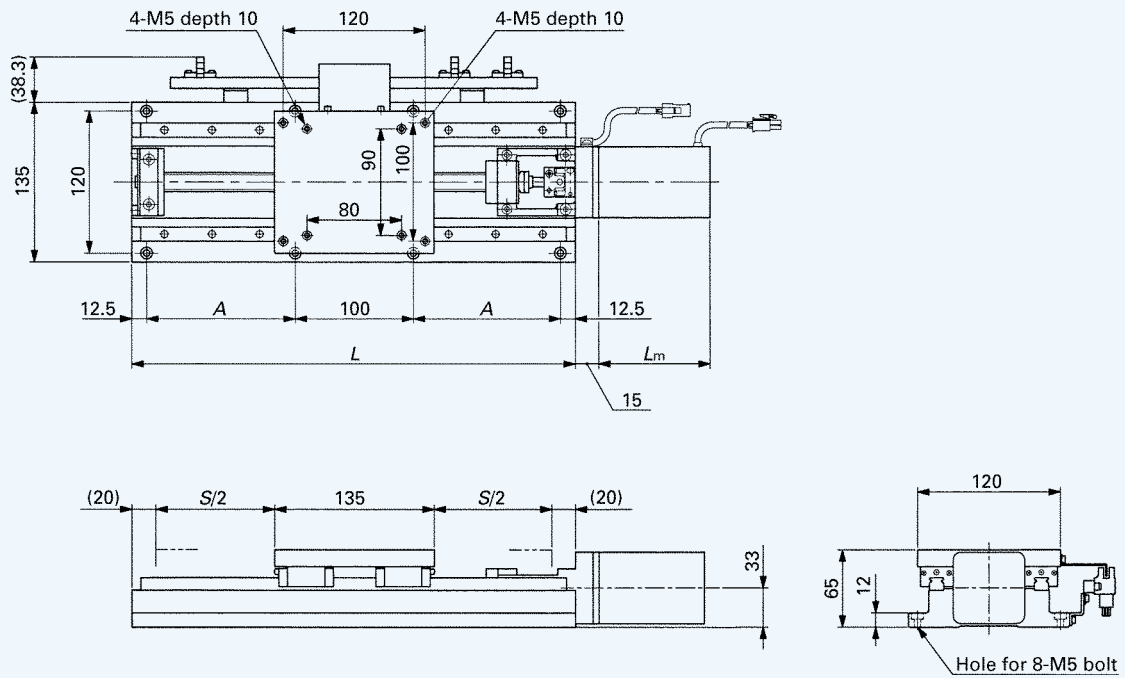

unit: mm

Model number	Stroke length $S$	Total length $L$	Mounting hole of bed $A$	Mass <sup>(1)</sup> (Reference) kg
<b>TSLH120H-100</b>	100	275	75	9.8
<b>TSLH120H-150</b>	150	325	100	10.8
<b>TSLH120H-200</b>	200	375	125	11.9
<b>TSLH120H-250</b>	250	425	150	12.9
<b>TSLH120H-300</b>	300	475	175	14.0

Note<sup>(1)</sup> : The motor mass is not included.

Dimensions of motor  $L_m$

unit: mm

Motor type	AC servo motor		Stepping motor
Motor code	A1	M1	K6
Without brake	94.5	103	87
With brake	135	135	129

1N=0.102kgf=0.2248lbs.  
1mm=0.03937inch

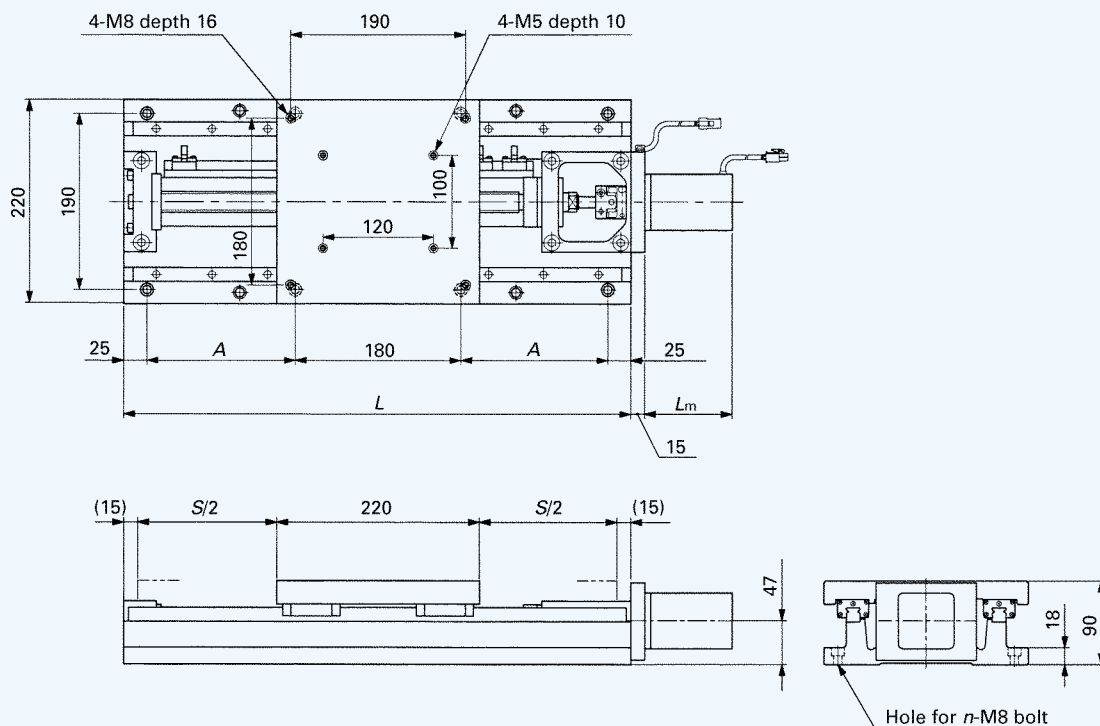

unit: mm

Model number	Stroke length S	Total length L	Mounting hole of bed		Mass <sup>(1)</sup> (Reference) kg
			A (quantity × pitch)	n	
TSLH220H-150	150	400	85	8	31.1
TSLH220H-200	200	450	110	8	33.3
TSLH220H-250	250	500	135	8	35.5
TSLH220H-300	300	550	160	8	37.6
TSLH220H-400	400	650	210 (2×105)	12	42.0
(TSLH220H-500)	500	750	260 (2×130)	12	46.4
(TSLH220H-600)	600	850	310 (2×155)	12	50.8

Note<sup>(1)</sup> : The motor mass is not included.

Remark: If the model number in the parenthesis is required, please consult **IKO**.

Dimensions of motor L<sub>m</sub>

unit: mm

Motor type	AC servo motor		Stepping motor
	A2	M2	
Motor code	A2	M2	K7
Without brake	96.5	95	66
With brake	136	128	119

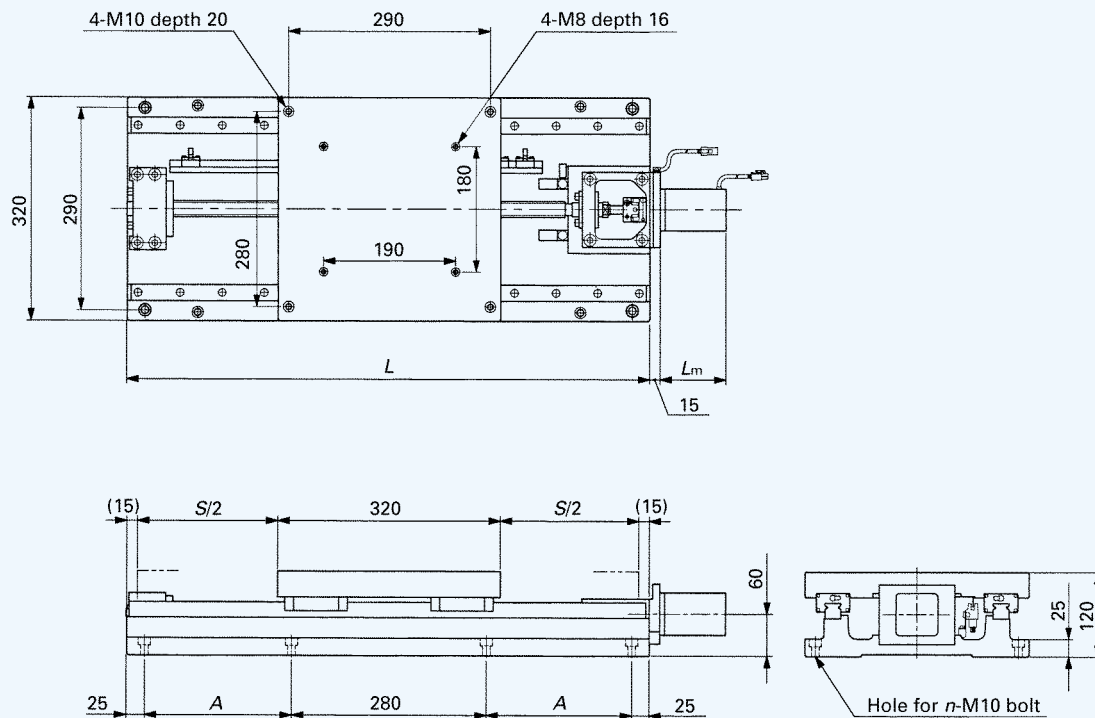

unit: mm

Model number	Stroke length S	Total length L	Mounting hole of bed		Mass <sup>(1)</sup> (Reference) kg
			A (quantity × pitch)	n	
TSLH320H- 300	300	650	160	8	99.5
TSLH320H- 400	400	750	210	8	109
TSLH320H- 500	500	850	260	8	118
(TSLH320H- 600)	600	950	310	8	127
(TSLH320H- 800)	800	1150	410 (2×205)	12	146
(TSLH320H-1000)	1000	1350	510 (2×255)	12	164

Note<sup>(1)</sup> : The motor mass is not included.

Remark: If the model number in the parenthesis is required, please consult **IKO**.

Dimensions of motor  $L_m$

unit: mm

Motor type	AC servo motor		Stepping motor
	A2	M2	
Motor code	A2	M2	K7
Without brake	96.5	95	66
With brake	136	128	119

1N=0.102kgf=0.2248lbs.  
1mm=0.03937inch

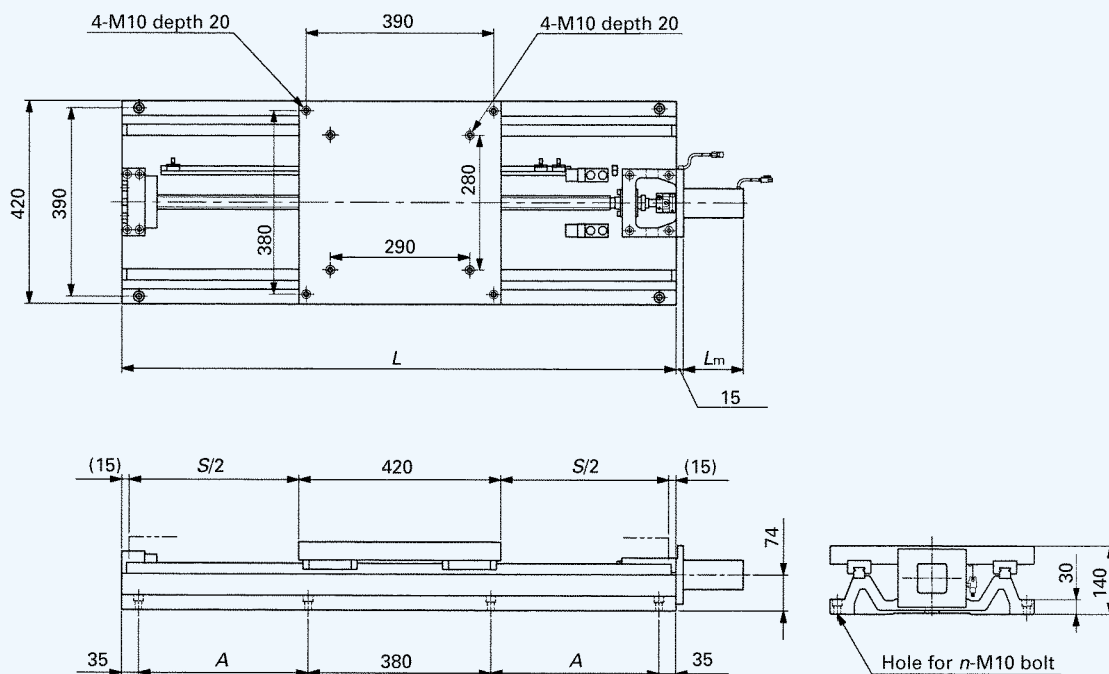

unit: mm

Model number	Stroke length S	Total length L	Mounting hole of bed		Mass <sup>(1)</sup> (Reference) kg
			A (quantity × pitch)	n	
TSLH420H- 500	500	950	250	8	176
TSLH420H- 600	600	1050	300	8	188
TSLH420H- 800	800	1250	400 (2×200)	12	212
(TSLH420H-1000)	1000	1450	500 (2×250)	12	237

Note<sup>(1)</sup> : The motor mass is not included.

Remark: If the model number in the parenthesis is required, please consult **IKO**.

Dimensions of motor  $L_m$

unit: mm

Motor type	AC servo motor	
Motor code	AA4	MA4
Without brake	124.5	124
With brake	164	157

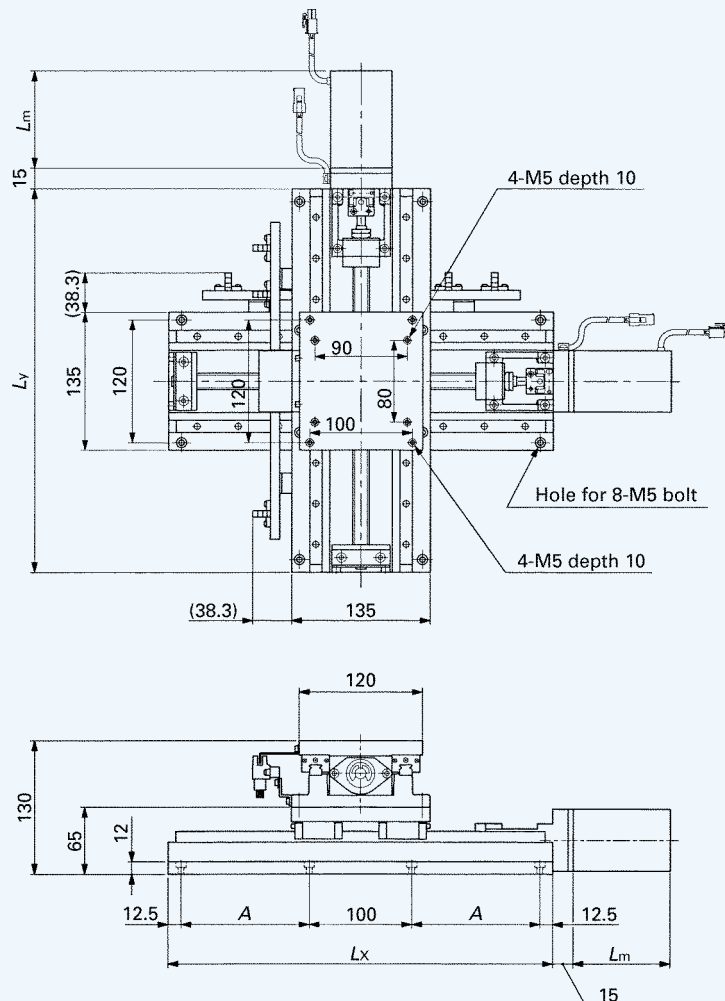

unit: mm

Model number	Stroke length S		Total length		Mounting hole of bed A	Mass <sup>(1)</sup> (Reference) kg
	X axis	Y axis	Lx	Ly		
CTLH120H-1010	100	100	275	275	75	19.6
CTLH120H-2010	200	100	375	275	125	21.7
CTLH120H-2020	200	200	375	375	125	23.8
CTLH120H-3020	300	200	475	375	175	25.8
CTLH120H-3030	300	300	475	475	175	27.9

Note<sup>(1)</sup> : The motor mass is not included.

Remark: If other stroke length or a combination of single axis tables of different sizes is required, please consult **IKO**.

Dimensions of motor L<sub>m</sub>

unit: mm

Motor type	AC servo motor		Stepping motor
Motor code	A1	M1	K6
Without brake	94.5	103	87
With brake	135	135	129

1N=0.102kgf=0.2248lbs.  
1mm=0.03937inch

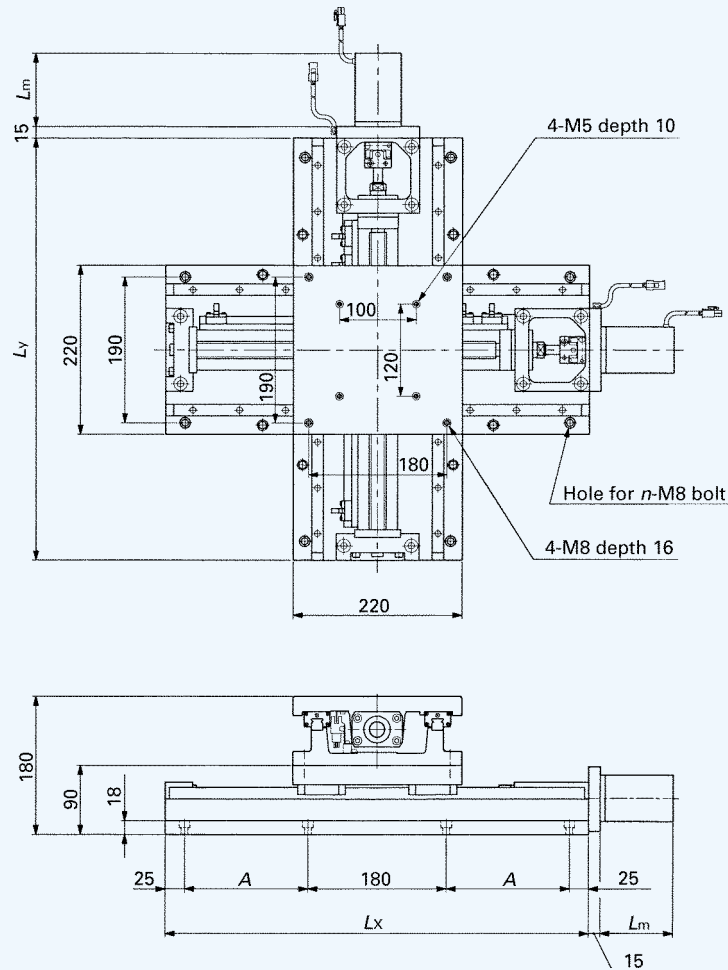

unit: mm

Model number	Stroke length <i>S</i>		Total length		Mounting hole of bed		Mass <sup>(1)</sup> (Reference) kg
	X axis	Y axis	<i>L<sub>x</sub></i>	<i>L<sub>y</sub></i>	<i>A</i> (quantity X pitch)	<i>n</i>	
CTLH220H-2020	200	200	450	450	110	8	66.5
CTLH220H-3020	300	200	550	450	160	8	70.9
CTLH220H-3030	300	300	550	550	160	8	75.3
CTLH220H-4030	400	300	650	550	210 (2×105)	12	79.7
CTLH220H-4040	400	400	650	650	210 (2×105)	12	84.0

Note<sup>(1)</sup> : The motor mass is not included.

Remark: If other stroke length or a combination of single axis tables of different sizes is required, please consult **IKO**.

Dimensions of motor *L<sub>m</sub>*

unit: mm

Motor type	AC servo motor		Stepping motor
Motor code	A2	M2	K7
Without brake	96.5	95	66
With brake	136	128	119



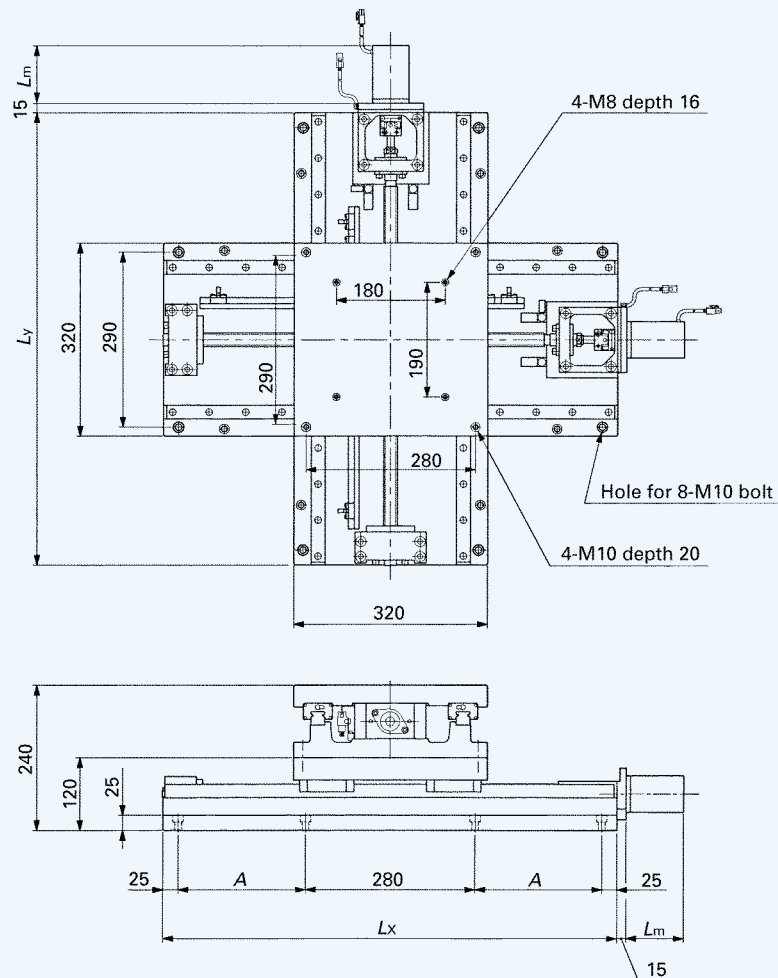

unit: mm

Model number	Stroke length $S$		Total length		Mounting hole of bed $A$	Mass <sup>(1)</sup> (Reference) kg
	X axis	Y axis	$L_x$	$L_y$		
CTLH320H-3030	300	300	650	650	160	199
CTLH320H-4030	400	300	750	650	210	208
CTLH320H-4040	400	400	750	750	210	217
CTLH320H-5040	500	400	850	750	260	227
CTLH320H-5050	500	500	850	850	260	236

Note<sup>(1)</sup> : The motor mass is not included.

Remark: If other stroke length or a combination of single axis tables of different sizes is required, please consult **IKO**.

Dimensions of motor  $L_m$

unit: mm

Motor type	AC servo motor		Stepping motor
Motor code	A2	M2	K7
Without brake	96.5	95	66
With brake	136	128	119

1N=0.102kgf=0.2248lbs.  
1mm=0.03937inch

# IKO Precision Positioning Table LH Table with bellows

## TSLH120H...J

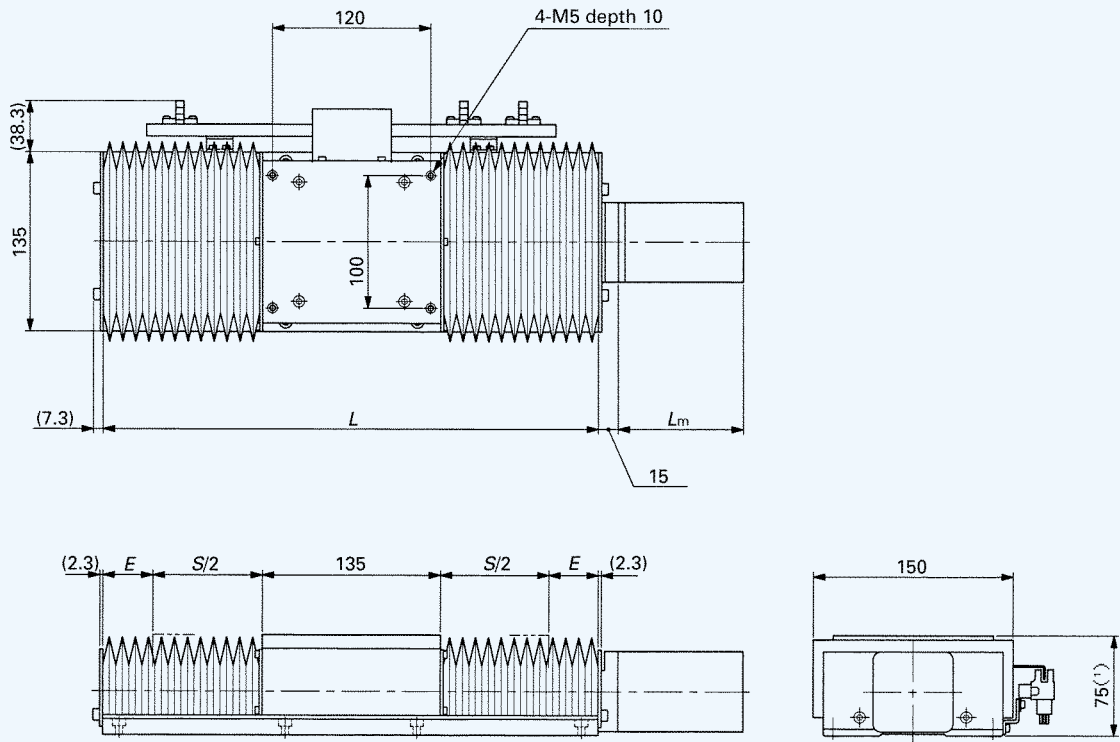

unit: mm

Model number	Stroke length S	Total length L	E
TSLH120H-100...J	85	275	27.5
TSLH120H-150...J	125	325	32.5
TSLH120H-200...J	165	375	37.5
TSLH120H-250...J	205	425	42.5
TSLH120H-300...J	240	475	50.0

Note<sup>(1)</sup> : The table with bellows is 10mm higher than the table without bellows.

Remark 1: If the table with bellows is mounted in a vertical position, the dimensions of bellows are different. Please consult **IKO**.

2: For the mounting dimensions of bed, refer to the dimension table on page

# IKO Precision Positioning Table LH Table with bellows

## TSLH220H...J, TSLH320H...J, TSLH420H...J

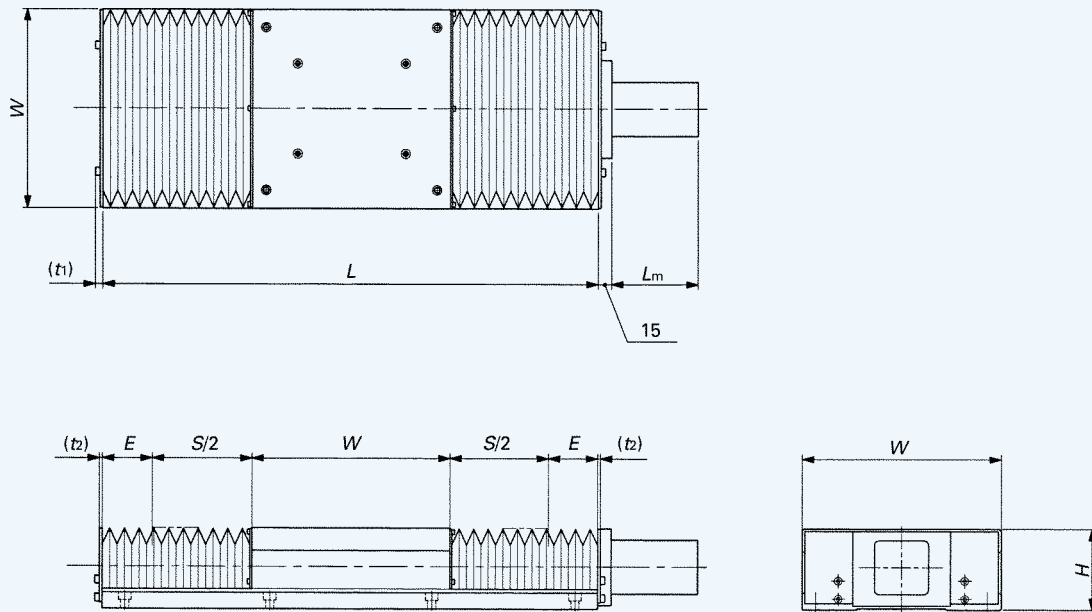

unit: mm

Model number	Stroke length $S$	Total length $L$	$W$	$H$	$E$	$t_1$	$t_2$
TSLH220H- 150...J	110	400	220	90	35	8.2	3.2
TSLH220H- 200...J	150	450			40		
TSLH220H- 250...J	180	500			50		
TSLH220H- 300...J	220	550			55		
TSLH220H- 400...J	300	650			65		
(TSLH220H- 500...J)	370	750			80		
(TSLH220H- 600...J)	440	850			95		
TSLH320H- 300...J	230	650	320	120	50	9.2	3.2
TSLH320H- 400...J	310	750			60		
TSLH320H- 500...J	400	850			65		
(TSLH320H- 600...J)	480	950			75		
(TSLH320H- 800...J)	640	1150			95		
(TSLH320H-1000...J)	800	1350			115		
TSLH420H- 500...J	410	950	420	140	60	10.5	4.5
TSLH420H- 600...J	500	1050			65		
TSLH420H- 800...J	660	1250			85		
(TSLH420H-1000...J)	830	1450			100		

Remark 1: If the table with bellows is mounted in a vertical position, the dimensions of bellows are different. Please consult **IKO**.

2: If the models in the parentheses are required, please consult **IKO**.

3: For mounting dimensions, refer to the dimension tables on pages 19 to 21.

1N=0.102kgf=0.2248lbs.  
1mm=0.03937inch



## **NIPPON THOMPSON CO., LTD.**

Head office : 19-19 Takanawa 2-chome  
Minato-ku, Tokyo 108-8586, Japan  
Phone : Tokyo (03)3448-5850  
Fax : (03)3447-7637  
E-mail : [ntt@ikonet.co.jp](mailto:ntt@ikonet.co.jp)  
URL : <http://www.ikont.co.jp/>  
Plant : Gifu, Kamakura

## **IKO International, Inc.**

- Fox Hill Ind. Park  
91 Walsh Drive  
Parsippany, NJ 07054  
U.S.A.  
Phone: (973)402-0254  
Toll Free: 1-800-922-0337  
Fax: (973)402-0441  
E-mail: [eco@ikonet.co.jp](mailto:eco@ikonet.co.jp)
- 500 East Thorndale Ave.  
Wood Dale, IL 60191  
U.S.A.  
Phone: (630)766-6464  
Toll Free: 1-800-323-6694  
Fax: (630)766-6869  
E-mail: [mwo@ikonet.co.jp](mailto:mwo@ikonet.co.jp)
- 2121 Paulhan Street  
Rancho Dominguez, CA 90220  
U.S.A.  
Phone: (310)609-3988  
Toll Free: 1-800-252-3665  
Fax: (310)609-3916  
E-mail: [wco@ikonet.co.jp](mailto:wco@ikonet.co.jp)
- 2150 Boggs Road, Suite 100  
Duluth, GA 30096  
U.S.A.  
Phone: (770)418-1904  
Toll Free: 1-800-874-6445  
Fax: (770)418-9403  
E-mail: [seo@ikonet.co.jp](mailto:seo@ikonet.co.jp)
- 8105 N. Beltline Road  
Suite 130, Irving, TX 75063  
U.S.A.  
Phone: (972)929-1515  
Toll Free: 1-800-295-7886  
Fax: (972)915-0060  
E-mail: [swo@ikonet.co.jp](mailto:swo@ikonet.co.jp)

## **Nippon Thompson Europe B.V.**

- Sheffieldstraat 35-39  
3047 AN Rotterdam  
The Netherlands  
Phone: 010-4626868  
Fax: 010-4626099  
E-mail: [nte@ikonet.co.jp](mailto:nte@ikonet.co.jp)
- Mündelheimer Weg 56  
40472 Düsseldorf  
Germany  
Phone: 0211-414061  
Fax: 0211-427693  
E-mail: [ntd@ikonet.co.jp](mailto:ntd@ikonet.co.jp)  
  
Donaustauer Str. 200  
93059 Regensburg  
Germany  
Phone: 0941-447737  
Fax: 0941-447747
- Autovia Madrid-Barcelona, Km. 43,700  
Polig. Ind. AIDA, A-8, Ofic. 2, 1<sup>a</sup>  
19200-Azuqueca de Henares  
Guadalajara, Spain  
Phone: 949-263390  
Fax: 949-263113  
E-mail: [nts@ikonet.co.jp](mailto:nts@ikonet.co.jp)
- 2 Vincent Avenue, Crownhill  
Milton Keynes Bucks MK8 OAB  
United Kingdom  
Phone: 01908-566144  
Fax: 01908-565458  
E-mail: [ntu@ikonet.co.jp](mailto:ntu@ikonet.co.jp)
- Roissypole Le Dôme  
2 rue de La Haye  
BP 10950 Tremblay en France  
95733 Roissy C. D. G. Cedex  
France  
Phone: 01-48165739  
Fax: 01-48165746  
E-mail: [ntf@ikonet.co.jp](mailto:ntf@ikonet.co.jp)

Although all data in this catalog has been carefully compiled to make the information as complete as possible, NIPPON THOMPSON CO., LTD. shall not be liable for any damages whatsoever, direct or indirect, based upon any information in this catalog. NIPPON THOMPSON CO., LTD. makes no warranty, either express or implied, including the implied warranty of merchantability or fitness for a particular purpose.