

## Valve lash adjustment elements

Product Information



# Valve lash adjustment elements



## Foreword

---

Modern engines nowadays have to satisfy far greater demands than even just 10 years ago. One of the main reasons for this is that factors such as individual mobility, the environment and the economy often contradict each other.

Hydraulic and mechanical valve lash adjustment elements from INA help to reduce drastically the consumption values of our cars.

For instance, the INA roller finger follower assembly with pivot element always guarantees precise valve clearance and a low-friction valve drive and so ensures quiet running and low pollutant emissions.

In gas and diesel engines, hydraulic and mechanical valve lash adjustment elements are subjected to a wide variety of demands, such as high speeds, vibrations and extreme temperatures. This can have a negative influence on their function. For instance, a blocked hydraulic element can lead to serious engine damage.

Our goal is to optimize our products constantly. So in our research and development centres, expert are constantly dedicated to adapting the valve lash adjustment elements to the requirements of the future through experiments and simulations.

We have set up service life and function test stands where experiments are carried out and research is performed, often together with the engine and vehicle manufacturers.

Due to INA's competence and experience in the design and production of valve lash adjustment elements, the company has for a long time been a major partner in terms of initial equipping and also in the spare parts market.

We have produced this brochure to present INA's know-how in the field of valve lash adjustment elements to our customers.

# Valve lash adjustment elements



## Table of Contents

---

<b>Product Overview</b>	Page 5
<b>Tappet, mechanical</b>	
Structure of mechanical tappets, adjusting shim at top	Page 6
Function of mechanical tappets, adjusting shim at top	Page 7
Structure of mechanical tappets, adjusting shim at bottom	Page 8
Function of mechanical tappets, adjusting shim at bottom	Page 9
<b>Tappet, hydraulic</b>	
Structure of hydraulic tappet	Page 10
Function	Page 11
Installation example	Page 13
Possible causes of failure	Page 14
Checking hydraulic tappet	Page 15
<b>Roller finger follower assembly with hydraulic pivot element</b>	
Structure of finger follower assembly with hydraulic pivot element	Page 16
Function	Page 17
Installation example	Page 19

# Valve lash adjustment elements



## Table of Contents

---

Possible causes of failure	Page 20
Checking hydraulic pivot element	Page 21
<b>Rocker arm with hydraulic plug-in element</b>	
Structure of rocker arm with hydraulic plug-in element	Page 22
Function	Page 23
Installation example	Page 25
Possible causes of failure	Page 26
Checking hydraulic plug-in element	Page 27
<b>Simulation and measuring test stands at INA</b>	Page 28
<b>General workshop instructions for replacing hydraulic valve lash adjustment elements</b>	Page 30
<b>Further information</b>	Page 33

# Valve lash adjustment elements



## Product designations and abbreviations

---

ASEH	Pivot element, hydraulic
ASHB	Support plate
ES	Adjusting shim
KEEH	Rocker arm element
KIPH	Rocker arm, hydraulic
KIPM	Rocker arm, mechanical
KIT SLH	Finger follower assembly kit, consisting of finger follower assembly and pivot element
RSSH	Roller type tappet, switchable
RSTH	Roller type tappet, hydraulic
RSTM	Roller type tappet, mechanical
SLH	Finger follower assembly
SWIH	Swinger arm, hydraulic
SWIM	Swinger arm, mechanical
TSTH	Tappet, hydraulic
TSTHA	Tappet, hydraulic, anti-drain type
TSTHI	Tappet, hydraulic, with low suction
TSTHL	Tappet, hydraulic, anti-drain type with low suction, sheet metal labyrinth
TSTM	Tappet, mechanical

# Tappet, mechanical

## Adjusting shim (ES), top



Camshaft	1
Adjusting shim, top	2
Valve spring	3
Tappet TSTM	4
Valve	5

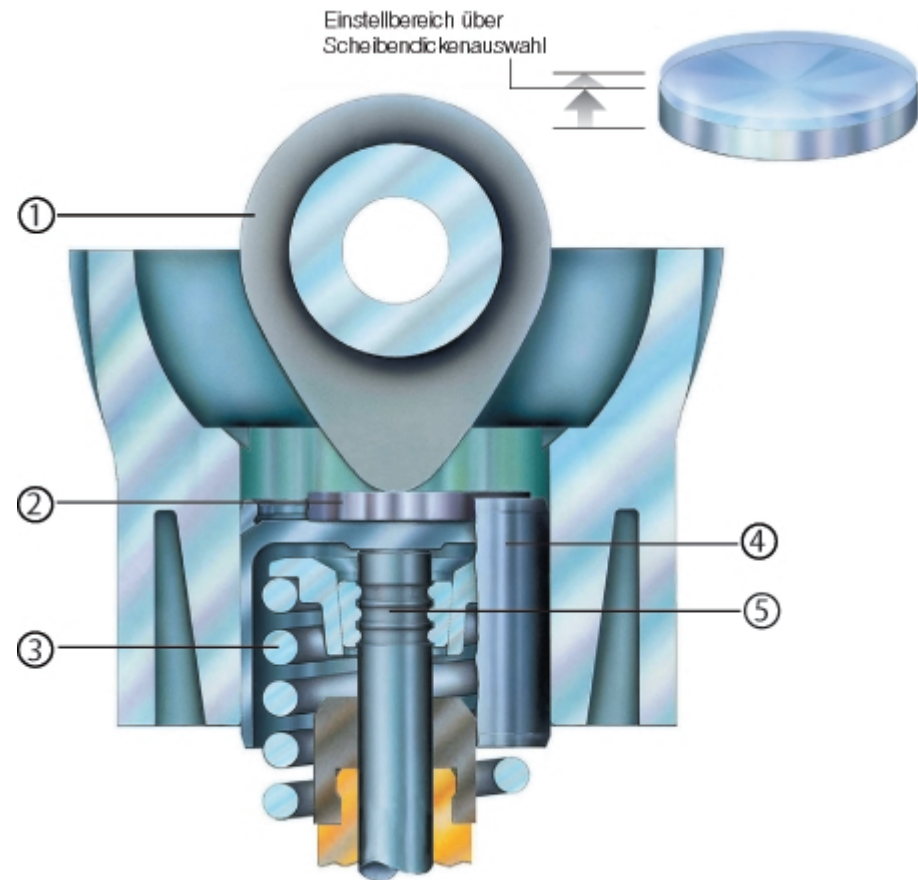

# Tappet, mechanical



## Adjusting shim, top: Function

---

1. Compensation of all production tolerances between the basic circuit and the valve seat through adjusting shims of various thicknesses during initial installation.
2. After adjustment, a defined basic clearance must still be present between the basic cam circuit and the adjusting shim.
3. A defined basic clearance is necessary to compensate for changes in the length of the valve drive due to heat expansion and setting or wearing procedures.
4. If the valve clearance becomes too great or too small during the maintenance interval, the adjusting shim and the cup must be replaced (it is not necessary to remove the camshaft!).

# Tappet, mechanical



## Adjusting shim, bottom

- Camshaft 1
- Adjusting shim, bottom 2
- Valve spring 3
- Tappet (TSTM) 4
- Valve 5

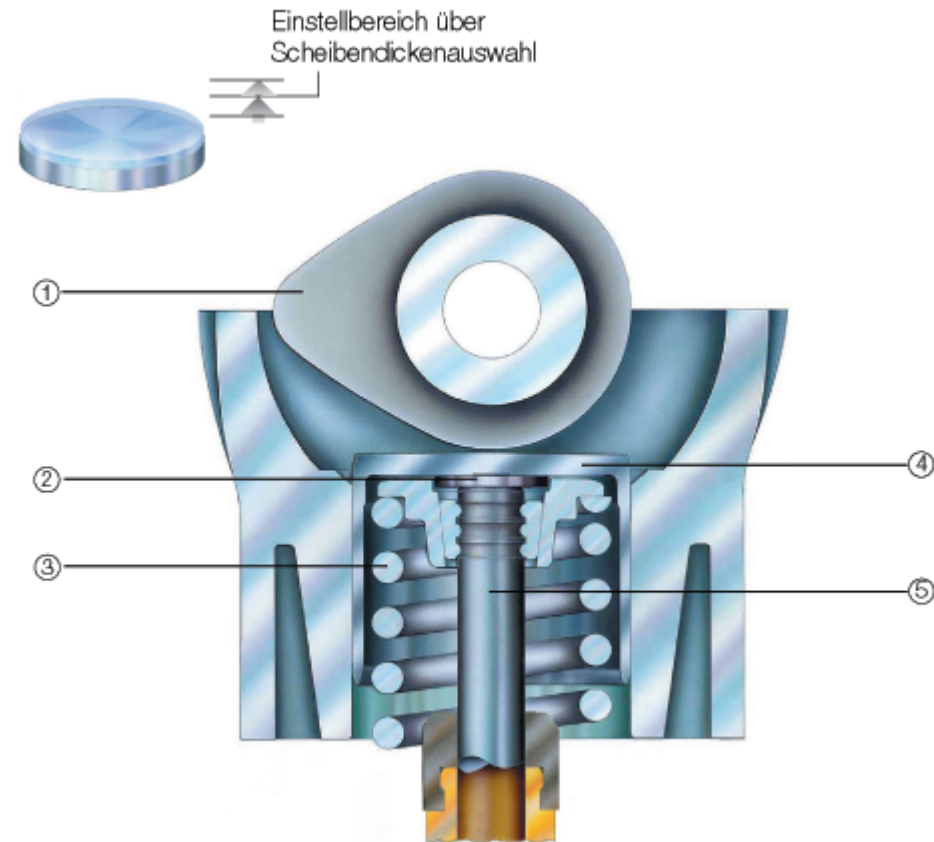



# Tappet, mechanical



## Adjusting shim, top: Function

---

1. Compensation of all production tolerances between the basic circuit and the valve seat through adjusting shims of various sizes during initial installation.
2. After adjustment, a defined basic clearance must still be present between the basic cam circuit and the outer base of the cup.
3. A defined basic clearance is necessary to compensate for changes in the length of the valve drive due to heat expansion and setting or wearing procedures.
4. If the valve clearance becomes too great or too small during the maintenance interval, the adjusting shim and the cup must be replaced (it is necessary to remove the camshaft!).

# Tappet, hydraulic

## Structure



- Cup housing 1
- Housing inner part 2
- Cylinder part 3
- Piston 4
- Return spring 5
- Valve spring 6
- Valve cap 7
- High-pressure area 8
- Ball 9

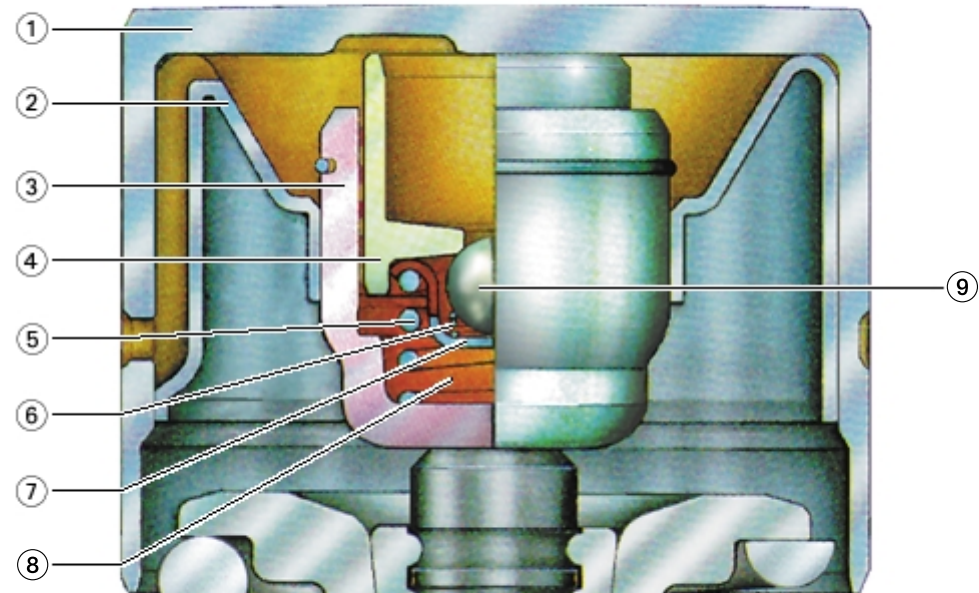

# Tappet, hydraulic



## Function

### Lowering procedure (cam stroke)

- Tappet is loaded by engine valve spring force and inertial forces.
- Distance between the piston and the inner housing is reduced.  
As a result, a small quantity of oil is pressed out of the high-pressure area through the leakage gap ① and is fed back into the oil reservoir ②
- A minimal clearance develops in the valve drive at the end of the lowering procedure.
- A low quantity of oil and air is pressed out through the inlet bore and / or the guide gap ③

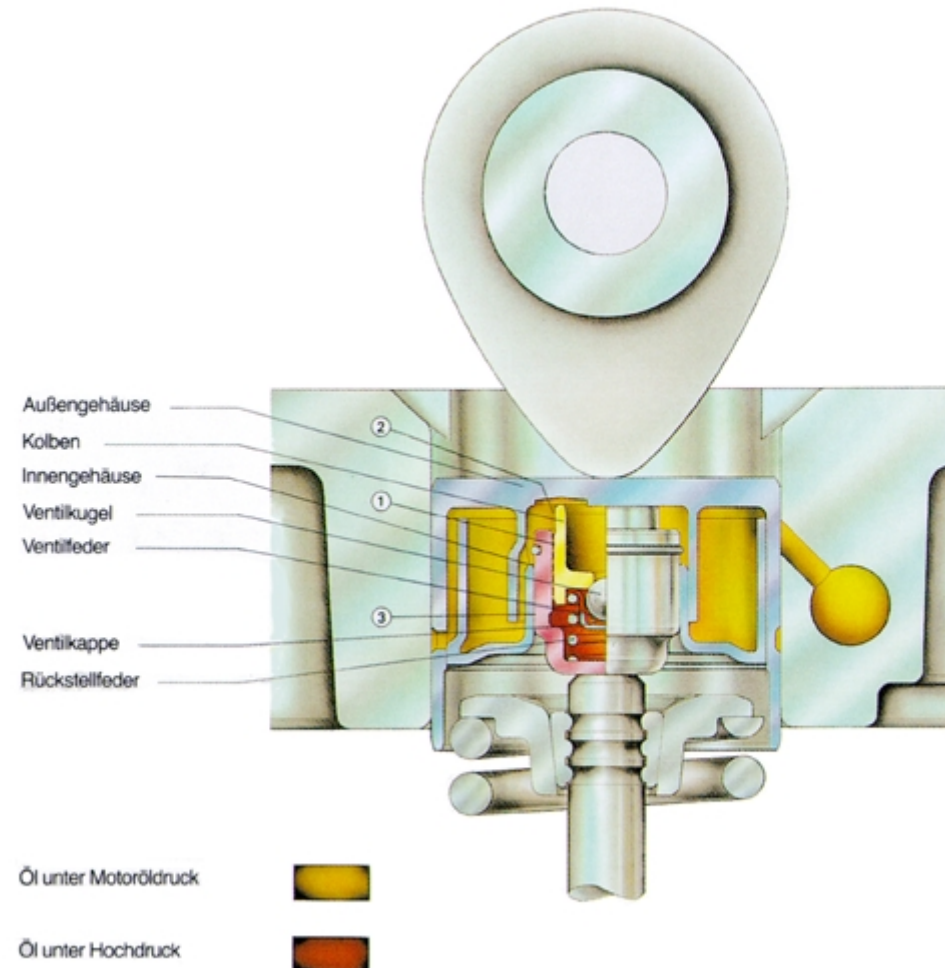

# Tappet, hydraulic



## Function

### Compensation procedure (basic circuit)

- Return spring presses the piston and the inner housing apart until valve clearance is compensated.
- Ball non-return valve opens due to the pressure difference between the high-pressure area and the oil reservoir (piston). Oil flows out of the oil reservoir (outer housing) via the oil overflow, the oil reservoir (piston) and the ball non-return valve in the high-pressure area ④.
- The ball non-return valve closes, the frictional connection in the valve drive is re-established.

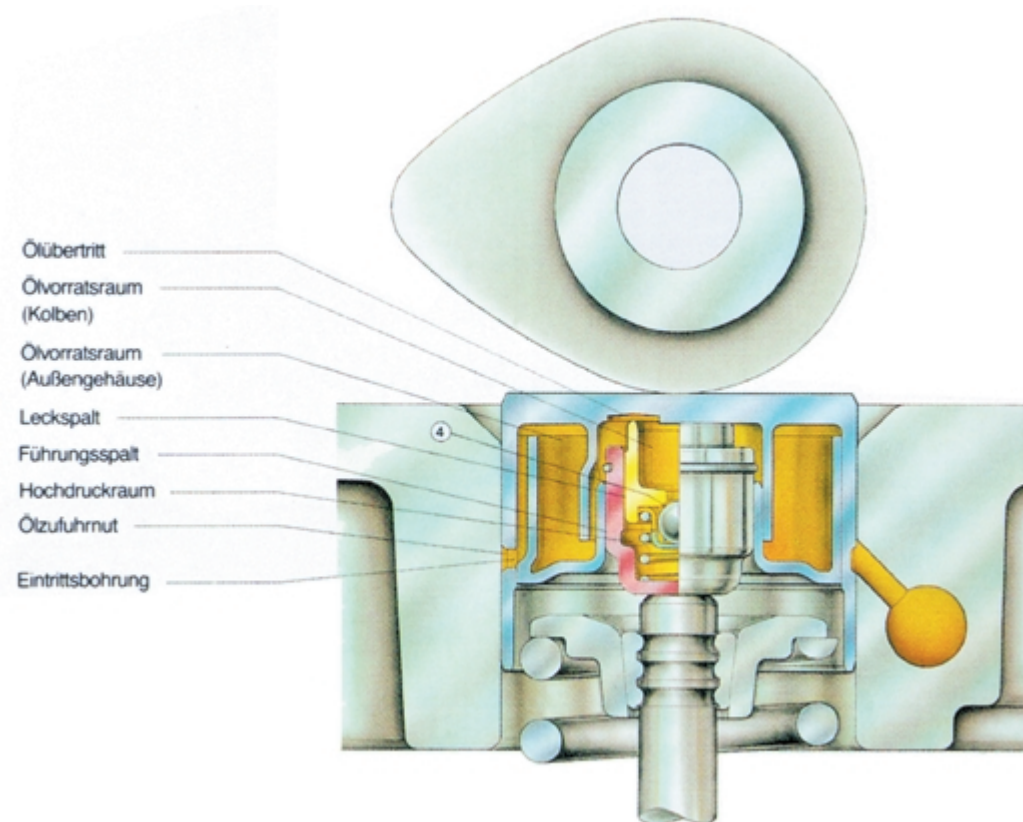

# Tappet, hydraulic

## Installation example



- 1 Hydraulic tappet
- 2 Valve spring wedge
- 3 Valve spring seat
- 4 Valve spring seal
- 5 Valve spring
- 6 Spring seat
- 7 Valve guide
- 8 Camshaft

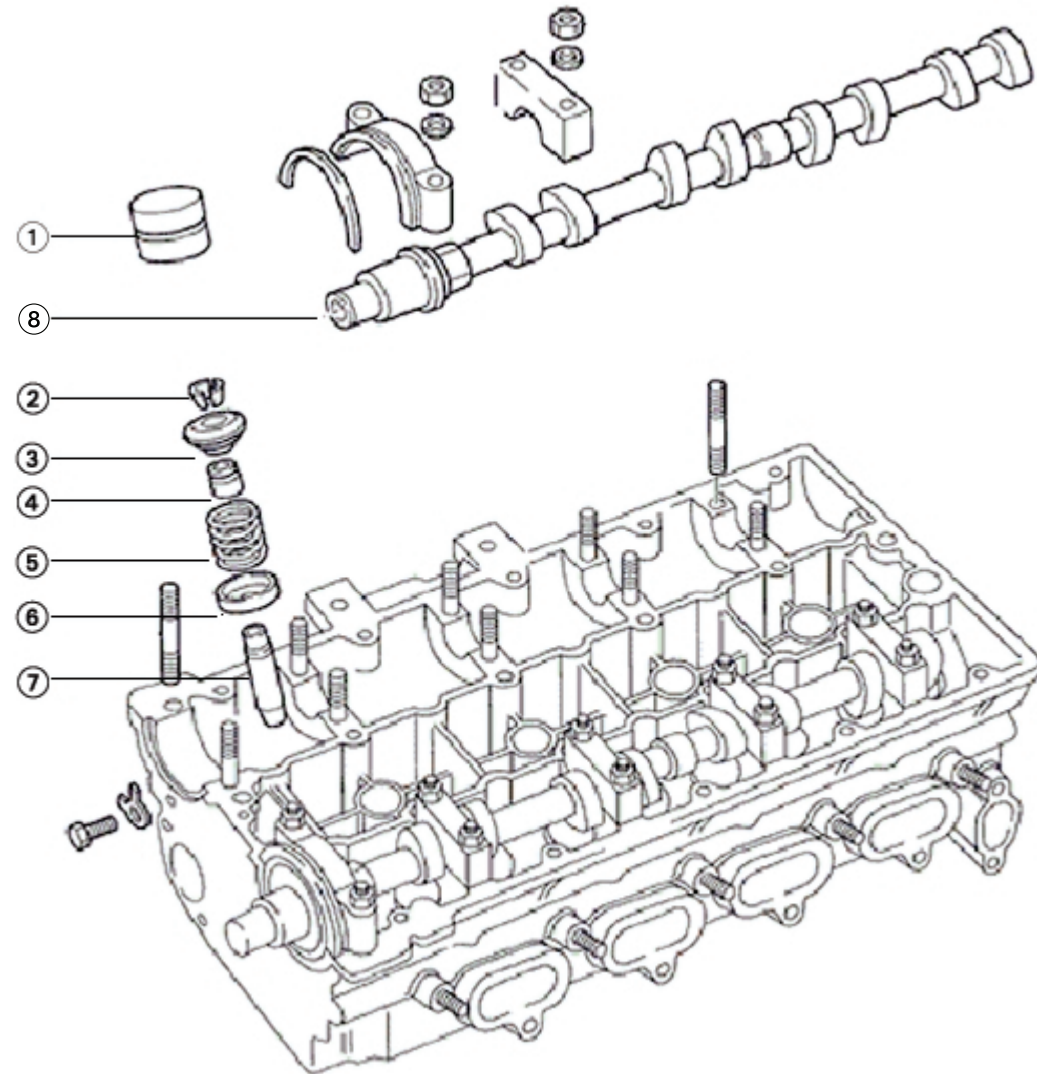

# Tappet, hydraulic



## Possible causes of failure

**The most frequent damage to the tappet occurs in the following position:**

- Camshaft
- Cup base ①
- Cup shroud ②
- Valve support area ③
- Piston of the HEV element (hydraulic element)
- Housing of the HEV element (hydraulic element)
- Ball valve
- Return spring

### Causes of failure:

- Inadequate lubrication / oil quantity too low
- Oil foaming / oil quantity too great
- Poor oil quality / impurities in the oil
- Assembly error during installation

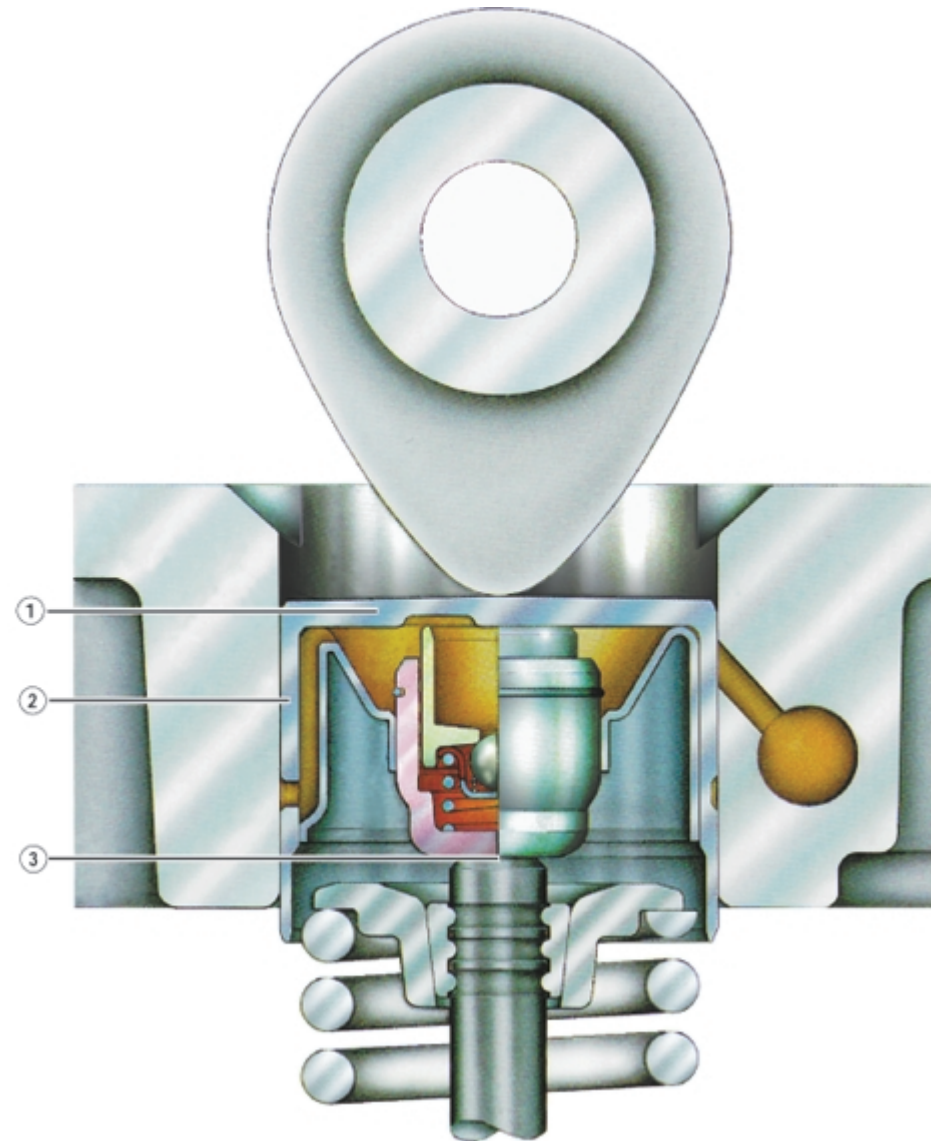

# Tappet, hydraulic

## Tests



Noises in the valve drive may occur in certain operating conditions (multiple start, cold start) and after replacing the tappets. The valve drive noises should be remedied by quickly bleeding the hydraulic element high-pressure areas and reservoirs. When bleeding, you must observe the regulations of the relevant car manufacturers without fail.

If the valve drive noise is still present, please carry out the following tests:

1. Remove the valve cover.
2. Check the tappets located in the basic circuit (valve totally closed) for
  - a) softness - apply pressure to the tappet briefly several times with a thumb or a screwdriver. Indication of air in high-pressure area: springy compliance;
  - b) non-return valve defective - as under a), but apply greater force for longer (approx. 10...15 sec.). Indication: clearance appears during load, disappears when load removed;
  - c) clearance (element jams) - with feeler gauge (between element and basic cam circuit).
3. Replace conspicuous (defective) tappets.

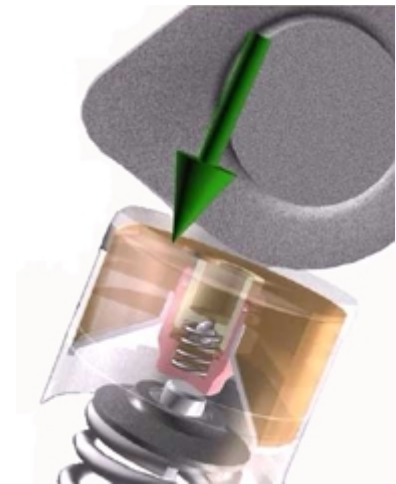

# Roller finger follower assembly with hydr. pivot element

## Structure



- 1 Housing
- 2 Piston
- 3 Ball
- 4 Spiral spring
- 5 Retaining cap
- 6 High-pressure area
- 7 Return spring

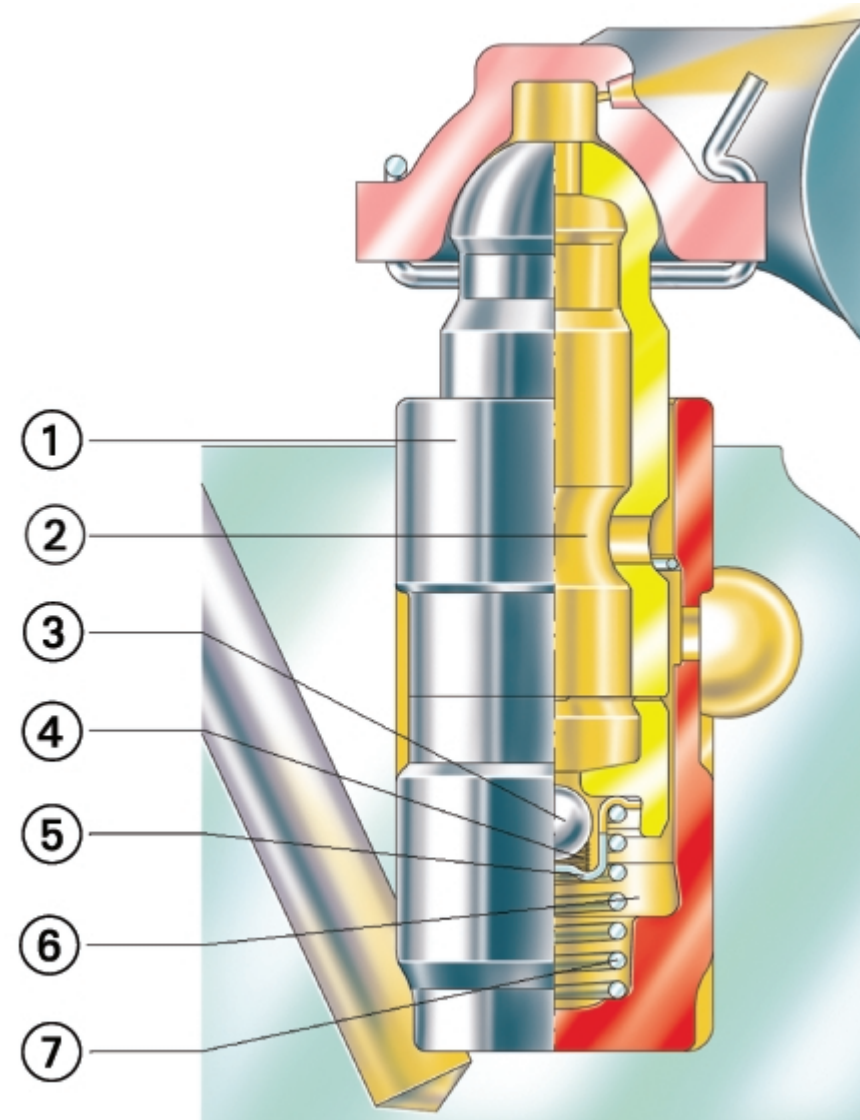
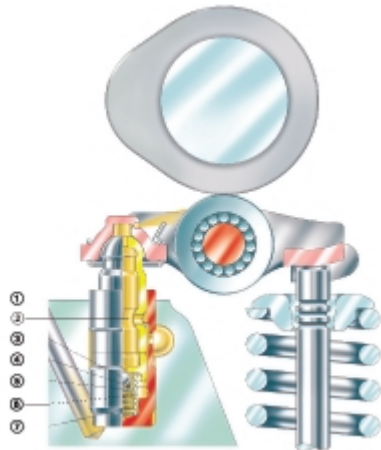



# Roller finger follower assembly with hydr. pivot element

## Function



### Lowering procedure (cam stroke)

- Tappet is loaded by engine valve spring force and inertial forces.
- Distance between the piston and the housing is reduced.  
As a result, a small quantity of oil is pressed out of the high-pressure area through the leakage gap ① and is fed back into the oil reservoir through the leaking oil collection groove and the inlet bore ②
- A minimal clearance in the valve drive develops at the end of the lowering procedure.
- A low quantity of oil and air is pressed out through the bleed bore and the leakage gap ③

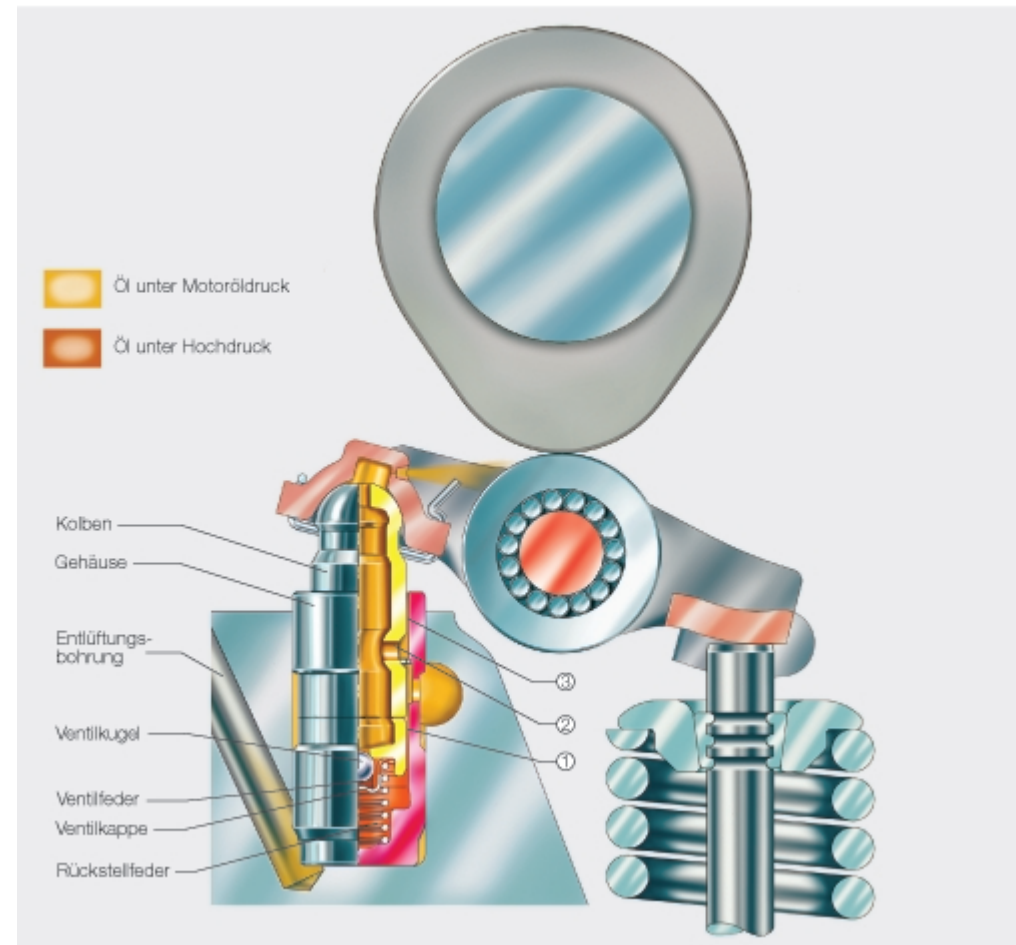

# Roller finger follower assembly with hydr. pivot element

## Function



### Compensation procedure (basic circuit)

- Return spring presses the piston and the housing apart until valve clearance is compensated.
- Ball non-return valve opens due to the pressure difference between the high-pressure area and the oil reservoir . Oil flows out of the oil reservoir via the ball non-return valve in the high-pressure area ④ .
- The ball non-return valve closes, the frictional connection in the valve drive is re-established.

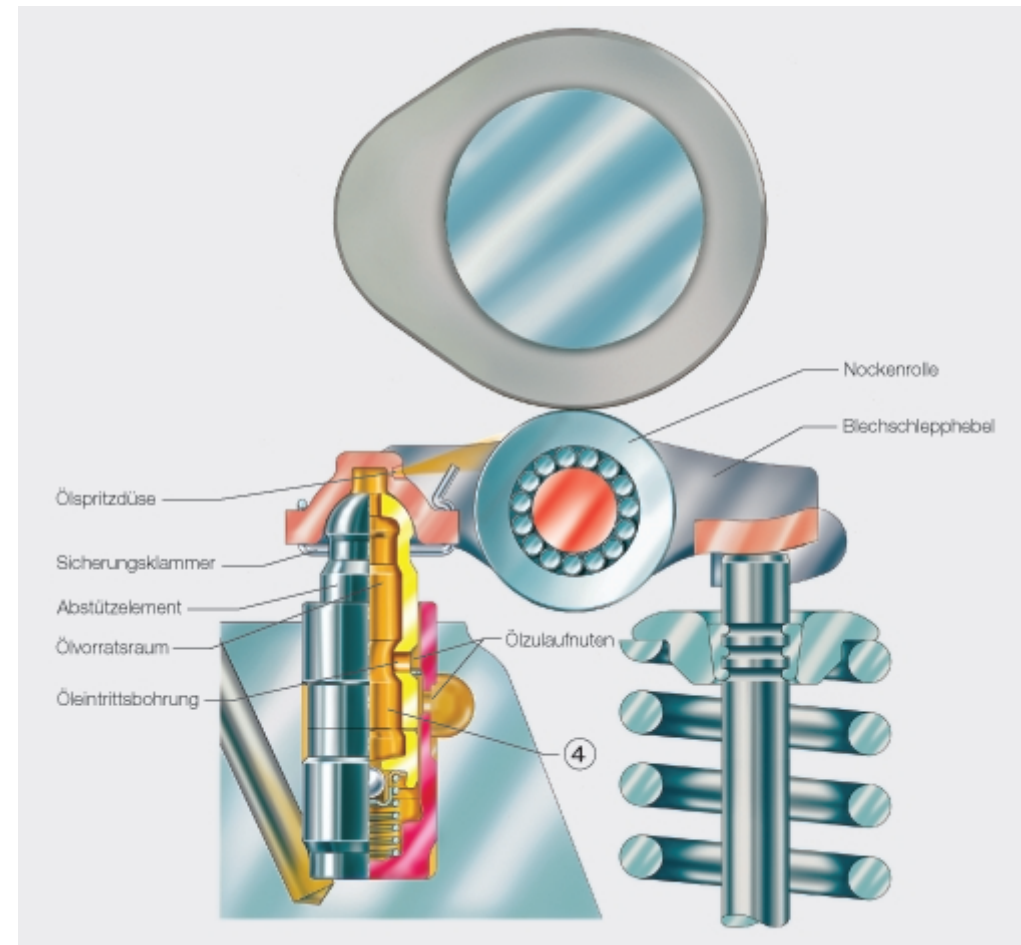

# Roller finger follower assembly with hydr. pivot element

## Installation example



- 1 Valve spring wedge
- 2 Valve spring seat
- 3 Valve spring
- 4 Valve spring seal
- 5 Finger follower assembly
- 6 Hydr. pivot element
- 7 Valve

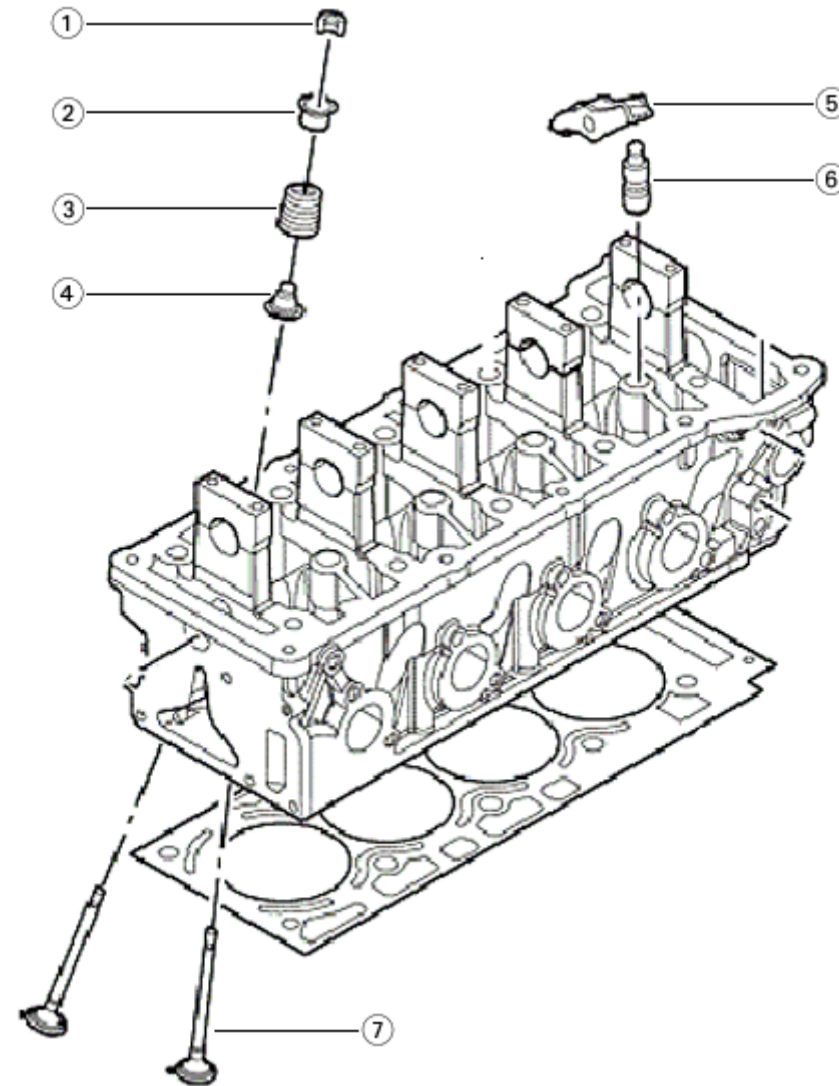
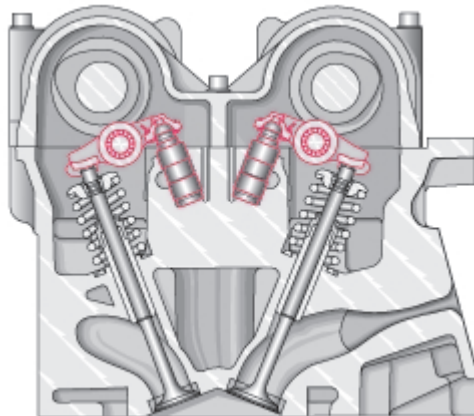

# Roller finger follower assembly with hydr. pivot element

## Possible causes of failure



**The most frequent damage to the finger follower assembly occurs in the following position:**

- Camshaft
- Contact: Finger follower assembly - pivot element ①
- Contact: Finger follower assembly - valve ②
- Piston of the HEV element (hydraulic element)
- Housing of the HEV element (hydraulic element)
- Ball valve
- Return spring

### Causes of failure:

- Inadequate lubrication / oil quantity too low
- Oil foaming / oil quantity too great
- Poor oil quality / impurities in the oil
- Assembly error during installation
- Wear at the contact point between the calotte of the finger follower assembly and the head of the pivot element

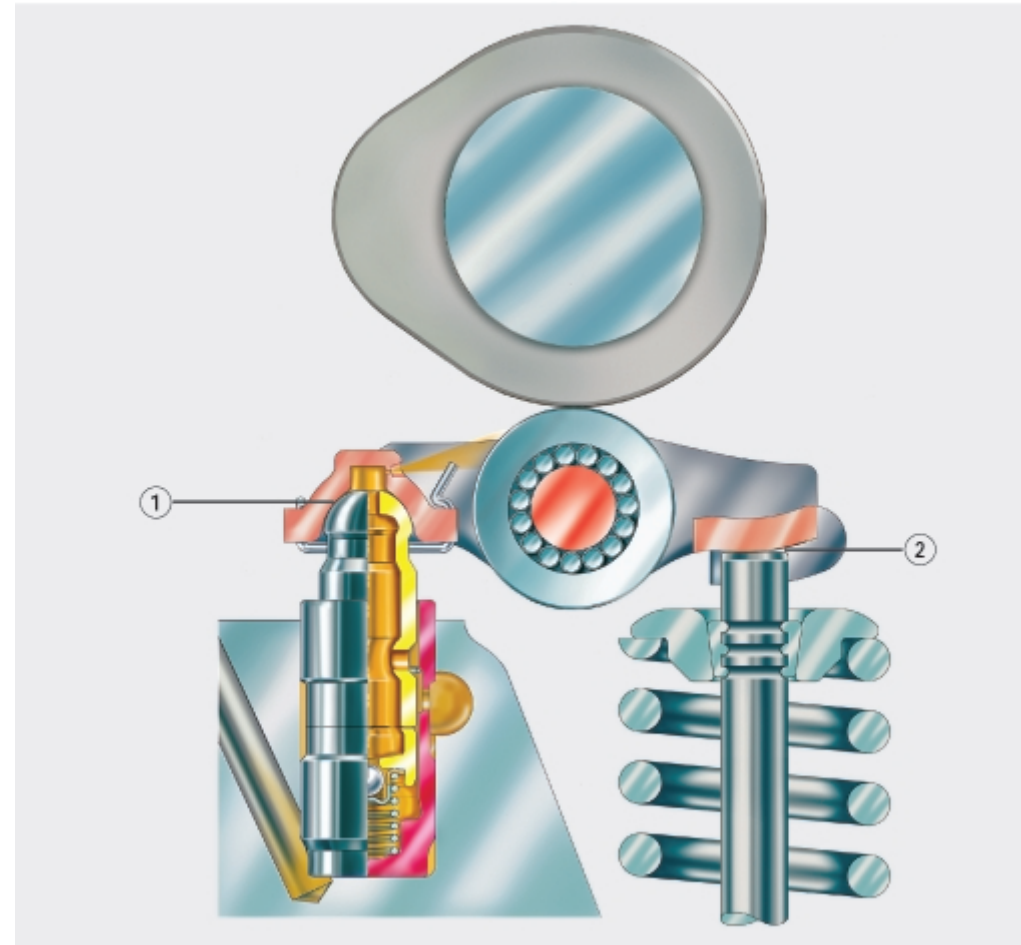

# Roller finger follower assembly with hydr. pivot element

## Tests

---



Noises in the valve drive may occur in certain operating conditions (multiple start, cold start) and after replacing the hydr. pivot elements. The valve drive noises should be remedied by quickly bleeding the hydraulic element high-pressure areas and reservoirs. When bleeding, you must observe the regulations of the relevant car manufacturers without fail.

If the valve drive noise is still present, please carry out the following tests:

1. Remove the valve cover.
2. Check the hydraulic adjustment element. During this check, the element must be located in the basic circuit, i.e. the valve must be closed fully.
  - a) Find out the clearance between the cam and the finger follower assembly by pressing the finger follower assembly downward with a wooden or plastic wedge. If a feeler leaf gauge can be pushed 0.20 mm between the camshaft and the finger follower assembly, replace the hydraulic adjustment elements.

# Rocker arm with hydr. plug-in element



## Structure

- 1 Support plate
- 2 Piston
- 3 Retaining cap
- 4 Housing
- 5 Valve ball
- 6 Valve spring
- 7 Return spring
- 8 Retaining cage
- 9 Guide shoe

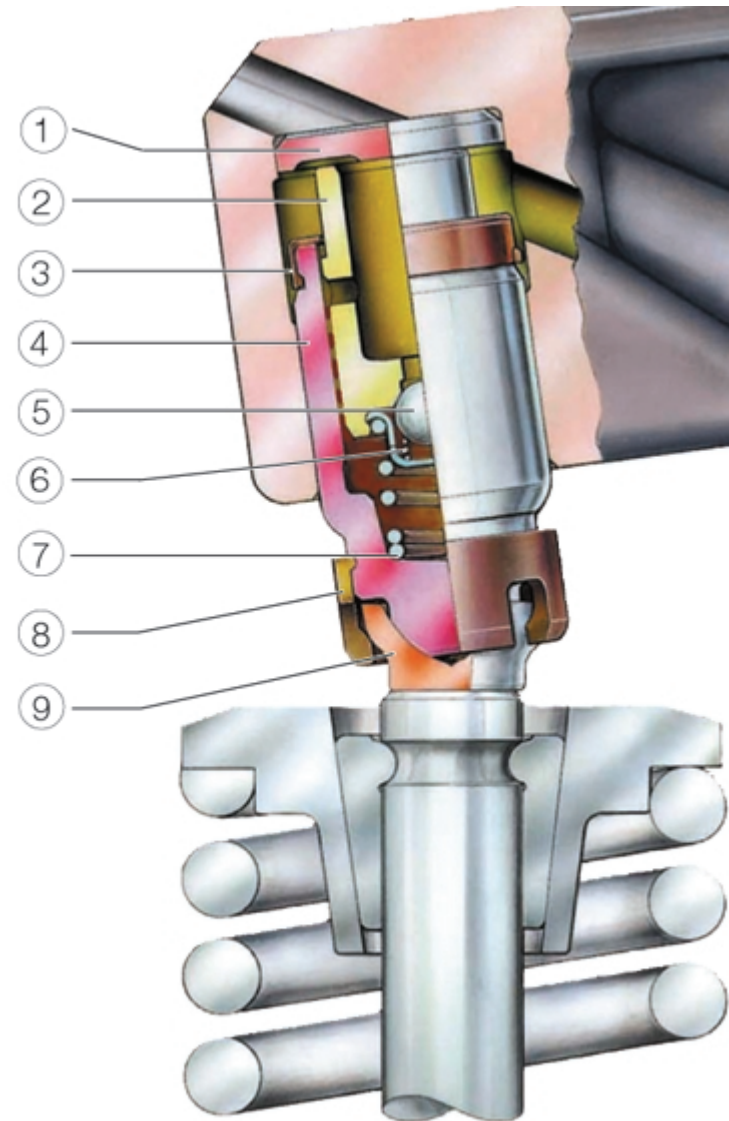
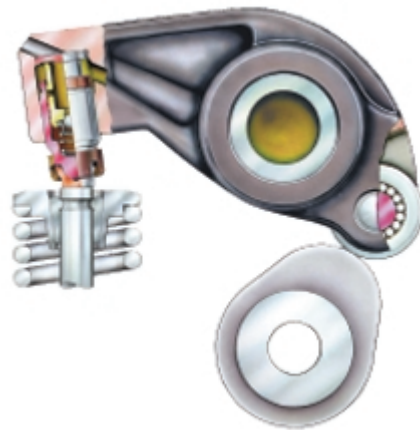

# Rocker arm with hydr. plug-in element



## Function

### Lowering procedure (cam stroke)

- Plug-in element is loaded by engine valve spring force and inertial forces.
- Distance between the piston and the housing is reduced.  
As a result, a small quantity of oil is pressed out of the high-pressure area through the leakage gap ① and is fed back into the oil reservoir through the leaking oil collection groove and the inlet bore ②
- A minimal clearance develops in the valve drive at the end of the lowering procedure.
- A low quantity of oil and air is pressed out through the inlet bore and the leakage gap ③

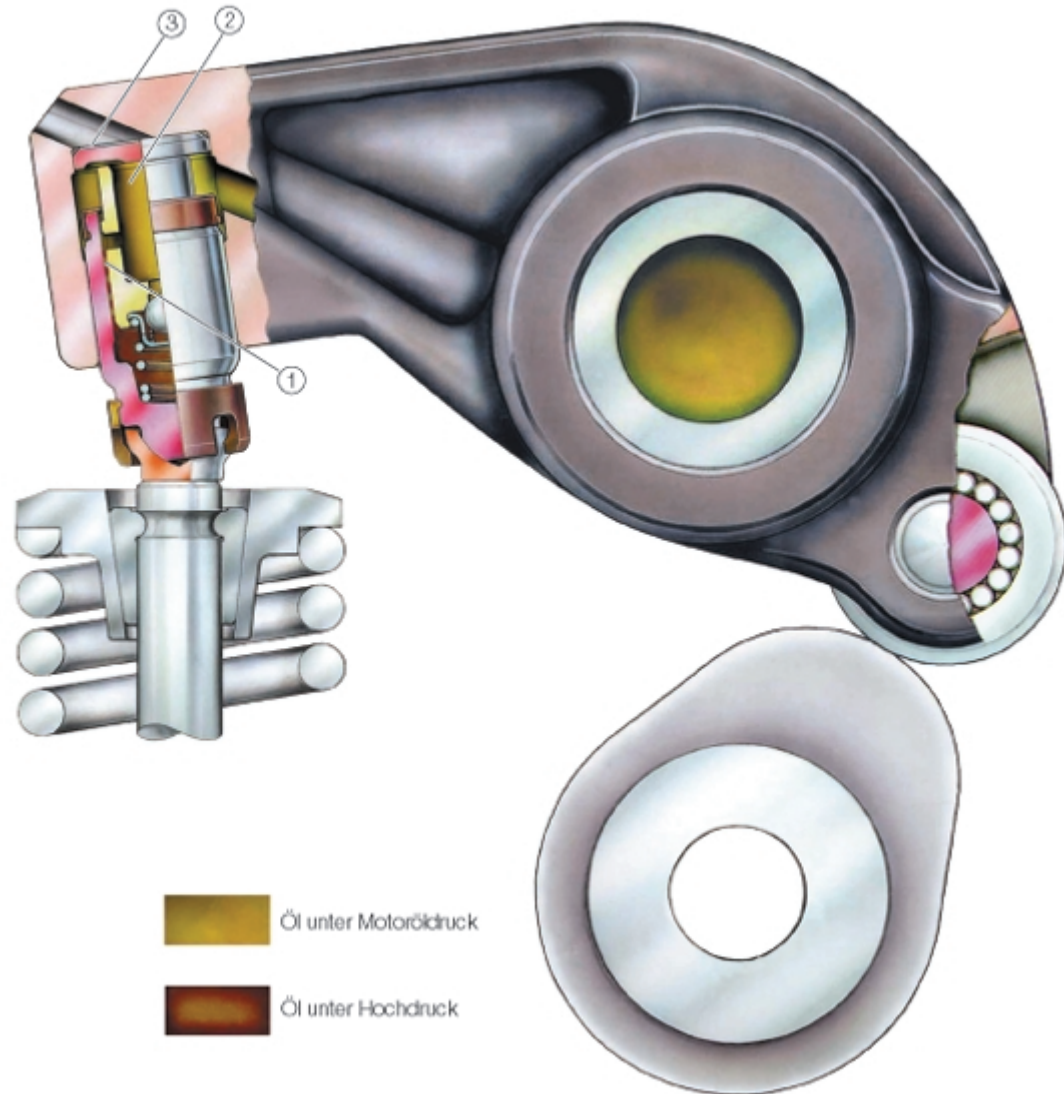

# Rocker arm with hydr. plug-in element



## Function

### Compensation procedure (basic circuit)

- Return spring presses the piston and the housing apart until valve clearance is compensated.
- Ball non-return valve opens due to the pressure difference between the high-pressure area and the oil reservoir . Oil flows out of the oil reservoir via the ball non-return valve in the high-pressure area ④ .
- The ball non-return valve closes, the frictional connection in the valve drive is re-established.

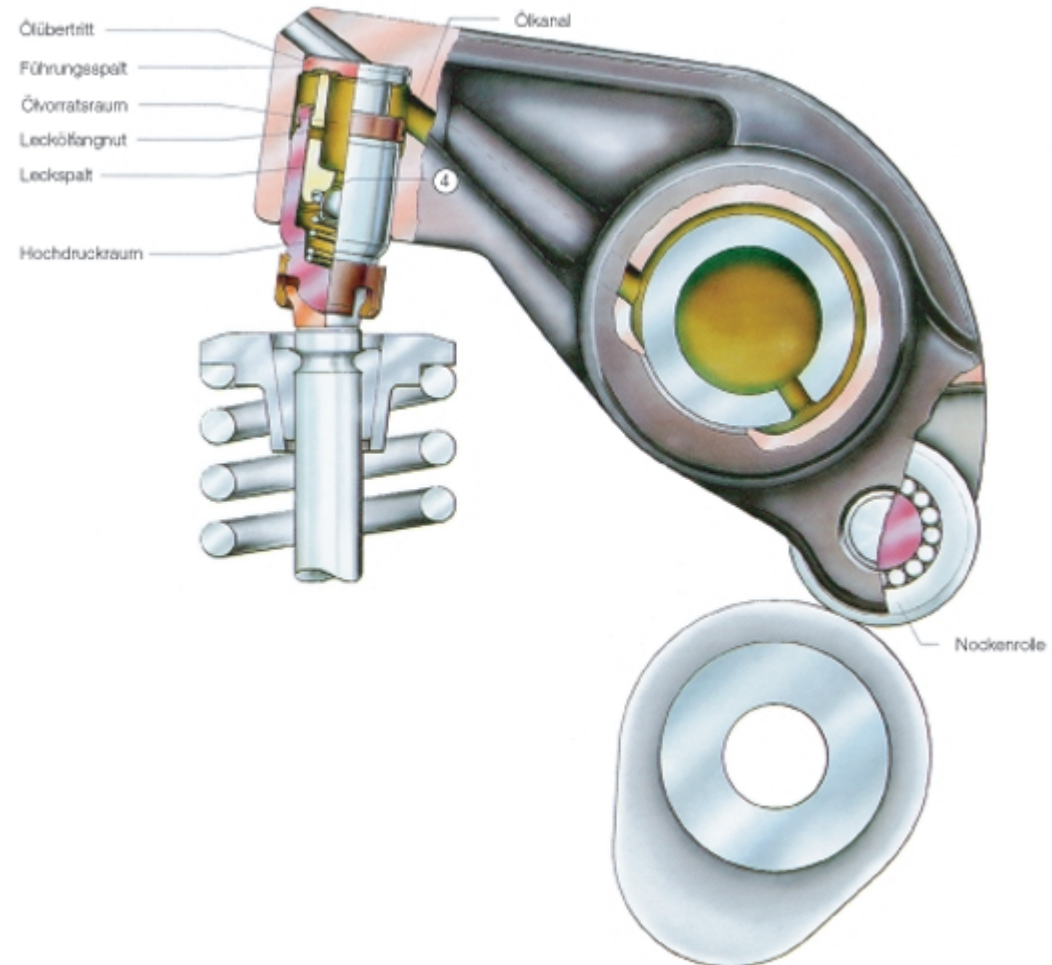



# Rocker arm with hydr. plug-in element



## Installation example

- 1 Rocker arm axis
- 2 Rocker arm
- 3 Hydr. plug-in element
- 4 Valve spring seal

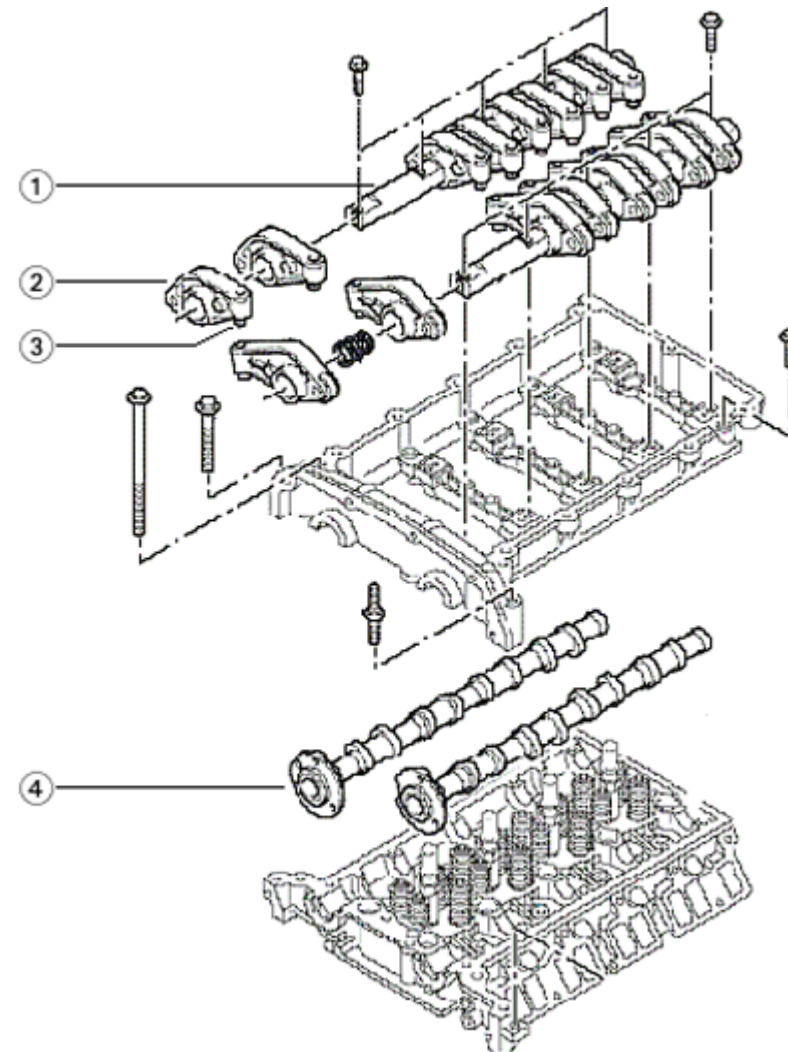
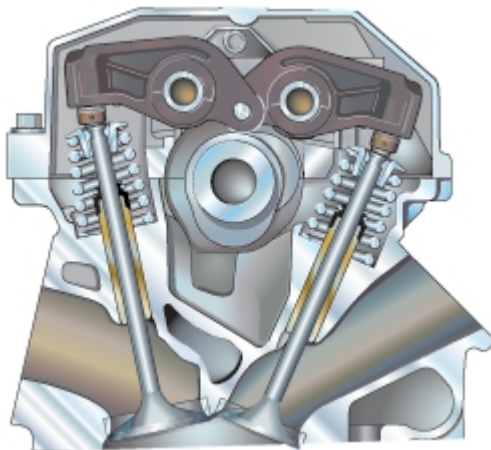

# Rocker arm with hydr. plug-in element



## Possible causes of failure

**The most frequent damage to the rocker arm occurs in the following position:**

- Camshaft
- Contact: Rocker arm - plug-in element ①
- Contact: Rocker arm - valve ②
- Piston of the HVA element (hydraulic element)
- Housing of the HVA element (hydraulic element)
- Ball valve
- Return spring

### Causes of failure:

- Inadequate lubrication / oil quantity too low
- Oil foaming / oil quantity too great
- Poor oil quality / impurities in the oil
- Assembly error during installation

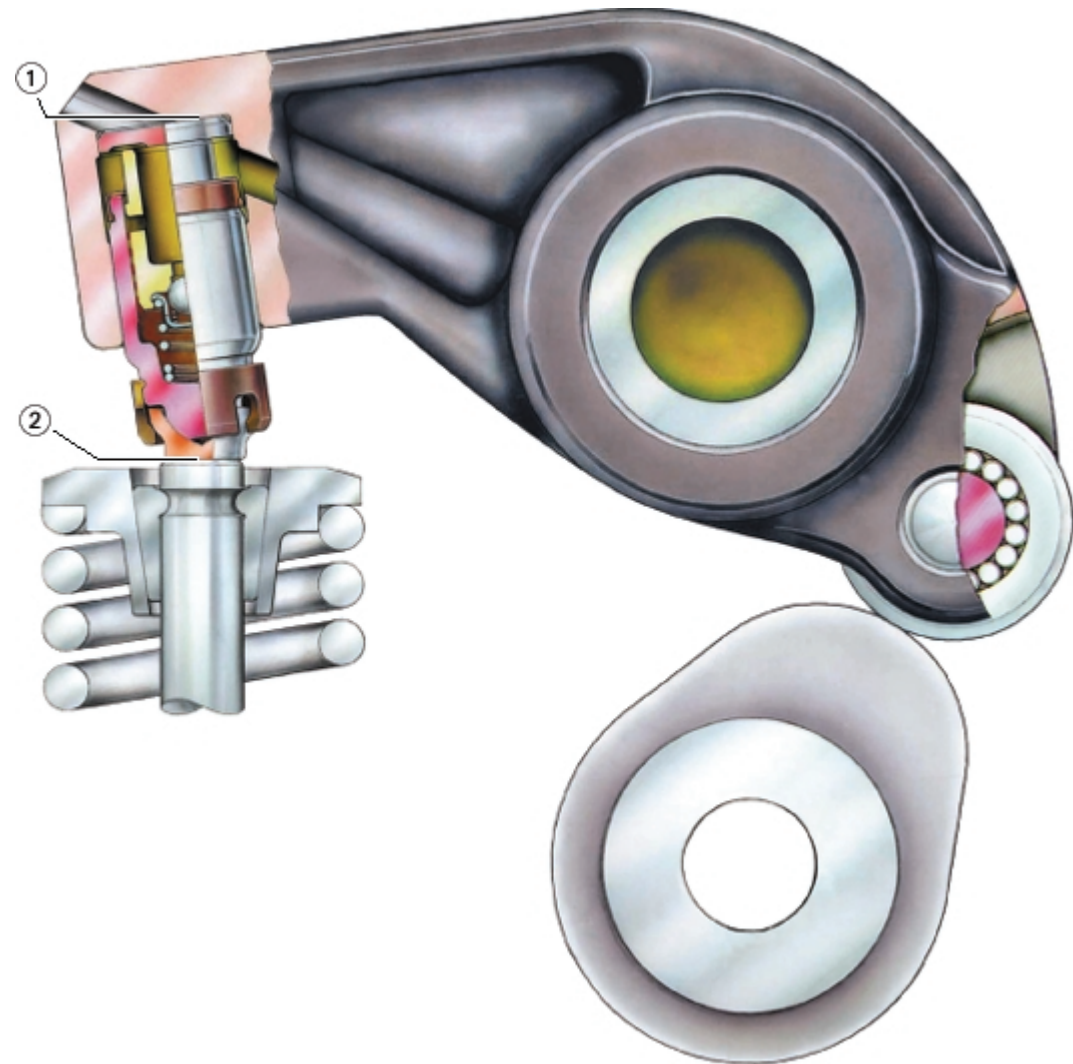

# Rocker arm with hydr. plug-in element

## Check rocker arm with hydraulic plug-in element

---



Noises in the valve drive may occur in certain operating conditions (multiple start, cold start) and after replacing the hydr. plug-in elements. The valve drive noises should be remedied by quickly bleeding the hydraulic element high-pressure areas and reservoirs. When bleeding, you must observe the regulations of the relevant car manufacturer without fail.

If the valve drive noise is still present, please carry out the following tests:

1. Remove the valve cover.
2. Check the hydraulic plug-in element. During this check, the element must be located in the basic circuit, i.e. the valve must be closed fully.
  - a) Find out the clearance between the cam and the rocker arm by pressing the rocker arm downward with a wooden or plastic wedge. If a feeler leaf gauge can be pushed 0.20 mm between the camshaft and the rocker arm, replace the hydraulic plug-in elements.

# Valve lash adjustment elements



## Simulation and measuring test stands at INA

### Experiment: Noise investigations under extreme conditions:

Investigation of hydraulic valve lash adjustment elements in running engines.

### Procedure:

Valve drive noises may indicate a malfunction in the hydraulic valve lash adjustment elements. This malfunction may occur under extreme conditions, if the oil supply is not guaranteed correctly.

Therefore 3 different experiments are carried out:

1. Cold start
2. Hot idling
3. Brief start test (taxi test)

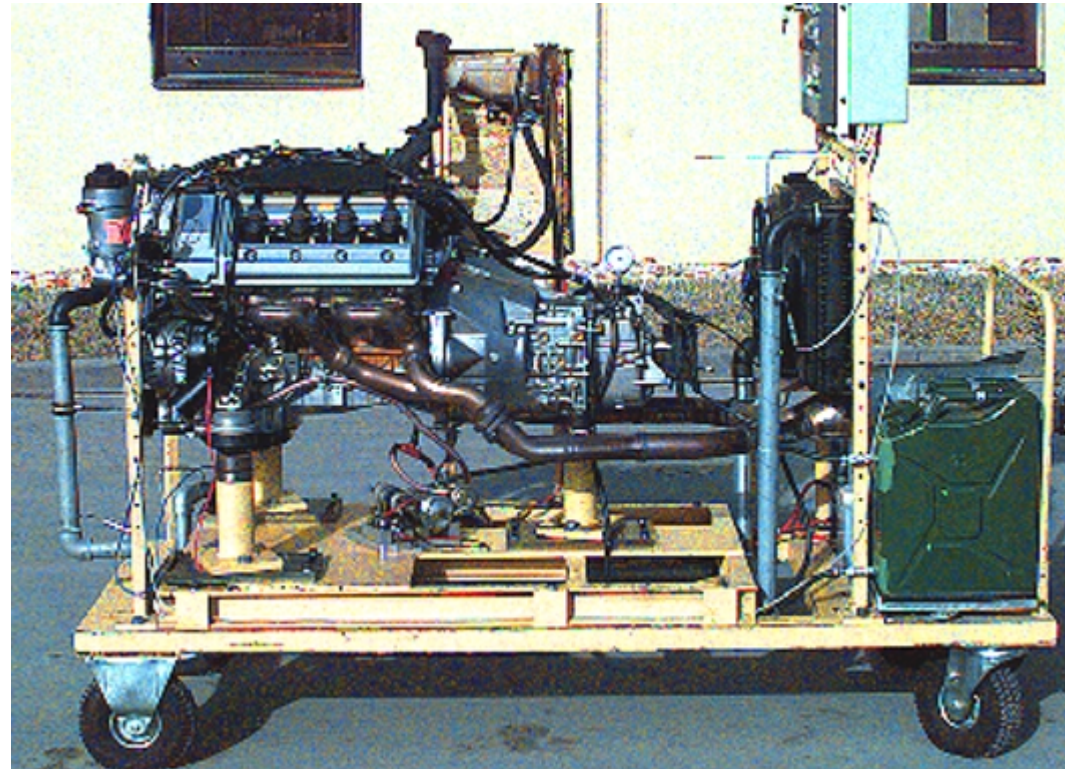

# Valve lash adjustment elements



## Simulation and measuring test stands at INA

### Valve drive dynamics experiment

#### Aim:

Investigation of the dynamic behavior of the valve drive and wear investigations.

#### Procedure:

The camshaft is driven by an electric motor. The oil pressure, temperature and oil foaming can be set appropriately with an external oil aggregate.

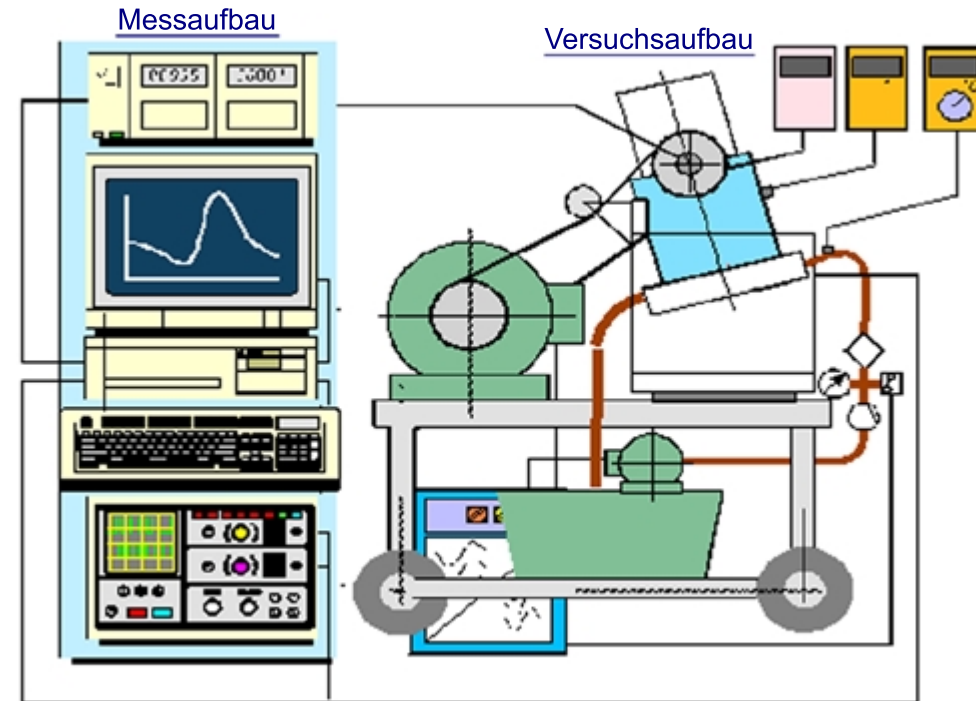

# Valve lash adjustment elements



## General workshop instructions and recommendations

---

These generally accepted workshop tips are recommended for the installation of hydraulic adjustment elements on the valve drive and correspond to preventive maintenance measures.

### 1) Replacement after 120,000 km

When overhauling an engine with a mileage of over 120,000 km, the hydraulic valve lash adjustment elements should be replaced. Due to the narrow tolerances and the high ambient temperatures present in the engine, the wear limit of the hydraulic elements has usually been reached or exceeded after a service life of this length.

### 2) Always replace in sets

If there is a defect in one or several hydraulic adjustment elements, always replace the entire set. For instance, if a pivot element is fitted with a finger follower assembly that has not been replaced, there will be a poor contact between the calotte of the finger follower assembly and the head of the pivot element, which will lead to wear.

# Valve lash adjustment elements



## General workshop instructions and recommendations

---

### 3) Filling hydraulic elements

The hydraulic adjustment elements on the spare parts market are sometimes filled with the prescribed volume of oil ex factory or they are supplied with enough oil for the running-in period.

This guarantees that the height of the hydraulic piston will automatically be set to the correct level when the overhauled engine is started up for the first time.

The adjustment elements will bleed themselves during this period, but in comparison to the filled elements they will cause some ticking noises in the area of the cylinder head, until the required quantity of oil has been filled in by the engine oil circuit.

### 4) General instruction for installation

- a) Drain off engine oil.
- b) Clean the oil system, especially the oil ducts to the hydraulic elements, if necessary remove and clean the oil pan and the oil screen.
- c) Install new oil filter.
- d) Top up oil level and check the oil supply.

# Valve lash adjustment elements



## General workshop instructions and recommendations

---

### 5) Recommendation to bleed the valve lash adjustment elements in the engine

Noises in the valve drive may occur in certain operating conditions (multiple start / cold start / first engine installation). If the following recommendations are followed, a quick bleeding of the hydraulic element high-pressure areas and the reservoirs can be guaranteed:

1. If valve drive noises occur after the first engine start (initial installation), a normal engine start or during hot idling, the engine should be allowed to run for approx. 4 min. at a constant speed of approx. 2500 rpm or at alternating speeds between 2000 and 3000 rpm.
2. There must then be an idling period of approx. 30 sec.
3. If no valve drive noises are audible after 1. and 2., the hydraulic element has been bled. If valve drive noises are still perceptible, repeat the cycle of steps 1. and 2.
4. It can be assumed that 90% of all occurring cases will be solved with the first cycle.
5. In certain individual cases, it may be necessary to repeat the cycle up to 5 or 6 times.
6. If the valve drive noises are still clearly audible after step 5., it is recommended to replace the affected elements.



# Valve lash adjustment element



## Further information

---

If you require further information, please contact:

## **INA Wälzlager Schaeffler oHG**

Automotive Aftermarket World-Wide

Industriestraße 1-3

91074 Herzogenaurach

Telephone: +49 (0) 9132 / 82 - 2523

Fax: +49 (0) 9132 / 82 - 4903