



KAMATICS CORPORATION

MARINE

BEARINGS















Kamatics Corporation
1330 Blue Hills Avenue
Bloomfield Connecticut USA 06002-0003
Phone: 860 243-9704, Fax: 860 243-7993

KARON Lined Spherical Bearings, Rod Ends and Journal Bearings

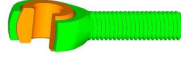
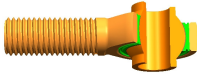
Please review the Kamatics KArOn Design Guide and "Spherical Bearing" section of this catalog for information about the Kamatics design approach to solving the more common problems associated with fabric lined spherical bearings, including Rod End design. Kamatics spherical bearings incorporate a unique "cathedral cavity" to securely capture the liner within the outer race in addition to the adhesive bond to provide a integral KArOn dual retention system. The KArOn liner is installed while in a liquid state and completely fills the pre-determined cavity between the ball and outer race. Ball / liner conformity is perfect.

Review the Kamatics KArOn Design Guide and "Journal Bearings" section of this catalog for items to consider when employing a self-lubricating journal bearing. Things to consider include the capability to machine the bore after installation and varying the liner thickness to suit your application.

See the Kamatics KArOn Design Guide or Table 2 of this catalog for liner choices and a description of the liners available. KArOn V is recommended for general high load bearing applications. For those applications where operating temperatures exceed +250° F (+120° C) KArOn B is recommended. Select KArOn F or VS as required for special bearing operating requirements. Contact Kamatics engineering for assistance in selecting the liner system for your application.

TABLE OF CONTENTS			
			PAGE
SPHERICAL BEARINGS			
	KNR-CN	NARROW SERIES	7
	KNR-CW	WIDE SERIES	9
	KNR-CE	HIGH MISALIGNMENT SERIES	11
	KNR-CS	SPECIAL SIZE SERIES	13
	KNR-CT	THRUST LOADED SERIES	15
ROD END BEARINGS			
	KNRM	MALE SERIES	17
	KNRF	FEMALE SERIES	19
	KNRMH	HEAVY DUTY MALE SERIES	21
	KNRME	HIGH MISALIGNMENT MALE SERIES	23
	KNRFE	HIGH MISALIGNMENT FEMALE SERIES	25
JOURNAL BEARINGS			
	KNRJ	STRAIGHT SERIES	27
	KNRJ-UD	FLANGED SERIES	29
JOURNAL BEARINGS, COMPOSITE BACKED (MIL-B-85560)			
	KRCJ	STRAIGHT SERIES	31
	KRCJ-UD	FLANGED SERIES	33

Kamatics Sales Offices

***Please Contact Kamatics for Your Local Representative
Worldwide***

Bloomfield, CT USA

860-243-9704

fax 860-243-7993

<http://www.kamatics.com/>



Spherical Bearings

Kamatics Corporation has designed and manufactured self-lubricated spherical bearings since 1966. The original Kamatics spherical bearing was made from compacted carbon matrix liners operating against a chrome oxide coated and polished surface. This was known as a “KAcarb” bearing and is still in use today for applications operating at temperatures up to 1200°F degrees F (635°C). Since the early 1970’s Kamatics has manufactured spherical bearings with KArOn self-lube liners for temperatures to 400°F (204°C) and KAtherm for temperatures to 600°F (315°C). Contact your Kamatics representative for further information for KAtherm and KAcarb applications.

Spherical Bearing Design:

The design criterion for a KArOn lined spherical bearing is similar to the criteria for a journal bearing. The major difference is that the inner race is supplied within the bearing assembly and its hardness, surface finish and corrosion resistance is normally left up to the bearing manufacturer.

Equation 1 provides a method for calculating bearing pressures for spherical bearings and is similar to the journal bearing “projected area” approach.

Important Note: Kamatics KArOn lined spherical bearings incorporate a unique “cathedral” shaped cavity between the ball OD and outer race ID. This feature “locks” the liner within the bearing overcoming the familiar problem of liner loss suffered with many fabric lined bearings. **Figure 1** shows the “cathedral” feature.

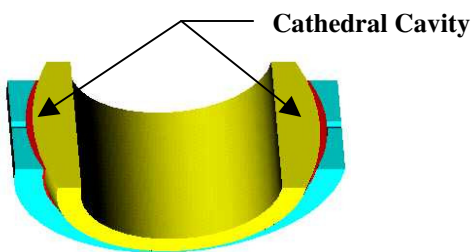

Some other important design considerations relative to the design of spherical bearings follow:

- It is imperative that the spherical surface of the ball be as hard, smooth and corrosion resistant as possible.
- There should be sufficient clamp-up torque applied to the ball faces to insure that motion takes place between the ball OD and outer race liner unless movement within the bore is anticipated.

- For applications where it is difficult to generate enough preload on the ball faces to prevent rotation between the bore and bolt/shaft, Kamatics can supply the bearing with a KArOn liner in the bore and side faces. This will eliminate damage to mating surfaces in the event that motion takes place in the bore.
- Consideration should be given to the type of installation fit between the bearing OD and housing. A press fit will reduce the operating clearance between the ball and outer race and increase the breakout torque if there is initial torque. Either condition may be acceptable for the application. The designer is cautioned to consider the consequences of the fit.
- Similar consideration should be given to the fit between the ball bore and bolt as noted above. A designer is cautioned not to use an interference fit between the ball and bolt if the ball is hardened 440C stainless steel or other materials that may be prone to stress cracking when under tensile loads.
- For those applications where the user intends to use a thermal fit technique (shrink fit) to install a KArOn spherical bearing, a solution of dry ice and solvent in which to immerse the bearing is recommended.
- To assist in housing size selection, **Tables 5 and 6 of the KArOn Design Guide** offer typical housing dimensions for use with KArOn lined spherical bearings.

Equation 1; Spherical bearing pressure;
 $S = P/A$, where;

- S = Pressure (projected area)
- P = Applied load (force)
- $A = D_{(ball)} \times H_{EFF}$
- $D_{(ball)}$ = Nominal ball OD
- H = Nominal width of the outer race
- $H_{EFF} = H$ minus “edge effects”

The “edge effects” are the possible non-load supporting liner setback allowances at each side face of the outer race. In the case of KArOn lined spherical bearings, assume the setback at each side to be 0.025 inches (0.63mm) or 0.050 inches (1.27mm) total “edge effect”.

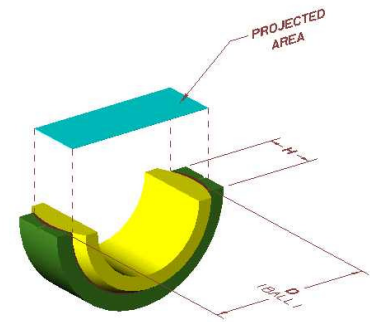

Figure 2,
(Spherical Bearing Projected Area)

Rod End Bearing Design:

Kamatics has over 35 years of experience manufacturing rod end assemblies. Materials range from carbon steel to high nickel alloys. Bore sizes range from 0.060 inch (1.5mm) to 3.00 inches (75mm) and larger. They are used in applications from farm equipment to space shuttles. Kamatics rod ends operate at temperatures ranging from cryogenic to 1000°F (538°F) with KArOn, KAtherm, and KAcarb liner systems. This catalog offers some of the more standard sizes of rod ends available. Special sizes are produced upon request. **Figure 3** shows a typical male threaded rod end assembly.

The design of a rod end assembly requires a thorough understanding of the loads it will be subjected to. For example, if the loads are predominately compression (in the direction of the threads or shank), the banjo diameter (the hoop of metal around the bearing insert) can be thinner than if the rod end were used in tension. A tension load on the rod end body causes the hole in the body containing the bearing insert to become elongated (ovalized). This elongation does not happen if the load is in compression (in the direction of the shank/threads) as the hole is not “stretched” in this direction.

The elongation creates a “pinching” force on the bearing insert in the 3-9 o’clock position relative to the shank. This can have two significant effects on the assembly. First, it tends to increase the torque required to rotate the ball. If the magnitude of the torque increase is high enough, coupled with the normal operating torque, frequent oscillation or rotation of the ball may produce unanticipated bending stresses on the rod end body and possibly lead to a fatigue failure at the banjo/shank intersection.

The second effect is relative micro motion between the housing ID and bearing OD at the 3-9 o'clock position as a consequence of the hole elongation. Frequent load reversals between tension and compression can lead to fretting between the bearing and rod end body...and eventual metal fatigue of the rod end. Classic rod end failures occur approximately 15-20 degrees below the 3-9 o'clock position.

A light interference fit between the bearing and rod end body is recommended to minimize the possibility of fretting. Kamatics manufactures spherical bearings to be installed in the rod end body with internal clearance designed to accommodate an interference fit without adding additional ball rotational torque.

The rod end body should be completely analyzed to insure that; the shank/thread size is large enough to support the loads; the banjo diameter is thick enough to react applied forces and minimize hole elongation; the fillet radius between the banjo and shank/threads is of sufficient size and with as good a surface finish as possible to minimize stress concentrations.

Kamatics is available to assist in the design of your rod end application.



Figure 3 (male rod end assembly)

Journal Bearings

Kamatics Corporation has been designing and manufacturing self-lubricating journal bearings for over 30 years. The original self-lube bearing was manufactured from compact carbon sleeves shrunk-fit into metallic housings. Operating capability of this combination exceeded 1000°F (538°C) and is still in use. They are offered as “KAcarb” bearings. Technological advancements have extended Kamatics products into a larger family of self-lube

liner systems, all exhibiting low friction, low rates of wear, and temperatures ranging from cryogenic to over 1000°F (538°C).

The majority of journal bearings (flanged or non-flanged) are manufactured with a metallic backing. The backing can be just about any metal but it is predominately stainless steel and aluminum. However, most composite structures require that the bearing be compatible with the structure. Kamatics Corporation manufactures a large size range of KArOn lined bearings with composite backings. Carbon/epoxy and fiberglass/epoxy are the most common composite combinations used.



Composite Bearings

Kamatics has “state-of-the-art” computer controlled filament winding and braiding capabilities. Composite backed bearings in excess of 40 inches (1 meter) have been produced. Kamatics KArOn lined/composite backed bearings are qualified to MIL-B-85560. Composite bearings for operation at temperatures to 600°F (315°C) are possible with our KAtherm technology.

Kamatics fiberglass/epoxy backed MIL-B-85560 bushings are ideally suited for use in marine applications. KArOn self-lubricating lined and fiberglass/epoxy backed bearings have been in use in hydroelectric submersed applications for over 15 years. Kamatics KArOn and fiberglass/epoxy backed bearings also offer superior protection against galvanic corrosion since the bearing does not contain any metallic materials.

Kamatics also produces bearings made from solid KArOn...without any backing for those applications where space is limited. Solid KArOn bearings are normally pressed in, or bonded to, a housing and when installed have similar load and performance capabilities of metal or composite backed KArOn bearings.

A suggested approach to the design of both flanged and non-flanged KArOn self-lubricating journal bearings is offered below.

The bearing pressure distribution used in the following equations is in a simplified form.

Forgoing extensive discussion on actual pressure distribution and for calculation purposes, assume the area supporting the load to be a “projected area” pressure as defined in **Equation 2**.

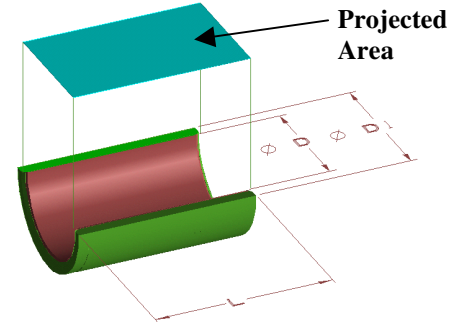

Figure 4, (Non-flanged Journal)

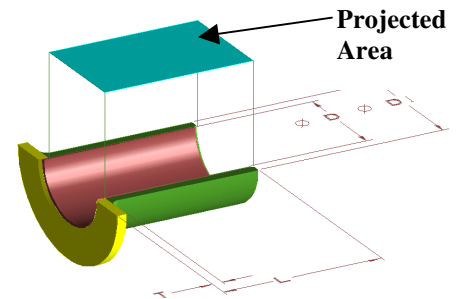

Figure 4, (Flanged Journal)

Equation 2; Journal bearing pressure; $S=P/A$, where;

- S = Pressure (projected area)
- P = Applied load (force)
- $A = D \times L_{EFF}$
- D = Nominal journal ID
- L = Nominal length of the journal (including the flange if there is one)
- $L_{EFF} = L$ minus “edge effects”

The “edge effects” are the non-load supporting chamfers and the area under the flange, in the case of flanged journals. The “Projected Area” concept defined is widely used in the bearing industry and most published load ratings are based on this concept.

Sizing of the journal bore is based upon a combination of load, shear and tensile allowables of the bolt/pin material plus any bending under load. The bearing stress on the bearing should be checked once the bolt/pin diameter has been established.

It is important to be as accurate as possible when determining forces and both normal operating and maximum forces are required. For instance, supplying and calculating size based only on the maximum force coupled with an operation or flight spectrum may cause the bearing to be larger than necessary

or the amount of calculated wear to be unrealistically high. (Obviously, the bolt/pin has to be selected based on maximum loading among other things.) If the operating time at maximum load is relatively low and cycles are few, it may be overlooked for the initial sizing. This is assuming the loads are within the liner materials capability (below static limit load value). Once initially sized, the amount of wear attributed to the operating extremes can be added to the amount of wear attributed to the normal operating conditions. All movement under load has some contribution to the total wear.

The length of the journal bearing should be kept to a length-to-diameter (L/D) ratio of less than 1.5 to keep both pin bending and edge loading to a minimum. Edge loading can lead to more than anticipated wear. Larger L/D ratios can be designed but only after careful consideration to pin bending is given. Bell-mouths (shallow tapers) machined into the bore will minimize edge loading due to large L/D ratios.

Things to consider in the design of a KAron lined self-lube journal bearing:

- **KAron liner material is machinable** using conventional turning, reaming or honing procedures. Appendix A of the Kamatics KAron Design guide explains these techniques. Bearings can be supplied with thicker liner material to allow for final machining of the ID after installation.
- Consideration should be given to the type of installation fit between the bearing OD and housing. A press fit will reduce the operating clearance between the bore and mating shaft, and if not addressed, may create an interference with the shaft. Tables 2 & 3 of the KAron Design Guide offer housing dimensions for use with KAron journal bearings.
- As in the case of many journal bearing applications, the bearing manufacturer supplies only one half of the bearing system. The end user supplies the other half of the bearing system in the form of a bolt, sleeve, pin or similar.
- As noted, the user supplies the mating part and the installation of this mating part must be carefully controlled. The shaft must be accurately aligned to minimize liner damage during insertion into the bearing. It should have a smooth chamfer or radius on the end that enters the bearing. Fortunately, Kamatics self-lube liners have a significant advantage over fabric self-lube bearings in that in the event of localized damage during shaft installation, the damage remains local. There are no interconnecting fibers or

weave that will allow the damage to progress and propagate under load until loss of liner or jamming of the shaft has occurred in the bore.

- It is important to select the most corrosion resistant and hardest material with the smoothest surface finish possible *for the application under consideration*. Consider the use of hard chrome plate to further enhance the shaft finish and hardness.
- The selection of mating materials can be a difficult decision and in order not to “over-design”, the amount of wear and the type and number of expected operating cycles should be known.

Table 1 lists the potential trade-off relative to life with various mating shaft hardness and surface finishes. Table 1 displays general “trend” type of information and should not be taken as an absolute value. Kamatics engineering is available for guidance if necessary.

TABLE 1	
Mating Bearing Surface	
Surface Finish	
Roughness - $\mu\text{in.}$	Life Factor
4-10 (.025-.25 μm)	1.00
16 (0.4 μm)	0.75
32 (0.8 μm)	0.40
Surface Hardness	
Hardness Rc	Life Factor
50+	1.00
40	0.60
30	0.40

Radial Dynamic Load

The radial dynamic load capacities noted in this catalog are based on specification SAE AS81820. These requirements are configured for approximately .0045 inches (0.11 mm) of maximum liner wear after 25000 cycles of inner ring oscillating at $\pm 25^\circ$ (50° included angle) and at 10 cpm. The “-4” sizes are slightly less, .0037 (0.094mm) inches for the narrow series and .0039 inches (0.10mm) for the wide series.

Radial Static Limit Load

The radial static limit load rating is the maximum radial load that will result in a permanent set in the bearing no greater than .003 inches (0.076mm) after the load is applied for three minutes.

Axial Static Limit Load Rating

The axial static limit load rating is the maximum axial (thrust) load that will result in a permanent set in the bearing no

greater than .005 inches (0.127mm) after the load is applied for three minutes.

Ultimate Static Load Rating

The ultimate radial and axial load rating equals 1.5 times the radial and axial static limit loads listed. At loads equal to this magnitude, no race or ball fracture shall occur, nor will the ball become dislodged from the race.

Fatigue Load (Rod Ends)

The fatigue load capacity listed for the rod ends in this catalog are based on the requirements of SAE AS81935. The ratings listed will endure a minimum of 50,000 load reversals.

Corrosion Resistance

The Kamatics Marine Bearings Catalog offers a range of metallic material choices for varying degrees of corrosion protection for applications that span within-the-hull to submersed outside-the-hull applications and span from fresh water to seawater applications

Kamatics Marine Bearings offer material selections such as Inconel, Monel, Titanium and fiberglass/epoxy to provide for the highest degree of corrosion resistance for demanding maritime applications.

TABLE 2
Karon Liner Selection Chart

Liner	Approximate Physical Properties	Characteristics	Typical Applications
KAron V High Load / Low Friction	Density – 1.36 gm/cc Hardness Rockwell M85 Thickness Range .005 - .060” (.127 – 1.5 mm)	Dynamic operating Pressures to 40,000 psi (276 mPa). Velocities to 10 fpm (3 M/min.) Temp Range –100° to 300° F (-73° to 150°C) Mil-B-8943 Qualified	Track rollers. Cam followers. Marine/naval applications. Aircraft shock struts. Other high loaded, low friction applications.
KAron B High Load	Density – 1.51 gm/cc Hardness Rockwell M95 Thickness Range .005 - .060” (.127 – 1.5 mm)	Dynamic operating Pressures to 50,000 psi (345 mPa). Velocities to 3 fpm (1 M/min.) Temp Range –100° to 400° F (-73° to 205°C) SAE AS81820 & SAE AS81934 Qualified	Aircraft controls, landing gears etc. Highly loaded linkages. Jet engine controls. Other high loaded demanding, maintenance free applications.
KAron F Low Friction	Density – 1.36 gm/cc Hardness Rockwell M85 Thickness Range .003” – min. (.076 mm min.)	Rubbing surface is a predominately PTFE enriched outer surface, providing low coefficient of friction at low loads and at low temperatures. The general operating parameters are the same as KAron V. A minimum thickness liner of .003” (.076 mm) can be obtained.	Spherical bearings Track rollers. Cam followers Other moderately high loaded, low friction applications
KAron VS Low Friction	Density – 1.56 gm/cc Hardness Rockwell 15X 88 Thickness Range .005 - .060” (.127 – 1.5 mm)	Dynamic operating pressures up to 15,000 psi (103mPa), excellent low temperature friction capabilities. Temp Range –100° to 300° F (-73° to 150°C)	Spherical bearings Track rollers. Cam followers Other moderate loaded, low friction applications

KARON Lined Spherical Bearings

KNR-CN SERIES – NARROW

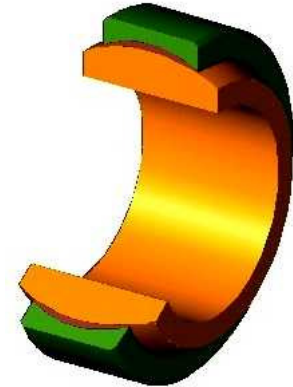
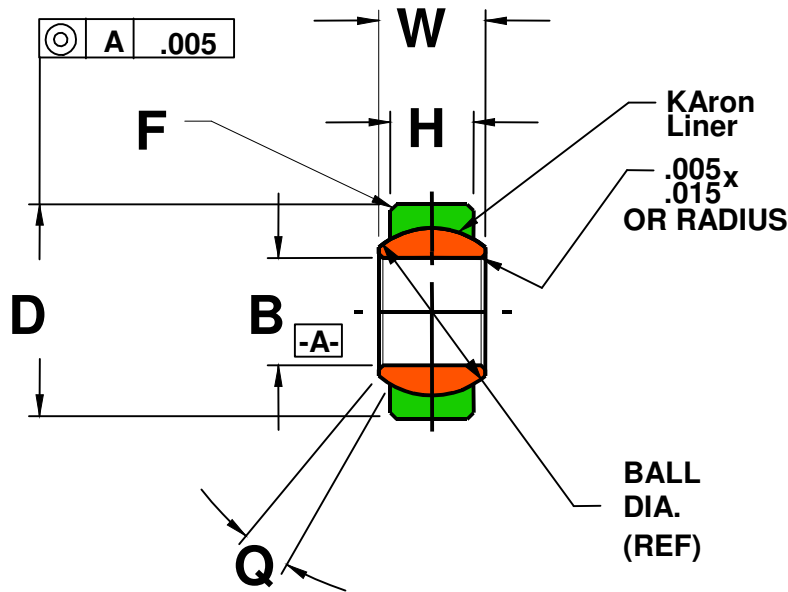

BEARING PART NUMBER	B	D	W	H	Q°	F	LOAD RATINGS ARE CALCULATED FOR Karon "V"			BALL DIA. (REF.)
	BORE DIA. +.0000 -.0005	OUTSIDE DIA. +.0000 -.0005	BALL WIDTH +.000 -.005	RACE WIDTH +.010 -.000	MIS-ALIGNMENT ANGLE	MIN. CHAM. 45°	RADIAL LIMIT STATIC LOAD (LBS.)	RADIAL ULTIMATE STATIC LOAD (LBS.)	RADIAL DYNAMIC LOAD RATING (LBS.)	
KNR3-CN	0.1900	0.5625	0.281	0.213	10°	0.020	3922	5883	1783	0.437
KNR4-CN	0.2500	0.6562	0.343	0.245	10°		5363	8044	2438	0.500
KNR5-CN	0.3125	0.7500	0.375	0.276	10°		7380	11070	3355	0.593
KNR6-CN	0.3750	0.8125	0.406	0.307	9°		8834	13252	4016	0.625
KNR7-CN	0.4375	0.9062	0.437	0.338	8°		11385	17078	5175	0.718
KNR8-CN	0.5000	1.0000	0.500	0.385	8°	0.030	13234	19851	6015	0.781
KNR9-CN	0.5625	1.0937	0.562	0.432	8°		18384	27576	8356	0.875
KNR10-CN	0.6250	1.1875	0.625	0.495	8°		24475	36713	11125	1.000
KNR12-CN	0.7500	1.4375	0.750	0.588	8°		36988	55481	16813	1.250
KNR14-CN	0.8750	1.5625	0.875	0.698	8°		49005	73508	22275	1.375
KNR16-CN	1.0000	1.7500	1.000	0.792	9°		63766	95648	28984	1.562
KNR18-CN	1.1250	2.1250	1.125	0.906	8°		82390	123585	37450	1.750
KNR20-CN	1.2500	2.3125	1.250	1.000	6°		101234	151852	46016	1.937
KNR22-CN	1.3750	2.5625	1.375	1.100	8°		136383	204574	61992	2.156
KNR24-CN	1.5000	2.8125	1.500	1.200	8°	148242	222363	67383	2.344	

HOUSING BORE FITS = OUTSIDE DIA. +.0000 -.0005

KARON Lined Spherical Bearings

KNR-CN SERIES - NARROW

Part Number Example:

KNR 8 - C N G V - 3 C 6

- KNR - KArOn Marine self-lubricating bearing
- 8 - Size of bore in 1/16" increments
- C - Spherical Bearing
- N - Narrow Series
- G - Add G for Grooved Outer Race
- V - Karon Liner Type*
- 3 - Ball Material Code (see chart below)
- C - Plating Code (see chart below)
- 6 - Outer Race Material Code (see chart below)

Ball/Race Material Code	Ball/Race Material	Ball Hardness	Race Hardness
1	PH13-8MO Stainless per AMS 5629	Rc 43 min.	N/A
2	17-4PH Stainless per AMS 5643	Rc 40-47	Rc 28-37
3	Inconel 718 per AMS 5663 or AMS 5662	*	*
4	Titanium 6AL4V per AMS 4928	*	*
5	316 Stainless per QQ-S-763 or AMS 5653	*	*
6	Inconel 625 per AMS 5666	*	*
7	Monel K-500 per QQ-N-286	*	*
8	Monel 400 per QQ-N-281	*	*
	Other materials are available. Please contact Kamatics for the proper part number.	*Ball and Race equivalent hardness per specification.	

Plating Code	Ball Plating Material (Ball OD, Side Faces Optional)
A	Chromium per SAE AMS-QQ-C-320
B	Karamite (Ceramic)
C	Nickel per SAE AMS-QQ-N-290
Outer Race Plating (Outer Race, OD)	
D	Cadmium per SAE AMS-QQ-P-416
	Other platings are available. Please contact Kamatics for the proper part number.

*See Table 2 for liner options

KARON Lined Spherical Bearings

KNR-CW SERIES - WIDE

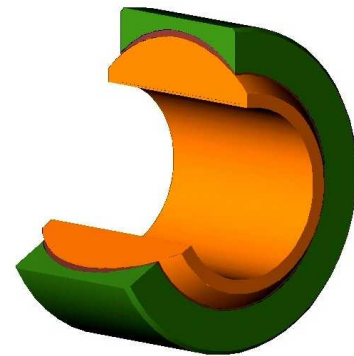
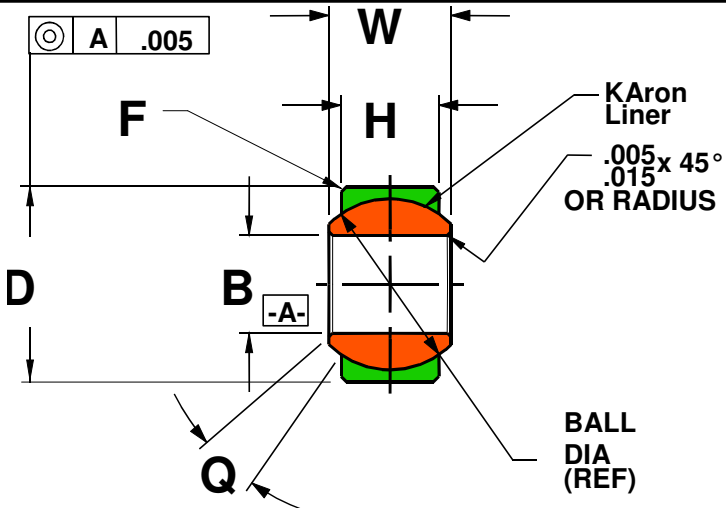

BEARING PART NUMBER	B	D	W	H	Q°	F	LOAD RATINGS ARE CALCULATED FOR KARON "V"			
	BORE DIA. +.0000 -.0005	OUTSIDE DIA. +.0000 -.0005	BALL WIDTH +.000 -.005	RACE WIDTH +.010 -.000	APPROX. MIS-ALIGNMENT ANGLE	MIN. CHAM. 45°	RADIAL LIMIT STATIC LOAD (LBS.)	RADIAL ULTIMATE STATIC LOAD (LBS.)	RADIAL DYNAMIC LOAD RATING (LBS.)	BALL DIA. (REF.)
KNR3-CW	0.1900	0.6250	0.437	0.322	15°	0.020	7948	11921	3613	0.531
KNR4-CW	0.2500	0.6250	0.437	0.322	15°		7948	11921	3613	0.531
KNR5-CW	0.3125	0.6875	0.437	0.312	14°		8556	12834	3889	0.593
KNR6-CW	0.3750	0.8125	0.500	0.401	8°		13272	19908	6033	0.687
KNR7-CW	0.4375	0.9375	0.562	0.437	10°		16629	24943	7559	0.781
KNR8-CW	0.5000	1.0000	0.625	0.500	9°		21656	32484	9844	0.875
KNR9-CW	0.5625	1.1250	0.687	0.531	10°		26455	39683	12025	1.000
KNR10-CW	0.6250	1.1875	0.750	0.562	12°		29920	44880	13600	1.062
KNR12-CW	0.7500	1.3750	0.875	0.625	13°		39531	59297	17969	1.250
KNR14-CW	0.8750	1.6250	0.875	0.750	6°		52938	79406	24063	1.375
KNR16-CW	1.0000	2.1250	1.375	1.000	12°		97969	146953	44531	1.875
KNR20-CW	1.2500	2.3750	1.500	1.125	14°		123793	185689	56270	2.093
KNR22-CW	1.3750	2.5625	1.687	1.218	14°		146548	219821	66613	2.281
KNR24-CW	1.5000	2.6875	1.687	1.218	13°	0.030	153534	230300	69788	2.390
KNR26-CW	1.6250	2.8750	1.750	1.281	12°		171378	257067	77899	2.531
KNR28-CW	1.7500*	3.0000*	1.812	1.312	12°		185455	278182	84298	2.672
KNR30-CW	1.8750*	3.1250*	1.875	1.343	12°		200011	300016	90914	2.812
KNR32-CW	2.0000*	3.2500*	1.937	1.375	13°		214070	321105	97305	2.937
KNR36-CW	2.2500*	3.6250*	2.000	1.406	12°		235393	353090	106997	3.156
KNR40-CW	2.5000*	3.9375*	2.062	1.437	11°		262230	393345	119195	3.437
KNR44-CW	2.7500*	4.1250*	2.187	1.500	12°		294078	441117	133672	3.687
KNR48-CW	3.0000*	4.3750*	2.312	1.562	12°	327443	491164	148838	3.937	

HOUSING BORE FITS = OUTSIDE DIA. + TOLERANCE

BEARING P/N	TOLERANCE
3 - 26	+.0000 - .0005
28-48	+.0000 - .0008

*+.0000
-.0008

KARON Lined Spherical Bearings

KNR-CW SERIES - WIDE

Part Number Example:

KNR 8 - C W G V - 3 C 6

- KNR - KArOn Marine self-lubricating bearing
- 8 - Size of bore in 1/16" increments
- C - Spherical Bearing
- W - Wide Series
- G - Add G for Grooved Outer Race
- V - Karon Liner Type*
- 3 - Ball Material Code (see chart below)
- C - Plating Code (see chart below)
- 6 - Outer Race Material Code (see chart below)

Ball/Race Material Code	Ball/Race Material	Ball Hardness	Race Hardness
1	PH13-8MO Stainless per AMS 5629	Rc 43 min.	N/A
2	17-4PH Stainless per AMS 5643	Rc 40-47	Rc 28-37
3	Inconel 718 per AMS 5663 or AMS 5662	*	*
4	Titanium 6AL4V per AMS 4928	*	*
5	316 Stainless per QQ-S-763 or AMS 5653	*	*
6	Inconel 625 per AMS 5666	*	*
7	Monel K-500 per QQ-N-286	*	*
8	Monel 400 per QQ-N-281	*	*
	Other materials are available. Please contact Kamatics for the proper part number.	*Ball and Race equivalent hardness per specification.	

Plating Code	Ball Plating Material (Ball OD, Side Faces Optional)
A	Chromium per SAE AMS-QQ-C-320
B	Karamite (Ceramic)
C	Nickel per SAE AMS-QQ-N-290
Outer Race Plating (Outer Race, OD)	
D	Cadmium per SAE AMS-QQ-P-416
	Other platings are available. Please contact Kamatics for the proper part number.

*See Table 2 for liner options

KARON Lined Spherical Bearings

KNR-CE SERIES - HIGH MISALIGNMENT

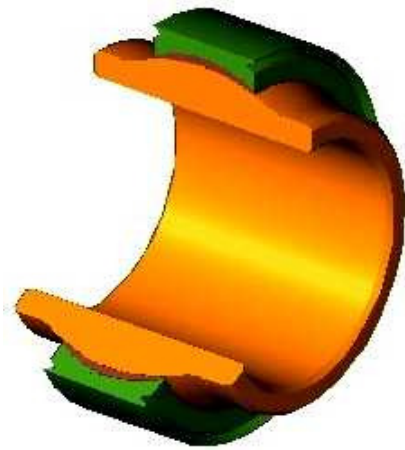
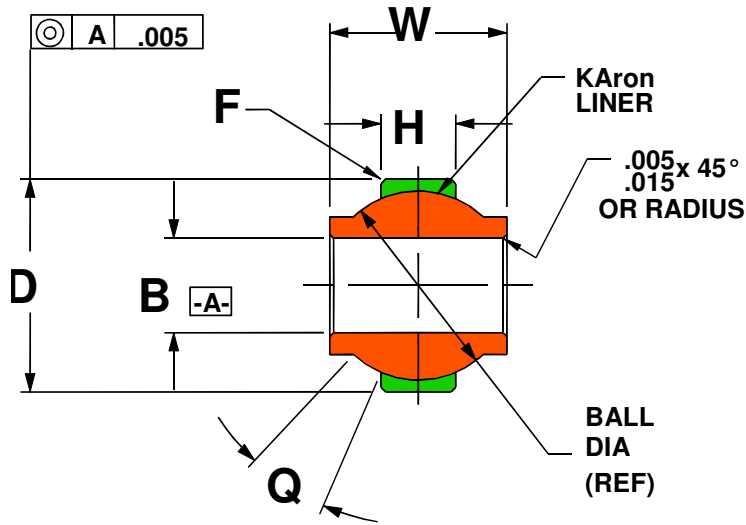

BEARING PART NUMBER	B	D	W	H	Q°	F	LOAD RATINGS ARE CALCULATED FOR KARON "V"			
	BORE DIA. +.0000 -.0005	OUTSIDE DIA. +.0000 -.0005	BALL WIDTH +.000 -.005	RACE WIDTH +.005 -.005	MIS-ALIGNMENT ANGLE	MIN. CHAM. 45°	RADIAL LIMIT STATIC LOAD (LBS.)	RADIAL ULTIMATE STATIC LOAD (LBS.)	RADIAL DYNAMIC LOAD RATING (LBS.)	BALL DIA. (REF.)
KNR3-CE	0.1900	0.6250	0.560	.250	20°	0.020	7948	11921	3613	0.531
KNR4-CE	0.2500	0.7400	0.593	0.250	24°		6531	9797	2969	0.593
KNR5-CE	0.3125	0.6875	0.625	.322	23°		12461	18691	5664	0.593
KNR6-CE	0.3750	0.9060	0.813	0.340	23°		12461	18691	5664	0.781
KNR7-CE	0.4375	1.0000	0.875	0.340	23°		13956	20934	6344	0.875
KNR8-CE	0.5000	1.1250	0.937	0.396	24°		19030	28545	8650	1.000
KNR9-CE	0.5625	1.2500	1.000	0.437	24°		23946	35918	10884	1.125
KNR10-CE	0.6250	1.3750	1.200	0.562	17°30'		35200	52800	16000	1.250
KNR12-CE	0.7500	1.5625	1.280	0.615	18°		42728	64092	19422	1.375
KNR14-CE	0.8750	1.7500	1.400	0.620	18°		48005	72007	21820	1.531
KNR16-CE	1.0000	2.1250	1.875	0.830	21°		80438	120656	36563	1.875
KNR20-CE	1.2500	2.5000	1.875	1.000	21°		117563	176344	53438	2.250
KNR24-CE	1.5000	3.0000	2.250	1.170	21°	0.030	164588	246881	74813	2.672
KNR26-CE	1.6250	3.1250	2.437	1.187	24°		175880	263820	79945	2.812
KNR28-CE	1.7500	3.5625	2.875	1.250	30°		214500	321750	97500	3.250

HOUSING BORE FITS = OUTSIDE DIA. +.0000 -.0005

KARON Lined Spherical Bearings

KNR-CE SERIES - HIGH MISALIGNMENT

Part Number Example:

KNR 8 - C E G V - 3 C 6

- KNR - KAron Marine self-lubricating bearing
- 8 - Size of bore in 1/16" increments
- C - Spherical Bearing
- E - High Misalignment Series
- G - Add G for Grooved Outer Race
- V - Karon Liner Type*
- 3 - Ball Material Code (see chart below)
- C - Plating Code (see chart below)
- 6 - Outer Race Material Code (see chart below)

Ball/Race Material Code	Ball/Race Material	Ball Hardness	Race Hardness
1	PH13-8MO Stainless per AMS 5629	Rc 43 min.	N/A
2	17-4PH Stainless per AMS 5643	Rc 40-47	Rc 28-37
3	Inconel 718 per AMS 5663 or AMS 5662	*	*
4	Titanium 6AL4V per AMS 4928	*	*
5	316 Stainless per QQ-S-763 or AMS 5653	*	*
6	Inconel 625 per AMS 5666	*	*
7	Monel K-500 per QQ-N-286	*	*
8	Monel 400 per QQ-N-281	*	*
	Other materials are available. Please contact Kamatics for the proper part number.	*Ball and Race equivalent hardness per specification.	

Plating Code	Ball Plating Material (Ball OD, Side Faces Optional)
A	Chromium per SAE AMS-QQ-C-320
B	Karamite (Ceramic)
C	Nickel per SAE AMS-QQ-N-290
Outer Race Plating (Outer Race OD)	
D	Cadmium per SAE AMS-QQ-P-416
	Other platings are available. Please contact Kamatics for the proper part number.

*See Table 2 for liner options

KARON Lined Spherical Bearings

KNR-CS SERIES – SPECIAL SIZE

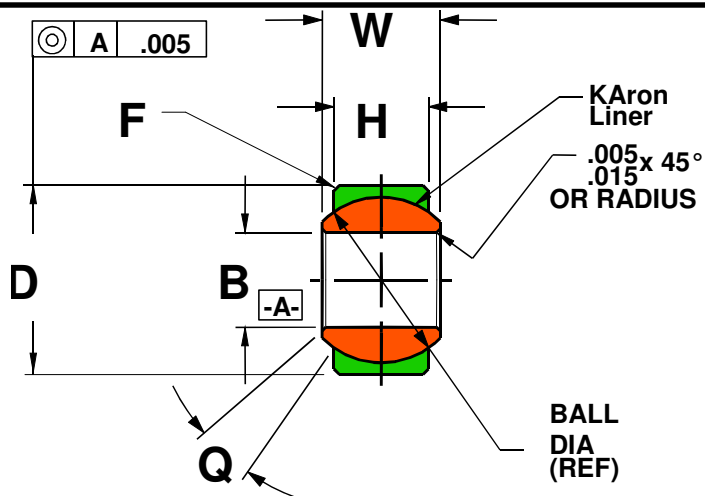

BEARING PART NUMBER	B	D	W	H	Q°	F	LOAD RATINGS ARE CALCULATED FOR KARON "V"			
	BORE DIA. +.0000 -.0005	OUTSIDE DIA. +.0000 -.0005	BALL WIDTH +.000 -.005	RACE WIDTH +.010 -.000	MIS-ALIGNMENT ANGLE	MIN. CHAM. 45°	RADIAL LIMIT STATIC LOAD (LBS.)	RADIAL ULTIMATE STATIC LOAD (LBS.)	RADIAL DYNAMIC LOAD RATING (LBS.)	BALL DIA. (REF.)
KNR16-CS	1.0000	1.6250	0.875	0.750	5°	0.020	55344	83016	25156	1.437
KNR20-CS	1.2500	2.0000	1.093	0.937			86947	130421	39521	1.781
KNR24-CS	1.5000	2.4375	1.312	1.125			127488	191232	57949	2.156
KNR28-CS	1.7500	2.8125	1.531	1.312			174679	262018	79399	2.515
KNR30-CS	1.8750	3.1250*	1.625	1.343	6°	0.030	200127	300190	90967	2.812
KNR32-CS	2.0000	3.1875*	1.750	1.500	5°		229281	343922	104219	2.875
KNR36-CS	2.2500	3.5625*	1.969	1.678	6°		282611	423916	128459	3.156
KNR40-CS	2.5000	3.9375*	2.187	1.875	5°		351313	526969	159688	3.500
KNR44-CS	2.7500	4.3750*	2.406	2.062			428914	643371	194961	3.875
KNR48-CS	3.0000	4.7500*	2.625	2.250			514250	771375	233750	4.250
KNR52-CS	3.2500*	5.1250**	2.844	2.437			0.032	613886	920829	279039
KNR56-CS	3.5000*	5.5000**	3.062	2.625	713790			1070685	324450	5.040
KNR60-CS	3.7500*	5.8750**	3.281	2.812	818943			1228415	372247	5.390
KNR64-CS	4.0000*	6.2500**	3.500	3.000	932938			1399406	424063	5.750
KNR68-CS	4.2500*	6.6250**	3.719	3.187	5°	0.044	1056945	1585418	480430	6.125
KNR72-CS	4.5000*	7.0000**	3.937	3.375			1184116	1776173	538234	6.475
KNR76-CS	4.7500*	7.3750**	4.156	3.562			1318505	1977757	599320	6.825
KNR80-CS	5.0000*	7.7500**	4.375	3.750			1463165	2194748	665075	7.190
KNR88-CS	5.5000*	8.6250**	4.938	4.125	6°	0.125	1803086	2704628	819584	8.045
KNR96-CS	6.0000*	9.5000**	5.438	4.500	7°		2175828	3263741	989013	8.890

*+.0000
-.0008
**+.0000
-.0010

HOUSING BORE FITS = OUTSIDE DIA. + TOLERANCE	
BEARING P/N	TOLERANCE
16 - 28	+.0000 -.0005
30 - 48	+.0000 -.0008
52 - 96	+.0000 -.0010

KARON Lined Spherical Bearings

KNR-CS SERIES – SPECIAL SIZE

Part Number Example:

KNR 8 – C S G V – 3 C 6

- KNR - KArOn Marine self-lubricating bearing
- 8 - Size of bore in 1/16” increments
- C - Spherical Bearing
- S - Special Size Series
- G - Add G for Grooved Outer Race
- V - Karon Liner Type*
- 3 - Ball Material Code (see chart below)
- C - Plating Code (see chart below)
- 6 - Outer Race Material Code (see chart below)

Ball/Race Material Code	Ball/Race Material	Ball Hardness	Race Hardness
1	PH13-8MO Stainless per AMS 5629	Rc 43 min.	N/A
2	17-4PH Stainless per AMS 5643	Rc 40-47	Rc 28-37
3	Inconel 718 per AMS 5663 or AMS 5662	*	*
4	Titanium 6AL4V per AMS 4928	*	*
5	316 Stainless per QQ-S-763 or AMS 5653	*	*
6	Inconel 625 per AMS 5666	*	*
7	Monel K-500 per QQ-N-286	*	*
8	Monel 400 per QQ-N-281	*	*
	Other materials are available. Please contact Kamatics for the proper part number.	*Ball and Race equivalent hardness per specification.	

Plating Code	Ball Plating Material (Ball OD, Side Faces Optional)
A	Chromium per SAE AMS-QQ-C-320
B	Karamite (Ceramic)
C	Nickel per SAE AMS-QQ-N-290
Outer Race Plating (Outer Race, OD)	
D	Cadmium per SAE AMS-QQ-P-416
	Other platings are available. Please contact Kamatics for the proper part number.

KARON Lined Spherical Bearings

KNR-CT SERIES - THRUST LOADED

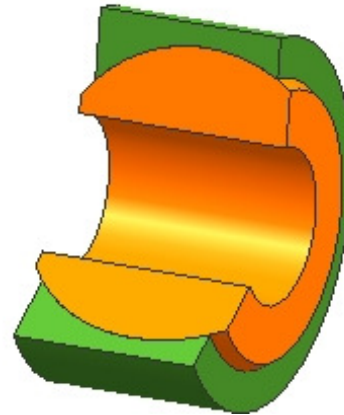
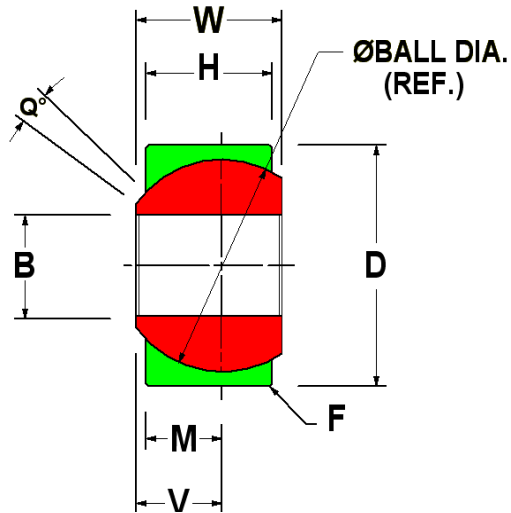

	B	D	W	H	M	V	Q°	F	CALCULATED FOR KARON "V"	
BEARING PART NUMBER	BORE DIA.	OUTSIDE DIA.	BALL WIDTH	RACE WIDTH	BALL TO RACE	BALL TO FACE	MISALIGNMENT ANGLE	MIN. CHAM. 45°	ULTIMATE STATIC THRUST LOAD (LBS.)	BALL DIA. (REF.)
	+0.0000 -0.0005	+0.0000 -0.0005	+0.000 -0.005	+0.005 -0.005	+0.005 -0.005	+0.005 -0.005				
KNR4-CT	0.2500	0.8125	0.437	0.375	0.250	0.281	3°	0.025	5890	0.687
KNR5-CT	0.3125	0.9375	0.562	0.500	0.295	0.326			8202	0.781
KNR6-CT	0.3750	1.0000	0.600	0.531	0.325	0.359			9955	0.875
KNR7-CT	0.4375	1.1250	0.656	0.578	0.375	0.414			13254	1.000
KNR8-CT	0.5000	1.1875	0.700	0.625	0.400	0.437			15080	1.062
KNR9-CT	0.5625	1.3750	0.875	0.781	0.467	0.514			20554	1.250
KNR10-CT	0.6250	1.5625	0.937	0.825	0.525	0.581	4°	25977	1.375	
KNR12-CT	0.7500	1.7500	1.000	0.895	0.578	0.630	3°	31487	1.562	
KNR14-CT	0.8750	2.1250	1.281	1.140	0.700	0.770	4°	46181	1.781	
KNR16-CT	1.0000	2.3750	1.437	1.250	0.755	0.848	5°	0.035	53724	2.093
KNR20-CT	1.2505	2.5625	1.500	1.312	0.812	0.906			62218	2.281
KNR22-CT	1.3750	2.7500	1.562	1.343	0.828	0.937			64615	2.500
KNR24-CT	1.5000	3.0000	1.625	1.375	0.843	0.968			66977	2.687
KNR26-CT	1.6250	3.1250	1.687	1.406	0.859	1.000	6°	69544	2.750	
KNR28-CT	1.7500*	3.2500*	1.750	1.437	0.875	1.031	6°	72158	2.875	
KNR30-CT	1.8750*	3.3750*	1.875	1.468	0.890	1.093	8°	74654	3.000	
KNR32-CT	2.0000*	3.5000*	1.875	1.500	0.906	1.093	7°	77405	3.125	
KNR36-CT	2.2500*	3.9062*	2.000	1.406	0.875	1.187	10°	72158	3.437	
KNR40-CT	2.5000*	4.1250*	2.062	1.437	0.937	1.250	10°	82835	3.687	
KNR44-CT	2.7500*	4.3750*	2.187	1.500	1.125	1.312	7°	119282	3.937	

* +0.0000
-0.0008

HOUSING BORE FITS = OUTSIDE DIA. + TOLERANCE	
BEARING P/N	TOLERANCE
4-28	+0.0000 -0.0005
30-44	+0.0000 -0.0008

KARON Lined Spherical Bearings

KNR-CT SERIES - THRUST LOADED

Part Number Example:

KNR 8 - C T G V - 3 C 6

- KNR - KArOn Marine self-lubricating bearing
- 8 - Size of bore in 1/16" increments
- C - Spherical Bearing
- T - Thrust Loaded Series
- G - Add G for Grooved Outer Race
- V - Karon Liner Type*
- 3 - Ball Material Code (see chart below)
- C - Plating Code (see chart below)
- 6 - Outer Race Material Code (see chart below)

Ball/Race Material Code	Ball/Race Material	Ball Hardness	Race Hardness
1	PH13-8MO Stainless per AMS 5629	Rc 43 min.	N/A
2	17-4PH Stainless per AMS 5643	Rc 40-47	Rc 28-37
3	Inconel 718 per AMS 5663 or AMS 5662	*	*
4	Titanium 6AL4V per AMS 4928	*	*
5	316 Stainless per QQ-S-763 or AMS 5653	*	*
6	Inconel 625 per AMS 5666	*	*
7	Monel K-500 per QQ-N-286	*	*
8	Monel 400 per QQ-N-281	*	*
	Other materials are available. Please contact Kamatics for the proper part number.	*Ball and Race equivalent hardness per specification.	

Plating Code	Ball Plating Material (Ball OD, Side Faces Optional)
A	Chromium per SAE AMS-QQ-C-320
B	Karamite (Ceramic)
C	Nickel per SAE AMS-QQ-N-290
Outer Race Plating (Outer Race, OD)	
D	Cadmium per SAE AMS-QQ-P-416
	Other platings are available. Please contact Kamatics for the proper part number.

*See Table 2 for liner options

KARON Lined Rod End Bearings

KNRM SERIES - MALE

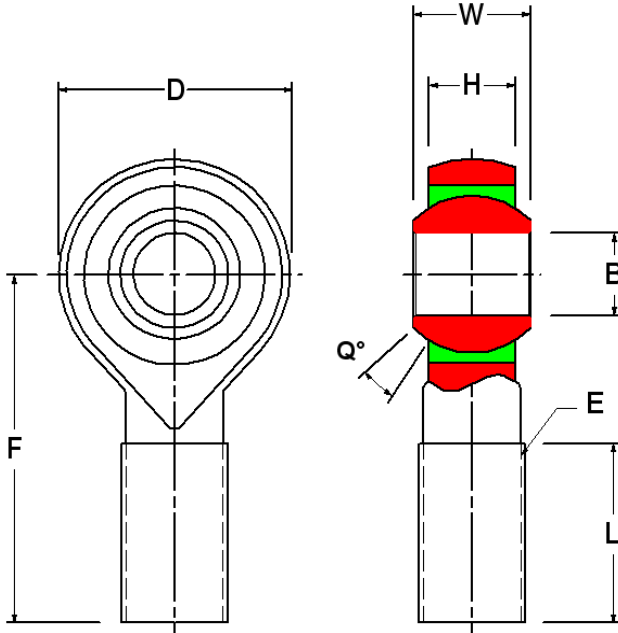

	B	D	W	H	L	F	E	Q°	Based on 170000 psi Tensile Strength
BEARING PART NUMBER	BORE DIA.	ROD END DIA.	BALL WIDTH	BODY WIDTH	THREAD LENGTH	BODY LENGTH	THREAD SIZE UNF-3A UN-3A	MIS- ALIGN- MENT ANGLE	RADIAL ULTIMATE STATIC LOAD (LBS.)
	+0.000 -0.005	+0.010 -0.010	+0.000 -0.002	+0.005 -0.005	+0.062 -0.031	+0.010 -0.010			
KNR3M	0.1900	0.781	0.437	0.337	1.000	1.562	5/16-24	14°	9961
KNR4M	0.2500	0.781	0.437	0.337	1.000	1.562	5/16-24	13°	9961
KNR5M	0.3125	0.875	0.437	0.327	1.062	1.875	5/16-24	13°	11268
KNR6M	0.3750	1.000	0.500	0.416	1.250	1.938	3/8-24	8°	15578
KNR7M	0.4375	1.125	0.562	0.452	1.375	2.125	7/16-20	8°	18888
KNR8M	0.5000	1.312	0.625	0.515	1.500	2.438	1/2-20	7°	27829
KNR10M	0.6250	1.500	0.750	0.577	1.625	2.625	5/8-18	11°	31702
KNR12M	0.7500	1.750	0.875	0.640	1.750	2.875	3/4-16	13°	39784
KNR14M	0.8750	2.000	0.875	0.765	1.875	3.375	7/8-14	5°	59658
KNR16M	1.0000	2.750	1.375	1.015	2.125	4.125	1 1/4-12	14°	112612
KNR20M	1.2500	2.875	1.500	1.140	3.125	5.000	1 1/4-12	12°	112077
KNR24M	1.5000	3.500	1.687	1.218	3.750	6.250	1 1/2-12	12°	173914
KNR28M	1.7500	3.875	1.875	1.312	4.375	7.000	1 3/4-12	12°	204962
KNR32M	2.0000	4.375	1.937	1.375	5.000	7.875	2-12	10°	257570
KNR36M	2.2500	5.000	2.000	1.406	5.625	9.000	2 1/4-12	10°	336089
KNR40M	2.5000	5.437	2.062	1.437	6.250	9.875	2 1/2-12	9°	374512
KNR44M	2.7500	5.750	2.187	1.500	6.750	10.625	2 3/4-12	9°	405470

KARON Lined Rod End Bearings

KNRM SERIES - MALE

Part Number Example:

KNR 8 M V L K - 4 A 2 2

- KNR - KArOn Marine self-lubricating bearing
- 8 - Size of bore in 1/16" increments
- M - Male Thread Rod End Bearing
- V - Karon Liner Type*
- L - Add L for Left Hand Thread
- K - Add K for Keyway (Keyslot definition per NAS 513)
- 4 - Ball Material Code (see chart below)
- A - Plating Code (see chart below)
- 2 - Race Material Code (see chart below)
- 2 - Housing Material Code (see chart below)

Ball/Race Material Code	Ball/Race Material	Ball Hardness	Race Hardness
1	PH13-8MO Stainless per AMS 5629	Rc 43 min.	N/A
2	17-4PH Stainless per AMS 5643	Rc 40-47	Rc 28-37
3	Inconel 718 per AMS 5663 or AMS 5662	*	*
4	Titanium 6AL4V per AMS 4928	*	*
5	316 Stainless per QQ-S-763 or AMS 5653	*	*
6	Inconel 625 per AMS 5666	*	*
7	Monel K-500 per QQ-N-286	*	*
8	Monel 400 per QQ-N-281	*	*
	Other materials are available. Please contact Kamatics for the proper part number.	*Ball and Race equivalent hardness per specification.	

Plating Code	Ball Plating Material (Ball OD, Side Faces Optional)
A	Chromium per SAE AMS-QQ-C-320
B	Karamite (Ceramic)
C	Nickel per SAE AMS-QQ-N-290
	Other platings are available. Please contact Kamatics for the proper part number.

*See Table 2 for liner options

KARON Lined Rod End Bearings

KNRF SERIES - FEMALE

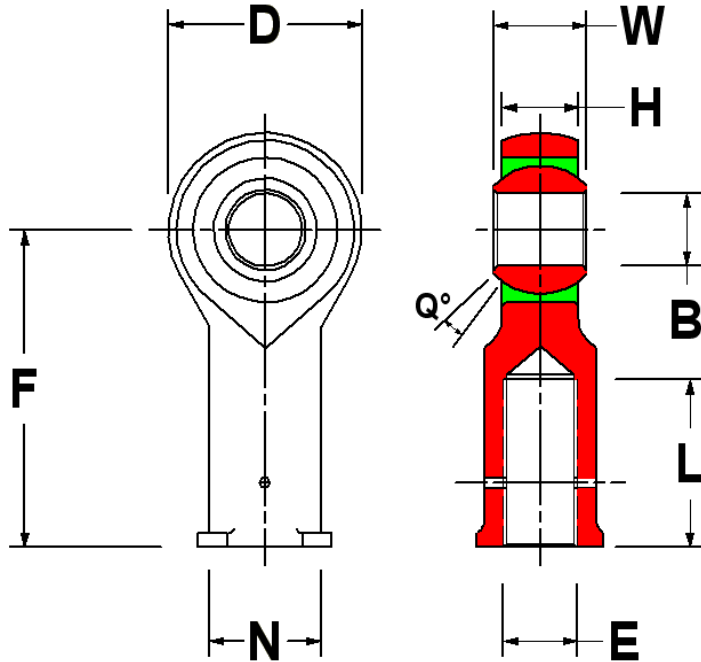

	B	D	W	H	L	F	N	E	Q°	Based on 170000 psi Tensile Strength
BEARING PART NUMBER	BORE DIA.	ROD END DIA.	BALL WIDTH	BODY WIDTH	THREAD DEPTH	BODY LENGTH	SHANK DIA.	THREAD SIZE UNF-3A UN-3A	MIS- ALIGN- MENT ANGLE	RADIAL ULTIMATE STATIC LOAD (LBS.)
	+0.0000 -0.0005	+0.010 -0.010	+0.000 -0.002	+0.005 -0.005	+0.062 -0.031	+0.010 -0.010	+0.010 -0.010			
KNR3F	0.1900	0.781	0.437	0.337	0.750	1.375	0.437	5/16-24	14°	15235
KNR4F	0.2500	0.781	0.437	0.337	0.750	1.375	0.437	5/16-24	13°	15235
KNR5F	0.3125	0.875	0.437	0.327	0.750	1.469	0.437	5/16-24	13°	17233
KNR6F	0.3750	1.000	0.500	0.416	0.937	1.625	0.562	3/8-24	8°	23826
KNR7F	0.4375	1.125	0.562	0.452	1.062	1.812	0.625	7/16-20	8°	28887
KNR8F	0.5000	1.312	0.625	0.515	1.125	2.125	0.750	1/2-20	7°	42561
KNR10F	0.6250	1.500	0.750	0.577	1.500	2.625	0.875	5/8-18	11°	48486
KNR12F	0.7500	1.750	0.875	0.687	1.750	2.875	1.000	3/4-16	11°	64564
KNR14F	0.8750	2.000	0.875	0.765	1.875	3.375	1.125	7/8-14	5°	91241
KNR16F	1.0000	2.750	1.375	1.015	2.125	4.125	1.688	1 1/4-12	14°	172231
KNR20F	1.2500	2.875	1.375	1.140	3.125	5.000	1.688	1 1/4-12	14°	171412

KARON Lined Rod End Bearings

KNRF SERIES - FEMALE

Part Number Example:

KNR 8 F V L K - 4 A 2 2

- KNR - KAron Marine self-lubricating bearing
- 8 - Size of bore in 1/16" increments
- F - Female Thread Rod End Bearing
- V - Karon Liner Type*
- L - Add L for Left Hand Thread
- K - Add K for Keyway (Keyslot definition per NAS 513)
- 4 - Ball Material Code (see chart below)
- A - Plating Code (see chart below)
- 2 - Race Material Code (see chart below)
- 2 - Housing Material Code (see chart below)

Ball/Race Material Code	Ball/Race Material	Ball Hardness	Race Hardness
1	PH13-8MO Stainless per AMS 5629	Rc 43 min.	N/A
2	17-4PH Stainless per AMS 5643	Rc 40-47	Rc 28-37
3	Inconel 718 per AMS 5663 or AMS 5662	*	*
4	Titanium 6AL4V per AMS 4928	*	*
5	316 Stainless per QQ-S-763 or AMS 5653	*	*
6	Inconel 625 per AMS 5666	*	*
7	Monel K-500 per QQ-N-286	*	*
8	Monel 400 per QQ-N-281	*	*
	Other materials are available. Please contact Kamatics for the proper part number.	*Ball and Race equivalent hardness per specification.	

Plating Code	Ball Plating Material (Ball OD, Side Faces Optional)
A	Chromium per SAE AMS-QQ-C-320
B	Karamite (Ceramic)
C	Nickel per SAE AMS-QQ-N-290
	Other platings are available. Please contact Kamatics for the proper part number.

*See Table 2 for liner options

KARON Lined Rod End Bearings

KNRMH SERIES – HEAVY DUTY

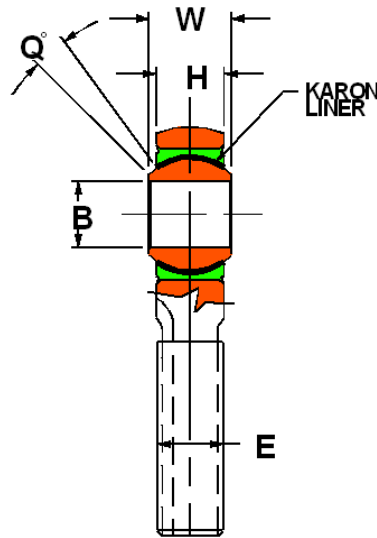
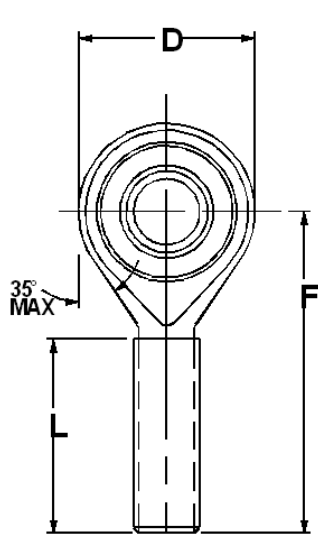

	B	D	W	H	L	F	E	Q°	Based on 170000 psi Tensile Strength
BEARING PART NUMBER	BORE DIA.	ROD END DIA.	BALL WIDTH	BODY WIDTH	THREAD LENGTH	BODY LENGTH	THREAD SIZE UNF-3A UN-3A	MIS- ALIGN- MENT ANGLE	RADIAL ULTIMATE STATIC LOAD (LBS.)
	+0.000 -0.0005	+0.010 -0.010	+0.000 -0.002	+0.005 -0.005	+0.062 -0.031	+0.010 -0.010			
KNR4MH	0.2500	0.812	0.344	0.250	1.000	1.718	5/16-24	12°	9846
KNR5MH	0.3125	1.000	0.437	0.327	1.250	2.062	3/8-24	12°	19923
KNR6MH	0.3750	1.125	0.500	0.375	1.375	2.312	7/16-20	12°	20975
KNR7MH	0.4375	1.218	0.562	0.452	1.562	2.500	9/16-18	8°	89018
KNR8MH	0.5000	1.437	0.688	0.500	1.687	2.875	5/8-18	13°	35996
KNR10MH	0.6250	1.750	0.812	0.625	2.000	3.312	3/4-16	10°	62030
KNR12MH	0.7500	2.000	1.000	0.750	2.312	3.500	7/8-14	14°	72573
KNR14MH	0.8750	2.562	1.125	0.875	2.500	4.500	1-12	19°	121956
KNR16MH	1.0000	3.000	1.375	1.000	2.812	5.000	1 1/4-12	16°	146742
KNR20MH	1.2500	3.625	1.625	1.125	3.000	5.500	1 1/2-12	17°	233567
KNR24MH	1.5000	3.750	1.687	1.218	3.375	6.000	1 3/4-12	12°	217260
KNR28MH	1.7500	4.375	1.812	1.312	4.125	7.000	2-12	11°	298592
KNR32MH	2.0000	5.000	1.750	1.500	4.750	8.125	2 1/4-12	4°	423191
KNR36MH	2.2500	5.437	1.969	1.687	5.875	9.250	2 1/2-12	4°	498419
KNR40MH	2.5000	5.750	2.187	1.875	7.000	10.625	2 3/4-12	4°	542196
KNR44MH	2.7500	6.500	2.406	2.062	7.250	11.500	3-12	5°	703165

KARON Lined Rod End Bearings

KNRMH SERIES – HEAVY DUTY MALE

Part Number Example:

KNR 8 M H V L K - 4 A 2 2

- KNR - Karon Marine self-lubricating bearing
- 8 - Size of bore in 1/16” increments
- M - Male Thread Rod End Bearing
- H - Heavy Duty Series
- V - Karon Liner Type*
- L - Add L for Left Hand Thread
- K - Add K for Keyway (Keyslot definition per NAS 513)
- 4 - Ball Material Code (see chart below)
- A - Plating Code (see chart below)
- 2 - Race Material Code (see chart below)
- 2 - Housing Material Code (see chart below)

Ball/Race Material Code	Ball/Race Material	Ball Hardness	Race Hardness
1	PH13-8MO Stainless per AMS 5629	Rc 43 min.	N/A
2	17-4PH Stainless per AMS 5643	Rc 40-47	Rc 28-37
3	Inconel 718 per AMS 5663 or AMS 5662	*	*
4	Titanium 6AL4V per AMS 4928	*	*
5	316 Stainless per QQ-S-763 or AMS 5653	*	*
6	Inconel 625 per AMS 5666	*	*
7	Monel K-500 per QQ-N-286	*	*
8	Monel 400 per QQ-N-281	*	*
	Other materials are available. Please contact Kamatics for the proper part number.	*Ball and Race equivalent hardness per specification.	

Plating Code	Ball Plating Material (Ball OD, Side Faces Optional)
A	Chromium per SAE AMS-QQ-C-320
B	Karamite (Ceramic)
C	Nickel per SAE AMS-QQ-N-290
	Other platings are available. Please contact Kamatics for the proper part number.

*See Table 2 for liner options

KARON Lined Rod End Bearings

KNRME SERIES - HIGH MISALIGNMENT MALE

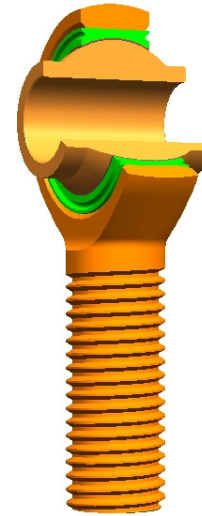
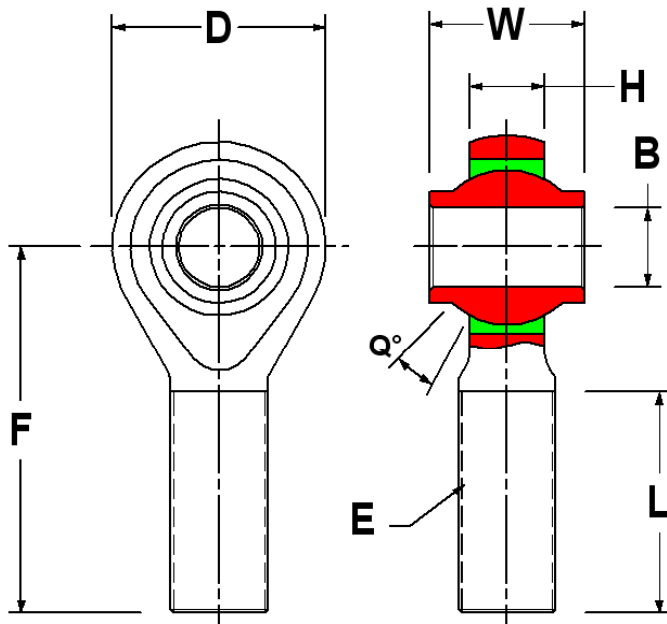

	B	D	W	H	L	F	E	Q°	CALCULATED FOR AISI 4340
BEARING PART NUMBER	BORE DIA.	ROD END DIA.	BALL WIDTH	BODY WIDTH	THREAD LENGTH	BODY LENGTH	THREAD SIZE UNF-3A UN-3A	MIS-ALIGNMENT ANGLE	RADIAL ULTIMATE STATIC LOAD (LBS.)
	+0.000 -0.0005	+0.010 -0.010	+0.000 -0.005	+0.005 -0.005	+0.062 -0.031	+0.010 -0.010			
KNR3ME	0.1900	0.781	0.560	0.265	1.000	1.562	5/16-24	20°	12854
KNR4ME	0.2500	1.000	0.593	0.331	1.250	1.938	3/8-24	24°	26952
KNR5ME	0.3125	1.125	0.813	0.331	1.375	2.125	7/16-20	21°	22653
KNR6ME	0.3750	1.125	0.813	0.355	1.375	2.125	7/16-20	23°	24264
KNR7ME	0.4375	1.312	0.875	0.355	1.500	2.438	1/2-20	22°	31599
KNR8ME	0.5000	1.500	0.937	0.411	1.625	2.625	5/8-18	20°	41428
KNR10ME	0.6250	1.750	1.200	0.577	1.750	2.875	3/4-16	17°30'	61625
KNR12ME	0.7500	2.000	1.280	0.630	1.875	3.375	7/8-14	19°	79841
KNR14ME	0.8750	2.200	1.400	0.635	2.000	3.750	7/8-14	18°	85058
KNR16ME	1.0000	2.750	1.875	0.845	2.125	4.125	1 1/4-12	21°	147782
KNR20ME	1.2500	3.125	1.875	1.015	2.875	5.000	1 1/4-12	20°	177878
KNR24ME	1.5000	3.750	2.250	1.170	3.750	6.500	1 1/2-12	21°	250051
KNR28ME	1.7500	4.500	2.875	1.250	5.000	8.000	2-12	23°	315711

KARON Lined Rod End Bearings

KNRME SERIES - HIGH MISALIGNMENT MALE

Part Number Example:

KNR 8 M E V L K - 4 A 2 2

- KNR - Karon Marine self-lubricating bearing
- 8 - Size of bore in 1/16" increments
- M - Male Thread Rod End Bearing
- E - High Misalignment Series
- V - Karon Liner Type*
- L - Add L for Left Hand Thread
- K - Add K for Keyway (Keyslot definition per NAS 513)
- 4 - Ball Material Code (see chart below)
- A - Plating Code (see chart below)
- 2 - Race Material Code (see chart below)
- 2 - Housing Material Code (see chart below)

Ball/Race Material Code	Ball/Race Material	Ball Hardness	Race Hardness
1	PH13-8MO Stainless per AMS 5629	Rc 43 min.	N/A
2	17-4PH Stainless per AMS 5643	Rc 40-47	Rc 28-37
3	Inconel 718 per AMS 5663 or AMS 5662	*	*
4	Titanium 6AL4V per AMS 4928	*	*
5	316 Stainless per QQ-S-763 or AMS 5653	*	*
6	Inconel 625 per AMS 5666	*	*
7	Monel K-500 per QQ-N-286	*	*
8	Monel 400 per QQ-N-281	*	*
Other materials are available. Please contact Kamatics for the proper part number.		*Ball and Race equivalent hardness per specification.	

Plating Code	Ball Plating Material (Ball OD, Side Faces Optional)
A	Chromium per SAE AMS-QQ-C-320
B	Karamite (Ceramic)
C	Nickel per SAE AMS-QQ-N-290
Other platings are available. Please contact Kamatics for the proper part number.	

*See Table 2 for liner options

KARON Lined Rod End Bearings

KNRFE SERIES - HIGH MISALIGNMENT FEMALE

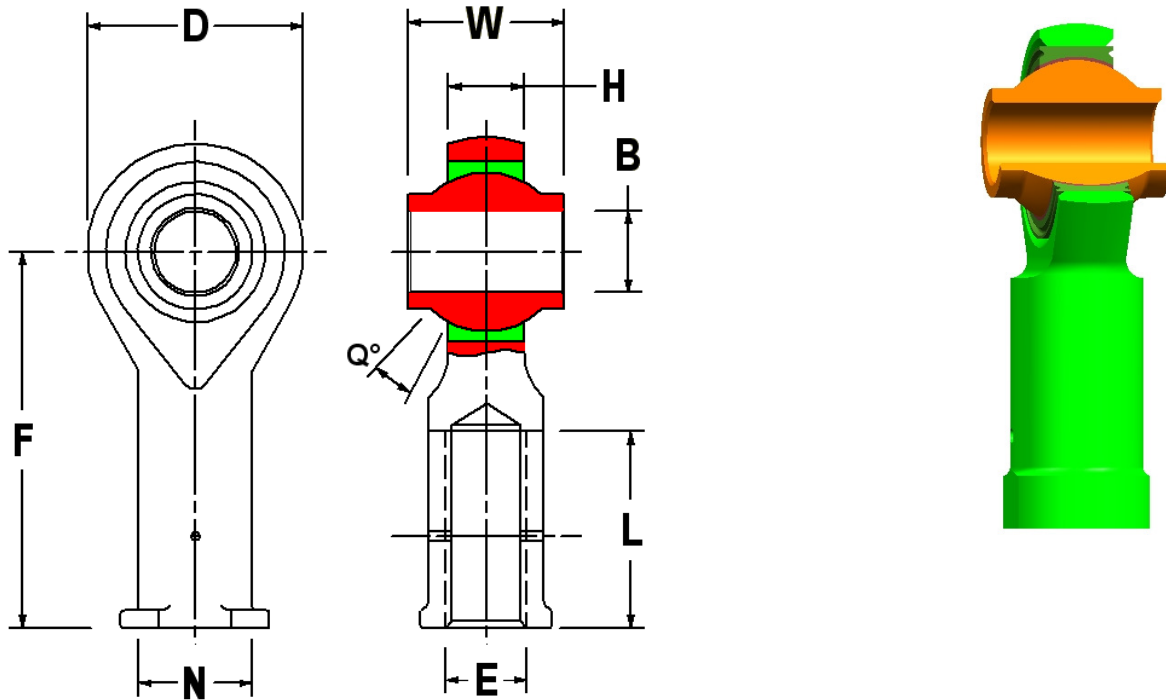

	B	D	W	H	L	F	N	E	Q°	Based on 170000 psi Tensile Strength
BEARING PART NUMBER	BORE DIA.	ROD END DIA.	BALL WIDTH	BODY WIDTH	THREAD LENGTH	BODY LENGTH	SHANK DIA.	THREAD SIZE UNF-3A UN-3A	MIS- ALIGN- MENT ANGLE	RADIAL ULTIMATE STATIC LOAD (LBS.)
	+0.000 -0.005	+0.010 -0.010	+0.000 -0.005	+0.005 -0.005	+0.062 -0.031	+0.010 -0.010	+0.010 -0.010			
KNR3FE	0.1900	0.781	0.560	0.265	0.750	1.375	0.437	5/16-24	20°	12854
KNR4FE	0.2500	1.000	0.593	0.337	0.937	1.625	0.562	3/8-24	24°	27397
KNR5FE	0.3125	1.125	0.813	0.355	1.062	1.812	0.625	7/16-20	21°	24130
KNR6FE	0.3750	1.125	0.813	0.355	1.062	1.812	0.625	7/16-20	23°	24264
KNR7FE	0.4375	1.312	0.875	0.355	1.125	2.125	0.750	1/2-20	23°	31599
KNR8FE	0.5000	1.500	0.937	0.411	1.500	2.625	0.875	5/8-18	21°	41428
KNR10FE	0.6250	1.750	1.200	0.577	1.750	2.875	1.000	3/4-16	17°30'	61625
KNR12FE	0.7500	2.000	1.280	0.630	1.875	3.375	1.125	7/8-14	19°	79841
KNR14FE	0.8750	2.200	1.400	0.635	2.000	3.750	1.125	7/8-14	18°	85058
KNR16FE	1.0000	2.750	1.875	0.845	2.125	4.125	1.688	1 1/4-12	21°	147782
KNR20FE	1.2500	3.125	1.875	1.015	3.125	5.000	1.688	1 1/4-12	20°	177878

KARON Lined Rod End Bearings

KNRFE SERIES - HIGH MISALIGNMENT FEMALE

Part Number Example:

KNR 8 F E V L K - 4 A 2 2

- KNR - Karon Marine self-lubricating bearing
- 8 - Size of bore in 1/16" increments
- F - Female Thread Rod End Bearing
- E - High Misalignment Series
- V - Karon Liner Type*
- L - Add L for Left Hand Thread
- K - Add K for Keyway (Keyslot definition per NAS 513)
- 4 - Ball Material Code (see chart below)
- A - Plating Code (see chart below)
- 2 - Race Material Code (see chart below)
- 2 - Housing Material Code (see chart below)

Ball/Race Material Code	Ball/Race Material	Ball Hardness	Race Hardness
1	PH13-8MO Stainless per AMS 5629	Rc 43 min.	N/A
2	17-4PH Stainless per AMS 5643	Rc 40-47	Rc 28-37
3	Inconel 718 per AMS 5663 or AMS 5662	*	*
4	Titanium 6AL4V per AMS 4928	*	*
5	316 Stainless per QQ-S-763 or AMS 5653	*	*
6	Inconel 625 per AMS 5666	*	*
7	Monel K-500 per QQ-N-286	*	*
8	Monel 400 per QQ-N-281	*	*
	Other materials are available. Please contact Kamatics for the proper part number.	*Ball and Race equivalent hardness per specification.	

Plating Code	Ball Plating Material (Ball OD, Side Faces Optional)
A	Chromium per SAE AMS-QQ-C-320
B	Karamite (Ceramic)
C	Nickel per SAE AMS-QQ-N-290
	Other platings are available. Please contact Kamatics for the proper part number.

*See Table 2 for liner options

Karon Lined Journal Bearings

KNRJ SERIES - STRAIGHT

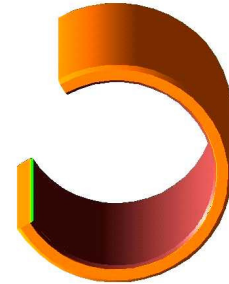
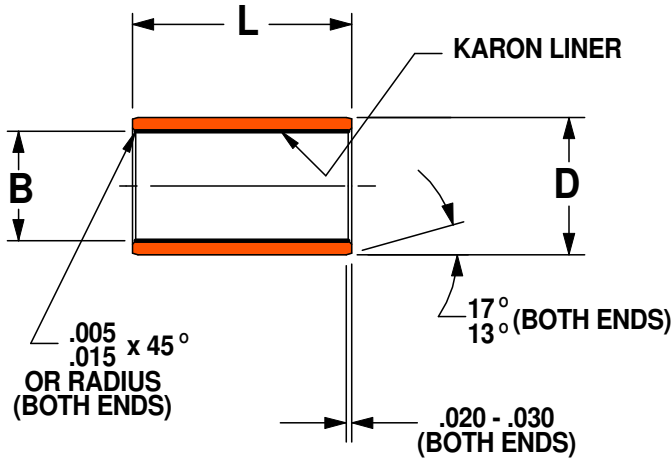

BEARING PART NUMBER	B		D		L												
	BORE DIA.		OUTSIDE DIA.		ADD SUFFIX FOR DESIRED LENGTH												
					CODE	LENGTH	CODE	LENGTH									
KNRJ4	0.2525	+.0000 -.0010	0.3765	+.0000 -.0005	-008	0.250	-066	2.062	+.005 -.005								
KNRJ5	0.3150		0.4390		-009	0.281	-068	2.125									
KNRJ6	0.3775		0.5640		-010	0.312	-070	2.187									
KNRJ7	0.4400		0.6265		-011	0.344	-072	2.250									
KNRJ8	0.5025		0.6890		-012	0.375	-074	2.312									
KNRJ9	0.5650		0.7515		-014	0.437	-076	2.375									
KNRJ10	0.6275		0.8765		-016	0.500	-078	2.437									
KNRJ12	0.7535		1.0020		-018	0.562	-080	2.500									
KNRJ14	0.8785		1.1270		-020	0.625	-082	2.562									
KNRJ16	1.0035		1.2520		-022	0.687	-084	2.625									
KNRJ18	1.1285		1.3770		-024	0.750	-086	2.687									
KNRJ20	1.2535		1.5020		-026	0.812	-088	2.750									
KNRJ22	1.3800		1.6275		-028	0.875	-096	3.000									
KNRJ24	1.5050		1.7525		-030	0.937	-104	3.250									
KNRJ26	1.6300		1.8775		-032	1.000	-112	3.500									
KNRJ28	1.7550		2.0025		-034	1.062	-120	3.750									
KNRJ30	1.8800		2.1275		-036	1.125	-128	4.000									
KNRJ32	2.0050		2.3775		-038	1.187	-136	4.250									
KNRJ36	2.2500		2.6275		-040	1.250	-144	4.500									
KNRJ40	2.5060		2.8775		-042	1.312	-152	4.750									
KNRJ44	2.7560	3.1275	-044	1.375	-160	5.000											
KNRJ48	3.0060	3.5025	-046	1.437	-168	5.250											
KNRJ52	3.2560	3.7525	-048	1.500	-176	5.500											
KNRJ56	3.5060	4.0025	-050	1.562	-184	5.750											
KNRJ60	3.7560	4.2525	-052	1.625	-192	6.000											
KNRJ64	4.0060	4.5025	-054	1.687	-208	6.500											
KNRJ68	4.2560	4.7525	-056	1.750	-224	7.000											
KNRJ72	4.5070	5.0031	-058	1.812	-240	7.500											
KNRJ76	4.7570	5.2531	-060	1.875	-256	8.000											
KNRJ80	5.0070	5.5031	-062	1.937	-272	8.500											
KNRJ88	5.5070	6.0031	-064	2.000	-288	9.000											
KNRJ96	6.0070	6.5031	+.0000 -.0020		Note: the length tabulation block "L" is intended as an aid in ordering a desired bearing length and not to imply that all lengths listed are available or suggested for all part numbers listed.												
KNRJ104	6.5070	7.0031															
KNRJ112	7.0070	7.5031															
KNRJ120	7.5070	8.0031															
KNRJ128	8.0070	8.5031	+.0000 -.0030								Normally, for highly loaded applications, L/D ratio of 2 is considered a maximum due to mating shaft bending considerations.						

KAron Lined Journal Bearings

KNRJ SERIES - STRAIGHT

Part Number Example:

KNR J 8 - V - 016 - 1 A

- KNR - KAron Marine self-lubricating bearing
- J - Journal Bearing
- 8 - Size of bore in 1/16" increments
- V - Karon Liner Type*
- 016 - Length in 1/32" increments
- 1 - Journal Material Code (see chart below)
- A - Plating Material Code (see chart below)

Ball/Race Material Code	Ball/Race Material	Ball Hardness	Race Hardness
1	PH13-8MO Stainless per AMS 5629	Rc 43 min.	N/A
2	17-4PH Stainless per AMS 5643	Rc 40-47	Rc 28-37
3	Inconel 718 per AMS 5663 or AMS 5662	*	*
4	Titanium 6AL4V per AMS 4928	*	*
5	316 Stainless per QQ-S-763 or AMS 5653	*	*
6	Inconel 625 per AMS 5666	*	*
7	Monel K-500 per QQ-N-286	*	*
8	Monel 400 per QQ-N-281	*	*
	Other materials are available. Please contact Kamatics for the proper part number.	*Ball and Race equivalent hardness per specification.	

Plating Code	Plating Material OD, Adjacent Surfaces Optional
A	Cadmium per SAE AMS-QQ-P-416
B	Zink-Nickel per SAE AMS-QQ-P-416, Type II, Class 2 or SAE AMS 2417, Type 2 (OD tol = ± .0005)
	Other platings are available. Please contact Kamatics for the proper part number.

*See Table 2 for liner options

KAron Lined Journal Bearings

KNRJ-UD SERIES - FLANGED

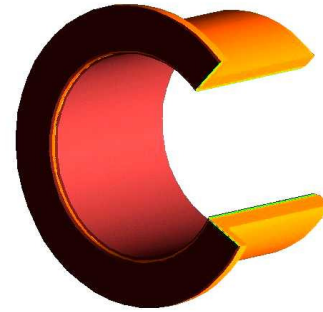
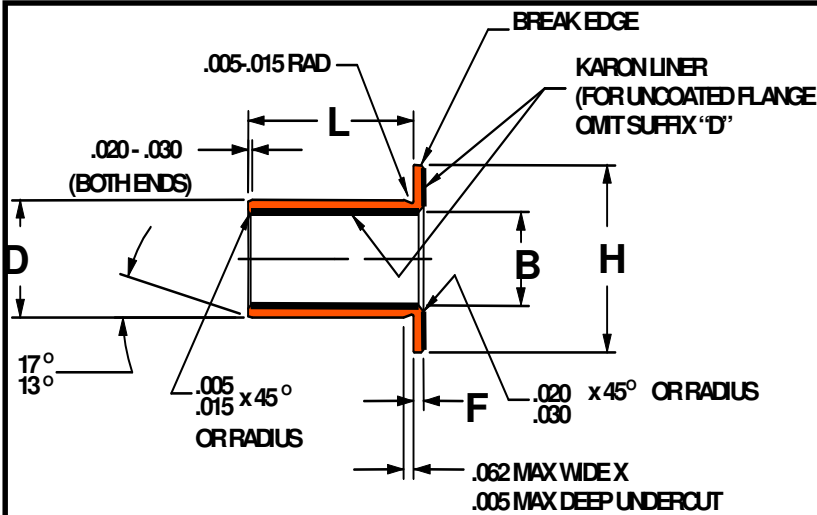

BEARING PART NUMBER	B		D		H		F		L				
	BORE DIAMETER		OUTSIDE DIAMETER		FLANGE DIAMETER		FLANGE WIDTH +/- .005		ADD SUFFIX FOR DESIRED LENGTH				
	CODE	LENGTH	CODE	LENGTH	CODE	LENGTH	CODE	LENGTH	CODE	LENGTH	CODE	LENGTH	
KNRJ4-UD	0.2525		0.3765		0.500		0.125	-008	0.250	-066	2.062		
KNRJ5-UD	0.3150		0.4390		0.562		0.125	-009	0.281	-068	2.125		
KNRJ6-UD	0.3775		0.5640		0.625		0.125	-010	0.312	-070	2.187		
KNRJ7-UD	0.4400		0.6265		0.750		0.125	-011	0.344	-072	2.250		
KNRJ8-UD	0.5025		0.6890		0.875		0.125	-012	0.375	-074	2.312		
KNRJ9-UD	0.5650		0.7515		1.062		0.125	-014	0.437	-076	2.375		
KNRJ10-UD	0.6275		0.8765		1.188		0.125	-016	0.500	-078	2.437		
KNRJ12-UD	0.7535		1.0020		1.312		0.125	-018	0.562	-080	2.500		
KNRJ14-UD	0.8785		1.1270		1.500		0.125	-020	0.625	-082	2.562		
KNRJ16-UD	1.0035	+ .0000 - .0010	1.2520	+ .0000 - .0005	1.750	+ .010 - .010	0.125	-022	0.687	-084	2.625		
KNRJ18-UD	1.1285		1.3770		1.890		0.125	-024	0.750	-086	2.687		
KNRJ20-UD	1.2535		1.5020		2.015		0.125	-026	0.812	-088	2.750		
KNRJ22-UD	1.3800		1.6275		2.140		0.125	-028	0.875	-096	3.000		
KNRJ24-UD	1.5050		1.7525		2.265		0.125	-030	0.937	-104	3.250		
KNRJ26-UD	1.6300		1.8775		2.390		0.125	-032	1.000	-112	3.500		
KNRJ28-UD	1.7550		2.0025		2.515		0.125	-034	1.062	-120	3.750		
KNRJ30-UD	1.8800		2.1275		2.640		0.125	-036	1.125	-128	4.000		
KNRJ32-UD	2.0050		2.3775		3.000		0.125	-038	1.187	-136	4.250		
KNRJ36-UD	2.2550		2.6275		3.250		0.125	-040	1.250	-144	4.500		
KNRJ40-UD	2.5060		2.8775		3.500		0.125	-042	1.312	-152	4.750		
KNRJ44-UD	2.7560		3.1275		3.750		0.125	-044	1.375	-160	5.000		
KNRJ48-UD	3.0060		3.5025		4.000		0.125	-046	1.437	-168	5.250		
KNRJ52-UD	3.2570		3.7525		4.250		0.125	-048	1.500	-176	5.500		
KNRJ56-UD	3.5060		4.0025		4.500		0.125	-050	1.562	-184	5.750		
KNRJ60-UD	3.7560	+ .0000 - .0020	4.2525	+ .0000 - .0015	4.750	+ .015 - .015	0.125	-052	1.625	-192	6.000		
KNRJ64-UD	4.0060		4.5025		5.000		0.125	-054	1.687	-208	6.500		
KNRJ68-UD	4.2560		4.7525		5.250		0.125	-056	1.750	-224	7.000		
KNRJ72-UD	4.5070		5.0031		5.500		0.125	-058	1.812	-240	7.500		
KNRJ76-UD	4.7570		5.2531		5.750		0.125	-060	1.875	-256	8.000		
KNRJ80-UD	5.0070		5.5031		6.000		0.125	-062	1.937	-272	8.500		
KNRJ88-UD	5.5070		6.0031		6.500		0.125	-064	2.000	-288	9.000		
KNRJ96-UD	6.0070		6.5031	+ .0000 - .0020	7.000	+ .030 - .030	0.250						
KNRJ104-UD	6.5070		7.0031		7.500		0.250						
KNRJ112-UD	7.0070		7.5031		8.000		0.250						
KNRJ120-UD	7.5070		8.0031		8.500		0.250						
KNRJ128-UD	8.0070		8.5031		9.000		0.250						

Note: the length tabulation block "L" is intended as an aid in ordering a desired bearing length and not to imply that all lengths listed are available or suggested for all part numbers listed.

Normally, for highly loaded applications, L/D ratio of 2 is considered a maximum due to mating shaft bending considerations.

KAron Lined Journal Bearings

KNRJ-UD SERIES - FLANGED

Part Number Example:

KNR J 8 - U D V - 016 - 1 A

- KNR - KAron Marine self-lubricating bearing
- J - Journal Bearing
- 8 - Size of bore in 1/16" increments
- U - Add U for flanged bearing
- D - Add D for KAron liner on flange
- V - KAron Liner Type*
- 016 - Length in 1/32" increments
- 1 - Journal Material Code (see chart below)
- A - Plating Material Code (see chart below)

Ball/Race Material Code	Ball/Race Material	Ball Hardness	Race Hardness
1	PH13-8MO Stainless per AMS 5629	Rc 43 min.	N/A
2	17-4PH Stainless per AMS 5643	Rc 40-47	Rc 28-37
3	Inconel 718 per AMS 5663 or AMS 5662	*	*
4	Titanium 6AL4V per AMS 4928	*	*
5	316 Stainless per QQ-S-763 or AMS 5653	*	*
6	Inconel 625 per AMS 5666	*	*
7	Monel K-500 per QQ-N-286	*	*
8	Monel 400 per QQ-N-281	*	*
	Other materials are available. Please contact Kamatics for the proper part number.	*Ball and Race equivalent hardness per specification.	

Plating Code	Plating Material OD, Adjacent Surfaces Optional
A	Cadmium per SAE AMS-QQ-P-416
B	Zink-Nickel per SAE AMS-QQ-P-416, Type II, Class 2 or SAE AMS 2417, Type 2 (OD tol = ± .0005)
	Other platings are available. Please contact Kamatics for the proper part number.

*See Table 2 for liner options

Karon Lined, Composite Backed Journal Bearings

KRCJ SERIES - STRAIGHT

KAMATICS FIBERLON™ BEARINGS

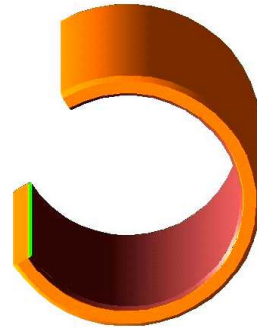
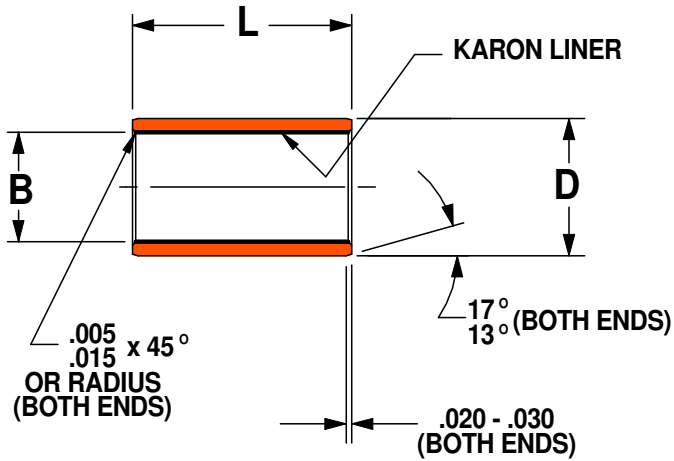

BEARING PART NUMBER	B		D		L					
	BORE DIA.		OUTSIDE DIA.		ADD SUFFIX FOR DESIRED LENGTH					
					CODE	LENGTH	CODE	LENGTH		
KRCJ4	0.2515		0.3760		-008	0.250	-066	2.062		
KRCJ5	0.3140		0.4386		-009	0.281	-068	2.125		
KRCJ6	0.3765		0.5012		-010	0.312	-070	2.187		
KRCJ7	0.4390		0.5638		-011	0.344	-072	2.250		
KRCJ8	0.5015		0.6265		-012	0.375	-074	2.312		
KRCJ9	0.5640		0.6892		-014	0.437	-076	2.375		
KRCJ10	0.6265		0.8142		-016	0.500	-078	2.437		
KRCJ11	0.6890		0.8767		-018	0.562	-080	2.500		
KRCJ12	0.7515	+0.0000	0.9393	+0.0005	-020	0.625	-082	2.562		
KRCJ14	0.8765	-0.0010	1.0645	-0.0005	-022	0.687	-084	2.625		
KRCJ16	1.0015		1.1898		-024	0.750	-086	2.687		
KRCJ18	1.1265		1.3148		-026	0.812	-088	2.750		
KRCJ20	1.2515		1.4398		-028	0.875	-096	3.000		
KRCJ22	1.3765		1.5648		-030	0.937	-104	3.250		
KRCJ24	1.5015		1.7523		-032	1.000	-112	3.500		
KRCJ26	1.6265		1.8773		-034	1.062	-120	3.750		
KRCJ28	1.7515		2.0023		-036	1.125	-128	4.000		
KRCJ32	2.0015		2.2523		-038	1.187	-136	4.250		
					-040	1.250	-144	4.500		
					-042	1.312	-152	4.750		
					-044	1.375	-160	5.000		
					-046	1.437	-168	5.250		
					-048	1.500	-176	5.500		
					-050	1.562	-184	5.750		
					-052	1.625	-192	6.000		
					-054	1.687	-208	6.500		
					-056	1.750	-224	7.000		
					-058	1.812	-240	7.500		
					-060	1.875	-256	8.000		
					-062	1.937	-272	8.500		
					-064	2.000	-288	9.000		

Note: the length tabulation block "L" is intended as an aid in ordering a desired bearing length and not to imply that all lengths listed are available or suggested for all part numbers listed.

Normally, for highly loaded applications, L/D ratio of 2 is considered a maximum due to mating shaft bending considerations.

KAron Lined, Composite Backed Journal Bearings

KRCJ SERIES - STRAIGHT

Part Number Example:

KRC J 8 - V - 016 - 1 A

KRC - KAron Marine self-lubricating bearing

J - Journal Bearing

8 - Size of bore in 1/16" increments

V - KAron Liner Type †

016 - Length in 1/32" increments

† KAron V, B or VS

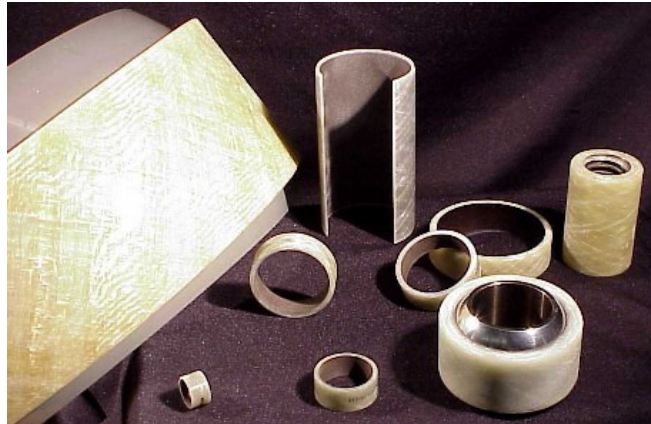

Select KAron V Liner System for Kamatics Fiberlon™ Bearing
Qualified to MIL-B-85560 Bearing

KAMATICS FIBERLON™ BEARINGS

- The only bearing system which qualified to MIL-B-85560 with a fully machineable liner that is also self-lubricating.
- Dynamic operation greater than 20,000 psi (138 MPa).
- Ultimate strength greater than 60,000 psi (414 Mpa).
- One quarter the weight of stainless steel bearings.
- Quiet Operating
- Resists chemical degradation with no galvanic corrosion.
- Superior fluid/chemical resistance

Karon Lined, Composite Backed Journal Bearings

KRCJ-UD SERIES - FLANGED

KAMATICS FIBERLON™ BEARINGS

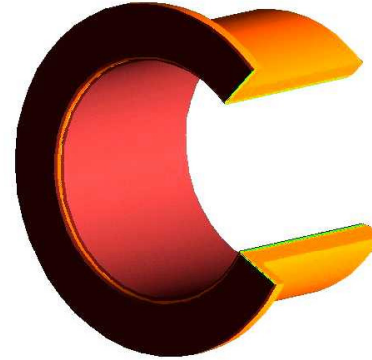
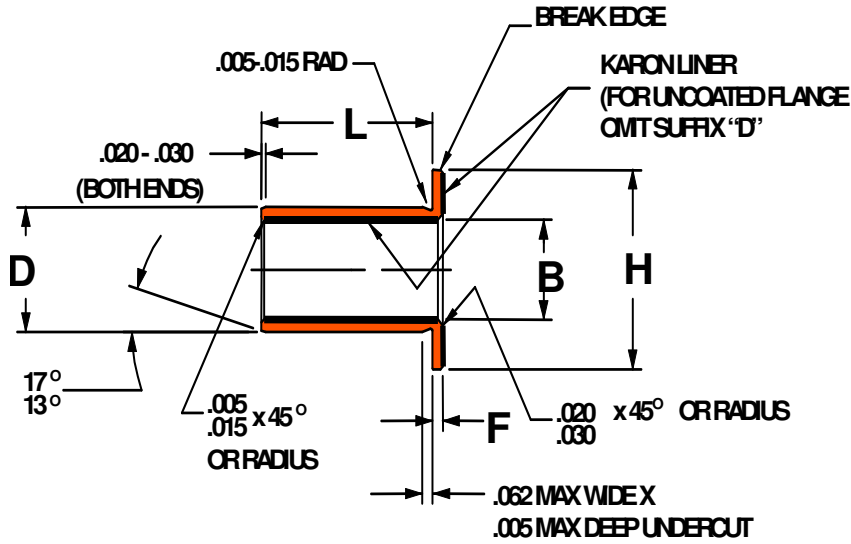

M85560/2	B		D		H		F		L				
BEARING PART NUMBER	BORE DIAMETER		OUTSIDE DIAMETER		FLANGE DIAMETER		FLANGE WIDTH		ADD SUFFIX FOR DESIRED LENGTH				
									CODE	LENGTH	CODE	LENGTH	
KRCJ4-UD	0.2515		0.3760		0.750		.0625		-008	0.250	-066	2.062	+.005 -.005
KRCJ5-UD	0.3140		0.4386		0.812				-009	0.281	-068	2.125	
KRCJ6-UD	0.3765		0.5012		0.875				-010	0.312	-070	2.187	
KRCJ7-UD	0.4390		0.5638		0.937				-011	0.344	-072	2.250	
KRCJ8-UD	0.5015		0.6265		1.000				-012	0.375	-074	2.312	
KRCJ9-UD	0.5640		0.6892		1.125				-014	0.437	-076	2.375	
KRCJ10-UD	0.6265		0.8142		1.250				-016	0.500	-078	2.437	
KRCJ11-UD	0.6890		0.8767		1.375				-018	0.562	-080	2.500	
KRCJ12-UD	0.7515	+.0000 -.0010	0.9393	+.0005 -.0005	1.500	+.000 -.020			-020	0.625	-082	2.562	
KRCJ14-UD	0.8765		1.0645		1.625				-022	0.687	-084	2.625	
KRCJ16-UD	1.0015		1.1898		1.750				-024	0.750	-086	2.687	
KRCJ18-UD	1.1265		1.3148		1.875				-026	0.812	-088	2.750	
KRCJ20-UD	1.2515		1.4398		2.000				-028	0.875	-096	3.000	
KRCJ22-UD	1.3765		1.5648		2.125				-030	0.937	-104	3.250	
KRCJ24-UD	1.5015		1.7523		2.250				-032	1.000	-112	3.500	
KRCJ26-UD	1.6265		1.8773		2.375				-034	1.062	-120	3.750	
KRCJ28-UD	1.7515		2.0023		2.500		-036	1.125	-128	4.000			
KRCJ32-UD	2.0015		2.2523		2.750		-038	1.187	-136	4.250			
							-040	1.250	-144	4.500			
							-042	1.312	-152	4.750			
							-044	1.375	-160	5.000			
							-046	1.437	-168	5.250			
							-048	1.500	-176	5.500			
							-050	1.562	-184	5.750			
				-052	1.625	-192	6.000						
				-054	1.687	-208	6.500						
				-056	1.750	-224	7.000						
				-058	1.812	-240	7.500						
				-060	1.875	-256	8.000						
				-062	1.937	-272	8.500						
				-064	2.000	-288	9.000						

Note: the length tabulation block "L" is intended as an aid in ordering a desired bearing length and not to imply that all lengths listed are available or suggested for all part numbers listed.

Normally, for highly loaded applications, L/D ratio of 2 is considered a maximum due to mating shaft bending considerations.

KAron Lined, Composite Backed Journal Bearings

KRCJ-UD SERIES - FLANGED

Part Number Example:

KRC J 8 - V - 016 - 1 A

KRC - KAron Marine self-lubricating bearing

J - Journal Bearing

8 - Size of bore in 1/16" increments

U - Flanged Bearing

D - KAron Liner on Flange

V - KAron Liner Type †

016 - Length in 1/32" increments

† KAron V, B or VS

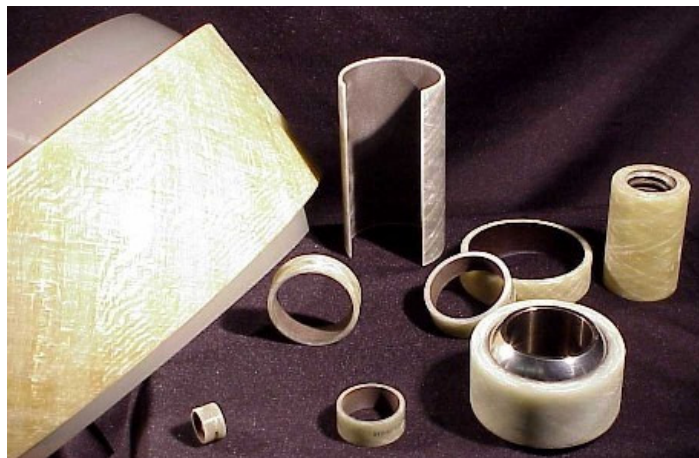

Select KAron V Liner System for Kamatics Fiberlon™ Bearing
Qualified to MIL-B-85560 Bearing

KAMATICS FIBERLON™ BEARINGS

- The only bearing system which qualified to MIL-B-85560 with a ***fully machineable*** liner that is also self-lubricating.
- Dynamic operation greater than 20,000 psi (138 MPa).
- Ultimate strength greater than 60,000 psi (414 Mpa).
- One quarter the weight of stainless steel bearings.
- Quiet Operating
- Resists chemical degradation with no galvanic corrosion.
- Superior fluid/chemical resistance

KAron Applications



LHD
(AMPHIBIOUS
ASSAULT SHIP)



DD/CG/FFG (DESTROYER)

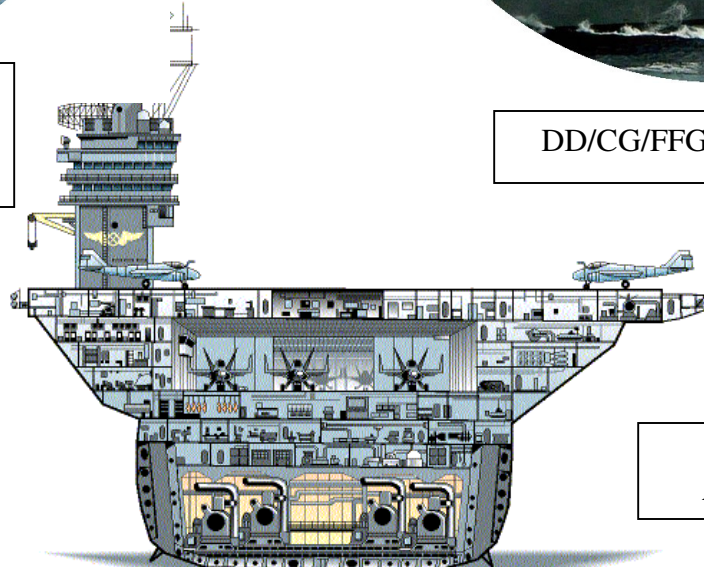

CV/CVN
AIRCRAFT CARRIER



LCAC (AIR CUSION LANDING CRAFT)

VIRGINIA CLASS

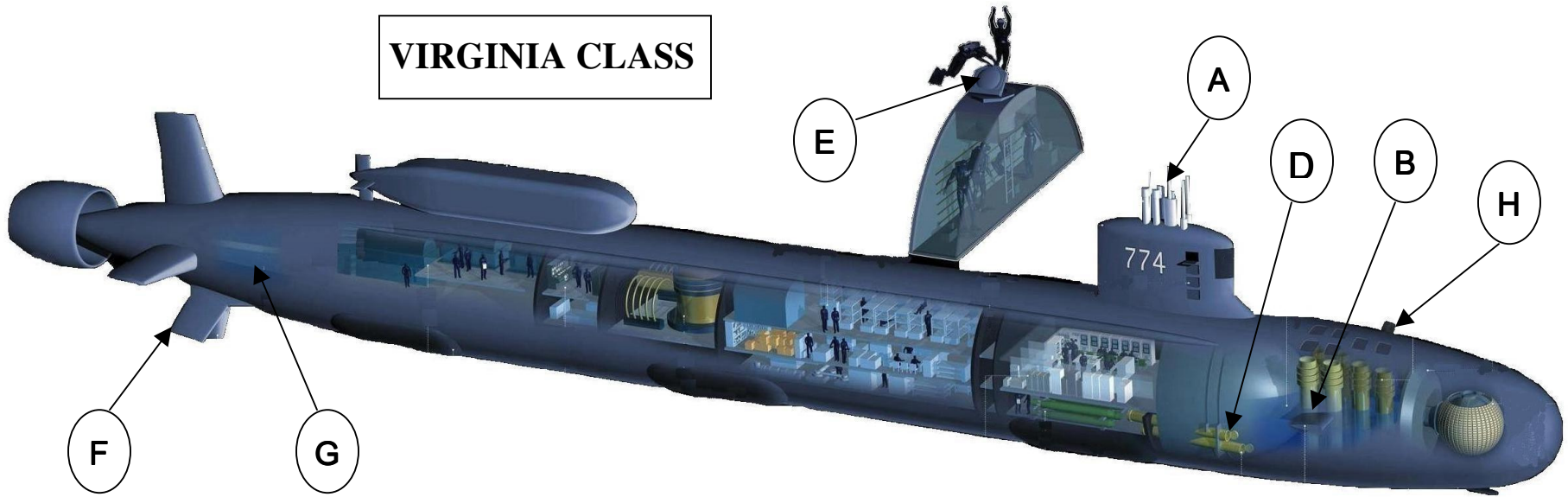

**A: ANTENNA BUSHING B: BOW PLANE C: WEAPONS HATCH D: TORPEDO SHUTTER DOOR E: ESCAPE HATCH
F: RUDDER G: BALLAST TANK VALVE H: VERT. LAUNCH HATCH**

LA CLASS

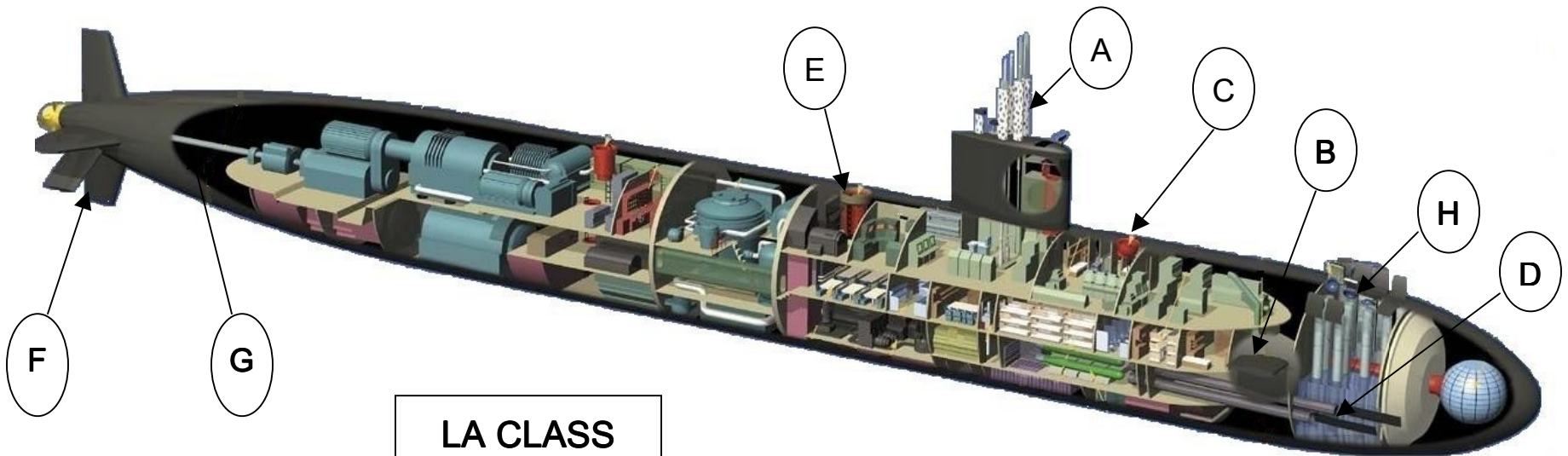

NOTES

KAMATICS

Kamatics is a worldwide supplier of technologically advanced marine, aerospace, hydropower and other industrial products such as:

KAron™ and Katherm™ self-lubricated bearing systems.

Kaflex™ coupling for High Performance power transmission applications.

Reliamet™ Metal to Metal replacement bearing systems.

Fiberlon™ bearings and other Advanced composites for the aerospace wire and other industries qualified to MIL-B-85560.

Kamatics is located at:

1330 Blue Hills Avenue

Bloomfield Connecticut USA 06002-0003

Phone: 860 243-9704