

S-STYLE LEG BEARINGS (ENGLISH)

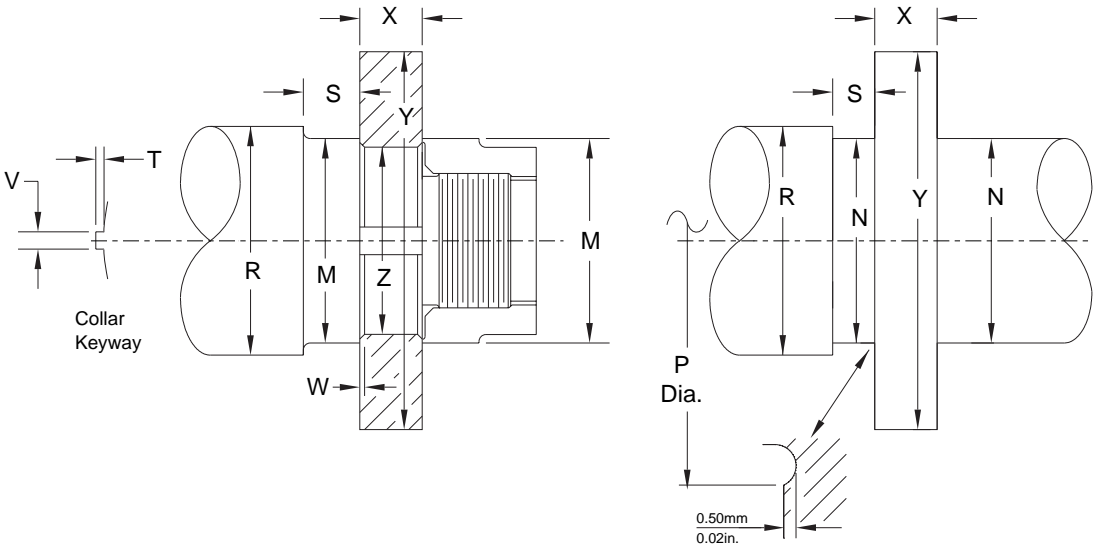

RATED LOAD FOR S-STYLE LEG THRUST BEARINGS

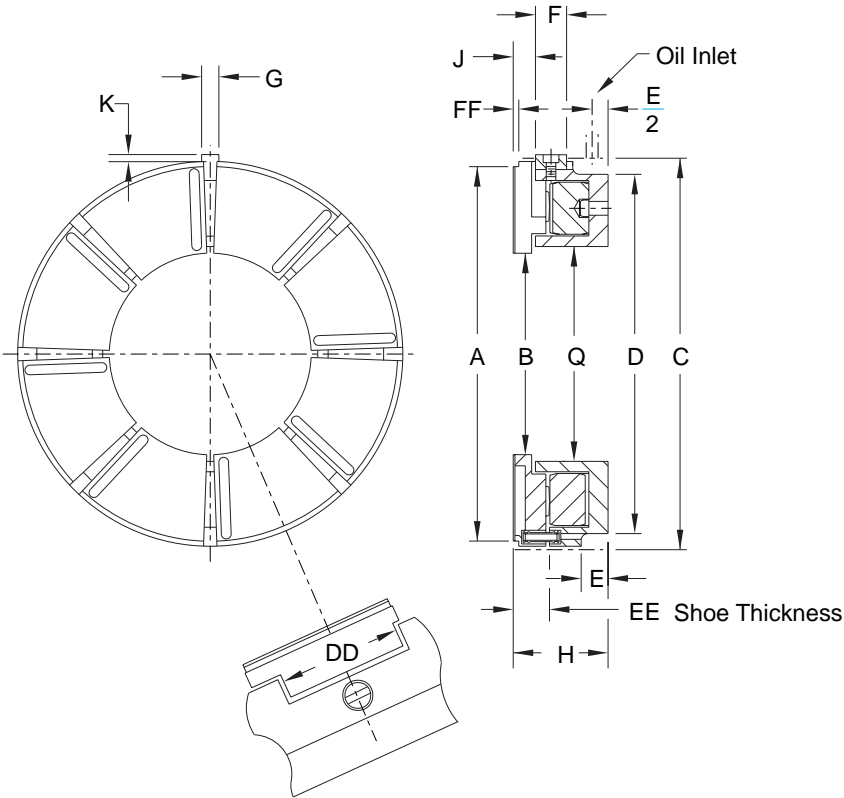
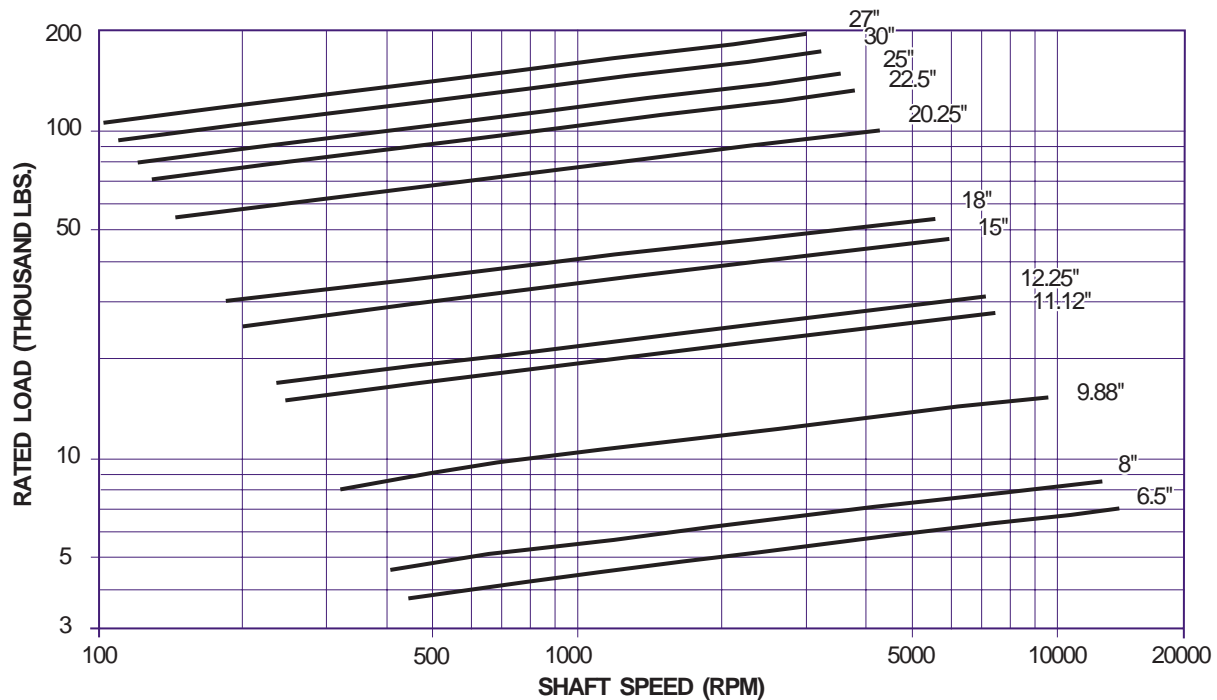

Based on ISO VG 32 supplied at 120°F.

ENGLISH SIZES (Inches)

Brg. Size	6.5	8	9.88	11.12	12.25	15	18	20.25	22.5	25	27	30
No. of Shoes	8	8	12	8	8	10	8	8	8	8	8	12
Area (in ²)	15.3	19.2	30.6	54.1	60.6	82.4	89.0	172.0	217.0	259.0	292.0	271.0
A - Babbitt O.D.	6.50	8.00	9.88	11.12	12.25	15.00	18.00	20.25	22.50	25.00	27.00	30.00
B - Babbitt I.D.	4.06	5.50	7.00	6.50	7.50	9.75	12.25	12.00	13.00	15.00	15.50	20.88
H - Bearing Height	1.56	1.94	1.88	2.75	2.31	2.88	3.50	4.50	5.00	5.50	5.75	5.00
C - Bearing O.D.	6.750	8.375	10.125	11.500	12.625	15.500	18.750	21.000	23.125	26.500	28.000	31.187
Q - Base ring I.D.	4.06	5.50	7.00	6.75	7.62	10.25	12.75	12.75	14.00	15.62	17.25	20.88
D - Oil annulus dia.	6.12	7.81	9.50	10.62	11.56	14.25	17.50	19.50	21.50	24.00	25.25	28.94
E - Oil annulus depth	0.31	0.53	0.50	0.62	0.44	0.69	0.88	1.00	1.25	1.19	1.25	1.58
F - Bearing key, length	0.56	0.75	0.66	0.94	0.50 dia	0.50 dia	1.19	1.38	1.62	2.50	2.12	1.00 dia
G - Bearing key, width	0.31	0.50	0.31	0.44	0.50 dia	0.50 dia	0.56	0.62	0.75	1.12	1.25	1.00 dia
J - Collar to key	0.37	0.44	0.41	0.59	1.06	0.88	0.75	0.93	1.12	1.12	1.31	1.50
K - Key projection	0.16	0.19	0.19	0.19	0.19	0.19	0.22	0.25	0.38	0.50	0.50	0.50
M - Separate shaft dia.	3.88	5.25	6.62	6.12	7.12	9.38	11.88	11.50	12.50	14.50	14.75	20.00
N - Intergral shaft dia.	3.62	5.00	6.38	5.88	6.88	9.00	11.50	11.00	12.00	14.00	14.25	19.50
P - Max dia. over fillet	3.88	5.31	6.81	6.31	7.31	9.56	12.00	11.75	12.62	14.62	15.00	20.38
R - Dia. through base ring	3.88	5.25	6.62	6.38	7.25	9.88	12.38	12.25	13.50	15.12	16.50	20.00
S - Shaft lgth @ shoe I.D.	0.62	0.62	0.75	1.00	1.00	1.00	1.50	1.50	1.75	1.75	2.00	2.00
X - Collar thickness	1.00	1.38	1.50	1.75	2.00	2.00	2.50	3.00	3.25	4.25	4.50	3.75
Y - Collar dia.	6.62	8.12	10.00	11.25	12.38	15.12	18.25	20.50	22.75	25.25	27.25	30.25
Z - Collar bore	3.250	4.500	6.000	5.500	6.500	8.250	10.500	10.250	11.250	13.000	13.500	18.500
T - Collar key depth	0.19	0.31	0.19	0.31	0.38	0.38	0.50	0.50	0.62	0.75	0.75	0.75
V - Collar key width	0.38	0.62	0.38	0.62	0.75	0.75	1.00	1.00	1.25	1.50	1.50	1.50
W - Collar chamfer	0.02	0.06	0.06	0.09	0.09	0.09	0.12	0.12	0.16	0.16	0.16	0.16
DD - Straddle mill	1.47	1.63	1.66	2.78	2.88	2.91	3.56	4.50	4.97	6.22	5.62	4.00
EE - Shoe thickness	0.593	0.687	0.781	1.125	1.125	1.250	1.438	1.750	1.937	2.125	2.375	2.000
FF - Shoe relief	0.06	0.06	0.06	0.06	0.08	0.08	0.06	0.12	0.12	0.19	0.19	0.19
Weight (Lbs) Bearing	9.0	16.0	20.0	48.0	48.0	80.0	130.0	250.0	340.0	500.0	560.0	540.0
Weight (Lbs) Collar	7.5	14.0	21.0	37.0	50.0	71.0	125.0	210.0	285.0	440.0	560.0	480.0
Weight (Lbs) Spare shoes	3.0	4.0	6.0	14.0	16.0	25.0	40.0	75.0	100.0	145.0	180.0	215.0

POWER LOSS: DOUBLE ELEMENT S-STYLE LEG BEARINGS

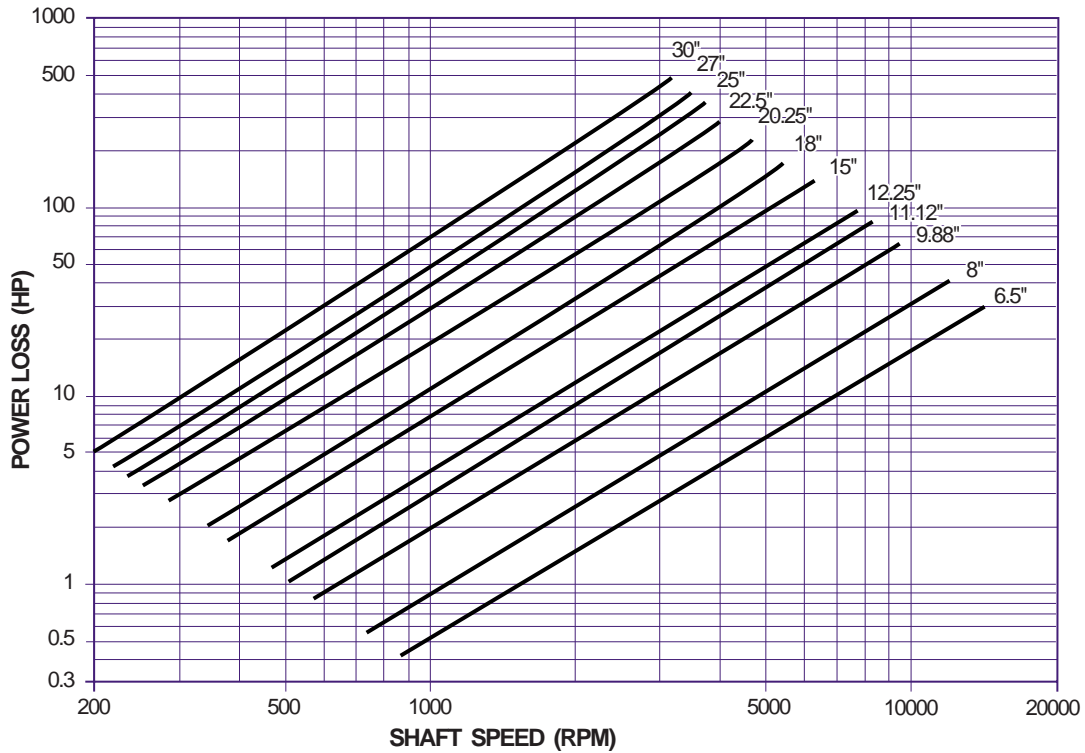

Based on 20% Slack Flow & ISO VG 32 supplied at 120°F

Power loss is based on rated load, recommended oil flow, and Kingsbury's recommended discharge configuration. If any of these is changed the power loss will also change.

OIL SUPPLY FOR S-STYLE LEG BEARINGS

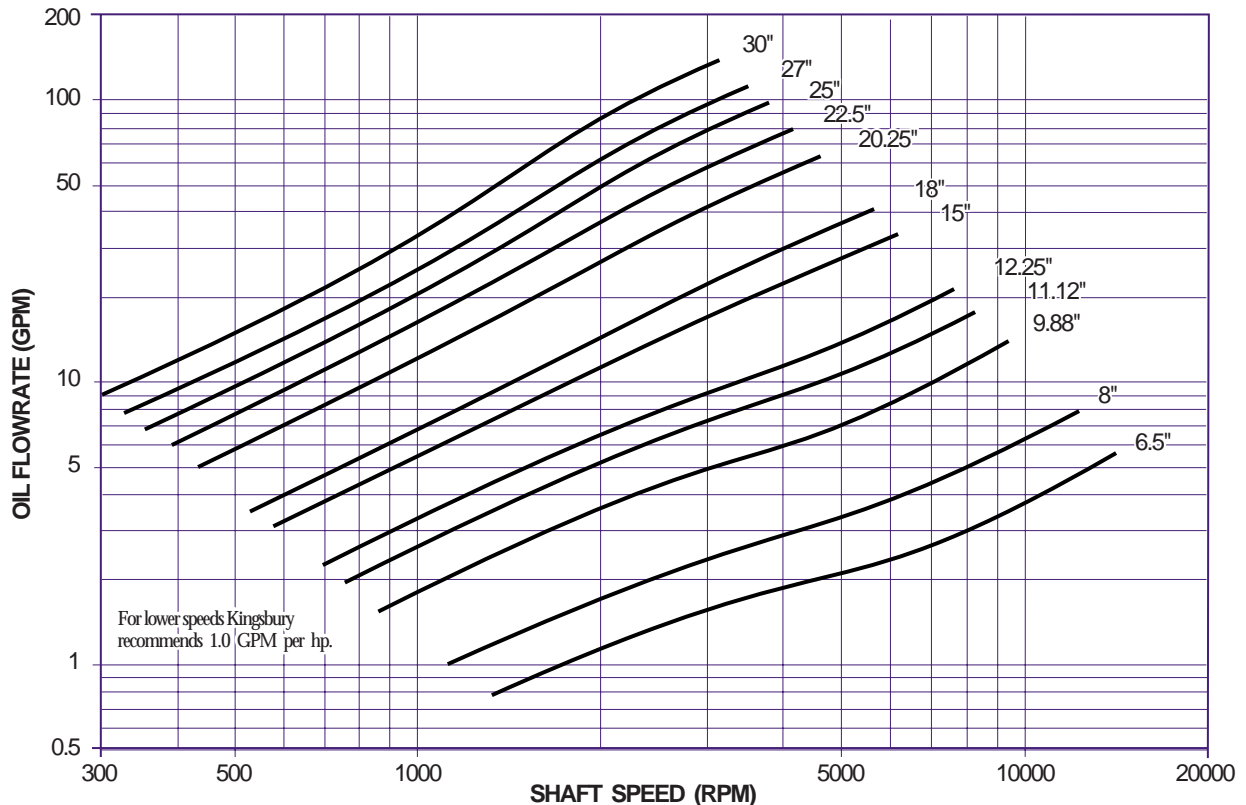

Based On 20% Slack Flow & ISO VG 32 supplied at 120°F

This chart gives loaded side, single element flowrates for rated load. For double element bearings, supply an additional 20% to the inactive side. In machines where load may reverse and apply rated values to either side, provide equal flow to each side (a total of two times the chart value).

75/75 SHOE TEMPERATURE (STEEL)

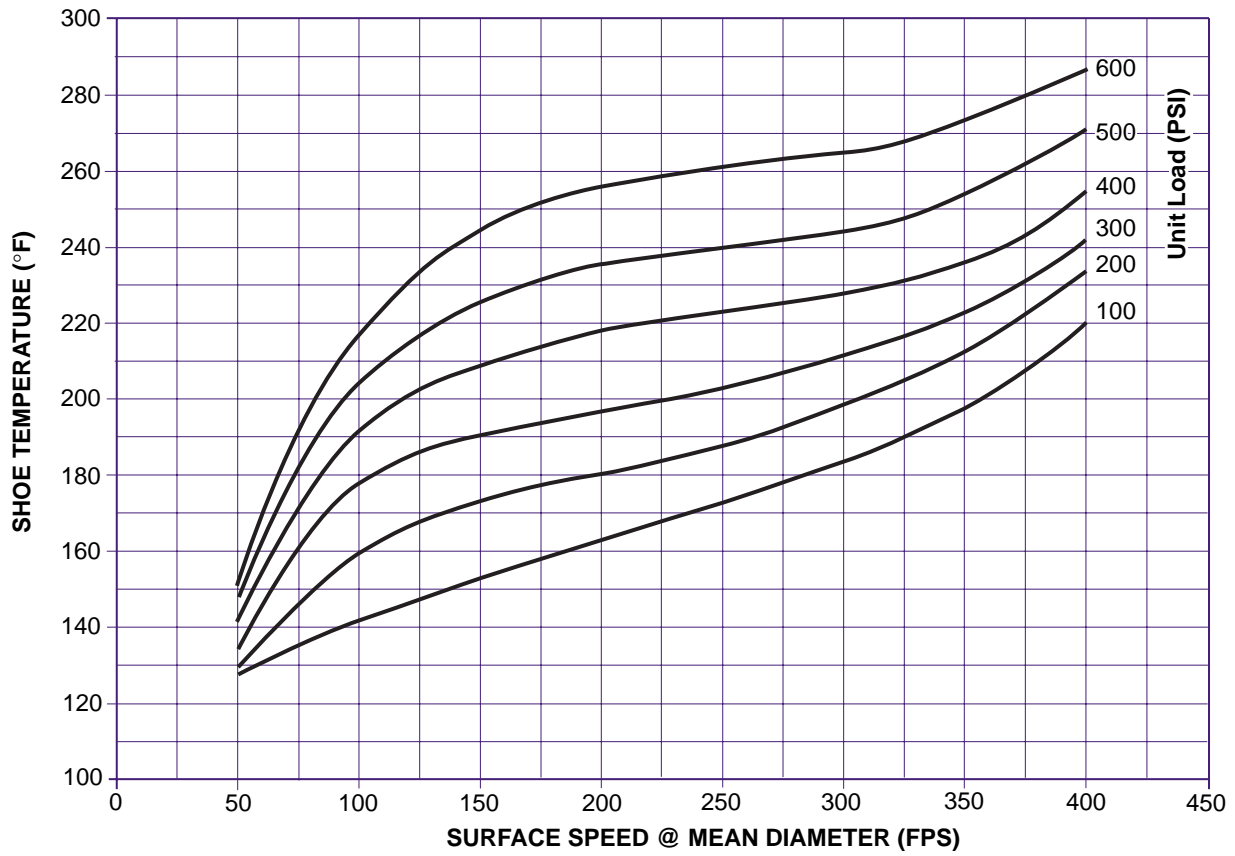

75/75 SHOE TEMPERATURE (CR-CU)

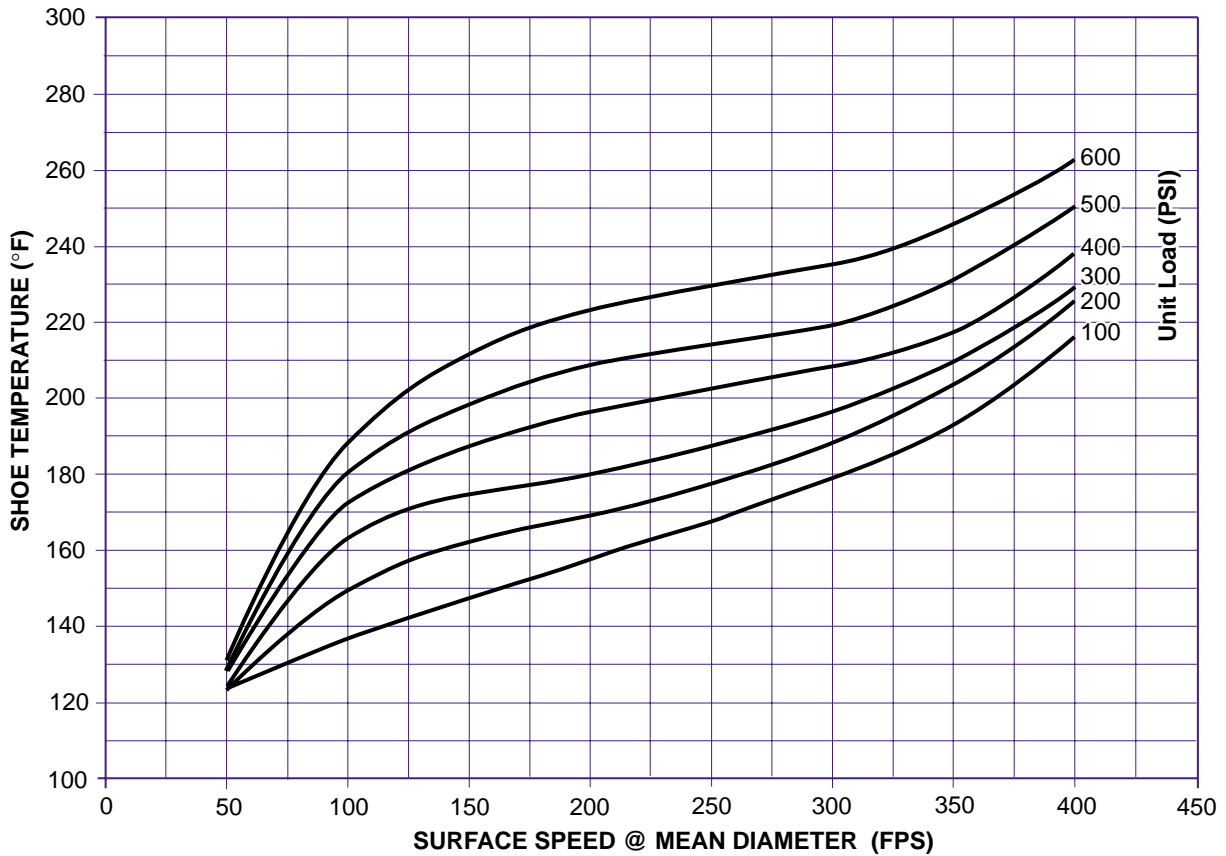

Temperatures are based on recommended oil, flow, and supply temperatures.
Unit load is load divided by bearing area.