

# KOP-FLEX® RESILIENT COUPLINGS

Non-Lubricated - Maintenance-Free - High Torque Capacity - Absorbs Shock Loads

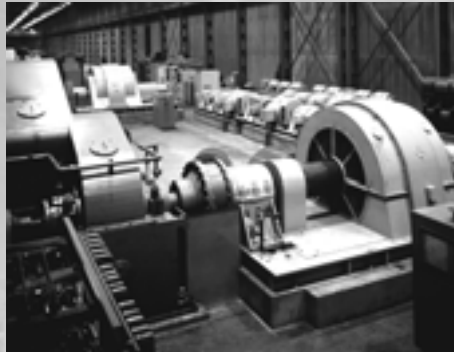

MAX-C K2



MAX-C UB

MAX-C K2 and UB are typically used on:

- Overhead cranes
- Runout/entry/exit tables
- Conveyors
- Fan drives
- Feed rolls
- Pumps



ELASTOMERIC™ Couplings are typically used on:

- Runout /entry/exit tables
- Pumps
- Conveyors

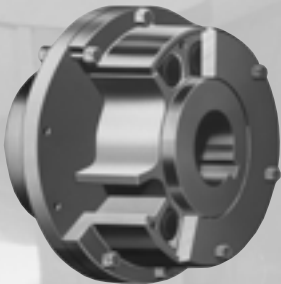

MAX-C

MAX-C Type CB and WB are typically used on:

- Main mill drives
- Crushers
- Main drive
- ID & FD fans
- Drill rigs
- Marine gears
- High torsional load, vibration or stiffness
- Reciprocating engine
- Synchronous motor, variable frequency drive, reversing applications, diesel engines



MAX-C CB

Type CB offers:

- Low torsional stiffness
- Cylindrical block for higher resilience (wind-up)
- Rubber elements with various hardness and durometer are available

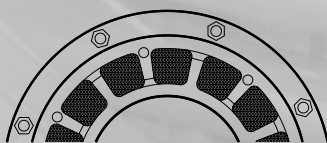

MAX-C WB

Type WB offers:

- High torsional stiffness
- Large torque capacity (up to 56.5 million lbs-in.)
- Rubber block-in-wedge design, with various durometer and hardness
- Special rubber-viton for high temperature or neoprene for special exposure to elements

# MAX-C<sup>®</sup> Resilient Couplings

High Torque,  
Maintenance-Free  
Coupling

---

Absorb Harmful  
Shock Loads

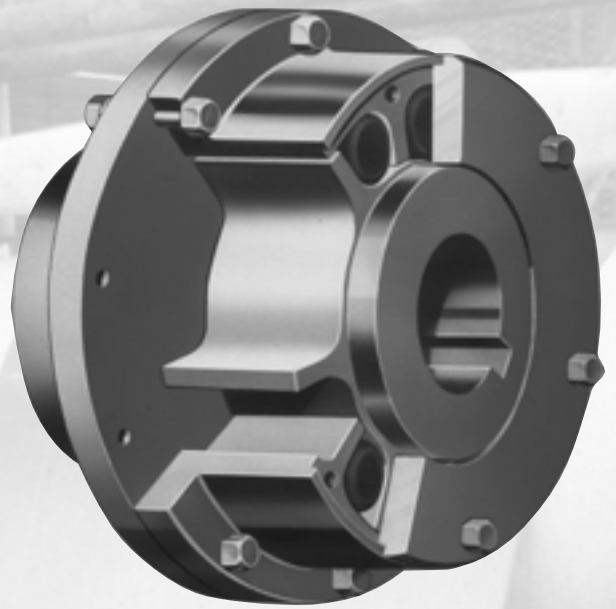

## Index:

|   | Page    |
|---|---------|
| <b>HOW TO ORDER</b> .....                               | 69      |
| Technical Advantages .....                              | 66 - 67 |
| Service Factors .....                                   | 68      |
| Selection Procedure .....                               | 69      |
| Coupling Comments .....                                 | 70 - 71 |
| MAX-C Type K2 .....                                     | 72      |
| MAX-C Type UB .....                                     | 73      |
| Limited End Float Coupling .....                        | 74      |
| Mill Motor Coupling .....                               | 74      |
| Floating Shaft Coupling .....                           | 75      |
| Spacer Coupling .....                                   | 75      |
| MAX-C Type CB & WB<br>For Engineered Applications ..... | 76-80   |



Visit [www.kopflex.com](http://www.kopflex.com)

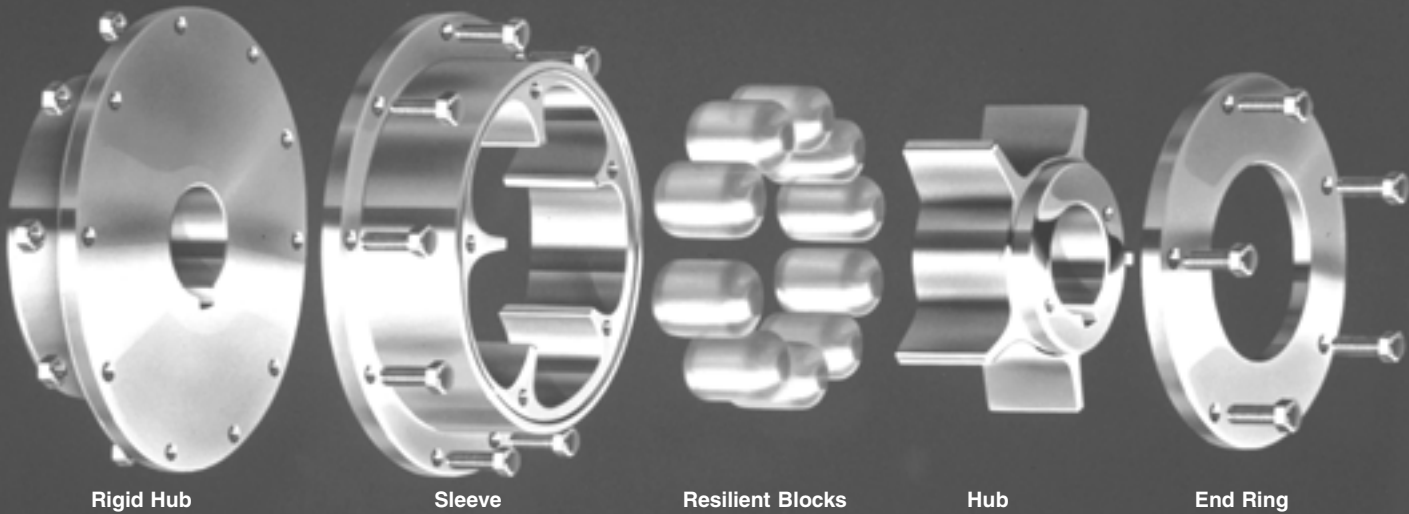

### The MAX-C® Coupling Advantages:

- Transmits very high torque and cushions system shock
- Never needs lubrication
- Easy to assemble and install
- Operates in wet, gritty, hot and other tough conditions
- Can increase drive train and gear component life
- Low maintenance requirements

### Theory of Operation

A flexible coupling must perform two tasks: transmit torque from driving to driven shaft and accommodate shaft misalignments—angular, offset and axial. However, many applications require a third function. These applications involve severe torque fluctuations, starting and stopping of high inertia machinery, shock and impact loading and certain other types of torsional vibration problems characteristic of reciprocating equipment. This third function is to provide the proper degree of resilience and damping.

Resilience is the capacity of the coupling to assume relatively large torsional deflections under torque. That is what the MAX-C® Coupling supplies, a means to attenuate and dampen torsional shock loading and vibration while accommodating misalignment.

### Coupling Design is the Key

MAX-C® Couplings employ three principal components: an outer sleeve, an inner flex hub, both made of metal, and resilient drive blocks. When assembled, the flex hub and sleeve form cavities into which specially designed elastomer blocks are placed. The elastomer blocks are incompressible but the pockets allow block deformation under torque. The cavities are completely filled only under conditions of extreme overload and the coupling thus combines high load carrying capability with resilience. This provides smooth power transmission, day after day, year after year, without ever requiring lubrication.

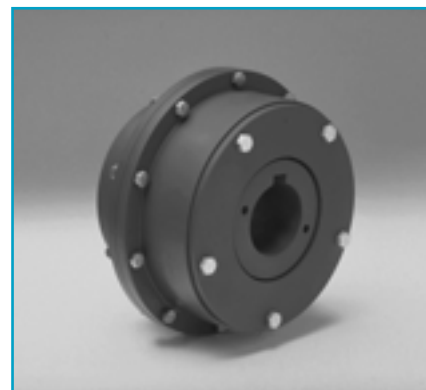

### Superior Service Life

The elastomer block materials (several different block compounds are available) are the key to the MAX-C® Coupling's ability to provide consistent torque transmission with long service life. No other coupling will duplicate its performance and longevity. Block life is long, usually five years or more, but the blocks are easy to replace if useful service life has been reached. Replacing the blocks makes the coupling virtually as good as new.

### Block Material

Type K2 and UB blocks are available in a single compound, MC elastomer, which is specially designed for long life and higher strength than rubber blocks. Maximum operating temperature for MC elastomer blocks is 175° F.

Type WB and CB blocks are supplied in various compounds (natural, nitrile, and SBR high damping rubber) and various hardnesses (40 through 80 Shore 'A' hardness). Since these couplings are designed for engineered applications, the correct block compound and hardness is generally defined by a detailed torsional analysis, or by user experience. Special compounds are also available for specific properties such as high temperature or oil resistant characteristics.

### Fail-Safe Design

The interlocking design of the hub and sleeve blades provide a coupling design that is inherently fail-safe. In the unlikely event that the blocks should suffer a complete failure, the coupling will continue to transmit torque through metal-to-metal contact of the interlocking blades until the equipment can be shut down and the blocks replaced.



### Selection of Coupling Type

The type of MAX-C® Coupling is selected based on the application and any specific requirements (torsional stiffness, damping, etc.) stated by the customer. Each type of coupling has specific torsional properties and should be selected accordingly.

| Prime Mover  |                         | MAX-C® Coupling Type |         |         |
|--|-------------------------|----------------------|---------|---------|
|  |                         | Type K2/UB           | Type CB | Type WB |
| <b>Electric Motors</b>                             | Crane Drives            | ●                    |         | ●       |
|  | Bow Thruster            | ●                    | ●       | ●       |
|  | Pumps                   | ●                    |         |         |
|  | Reduction Gears         | ●                    |         | ●       |
|  | Feed Rolls              | ●                    |         | ●       |
|  | Fans                    | ●                    |         | ●       |
|  | Conveyors               | ●                    |         |         |
|  | Manipulators            | ●                    |         | ●       |
| <b>Synchronous &amp; Variable Frequency Motors</b> | Centrifugal Compressors |                      | ●       | ●       |
|  | Speed Increasers        |                      |         | ●       |
|  | Mill Pinions            |                      |         | ●       |
|  | Kiln Drives             |                      |         | ●       |
|  | Crushers                |                      |         | ●       |
| <b>Diesel Engines</b>                              | ID & FD Fans            |                      |         | ●       |
|  | Generator Sets          |                      | ●       |         |
|  | Fire Pumps              |                      | ●       |         |
|  | Torque Convertors       |                      | ●       |         |
|  | Marine Gears            |                      | ●       | ●       |
|  | Dynamometers            |                      | ●       |         |
|  | Drill Rigs              |                      | ●       | ●       |
|  | Main Propulsion         |                      | ●       | ●       |
| Bow or Stern Thruster                              |                         | ●                    | ●       |         |

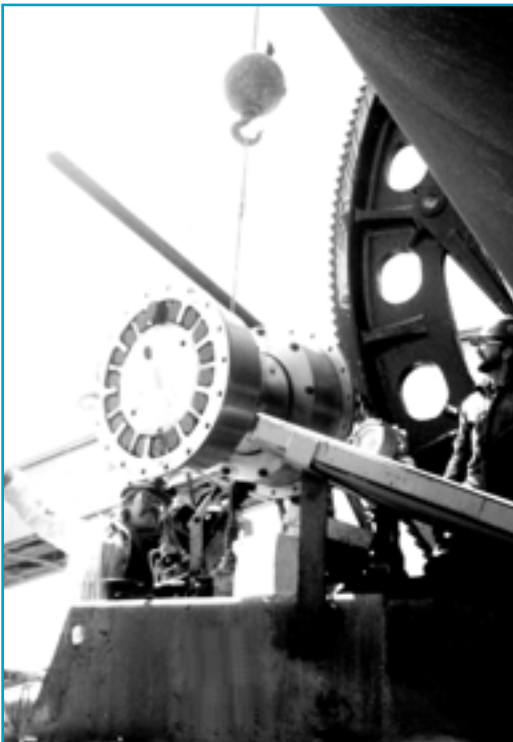

Visit [www.kopflex.com](http://www.kopflex.com)

Values listed are intended only as a general guide, and are typical of usual service requirements. For systems which frequently utilize the peak torque capability of the power source, verify that the magnitude of this peak torque does not exceed the 1.0 Service Factor Rating of the coupling selected. Applications which involve extreme repetitive shock or high-energy load absorption characteristics should be referred — with full particulars — to KOP-FLEX.

Values contained in the table are to be applied to smooth power sources such as electric motors and steam turbines. For drives involving internal combustion engines of four or five cylinders, add 1.0 to the values listed; for six or more cylinders, add 0.5 to the values listed. For systems utilizing AC or DC Mill Motors as the prime mover, refer to Note (1).

**CAUTION** All peoplemoving applications must be referred to engineering.

| Application                                     | Typical Service Factor |
|---|------------------------|
| <b>AGITATORS</b>                                |                        |
| Pure Liquids .....                              | 1.0                    |
| Liquids & Solids .....                          | 1.25                   |
| Liquids — Variable Density .....                | 1.25                   |
| <b>BLOWERS</b>                                  |                        |
| Centrifugal .....                               | 1.0                    |
| Lobe .....                                      | 1.5                    |
| Vane .....                                      | 1.25                   |
| <b>BRIQUETTE MACHINES</b> .....                 | 2.0                    |
| <b>CAR PULLERS</b> — Intermittent Duty .....    | 1.5                    |
| <b>COMPRESSORS</b>                              |                        |
| Centrifugal .....                               | 1.0                    |
| Centriaxial .....                               | 1.25                   |
| Lobe .....                                      | 1.5                    |
| Reciprocating — Multi-Cylinder .....            | 2.0                    |
| <b>CONVEYORS — LIGHT DUTY UNIFORMLY FED</b>     |                        |
| Apron, Bucket, Chain, Flight, Screw .....       | 1.25                   |
| Assembly, Belt .....                            | 1.0                    |
| Oven .....                                      | 1.5                    |
| <b>CONVEYORS — HEAVY DUTY NOT UNIFORMLY FED</b> |                        |
| Apron, Bucket, Chain, Flight, Oven .....        | 1.5                    |
| Assembly, Belt .....                            | 1.25                   |
| Reciprocating, Shaker .....                     | 2.5                    |
| <b>CRANES AND HOISTS (NOTE 1 and 2)</b>         |                        |
| Main hoists, Reversing .....                    | 2.5                    |
| Skip Hoists, Trolley & Bridge Drives .....      | 2.0                    |
| Slope .....                                     | 2.0                    |
| <b>CRUSHERS</b>                                 |                        |
| Ore, Stone .....                                | 3.0                    |
| <b>DREDGES</b>                                  |                        |
| Cable Reels .....                               | 1.75                   |
| Conveyors .....                                 | 1.5                    |
| Cutter Head Jig Drives .....                    | 2.5                    |
| Maneuvering Winches .....                       | 1.75                   |
| Pumps .....                                     | 1.75                   |
| Screen Drives .....                             | 1.75                   |
| Stackers .....                                  | 1.75                   |
| Utility Winches .....                           | 1.5                    |
| <b>ELEVATORS (NOTE 2)</b>                       |                        |
| Bucket .....                                    | 1.75                   |
| Centrifugal & Gravity Discharge .....           | 1.5                    |
| Escalators .....                                | 1.5                    |
| Freight .....                                   | 2.5                    |
| <b>FANS</b>                                     |                        |
| Centrifugal .....                               | 1.0                    |
| Cooling Towers .....                            | 1.5                    |
| Forced Draft .....                              | 1.5                    |
| Induced Draft without Damper Control .....      | 2.0                    |
| <b>FEEDERS</b>                                  |                        |
| Apron, Belt, Disc, Screw .....                  | 1.25                   |
| Reciprocating .....                             | 2.5                    |

| Application                             | Typical Service Factor |
|---|------------------------|
| <b>GENERATORS —</b>                     |                        |
| (Not Welding) .....                     | 1.0                    |
| <b>HAMMER MILLS</b> .....               | 2.0                    |
| <b>LAUNDRY WASHERS —</b>                |                        |
| Reversing .....                         | 2.0                    |
| <b>LAUNDRY TUMBLERS</b> .....           | 2.0                    |
| <b>LINE SHAFT</b> .....                 | 1.5                    |
| <b>LUMBER INDUSTRY</b>                  |                        |
| Barkers — Drum Type .....               | 2.0                    |
| Edger Feed .....                        | 2.0                    |
| Live Rolls .....                        | 2.0                    |
| Log Haul — Incline .....                | 2.0                    |
| Log Haul — Well type .....              | 2.0                    |
| Off Bearing Rolls .....                 | 2.0                    |
| Planer Feed Chains .....                | 1.75                   |
| Planer Floor Chains .....               | 1.75                   |
| Planer Tilting Hoist .....              | 1.75                   |
| Slab Conveyor .....                     | 1.5                    |
| Sorting Table .....                     | 1.5                    |
| Trimmer Feed .....                      | 1.75                   |
| <b>MARINE PROPULSION</b>                |                        |
| Main Drives .....                       | 2.0                    |
| <b>MACHINE TOOLS</b>                    |                        |
| Bending Roll .....                      | 2.0                    |
| Plate Planer .....                      | 1.5                    |
| Punch Press — Gear Driven .....         | 2.0                    |
| Tapping Machines .....                  | 2.5                    |
| Other Machine Tools                     |                        |
| Main Drives .....                       | 1.5                    |
| Auxiliary Drives .....                  | 1.25                   |
| <b>METAL MILLS</b>                      |                        |
| Draw Bench — Carriage .....             | 2.0                    |
| Draw Bench — Main Drive .....           | 2.0                    |
| Forming Machines .....                  | 2.0                    |
| Slitters .....                          | 1.5                    |
| Table Conveyors                         |                        |
| Non-Reversing .....                     | 2.25                   |
| Reversing .....                         | 2.5                    |
| Wire Drawing & Flattening Machine ..... | 2.0                    |
| Wire Winding Machine .....              | 1.75                   |
| <b>METAL ROLLING MILLS (NOTE 1)</b>     |                        |
| Blooming Mills .....                    | *                      |
| Coilers, hot mill .....                 | 2.0                    |
| Coilers, cold mill .....                | 1.25                   |
| Cold Mills .....                        | 2.0                    |
| Cooling Beds .....                      | 1.75                   |
| Door Openers .....                      | 2.0                    |
| Draw Benches .....                      | 2.0                    |
| Edger Drives .....                      | 1.75                   |
| Feed Rolls, Reversing Mills .....       | 3.5                    |
| Furnace Pushers .....                   | 2.5                    |
| Hot Mills .....                         | 3.0                    |
| Ingot Cars .....                        | 2.5                    |
| Kick-outs .....                         | 2.5                    |
| Manipulators .....                      | 3.0                    |
| Merchant Mills .....                    | 3.0                    |
| Piercers .....                          | 3.0                    |
| Pusher Rams .....                       | 2.5                    |
| Reel Drives .....                       | 1.75                   |
| Reel Drums .....                        | 2.0                    |
| Reelers .....                           | 3.0                    |
| Rod and Bar Mills .....                 | 1.5                    |
| Roughing Mill Delivery Table .....      | 3.0                    |
| Runout Tables                           |                        |
| Reversing .....                         | 3.0                    |
| Non-Reversing .....                     | 2.0                    |
| Saws, hot & cold .....                  | 2.5                    |
| Screwdown Drives .....                  | 3.0                    |
| Skelp Mills .....                       | 3.0                    |
| Slitters .....                          | 3.0                    |
| Slabbing Mills .....                    | 3.0                    |
| Soaking Pit Cover Drives .....          | 3.0                    |
| Straighteners .....                     | 2.5                    |
| Tables, transfer & runout .....         | 2.0                    |
| Thrust Block .....                      | 3.0                    |
| Traction Drive .....                    | 3.0                    |
| Tube Conveyor Rolls .....               | 2.5                    |
| Unscramblers .....                      | 2.5                    |
| Wire Drawing .....                      | 1.5                    |
| <b>MILLS, ROTARY TYPE</b>               |                        |
| Ball .....                              | 2.25                   |
| Dryers & Coolers .....                  | 2.0                    |
| Hammer .....                            | 1.75                   |
| Kilns .....                             | 2.0                    |

| Application  | Typical Service Factor |
|--|------------------------|
| Pebble & Rod .....                                 | 2.0                    |
| Pug .....  | 1.75                   |
| Tumbling Barrels .....                             | 2.0                    |
| <b>MIXERS</b>                                      |                        |
| Concrete Mixers .....                              | 1.75                   |
| Drum Type .....                                    | 1.5                    |
| <b>OIL INDUSTRY</b>                                |                        |
| Chillers .....                                     | 1.25                   |
| Paraffin Filter Press .....                        | 1.75                   |
| <b>PAPER MILLS</b>                                 |                        |
| Barker Auxiliaries, Hydraulic .....                | 2.0                    |
| Barker, Mechanical .....                           | 2.0                    |
| Barking Drum Spur Gear Only .....                  | 2.25                   |
| Beater & Pulper .....                              | 1.75                   |
| Bleacher .....                                     | 1.0                    |
| Calenders .....                                    | 2.0                    |
| Chippers .....                                     | 2.5                    |
| Coaters .....                                      | 1.0                    |
| Converting Machines, except Cutters, Platers ..... | 1.5                    |
| Couch Roll .....                                   | 1.75                   |
| Cutters, Platers .....                             | 2.0                    |
| Cylinders .....                                    | 1.75                   |
| Disc Refiners .....                                | 1.75                   |
| Dryers .....                                       | 1.75                   |
| Felt Stretcher .....                               | 1.25                   |
| Felt Whipper .....                                 | 2.0                    |
| Jordans .....                                      | 1.75                   |
| Line Shaft .....                                   | 1.5                    |
| Log Haul .....                                     | 2.0                    |
| Pulp Grinder .....                                 | 1.75                   |
| Press Roll .....                                   | 2.0                    |
| Reel .....   | 1.5                    |
| Stock Chests .....                                 | 1.5                    |
| Suction Roll .....                                 | 1.75                   |
| Washers & Thickeners .....                         | 1.5                    |
| Winders .....                                      | 1.5                    |
| <b>PRINTING PRESSES</b> .....                      | 1.5                    |
| <b>PULLERS</b> — Barge Haul .....                  | 2.0                    |
| <b>PUMPS</b>                                       |                        |
| Centrifugal .....                                  | 1.0                    |
| Boiler Feed .....                                  | 1.5                    |
| Reciprocating                                      |                        |
| Single Acting                                      |                        |
| 1 or 2 Cylinders .....                             | 2.25                   |
| 3 or more Cylinders .....                          | 1.75                   |
| Double Acting .....                                | 2.0                    |
| Rotary, Gear, Lobe, Vane .....                     | 1.5                    |
| <b>RUBBER INDUSTRY</b>                             |                        |
| Mixer — Banbury .....                              | 2.5                    |
| Rubber Calendar .....                              | 2.0                    |
| Rubber Mill (2 or more) .....                      | 2.25                   |
| Sheeter .....                                      | 2.0                    |
| Tire Building Machines .....                       | 2.5                    |
| Tire & Tube Press Openers .....                    | 1.0                    |
| Tubers & Strainers .....                           | 2.0                    |
| <b>SCREENS</b>                                     |                        |
| Air Washing .....                                  | 1.0                    |
| Grizzly .....                                      | 2.0                    |
| Rotary — Stone or Gravel .....                     | 1.5                    |
| Traveling Water Intake .....                       | 1.25                   |
| Vibrating .....                                    | 2.5                    |
| <b>SEWAGE DISPOSAL EQUIPMENT</b>                   |                        |
| Bar Screens .....                                  | 1.25                   |
| Chemical Feeders .....                             | 1.25                   |
| Collectors, Circuline or Straightline .....        | 1.25                   |
| Dewatering Screens .....                           | 1.25                   |
| Grit Collectors .....                              | 1.25                   |
| Scum Breakers .....                                | 1.25                   |
| Slow or Rapid Mixers .....                         | 1.25                   |
| Sludge Collectors .....                            | 1.25                   |
| Thickeners .....                                   | 1.25                   |
| Vacuum Filters .....                               | 1.25                   |
| <b>STEERING GEAR</b> .....                         | 1.0                    |
| <b>STOKERS</b> .....                               | 1.0                    |
| <b>WINCH</b> .....                                 | 1.5                    |
| <b>WINDLASS</b> .....                              | 1.75                   |

\* Refer to KOP-FLEX

#### NOTES

- (1) Maximum Torque at the coupling must not exceed Rated Torque of the coupling.
- (2) Check local and industrial safety codes.

1. **Select Coupling Based on Bore Capacity.**  
Select the coupling size that has a maximum bore capacity equal to or larger than the larger of the two shafts. For interference fits larger than AGMA standards, consult KOP-FLEX.
2. **Verify Coupling Size Based on Load Rating.**
  - a. Select appropriate Service Factor from the Table on page 68.
  - b. Calculate required HP / 100 RPM:  

$$\frac{HP \times \text{Service Factor} \times 100}{RPM} = HP / 100 \text{ RPM}$$
  - c. Verify that the selected coupling has a rating greater than or equal to the required HP / 100 RPM.

3. **Check Balance Requirements.**  
Consult the coupling ratings table to help determine if balancing is required. Verify that the maximum operating speed does not exceed the maximum speed rating of the coupling. The maximum speed rating does not consider lateral critical speed considerations for floating shaft applications.

**Note:** Care must be exercised on proper selection of any shaft coupling. The users must assure themselves that the design of the shaft to coupling hub connection is adequate for the duty intended.



MAX-C K2



MAX-C UB

## How To Order

### PART NUMBER EXPLANATION Complete Rough Bore Coupling

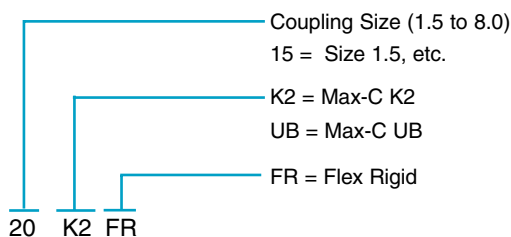

Visit [www.kopflex.com](http://www.kopflex.com)

### Coupling Parts

#### Description

FH = Flex Half  
 RHUB = Rigid Hub  
 BS = Block Set  
 CFFS = Center Flange Fastener Set  
 EFFS = End Ring Fastener Set  
 LEFD = LEF Disk

\* For finish bored hubs, add FB and bore size. Standard bores are supplied with an interference fit per AGMA 9002-A86.

ex: 20 K2 FH FB

### Coupling Comments

Do you have an application that results in frequent gear coupling failure or gearbox damage? Is there excessive vibration present? Is the coupling difficult to maintain and lubricate? If so, the MAX-C® resilient may be the solution!

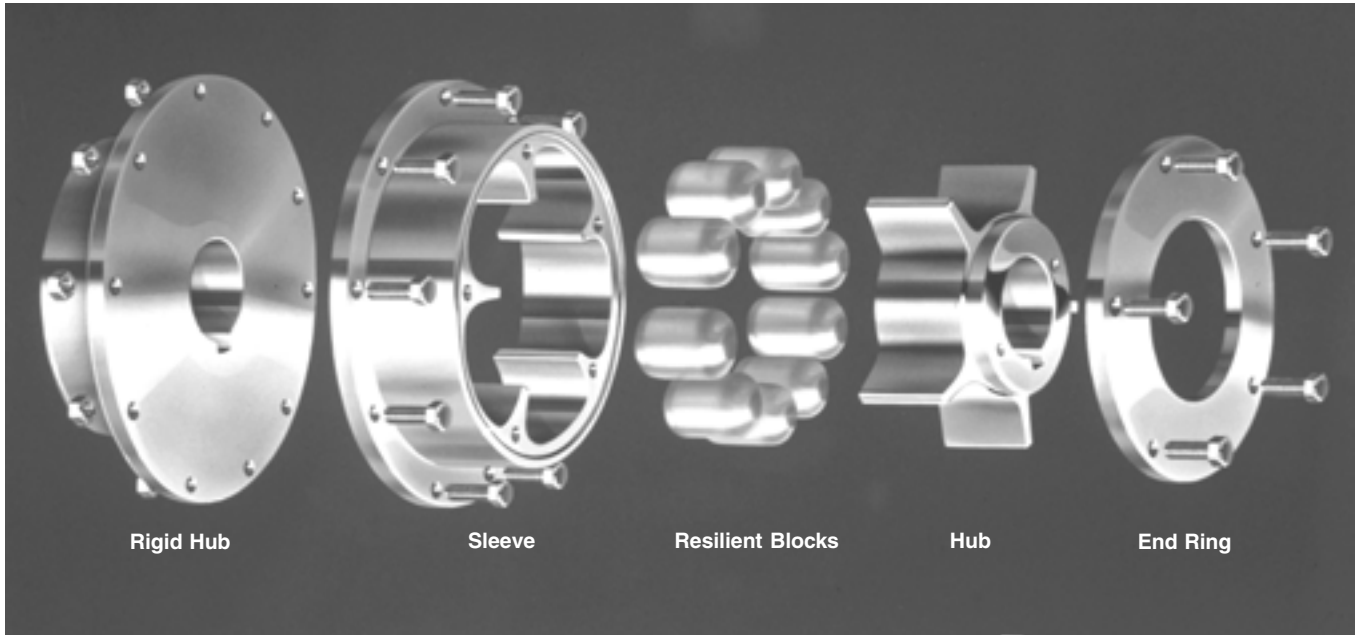

The resilient coupling is a non-lubricated flexible coupling designed to transmit torque via rubber or urethane element under compression, with dampening or cushion. Easy to assemble, operates in rough and gritty environments, and is a fail-safe design – if the blocks wear out the coupling will continue to transmit torque with metal to metal contact temporarily until the blocks can be replaced.

The MAX-C® resilient coupling is available in three styles – K2, WB and CB. Fourth style - UB (urethane cylindrical block design) has been superseded by the K2, but is still available for sale.

**K2:** Urethane wedge shaped blocks. Used on electric motor driving cranes, pumps, feed rolls, fans, conveyors, bow thruster, manipulators, etc. It competes well with RENOLD\* Type 90 and 87 lines along with HI-TEC\*, owned by RENOLD\*.

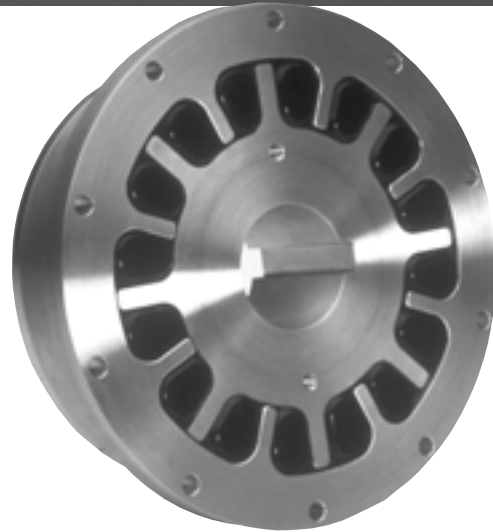

K2 has greater service life, larger torque and bore capacity, and better project or OEM price compared to RENOLD\* or HI-TEC\*. K2 is selected out of the catalog, sold off-the-shelf with rework or finish bored to order.

\*RENOLD, \*HI-TEC and \*HOLSET are trademarks of Renold Public Limited Company. These trade names, trademarks and/or registered trademarks of others are used herein for product comparison purposes only, are the property of their respective owners and are not owned or controlled by Emerson Power Transmission Corporation (EPT). EPT does not represent or warrant the accuracy of this document.

**WB:** Rubber block in wedge shape. The rubber blocks come in various shore hardness and are typically custom-engineered for an application. They are used on synchronous and variable frequency motors driving compressors, kiln drives, steel mill main drives, crushers, ID and FD fans. These come in a wide range of sizes and torque capacity.

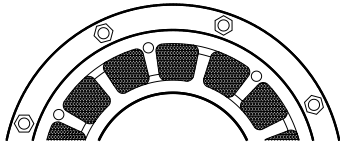

**CB:** Rubber blocks are cylindrical shape. Also available in various hardness, like the WB design. They are primarily used in diesel engines driving generator sets, fire pumps, torque converters, marine drives, drill rigs, main propulsion, etc. They are also available in various sizes and torque ranges, typically custom-engineered.



We are in a unique position to offer a solution coupling which is only available from one competitor in the world - RENOLD\*. However this competitor does not have the product breadth in the resilient type as well as the other coupling products, reputation, technical staff and support available at Emerson Power Transmission.

We also offer MAX-C as a hybrid with other types of couplings like MAX-C with disc, MAX-C with universal joints, or MAX-C with gear coupling. The purpose of the hybrid coupling is to provide the cushion or dampening of the MAX-C, and additional features of the disc or universal joint or gear couplings.

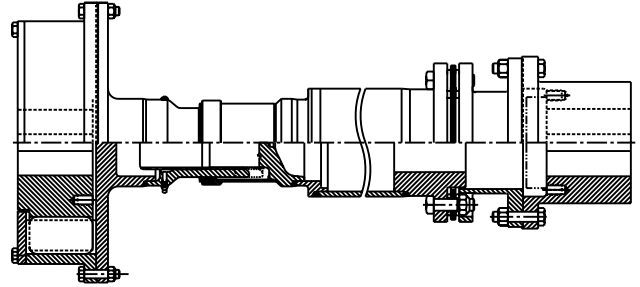

**MAX-C WB with slide disc coupling on tunnel fan application**



**MAX-C on Paddle Wheel Boat**

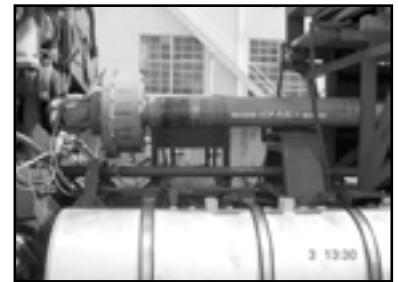

**MAX-C with Universal Joint on Pump for Oil Field**

**Call customer service or coupling Engineering staff at 410-768-1000 or [coupling-engineering@emerson-ept.com](mailto:coupling-engineering@emerson-ept.com) for a solution to your problem applications!**

\*RENOLD is a trademark of Renold Public Limited Company. This trade name, trademark and/or registered trademark is used herein for product comparison purposes only, is the property of its respective owner and is not owned or controlled by Emerson Power Transmission Corporation (EPT). EPT does not represent or warrant the accuracy of this document.



Visit [www.kopflex.com](http://www.kopflex.com)



For high shock and general duty industrial applications where a maintenance-free, non-lubricated coupling is desired. The MAX-C® K2 resilient coupling has high power ratings and a large bore capacity, allowing it to be used in virtually any difficult installation. MAX-C® K2 couplings can also be used as a non-lubricated replacement for many gear couplings in heavy-duty service. For smaller sizes or less demanding service, consider a MAX-C® UB coupling.

The MC elastomer block used in the K2 coupling is specially compounded for high strength, exceeding the capability of normal rubber block couplings. This combination of strength and resilience allows the K2 coupling to be successfully applied to equipment with torque reversals, high momentary torques, start and stop operation and impact and shock loading.

Typical applications include runout tables, conveyors, overhead cranes, fan drives, and any service where shock loading is present. K2 couplings are not meant to be used for reciprocating equipment, synchronous motor or variable frequency motor drives, or where a large amount of torsional displacement is required. For these applications an engineered MAX-C® CB or WB Type coupling should be considered.

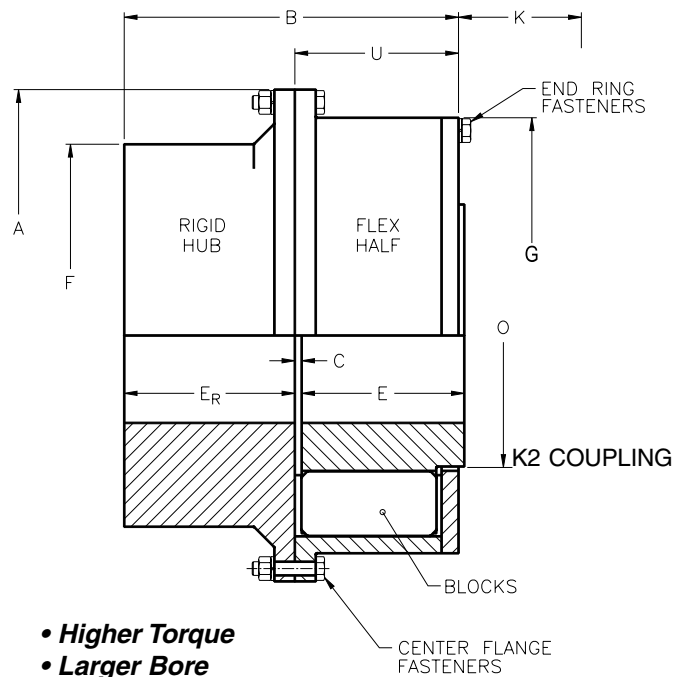

#### MAX-C® K2 COUPLING SPECIFICATIONS

| CPLG SIZE | COUPLING RATINGS (lbs.-in.) |         | MAX. SPEED (RPM) |              | MAX. BORE (in.) |          | DIMENSIONS (INCHES) |       |      |       |      |       |       |       |       |      |
|-----------|-----------------------------|---------|------------------|--------------|-----------------|----------|---------------------|-------|------|-------|------|-------|-------|-------|-------|------|
|           | CONTINUOUS                  | PEAK    | BALANCED         | NOT BALANCED | RIGID (1)       | FLEX HUB | A                   | B     | C    | G     | E    | ER    | F(1)  | K (2) | O     | U    |
| 2.0       | 28400                       | 56800   | 6370             | 4250         | 4.50            | 3.13     | 9.00                | 6.03  | 0.12 | 7.50  | 2.94 | 3.00  | 6.50  | 2.00  | 4.43  | 3.03 |
| 2.5       | 49800                       | 99600   | 5460             | 3640         | 5.25            | 3.75     | 10.50               | 7.13  | 0.12 | 9.00  | 3.38 | 3.62  | 7.50  | 2.50  | 5.29  | 3.51 |
| 3.0       | 73100                       | 146200  | 4770             | 3180         | 6.00            | 4.38     | 12.00               | 8.25  | 0.12 | 10.50 | 3.88 | 4.25  | 8.50  | 2.75  | 6.21  | 4.00 |
| 3.5       | 126000                      | 252000  | 4090             | 2730         | 7.25            | 5.00     | 14.00               | 9.88  | 0.16 | 12.06 | 4.88 | 4.88  | 10.50 | 3.50  | 7.21  | 5.00 |
| 4.0       | 189000                      | 378000  | 3600             | 2400         | 9.63            | 6.00     | 16.00               | 11.12 | 0.19 | 13.94 | 5.38 | 5.62  | 13.50 | 4.00  | 8.36  | 5.50 |
| 4.5       | 265000                      | 530000  | 3180             | 2120         | 9.75            | 6.75     | 18.00               | 12.25 | 0.25 | 15.94 | 5.88 | 6.25  | 14.00 | 4.50  | 9.59  | 6.00 |
| 5.0       | 362000                      | 724000  | 2860             | 1910         | 10.50           | 7.25     | 20.00               | 13.81 | 0.25 | 17.50 | 6.62 | 7.00  | 15.00 | 4.75  | 10.38 | 6.81 |
| 5.5       | 422000                      | 844000  | 2560             | 1710         | 11.88           | 8.25     | 22.63               | 14.37 | 0.25 | 19.88 | 6.38 | 8.00  | 17.00 | 4.63  | 12.13 | 6.37 |
| 6.0       | 630000                      | 1260000 | 2330             | 1550         | 13.38           | 9.25     | 24.88               | 16.38 | 0.25 | 21.62 | 7.88 | 8.50  | 19.00 | 6.00  | 13.13 | 7.88 |
| 7.0       | 819000                      | 1638000 | 2150             | 1430         | 14.13           | 10.00    | 26.88               | 18.12 | 0.50 | 23.12 | 8.88 | 9.25  | 20.00 | 7.13  | 14.13 | 8.87 |
| 8.0       | 1100000                     | 2200000 | 1970             | 1310         | 14.88           | 11.00    | 29.38               | 19.25 | 0.50 | 25.62 | 9.25 | 10.00 | 22.50 | 7.50  | 16.63 | 9.25 |

NOTE 1 - A LARGER RIGID BORE IS AVAILABLE BY INCREASING DIMENSION F - CONSULT KOP-FLEX  
 NOTE 2 - SPACE NEEDED FOR BLOCK REMOVAL.

#### MAX-C® K2 COUPLING PART NUMBERS

| Coupling Size | Complete Coupling |                       | Flex Half |                       | Rigid      |                  | Spare Parts Kits |            |                         |            |                    |            |
|---------------|-------------------|-----------------------|-----------|-----------------------|------------|------------------|------------------|------------|-------------------------|------------|--------------------|------------|
|               | Part No.          | Wt. Solid Hubs (lbs.) | Part No.  | Wt. Solid Hubs (lbs.) | Part No.   | Wt. Solid (lbs.) | Block Set        |            | Center Flange Fasteners |            | End Ring Fasteners |            |
|               |                   |                       |           |                       |            |                  | Part No.         | Wt. (lbs.) | Part No.                | Wt. (lbs.) | Part No.           | Wt. (lbs.) |
| 2.0           | 20 K2 FR          | 66                    | 20 K2 FH  | 31                    | 20 K2 RHUB | 35               | 20 K2 BS         | 1.2        | 20 K2 CFFS              | 1.0        | 20 K2 EFFS         | 0.5        |
| 2.5           | 25 K2 FR          | 100                   | 25 K2 FH  | 44                    | 25 K2 RHUB | 56               | 25 K2 BS         | 2.1        | 25 K2 CFFS              | 1.0        | 25 K2 EFFS         | 0.5        |
| 3.0           | 30 K2 FR          | 160                   | 30 K2 FH  | 76                    | 30 K2 RHUB | 84               | 30 K2 BS         | 3.2        | 30 K2 CFFS              | 1.5        | 30 K2 EFFS         | 0.8        |
| 3.5           | 35 K2 FR          | 260                   | 35 K2 FH  | 120                   | 35 K2 RHUB | 140              | 35 K2 BS         | 5.3        | 35 K2 CFFS              | 1.5        | 35 K2 EFFS         | 1.2        |
| 4.0           | 40 K2 FR          | 420                   | 40 K2 FH  | 180                   | 40 K2 RHUB | 240              | 40 K2 BS         | 8.0        | 40 K2 CFFS              | 1.5        | 40 K2 EFFS         | 1.2        |
| 4.5           | 45 K2 FR          | 550                   | 45 K2 FH  | 250                   | 45 K2 RHUB | 300              | 45 K2 BS         | 11         | 45 K2 CFFS              | 3.0        | 45 K2 EFFS         | 2.0        |
| 5.0           | 50 K2 FR          | 750                   | 50 K2 FH  | 350                   | 50 K2 RHUB | 400              | 50 K2 BS         | 15         | 50 K2 CFFS              | 5.0        | 50 K2 EFFS         | 2.0        |
| 5.5           | 55 K2 FR          | 990                   | 55 K2 FH  | 420                   | 55 K2 RHUB | 570              | 55 K2 BS         | 18         | 55 K2 CFFS              | 5.0        | 55 K2 EFFS         | 4.5        |
| 6.0           | 60 K2 FR          | 1400                  | 60 K2 FH  | 640                   | 60 K2 RHUB | 760              | 60 K2 BS         | 26         | 60 K2 CFFS              | 7.5        | 60 K2 EFFS         | 4.5        |
| 7.0           | 70 K2 FR          | 1700                  | 70 K2 FH  | 780                   | 70 K2 RHUB | 920              | 70 K2 BS         | 36         | 70 K2 CFFS              | 9.0        | 70 K2 EFFS         | 6.0        |
| 8.0           | 80 K2 FR          | 2200                  | 80 K2 FH  | 1000                  | 80 K2 RHUB | 1200             | 80 K2 BS         | 43         | 80 K2 CFFS              | 10.5       | 80 K2 EFFS         | 6.0        |

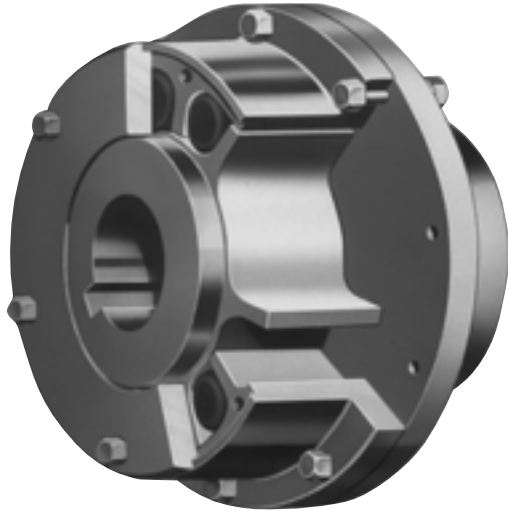

UB COUPLING

For general duty industrial applications where a maintenance-free, non-lubricated coupling is desired. The MAX-C® UB resilient coupling has high power ratings, allowing it to be used in tough applications. MAX-C® UB couplings are available in smaller size ranges for most general duty service, for larger sizes or higher power capacity, consider a MAX-C® K2 coupling.

The MC elastomer block used in the UB coupling is specially compounded for high strength, exceeding the capability of normal rubber block couplings. This combination of strength and resilience allows the UB coupling to be successfully applied to equipment with torque reversals, high momentary torques, start and stop operation and impact and shock loading.

Typical applications include runout tables, conveyors, overhead cranes, fan drives, and any service where shock loading is present. UB couplings are not meant to be used for reciprocating equipment, synchronous motor or variable frequency motor drives, or where a large amount of torsional displacement is required. For these applications an engineered MAX-C® CB or WB Type coupling should be considered.

#### MAX-C® UB COUPLING SPECIFICATIONS

| CPLG SIZE | COUPLING RATING (lbs.-in.) |        | MAX. SPEED (RPM) |              | MAX. BORE (in.) |          | DIMENSIONS (INCHES) |       |      |       |      |                |       |       |       |      |
|-----------|----------------------------|--------|------------------|--------------|-----------------|----------|---------------------|-------|------|-------|------|----------------|-------|-------|-------|------|
|           | CONTINUOUS                 | PEAK   | BALANCED         | NOT BALANCED | RIGID (1)       | FLEX HUB | A                   | B     | C    | G     | E    | E <sub>R</sub> | F(1)  | K(2)  | O     | U    |
| 1.5       | 4400                       | 8800   | 6900             | 4600         | 2.62            | 1.75     | 6.62                | 4.41  | 0.09 | 5.00  | 2.16 | 2.16           | 4.75  | 2.75  | 2.62  | 2.25 |
| 2.0       | 7600                       | 15200  | 5900             | 3930         | 3.12            | 2.12     | 7.75                | 4.91  | 0.09 | 6.12  | 2.41 | 2.41           | 5.75  | 3.00  | 3.22  | 2.50 |
| 2.5       | 13900                      | 27800  | 4800             | 3200         | 3.88            | 2.62     | 9.50                | 5.38  | 0.12 | 7.88  | 2.62 | 2.62           | 6.75  | 3.25  | 3.97  | 2.75 |
| 3.0       | 25200                      | 50400  | 4100             | 2730         | 4.75            | 3.19     | 11.12               | 6.62  | 0.12 | 9.50  | 3.25 | 3.25           | 7.75  | 4.25  | 4.88  | 3.38 |
| 3.5       | 44100                      | 88200  | 3600             | 2400         | 5.75            | 3.81     | 13.25               | 7.88  | 0.12 | 11.25 | 3.88 | 3.88           | 10.12 | 4.75  | 5.88  | 4.00 |
| 4.0       | 75600                      | 151200 | 3000             | 2000         | 5.00            | 4.62     | 15.75               | 9.25  | 0.12 | 13.62 | 4.56 | 4.56           | 8.00  | 5.75  | 7.19  | 4.69 |
| 5.0       | 135500                     | 271000 | 2400             | 1600         | 6.25            | 5.62     | 19.12               | 11.31 | 0.12 | 16.50 | 5.62 | 5.56           | 10.00 | 7.25  | 8.78  | 5.75 |
| 6.0       | 252100                     | 504200 | 1950             | 1300         | 7.50            | 6.88     | 23.50               | 13.12 | 0.19 | 20.25 | 6.81 | 6.12           | 12.00 | 8.75  | 10.62 | 7.00 |
| 7.0       | 378000                     | 756000 | 1760             | 1170         | 8.75            | 7.81     | 26.12               | 15.94 | 0.19 | 22.88 | 7.88 | 7.88           | 14.00 | 10.25 | 12.12 | 8.06 |

NOTE 1 - A LARGER RIGID BORE IS AVAILABLE BY INCREASING DIMENSION F - CONSULT KOP-FLEX

NOTE 2 - SPACE NEEDED FOR BLOCK REMOVAL.

#### MAX-C® UB COUPLING PART NUMBERS

| Coupling Size | Complete Coupling |                       | Flex Half |                       | Rigid      |                  | Spare Parts Kits |            |                         |            |                    |            |
|---------------|-------------------|-----------------------|-----------|-----------------------|------------|------------------|------------------|------------|-------------------------|------------|--------------------|------------|
|               | Part No.          | Wt. Solid Hubs (lbs.) | Part No.  | Wt. Solid Hubs (lbs.) | Part No.   | Wt. Solid (lbs.) | Block Set        |            | Center Flange Fasteners |            | End Ring Fasteners |            |
|               |                   |                       |           |                       |            |                  | Part No.         | Wt. (lbs.) | Part No.                | Wt. (lbs.) | Part No.           | Wt. (lbs.) |
| 1.5           | 15 UB FR          | 25                    | 15 UB FH  | 11                    | 15 UB RHUB | 14               | 15 UB BS         | 0.4        | 15 UB CFFS              | 0.8        | 15 UB EFFS         | 0.4        |
| 2.0           | 20 UB FR          | 40                    | 20 UB FH  | 18                    | 20 UB RHUB | 22               | 20 UB BS         | 0.8        | 20 UB CFFS              | 0.8        | 20 UB EFFS         | 0.5        |
| 2.5           | 25 UB FR          | 62                    | 25 UB FH  | 28                    | 25 UB RHUB | 34               | 25 UB BS         | 1.5        | 25 UB CFFS              | 1.0        | 25 UB EFFS         | 0.5        |
| 3.0           | 30 UB FR          | 104                   | 30 UB FH  | 50                    | 30 UB RHUB | 54               | 30 UB BS         | 2.7        | 30 UB CFFS              | 1.0        | 30 UB EFFS         | 0.5        |
| 3.5           | 35 UB FR          | 180                   | 35 UB FH  | 80                    | 35 UB RHUB | 100              | 35 UB BS         | 4.5        | 35 UB CFFS              | 1.5        | 35 UB EFFS         | 0.7        |
| 4.0           | 40 UB FR          | 280                   | 40 UB FH  | 140                   | 40 UB RHUB | 140              | 40 UB BS         | 8.1        | 40 UB CFFS              | 1.5        | 40 UB EFFS         | 1.0        |
| 5.0           | 50 UB FR          | 420                   | 50 UB FH  | 220                   | 50 UB RHUB | 200              | 50 UB BS         | 14         | 50 UB CFFS              | 3.0        | 50 UB EFFS         | 1.4        |
| 6.0           | 60 UB FR          | 740                   | 60 UB FH  | 450                   | 60 UB RHUB | 290              | 60 UB BS         | 25         | 60 UB CFFS              | 5.5        | 60 UB EFFS         | 3.0        |
| 7.0           | 70 UB FR          | 1030                  | 70 UB FH  | 590                   | 70 UB RHUB | 440              | 70 UB BS         | 38         | 70 UB CFFS              | 6.0        | 70 UB EFFS         | 3.0        |

### Type K2 Limited End Float LEF Coupling

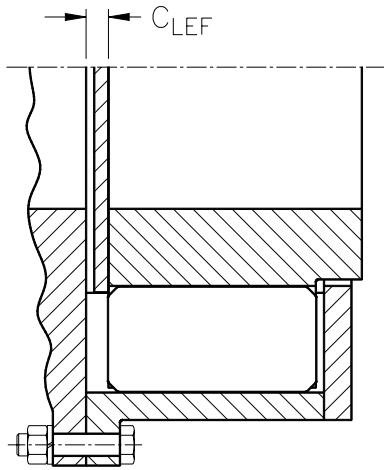

For sleeve bearing motor applications, MAX-C® couplings are supplied with an LEF disc to limit the float of the motor rotor and protect the motor bearings. The shaft separation,  $C_{LEF}$ , is larger than the standard separation in order to accommodate the LEF disc and to limit the float.

| COUPLING SIZE | TOTAL LEF | $C_{LEF}$ | LEF DISC (1) |            |
|---------------|-----------|-----------|--------------|------------|
|               |           |           | Part No.     | Wt. (lbs.) |
| 2.0           | .12       | .19       | 20 K2 LEFD   | 1          |
| 2.5           | .12       | .19       | 25 K2 LEFD   | 1          |
| 3.0           | .12       | .20       | 30 K2 LEFD   | 1          |
| 3.5           | .19       | .21       | 35 K2 LEFD   | 1          |
| 4.0           | .19       | .26       | 40 K2 LEFD   | 2          |
| 4.5           | .19       | .35       | 45 K2 LEFD   | 2          |
| 5.0           | .19       | .38       | 50 K2 LEFD   | 2          |
| 5.5           | .19       | .41       | 55 K2 LEFD   | 2          |
| 6.0           | .19       | .40       | 60 K2 LEFD   | 2          |
| 7.0           | .19       | .66       | 70 K2 LEFD   | 2          |
| 8.0           | .19       | .66       | 80 K2 LEFD   | 3          |

(1) LEF discs are used only in closed coupled applications. One disc is required per coupling.

### Type K2 & UB Mill Motor Coupling

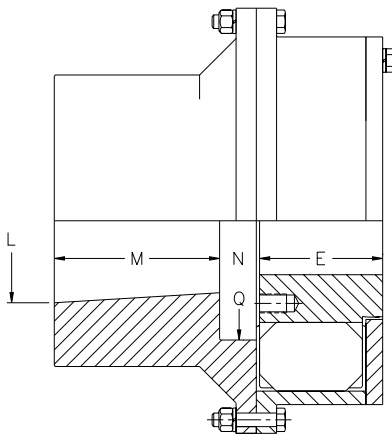

| AISE MILL MOTOR FRAME SIZE | DIMENSIONS (INCHES) |      |      |       | K2 COUPLING |              |   | UB COUPLING |              |   |
|----------------------------|---------------------|------|------|-------|-------------|--------------|---|-------------|--------------|---|
|                            | L                   | M    | N    | Q     | CPLG. SIZE  | WEIGHT (lb.) | WR <sup>2</sup> (lb.-in. <sup>2</sup> ) | CPLG. SIZE  | WEIGHT (lb.) | WR <sup>2</sup> (lb.-in. <sup>2</sup> ) |
| 802, 602, AC1, AC2, AC4    | 1.749               | 3.00 | 0.94 | 2.62  | 2.0         | 41           | 302                                     | 1.5         | 7            | 22                                      |
| 803, 804, 603, 604         | 1.999               | 3.50 | 1.00 | 3.12  | 2.0         | 44           | 327                                     | 2.0         | 15           | 68                                      |
| 806, 606, AC8, AC12        | 2.499               | 4.00 | 1.12 | 3.88  | 2.0         | 46           | 351                                     | 2.5         | 24           | 165                                     |
| 808, 608                   | 2.999               | 4.50 | 1.25 | 4.75  | 2.0         | 46           | 366                                     | 3.0         | 34           | 326                                     |
| 810, 610, AC18             | 3.249               | 4.50 | 1.38 | 5.50  | 2.5         | 65           | 687                                     | 3.5         | 59           | 837                                     |
| 812, 612, AC25, AC30       | 3.623               | 5.00 | 1.50 | 5.50  | 2.5         | 68           | 729                                     | 3.5         | 60           | 862                                     |
| 814, 614, AC40, AC50       | 4.248               | 5.00 | 1.62 | 6.50  | 3.0         | 87           | 1250                                    | 4.0         | 83           | 1670                                    |
| 816, 616                   | 4.623               | 5.50 | 1.75 | 8.50  | 4.0         | 252          | 7040                                    | 5.0         | 154          | 4540                                    |
| 818, 618                   | 4.998               | 6.00 | 1.38 | 8.50  | 4.0         | 256          | 7180                                    | 5.0         | 156          | 4580                                    |
| 620                        | 5.873               | 6.75 | 1.75 | 8.50  | 4.0         | 277          | 8040                                    | 5.0         | 157          | 4710                                    |
| 622                        | 6.247               | 7.25 | 2.38 | 10.00 | 4.5         | 329          | 10900                                   | 6.0         | 271          | 11760                                   |
| 624                        | 6.997               | 9.25 | 2.38 | 10.00 | 4.5         | 378          | 12700                                   | 6.0         | 295          | 12540                                   |

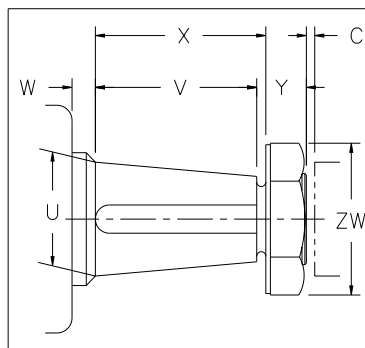

**Tapered Bores**— For Tapered Shafts, with or without locknut, determine applicable AISE Mill Motor frame or give data:

1. U Major Diameter.
2. V Length of tapered portion of shaft.
3. X Length to face of lockwasher.
4. Y Length of threaded projection.
5. ZW Locknut diameter across corners.
6. W Clearance to bearing housing.
7. Taper (inches on diameter per foot of length).
8. Keyway width and depth.
9. Whether keyway is parallel to shaft or to taper.
10. C Shaft separation if machines are in place.

### Type K2 & UB Floating Shaft Coupling

For very long shaft separations, floating shaft couplings are used. With rigids mounted on the equipment shafts, the floating shaft assembly drops out for easy block inspection and replacement. MAX-C halves with special end rings and centering bushings are required.

When ordering, be sure to include HP and RPM, shaft separation and equipment shaft sizes. Applications with very large shaft separations and/or high speeds may require tubular floating shafts due to lateral critical speed considerations.

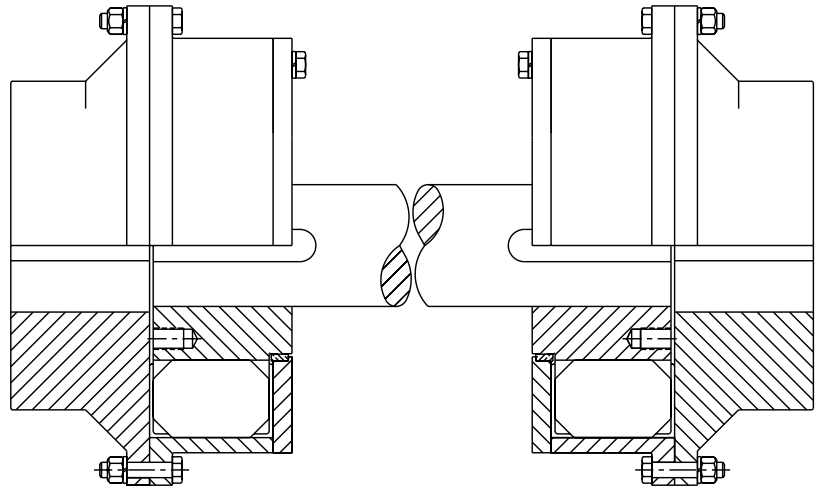

### Type K2 & UB Spacer Coupling

Spacer couplings are used on applications with extended shaft separations. Standard flex halves are typically used with a standard gear coupling rigid and a spacer which is made to order.

For longer separations, and for more misalignment capacity, the rigid half is replaced by a flexible disc or gear coupling half, and a modified MAX-C half with special end ring and centering bushing are used.

For applications with shaft separations slightly larger than standard, a special long rigid can be supplied, counterbored for the correct shaft separation, eliminating the need for a spacer.

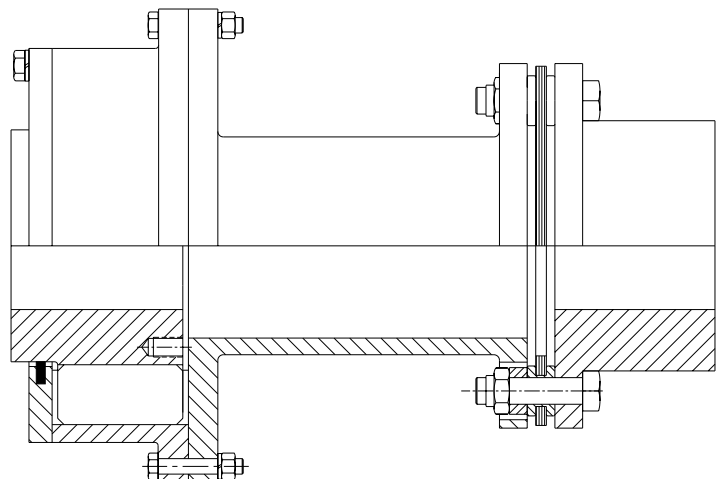
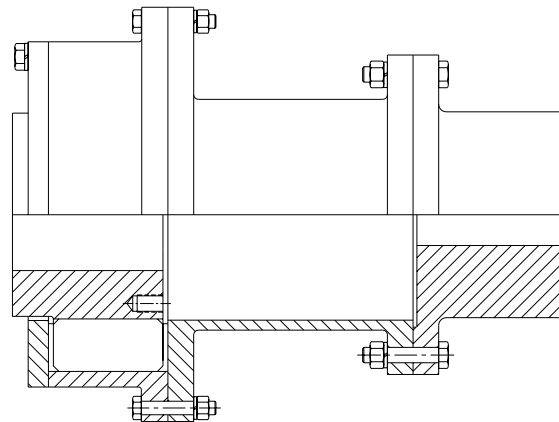

Visit [www.kopflex.com](http://www.kopflex.com)

The MAX-C® Coupling series also includes two specially engineered types, the MAX-C CB and WB, designed for the heavy duty service encountered on applications with reciprocating or severe impact loading. Each coupling type, CB and WB, is available with a wide variety of performance features and options so they can be custom-engineered for each application to solve special problems and provide outstanding operating service.

Contact us with specific information about your application, and an engineered MAX-C® CB or WB coupling can be supplied to suit your particular needs.

**Design Expertise** - from modification of a standard coupling to a completely new design. Couplings can be designed to suit a customer's system - low torsional stiffness, high load capacity, special space envelope, high or low inertia, etc.

New, or alternate, materials can be specified to meet various requirements. Specific rubber compounds can be developed to suit a specific application - e.g. Viton for high temperature applications or Neoprene for continuous exposure to petroleum products.

**Engineering Calculations** - from basic mass elastic data to a system torsional analysis. Other calculations routinely performed include hub/shaft torque capacity, frequency (lateral, axial, etc.) calculations and component stress analysis.

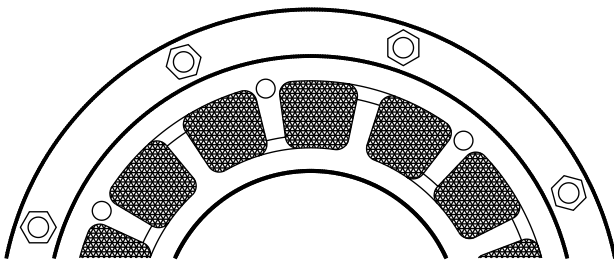
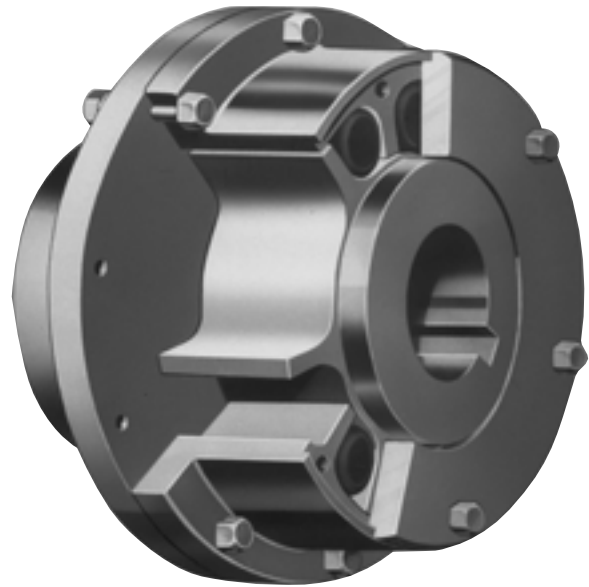

#### TYPE WB

The MAX-C Type WB should be specified for severe impact or reversing conditions where use of a coupling with moderately high degree of torsional stiffness (a lower degree of angular displacement, varying from 1° to 2° or more) to provide high shock absorbing capacity is required. The high torques at the moment of impact, as well as their possible amplifications at other locations in the drive, usually dictate the use of the Wedge Block MAX-C. The block tends to fill the cavity and the larger driving areas of contact between block and blade will support severe overloads.

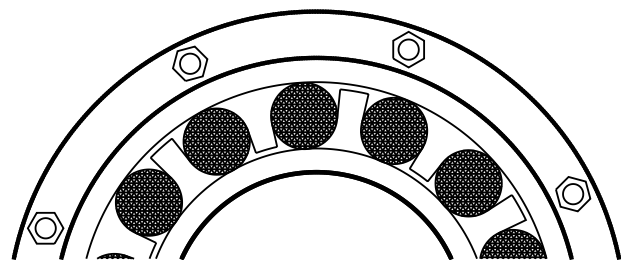

#### TYPE CB

The MAX-C Type CB should be used when resonant vibration conditions, inherent in reciprocating drives, dictate the use of a coupling with very low torsional stiffness (or high degree of angular displacement, approaching 6° or 7° at peak torque), permitting a large windup in relation to the vibratory torque. In the Cylindrical Block MAX-C, there is more space in the cavity or pocket into which the block may deflect under load, producing the high resiliency desired. Even greater resiliency or windup, approaching 14°, can often be achieved with the Type CB to meet specific applications merely by assembling two couplings in tandem.



Visit [www.kopflex.com](http://www.kopflex.com)

### Selection Procedure - Type CB & WB

#### MAX-C® COUPLING TYPE CB AND WB SIZING AND SELECTION

The use of type CB or WB will usually be determined by one or more of the following criteria:

1. If a torsional analysis of the system is made, the analysis will indicate whether to use type WB or CB, the rubber block hardness and compound, and where the coupling should be located in the drive.
2. If a system torsional analysis is not going to be made, follow the guidelines given below:
  - a. Diesel Engine Drives: Consult Engineering.
  - b. Electric Motor Drives: If there is a direct drive (no gearing) and the electric motor is the source of torsional shock or vibration, use a WB coupling mounted on the motor shaft and driven shaft. If a CB coupling is more readily available, it can be used.
  - c. Speed Reducer: If there is a speed reducer involved and the source of torsional shock or vibration is from the driven machine, then usually a WB coupling should be mounted in the low speed shafting. If the drive arrangement precludes this, use a CB coupling in the high speed (motor) shafting.
  - d. Speed Increaser: If there is a speed increaser involved and the source of torsional shock or vibration is from the high speed machine, use a WB coupling in the high speed shafting or, if this is not possible, use a CB in the low speed (motor) shafting.
3. The choice of rubber block hardness and compound is determined from experience. General guidelines are:
  - Steel Mill Drives - natural or nitrile rubber, 60 durometer.
  - Grinding Mills, Ball Mills - Nitrile or high damping rubber, 60 or 70 durometer.
  - Synchronous Motors & AC Variable Frequency Motors - high damping rubber, 60 or 70 durometer.
  - Diesel Engine Drives - natural rubber, 50 or 60 durometer.

#### Determine Coupling Size

There are two basic methods for selection of proper coupling size:

##### Method 1

When application PEAK, CONTINUOUS, AND VIBRATORY TORQUE LEVELS ARE KNOWN based on a system torsional analysis, select the smallest MAX-C type CB or WB, that has peak, continuous, and vibratory torque capacities exceeding those of the application.

##### Method 2

When application torques are NOT KNOWN, service factors must be used to make a selection. (If application peak, continuous and vibratory torques are established later, the selection based on method 2 should be confirmed by method 1).

- a) Determine PRIME MOVER FACTOR from Table on Page 80.
- b) Determine DRIVEN MACHINE FACTOR from Table on Page 80.
- c) Add these two factors together to obtain the TOTAL SYSTEM FACTOR.

**NOTE:** For CB couplings, the total system service factor must be at least 3.0.

- d) Calculate the requirement of the application load in HP per 100 RPM as follows:

$$\text{HP}/100 \text{ RPM} = \frac{\text{Normal continuous HP} \times 100 \times \text{Total System Factor (TSF)}}{\text{RPM}}$$

- e) Refer to peak ratings for the type of MAX-C® coupling selected from Tables 1 or 2 and select a coupling sized equal to or larger than the calculated requirements.

**Selection Example:** A centrifugal compressor is driven by a 2,270 HP synchronous motor at 1800 RPM.

Prime Mover Factor = 1

Driven Machine Factor = 2

For a Total System Factor (TSF) of 3.0

$$\frac{2,270 \text{ (HP)} \times 100 \times 3.0 \text{ (TSF)}}{1,800}$$

Therefore: HP/100 RPM = 378.33

The application requires a coupling with a rating of at least 378.33 HP/100 RPM. Since a type WB is suggested for a Synchronous motor drive, a size 5 1/2 WB rated at 530 HP/RPM is the correct choice.

#### Bore Capacity

Note the bore or shaft requirements of the application and compare to the maximum bore columns on pages 78 or 79 to confirm coupling size selection. Increase the coupling size if its bores are too small for the application.

#### Operating Speed & Balancing Requirements

The maximum operating speeds for the selected coupling must not exceed speeds shown in the tables. Type CB couplings Sizes 1 1/2 through 4 will require component balancing when operating speeds exceed:

Consideration must be given to dynamically balancing all Type WB couplings and Size 5 or larger MAX-C® Type CB couplings when operating speeds exceed 2/3 of the catalog maximum speed, shown in Tables 1 & 2.

#### Limited End Float

Type WB and CB couplings can be furnished to limited end float (L.E.F) requirements. Limited end float is usually required when the electric motor is of the sleeve bearing type and is furnished as standard by KOP-FLEX for electric motors rated at 500 HP and higher.

#### Spacer Type & Floating Shaft Couplings

For accurate and concentric location of the flex hubs and floating member at certain operating speeds, centering bushings may be required. Please contact KOP-FLEX for details. Maximum allowable misalignment for Floating shaft and Spacer couplings, at speeds up to 500 RPM, is 1/2° at each end.

For speeds above 500 RPM calculate the limits of misalignment as follows:

$$\text{Misalignment limit} = 1/2^\circ \times \sqrt{\frac{500}{\text{Operating RPM}}}$$

If more information or assistance is needed to select a MAX-C® coupling please contact KOP-FLEX.

#### Rubber Block Life

The rubber drive block operating life should be at least five years...provided the coupling is selected, installed and operated (in terms of steady torque, peak torque, vibratory torque and misalignment) in accordance with criteria stated by KOP-FLEX.

#### Coupling Damping

Coupling damping is provided by the Type CB & WB couplings through the high energy absorption characteristics of the elastomer drive blocks. The Type SBR compound is suggested when large amounts of damping are required.

The amount of damping provided by the coupling can be calculated by the following formula:

$$C = \frac{K}{Mw} \quad \text{where } C = \text{Coupling Specific Damping .... lb. in. sec./rad.}$$

$$\text{where } K = \text{Coupling torsional stiffness ..... lb. in./rad.}$$

$$\text{where } w = \text{Torsional vibration frequency ..... rad./sec.}$$

$$\text{where } M = \text{Coupling dynamic magnifier non-dimensional}$$

Coupling dynamic magnifiers relative to rubber compound and durometer are as follows:

| Natural Rubber<br>(Typical application - Diesel Drives) |                   | Nitrile<br>(Typical application - Grinding Mill Drives) |                   | SBR High Damping<br>(Typical application - Synchronous Motor Drives) |                   |
|---|-------------------|---|-------------------|--|-------------------|
| Shore Hardness  | Dynamic Magnifier | Shore Hardness  | Dynamic Magnifier | Shore Hardness   | Dynamic Magnifier |
| 50  | 12                | 50  | 10                | 50   | 4                 |
| 60  | 9                 | 60  | 7                 | 60   | 3.5               |
| 70  | 7                 | 70  | 5.5               | 70   | 3                 |
| 80  | 5                 | 80  | 4.5               | 80   | 3                 |

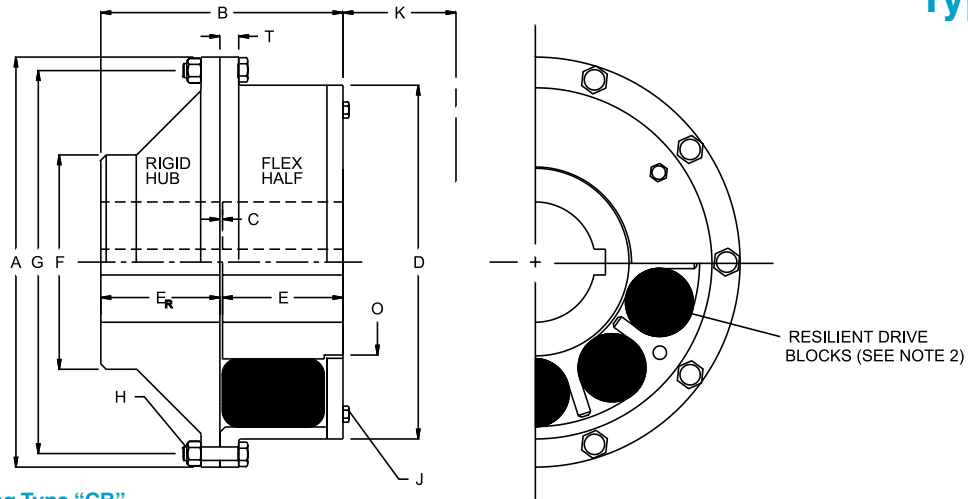

**Table 1 MAX-C® Coupling Type “CB”**

| Coupling Size | ④ Max. Bore of Flex Hub (in.) | Peak Capacity (HP/100 RPM) | Peak Torque (lb.-in. x 10 <sup>-3</sup> ) | ③ Vibratory Torque (lb.-in. x 10 <sup>-3</sup> ) | ⑥ Max. Speed (RPM) | Number of Cavities | ② Number of Block | DIMENSIONS (INCHES) |          |      |        |          |                |        |        |        |          |        | Bolts - No. & Dia. (in) | Bolts - No. & Dia. (in) |
|---------------|-------------------------------|----------------------------|---|--|--------------------|--------------------|-------------------|---------------------|----------|------|--------|----------|----------------|--------|--------|--------|----------|--------|-------------------------|-------------------------|
|               |                               |                            |   |  |                    |                    |                   | A                   | B        | C    | D      | E        | F <sub>R</sub> | F      | G      | K ①    | O        | T      |                         |                         |
| 1.5           | 1 3/4                         | 7                          | 4.41                                      | .55  | 6900               | 10                 | 10                | 6 5/8               | 4 13/32  | 3/32 | 5      | 2 5/32   | 2 5/32         | 4 3/4  | 5 7/8  | 2 3/4  | 2 5/8    | 3/4    | 8 - 3/8                 | 5 - 1/4                 |
| 2             | 2 1/8                         | 12                         | 7.56                                      | .95  | 5900               | 10                 | 10                | 7 3/4               | 4 29/32  | 3/32 | 6 1/8  | 2 13/32  | 2 13/32        | 5 3/4  | 7      | 3      | 3 7/32   | 3/4    | 8 - 3/8                 | 5 - 5/16                |
| 2.5           | 2 5/8                         | 22                         | 13.86                                     | 1.73   | 4800               | 10                 | 10                | 9 1/2               | 5 3/8    | 1/8  | 7 7/8  | 2 5/8    | 2 5/8          | 6 3/4  | 8 3/4  | 3 1/4  | 3 31/32  | 3/4    | 10 - 3/8                | 5 - 3/8                 |
| 3             | 3 3/16                        | 40                         | 25.2                                      | 3.15   | 4100               | 10                 | 10                | 11 1/8              | 6 5/8    | 1/8  | 9 1/2  | 3 1/4    | 3 1/4          | 7 3/4  | 10 3/8 | 4 1/4  | 4 7/8    | 3/4    | 10 - 3/8                | 5 - 7/16                |
| 3.5           | 3 13/16                       | 70                         | 44.1                                      | 5.51   | 3600               | 10                 | 10                | 13 1/4              | 7 7/8    | 1/8  | 11 1/4 | 3 7/8    | 3 7/8          | 10 1/8 | 12 1/4 | 4 3/4  | 5 7/8    | 3/4    | 10 - 1/2                | 5 - 1/2                 |
| 4             | 4 5/8                         | 120                        | 75.6                                      | 9.45   | 3000               | 10                 | 10                | 15 3/4              | 9 1/4    | 1/8  | 13 5/8 | 4 9/16   | 4 9/16         | 10 3/4 | 14 3/4 | 5 3/4  | 7 3/16   | 3/4    | 10 - 1/2                | 5 - 5/8                 |
| 5             | 5 5/8                         | 220                        | 138.6                                     | 17.33  | 2400               | 10                 | 10                | 19 1/8              | 11 3/8   | 1/8  | 16 1/2 | 5 5/8    | 5 9/16         | 10     | 17 7/8 | 7 1/4  | 8 25/32  | 7/8    | 10 - 5/8                | 5 - 3/4                 |
| 6             | 6 7/8                         | 400                        | 252                                       | 31.5   | 1950               | 10                 | 10                | 23 1/2              | 13 1/8   | 3/16 | 20 1/4 | 6 13/16  | 6 1/8          | 12     | 22     | 8 3/4  | 10 5/8   | 1 1/8  | 10 - 3/4                | 5 - 7/8                 |
| 7             | 7 13/16                       | 600                        | 378                                       | 47.25  | 1760               | 10                 | 10                | 26 1/8              | 15 15/16 | 3/16 | 22 7/8 | 7 7/8    | 7 7/8          | 14     | 24 5/8 | 10 1/4 | 12 1/8   | 1 1/2  | 12 - 3/4                | 5 - 7/8                 |
| 8             | 8 5/8                         | 800                        | 504                                       | 63.0   | 1600               | 10                 | 10                | 29                  | 16 15/16 | 3/16 | 25 3/8 | 8 3/8    | 8 3/8          | 15 1/4 | 27 1/4 | 11     | 13 9/16  | 1 1/8  | 16 - 7/8                | 5 - 1                   |
| 9             | 9 7/8                         | 1200                       | 756                                       | 94.5   | 1400               | 10                 | 10                | 33                  | 19 5/16  | 3/16 | 29     | 9 9/16   | 9 9/16         | 17 5/8 | 31     | 12 3/4 | 15 7/16  | 1 3/8  | 16 - 1                  | 5 - 1 1/8               |
| 10            | 10 7/8                        | 1600                       | 1008                                      | 123.5  | 1265               | 10                 | 10                | 36 1/4              | 21 3/4   | 1/4  | 31 1/2 | 10 3/4   | 10 3/4         | 19 1/4 | 34     | 14     | 16 13/16 | 1 7/16 | 16 - 1 1/8              | 5 - 1 1/4               |
| 12            | 12 1/8                        | 2200                       | 1386                                      | 173.3  | 1150               | 10                 | 10                | 40                  | 24       | 1/4  | 35 1/8 | 11 7/8   | 11 7/8         | 21 5/8 | 37 1/2 | 15 3/4 | 18 23/32 | 1 3/4  | 16 - 1 1/4              | 5 - 1 1/2               |
| 13            | 13 1/2                        | 3000                       | 1890                                      | 236.3  | 1110               | 12                 | 24                | 41 1/2              | 28 3/16  | 5/16 | 36     | 13 15/16 | 13 15/16       | 24     | 39     | 9 3/4  | 21 1/32  | 1 3/4  | 20 - 1 1/4              | 6 - 1 1/4               |
| 14            | 14 3/4                        | 4000                       | 2520                                      | 315.0  | 1030               | 12                 | 24                | 44 1/2              | 31 3/4   | 3/8  | 39 3/8 | 15 11/16 | 15 11/16       | 26     | 42     | 11     | 22 29/32 | 1 3/4  | 20 - 1 1/4              | 6 - 1 1/2               |
| 16            | 16 7/8                        | 6000                       | 3780                                      | 472.5  | 960                | 16                 | 32                | 48                  | 36 3/8   | 3/8  | 41 5/8 | 18       | 18             | 29 5/8 | 45     | 13     | 27 5/8   | 2      | 20 - 1 1/2              | 8 - 1 1/8               |

**Table 1 (cont'd.)**

| Coupling Size | WR <sup>2</sup> w/no bores - lb. in. <sup>2</sup> x 10 <sup>-3</sup> |                  |                   |            |         | Finished Weight w/no bores - lbs. |                  |                   |            |         |
|---------------|--|------------------|-------------------|------------|---------|-----------------------------------|------------------|-------------------|------------|---------|
|               | Hub  | Resilient Blocks | Sleeve & End Ring | Rigid Half | ⑤ Total | Hub                               | Resilient Blocks | Sleeve & End Ring | Rigid Half | ⑤ Total |
| 1.5           | .006   | .002             | .043              | .061       | .112    | 4.4                               | .47              | 6.6               | 14         | 25.5    |
| 2             | .013   | .004             | .086              | .126       | .229    | 7.1                               | .84              | 10                | 22         | 40      |
| 2.5           | .036   | .014             | .194              | .280       | .524    | 12                                | 1.7              | 14                | 34         | 61.7    |
| 3             | .091   | .037             | .481              | .572       | 1.181   | 22                                | 3                | 25                | 54         | 104     |
| 3.5           | .223   | .089             | 1.032             | 1.566      | 2.910   | 37                                | 5                | 38                | 101        | 181     |
| 4             | .577   | .222             | 2.480             | 2.715      | 5.994   | 64                                | 9                | 64                | 140        | 277     |
| 5             | 1.579  | .592             | 5.460             | 5.545      | 13.176  | 117                               | 15               | 92                | 198        | 422     |
| 6             | 4.200  | 1.627            | 18.111            | 12.30      | 36.24   | 211                               | 28               | 210               | 290        | 739     |
| 7             | 7.464  | 3.084            | 30.39             | 19.80      | 60.74   | 285                               | 42               | 274               | 437        | 1038    |
| 8             | 12.35  | 5.109            | 47.31             | 39.28      | 104.1   | 378                               | 56               | 353               | 647        | 1434    |
| 9             | 23.48  | 9.820            | 95.76             | 74.56      | 203.6   | 562                               | 83               | 531               | 967        | 2143    |
| 10            | 37.64  | 15.99            | 150.2             | 120.1      | 323.9   | 761                               | 113              | 702               | 1286       | 2862    |
| 12            | 63.45  | 26.96            | 240.1             | 205.2      | 535.6   | 1036                              | 154              | 963               | 1773       | 3926    |
| 13            | 106.9  | 39.57            | 297.3             | 276.9      | 720.7   | 1524                              | 200              | 1064              | 2300       | 5088    |
| 14            | 167.9  | 55.06            | 458.5             | 410.2      | 1092    | 2000                              | 234              | 1361              | 2978       | 6573    |
| 16            | 336.1  | 75.48            | 516.2             | 674.5      | 1602    | 3063                              | 258              | 1327              | 4157       | 8805    |

① Space needed for block removal.

② Number of blocks employed is shown in Tables No. 1 and 2.

③ Vibratory torque values tabulated relate to vibration frequencies up to 500 vib/min. For higher frequencies, coupling vibratory torque capacity is derated on the following basis:

$$T_F = T \sqrt{\frac{500}{F}}$$

Where  $T_F$  = Vibratory torque capacity (lb. in.) at frequency  $F$  (vib/min.).  
 $T$  = Vibratory torque (lb. in.) from table.  
 $F$  = Frequency (vib/min.) at which torque capacity is required.

④ A reduction in maximum bore is required for limited end float couplings, please consult KOP-FLEX.

⑤ Weight and WR<sup>2</sup> values are based on ductile iron hubs and sleeves, and steel forged rigids and end rings.

⑥ Max. speeds based on ductile iron. Greater speeds allowed for forged steel.



Visit [www.kopflex.com](http://www.kopflex.com)

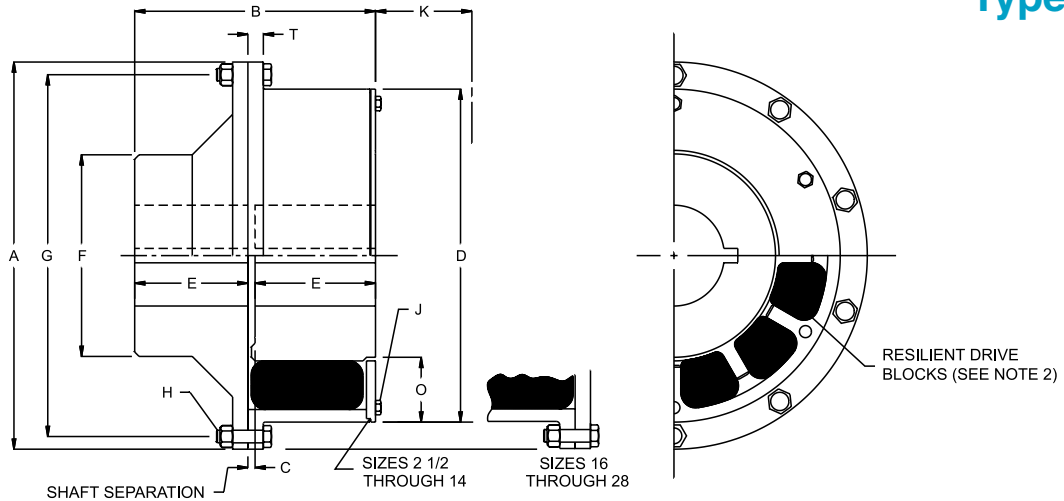

**Table 2**

| Coupling Size | ④ Max. Bore of Flex Hub (in.) | Peak Capacity (HP/100 RPM) | Peak Torque (lb.-in. x 10 <sup>-3</sup> ) | ③ Vibratory Torque (lb.-in. x 10 <sup>-3</sup> ) | ⑥ Max. Speed (RPM) | Number of Cavities | ② Number of Block | DIMENSIONS (INCHES) |         |       |         |         |          |        |        |        |        | Bolts - No. & Dia. (in.) | Bolts - No. & Dia. (in.) |
|---------------|-------------------------------|----------------------------|---|--|--------------------|--------------------|-------------------|---------------------|---------|-------|---------|---------|----------|--------|--------|--------|--------|--------------------------|--------------------------|
|               |                               |                            |   |  |                    |                    |                   | A                   | B       | C     | D       | E       | F        | G      | K ①    | O      | T      |                          |                          |
| 2.5           | 3                             | 40                         | 25  | 3.1  | 4470               | 12                 | 12                | 10 1/4              | 5 5/8   | 1/8   | 8 7/16  | 2 3/4   | 4 1/2    | 9 3/8  | 2 7/8  | 4 1/4  | 3/4    | 12 - 3/8                 | 6 - 3/8                  |
| 3             | 3 1/2                         | 72                         | 46  | 5.8  | 3700               | 12                 | 12                | 11 5/8              | 7 1/8   | 1/8   | 9 15/16 | 3 1/2   | 5 13/16  | 10 7/8 | 3 5/8  | 5 1/4  | 3/4    | 12 - 3/8                 | 6 - 3/8                  |
| 3.5           | 4 1/4                         | 140                        | 88  | 11   | 3250               | 12                 | 12                | 14 1/8              | 8 21/32 | 5/32  | 12 1/16 | 4 1/4   | 7        | 13 1/8 | 5 1/8  | 5 3/4  | 3/4    | 12 - 1/2                 | 6 - 7/16                 |
| 4             | 5                             | 200                        | 127                                       | 16   | 2700               | 12                 | 12                | 16 3/8              | 9 21/32 | 5/32  | 14 1/4  | 4 3/4   | 8 1/8    | 15 3/8 | 5 1/8  | 8      | 3/4    | 12 - 1/2                 | 6 - 1/2                  |
| 4.5           | 5 1/4                         | 330                        | 210                                       | 26   | 2660               | 12                 | 12                | 17 1/4              | 10 1/16 | 3/16  | 15 1/8  | 4 15/16 | 8 1/2    | 16 1/4 | 7      | 8      | 3/4    | 12 - 1/2                 | 6 - 1/2                  |
| 5.5           | 6 7/8                         | 530                        | 330                                       | 41   | 2210               | 14                 | 14                | 20 3/4              | 11 3/8  | 1/4   | 18      | 5 9/16  | 10       | 19 1/2 | 7      | 10 1/2 | 7/8    | 14 - 5/8                 | 7 - 5/8                  |
| 6             | 7 7/8                         | 800                        | 500                                       | 62   | 2030               | 16                 | 16                | 22 5/8              | 12 1/2  | 1/4   | 19 7/8  | 6 1/8   | 12       | 21 3/8 | 8      | 12 1/8 | 7/8    | 16 - 5/8                 | 8 - 5/8                  |
| 6.5           | 8 1/2                         | 1200                       | 750                                       | 94   | 1840               | 16                 | 32                | 24 7/8              | 15 1/2  | 1/4   | 21 5/8  | 7 5/8   | 12 5/16  | 23 3/8 | 10     | 13 1/8 | 1 1/8  | 16 - 3/4                 | 8 - 3/4                  |
| 7             | 9 1/8                         | 1600                       | 1010                                      | 126  | 1710               | 16                 | 32                | 26 7/8              | 17 1/4  | 1/2   | 23 1/8  | 8 3/8   | 14       | 25 1/8 | 14     | 14 1/8 | 1 1/8  | 16 - 7/8                 | 8 - 3/4                  |
| 8             | 10 3/4                        | 2150                       | 1350                                      | 170  | 1560               | 18                 | 36                | 29 3/8              | 18      | 1/2   | 25 5/8  | 8 3/4   | 14 3/4   | 27 5/8 | 6 1/2  | 16 5/8 | 1 1/8  | 18 - 7/8                 | 9 - 3/4                  |
| 9             | 11 1/4                        | 2650                       | 1660                                      | 210  | 1470               | 18                 | 36                | 31 1/8              | 20      | 1/2   | 26 3/4  | 9 3/4   | 16       | 29 1/8 | 7 1/4  | 17 1/2 | 1 1/8  | 18 - 1                   | 9 - 3/4                  |
| 10            | 13 1/8                        | 3850                       | 2420                                      | 300  | 1320               | 20                 | 40                | 34 3/4              | 21 1/2  | 1/2   | 30 1/2  | 10 1/2  | 17 15/16 | 32 3/4 | 7 3/4  | 20 1/2 | 1 1/8  | 20 - 1                   | 10 - 7/8                 |
| 11            | 15                            | 5300                       | 3350                                      | 420  | 1200               | 20                 | 40                | 38 1/4              | 25 1/2  | 1/2   | 33 5/8  | 12 1/2  | 20       | 36     | 9 1/8  | 23 3/8 | 1 7/16 | 20 - 1 1/8               | 10 - 7/8                 |
| 12            | 16                            | 8200                       | 5160                                      | 645  | 1100               | 22                 | 44                | 41 3/4              | 30      | 1/2   | 36 1/2  | 14 3/4  | 22 3/4   | 39 1/4 | 10 3/4 | 25 1/4 | 1 1/2  | 22 - 1 1/4               | 11 - 1                   |
| 14            | 17 5/8                        | 11500                      | 7200                                      | 900  | 1020               | 24                 | 48                | 44 3/4              | 32 3/4  | 3/4   | 39 1/2  | 16      | 25 1/4   | 42 1/4 | 11 7/8 | 27 3/4 | 1 1/2  | 24 - 1 1/4               | 12 - 1                   |
| 16            | 21 1/4                        | 15000                      | 9500                                      | 1190   | 880                | 24                 | 72                | 52 1/4              | 34 1/4  | 3/4   | 46      | 16 3/4  | 28 13/16 | 49 1/4 | 12 3/8 | 33 1/2 | 2      | 24 - 1 1/2               | 12 - 1 1/8               |
| 19            | 25                            | 27200                      | 17100                                     | 2140   | 750                | 28                 | 84                | 61 1/4              | 40 3/4  | 3/4   | 53 3/4  | 20      | 35 1/4   | 57 3/4 | 14 1/4 | 39 1/2 | 2 1/4  | 28 - 1 3/4               | 14 - 1 1/4               |
| 22            | 34                            | 45000                      | 28300                                     | 3540   | 580                | 32                 | 96                | 79 1/2              | 49      | 1     | 70      | 24      | 40       | 75     | 14 1/4 | 54 1/2 | 2 3/4  | 32 - 2 1/4               | 16 - 1 1/2               |
| 25            | 34                            | 67000                      | 42300                                     | 5290   | 580                | 32                 | 160               | 79 1/2              | 58 3/4  | 1 3/4 | 70      | 28 1/2  | 44 13/16 | 75     | 21 1/4 | 54 1/2 | 2 3/4  | 32 - 2 1/4               | 16 - 1 1/2               |
| 28            | 34                            | 90000                      | 56500                                     | 7060   | 580                | 32                 | 192               | 79 1/2              | 74 1/2  | 4 1/2 | 70      | 35      | 51 1/4   | 75     | 28 1/8 | 54 1/2 | 2 3/4  | 32 - 2 1/4               | 16 - 1 1/2               |

**Table 2 (cont'd.)**

| Coupling Size | ⑤ WR <sup>2</sup> w/no bores - lb. in. <sup>2</sup> x 10 <sup>-3</sup> |                  |                   |            |       | ⑤ Finished Weight w/no bores - lbs. |                  |                   |            |       |
|---------------|--|------------------|-------------------|------------|-------|-------------------------------------|------------------|-------------------|------------|-------|
|               | Hub  | Resilient Blocks | Sleeve & End Ring | Rigid Half | Total | Hub                                 | Resilient Blocks | Sleeve & End Ring | Rigid Half | Total |
| 2.5           | .052   | .016             | .275              | .239       | .582  | 13                                  | 1.5              | 17                | 26         | 58    |
| 3             | .132   | .039             | .515              | .507       | 1.19  | 26                                  | 2.7              | 24                | 47         | 99.7  |
| 3.5           | .346   | .124             | 1.33              | 1.11       | 2.91  | 46                                  | 6                | 43                | 74         | 169   |
| 4             | .921   | .248             | 2.29              | 2.33       | 5.79  | 81                                  | 8                | 51                | 120        | 260   |
| 4.5           | .977   | .431             | 3.66              | 2.65       | 7.72  | 82                                  | 13               | 77                | 127        | 299   |
| 5.5           | 2.83   | .932             | 8.44              | 6.73       | 18.93 | 153                                 | 19               | 122               | 210        | 504   |
| 6             | 5.38   | 1.53             | 12.62             | 9.96       | 29.49 | 224                                 | 24               | 149               | 276        | 673   |
| 6.5           | 9.27   | 2.71             | 23.4              | 18.2       | 53.58 | 327                                 | 38               | 231               | 403        | 999   |
| 7             | 13.81  | 3.99             | 32.12             | 26.33      | 76.25 | 424                                 | 48               | 277               | 507        | 1256  |
| 8             | 25.35  | 6.14             | 44.19             | 37.17      | 112.9 | 593                                 | 57               | 311               | 628        | 1589  |
| 9             | 34.12  | 8.31             | 60.0              | 54.7       | 157.1 | 727                                 | 70               | 374               | 810        | 1981  |
| 10            | 66.3   | 13.9             | 104               | 88.6       | 272.8 | 1060                                | 89               | 510               | 1075       | 2734  |
| 11            | 127.1  | 23.87            | 169.8             | 155.8      | 476.6 | 1600                                | 127              | 672               | 1560       | 3959  |
| 12            | 209  | 37.3             | 280               | 246        | 772   | 2209                                | 162              | 956               | 2180       | 5507  |
| 14            | 331  | 59.1             | 390               | 360        | 1140  | 2929                                | 216              | 1140              | 2790       | 7075  |
| 16            | 708  | 107              | 986               | 757        | 2558  | 4397                                | 281              | 1980              | 4070       | 10730 |
| 19            | 1640   | 230              | 2250              | 1790       | 5910  | 7138                                | 439              | 3370              | 6990       | 17940 |
| 22            | 5390   | 619              | 6660              | 5350       | 18020 | 13530                               | 659              | 5570              | 12600      | 32360 |
| 25            | 7650   | 920              | 7920              | 6600       | 23090 | 19130                               | 979              | 6710              | 15900      | 42720 |
| 28            | 10000  | 1220             | 9180              | 9520       | 29920 | 24620                               | 1300             | 7840              | 22200      | 55960 |

Performance values are based on 60° durometer or harder drive blocks. Maximum torque is reduced for softer (50° durometer or less) drive blocks.

USER NOTICE: The ratings of the MAX-C® coupling from KOP-FLEX® brand couplings were established using the exceptional properties of KOP-FLEX® brand elastomers. The use of any other material or manufacture can severely alter the coupling performance. If replacement is ever necessary, the elastomer blocks should only be replaced with KOP-FLEX® brand elastomer blocks.



### Service Factors - Type CB and WB

#### (1) SERVICE FACTORS:

|   |               |                 |  |
|---|---------------|-----------------|--|
| Prime Movers:                                       | <u>Factor</u> |                 | <u>Factor</u>  |
| Smooth Torque Turbines & Turbines & Electric Motors | 0             | Diesel Engines- | 6 or more cylinders 1<br>4 cylinders 2<br>1, 2, 3, & 5 cylinders 3 |
| Synchronous Motors & Variable Frequency AC Motors   | 1             |                 |  |

| DRIVEN MACHINE                   | SERVICE FACTOR | DRIVEN MACHINE                 | SERVICE FACTOR | DRIVEN MACHINE                      | SERVICE FACTOR |
|----------------------------------|----------------|--------------------------------|----------------|-------------------------------------|----------------|
| Agitators                        | 2              | Disintegrators                 | 2.5            | Paddle Wheels                       | 3              |
| Autogenous Grinding Mills        | 2.5            | Drawbench (Tube Mill)          | 3.5            | Planers - Reversing                 | 2.5            |
| Ball Mills                       | 2.5            | Dynamometers                   | 2              | Propellers - Marine                 | 2              |
| Banbury Mixers                   | 3              | Edger Drives                   | 4              | Pulp Grinders                       | 3.5            |
| Bar Mills                        | 3              | Exhausters                     | 2              | Pulverizers                         | 2              |
| Bar Reeling Machine              | 2.5            | Fans - Centrifugal             | 2              | Pusher Drive                        | 3              |
| Bar Straightening Machine        | 3.5            | Fans - Mine Ventilating        | 2.5            | Runout Tables                       | 2.5            |
| Blooming Mills                   | 4              | Feed Rolls - Reversing         | 8              | Rod Mills                           | 2.5            |
| Blower - Lobe or Vane            | 2              | Feed Rolls - Unidirectional    | 3              | Sawing Machines                     | 2              |
| Cement Mills                     | 2.5            | Fluid Mixers                   | 2              | Shearing Machines                   | 3              |
| Cold Mills                       | 3              | Forging Machine - Belt Driven  | 2              | Slabbing Mills                      | 4              |
| Compressors - Axial Screw (air)  | 2              | Forging Machine - Direct Drive | 2              | Tube Mill                           | 3.5            |
| Compressors - Centrifugal        | 2              | Hoists                         | 3              | Welding Generators                  | 2.2            |
| Compressors - Rotary, Lobe       | 2              | Hot Strip Mills                | 4              | Winch and Capstans                  | 2              |
| Compressors - Reciprocating      | 4              | Kiln Drive                     | 3              | Winder                              | 3              |
| Compressors- Quadruple or Radial | 2              | Machine Tools                  | 2              | Wire Mills                          | 2              |
| Conveyors - Belt, Chain, Screw   | 2              | Manipulators                   | 4              |                                     |                |
| Conveyors - Bucket               | 2              | Pumps - Centrifugal            | 2              | For Driven Machine Types Not Listed |                |
| Cranes - Main & Auxiliary Hoist  | 3              | Pumps - Dredge                 | 2              | Use the Following Guidelines:       |                |
| Cranes - Cross Traverse          | 3              | Pumps - Rotary or Gear         | 2              | Low Shock                           | 2-2.5          |
| Cranes - Long Travel             | 3              | Pumps - Ram                    | 3              | Medium Shock                        | 2.5-3          |
| Crushers - Cane                  | 3              | Pumps - Reciprocating          | 3              | Heavy Shock                         | 3-4            |
| Crushers - Rock, Ore             | 4              |                                |                |                                     |                |

**NOTE (1) - CB Coupling** Total System Service Factor must be **3 minimum**.

#### (2) ALLOWABLE MISALIGNMENT

| CPLG. SIZE | CB COUPLINGS |             |                   | CPLG. SIZE | WB COUPLINGS |             |                   | CPLG. SIZE | WB COUPLINGS |             |                   |
|------------|--------------|-------------|-------------------|------------|--------------|-------------|-------------------|------------|--------------|-------------|-------------------|
|            | AXIAL (in)   | RADIAL (in) | ANGULAR (Degrees) |            | AXIAL (in)   | RADIAL (in) | ANGULAR (Degrees) |            | AXIAL (in)   | RADIAL (in) | ANGULAR (Degrees) |
| 1 1/2      | .025         | .015        | 1/2               | 2 1/2      | .030         | .020        | 1/2               | 9          | .060         | .040        | 1/2               |
| 2          | .025         | .015        | 1/2               | 3          | .030         | .020        | 1/2               | 10         | .060         | .040        | 1/2               |
| 2 1/2      | .030         | .020        | 1/2               | 3 1/2      | .035         | .025        | 1/2               | 11         | .060         | .040        | 1/2               |
| 3          | .030         | .020        | 1/2               | 4          | .035         | .025        | 1/2               | 12         | .060         | .040        | 1/2               |
| 3 1/2      | .030         | .020        | 1/2               | 4 1/2      | .045         | .025        | 1/2               | 14         | .060         | .040        | 1/2               |
| 4          | .030         | .020        | 1/2               | 5 1/2      | .050         | .035        | 1/2               | 16         | .060         | .040        | 1/2               |
| 5          | .030         | .020        | 1/2               | 6          | .050         | .035        | 1/2               | 19         | .090         | .060        | 1/2               |
| 6          | .045         | .030        | 1/2               | 6 1/2      | .050         | .035        | 1/2               | 22         | .125         | .080        | 1/2               |
| 7          | .045         | .030        | 1/2               | 7          | .060         | .040        | 1/2               | 25         | .125         | .080        | 1/2               |
| 8          | .045         | .030        | 1/2               | 8          | .060         | .040        | 1/2               | 28         | .125         | .080        | 1/2               |
| 9          | .045         | .030        | 1/2               |            |              |             |                   |            |              |             |                   |
| 10         | .060         | .040        | 1/2               |            |              |             |                   |            |              |             |                   |
| 12         | .060         | .040        | 1/2               |            |              |             |                   |            |              |             |                   |
| 13         | .080         | .050        | 1/2               |            |              |             |                   |            |              |             |                   |
| 14         | .090         | .060        | 1/2               |            |              |             |                   |            |              |             |                   |
| 16         | .090         | .060        | 1/2               |            |              |             |                   |            |              |             |                   |

**NOTE (2)-** (a) Tables show allowable simultaneous misalignment limits for speeds up to 500 RPM.  
 (b) Angular misalignment values based on shaft centerlines intersecting at the vertical centerline of rubber blocks.  
 (c) Calculation of radial and angular misalignment limits for speeds exceeding 500 RPM:

$$\text{New Limit} = \text{Tabulated Value} \times \sqrt{\frac{500}{\text{Operating RPM}}}$$

(d) Normal installations should be aligned initially as accurately as possible, generally within 25% of the tabulated values.



Visit [www.kopflex.com](http://www.kopflex.com)

# KOP-FLEX®

**We shipped a main mill drive coupling in less than 24 hours!**



*Surrounded by some of our extensive inventory, KOP-FLEX's operations manager readies a Size #26 for shipment to a customer*

■ **“Stock” couplings ready for immediate shipment**

KOP-FLEX maintains a full inventory of rough bored main drive couplings from Sizes #1-30, to fit bores up to 40" (1,000mm.) in diameter. We can ship these immediately.

■ **Finish bored and keywayed fast**

The plant is open 24 hours a day, seven days a week. Call in your shaft information anytime, including weekends. KOP-FLEX will work around-the-clock to finish bore and keyway a coupling to your specifications.

■ **Quick turnaround on custom applications**

KOP-FLEX also stocks composite forgings for mill drive couplings. We can quickly machine these forgings to satisfy special requirements like flange boltings, non-standard hub lengths, etc.

■ **Proven performers in the mill**

KOP-FLEX has over 80 years of proven performance in mill duty couplings. Thousands of our heavy duty couplings are in service, many with over 50 years of continuous operation. Our engineering staff is second to none in the industry. Take advantage of their extensive coupling knowledge. We eagerly await an opportunity to work with you.



*KOP-FLEX stocks a complete line of forgings, ready for custom machining.*

**For immediate service call 410-768-2000**