



the power of
EPT

KOP-FLEX®

**Powerlight®
Torque
Monitoring
System**



EMERSON
Industrial Automation

EMERSON. CONSIDER IT SOLVED.™



Accuracy to within $\pm 1\%$
Unequaled reliability
Experience with proven success
Single source for coupling-torque monitoring system

Kop-Flex® – The Widest Range of Coupling Solutions

Kop-Flex offers the broadest range of coupling products on the market today. From high performance, high-speed disc, diaphragm and gear couplings to off-the-shelf standard couplings, Kop-Flex also provides engineered gear, grid, jaw, elastomer, disc, universal joints and customized couplings to meet your unique application challenges.

Kop-Flex high performance couplings fulfill customers' needs for demanding turbomachinery applications such as steam or gas turbines; compressor, generator, motor driven drives; boiler feed pumps and special pumps for industries ranging from petrochemical, refinery, power plants, LNG, gas pipeline, test stands and more. Couplings meet API 671, ISO 10441, API 610, ISO 13709 and other industry standards.

Kop-Flex also offers coupling products for rolling mills and casters in steel mills, paper machines (both wet and dry ends), mines, liquid handling pumps and motors (for processing or liquid handling applications) and more.

A History of Innovation & Design Excellence

Powerlign® Performance Torque Monitoring System for Coupling Applications

From the invention of Fast's® – the world's first gear coupling – to today's high performance couplings, Kop-Flex has a rich industry background and a reputation for solving customer problems.

Faced with rising fuel costs and increasing environmental concerns such as No_x (*nitrous oxide*) emissions standards, torque meters are increasingly being used to measure power, speed and torque on critical rotating machine equipment.

Torque differentials can indicate performance problems such as blade fouling and over-torque can lead to coupling shaft or equipment failure. When performance declines, more fuel is burned and No_x emissions increase. Torque meters provide a cost-effective method for diagnosing these problems early on so you can make the necessary adjustments to your system for a proactive maintenance plan.

From Simple Diagnostics to True Control

As the only company in the world that has developed an integrated coupling-torque meter solution, Kop-Flex introduces the newly designed, digital Powerlign Performance Torque Monitoring System.

As the most reliable, accurate torque meter available in today's marketplace, the digital Powerlign replaces the proven, analog Powerlign system that has served the market for the last ten years. Powerlign features a patented, unique architecture that allows for more advanced system control with full integration support for distributed control systems (*DCS*) such as Emerson Process Management's DeltaV™ system or PCs and laptops for analyzing system data.

Powerlign acts as an important part of a closed loop system by establishing certain thresholds that can be configured to trigger an alert or alarm. Powerlign can also be used as a control system to shut down equipment or direct the in flow of gas or fuel to maintain load and efficiency.

Key Benefits

- All new, **digital** phase-shift, non-strain gauge system
- As a **single source supplier** of couplings and torque meters, Kop-Flex eliminates coordination and design integrity issues that occur with multiple suppliers
- Simplicity of design reduces margin for error—with accuracy within $\pm 1\%$
- **Safety and reliability** – unlike other torque measuring devices, no electronics or electrical power is present in the coupling or in the coupling environment
- **Seamless integration** – connect the Powerlign conditioning unit directly to a DCS like the DeltaV system or others running public or private MODBUS protocol, reducing the cost of setting another box or training your operator to use a new system
- **Retrofit** - For most applications, a new instrumented spacer can be inserted without disturbing the existing flex half couplings

No Other Torquemeter System Offers Consistent Accuracy

The accuracy rating is determined as a root sum of the squares series of all the individual errors possible, both electrical and mechanical.

The mechanical inaccuracies include allowances for the inevitable movements of the coupling in relation to the guard-mounted sensor, during hot and cold cycles of equipment operation. These are the radial gap and axial movement errors. Other mechanical errors are possible from the various calibrations and set-ups.

Electrical items include sensor variation and conditioning unit variation. Note that because these errors are included in the overall budget, sensors and boxes from the factory or stock can be swapped out in the field without degradation of accuracy. Powerlign and Powerwheel are accurate to within one percent.

- Specially configured MODBUS communication protocol available to fit with your **existing DCS**
- **Significant cost savings** – considering that a 40MW gas turbine consumes \$8,000,000/year in 2003 fuel costs, a one percent increase in efficiency equates to \$80,000 in annual savings
- Aids in **environmental compliance** efforts by helping to reduce No_x emissions through improved fuel monitoring
- **Completely interchangeable** components and no need for recalibration
- **Highly flexible** – fewer components, easier to install and no need to disturb or modify any vents, drains, filters, etc
- ATEX, CE and CSA certification for explosion proof sensors (Div I), intrinsically safe conditioning unit and display unit (Div II) operation
- RS-232 digital, RS-485 digital and 4-20mA analog output
- Decreased lead times
- Reduced wiring cost
- Uses existing coupling guard
- User configurable imperial inch or metric (SI) units
- Built-in, automatic temperature compensation; sensors operate at temperatures as high as 350° F (177°C) to accommodate the most demanding environments



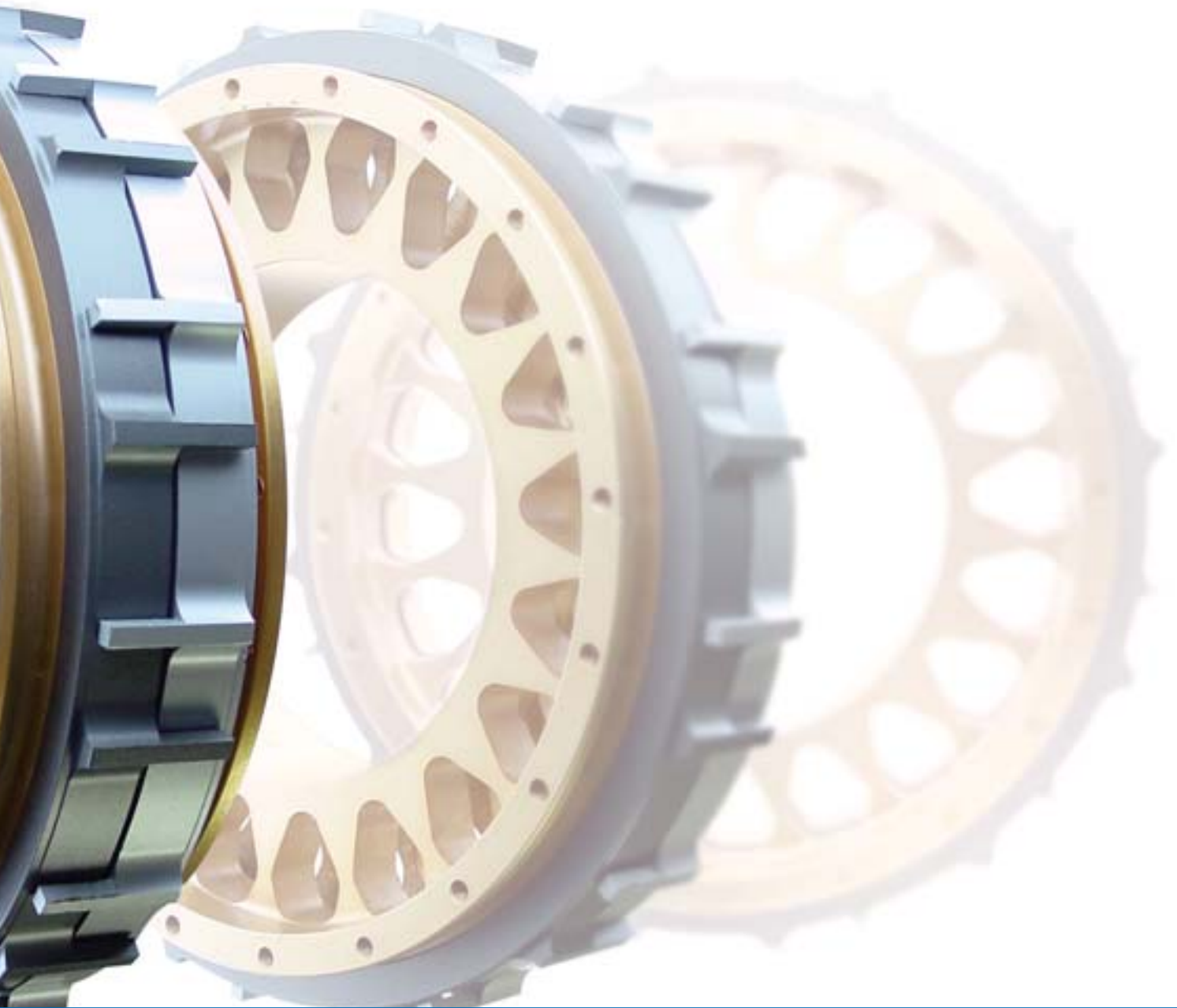

Improved Accuracy and Performance

Powerlign was originally designed to meet grueling, specific aerospace standards. Powerlign is unequalled in performance and proven reliability.

Powerlign and Powerwheel

Covering a Range of Applications

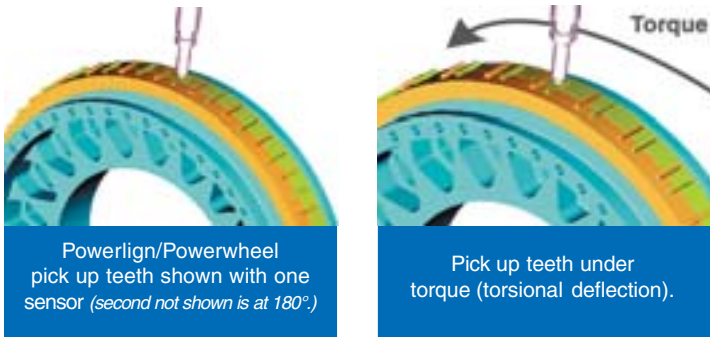

How Powerlign & Powerwheel Work

Powerwheel features the same patented design as Powerlign in a smaller footprint with a specifically profiled double-sided wheel, where teeth mounted to the outer diameter of one wheel move relative to teeth mounted on the mating wheel. Similar to Powerlign, sensors detect this movement but instead, deflection occurs in profiled spokes in each wheel in combination with a short, tubular section that connects the wheels.

Mechanical wheel or spacer – Powerlign includes intermeshed, pick-up teeth, mounted on a spacer on the coupling. The applied torque causes the spacer and wheel, to torsionally deflect, resulting in torsional twist.

In the Powerwheel design, the “twist for torque” measurement occurs in a compact, specifically profiled double wheel, where teeth mounted to the outer diameter of one wheel move relative to teeth mounted on the outer diameter of a mating wheel.

Sensors – two, monopole sensors, from reference points on the wheel, pick up this torsional twist. The sensors are mounted on the existing coupling guards by welding a boss plate to the guards, hence they do not rotate with the coupling and the pick-up teeth. The sensors are inserted into the boss plates, and the gap is set with a depth micrometer or feeler gauges. The boss plate orientations are usually installed at a 45° angle to avoid conflicts with drainpipes, vents, etc. As each set of teeth passes the sensor, a waveform is created.

Conditioning unit – the waveform is transmitted to a processor within the conditioning unit, which translates the twist into torque based on a series of measurements and constants. It also monitors the coupling’s speed and temperature. Internal circuits continuously use temperature information to

automatically compensate for temperature-associated changes in coupling stiffness. Because processing occurs close to the sensors, greater accuracy results due to reduced wire transmission.

The conditioning unit is mounted within 500 feet of the sensors and transmits data via cable, RS-485 and a public MODBUS protocol (an industry standard format, recognizable by most DCS). Powerlign can also be configured to transmit data over wireless networks or other communication protocols. (Contact Kop-Flex for details.) The conditioning unit also automatically checks and corrects itself every 24 hours for any electronic drift, eliminating the need for field calibration.

Standalone display unit – the standalone unit receives the digital signal and displays (but does not store) torque, speed and temperature data at approximately one-second intervals. Powerlign can transmit 4,000 feet whereas competitive designs only transmit up to 1,000 feet. This provides a greater range for signal transmission to the standalone display unit or the DCS, eliminating the need for expensive, cross-site cabling and providing flexibility in locating the diagnostic system. The display unit provides RS-232 digital and 4-20 mA analog output signals.

DCS (in lieu of display unit) – the conditioning unit can connect directly to your DeltaV or other DCS, via RS-485 cable or wireless (as an option) using public or private MODBUS protocol.

The Origin of Powerwheel

To develop Powerwheel, Kop-Flex modified the same, proprietary, numerical analysis used for Kop-Flex diaphragm couplings then proved the design software with FEA, R&D and field tests. One back-to-back test connected a Powerlign torquemeter directly to a Powerwheel torquemeter, loaded with torque at high speeds. Each meter had a separate probe and an independent electronic system. Correlation results were excellent, within 0.3% of full-scale torque.

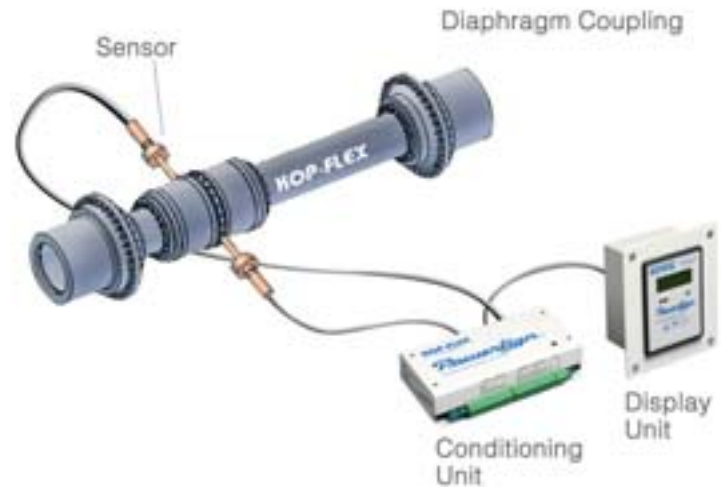

Powerlign with Conditioning Unit & Display

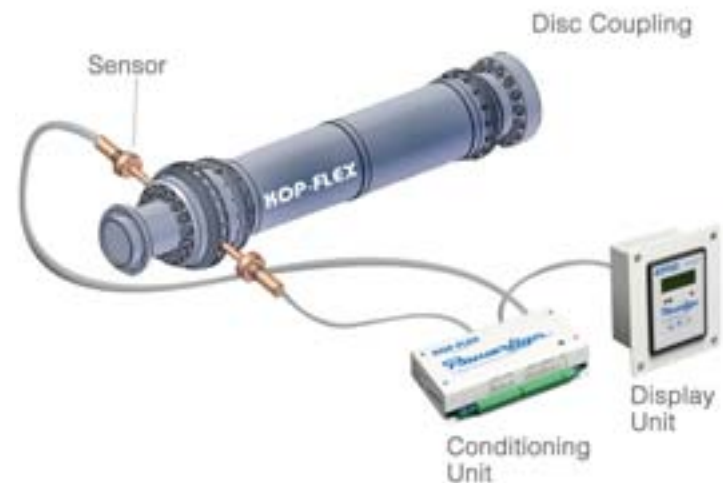

Powerwheel with Conditioning Unit & Display

Major Customers and Applications

OEMS

Dresser Rand
Ebara
Elliot
G.E./A.C. Compressor
Man Turbo
Mitsubishi
Nuovo Pignone (GE)
Planergy
Rolls Royce
Siemens
Solar Turbine

Users:

BP Amoco
Exxon Mobil*
Linde Adnoc
Nova Chemical
Petrokemya
Petronas
SECL Malaysia
Sulzer
Syncrude
Transcanada Pipeline

Industries:

Petrochemical plants
Gas pipelines
Natural gas
Refineries
LNG
Test stands
Power plants
Marine propulsion
Energy storage

Applications:

Compressor to compressor
Motor to compressor
Performance testing
Turbine to boiler feed pump
Turbine (gas or steam)
to compressors
Turbine to generator
Test stands
Expander
Gas reinjection

*The first Powerlign unit shipped in 1995 and is still running continuously and successfully.



Capabilities	Powerlign	Powerwheel
Torque	<i>No upper limit</i>	<i>No upper limit</i>
Speed	<i>Typically up to 8,000 rpm</i>	<i>up to 20,000 rpm</i>
Shaft Separation	<i>18 to 48 inches (.5 to 1.2m)</i>	<i>5 to 180 inches (127 mm to 4.5m)</i>
Unbalanced Sensitivity	<i>For less sensitive</i>	<i>For most sensitive</i>

Types of Torquemeters

Phase displacement torquemeter – measures coupling spacer twist when torque is applied by measuring the change in phase or shift between the two sets of pick-up teeth. Both Powerlign and Powerwheel are phase displacement torquemeters. Phase displacement is the better choice for long-term use because it provides uninterrupted service, higher accuracy and does not require field-calibration.

Strain gauge torquemeter – has a strain gauge or Wheatstone bridge attached to the spacer. An FM signal is transmitted to the processor through a stator ring. Although there have been many successful field installations, users consider the strain-gauge torquemeter as a weak system as it loses accuracy and reliability over time and has temperature limitations.



Retrofitting and Options

Covering a Range of Applications

LM 2500 Gas Turbine Drop-In Powerwheel into any existing coupling

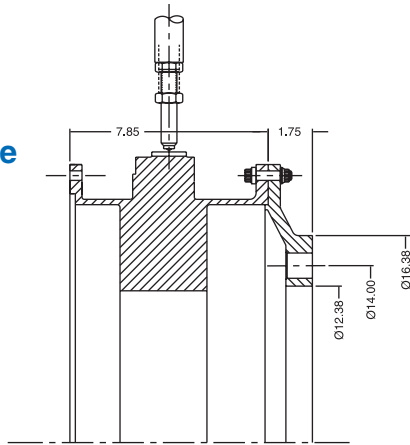

Retrofitting Existing Diaphragm Coupling

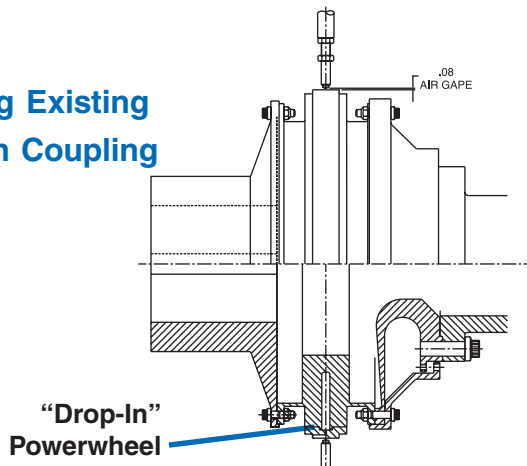

Retrofitting Existing Gear Coupling

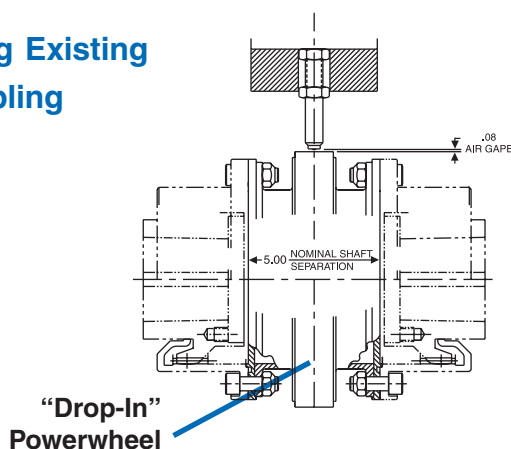

Retrofitting: Until now, retrofitting turbomachinery equipment with torque meter systems was almost impossible. The modular Powerwheel Performance Torque Monitoring System solves this problem. A shorter replacement coupling, or existing coupling spacer, are designed to meet the torque and speed requirements, retrofit criteria and envelope dimensions of the existing application. The modular wheel is a drop-in component of the high-speed coupling. In most cases, the existing guard can be utilized, eliminating the high cost of designing and manufacturing a new guard. The monopole sensors are easily installed by cutting two, 4.5" diameter holes at 180 degrees.

Powerwheel can be retrofitted in any coupling, regardless of the manufacturer. Every effort is made to match the mass elastic data of the coupling to ensure reliable, trouble-free operation. Powerwheel also offers designers the ability to move the wheel to a more suitable location when lateral critical speed is a concern.

Options:

- Windows-PC compatible data storage and graphics package for trend analysis
- Field service technicians for installation supervision and training
- Cross site cables
- Integration with DCS
- Wireless transmission



Worldwide Service & Support

Kop-Flex consistently responds to customer needs for reliable, safe, maintenance-friendly products by demonstrating an attention to detail that is highly valued in the marketplace. Kop-Flex also has the market's largest stock of critical couplings for overnight delivery to support a company-wide priority on helping customers maintain uptime.

Kop-Flex offers extensive service and repair capabilities in Baltimore, Rexdale, Ontario, Canada and our latest coupling plant in Slovakia. All locations are ISO 9000 certified. Additional licensed repair facilities are located within partners' locations in Indiana, Alabama, Texas and California. With manufacturing and service facilities in the U.S. and now in Europe, Kop-Flex can service customers throughout the world.

All Kop-Flex facilities are state-of-the-art, with access to a large and experienced engineering staff. A dedicated service center team, including expert engineers, customer service representatives and repair coordinators, assist in field installation and troubleshooting to manage all your coupling maintenance needs – regardless of the type or the manufacturer.

Kop-Flex practices an extensive inspection process and can repair or refurbish any coupling – including designs produced by other manufacturers. Customer risk is further reduced with the full Kop-Flex warranty.

iCAP—Helpful Online Tools

Kop-Flex created a unique online design tool, called iCAP™, that designs couplings per API/ISO or customer specifications. The tool also generates mass elastic data and creates CAD drawings, including a bill of materials. This helps you confirm that a proposed coupling solution will meet stated requirements and rotor dynamics. The resulting design is viewable online and can be downloaded in various formats. For more information, visit www.kopflex.com/product-selection or contact a Kop-Flex representative in your area.

KOP-FLEX®

KOP-FLEX
WWW.KOPFLEX.COM
1-416-675-6764

Powerlight
TORQUE MONITORING SYSTEM

For ordering information, contact your authorized distributor or Kop-Flex Customer Service at:

Kop-Flex, Inc. (Worldwide)
P.O. Box 1696
Baltimore, MD 21203 (U.S.A.)
Telephone 1-410-768-2000
Fax 1-410-787-8424

Kop-Flex Canada, Ltd.
19 Meteor Drive
Rexdale, ONT M9W 1A3
Telephone 1-416-675-7144
Fax 1-416-675-6764

Kop-Flex, Inc.
5-7 Broadway Parade
Elm Park Avenue
Hornchurch, Essex RM12 4RS
United Kingdom
Telephone 44-1708-475635
Fax 44-1708-455880

e-mail: coupling-engineering@emerson-ept.com
General Contact (Emerson Power Transmission) 1-800-626-2120

www.kopflex.com

www.emerson-ept.com

Connect Here to be Part of Something Bigger

APPLICATION CONSIDERATIONS

The proper selection and application of power transmission products and components, including the related area of product safety, is the responsibility of the customer. Operating and performance requirements and potential associated issues will vary appreciably depending upon the use and application of such products and components. The scope of the technical and application information included in this publication is necessarily limited. Unusual operating environments and conditions, lubrication requirements, loading supports, and other factors can materially affect the application and operating results of the products and components and the customer should carefully review its requirements. Any technical advice or review furnished by Emerson Power Transmission Corporation and its divisions with respect to the use of products and components is given in good faith and without charge, and Emerson assumes no obligation or liability for the advice given, or results obtained, all such advice and review being given and accepted at customer's risk.

For a copy of our Standard Terms and Conditions of Sale, Disclaimers of Warranty, Limitation of Liability and Remedy, please contact Emerson Power Transmission Customer Service at 1-800-626-2120. These terms and conditions of sale, disclaimers and limitations of liability apply to any person who may buy, acquire or use an Emerson Power Transmission Corporation product referred to herein, including any person who buys from a licensed distributor of these branded products.