

ACCS/RM Gear Coupling Continuous Lubrication Sizes #1 1/4 - #7

ACCS/RM nomenclature denotes:
AC—Series AC coupling,
C—continuous oil lubrication, S—oil
introduced thru the spacer, and
RM—reduced moment.

- Lightweight
- Low overhung moment

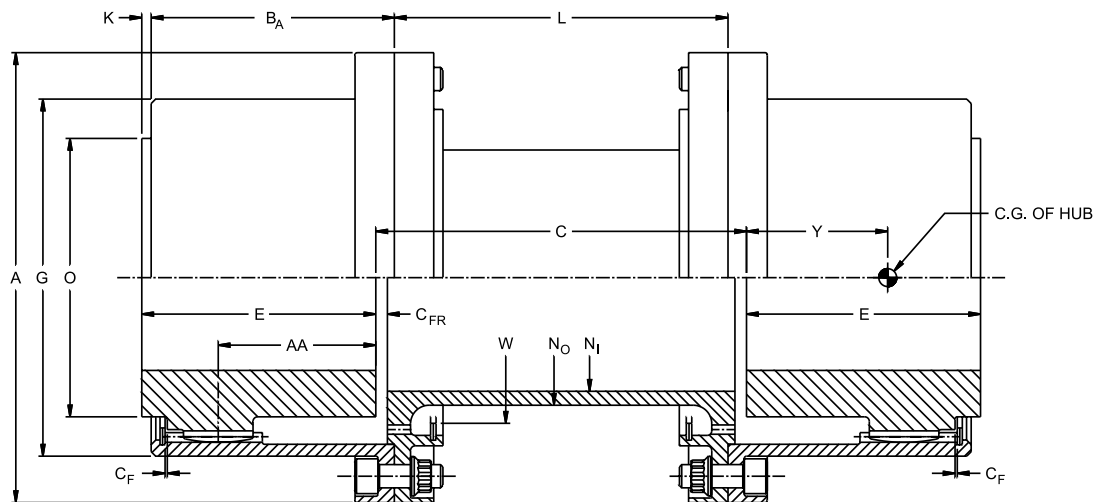
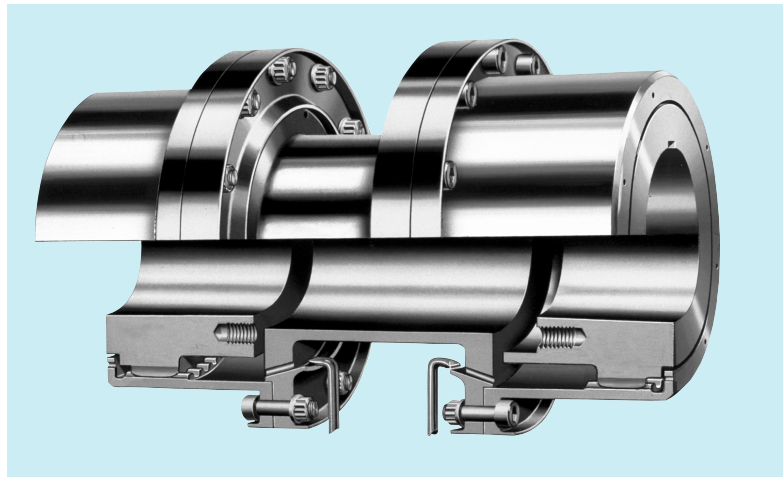

SIZE	DIMENSIONS (mm)																	SIZE
	A	C	C _A	C _F	C _{FR}	G	L	N _I	N _O	O	W	LONG HUB						
												BORE	E	B	BA	A-A	Y	
1 1/4	104	127	5	0.8	3.2	78	117	38	44	57	60	38	48	222	53	33	25	1 1/4
1 1/2	127	127	6	1.6	3.2	101	116	48	57	76	81	51	62	251	67	43	62	1 1/2
2	154	127	6	1.6	4.0	122	114	67	76	95	100	64	77	281	83	54	40	2
2 1/2	178	127	7	2.4	4.8	144	113	85	95	114	121	76	91	310	98	64	48	2 1/2
3	208	127	7	2.4	4.8	169	113	103	114	133	141	89	106	340	114	76	56	3
3 1/2	237	178	8	3.2	4.8	190	162	121	133	152	162	102	121	419	129	84	60	3 1/2
4	267	178	10	3.2	6.4	216	159	140	152	171	183	114	135	448	144	96	69	4
4 1/2	294	178	10	4.0	6.4	242	159	157	171	191	203	127	153	484	163	109	80	4 1/2
5	351	254	11	4.0	8.0	286	232	192	191	229	244	152	188	630	199	136	99	5
6	411	254	13	4.8	9.6	335	229	229	229	267	283	178	221	695	233	164	116	6
7	464	305	13	4.8	9.6	387	279	264	267	305	327	203	247	799	260	188	130	7

Contact KOP-FLEX for larger sizes.
See page 30 for maximum bore capacity.

ACCS/RMD Gear Coupling Continuous Lubrication Sizes #1 1/2 - #7

ACCS/RMD nomenclature denotes:
AC—Series AC coupling, C—oil
introduced thru the spacer, and
RM—reduced moment, D—Damless.

- Lightweight
- Damless

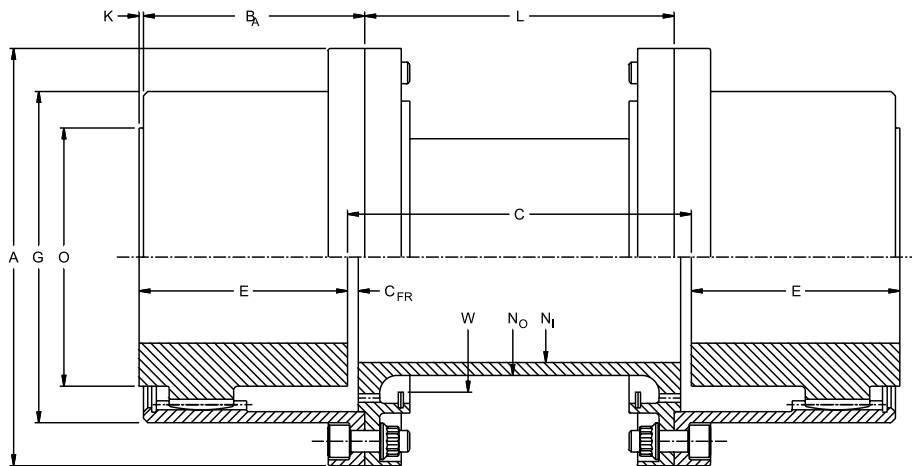
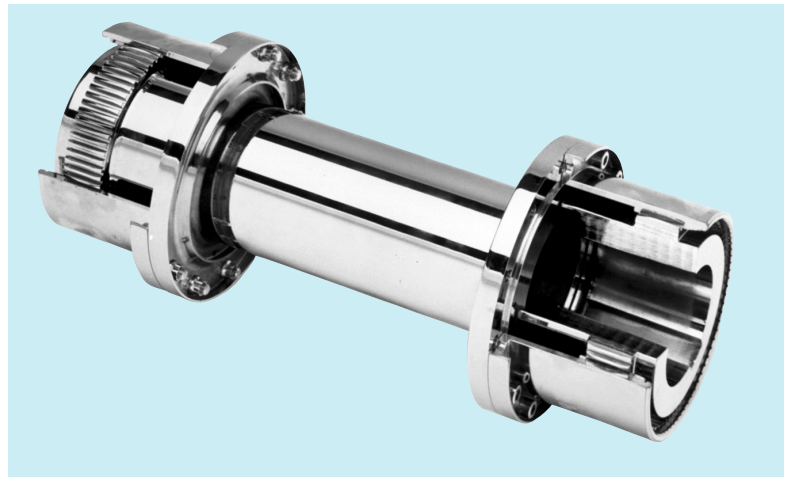

Coupling Size	A (mm)	BA (mm)	"Std" C Shaft Sep. (mm)	C _{FR} (mm)	E Fit Length (mm)	G (mm)	K (mm)	"Std" L Spacer Length (mm)	W Oil Inlet (mm)	N _O (mm)	N _I (mm)
1.5	127	66	127	3.1	62	101	1.5	116	81	57	48
2	154	82	127	4.1	77	122	1.5	114	100	76	67
2.5	178	97	127	4.8	91	145	1.5	113	121	95	85
3	208	108	127	4.8	106	169	4.1	116	141	114	103
3.5	236	124	178	4.8	121	190	4.8	162	162	133	121
4	167	141	178	6.4	165	216	3.1	159	183	152	140
4.5	294	160	178	6.4	153	242	3.1	159	203	171	157
5	351	194	254	7.9	188	286	5.6	232	244	210	192
6	411	232	254	9.7	221	335	1.5	229	282	248	229
7	464	259	305	9.7	249	387	3.1	279	327	286	264

Contact KOP-FLEX for larger sizes.
See page 30 for maximum bore capacity.
Damless couplings require increased lube flow. Consult KOP-FLEX for recommendations.

ACPL Gear Coupling Continuous Lubrication Sizes #1 1/4 - #7

The ACPL nomenclature denotes:
AC Series AC coupling, PL—packed
lubrication.

- Packed lube w/KHP Grease
- Low to moderate speed range
- No oil nozzels

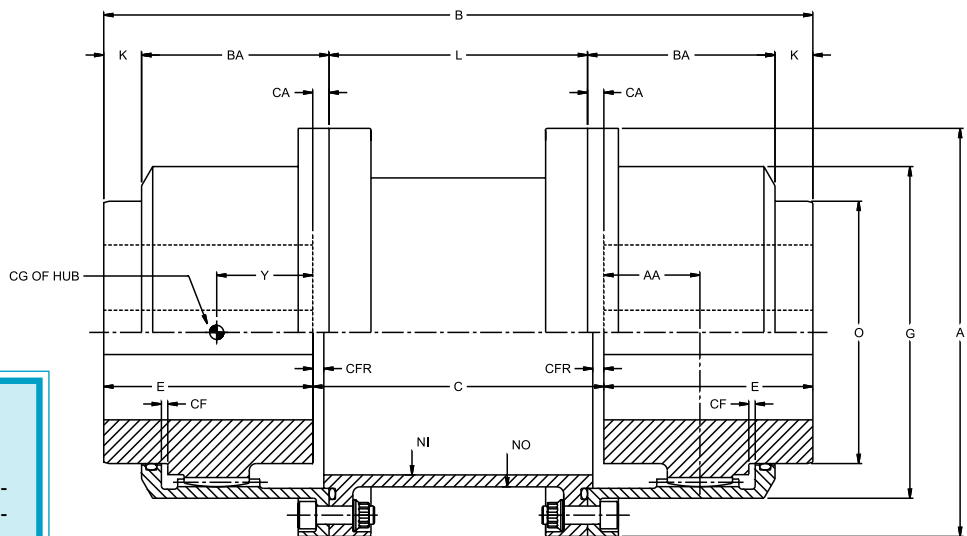
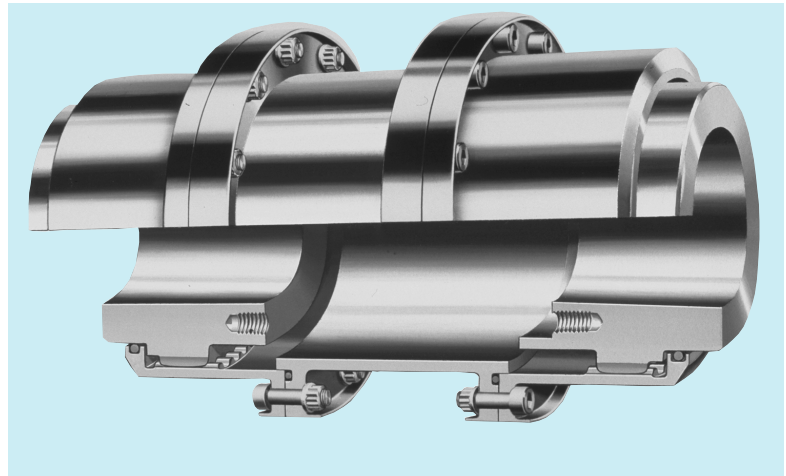

KOP-FLEX Coupling Greases

KOP-FLEX offers greases specifically designed for use in coupling applications. To ensure proper lubrication and long service life, use KOP-FLEX KSG Standard Coupling Grease, or KHP High Performance Coupling Grease. See page 63 for detailed specifications.

SIZE	DIMENSIONS (mm)													MAXIMUM BORE					SIZE
	A	B _A	C	C _A	C _F	C _{FR}	G	L	N _I	N _O	O	A-A	BORE	E	B	K	Y		
	1 1/4	104	40	127	5	0.8	3.2	78	117	63	69	57	18	38	48	222	12	23	
1 1/2	127	51	127	6	1.6	3.2	101	116	84	90	76	22	51	62	251	17	30	1 1/2	
2	154	66	127	6	1.6	4.0	122	114	103	112	95	32	64	77	281	17	38	2	
2 1/2	178	82	127	7	2.4	4.8	144	113	124	135	114	42	76	91	310	17	45	2 1/2	
3	208	95	127	7	2.4	4.8	169	113	145	156	133	50	89	106	340	18	53	3	
3 1/2	237	111	178	8	3.2	4.8	190	162	165	179	152	60	102	121	419	17	58	3 1/2	
4	267	125	178	10	3.2	6.4	216	159	187	202	171	67	114	135	448	19	67	4	
4 1/2	294	140	178	10	4.0	6.4	242	159	209	225	191	77	127	153	484	23	76	4 1/2	
5	351	160	254	11	4.0	8.0	286	232	251	279	229	88	152	188	630	40	94	5	
6	411	193	254	13	4.8	9.6	335	229	289	313	267	116	178	221	695	40	111	6	
7	464	223	305	13	4.8	9.6	387	279	337	362	305	143	203	247	799	37	125	7	

Contact KOP-FLEX for larger sizes.

ACCM Gear Coupling Continuous Lubrication Sizes #1 1/4 - #7

The ACCM nomenclature denotes:
AC Series AC coupling, C-
continuous oil lubrication, M-Marine
Style.

- Marine Style
- Replace flex section without removing hubs

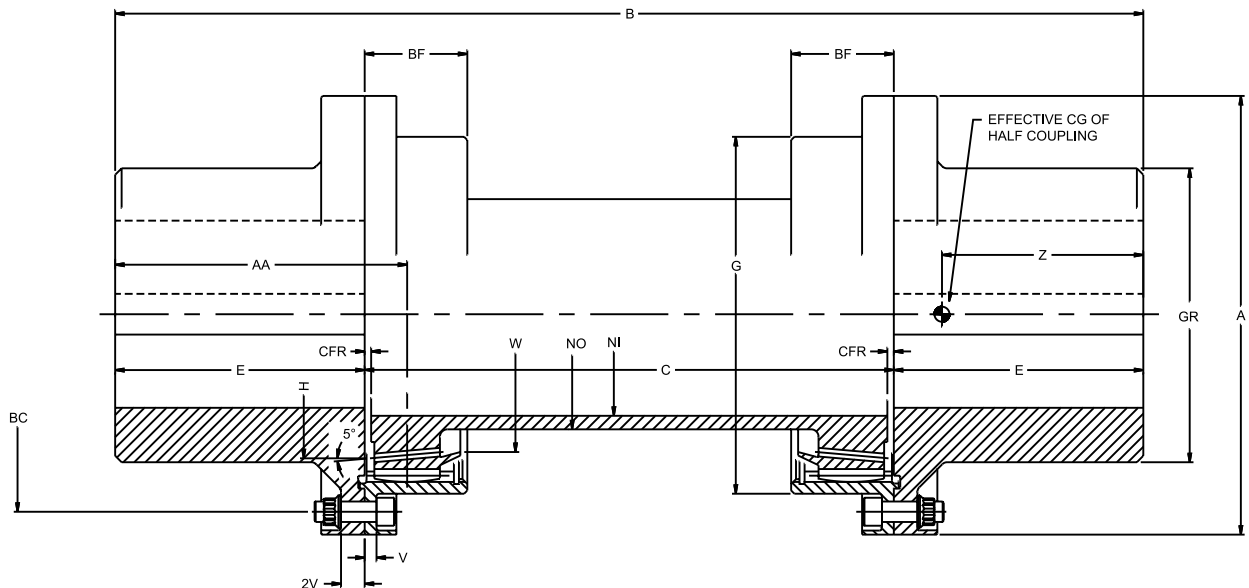
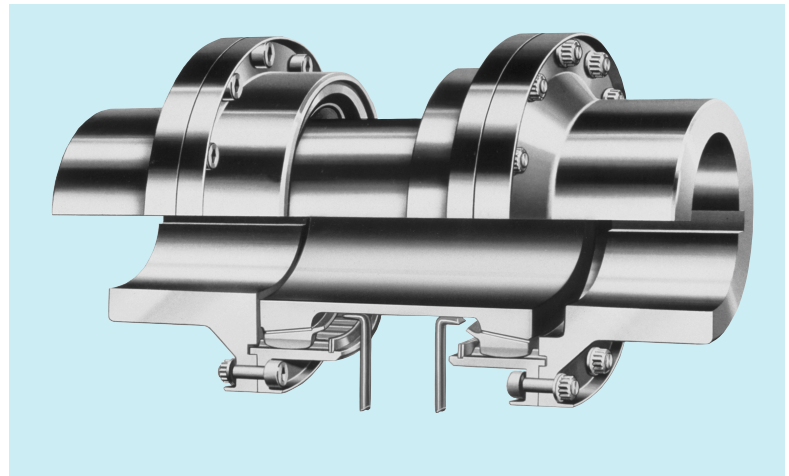

SIZE	A	B _C	B _F	C	C _{FR}	G	N _I	N _O	V	W	SHORT RIGID HUB						LONG RIGID HUB					
											BORE	E	B	G _R	A-A	Y	BORE	E	B	G _R	A-A	Y
1 1/2	127	112	31	127	3.1	79	43	54	4	73	38	48	222	57	61	40	64	62	251	95	75	40
2	154	136	39	127	2.4	125	59	71	6	90	51	62	251	76	78	49	79	77	281	114	93	49
2 1/2	178	159	44	127	3.2	144	83	94	6	113	64	77	281	95	96	57	98	91	310	138	110	56
3	208	186	49	127	3.2	169	97	110	6	130	76	91	210	114	112	66	114	106	340	162	127	64
3 1/2	237	83	57	178	4.0	190	111	125	6	148	89	106	391	133	131	76	124	121	419	181	145	58
4	267	239	61	178	4.0	216	122	140	7	167	102	121	419	152	148	85	143	135	448	205	162	82
4 1/2	294	265	73	178	4.8	242	137	156	7	184	114	135	448	171	167	94	165	153	484	233	198	91
5	351	315	83	254	4.8	286	173	194	9	224	127	153	560	191	191	110	171	185	624	276	222	110
6	411	362	98	254	6.4	338	197	222	10	254	152	185	624	229	228	132	225	215	684	324	258	129
7	464	421	105	305	6.4	387	241	267	10	302	178	215	735	267	261	147	260	248	799	371	293	144

Contact KOP-FLEX for larger sizes.

SELECTION EXAMPLE

EXAMPLE: Steam Turbine/Centrifugal Compressor (API 671 required; 1.75 application factor; reduced moment required on compressor shaft; 1/4° angular misalignment capacity required)

Turbine Shaft — 6.0" tapered, keyless hydraulic
Compressor shaft — 6" tapered, keyless hydraulic
24" shaft separation

Normal load: 42000 HP at 6000 RPM

Continuous torque capacity required (lb-in.)

$42000 \times 63025 \times 1.75 = 772100 \text{ lb-in.}$

6000

SELECTION: #5.0 ACCS/RM

CLASS "AC" COUPLING SELECTION DATA

Coupling Size	Max. Bore Capacity (mm)	Max. Continuous Rating (kNm)	Peak Rating (kNm)	Maximum Speed (rpm)
1.5	51	3.84	5.09	34,400
2	64	7.55	10.1	28,400
2.5	76	13.1	18.1	24,600
3	89	20.7	28.3	21,000
3.5	102	31.0	42.4	18,500
4	114	44.2	62.2	16,400
4.5	127	60.5	84.8	14,900
5	152	105	141	12,500
6	178	133	226	10,600
7	203	166	339	9,420

Notes: (1) Max. Continuous Rating based on Nitrided gearing.

When Ordering, specify the following information:

- 1) Quantity and delivery requirements.
- 2) Shaft or bore sizes, keyway dimensions.
- 3) Load-horsepower and/or torque at a specific rpm. State normal (steady-state) and peak (transient) conditions.
- 4) Speed-minimum, normal maximum.
- 5) application - type of driving and driven equipment.
- 6) Space limitations-envelope dimensions, and shaft separations.
- 7) Unusual misalignment conditions, normal and maximum.
- 8) Modifications and special requirements.
- 9) Unusual operating conditions-ambient temperature and atmosphere.