

Link-Belt® Bearings

Link-Belt®

Air Handling Bearing Capabilities

Ball Bearings

Standard Duty
Medium Duty
Heavy Duty

Spherical Roller Bearings

Collar Mounted
Adapter Mounted

Rexnord
|||||

An Invensys company

SAF Spherical Roller Bearing Units

Adapter Mounted

Fixed and Expansion

Contact and Clearance Seals

All Caps Have Four Grade-5 Bolts

Extra strength for up lift loads

Cap and Base Matched and Marked

Ensures machined pairs stay together during installation



H-7 Bearing Fit in Housing

Close bearing-housing tolerance critical for fans or out-of-balance loads

Precision Dowel Holes to Position Unit

Makes mounting or remounting fool proof

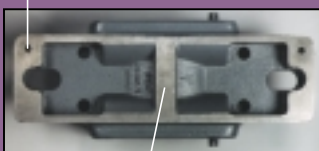

Center Support Bar in Base

Extra support for shock loads

See Link-Belt Catalog 3000 or Brochure 3032 for details.

Standard Features of the New Housing Design

Dimpled Flats for Bearing Monitor Probes

Determines exact location for probe field installation or have drilled to your specifications.

Standard Units Primed and Finish Coated

Special coatings available for severe environments.

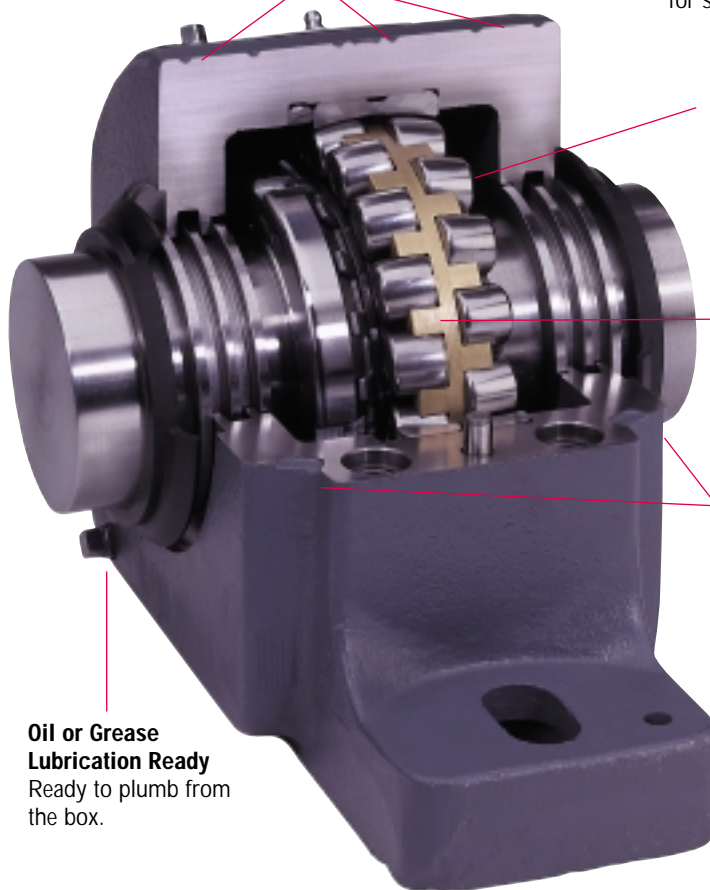

High-Capacity "E" Spherical Bearing

Provides maximum capacity for long service life.

Machined Bronze Retainer

Ensures quiet operation.

Pry Slots for Easy Cap Removal

Oil or Grease Lubrication Ready

Ready to plumb from the box.

SAF Block Interchange

Fits all current SAF22500 applications.

Metal Triple-Ring R Clearance Seal

This industry standard seal provides a labyrinth grease chamber between the housing grooves and the seal rings. Operates at high speed; good for moderate dust, dirt or moisture.

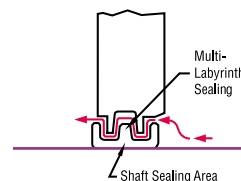

NEW D5 PenTac™ 5-Point Contact Sealing System

Rugged contact lip seal, molded on a Kevlar® body, rotates with the shaft. The PenTac seal acts as a flinger, keeping debris away from the seal area, and provides five seal points:

- 1 – Seals shaft
- 2 – Seals housing
- 3 – Creates a grease chamber to prevent bearing contamination
- 4 – Acts as a flinger
- 5 – Grease chambers created by multi-labyrinth chamber

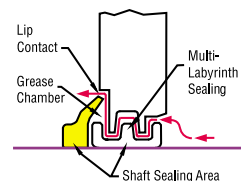
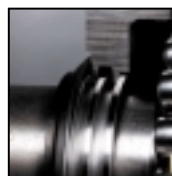

Ball Bearings

Standard Duty

Medium Duty

Contact and Clearance Seals

Three Locking Types

Link-Belt Bearings offer the most complete line of high-quality ball and roller bearings available for the Industrial and Commercial Air Handling Industries.

Available from Rexnord Warehouses and Industrial Distributors worldwide and backed by an experienced staff of application engineers.

Three Locking Types

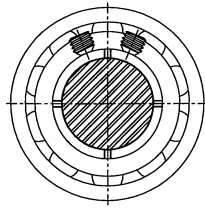

Centrik-Lok®
Available on MB brand units. Inner Ring is slotted in four places. Two collar mounted set screws at 45 degrees develop a clamping force which centers the shaft.

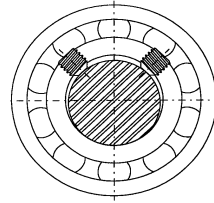

Set Screw Locking
Available on Link-Belt and MB units. Two set screws hold shaft. 90-degree set screw angle maximizes holding power and minimizes inner ring distortion.

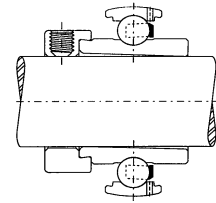

Eccentric Cam Locking
Available on Link-Belt units. Twisting the collar internal eccentric engages the inner ring cam, locking the assembly to the shaft.

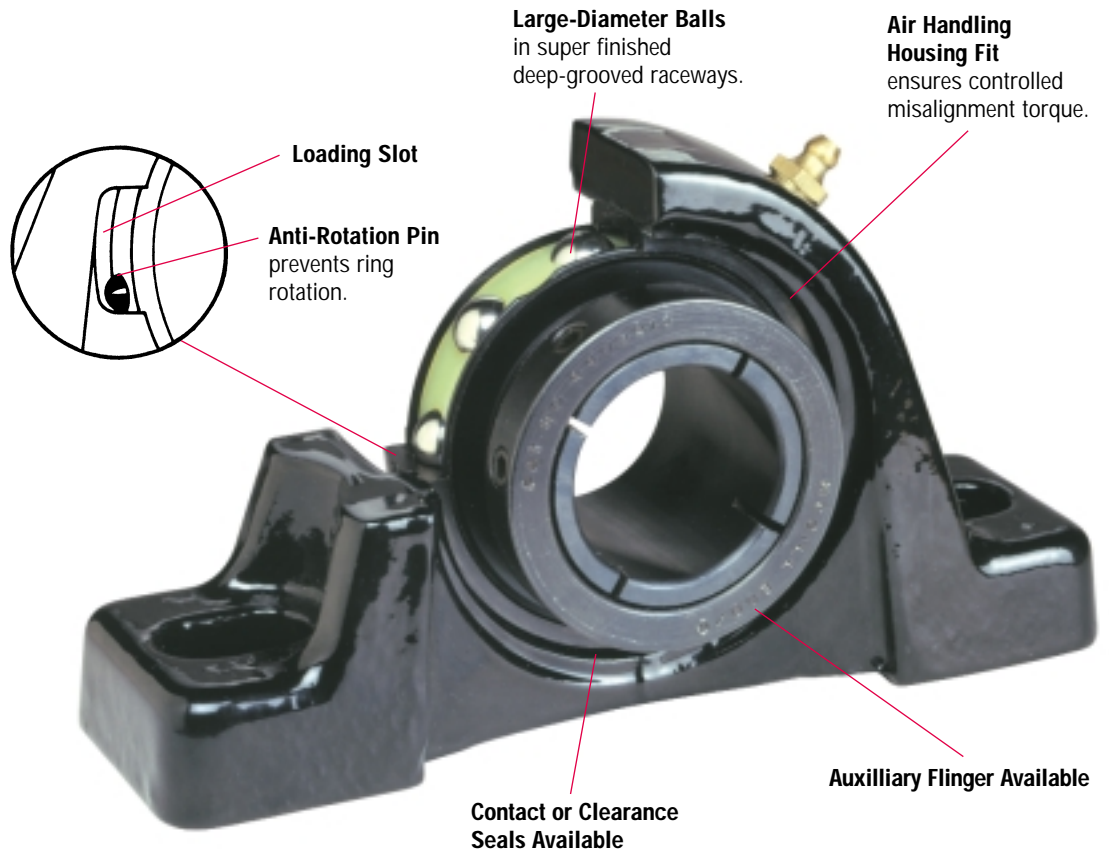

BRAND	MB				LINK-BELT	
	SET SCREW LOCK		CENTRIK-LOK		SET SCREW LOCK	ECCENTRIC CAM LOCK
DUTY	STD DUTY	MED DUTY	STD DUTY	MED DUTY	STD DUTY	STD DUTY
PILLOW BLOCK	C25	C35	KC45	KC55	P3U200N	P3Y200N
2-BOLT FLANGE	FC2-25	FC2-C35	KFC2-45	KFC2-55	FX3U200N	FX3Y200N
4-BOLT FLANGE	FC4-25	FC4-C35	KFC4-45	KFC4-55	F3U200N	F3Y200N

Pillow Block, 2- and 4-bolt Flange Units available in 1/2" through 2-7/16" shaft sizes.

See Link-Belt Catalog 3000 or MB Catalog 3050 for details.

Heavy-Duty Ball Bearings

Set Screw Mounted
 Adapter Mounted
 Fixed and Expansion
 Contact and Clearance Seals

Fixed and expansion units allow for thermal expansion. Expansion unit's cartridge design provides positive movement limited by locking plug in slotted hole.

Set Screw Collar Mounting

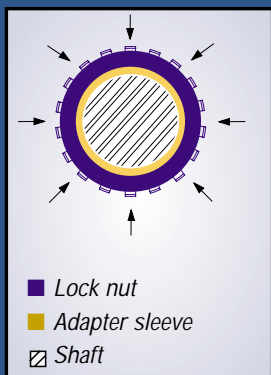
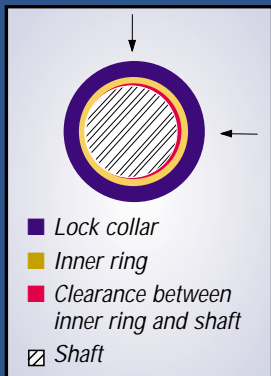

See Link-Belt Catalog 3000 or Brochure 3014 for details.

Pre-Lubricated and Relubricatable Bearings with highly compatible Lithium complex grease extends temperature range and bearing life...minimizing maintenance.

Super-Finished Bearing Races for better lubrication, higher speed, long life and *quiet* operation.

Alignable, Precision, Deep-Groove Ball Bearing of quality alloy bearing steel provides high capacity for radial and thrust loads.

Anti-Rotation Pin prevents ring rotation on unbalanced loads. Precision housing machining ensures controlled bearing misalignment torque.

Spring-Locking Collar and Two Set Screws lock wide inner ring securely to shaft for rotation in either direction or reversing applications.

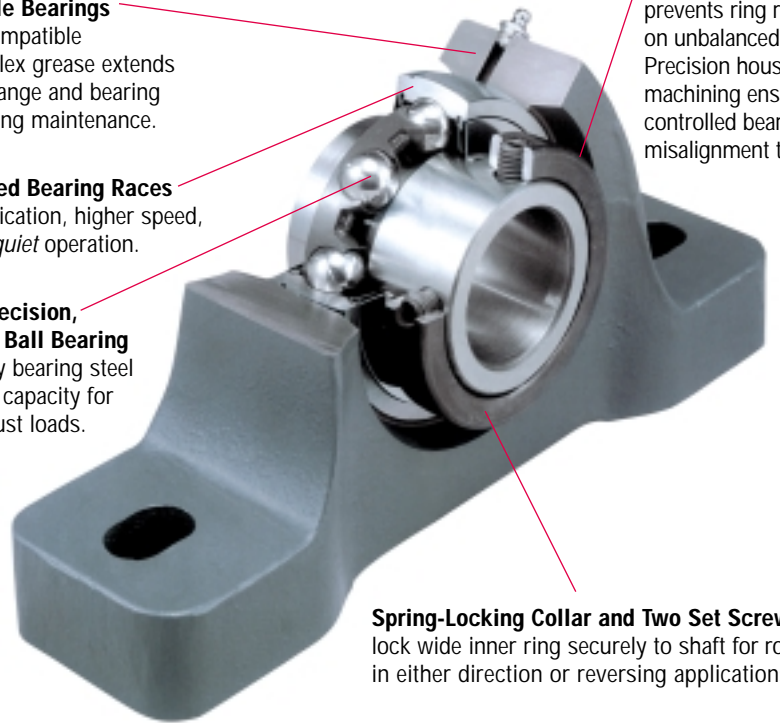

NEW P-U3K00 Adapter Mounted Heavy-Duty Ball Bearing



Adapter Mounting for Maximum Holding Power and Concentric Shaft Fit

Easy-to-mount, tapered adapter provides maximum clamping force using commercial shafting tolerances, automatically centering the shaft for concentric fit, which maximizes shaft-bearing balance, and extends bearing life.

Link-Belt Series 300 Bearings are designed to ISO "03" ball bearing boundary plans, instead of smaller "02" boundary plans used for normal-duty and medium-duty bearings. Benefits include higher load ratings and dramatically longer life.

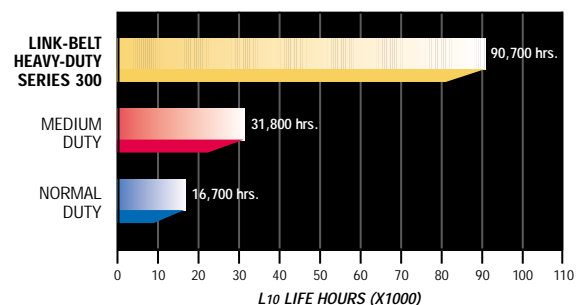

Comparison of L10 life hours for heavy-, medium-, and normal-duty ball bearing units @ 1800 RPM & 500 lbs. radial load (1-11/16" size).

Collar Mounted Roller Bearings

Set Screw Mounted
Adapter Mounted
Fixed and Expansion
Contact and
Clearance Seals

B22400 Series

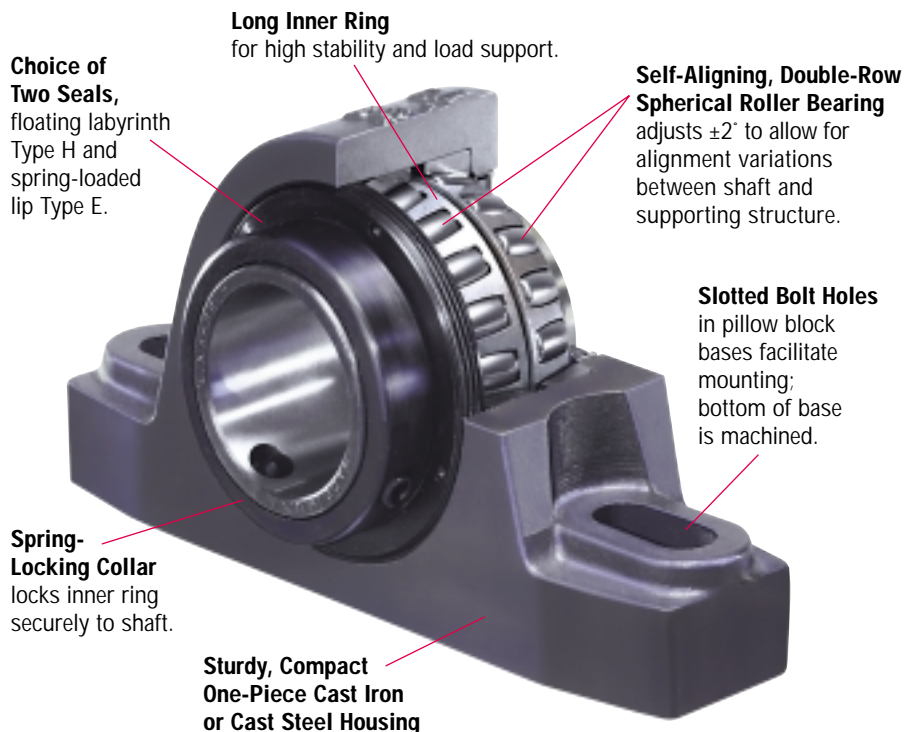

Type H Clearance Seal

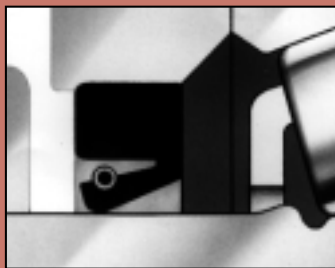

Type E Contact Seal

B22600 Series

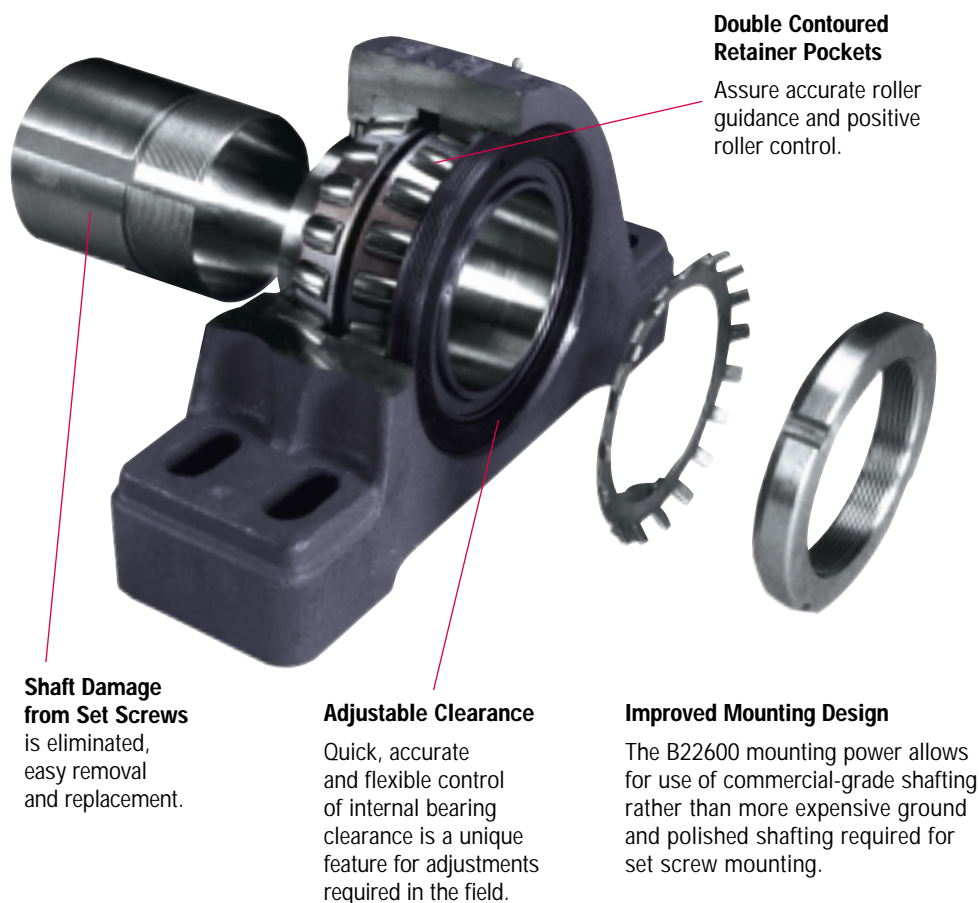

See Link-Belt Catalog 3000
or Brochure 3001 for details.

Selection and Maintenance Tips

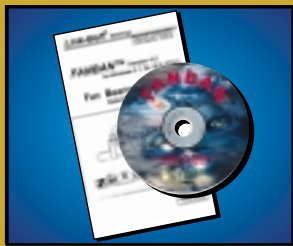

FANBAN

Link-Belt's proprietary FANBAN bearing selection software can quickly compare various bearing choices and will provide documentation for engineering records or sales proposals. Software provides load analysis, L_{10} life estimates, shaft fitting practices, lubrication recommendations, thermal analysis and bearing frequency information.



CadCat

Assists drafting and detailing bearing applications with dimensionally accurate bearing drawings in AutoCad formats.



Bearing Sensors – Speed, Vibration and Temperature

Integral bearing sensors for SAF units are easy to install. Explosion-proof NEMA 4 mounted. Allows continuous monitoring of critical equipment using a PLC.



Mounting Video

A 25-minute VHS video demonstrates proper mounting techniques for ball and roller bearings to ensure problem-free operation.

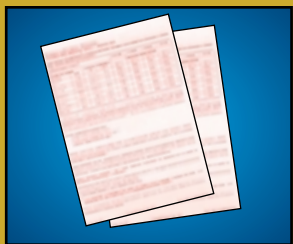

Lubrication Schedules

Self-adhesive lubrication decals are available for mounting on critical fan and blower equipment to ensure proper maintenance.



Rexnord Corporation
Link-Belt Bearing Division
7601 Rockville Road
Indianapolis, Indiana 46214
PH: 317/273-5500
FAX: 317/273-5620
www.rexnord.com

