

Nice Ball Bearings



NICE®

NICE

In 1902, William Nice founded one of the first “anti-friction” bearing manufacturers. Starting with unground ball bearing types and progressing into fully ground types, NICE today produces a complete line of precision ground, semi-ground and, unground bearings and bearing assemblies. NICE is a leading manufacturer of high quality inch series and specialty ball bearings for the automotive, agricultural, lawn equipment, semiconductor, medical and material handling industries.

NICE Precision Ground Product

NICE Ball Bearings produces a complete line of high quality, competitively priced precision ground and semi-ground ball bearings. The standard bearings are manufactured in easy to use inch dimensions and are recommended for medium loads

and speeds up to 5000 rpm. They are available with nylon retainers as standard. Steel and stainless steel retainers for many sizes can be supplied as an option. The precision ground products are also available in a variety of seal or shield combinations. Special needs—including non-standard or metric dimensions and bearings made of various specialty steels—can also be supplied.

NICE Unground Industrial Product

NICE Ball Bearings produces a complete line of unground radial, thrust and combination radial and thrust ball bearings for applications where the speeds are low and the precision of a ground bearing is neither required nor cost effective. These products are full ball complement designs featuring unitized assembly for ease of installation.

The NICE Advantage

U. S. Made - Manufactured in the United States, NICE products consistently offer high quality, fast delivery and low freight costs.

Technical Support - A full staff of application and design engineers offers fast, efficient response to technical questions and solutions based new or special product designs.

High Quality - NICE manufacturing facilities operate under a total quality system utilizing statistical process control, resulting in the consistent supply of high quality products.

Superior Availability & Fill Rates - Utilization of a “make to forecast” planning process and domestic manufacture results in short lead times, high reliability and low freight costs.

Sales Support - Sold exclusively by SKF/MRC, with sales offices located nationwide.

TABLE of Contents



Product Selection Guide	4	SELECTION GUIDE
Product Features	5	PRODUCT FEATURES
1600 Series Precision Ground Radial Bearings	6-7	1600 SERIES
3000 Series Semi-Ground Radial Bearings	8-9	3000 SERIES
6900 Series Semi-Ground Radial Bearings, Extended Inner with Flanged Housing	10-11	6900 SERIES
7500 Series Heavy Duty Precision Ground Radial Bearings	12-13	7500 SERIES
7600 Series Heavy Duty Precision Ground Radial Bearings with Extended Inner Ring	14-15	7600 SERIES
400 Series Single Row Unground Radial Bearings	16-17	400 SERIES
5000 Series Single Row Unground Flanged Radial Bearings	18-19	5000 SERIES
500 Series Single Row Unground Combination Radial and Thrust Bearings	20-21	500 SERIES
600 Series Unground Thrust Bearings	22-23	600 SERIES
Engineering Data	24-27	ENG. DATA
Specials and Applications	28-31	SPECIALS & APPS

PRODUCT Selection Guide

NICE Ball Bearings, Inc. produces a full line of ground, semi-ground, and unground bearing assemblies. To choose the exact bearing you need, start with the Nice line of standard inch-dimension, radial, angular contact and thrust ball bearings. Standard series bearings can be customized to include many features that can satisfy the demands of many special applications. They are available with special bores, modified outer ring shapes, extended inner rings, locking devices, and flanged housings. Standards can be ordered sealed, shielded, or open, and are offered in ground and semi-ground grades to deliver the most cost effective solution for your application.

If you are now designing with only ABEC-1 level or higher bearings, chances are there may be a more economical solution to your application. A Nice application engineer can help you determine the exact precision your design requires, and show you how to take advantage of the savings, selection and special features available in our standard series. Even when a standard isn't the answer, our engineers can deliver an economical, modified standard design that is "fit for purpose."

Nice Standard Product Line

Class	Series	Type	Ground Surfaces	Bore Range
Ground	1600	(Retainer) Radial	Raceways	3/16"-1 5/16"
	7500	Radial	Bore, O.D., Faces	1/2"-1 1/4"
	7600	Radial Extended Inner		
Semi-Ground	6900	Radial Flanged Extended Inner	Raceways, O.D., Faces	3/8"-1"
	3000	(Retainer) Radial	Outer Raceways, O.D., Faces	3/16"-1"
Unground	400	(Full Complement) Radial		3/16"-2"
	500	Radial/Thrust		1/4"-2 1/4"
	600	Thrust		1/4"-1 1/2"
Modified Standards and Specials	All	Radial Retainer and Full Types Thrust Radial/Thrust	Any Combination	3/16"-2"

DESIGN

Three basic ball bearing types are illustrated to assist in proper design selection

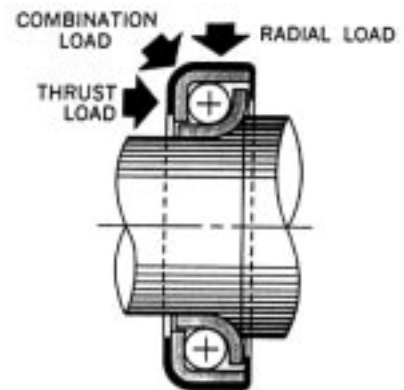
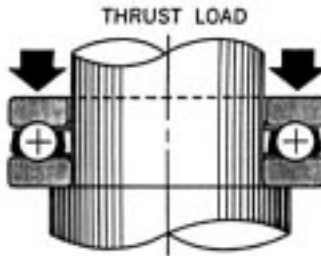
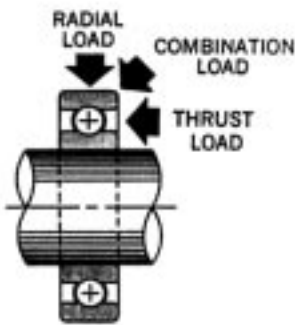

- 1.** Radial bearings are designed primarily to carry loads perpendicular to the axis of the bearing bore. They will also accommodate limited thrust loading or a combination radial and thrust load.
- 2.** Thrust bearings carry loads applied parallel to the axis of the bearing bore. They are not designed to accommodate radial loads.
- 3.** Combination radial and thrust bearings are designed for simultaneously applied thrust and radial loads. Combination assemblies will also carry pure thrust loading; however, they are not recommended for straight radial loads unless provisions are made to keep the inner rings and outer rings in proper contact with the balls.

Many sizes and types of the three basic designs illustrated are available for selection from this catalog. However, if you have an unusual application problem, NICE field and factory engineers will be glad to give you the benefit of their specialized training and broad practical experience.

PRODUCT Features

Modified Standards

Modified standard bearings feature a standard cage and ball complement or a full ball complement, with custom engineered modifications to the other bearing components. The exact inner and outer ring dimensions and designs can be combined with a wide range of seals, shields, special greases, special materials and special finishes.

Modification instead of full customizing gives the user the benefits of a fully custom bearing with lower costs and faster delivery times. Prototype lots are readily affordable and available for testing and evaluation.

Modified standard bearings offer the greatest value for your bearing dollar by offering custom bearings at standard prices. Here are some of the many ways we can modify standard ball bearings to fit any application.

Inner Rings

A variety of bore shapes and sizes can be custom engineered to simplify mounting procedures, reduce assembly costs, and allow misalignment.

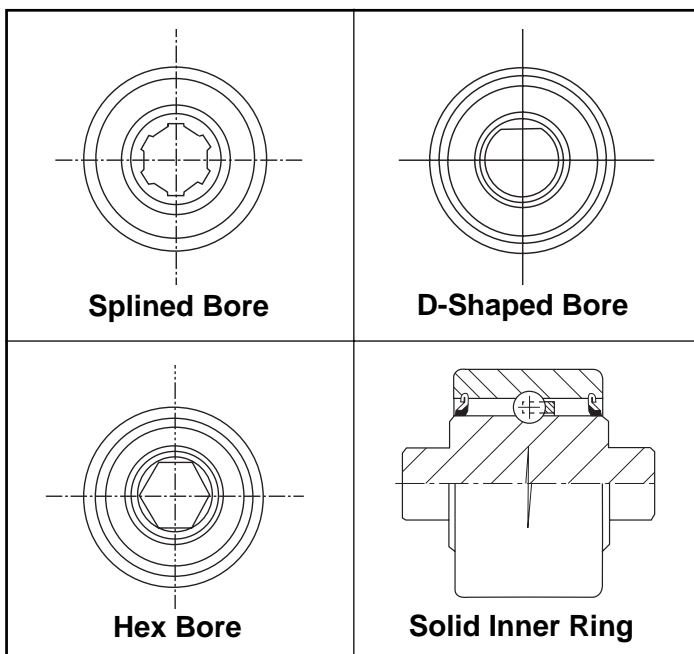

Outer Rings

Outer rings can be custom engineered to include milled slots, snap rings, track grooves, or even a variety of plastic tires. Add to this flanges or pulley units and a variety of custom solutions are readily available.

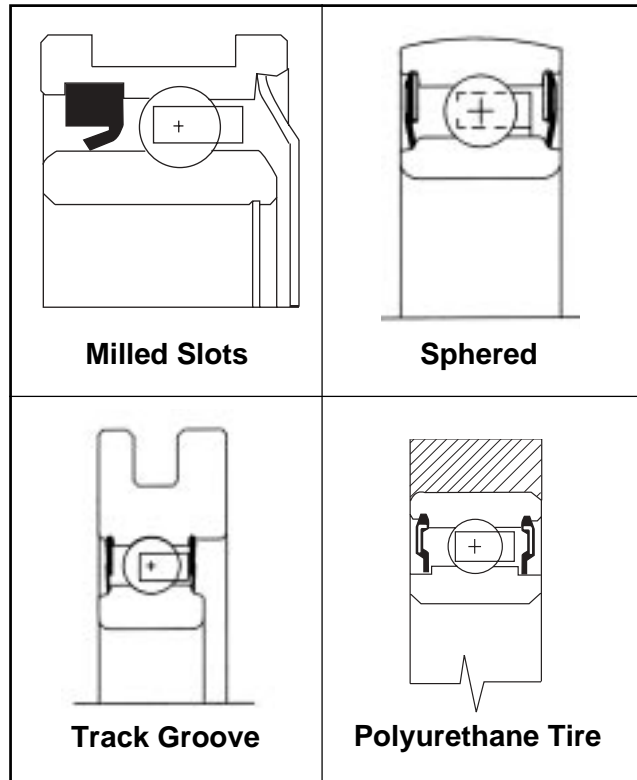

Materials and Finishes

Nice has extensive experience with a variety of special materials and finishes developed to stand up to various contaminants or to take unusually hard wear. Nice bearings are made from steels of various chemical compositions. Carburizing grades are case hardened to desired depths and hardness values for wear and breakdown resistance. High carbon chrome alloy steels are through hardened for high wear and fatigue resistance. Stainless steels are available for corrosion resistance and food service applications. Special platings and finishes such as zinc, black oxide, and thin dense chrome are available for special applications. Nice application engineers can assist in bearing selection for special material applications.

NICE

1600 Series Precision Ground Radial Bearings

- **PRECISION GROUND ON ALL CONTACT SURFACES**
- **EASY TO USE INCH DIMENSIONS**
- **MEDIUM LOADS**
- **MAX SPEED RANGE - 5000 - 6000 RPM**
- **THROUGH HARDENED BEARING STEEL**
- **NYLON RETAINER STANDARD**
- **GREASED, DOUBLE SEALED OR DOUBLE SHIELDED STANDARD**
- **AVAILABLE SINGLE SEALED OR SINGLE SHIELDED, OPEN, AND WITH OR WITHOUT GREASE**

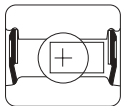
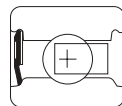
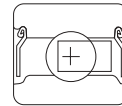
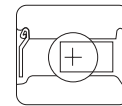
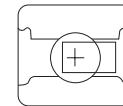

BEARING NUMBER					PRINCIPAL DIMENSIONS	
					BORE d (in) +.0000/- .0005	O.D. D (in) +.0000/- .0005
DOUBLE SEAL	SINGLE SEAL	DOUBLE SHIELD	SINGLE SHIELD	OPEN		
④ 1602DC	1602SC	1602DS	1602SS	1602NS	0.2500	0.6875
1603DC	1603SC	1603DS	1603SS	1603NS	0.3125	0.8750
1604DC	1604SC	1604DS	1604SS	1604NS	0.3750	0.8750
1605DC	1605SC	1605DS	1605SS	1605NS	0.3125	0.9063
1606DC	1606SC	1606DS	1606SS	1606NS	0.3750	0.9063
1607DC	1607SC	1607DS	1607SS	1607NS	0.4375	0.9063
1614DC	1614SC	1614DS	1614SS	1614NS	0.3750	1.1250
1615DC	1615SC	1615DS	1615SS	1615NS	0.4375	1.1250
1616DC	1616SC	1616DS	1616SS	1616NS	0.5000	1.1250
1620DC	1620SC	1620DS	1620SS	1620NS	0.4375	1.3750
1621DC	1621SC	1621DS	1621SS	1621NS	0.5000	1.3750
1623DC	1623SC	1623DS	1623SS	1623NS	0.6250	1.3750
1628DC	1628SC	1628DS	1628SS	1628NS	0.6250	1.6250
1630DC	1630SC	1630DS	1630SS	1630NS	0.7500	1.6250
1633DC	1633SC	1633DS	1633SS	1633NS	0.6250	1.7500
1635DC	1635SC	1635DS	1635SS	1635NS	0.7500	1.7500
⑤ 1638DC	1638SC	1638DS	1638SS	1638NS	0.7500	2.0000
⑤ 1640DC	1640SC	1640DS	1640SS	1640NS	0.8750	2.0000
⑤ 1641DC	1641SC	1641DS	1641SS	1641NS	1.0000	2.0000
④ ⑤ 1652DC	1652SC	1652DS	1652SS	1652NS	1.1250	2.5000
④ ⑤ 1654DC	1654SC	1654DS	1654SS	1654NS	1.2500	2.5000
④ ⑤ 1657DC	1657SC	1657DS	1657SS	1657NS	1.2500	2.5625

- ① Width for sealed versions = 0.3125
- ② Width for sealed versions = 0.3438
- ③ Weights given are for greased and sealed versions
- ④ Multi-part seals
- ⑤ O.D. Tolerance +.0000/- .0006

1600 Series Precision Ground Radial Bearings

Precision ground 1600 series bearings are specially designed to provide a line of low cost yet high quality bearings for adaptation to a majority of precision bearing applications. They are made in easy to use inch dimensions and are recommended for medium loads and for maximum speeds in the range of 5000 rpm.

The 1600 series bearings are precision ground on all surfaces with exceptional care given to the ball grooves. Careful heat treatment provides a uniform and exact degree of hardness for maximum life. A ball retainer, or separator, is used to increase the range of allowable speeds by reducing ball-to-ball contact friction. The 1600 series radial bearings are available open, single or doubled shielded, or single or double sealed. Double sealed and double shielded bearings are supplied grease packed as standard. Open and single closure bearings can be supplied greased on request.

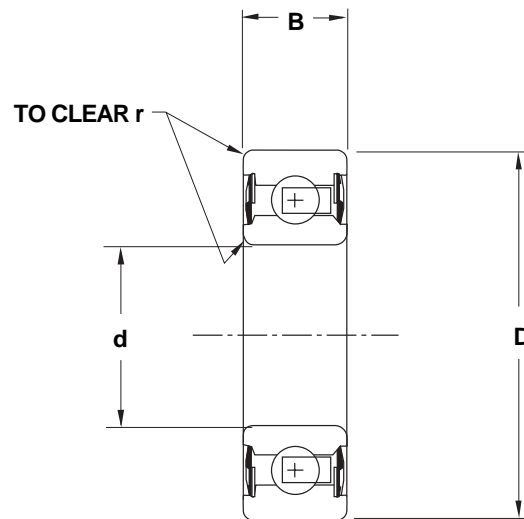

	BASIC LOAD RATINGS		WEIGHT	ABUTMENT AND FILLET DIMENSIONS		
WIDTH B (in) +.0000/-.005	DYNAMIC C (lb)	STATIC C ₀ (lb)	W ³ (lb)	d _a min (in)	D _a max (in)	r max (in)
0.2500 ①	511	170	0.02	0.330	0.614	0.012
0.2813 ②	644	255	0.03	0.474	0.778	0.012
0.2813 ②	644	255	0.03	0.474	0.778	0.015
0.3125	698	300	0.04	0.503	0.778	0.012
0.3125	698	300	0.04	0.517	0.778	0.015
0.3125	698	300	0.03	0.517	0.778	0.015
0.3750	1200	475	0.06	0.595	1.014	0.025
0.3750	1200	475	0.06	0.622	1.014	0.025
0.3750	1200	475	0.06	0.622	1.014	0.025
0.4375	1878	850	0.12	0.658	1.203	0.025
0.4375	1878	850	0.11	0.720	1.203	0.025
0.4375	1878	850	0.10	0.753	1.203	0.025
0.5000	2600	1010	0.18	0.845	1.446	0.025
0.5000	2600	1010	0.16	0.965	1.446	0.025
0.5000	2600	1025	0.22	0.845	1.530	0.025
0.5000	2600	1025	0.20	0.965	1.530	0.025
0.5625	2967	1350	0.32	0.988	1.760	0.035
0.5625	2967	1350	0.26	1.113	1.760	0.035
0.5625	2967	1350	0.38	1.197	1.760	0.035
0.6250	3864	2120	0.46	1.375	2.244	0.035
0.6250	3864	2120	0.51	1.500	2.244	0.035
0.6875	5360	2620	0.57	1.500	2.314	0.035

3000 Series Semi-Ground Radial Bearings

- **PRECISION GROUND ON ALL CONTACT SURFACES EXCEPT BORE**
- **EASY TO USE INCH DIMENSIONS**
- **ECONOMICAL BEARING FOR LIGHTER LOADS THAN THE 1600 SERIES**
- **MAX SPEED RANGE - 2500 - 3000 RPM**
- **HARDENED BEARING STEEL**
- **NYLON RETAINER STANDARD**
- **GREASED, DOUBLE SEALED OR DOUBLE SHIELDED STANDARD**
- **AVAILABLE SINGLE SEALED OR SINGLE SHIELDED, OPEN, AND WITH OR WITHOUT GREASE**

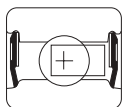
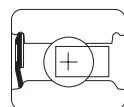
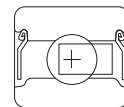
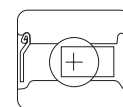
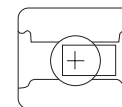

BEARING NUMBER					PRINCIPAL DIMENSIONS		
					BORE d (in) +.005/-.000	O.D. D (in) +.0000/-.0005	
DOUBLE SEAL	SINGLE SEAL	DOUBLE SHIELD	SINGLE SHIELD	OPEN			
4 3002DC	3002SC	3002DS	3002SS	3002NS	0.2500	0.6875	
3003DC	3003SC	3003DS	3003SS	3003NS	0.3125	0.8750	
3004DC	3004SC	3004DS	3004SS	3004NS	0.3750	0.8750	
3005DC	3005SC	3005DS	3005SS	3005NS	0.3125	0.9063	
3006DC	3006SC	3006DS	3006SS	3006NS	0.3750	0.9063	
3007DC	3007SC	3007DS	3007SS	3007NS	0.4375	0.9063	
3014DC	3014SC	3014DS	3014SS	3014NS	0.3750	1.1250	
3015DC	3015SC	3015DS	3015SS	3015NS	0.4375	1.1250	
3016DC	3016SC	3016DS	3016SS	3016NS	0.5000	1.1250	
3020DC	3020SC	3020DS	3020SS	3020NS	0.4375	1.3750	
3021DC	3021SC	3021DS	3021SS	3021NS	0.5000	1.3750	
3023DC	3023SC	3023DS	3023SS	3023NS	0.6250	1.3750	
3028DC	3028SC	3028DS	3028SS	3028NS	0.6250	1.6250	
3030DC	3030SC	3030DS	3030SS	3030NS	0.7500	1.6250	
5 3033DC	3033SC	3033DS	3033SS	3033NS	0.6250	1.7500	
5 3035DC	3035SC	3035DS	3035SS	3035NS	0.7500	1.7500	
5 3038DC	3038SC	3038DS	3038SS	3038NS	0.7500	2.0000	
5 3040DC	3040SC	3040DS	3040SS	3040NS	0.8750	2.0000	
5 3041DC	3041SC	3041DS	3041SS	3041NS	1.0000	2.0000	

- Width for sealed versions = 0.3125
- Width for sealed versions = 0.3438
- Weights given are for greased and sealed versions
- Multi-part seal
- O.D. Tolerance +.0000/-.0006

3000 Series Semi-Ground Radial Bearings

Semi-ground 3000 series bearings are specially designed to provide a line of economical bearings for lighter loads than the 1600 series and speeds to approximately 2500 rpm. The 3000 series bearings are dimensionally the same as the 1600 series bearings, except for the precision of the inner ring (as machined tolerances). Careful heat treatment provides a uniform and exact degree of hardness for maximum life.

The 3000 series bearings are precision ground to the same close tolerances on the O.D. as the 1600 series with exceptional care given to the ball grooves. A ball retainer, or separator, is employed to increase the range of allowable speeds by reducing ball contact friction. The 3000 series radial bearing is available open, single or double shielded, or single or double sealed. The double shielded and double sealed versions are grease packed as standard. Open and single closure bearings can be furnished with or without grease as desired.

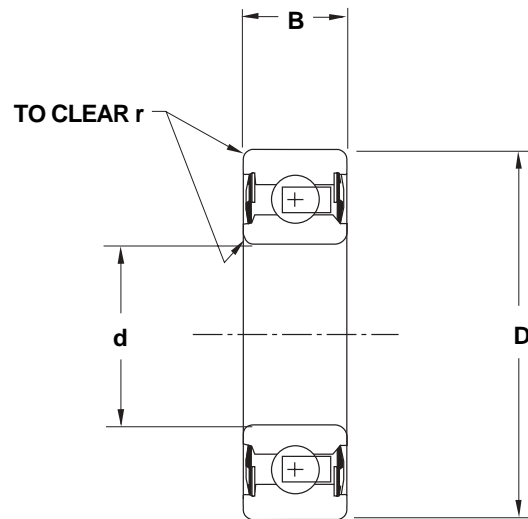

	BASIC LOAD RATINGS		WEIGHT	ABUTMENT AND FILLET DIMENSIONS			
	WIDTH B (in) +.0000/-0.005	DYNAMIC C (lb)		STATIC C ₀ (lb)	d _a min (in)	D _a max (in)	r max (in)
	0.2500 ①	255	170	0.02	0.614	0.330	0.012
	0.2813 ②	325	255	0.03	0.778	0.474	0.012
	0.2813 ②	325	255	0.03	0.778	0.474	0.015
	0.3125	350	300	0.04	0.778	0.503	0.012
	0.3125	350	300	0.04	0.778	0.517	0.015
	0.3125	350	300	0.03	0.778	0.517	0.015
	0.3750	600	475	0.06	1.014	0.595	0.025
	0.3750	600	475	0.06	1.014	0.622	0.025
	0.3750	600	475	0.06	1.014	0.622	0.025
	0.4375	940	850	0.12	1.203	0.658	0.025
	0.4375	940	850	0.11	1.203	0.720	0.025
	0.4375	940	850	0.10	1.203	0.753	0.025
	0.5000	1300	1010	0.18	1.446	0.845	0.025
	0.5000	1300	1010	0.16	1.446	0.965	0.025
	0.5000	1300	1025	0.22	1.530	0.845	0.025
	0.5000	1300	1025	0.22	1.530	0.965	0.025
	0.5625	1480	1350	0.32	1.760	0.988	0.035
	0.5625	1480	1350	0.29	1.760	1.113	0.035
	0.5625	1480	1350	0.26	1.760	1.197	0.035

6900 Series Semi-Ground Radial Bearings, Extended Inner with Flanged Housing

- EASY TO USE INCH DIMENSIONS
- MEDIUM LOADS
- MAX SPEED RANGE - 5000 - 6000 RPM
- THROUGH HARDENED
- RETAINER DESIGN
- NYLON RETAINER STANDARD
- DOUBLE SEALED STANDARD
- EXTENDED INNER RING WITH TWO SET SCREWS
- BEARINGS ARE AVAILABLE WITH OR WITHOUT FLANGE



ASSEMBLY NUMBER		PRINCIPAL DIMENSIONS							
		d (in) Bore +.005/-.000	D (in) O.D. +.0000/-.0005	B (in) +.000/-.005	C (in)	E (in)	F (in)	G (in) Bolt Centers	H (in)
FLANGED UNIT	BEARING ONLY								
6906	6906 - B	0.375	0.9063	0.3125	0.6875	0.555	0.375	1.875	2.500
6908	6908 - B	0.500	1.6250	0.5000	1.0000	0.995	0.500	2.875	3.750
6910	6910 - B	0.625	1.6250	0.5000	1.0000	0.995	0.500	2.875	3.750
6912 ①	6912 - B ①	0.750	2.0000	0.5625	1.0625	1.293	0.500	3.250	4.125
6916 ①	6916 - B ①	1.000	2.0000	0.5625	1.0625	1.293	0.500	3.250	4.125

① O.D.Tolerance for 6912 and larger is +.0000/-.0006

② Weights given are for flanged versions.

6900 Series Semi-Ground Radial Bearings, Extended Inner with Flanged Housing

The 6900 series consists of a double sealed, ground bearing with an extended inner ring. It is provided with two set screws and a flanged housing designed for flush mounting. Bearings are supplied assembled in the housing. Flanged and non-flanged units are available from stock.

The pressed steel flanged housing provides a secure yet inexpensive means for holding the bearing in place. Although these units are not of the self-aligning type, they will accommodate a limited amount of angular misalignment.

For less exacting applications involving light loads and speeds up to 2500 rpm, semi-ground type bearings may be specified in lieu of a precision ground bearing at a cost savings. These assemblies are generally produced to order and may or may not be in stock. Contact your Nice sales representative or customer service for more information.

FLANGED UNIT

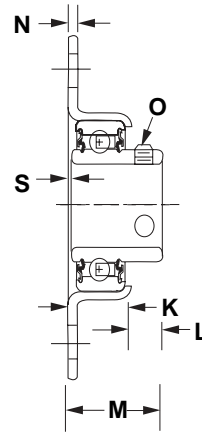

BEARING ONLY

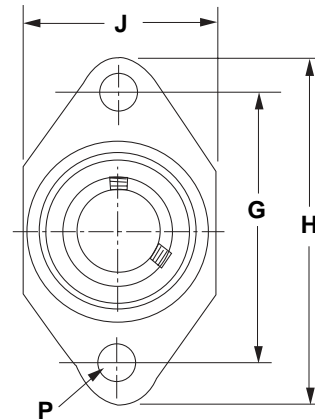
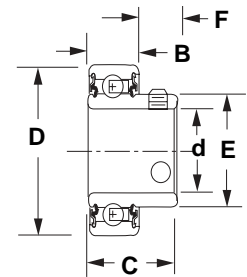

PRINCIPAL DIMENSIONS									BASIC LOAD RATINGS		WEIGHT
J (in) Overall Width	K (in)	L (in)	M (in)	N (in)	O 2-Set Screws	P (in) Hole Dia.	S (in)	DYNAMIC C (lb)	STATIC C ₀ (lb)	W ² (lb)	
1.125	0.3438	0.3438	0.6875	0.035	8-32	0.3125	0	580	300	0.07	
1.875	0.6875	0.4375	1.0000	0.062	1/4-28	0.4375	0.01	1610	1000	0.35	
1.875	0.6875	0.4375	1.0000	0.062	1/4-28	0.4375	0.01	1610	1000	0.32	
2.250	0.6875	0.4375	1.1250	0.062	1/4-28	0.4375	0.062	1870	1350	0.55	
2.250	0.6875	0.4375	1.1250	0.062	10-32	0.4375	0.062	1870	1350	0.33	

7500 Series Heavy Duty Precision Ground Radial Bearings

- **PRECISION GROUND ON ALL CONTACT SURFACES, SIMILAR TO THE 1600 SERIES**
- **EASY TO USE INCH DIMENSIONS**
- **MEDIUM LOADS**
- **MAX SPEED RANGE - 5000 - 6000 RPM**
- **THROUGH HARDENED BEARING STEEL**
- **RETAINER DESIGN**
- **NYLON RETAINER STANDARD**
- **DOUBLE SEALED STANDARD**
- **HIGHLY EFFECTIVE SINGLE LIP CONTACT SEAL WITH TRASH GUARD**
- **AVAILABLE SINGLE SEALED OR OPEN**
- **ALL BEARINGS HAVE A SNAP RING GROOVE (SNAP RING ASSEMBLED AS AN OPTION)**
- **RECOMMENDED FOR APPLICATIONS WHERE ACCURATE, QUIET PERFORMANCE AND SUPERIOR SEALING ARE REQUIRED**



BASIC BEARING NUMBER	PRINCIPAL DIMENSIONS					
	BORE d (in) +.0000/-.0005	O.D. D (in) +.0000/-.0005	OUTER WIDTH B (in) +.000/-.005	A (in)	INNER WIDTH C (in) +.000/-.005	F (in)
7508	0.500	1.7500	0.625	0.0625	0.750	1.009
7510	0.625	1.7500	0.625	0.0625	0.750	1.009
7512	0.750	1.7500	0.625	0.0625	0.750	1.009
7514 ^①	0.875	2.0000	0.625	0.0625	0.750	1.306
7516 ^①	1.000	2.0000	0.625	0.0625	0.750	1.306
7518 ^①	1.125	2.5625	0.750	0.0625	0.875	1.672
7520 ^①	1.250	2.5625	0.750	0.0625	0.875	1.672

① O.D.Tolerance for 7514 and larger is +.0000/-.0006

② Radius R indicates the maximum fillet radius in housing or shaft which bearing will clear

③ Weights given are for greased and sealed versions

7500 Series Heavy Duty Precision Ground Radial Bearings

The Nice 7500 series bearings are single row retainer type radial bearings, similar in construction to the 1600 series. They incorporate a highly effective single lip contact seal, with metal guard. The inner and outer rings are turned from chrome steel and after careful heat treatment the through hardened rings are accurately ground to close tolerances.

The 7500 series bearings are recommended for applications requiring the accuracy of rotation and quiet performance of close tolerance precision grade bearings, and where a superior seal is required to retain lubricant and keep the bearing free from dust and dirt.

Normally double sealed (type DL), the 7500 series bearings can be produced to order with seals on one side only (type SL) or without seals (type NL). Double sealed bearings are grease packed as standard; however, all types can be furnished with or without grease packing as desired. All types are provided with a snap ring groove, with the snap ring assembled on the bearing as an option.

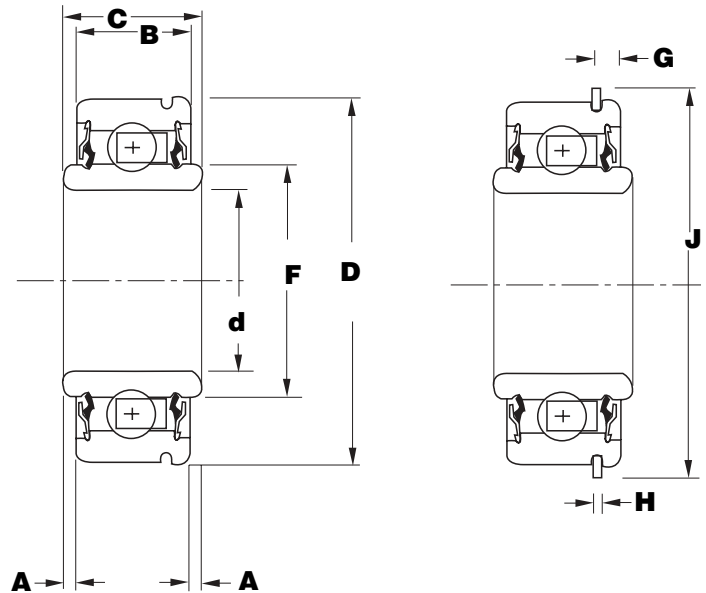

PRINCIPAL DIMENSIONS				WEIGHT W ³ (lb)	BASIC LOAD RATINGS		ABUTMENT AND FILLET DIMENSIONS		
G (in) +.000 -.005	H (in)	J (in)	R ² (in) Radius		DYNAMIC C (lb)	STATIC C₀ (lb)	d_a min (in)	D_a max (in)	r max (in)
0.136	0.042	1.9219	0.035	0.330	2595	1010	0.750	1.500	0.035
0.136	0.042	1.9219	0.035	0.290	2595	1010	0.875	1.500	0.035
0.136	0.042	1.9219	0.035	0.310	2595	1010	1.000	1.500	0.035
0.136	0.042	2.1563	0.035	0.360	2970	1350	1.125	1.750	0.035
0.136	0.042	2.1563	0.035	0.330	2970	1350	1.250	1.750	0.035
0.190	0.065	2.7656	0.035	0.795	5360	2620	1.375	2.312	0.035
0.190	0.065	2.7656	0.035	0.565	5360	2620	1.500	2.312	0.035

7600 Series Heavy Duty Precision Ground Radial Bearings with Extended Inner Ring

- **PRECISION GROUND ON ALL CONTACT SURFACES, SIMILAR TO THE 1600 SERIES**
- **EASY TO USE INCH DIMENSIONS**
- **MEDIUM LOADS**
- **MAX SPEED RANGE - 5000 - 6000 RPM**
- **THROUGH HARDENED**
- **CAGED DESIGN**
- **NYLON CAGE STANDARD**
- **DOUBLE SEALED STANDARD**
- **HIGHLY EFFICIENT SINGLE LIP CONTACT SEAL**
- **AVAILABLE SINGLE SEALED OR OPEN**
- **EXTENDED INNER RING WITH SET SCREWS**
- **ALL BEARINGS HAVE A SNAP RING GROOVE, SNAP RING ASSEMBLED AS AN OPTION**
- **RECOMMENDED FOR APPLICATIONS WHERE ACCURATE, QUIET PERFORMANCE AND SUPERIOR SEALING ARE REQUIRED**



BASIC BEARING NUMBER	PRINCIPAL DIMENSIONS					
	BORE d (in) +.0008/-0.0000	O.D. D (in) +.0000/-0.0005	OUTER WIDTH B (in) +.000/-0.005	A (in)	F (in)	G (in) +.005/-0.005
7608	.5000	1.7500	0.625	0.0625	1.009	0.136
7609	.5625	1.7500	0.625	0.0625	1.009	0.136
7610	.6250	1.7500	0.625	0.0625	1.009	0.136
7611	.6875	1.7500	0.625	0.0625	1.009	0.136
7612	.7500	1.7500	0.625	0.0625	1.009	0.136
7613 ①	.8125	2.0000	0.625	0.0625	1.306	0.136
7614 ①	.8750	2.0000	0.625	0.0625	1.306	0.136
7615 ①	.9375	2.0000	0.625	0.0625	1.306	0.136
7616 ①	1.0000	2.0000	0.625	0.0625	1.306	0.136
7617 ①	1.0625	2.5625	0.750	0.0625	1.672	0.190
7618 ①	1.1250	2.5625	0.750	0.0625	1.672	0.190
7620 ①	1.2500	2.5625	0.750	0.0625	1.672	0.190

① O.D. Tolerance for 7613 and larger is +.0000/-0.0006

② Radius R indicates the maximum fillet radius in housing or shaft which bearing will clear

③ Weights given are for greased and sealed versions

7600 Series Heavy Duty Precision Ground Radial Bearings with Extended Inner Ring

The Nice 7600 series bearings are single row retainer type radial bearings similar in construction to the 1600 series. They incorporate a highly efficient single lip contact seal with metal guard. The inner and outer rings are turned from chrome steel and after careful heat treatment the through hardened rings are accurately ground to close tolerances. The inner ring is extended and contains set screws whereas the 7500 series bearing does not.

The 7600 series bearings are recommended for applications requiring the accuracy of rotation and quiet performance of close limit precision grade bearings, and where a superior seal is required to retain lubricant and keep the bearing free from dust and dirt.

Normally double sealed (type DL), the 7600 series bearings can be produced to order with seals on one side only (type SL) or without seals (type NL). Double sealed bearings are grease packed as standard; however, all types can be furnished with or without grease packing as desired. All types are provided with a snap ring groove, with the snap ring assembled on the bearing as an option.

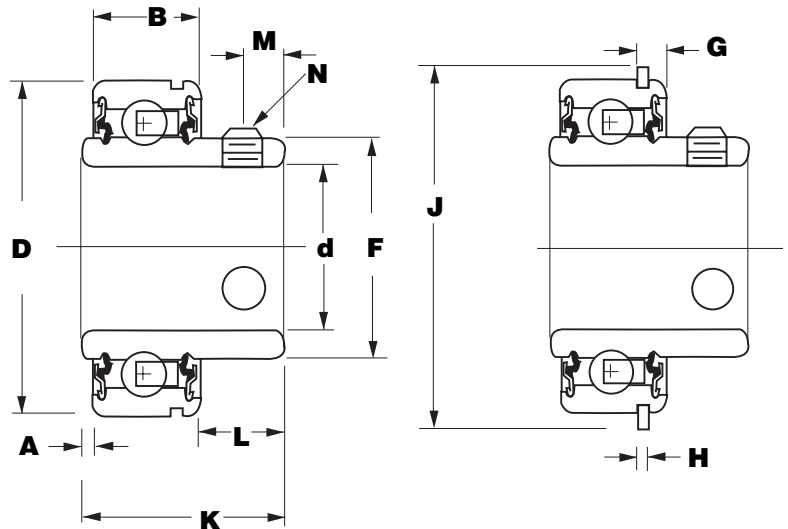

PRINCIPAL DIMENSIONS							BASIC LOAD RATINGS		WEIGHT
H (in)	J (in)	INNER WIDTH K (in) +.000/- .005	L (in)	M (in)	N 2 set screws	R ² (in) Radius	DYNAMIC C (lb)	STATIC C ₀ (lb)	W ³ (lb)
0.042	1.9219	1.092	0.405	0.233	10-32	0.035	2595	1010	0.36
0.042	1.9219	1.092	0.405	0.233	10-32	0.035	2595	1010	0.34
0.042	1.9219	1.092	0.405	0.233	10-32	0.035	2595	1010	0.32
0.042	1.9219	1.092	0.405	0.233	10-32	0.035	2595	1010	0.30
0.042	1.9219	1.092	0.405	0.233	10-32	0.035	2595	1010	0.28
0.042	2.1563	1.179	0.492	0.261	1/4-28	0.035	2970	1350	0.45
0.042	2.1563	1.179	0.492	0.261	1/4-28	0.035	2970	1350	0.43
0.042	2.1563	1.179	0.492	0.261	1/4-28	0.035	2970	1350	0.40
0.042	2.1563	1.179	0.492	0.261	10-32	0.035	2970	1350	0.36
0.065	2.7656	1.417	0.605	0.261	1/4-28	0.035	5360	2620	0.84
0.065	2.7656	1.417	0.605	0.261	1/4-28	0.035	5360	2620	0.80
0.065	2.7656	1.417	0.605	0.261	1/4-28	0.035	5360	2620	0.71

400 Series Single Row Unground Radial Bearings

- **RADIAL UNGROUND BEARING**
- **EASY TO USE INCH DIMENSIONS**
- **MODERATE LOADS**
- **MAX SPEED RANGE - 1000 - 1200 RPM**
- **HARDENED RINGS**
- **FULL COMPLEMENT OF BALLS**
- **FULLY UNITIZED ASSEMBLY**
- **BEARING SUPPLIED PRE-GREASED STANDARD**



BASIC BEARING NUMBER	BEARING DIMENSIONAL DATA					
	BORE d (in) +0.005/-0.000	O.D. D (in) +0.005/-0.000	WIDTH A (in) +0.010/-0.010	WIDTH B (in) Reference	BALLS	
					No.	Size
402-2V	0.250	0.687	0.250	0.250	10	1/8
400-4V	0.250	0.875	0.250	0.250	14	1/8
400-5V	0.312	0.875	0.250	0.250	14	1/8
400-6V	0.375	0.875	0.250	0.250	14	1/8
400-12V	0.375	0.937	0.312	0.312	15	1/8
400-14V	0.250	1.062	0.250	0.250	16	1/8
404-16V	0.375	1.062	0.250	0.250	16	1/8
400-18V	0.375	1.062	0.375	0.375	16	1/8
400-20V	0.375	1.125	0.375	0.375	18	1/8
400-21V	0.437	1.125	0.375	0.375	18	1/8
407-22V	0.500	1.125	0.370	0.406	15	5/32
400-23V	0.312	1.281	0.312	0.312	16	5/32
400-24V	0.375	1.281	0.312	0.312	16	5/32
400-26V	0.375	1.281	0.312	0.312	16	5/32
408-28V	0.500	1.375	0.470	0.500	16	3/16
410-30V	0.625	1.375	0.470	0.500	16	3/16
400-31V	0.500	1.500	0.437	0.500	17	3/16
400-33V	0.625	1.500	0.437	0.500	17	3/16
412-35V	0.750	1.625	0.375	0.500	18	3/16
400-36V	0.750	1.750	0.562	0.375	14	1/4
416-41V	1.000	2.000	0.572	0.625	17	1/4
400-47V	1.250	2.625	0.687	0.687	23	1/4
424-51V	1.500	2.750	0.750	0.750	20	5/16
400-55V	1.750	3.093	0.875	0.875	21	11/32
400-59V	2.000	3.375	0.937	0.937	21	0.375

NOTES

BALLS - Carbon Steel Grade 200

RINGS - Carbon Steel, Case Hardened

BANDS - 1010 Carbon Steel, Soft

Bearings supplied prelubricated with grease

400 Series Single Row Unground Radial Bearings

The Nice 400 series of unground radial ball bearings are designed for moderate loads and speeds where running accuracy and noise level requirements do not warrant the more expensive precision ground bearings. This series of bearings feature a full ball complement without a retainer and a soft steel band on the outer ring. This permits the bearing to be pressed into a housing without the necessity of close housing tolerances. The bearings are designed for use in applications with speeds not exceeding 1200 rpm.

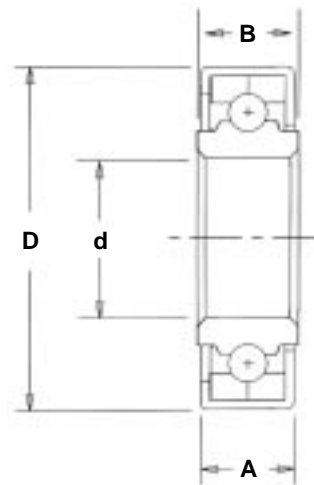

		RADIAL CAPACITY (LBS)					
WEIGHT W (lb)	REVOLUTIONS PER MINUTE						
	50	100	200	300	600	1200	
0.02	110	77	53	43	30	21	
0.03	156	108	75	60	42	30	
0.03	156	108	75	60	42	30	
0.03	156	108	75	60	42	30	
0.04	167	116	80	65	45	32	
0.05	178	124	85	69	48	34	
0.04	178	124	85	69	48	34	
0.07	178	124	85	69	48	34	
0.08	200	139	96	78	54	38	
0.07	200	139	96	78	54	38	
0.65	200	139	96	78	54	38	
0.09	275	193	133	107	75	52	
0.09	275	193	133	107	75	52	
0.09	275	193	133	107	75	52	
0.12	375	261	180	145	101	71	
0.10	375	261	180	145	101	71	
0.16	400	279	192	155	108	76	
0.14	400	279	192	155	108	76	
0.14	450	313	216	174	121	85	
0.22	625	430	300	240	168	117	
0.30	757	525	362	293	204	142	
0.75	1020	710	490	395	275	193	
0.80	1390	967	670	540	376	264	
1.10	1770	1225	847	683	477	332	
1.35	2100	1458	1010	817	567	396	

5000 Series Single Row Unground Flanged Radial Bearings

- **RADIAL UNGROUND BEARING**
- **EASY TO USE INCH DIMENSIONS**
- **MODERATE LOADS**
- **MAX SPEED RANGE - 1000 - 1200 RPM**
- **HARDENED RINGS**
- **FULL COMPLEMENT OF BALLS**
- **FULLY UNITIZED ASSEMBLY**
- **FLANGE ON O.D. LOCATES BEARING IN TUBE OR HOUSING**
- **BEARING SUPPLIED PRE-GREASED STANDARD**



BASIC BEARING NUMBER	BEARING DIMENSIONAL DATA						
	BORE A (in) +0.005/-0.000	O.D. B (in) +0.005/-0.000	OUTER WIDTH C (in) +0.010/-0.010	D (in)	E (in)	F (in)	INNER WIDTH G (in) ±.010
5561-V	0.250	0.687	0.250	0.047	0.750	0.050	0.250
5543-V	0.375	0.906	0.305	0.040	1.000	0.088	0.350
5507-V	0.312	1.125	0.385	0.062	1.250	0.125	0.437
5368-V	0.375	1.125	0.385	0.062	1.250	0.125	0.437
5491-V	0.500	1.125	0.385	0.062	1.250	0.125	0.437
5881-V	0.500	1.375	0.463	0.062	1.500	0.125	0.546
5273-V	0.625	1.375	0.463	0.062	1.500	0.125	0.546
5327-V	0.500	1.500	0.447	0.062	1.656	0.125	0.531
5281-V	0.500	1.578	0.515	0.140	1.687	0.234	0.609
5891-V	0.750	1.750	0.595	0.093	1.875	0.156	0.687
5875-V	0.750	2.000	0.572	0.093	2.125	0.218	0.718
5418-V	1.000	2.000	0.572	0.093	2.125	0.218	0.718

NOTES

BALLS - Carbon Steel Grade 200

RINGS - Carbon Steel, Case Hardened

BANDS - 1010 Carbon Steel, Soft

Bearings supplied prelubricated with grease

NICE

5000 Series Single Row Unground Flanged Radial Bearings

The 5000 series of bearings is similar in construction to the 400 series except it has a flange on the outer ring to locate the bearing when pressed into a tube or housing, thus eliminating the need for an external mounting device. The bearings are designed for moderate loads and speeds where running accuracy and noise level requirements do not warrant the more expensive precision ground bearings. This series of bearings feature a full ball complement without a retainer. The rings are case hardened and the soft steel band on the outer ring of the unitized assembly allows the bearing to be pressed into a housing without the necessity of close housing tolerances. The bearings are supplied pre-greased as a standard. The bearings are designed for use in applications with speeds not exceeding 1200 rpm.

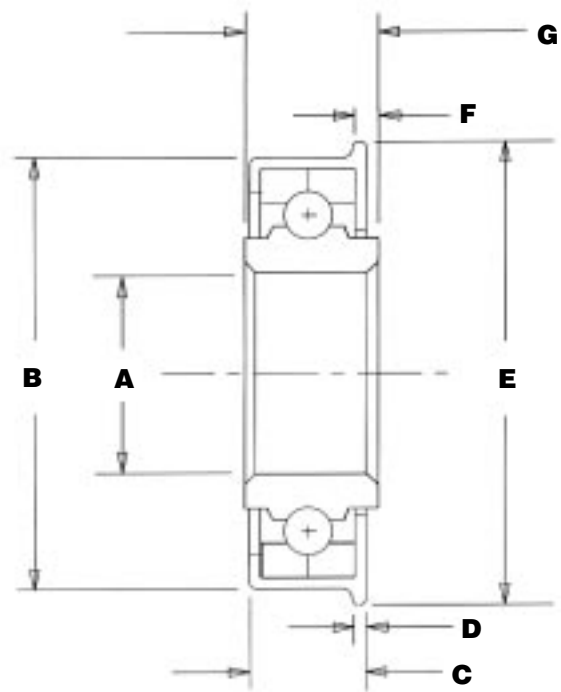

		WEIGHT W (lb)	RADIAL CAPACITY (LBS)						
BALLS			REVOLUTIONS PER MINUTE						
NO.	SIZE		50	100	200	300	600	1200	
10	1/8	0.02	110	77	53	43	30	21	
15	1/8	0.04	167	116	80	65	45	32	
15	5/32	0.08	200	139	96	78	54	38	
15	5/32	0.07	200	139	96	78	54	38	
15	5/32	0.07	200	139	96	78	54	38	
16	3/16	0.12	375	261	180	145	101	71	
16	3/16	0.10	375	261	180	145	101	71	
17	3/16	0.16	492	342	236	190	132	92	
12	1/4	0.23	535	367	258	206	144	100	
15	1/4	0.28	625	430	300	240	168	117	
17	1/4	0.32	757	525	362	293	204	142	
17	1/4	0.30	757	525	362	293	204	142	

500 Series Single Row Unground Combination Radial and Thrust Bearings

- **ANGULAR CONTACT UNGROUND BEARING**
- **EASY TO USE INCH DIMENSIONS**
- **MODERATE LOADS**
- **MAX SPEED RANGE - 1000 - 1200 RPM**
- **HARDENED RINGS**
- **FULL COMPLEMENT OF BALLS**
- **FULLY UNITIZED ASSEMBLY**



BASIC BEARING NUMBER	BEARING DIMENSIONAL DATA									COMBINED RADIAL			
	BORE A	O.D. B	WIDTH C ①	D	E	RADIUS R	BALLS		WEIGHT W	REVOLUTIONS PER MINUTE			
	(in)	(in)	(in)	(in)	(in)	(in)	No.	Size	(lb)	10		50	
	+0.005 /-0.000	+0.005 /-0.000	+0.010 /-0.010	+0.015 /-0.015						R	T	R	T
501	0.250	0.688	0.250	0.219	0.500	0.094	11	1/8	0.01	72	48	50	33
503	0.375	1.062	0.406	0.344	0.719	0.172	11	3/16	0.06	162	108	115	77
504	0.437	0.812	0.219	0.187	0.625	0.078	20	3/32	0.01	73	49	52	35
505	0.437	0.906	0.281	0.250	0.688	0.094	16	1/8	0.04	105	70	73	49
507	0.437	1.047	0.359	0.312	0.750	0.172	11	3/16	0.04	177	118	125	83
508	0.500	1.125	0.344	0.312	0.875	0.141	13	3/16	0.06	190	127	136	91
511	0.625	1.359	0.422	0.375	1.047	0.172	16	3/16	0.08	235	157	167	111
512	0.750	1.594	0.500	0.422	1.250	0.203	14	1/4	0.14	366	244	260	173
513	0.875	1.687	0.469	0.422	1.281	0.188	15	1/4	0.08	393	262	273	182
515 ②	1.000 T8	2.047	0.609	0.547	1.625	0.219	14	5/16	0.25	573	382	400	267
516 ②	1.125 T10	1.812	0.422	0.344	1.438	0.141	24	3/16	0.10	354	236	250	167
517 ②	1.250 T10	2.3075 T10	0.594	0.547	1.844	0.250	17	5/16	0.28	696	464	490	327
518 ②	1.312 T10	2.3075 T10	0.609	0.531	1.844	0.234	19	9/32	0.30	630	420	442	295

① Maximum fillet radius on shaft which the bearing will clear

② T8 = +.008/-0.000

T10 = +.010/-0.000

NOTES

BALLS - Carbon Steel Grade 200

RINGS - Carbon Steel, Case Hardened

BANDS - 1010 Carbon Steel, Soft

Bearings supplied prelubricated with grease

500 Series Single Row Unground Combination Radial and Thrust Bearings

The Nice 500 series of unground combination radial and thrust bearings are designed for applications where a pure radial bearing or a pure thrust bearing would be unsuitable. The Nice 500 Series is an angular contact bearing designed for applications where thrust and/or radial load carrying capability is required.

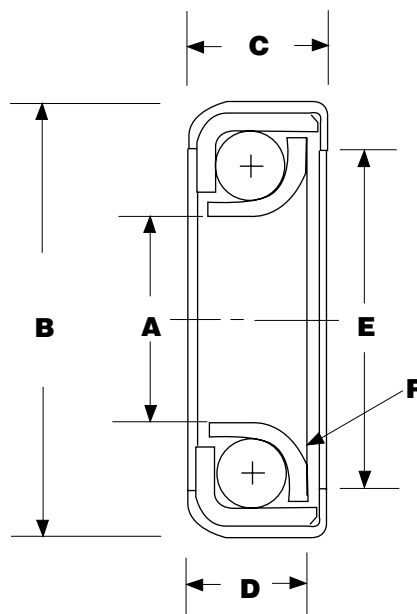

AND THRUST CAPACITY IN POUNDS									THRUST CAPACITY IN POUNDS					
REVOLUTIONS PER MINUTE									REVOLUTIONS PER MINUTE					
100		250		500		1000			10	50	100	250	500	1000
R	T	R	T	R	T	R	T							
35	23	23	15	16	11	10	7	71	58	43	25	18	15	
80	53	51	34	35	23	25	17	161	130	96	56	40	34	
25	17	23	15	16	11	10	7	73	59	44	25	18	15	
52	35	33	22	22	15	16	11	104	84	62	36	26	22	
88	59	56	37	40	27	27	18	176	142	105	61	44	37	
98	65	61	40	42	28	31	21	190	154	113	66	48	40	
117	78	74	50	52	35	37	25	234	189	140	81	59	49	
182	121	116	77	82	55	58	39	364	294	217	126	91	76	
196	131	124	83	85	57	60	40	390	315	233	135	98	81	
284	189	181	121	127	85	90	60	569	459	339	197	142	118	
177	118	112	74	79	53	57	38	351	284	209	122	88	73	
345	230	220	147	156	104	109	73	691	558	412	239	173	144	
312	208	199	133	139	93	99	66	625	505	373	217	156	130	

NICE

600 Series Unground Thrust Bearings

- **UNGROUND THRUST BEARING**
- **EASY TO USE INCH DIMENSIONS**
- **MODERATE LOADS**
- **MAX SPEED RANGE - 1000 - 1200 RPM**
- **HARDENED RINGS**
- **FULL COMPLEMENT OF BALLS**
- **SOFT STEEL BAND OFFERS EASE OF INSTALLATION**
- **UPPER RING IS FREE TO ROTATE AND HAS CLOSE FIT FOR SHAFTS**
- **LOWER RING IS FIXED AND HAS SHAFT CLEARANCE IN THE BORE**



BASIC BEARING NUMBER	BEARING DIMENSIONAL DATA						WEIGHT W (lbs)
	BORE A (in) +.000/-.010	BORE A1 (in) +/- .010	O.D. B (in) Max. ±.010	HEIGHT C (in) +/- .010	BALLS		
					No.	Size	
601-V	.250	.275	27/32	.333	10	5/32	0.03
602-V	.375	.400	1 3/64	.359	14	5/32	0.06
602 3/4-V	.453	.478	55/64	.281	15	1/8	0.03
603-V	.500	.525	1 17/64	.437	10	1/4	0.09
603 1/4-V	.500	.525	1	.344	12	3/16	0.04
605-V	.625	.656	1 1/8	.344	16	5/32	0.04
606-V	.625	.656	1 27/64	.453	12	1/4	0.12
607-V	.750	.775	1 21/32	.545	15	1/4	0.19
608-V	.875	.900	1 57/64	.594	17	1/4	0.28
609-V	1.000	1.075	2	.630	12	3/8	0.30
610-V	1.000	1.031	1 31/32	.625	18	1/4	0.29
610-1/4V	1.016	1.031	1 3/4	.625	16	1/4	0.21
611-V	1.063	1.094	1 31/32	.625	18	1/4	0.26
613-V	1.125	1.150	2 3/32	.625	19	1/4	0.31
616-V	1.250	1.275	2 11/32	.625	23	1/4	0.40
619-V	1.437	1.462	2 15/32	.625	23	1/4	0.43
621-V	1.500	1.525	2 19/32	.625	25	1/4	0.45

NOTES

BALLS - Carbon Steel Grade 200

RINGS - Carbon Steel, Case Hardened

BANDS - 1010 Carbon Steel, Soft

Bearings supplied prelubricated with grease

600 Series Unground Thrust Bearings

The Nice 600 series is designed for moderate speeds and medium thrust loads. These bearings utilize a full ball complement. Rings are cold forged from hardenable strip steel and are carefully heat treated. These bearings may be plated or manufactured from stainless steel upon request.

The entire assembly is housed in a soft steel band which lends itself to an easy press fit into a housing. The band also serves as a dust shield and helps retain the bearing lubricant. The upper ring is free to rotate in the band and has a close fit in the bore for the shaft. The lower ring is fixed in the band and has a shaft clearance in the bore.

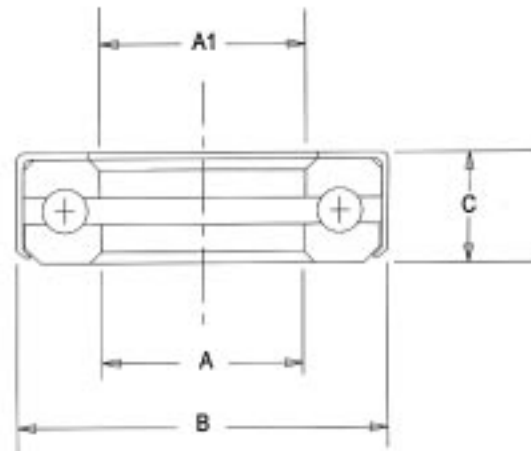

RADIAL CAPACITY (LBS)

REVOLUTIONS PER MINUTE

	REVOLUTIONS PER MINUTE					
	10 5	50	100	250	500	1000
	304	246	182	98	71	51
	426	344	254	138	100	71
	292	236	174	94	68	48
	780	630	465	252	182	129
	526	425	314	170	123	87
	858	693	511	277	200	143
	936	750	558	302	218	155
	1170	945	698	378	273	194
	1326	1071	791	428	309	220
	1706	1378	1017	551	398	284
	1404	1134	837	454	328	233
	1248	1008	744	403	291	207
	1404	1134	837	454	328	233
	1482	1197	883	479	346	246
	1794	1449	1069	579	419	298
	1794	1449	1069	579	419	298
	1950	1575	1162	630	455	324

BEARING Engineering Data

The methods, equations, and technical data presented in this section allow the user to select the correct bearings and estimate their performance for a wide range of applications. These calculations apply to Nice's selection of ground and semi-ground product lines, namely the 1600, 3000, 6900, 7500, and 7600 series. For applications with unusual operating conditions, Nice can provide engineering assistance and recommend the most suitable bearing design.

Where standard bearings cannot be used, Nice can meet the application requirements with a special bearing design specifically tailored for optimum performance. Contact your RBC Sales Engineer for special sizes, materials, application requirements, dimensions, and tolerances.

Capacity and Fatigue Life of Ball Bearings

The BASIC DYNAMIC LOAD RATING, C , or "dynamic capacity," for a ball bearing is that calculated, constant radial load at which a group of apparently identical bearings with a stationary outer ring can statistically endure one million revolutions of the inner ring.

The BASIC STATIC LOAD RATING, C_0 , or "static capacity," is that uniformly distributed load, which produces a maximum theoretical contact stress on the most heavily loaded ball of 609,000 psi. At this contact stress, a permanent deformation of ball and raceway occurs. This deformation is approximately 0.01% of the ball diameter in inches.

The RATING LIFE L_{10} , is a statistical measure of the life which 90% of a group of apparently identical ball bearings will achieve or exceed. For a single bearing L_{10} also refers to the life associated with 90% reliability. Median Life, L_{50} , is the life which 50% of the group of ball bearings will achieve or exceed. Median life is usually not greater than five times the rating life.

The relationship between rating life, load rating and load is:

$$L_{10} = (C/P)^3$$

with L_{10} = rating life (10^3 rev)
 C = basic load rating (lb)
 P = equivalent radial load (lb)

To obtain the rating life in hours, use:

$$L_{10 \text{ hrs}} = 16667/N * (C/P)^3$$

with N = speed (rpm)

The Equivalent Radial Load is defined as:

$$P = XF_r + YF_a$$

with F_r = radial load (lb)
 F_a = axial load (lb)
 X = see table below
 Y = see table below

For radial contact ball bearings calculate P with $X = 1.0$ and $Y = 1.0$. Then recalculate P with $X = 0.56$ and Y from the chart below. Use the larger value of P to determine L_{10} life.

$\frac{F_a}{nd^2}$	Y
25	2.30
50	1.99
100	1.71
150	1.55
200	1.45
300	1.31
500	1.15
750	1.04
1000	1.00

with n = number of balls
 d = diameter of balls

Operating Temperature

Maximum recommended operating temperatures for Nice ball bearings is a function of the bearing cage, seal, and grease materials used in the final assembly. For Nice's standard precision product series (600, 3000, 7500, 7600, and 6900) the maximum recommended operating temperature is 250°F. Operation at temperatures as high as 300°F can be tolerated intermittently. When operating at the extremes of allowable temperatures, grease may purge out between the seal lip and the bearing inner ring. If this is unacceptable for a particular application, other design arrangements might be necessary.

Nice's full complement unground series (400, 5000, 500, and 600) can operate at higher temperatures than above, and will be limited only by choice of lubricant. However, Nice Engineering should be consulted for application verification.

Limiting Speeds

Limiting operating speed is dependent upon the materials used in construction and the internal design and finishing of the bearing. For Nice's standard selection of ball bearings the recommended speed limits are as follows:

Bearing Series	Limiting Speed (rpm)
1600	5000
3000	2500
7500	5000
7600	5000
6900	5000
400	1200
5000	1200
500	1000
600	1000

Lubrication

All Nice double sealed and double shielded precision ground bearings (1600, 3000, 7500, 7600, and 6900 series) are supplied pre-greased 33% full with Shell Alvania #2 grease.

Shell Alvania #2 is a general purpose lithium soap grease with a useful temperature range of -40°F to +280°F. Single closure and open bearings are supplied slushed with a rust preservative. Nice can supply bearings with a wide variety of greases by special order, some of which are listed below. Contact Nice Engineering for details.

GREASES

Manufacturer	Product Trade Name	Temperature Range (°F)
Amoco	Amolith#2	-40 to +250
Chevron	Ultra Duty#1	-20 to +350
Chevron	SRI-2	-22 to +347
Dupont	Krytox 240 AC	-30 to +550
Exxon	Unirex #2	-40 to +400
Exxon	Andok C	+14 to +250
Mobil	Mobilgrease 28	-65 to +250
Shell	Alvania #2	-40 to +284
Shell	Alvania #3	-40 to +284
Shell	Dolium R	-40 to +320
Shell	Darina AX	-40 to +320

Retainers/Cages

Nice precision ground ball bearings of standard production are fitted with snap-in ball riding retaining cages made from heat stabilized polyamide 6/6. For special applications or design requirements cages made of special materials can be supplied. These include pressed steel or stainless steel, glass reinforced polyamide 6/6, and brass. Availability of bearings fitted with non-standard cages should be checked before ordering.

Axial Load Capacity

Deep groove ball bearings by nature of their design can carry axial loads either alone or in combination with radial loads. Axial load capacity of standard bearings is 0.5 times the Basic Static Load Rating, C_0 of that bearing. Smaller bearings should not be subject to a load greater than 0.25 times C_0 . Excessive axial loads can lead to serious reduction of bearing service life.

Misalignment

Radial deep groove ball bearings do have the ability to accommodate a limited amount of angular misalignment. The amount of angular misalignment that can be tolerated before adversely affecting bearing performance is a function of a variety of parameters. Internal radial clearance, internal design, applied loads, and the size of the bearing all play a role in determining the bearing's misalignment capability. Because of this, exact values for allowable misalignment are not provided. Under normal operating conditions, a safe estimate of permissible angular misalignment is usually between .0005 in/in and .003 in/in. Noise levels may increase when the bearing is operating misaligned.

Finish and Accuracy

Nice ball bearings are available in several different finish and accuracy grades that may be selected to suit the functionality of a particular application.

Nice fully ground precision bearings are available in single row radial configurations. Boundary dimensions and internal fit-up are held to exacting tolerances by precision grinding of all external surfaces and both ball grooves. These bearings are recommended for applications requiring quiet running, higher speeds, and applied loads. Normal tolerances for series 1600, 7500, and 7600 bearings range from 0.0005" to 0.001". See product tables for exact tolerances.

Nice functional precision and unground bearings are designed for those applications where speeds and loads are moderate, and running accuracy and noise requirements do not warrant a fully ground precision bearing. Single row radial, single row angular contact, and thrust ball bearings can be supplied in semi-ground or unground accuracy. Series 3000, 6900, 400, 5000, 500, and 600 bearings are available with functional tolerances that range from 0.005" to 0.010". See product tables for exact tolerances.

Seals and Shields

Contact seals are used on bearings to prevent solid contaminants and moisture from entering the bearing while retaining the lubricant in the bearing. Nice design and field experience has resulted in a variety of heavy duty and effective sealing designs.

The Nice RS1P seal, which is standard on the 1600, 3000, and 6900 series bearings, is made of oil and wear resistant synthetic rubber with a steel reinforcement. The sealing action is accomplished via interference (deflection) of the seal lip against a recess in the inner ring shoulder. The outside diameter of the seal is retained in a recess groove cut into the outer ring. The DC seal is an old style multi-part assembly consisting of a nylon seal insert held in place with a metal shield. It is a cost effective seal used only on a few sizes and specials. The Nice DL and Super Ag seals are special high efficiency contact seals for heavy duty applications. They are constructed of synthetic rubber molded to the back of a metal shroud or guard. The seal lip rides in a labyrinth groove for reduced seal drag and lower torque against the inner ring land surface.

Bearings fitted with non-contacting metal shields are primarily intended for applications where the inner ring rotates and low drag torque is a requirement. They retain the grease at normal operating speeds and temperatures while protecting the bearing from contamination. Metal shields are also utilized in applications where contaminants may pose a threat to the seal materials.

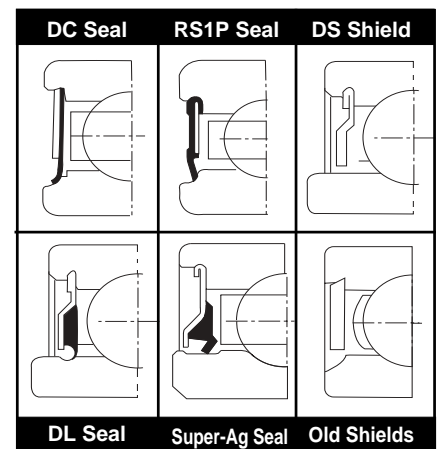

Radial Internal Clearance

All Nice single row deep groove ball bearings are designed and produced with radial internal clearance to provide for optimum performance. Nice ball bearings are supplied with "normal" radial clearance as standard, but can be ordered with radial clearance tighter than normal or looser than normal as a special item. The values listed in the table below apply to bearings before mounting and under no load and are supplied as a design guide. Consult Nice engineering when ordering other than normal radial clearance.

RADIAL INTERNAL CLEARANCE (.0001) INCH				
PRECISION LEVEL SERIES / TYPE	NORMAL MIN.-MAX.	TIGHT MIN.-MAX.	LOOSE MIN.-MAX.	EXTRA LOOSE MIN.-MAX.
1600/GROUND	2 - 12	2 - 6	7 - 22	10 - 25
3000/SEMI-GROUND	10 - 50	10 - 40	10 - 60	10 - 70
7500/GROUND	2 - 12	2 - 6	7 - 22	10 - 25
7600/GROUND	2 - 12	2 - 6	7 - 22	10 - 25
6900/SEMI-GROUND	10 - 30	10 - 20	10 - 40	10 - 25
400/UNGROUND	10 - 70	---	---	---
500/UNGROUND	10 - 70	---	---	---

Recommended Shaft and Housing Fits

Proper mounting fits of ball bearings to shafts and in housings are critical to their performance. Excessively tight or excessively loose fits can result in premature bearing failures. Recommended fit values have been established which will facilitate optimum bearing performance.

The shaft and housing fits listed below apply to the Nice 1600 and 7500 series bearings. They may also be used for the housing fits only on the 3000, 7600, and 6900 series bearings.

HOUSING FITS									
BEARING OUTSIDE DIAMETER		HOUSING ROTATING				HOUSING STATIONARY			
		Housing Inside Dia		Theoretical Fit		Housing Inside Dia		Theoretical Fit	
MAX	MIN	MAX	MIN	TIGHT	LOOSE	MAX	MIN	TIGHT	LOOSE
0.6250	0.6245	0.6252	0.6245	0.0005	0.0007	0.6255	0.6250	0.0000	0.0010
0.6875	0.6870	0.6887	0.6870	0.0005	0.0007	0.6880	0.6875	0.0000	0.0010
0.7500	0.7495	0.7502	0.7495	0.0005	0.0007	0.7505	0.7500	0.0000	0.0010
0.8750	0.8745	0.8752	0.8745	0.0005	0.0007	0.8755	0.8750	0.0000	0.0010
0.9063	0.9058	0.9065	0.9058	0.0005	0.0007	0.9068	0.9063	0.0000	0.0010
1.1250	1.1245	1.1252	1.1242	0.0008	0.0007	1.1255	1.1250	0.0000	0.0010
1.3750	1.3745	1.3752	1.3742	0.0008	0.0007	1.3755	1.3750	0.0000	0.0010
1.6250	1.6245	1.6252	1.6242	0.0008	0.0007	1.6258	2.0000	0.0000	0.0013
1.7500	1.7495	1.7502	1.7492	0.0008	0.0007	1.7508	2.2125	0.0000	0.0013
1.8750	1.8745	1.8752	1.8742	0.0008	0.0008	1.8758	1.8750	0.0000	0.0013
2.0000	1.9994	2.0002	1.9990	0.0010	0.0008	2.0010	2.0000	0.0000	0.0016
2.1250	2.1244	2.1252	2.1240	0.0010	0.0008	2.1260	2.1250	0.0000	0.0016
2.2500	2.2494	2.2502	2.2490	0.0010	0.0008	2.2510	2.2500	0.0000	0.0016
2.5000	2.4994	2.5002	2.4990	0.0010	0.0008	2.5010	2.5000	0.0000	0.0016
2.5625	2.5619	2.5627	2.5615	0.0010	0.0008	2.5635	2.5625	0.0000	0.0016

SHAFT FITS									
BEARING BORE DIAMETER		SHAFT ROTATING				SHAFT STATIONARY			
		Shaft Dia		Theoretical Fit		Shaft Dia		Theoretical Fit	
MAX	MIN	MAX	MIN	TIGHT	LOOSE	MAX	MIN	TIGHT	LOOSE
0.1875	0.1805	0.1870	0.1865	0.0005	0.0010	0.1870	0.1865	0.0005	0.0010
0.2500	0.2495	0.2500	0.2495	0.0005	0.0005	0.2495	0.2490	0.0000	0.0010
0.3125	0.3120	0.3125	0.3120	0.0005	0.0005	0.3120	0.3115	0.0000	0.0010
0.3750	0.3745	0.3750	0.3745	0.0005	0.0005	0.3745	0.3740	0.0000	0.0010
0.4375	0.4375	0.4375	0.4370	0.0005	0.0005	0.4370	0.4365	0.0000	0.0010
0.5000	0.4995	0.5000	0.4995	0.0005	0.0005	0.4995	0.4990	0.0000	0.0010
0.5625	0.5620	0.5625	0.5620	0.0005	0.0000	0.5620	0.5615	0.0000	0.0010
0.6250	0.6245	0.6250	0.6245	0.0005	0.0005	0.6245	0.6240	0.0000	0.0010
0.7500	0.7495	0.7500	0.7495	0.0005	0.0005	0.7495	0.7490	0.0000	0.0010
0.8750	0.8745	0.8752	0.8747	0.0007	0.0003	0.8745	0.8740	0.0000	0.0010
1.0000	0.9995	1.0002	0.9997	0.0007	0.0003	0.9995	0.9990	0.0000	0.0010
1.1250	1.1245	1.1252	1.1247	0.0007	0.0003	1.1245	1.1240	0.0000	0.0010
1.2500	1.2405	1.2502	1.2497	0.0007	0.0003	1.2495	1.2490	0.0000	0.0010
1.3125	1.3120	1.3127	1.3122	0.0007	0.0003	1.3120	1.3115	0.0000	0.0010
1.3750	1.3745	1.3752	1.3747	0.0007	0.0003	1.3740	1.3740	0.0000	0.0010

AGRICULTURE Applications

The Nice 7227-4V stud mounted cam follower bearing is utilized in hay tine rake applications. It employs specially designed heavy duty seals to withstand the harsh working environment. It features an internal hex socket for ease of installation.

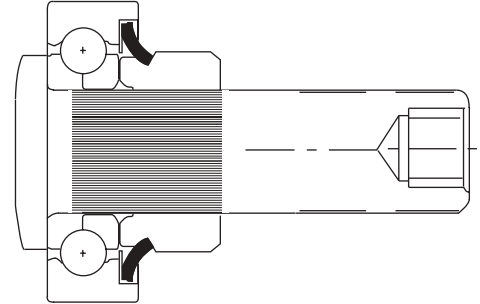

The Nice 8212-1TN radial ball bearing features special land riding seals and an extended inner ring. It is dimensionally unique and is used in hay baler rakes to support the tine bar shafts. It is designed to withstand the harsh environment and heavy loads that it encounters.

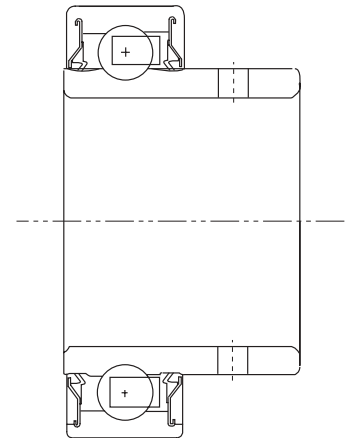

The 8403-1V is another radial ball bearing cam follower. It is used to guide hay rake tine bars on agricultural equipment. It features a spherical O.D. to accommodate any angular misalignment. It has two seals on one side and a fully enclosed dust shield on the other to keep dirt and hay debris out of the bearing.

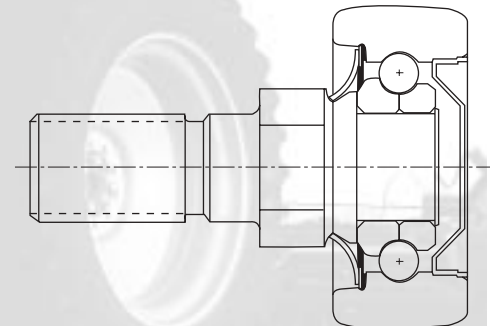

SPECIALS and Applications

PUMPS AND METERS

The 7473-J1 radial bearing features all stainless steel construction including the ball retainer. This precision ground bearing is used in a gas meter pump where it is immersed in gasoline. It therefore is not lubricated. This application requires a high degree of corrosion resistance, accuracy, and reliability.

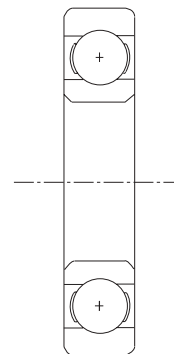

CANNING AND BOTTLING MACHINERY

The 8317-TN is a fully ground radial ball bearing featuring a molded urethane tire on the O.D. of the bearing. It is used in a bottle making machine to guide the bottles. The soft urethane tire minimizes handling damage due to contact with the bearing.

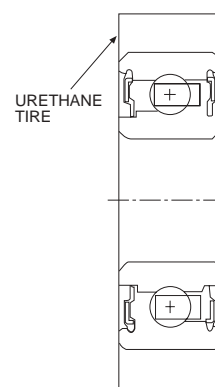

WOODWORKING MACHINERY

The Nice 8224-TN is a fully ground radial ball bearing featuring a track wheel configuration on the O.D. of the bearing. In addition, there is a four-point contact in the ball grooves to minimize the radial and axial play. This bearing is used to guide a radial arm saw along a linear track. Accuracy and repeatability are paramount in this application.

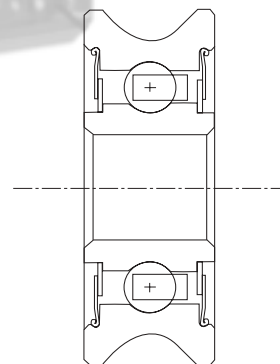

COMMERCIAL MOWERS

The Nice 7488-8 TNN RLD radial ball bearing is unique due to its ground inch dimension bore and the ground metric O.D. It is used in a variety of applications including lawn mower decks and conveyors. It features low torque seals for easier start up and a special radial play range for pre-loading. The seals also have an outboard dust shield for protection from debris.

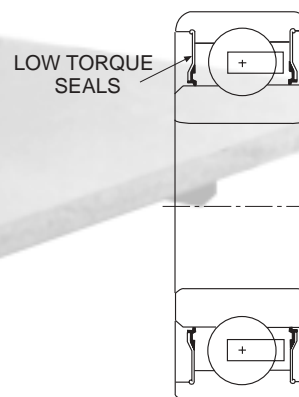

MATERIAL Handling

The CONV3Y4-TN is a fully ground conveyor bearing for higher load ratings and ease of installation. It is used in material handling applications. It features a milled slot on the O.D. for ease of installation as well as a heavy-duty seal for protection from coal dust, dirt, etc. The fully enclosed dust shield, in addition to the solid washer in the bore, effectively eliminates lubricant leakage thus allowing for a “sealed-for-life” bearing.

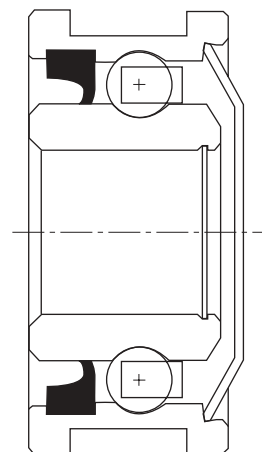

The CB504-TN heavy duty radial ball bearing is designed for long and dependable life in idler roller applications for bulk handling belt conveyors. The specially designed hexagonal bore accepts hexagonal shaped stub shafts in a ball and socket arrangement. This allows for a wide range of conveyor trough angles.

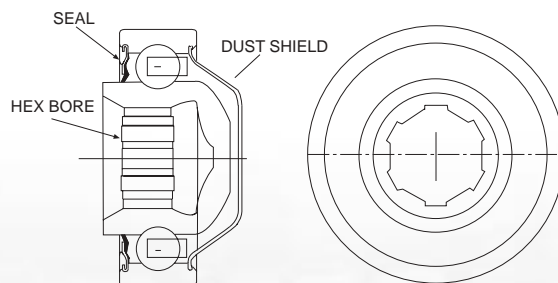

The Nice 7868-5TN radial ball bearing features special low torque land riding seals. The seals also have an outboard dust shield for protection from debris. One application for this design is an idler sprocket in chain drives. It has an inch dimension unground bore to facilitate mounting on standard fasteners. The bearing internal geometry and outer ring O.D. are ground to precision tolerances for smoother operation. It also features an extended inner ring on both sides to accommodate mounting clearances.

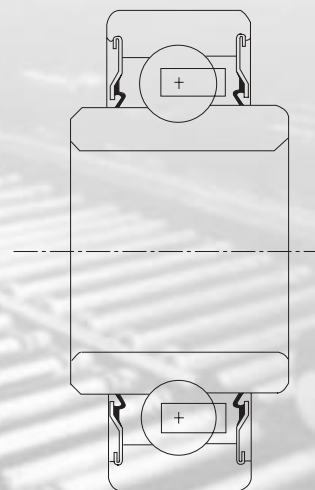

STEERING Column and Strut Bearings

The Nice NB543-1DCTN radial bearing is a fully ground double sealed thin section bearing. It is used in the headset of high-end bicycles. Because of shock loads, severe environmental conditions and the necessity of smooth feel for the rider, this bearing requires a high degree of accuracy and reliability. Unique metal backed nitrile seals are utilized to retain a special water-resistant grease for a greased for life bearing.

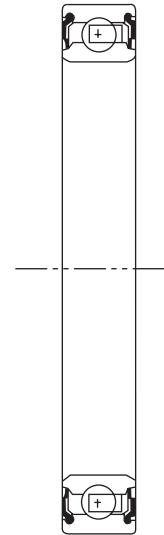

The 8493-V is a thrust ball bearing in which one of the rings is partially encapsulated in plastic. It is used in front strut mount applications of front wheel drive automobiles. It has the advantage of combining low mounting height, low weight, and reduced operational noise.

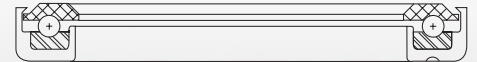

The Nice 8408-1V is a full complement, angular contact ball bearing used in steering column applications. It incorporates precise yet economical solid races, and features a ground O.D. for close-tolerance housing fits.



Nice Speciality Bearings



1510 Gehman Road
Kulpsville, PA 19443

SKF USA Inc.
1-888-753-3477

MRC Bearing Services
1-800-MRC-7000

SKF USA Inc. is the authorized distributor for Nice Ball Bearings, Inc.

® SKF is a registered trademark of SKF USA Inc.

Although care has been taken to assure the accuracy of the data compiled in this publication, SKF does not assume liability for errors or omissions.

© 2000 SKF USA Inc.

Publication 990-700 (10M/FG 6/2000)

version 6/2000

Printed in U.S.A.