

The PumPac 8000 Series is used in centrifugal pumps, large vertical electric motors, compressors, centrifuges, and other applications subject to thrust loads operating at relatively high speeds. The bearings are mounted so that the 40 degree bearing takes the primary thrust, or axial, load.

Traditionally, matched sets of 40 degree angular contact bearings are used to obtain maximum theoretical fatigue life, but in most instances only a fraction of the calculated life is actually achieved. At the heart of these premature failures are phenomena known as "ball sliding" and "ball shuttling" in the unloaded or inactive bearing. Angular contact bearings used in high speed (e.g. 3600 RPM) pumps and other applications require a minimum axial load for proper operation. Without axial load, gyroscopic forces in the unloaded bearing can cause the balls to rotate perpendicular to their true rolling axis and momentarily lose contact with the raceway. As a result, a microscopic wear or lapping process occurs giving the appearance of a burnished or polished raceway. The oil film thickness separating the ball and raceway is reduced producing friction and heat with lower oil viscosity, accelerating wear. This thermally unstable condition dramatically reduces bearing service life.

The main benefit of the PumPac is that the 15 degree bearing is designed with considerably less internal clearance than the 40 degree bearing making it less susceptible to the gyroscopic forces which result in ball sliding or shuttling. This bearing also provides additional radial stiffness helping to maintain integrity of the shaft and mechanical seals. The 40 degree, loaded bearing provides sufficient axial rigidity under the imposed thrust load.

The PumPac is furnished with a one piece, inner ring land guided, machined bronze cage and is manufactured to meet ABEC-3 grade tolerances. Dimensional stability is assured by heat treating for operation up to 375°F (190°C).

For identification purposes the 40 degree bearing is marked with the letter "A" and the 15 degree bearing with the letter "B". A "V" is etched on the outer ring surface of the set so that the apex falls on the "B" bearing. The set should be mounted so that the "V" points in the same direction as the primary shaft thrust load which places this load on bearing "A". Any reversing load is carried on bearing "B".

The PumPac is also available in the 8000BB PumPac Diamond series, which consists of a matched set of 15 degree (B) bearings in a back-to-back arrangement. The marking on the outer ring surface forms a diamond. This series is desirable in high speed, lightly loaded applications in which axial loads are balanced, resulting in reduced operating temperatures and increased life.

For applications involving very heavy primary thrust loads the PumPac may be furnished as a triplex set identified as the 8000AAB Series. It consists of two 40 degree bearings in tandem matched back-to-back (DB) with one 15 degree bearing. The outer ring surface of the set is marked with a "V" pointing in the direction of primary thrust.

For applications having a rotating shaft and stationary housing, an ISO k5 shaft fit and an ISO H6 housing fit is recommended as shown in the table on page 180.

**NOTE:** The basic radial load rating, C, is calculated according to the actual bearing geometry and not according to ISO/ABMA Standards.

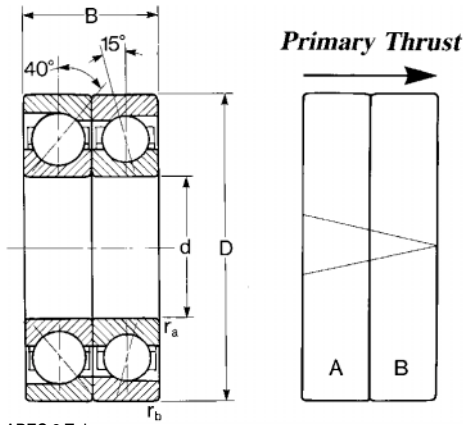

The PumPac 8000 Series consists of one 40° (A) and one 15° (B) bearings.

ABEC 3 Tolerances

MRC Bearing Number	Bore		Outside Diameter		Width		Fillet Radius <sup>1)</sup>				Basic Radial Load Rating <sup>2)</sup>								Speed Rating <sup>3)</sup>	
	d	in	D	in	B	in	r <sub>a</sub>		r <sub>b</sub>		40° (A)		15° (B)		Grease	Oil				
							mm	in	mm	in	Dynamic C <sup>4)</sup>	Static C <sub>0</sub>	Dynamic C <sup>4)</sup>	Static C <sub>0</sub>						
8218	90	3.5433	160	6.2992	60	2.3622	2.0	.08	1.0	.04	133 000	29 900	143 000	32 100	124 000	27 900	108 000	24 300	3 400	4 500
8219	95	3.7402	170	6.6929	64	2.5197	2.0	.08	1.0	.04	151 000	33 900	163 000	36 600	133 000	29 900	118 000	26 500	3 200	4 300
8220	100	3.9370	180	7.0866	68	2.6772	2.0	.08	1.0	.04	159 000	35 700	173 000	38 900	146 000	32 800	134 000	30 100	3 000	4 000
8222	110	4.3307	200	7.8770	76	2.9921	2.0	.08	1.0	.04	190 000	42 700	220 000	49 500	182 000	40 900	170 000	38 200	2 600	3 600
8224	120	4.7244	215	8.4646	80	3.1496	2.0	.08	1.0	.04	238 000	53 500	245 000	55 100	199 000	44 700	193 000	29 200	2 200	3 200
8238	190	7.4803	340	13.3858	110	4.3307	3.0	.12	1.0	.04	351 000	78 900	570 000	128 000	377 000	84 800	500 000	112 000	1 400	1 900
8308	40	1.5748	90	3.5433	46	1.8110	1.5	.06	1.0	.04	60 500	13 600	45 500	10 200	48 800	11 000	33 500	7 530	6 700	9 000
8309	45	1.7717	100	3.9370	50	1.9685	1.5	.06	1.0	.04	76 100	17 100	61 000	13 700	58 500	13 200	40 500	9 100	6 000	8 000
8310	50	1.9685	110	4.3307	54	2.1260	2.0	.08	1.0	.04	87 100	19 600	72 000	16 200	76 100	17 100	52 000	11 700	5 300	7 000
8311	55	2.1654	120	4.7244	58	2.2845	2.0	.08	1.0	.04	101 000	22 700	85 000	19 100	88 400	19 900	61 000	13 700	4 800	6 300
8312	60	2.3622	130	5.1181	62	2.4409	2.0	.08	1.0	.04	114 000	25 600	96 500	21 700	101 000	22 700	71 000	16 000	4 500	6 000
8313	65	2.5591	140	5.5118	66	2.5984	2.0	.08	1.0	.04	127 000	28 500	112 000	25 200	108 000	24 300	80 000	18 000	4 300	5 600
8314	70	2.7559	150	5.9055	70	2.7559	2.0	.08	1.0	.04	148 000	33 300	134 000	31 500	121 000	27 200	93 000	20 900	3 800	5 000
8315	75	2.9528	160	6.2992	74	2.9134	2.0	.08	1.0	.04	159 000	35 700	150 000	33 700	146 000	32 800	114 000	25 600	3 600	4 800
8316	80	3.1496	170	6.6929	78	3.0709	2.0	.08	1.0	.04	172 000	38 700	166 000	37 300	159 000	35 700	129 000	42 700	3 400	4 500
8317	85	3.3465	180	7.0866	82	3.2283	2.5	.10	1.0	.04	186 000	41 800	186 000	41 800	174 000	39 100	146 000	32 800	3 200	4 300
8318	90	3.5433	190	7.4803	86	3.3858	2.5	.10	1.0	.04	199 000	44 700	204 000	45 900	186 000	41 800	160 000	36 000	3 000	4 000
8319	95	3.7402	200	7.8740	90	3.5433	2.5	.10	1.0	.04	212 000	47 600	228 000	51 300	199 000	44 700	180 000	40 500	2 800	3 800
8320	100	3.9370	215	8.4646	94	3.7008	2.5	.10	1.0	.04	238 000	53 500	270 000	60 700	212 000	47 700	200 000	45 000	2 600	3 600
8322	110	4.3307	240	9.4488	100	3.9370	2.5	.10	1.0	.04	265 000	59 600	320 000	71 900	255 000	57 300	255 000	57 300	2 200	3 200
8326	130	5.1181	280	11.0236	116	4.5669	3.0	.12	1.0	.04	345 000	77 500	455 000	102 000	296 000	66 500	345 000	77 600	1 800	2 600
8330	150	5.9055	320	12.5984	130	5.1181	3.0	.12	1.0	.04	410 000	92 100	585 000	132 000	390 000	87 700	475 000	107 000	1 600	2 200
8336	180	7.0866	380	14.9606	150	5.9055	3.0	.12	1.0	.04	507 000	114 000	815 000	183 000	475 000	107 000	640 000	144 000	1 300	1 600

<sup>1)</sup> Fillet radius indicates maximum fillet radius on shaft or in housing which bearing corner will clear.

<sup>2)</sup> For thrust rating of bearing (A), multiply C by 1.75 and C<sub>0</sub> by 3.85.

For thrust rating of bearing (B), multiply C by 0.83 and C<sub>0</sub> by 2.00.

<sup>3)</sup> Values have been determined through historical application and practice. For a more complete explanation, see page 276.

<sup>4)</sup> Rating for one million revolutions or 500 hours at 33 1/3 RPM.

PumPac bearings require proper mounting orientation in respect to the direction of the imposed primary thrust load which must be taken on the "A" (40°) bearing. They should be installed so the "V" etched on the O.D. of the bearings points in the direction of the primary shaft thrust load, as illustrated below for PumPac 8000 and 8000 AAB arrangements.

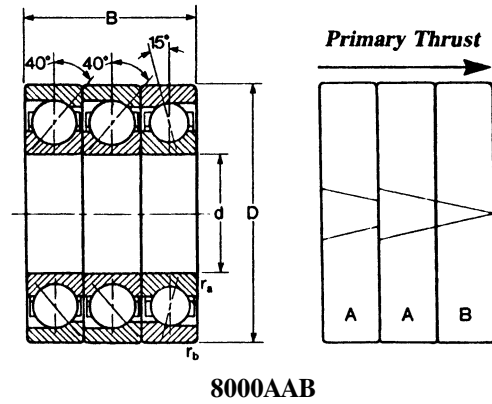
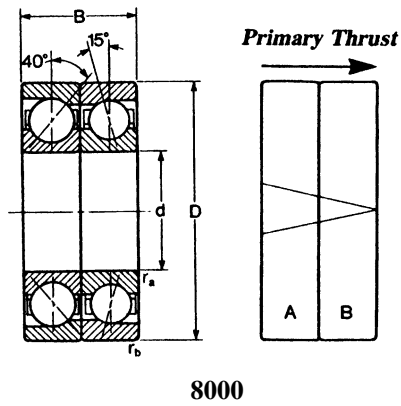

# PumPac Dynamic and Static Equivalent Radial Load and Life Rating

## MRC Bearing Services

The following method considers only thrust load in either direction with negligible radial load. For combined radial and thrust loads consult MRC Technical Services for analysis.

### Dynamic equivalent radial load

Primary thrust on bearing A (40°)

$$P = 0.57 F_A$$

Reversing thrust on bearing B (15°)

$$P = YF_A$$

P = Dynamic equivalent radial load

F<sub>A</sub> = Thrust load

Y = Thrust load factor

Z = Number of balls

D = Ball diameter

### Life rating

$$L_{10} = \left(\frac{C}{P}\right)^3 \text{ (millions of revolutions)}$$

or

$$L_{10h} = \frac{10^6}{60n} \left(\frac{C}{P}\right)^3 \text{ (Hours)}$$

C = Basic dynamic load rating

P = Dynamic equivalent radial load

n = speed in RPM

### Static equivalent radial load

Bearing A (40°)

$$P_0 = 0.26 F_A$$

Bearing B (15°)

$$P_0 = 0.5 F_A$$

P<sub>0</sub> = Static equivalent radial load

F<sub>A</sub> = Thrust load

$\frac{F_A}{ZD^2}$		Y
N/mm	Lb/in.	
0.172	25	1.47
0.345	50	1.40
0.689	100	1.30
1.03	150	1.23
1.38	200	1.19
2.07	300	1.12
3.45	500	1.02
5.17	750	1.00
6.89	1 000	1.00

Size	ZD <sup>2</sup>		Size	ZD <sup>2</sup>		Size	ZD <sup>2</sup>	
	mm	inch		mm	inch		mm	inch
8218B	7410	11.5	8310B	3990	6.19	8318B	11800	18.3
8219B	7900	12.3	8311B	4690	7.26	8319B	13100	20.3
8220B	9070	14.1	8312B	5430	8.42	8320B	14400	22.4
8222B	11700	18.1	8313B	5930	9.19	8322B	18900	29.3
8224B	13100	20.3	8314B	6800	10.5	8326B	25700	39.8
8238B	31200	48.4	8315B	8390	13.0	8330B	31500	48.8
8308B	2450	3.80	8316B	9470	14.7	8336B	45700	70.9
8309B	3020	4.69	8317B	10600	16.5			

Values of Y for loads not shown are obtained from chart at right.

Notes: For 8000BB series see page 80.  
For combined radial and thrust loads please contact MRC bearing services.

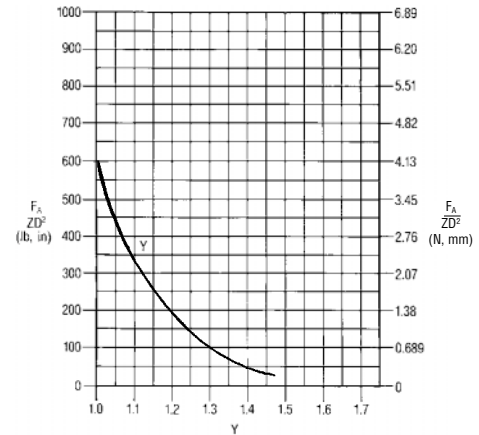

## Dynamic equivalent radial load and life calculation examples

### PumPac 8000 Series

Bearing size: 8310

Speed: 3500 RPM

Basic dynamic radial load rating (C):

Bearing A = 19600 lbf

Bearing B = 17100 lbf

#### Bearing A

Primary thrust load ( $F_A$ ) = 3000

Equivalent load ( $P$ ) =  $0.57 F_A$

$P = 0.57 \times 3000 = 1710$

$$\text{Life (L10)} = \left(\frac{C}{P}\right)^3 = \left(\frac{19600}{1710}\right)^3 = 1506 \times 10^6 \text{ Rev.}$$

or

$$\begin{aligned} \text{Life (L10h)} &= \frac{10^6}{60n} \left(\frac{C}{P}\right)^3 = \frac{10^6}{60 \times 3500} \left(\frac{19600}{1710}\right)^3 \\ &= 7170 \text{ Hrs} \end{aligned}$$

#### Bearing B

Reversing thrust load ( $F_A$ ) = 1000

$F_A/ZD^2 = 1000/6.19 = 162$

Equivalent load ( $P$ ) =  $Y F_A$

$Y = 1.22$

$P = 1.22 \times 1000 = 1220$

$$\text{Life (L10)} = \left(\frac{C}{P}\right)^3 = \left(\frac{17100}{1220}\right)^3 = 2753 \times 10^6 \text{ Rev.}$$

or

$$\begin{aligned} \text{Life (L10h)} &= \frac{10^6}{60n} \left(\frac{C}{P}\right)^3 = \frac{10^6}{60 \times 3500} \left(\frac{17100}{1220}\right)^3 \\ &= 13113 \text{ Hrs} \end{aligned}$$

### PumPac 8000 AAB Series

Bearing size: 8314 AAB

Speed: 3500 RPM

Basic dynamic radial load rating (C):

Bearings AA = 54400 lbf

Bearing B = 27200 lbf

#### Bearings AA

Primary thrust load ( $F_A$ ) = 5000

Equivalent load ( $P$ ) =  $0.57 F_A$

$P = 0.57 \times 5000 = 2850$

$$\text{Life (L10)} = \left(\frac{C}{P}\right)^3 = \left(\frac{54400}{2850}\right)^3 = 6954 \times 10^6 \text{ Rev.}$$

or

$$\begin{aligned} \text{Life (L10h)} &= \frac{10^6}{60n} \left(\frac{C}{P}\right)^3 = \frac{10^6}{60 \times 3500} \left(\frac{54400}{2850}\right)^3 \\ &= 33116 \text{ Hrs} \end{aligned}$$

### PumPac Diamond 8000 BB Series

Bearing size: 8317BB

Speed: 3000 RPM

Basic dynamic radial load rating (C):

$$\text{(Single Bearing)} = \frac{C}{(2)^{0.7}} = \frac{63200}{1.625} = 38890 \text{ lbf}$$

#### Primary Thrust Bearing

Primary thrust load ( $F_A$ ) = 2500

$F_A/ZD^2 = 2500/16.5 = 152$

Equivalent load ( $P$ ) =  $Y F_A$

$Y = 1.23$

$P = 1.23 \times 2500 = 3075$

$$\text{Life (L10)} = \left(\frac{C}{P}\right)^3 = \left(\frac{38890}{3075}\right)^3 = 2023 \times 10^6 \text{ Rev.}$$

or

$$\begin{aligned} \text{Life (L10h)} &= \frac{10^6}{60n} \left(\frac{C}{P}\right)^3 = \frac{10^6}{60 \times 3000} \left(\frac{38890}{3075}\right)^3 \\ &= 11238 \text{ Hrs} \end{aligned}$$

#### Reversing Thrust Bearing

Reversing thrust load ( $F_A$ ) = 1000

$F_A/ZD^2 = 1000/16.5 = 61$

Equivalent load ( $P$ ) =  $Y F_A$

$Y = 1.38$

$P = 1.238 \times 1000 = 1380$

$$\begin{aligned} \text{Life (L10)} &= \left(\frac{C}{P}\right)^3 = \left(\frac{38890}{1380}\right)^3 \\ &= 22381 \times 10^6 \text{ Rev.} \end{aligned}$$

or

$$\begin{aligned} \text{Life (L10h)} &= \frac{10^6}{60n} \left(\frac{C}{P}\right)^3 = \frac{10^6}{60 \times 3000} \left(\frac{38890}{1380}\right)^3 \\ &= 124,340 \text{ Hrs} \end{aligned}$$

#### Bearing B

Reversing thrust load ( $F_A$ ) = 1500

$F_A/ZD^2 = 1500/10.5 = 143$

Equivalent load ( $P$ ) =  $Y F_A$

$Y = 1.24$

$P = 1.24 \times 1500 = 1860$

$$\text{Life (L10)} = \left(\frac{C}{P}\right)^3 = \left(\frac{27200}{1860}\right)^3 = 3127 \times 10^6 \text{ Rev.}$$

or

$$\begin{aligned} \text{Life (L10h)} &= \frac{10^6}{60n} \left(\frac{C}{P}\right)^3 = \frac{10^6}{60 \times 3500} \left(\frac{27200}{1860}\right)^3 \\ &= 14900 \text{ Hrs} \end{aligned}$$