

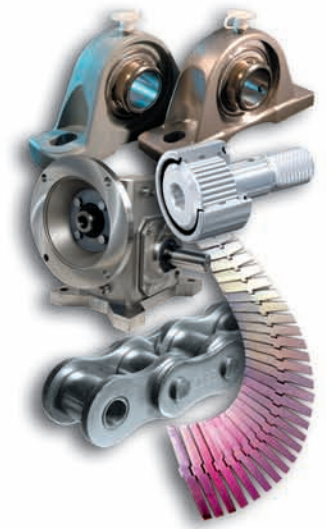

Browning
Morse
McGILL
SEALMASTER

**Corrosion
Resistant
Products**



EMERSON. CONSIDER IT SOLVED.™

Tough Environments, Durable Solutions

In an environment of increased operational requirements and tough regulatory guidelines, today's bearings and power transmission products are exposed to a host of demanding conditions. Such conditions may include corrosive cleaning agents, high pressure washdown and a wide array of environmental factors that can negatively impact performance. Overall, a balance of material strength and corrosion resistance, sealing and lubrication.

CRES — Corrosion Resistant Engineered Solutions

Introducing CRES from Emerson Power Transmission – a comprehensive line of corrosion resistant power transmission products. CRES products are engineered to perform in corrosive and contaminated environments.

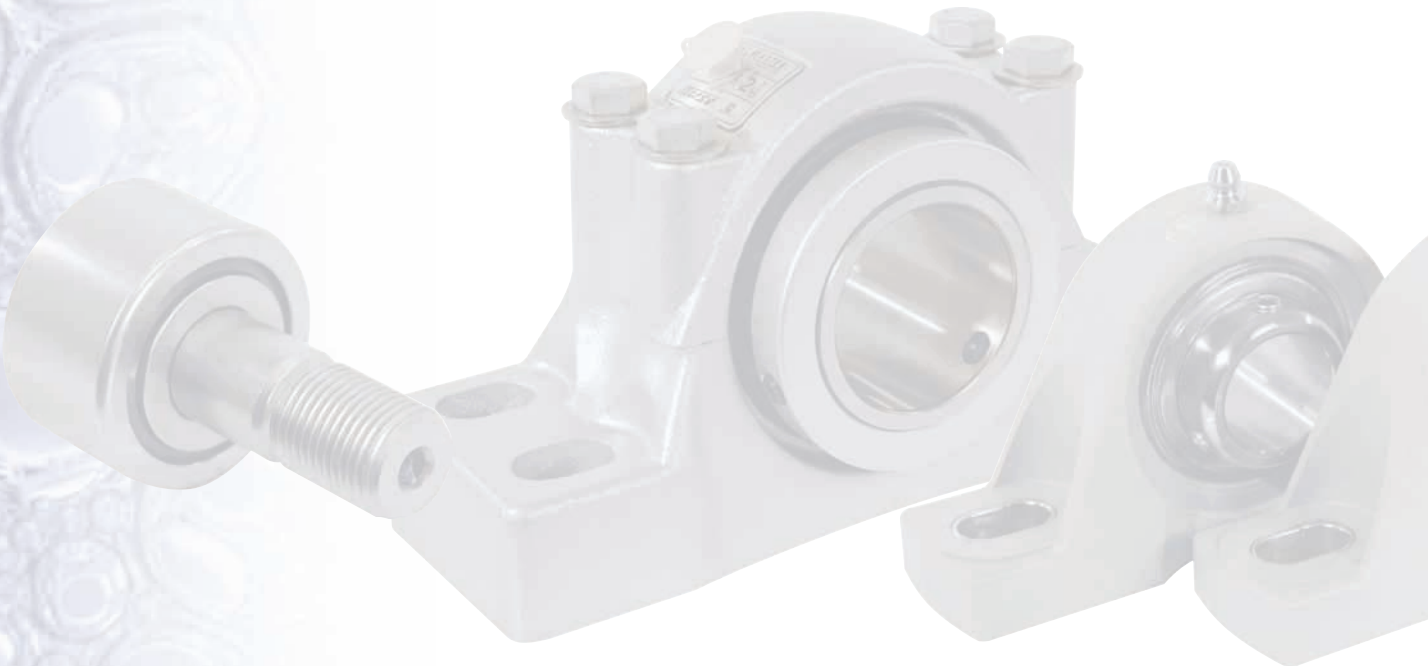

Topveyor® is a registered trademark of Emerson Power Transmission Manufacturing, L.P.

*The trade names, trademarks and/or registered trademarks of others used herein for comparison purposes, are NOT owned or controlled by Emerson Power Transmission Corporation and are believed to be owned by the following companies: Matveyor: Regina-Emerson, Ultop: UCC Corp.

The Emerson logo is a trademark and a service mark of Emerson Electric Co.

© Emerson Power Transmission Manufacturing, L. P. or affiliates 2007. All rights reserved.

CRES PRODUCTS



Bearing Products

Technical Overview and Selection	8-13
McGill® CRES Cam Followers	14-19
Sealmaster® CRES Mounted Roller Bearings	20-29
Browning® and Sealmaster CRES Mounted Ball Bearings	30-99

Gearing Products

Morse® Stainless Steel Raider® Plus Worm Gear Reducers	100-119
Expanded, Corrosion-Resistant Coatings For Browning Helical Reducers and Gearmotors Corro-Duty Gray and Corro-Duty White	120-121

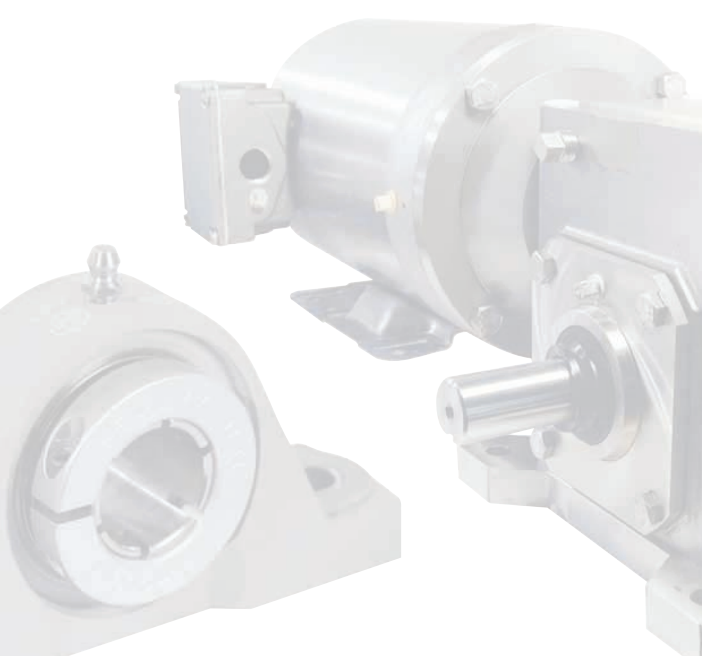

Component Products

CRES Components	122-130
Morse CRES Roller Chain	124-125
Morse CRES Conveying Components	126-127
Morse Gripper Chain	128-129
Browning Torque Overload Device	130
Morse Clutch	130

EMERSON POWER TRANSMISSION

Corrosion Resistant Engineered Solutions



Tough Environments, Durable Solutions

Focus Industries

- Meat and Poultry
- Bakeries and Snack Foods
- Bottling and Canning
- Pharmaceuticals
- Car Washes
- Pulp and Paper
- Marine



Bottling and Canning

In an efficient, high speed filling process, product failure can cost thousands of dollars in downtime. Emerson Power Transmission offers solutions that perform in wet environments. This high performance platform, combined with specialized sealing, greases and anti-corrosion materials and coatings, reduces downtime in today's competitive environment.

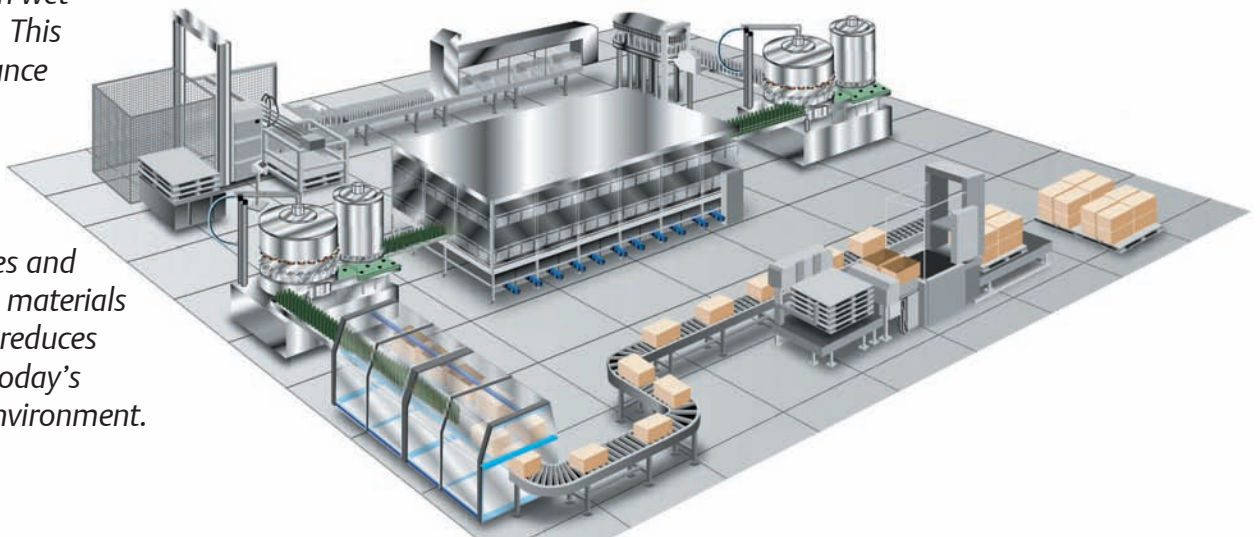

Applications

Bakeries and Snack Foods

Heat, flour and food particles make for a tough manufacturing environment. Emerson Power Transmission offers products with specialized tolerances to accommodate for the expansion and contraction of materials common to high temperature food processing.

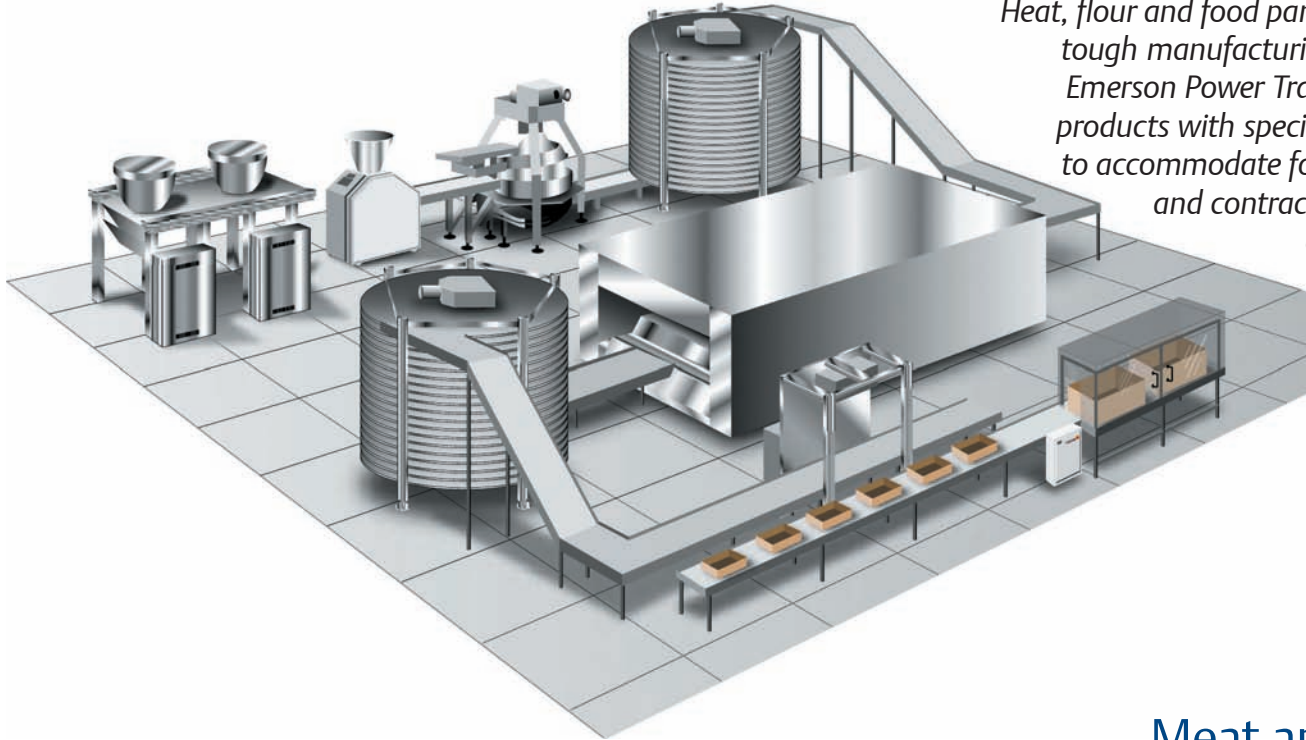

Meat and Poultry

Even the smallest amount of corrosion can shut down production so Emerson Power Transmission has created specific solutions that are HACCP-friendly.

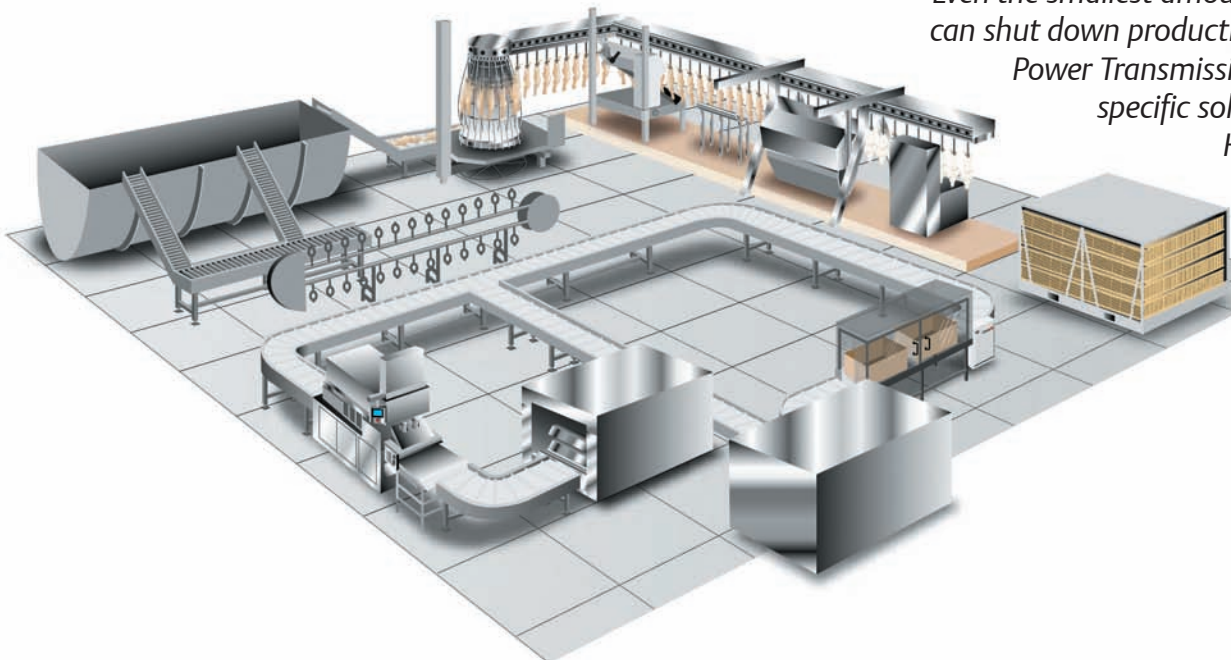

EMERSON POWER TRANSMISSION

Corrosion Resistant Engineered Solutions



CRES Bearings

The Emerson Power Transmission CRES bearing offering addresses various industries and applications by providing multiple solutions utilizing a variety of materials and sealing elements. CRES bearings assist customers in meeting HACCP (Hazardous Analysis and Critical Control Point) procedures and stringent plant cleaning requirements including both CIP (Clean in Place) and SIP (Steam in Place).

CRES — Flexibility of Choice

As environmental and performance requirements change from application to application a single bearing design may not be the most economical choice. Emerson Power Transmission's family of CRES bearing products can help you align the optimal solution to specific requirements. This flexibility of choice will assist in meeting food safety industry requirements and reduce your total operating cost.

The Sealmaster, Browning and McGill family of CRES bearing products is your answer to your corrosion resistance problems.



CRES Bearings



Bearing Products	
Corrosion Basics	8-9
Material Basics	10-11
Product Selection	12-13

CRES Cam Followers	
McGill CRES CAMROL®	14-19

CRES Mounted Roller Bearings	
Sealmaster RPB-CR	20-29

CRES Mounted Mounted Ball Bearings	
Sealmaster CR Gold	30-35
Sealmaster PN Gold™	36-57
Sealmaster CRX-TREME	58-69
Browning CRES CZ	70-75
Browning CRES CS	76-81
Browning CRES SS	82-87
Sealing and Sealing Accessories	88-91
Housing Material	92-93

Lubrication	94-95
Speed and Load Charts	96-98

BEARINGS

Corrosion Resistant Engineered Solutions



Why Does Corrosion Occur?

Corrosion is the deterioration of a materials properties due to a chemical or electrochemical reaction with it's environment. Corrosion is a leading cause of bearing problems.

Bearing replacement due to corrosion can be based on visual or performance factors.

- Visual factors relate to the aesthetics of the bearing and potential for corrosion runoff onto the product being processed. In certain applications this is unacceptable due to health or cleanliness standards.
- Performance factors relate to how excessive corrosion may prevent the bearing from rotating properly. The corrosion that occurs can lead to seal degradation, contamination ingress or internal component wear leading to bearing seizure.

The rate of corrosion depends on application conditions and material.

Chemicals

Both the chemical composition and/or pH levels can impact the rate of corrosion. Consideration must be given to both process and cleaning materials that come in contact with the bearing.

Contact Method

The type of contact a material has with the chemical can have a significant impact on the rate of corrosion. Whether a material is exposed to high-pressure spray, light flow or a fog condition, the corrosion rate can vary greatly.

Environment and Atmosphere

Increased levels of humidity, oxygen content and temperature can accelerate corrosion rates. In addition, cycles of equipment operation can impact overall bearing performance.

Corrosion Basics

Standard Chemical pH

The chart below offers general guidelines on the pH level of common foods, beverages and chemicals to help you choose an appropriate bearing material.

Strong Acid 0-3 pH	Mild Acid 4-6 pH	Neutral 7 pH	Mild Base 8-10 pH	Strong Base 11-14 pH
Hydrochloric Acid	Tomatoes	Distilled Water	Seawater	Ammonia
Hydrofluoric Acid	Boric Acid	Shrimp	Calcium Chloride	Sodium Silicate
Battery Acid	Hydrogen Sulfide	Corn Oil	Soaps, Shampoo	Sodium Cyanide
Sulfuric Acid	Beer	Sugar	Sodium Acetate	Sodium Carbonate
Nitric Acid	Ammonium Chloride	Trichloroethylene	Sodium Bicarbonate	Sodium Phosphate
Phosphoric Acid	Rain Water	Acetone	Baking Soda	Chlorine
Vinegar	Coffee	Blood	Detergents	Bleach
Hydrogen Peroxide	Meat, Pork, Poultry		Sodium Sulphate	Sodium Hypochlorite
Acetic Acid	Dairy Products		Sodium Sulfite	Caustic Soda
Soft Drinks	Sodium Chloride, Salt		Magnesium Hydroxide	Sodium Hydroxide, Lye
Citric Acid	Seafood			Drain Cleaner
Fruit Juices	Fertilizer			Potassium Hydroxide
Pickle Brine	Vegetables			
Lactic Acid	Bread			
Wine				
Sport Drinks				
Benzoic Acid				

BEARINGS

Corrosion Resistant Engineered Solutions



Material Basics

CRES bearing products utilize a variety of materials and coatings. Each material offers various levels of load capacity and resistance to wear and corrosion. To better understand visual performance characteristics, EPT engineers have tested these materials in various conditions. Shown below are the materials in an untested state and after exposure to an acid and basic chemical.

52100 Bearing Steel

- Common bearing material
- Good load capacity and wear resistance
- Minimal corrosion resistance

Black Oxide

- Common bearing steel with oxidized surface
- Marginal improvement to corrosion resistance compared to 52100 bearing steel
- Minimal corrosion resistance compared to coatings or stainless steel

Zinc Dichromate Coating

- 52100 bearing steel coated with zinc dichromate
- If scratched or damaged, the coating will sacrificially corrode to protect the base material
- Zinc coatings are more prone to deteriorate than barrier coatings

Thin Dense Chrome (TDC)

- 52100 bearing steel with a thin barrier coating
- Good wear and abrasion resistance
- May not hold up as well as thicker coatings over time











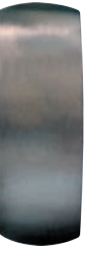

Material	Acid Test	Basic Test

Material Basics

Materials were exposed for 8 hours to the test chemical followed by a dry period of 16 hours. This test was repeated six times for acid condition and twice for basic condition.

Acid test condition: citric acid, pH 2, 48 hours chemical exposure.

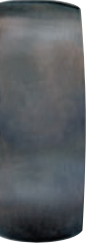
Basic test condition: chlorine bleach, 6% concentration, pH 12, 16 hours chemical exposure.

Material	Acid Test	Basic Test	
			Nickel with TEFLON® (PTFE) <ul style="list-style-type: none">• 52100 bearing steel with a thin barrier coating of nickel with thick PTFE overcoat• Holds up better than thinner coatings over time• If scratched, barrier coating may not protect base material
			Phosphorus Nickel <ul style="list-style-type: none">• 52100 bearing steel with a thick barrier coating of high phosphorus electroless nickel• Holds up better than thinner coatings over time• If scratched, barrier coatings may not protect base material
			400 Series Stainless Steel <ul style="list-style-type: none">• Martensitic stainless steel• Hardens for good load capacity and wear resistance• Not as durable as 52100 bearing steel or as corrosion resistant as 300 Series stainless steel
			300 Series Stainless Steel <ul style="list-style-type: none">• Austenitic stainless steel• Excellent corrosion resistance• Cannot be hardened for improved load capacity or wear resistance

*TEFLON is a registered trademark of the DuPont Company.

BEARINGS

Corrosion Resistant Engineered Solutions



Cam Follower



Product	Material		Overall Corrosion Resistance*		
	Inner and Outer Material	Rolling Element Material	Low pH	Neutral pH	High pH
CAMROL Standard	Black Oxide 52100 Steel	52100 Steel	✓	✓	✓
CRES CAMROL	440C Stainless Steel	440C Stainless Steel	✓✓✓✓	✓✓✓✓	✓✓✓✓

Mounted Roller Bearing



Product	Material			Overall Corrosion Resistance*		
	Inner and Outer Material (a)	Rolling Element Material	Housing Material	Low pH	Neutral pH	High pH
RPB Series (Tapered Roller)	Black Oxide 52100 Steel	Alloy Steel	Painted Cast Iron	✓	✓	✓
SPB1000 Series (Spherical Roller)	Alloy Steel	Alloy Steel	Painted Cast Iron	✓	✓	✓
RPB-CR Series (Tapered Roller)	Black Oxide 52100 Steel	Alloy Steel	Fluoropolymer Coated Cast Iron	✓✓	✓✓	✓✓

(a) RPB Inner Ring 52100 steel.

Mounted Ball Bearing



Product	Material			Overall Corrosion Resistance*		
	Inner and Outer Material (a)	Rolling Element Material	Housing Material	Low pH	Neutral pH	High pH
CRES CZ	Zinc Dichromate Coated 52100 Steel	52100 Steel	High Strength Composite	✓✓	✓✓	✓✓
CRES CS	440C Stainless Steel	440C Stainless Steel	High Strength Composite	✓✓✓✓	✓✓✓✓	✓✓✓✓
CRES SS	440C Stainless Steel	440C Stainless Steel	304 Stainless Steel	✓✓✓✓	✓✓✓✓	✓✓✓✓
CR GOLD	Black Oxide 52100 Steel	52100 Steel	316 Stainless Steel	✓	✓	✓
PN GOLD (Stainless Housing)	Phosphorus Nickel Coated 52100 Steel	440C Stainless Steel	316 Stainless Steel	✓✓✓✓	✓✓✓	✓✓✓
PN GOLD (Composite Housing)	Phosphorus Nickel Coated 52100 Steel	440C Stainless Steel	High Strength Composite	✓✓✓✓	✓✓✓	✓✓✓
CRX-TREME (Stainless Housing)	Custom Stainless Steel	440C Stainless Steel	316 Stainless Steel	✓✓✓✓✓	✓✓✓✓✓	✓✓✓✓✓
CRX-TREME (Composite Housing)	Custom Stainless Steel	440C Stainless Steel	High Strength Composite	✓✓✓✓✓	✓✓✓✓✓	✓✓✓✓✓

Legend: ✓ = Worst
 ✓✓✓✓ = Best

Values listed in the mounted ball, mounted roller and cam follower charts are general guidelines to assist in bearing selection, as compared against the other products listed in the range. They are not comparable across product lines. User testing and evaluation is strongly suggested to determine which product will best meet specific conditions and requirements.

*The overall corrosion resistance values listed are general guideline on material performance based on our laboratory testing. Material performance can vary based on the specific chemicals used, contact method and environmental factors and cannot be reliably predicted for every condition combination. For more information please refer to EPT Bearing Application Engineering at 219-465-2211.

For load and speed limitations refer to pages 17 and 19 for cam followers and pages 96-98 for mounted bearings.

Product Selection

Sealing Effectiveness		Unit Performance Factors		Page Number
High Pressure Spray	Particle Contaminate Resistance	Relative Load Ratings**	Speed Capability	
✓✓	✓✓✓	✓✓✓✓✓	✓✓✓	None
✓✓✓✓	✓✓✓✓	✓✓✓	✓✓✓	Pages 14-19

Sealing Effectiveness (b)		Unit Performance Factors			Page Number
High Pressure Spray	Particle Contaminate Resistance	Relative Load Ratings**	Housing Strength	Speed Capability	
✓✓	✓✓	✓✓✓✓	✓✓✓	✓✓✓	None
✓	✓	✓✓	✓✓✓	✓✓✓✓	None
✓✓	✓✓	✓✓✓✓	✓✓✓	✓✓✓	Pages 20-29

b) Industry standard offers a labyrinth seal design.

Sealing Effectiveness		Unit Performance Factors			Page Number
High Pressure Spray	Particle Contaminate Resistance	Relative Load Ratings**	Housing Strength	Speed Capability	
✓✓✓	✓✓	✓✓✓✓✓	✓✓✓	✓✓✓	Pages 70-75
✓✓	✓	✓✓✓	✓✓✓	✓✓	Pages 76-81
✓✓	✓	✓✓✓	✓✓✓✓✓	✓✓	Pages 82-87
✓	✓✓✓	✓✓✓✓✓	✓✓✓✓✓	✓✓✓✓	Pages 30-35
✓✓✓✓✓	✓✓✓✓✓	✓✓✓✓	✓✓✓✓✓	✓✓	Pages 42-49
✓✓✓✓✓	✓✓✓✓✓	✓✓✓✓	✓✓✓	✓✓	Pages 50-57
✓✓✓✓✓	✓✓✓✓✓	✓✓✓	✓✓✓✓✓	✓✓	Pages 62-65
✓✓✓✓✓	✓✓✓✓✓	✓✓✓	✓✓✓	✓✓	Pages 66-69

Legend: ✓ = Worst
 ✓✓✓✓✓ = Best

**Relative load rating for mounted ball and cam followers takes into consideration life adjustments (derate factors) for bearing raceways and rolling element materials. ABMA recommends a material derate factor for 440C stainless steel. For more information on life adjustment factors refer to page 178 of Sealmaster catalog BP-97. Roller bearing relative load rating compares basic dynamic ratings at the same number of theoretical cycles.

BEARINGS

Corrosion Resistant Engineered Solutions



CRES CAMROL *Stainless Steel Cam Follower*

In addition to the standard McGill cam follower features, CRES CAMROL bearings utilize stainless steel materials. LUBRI-DISC® + seals and H1 food grade grease. This design incorporates aerospace technology to help prolong bearing life in a variety of corrosive environments.



Nomenclature:

CFE - 1 1/2 - SB - CR

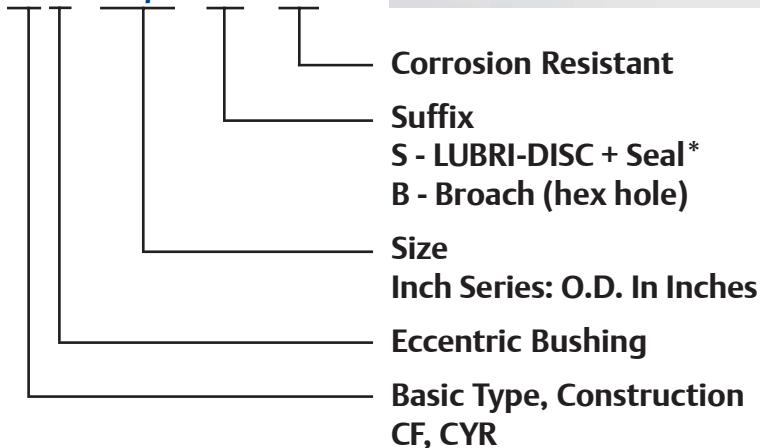

* LUBRI-DISC + Seal is used on bearings with a 1 inch O.D. and larger. Smaller sizes use standard LUBRI-DISC Seals.

Cam Follower Bearings

Components Material

Bearing Races:	440C Stainless Steel
Needles:	440C Stainless Steel
Seal:	LUBRI-DISC + Seal*
Grease:	H1 Food Grade Grease

Features and Benefits

440C Stainless Steel:	More corrosion resistant than common bearing steel.
Zone Hardened Raceway:	Provides a hardened raceway for load capacity and stem ductility for absorbing shock loads.
LUBRI-DISC + Seal:	Improved contamination resistance and lubrication retention.
H1 Food Grade Grease:	Non-toxic grease with good corrosion resistance and wash out properties.

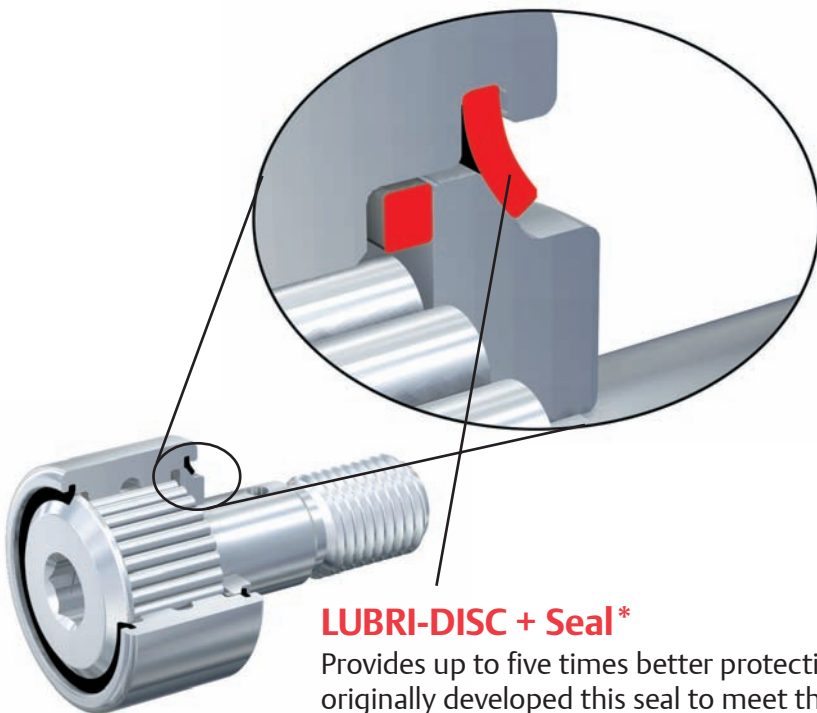

LUBRI-DISC + Seal*

Provides up to five times better protection against washdown than standard seals. McGill originally developed this seal to meet the tough demands of aerospace applications.

* LUBRI-DISC + Seal is used on bearings with a 1 inch O.D. and larger. Smaller sizes use standard LUBRI-DISC Seals.

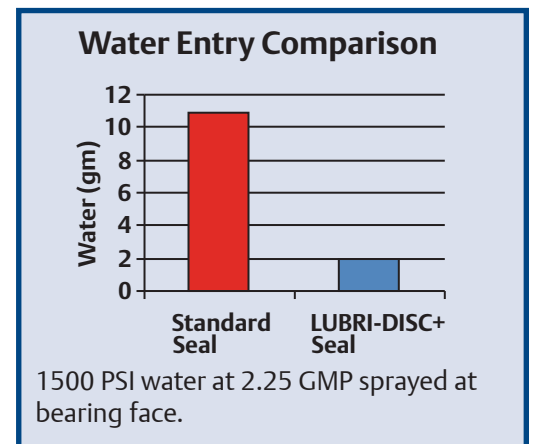

BEARINGS

Corrosion Resistant Engineered Solutions





Standard Stud



Eccentric Stud

CF-SB-CR, CFE-SB-CR

Description	RD	W	SD	SL	C	TL	Thread Type	HC	HD	F
	Roller Diameter +.0000 -.0010	Roller Width +.000 -.005	Stud Diameter +.001 -.000	Stud Length (Ref.)	Endplate Extension (Ref.)	Minimum Thread Length		Radial Lub. Hole Center	Radial Lub. Hole Diameter	Lub. Hole Dia./Lub. Fitting
CF-1/2-SB-CR	.5000	.375	.190	5/8	1/32	1/4	10-32	-	-	-
CF-9/16-SB-CR	.5625							-	-	-
CF-5/8-SB-CR	.6250	.438	.250	3/4		5/16	1/4-28	-	-	-
CF-11/16-SB-CR	.6875							-	-	-
CF-3/4-SB-CR	.7500	.500	.375	7/8		3/8	3/8-24	1/4	3/32	3/16
CF-7/8-SB-CR	.8750									
CF-1-SB-CR	1.0000	.625	.438	1		1/2	7/16-20	5/16		
CF-1 1/8-SB-CR	1.1250									
CF-1 1/4-SB-CR	1.2500	.750	.500	1 1/4		5/8	1/2-20	3/8		
CF-1 3/8-SB-CR	1.3750									
CF-1 1/2-SB-CR	1.5000	.875	.625	1 1/2		3/4	5/8-18	7/16		
CF-1 5/8-SB-CR	1.6250									
CF-1 3/4-SB-CR	1.7500	1.000	.750	1 3/4		7/8	3/4-16	1/2		
CF-1 7/8-SB-CR	1.8750									
CF-2-SB-CR	2.0000	1.250	.875	2		1	7/8-14	1/2	1/8	

Note: For Eccentric stud add an "E". Example: CFE-1/2-SB-CR

Cam Follower Bearings

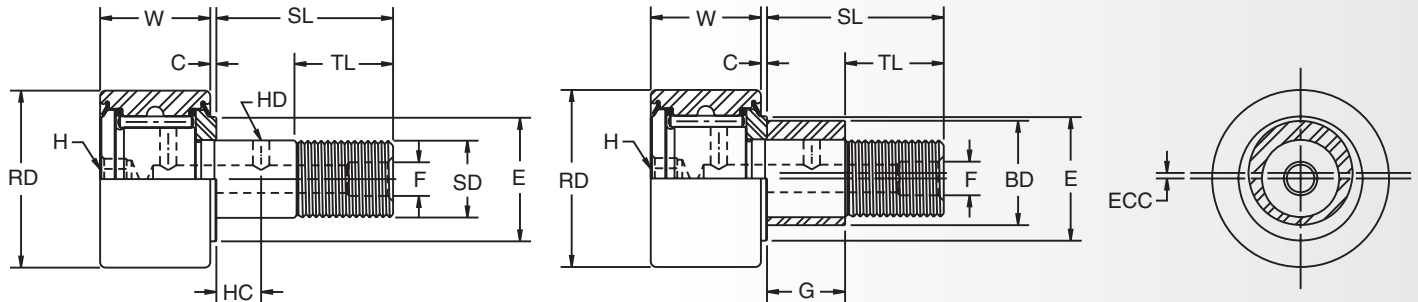

CF-2-SB-CR
CF-2-SB-CR Shown*

CFE-2-SB-CR
CFE-2-SB-CR Shown*

CF-SB-CR, CFE-SB-CR

Mounting Dimensions							Load Ratings				Description
E	H	Housing Bore Diameter +.0002 -.0003	Eccentric Bushing Only		ECC.	Housing Bore Diameter +/- .001	Clamping Torque (Lbs.-In.) (1)	Limiting Speed with Grease (RPM) (2)	Track Roller Dynamic Rating (Lbs.) (3)	Track Roller Static Rating (Lbs.) (4)	
Min. Clamping Diameter (Ref.)	Hex Wrench Size		BD	G							
19/64	1/8	.1903	.250	.375	.010	.253	8	11500	610	300	CF-1/2-SB-CR
23/64		.2503	.375	.437	.015	.378	18	10000			CF-9/16-SB-CR
								9200	860	600	CF-5/8-SB-CR
								8300			CF-11/16-SB-CR
1/2	3/16	.3753	.500	.500	.015	.503	48	6400	1490	1500	CF-3/4-SB-CR
41/64	1/4	.4378	.625	.625	.030	.628	125	4800	2000	1800	CF-1-SB-CR
49/64		.5003	.687	.690	.030	.690	175	3100	3530	2300	CF-1 1/4-SB-CR
57/64	5/16	.6253	.875	.878	.030	.878	325	2500	4350	4000	CF-1 1/2-SB-CR
1 3/64		.7503	1.000	1.003	.030	1.003	625	2200	5730	6000	CF-1 3/4-SB-CR
1 13/64	7/16	.8753	1.187	1.000	.030	1.190	750	1400	7270	8200	CF-2-SB-CR

*LUBRI-DISC + Seal is used on bearings with 1 inch O.D. and larger. Smaller sizes use standard LUBRI-DISC Seals.

Note: For Eccentric stud add an "E". Example: CFE-1/2-SB-CR

(1) Clamping torque is based on lubricated threads. If threads are dry, double the value listed.

(2) Since load, lubrication method, temperature and other factors affect the maximum operating speed, it is impossible to determine precise limiting speeds. The listed limiting speeds are based on lightly loaded bearings having adequate lubrication and are listed only as a design guide. More frequent relubrication is required when operating at higher speeds. Actual bearing testing in the specific application should be conducted if the operating speed approaches the listed limiting speed.

(3) Use track roller dynamic load rating for life calculations. Maximum dynamic load should not exceed 50% of track roller dynamic load rating. If radial load and/or root mean load exceed 50% of track roller dynamic load rating, life calculations must be reviewed by McGill Engineering. If dynamic loads exceed 25% of basic dynamic rating, consideration should be given to use of CYR CRES series CAMROL bearing. For more information please contact EPT bearing engineering at McGill.Engineering@emerson-ept.com.

(4) The track roller static load rating is based on stud strength. Exceeding the static load rating may impair subsequent dynamic operation.

BEARINGS

Corrosion Resistant Engineered Solutions





Cam Yoke Roller

CYR-S-CR

Description	RD	W	B	C	W1	HD
	Roller Diameter +.0000 -.0010	Roller Width +.000 -.005	Bore +.0002 -.0004	Endplate Extension (Ref.)	Overall Width +.0050 -.0100	Radial Lub. Hole Diameter
CYR-3/4-S-CR	.7500	.500	.2500	1/32	.5625	3/32
CYR-7/8-S-CR	.8750					
CYR-1-S-CR	1.0000	.625	.3125		.6875	
CYR-1 1/8-S-CR	1.1250					
CYR-1 1/4-S-CR	1.2500	.750	.3750		.8125	
CYR-1 3/8-S-CR	1.3750					
CYR-1 1/2-S-CR	1.5000	.875	.4375		.9375	
CYR-1 5/8-S-CR	1.6250					
CYR-1 3/4-S-CR	1.7500	1.000	.5000		1.0625	
CYR-1 7/8-S-CR	1.8750					
CYR-2-S-CR	2.0000	1.250	.6250	1.3125		

Cam Follower Bearings

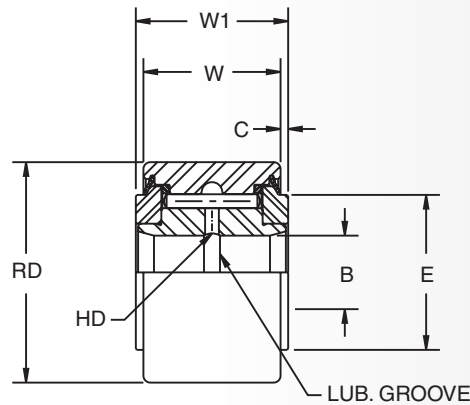

CYR-2-S-CR
CYR-2-S-CR Shown*

CYR-S-CR

Mounting Dimensions				Limiting Speed with Grease (RPM) (1)	Load Ratings		Description
E	Shaft Diameter				Track Roller Dynamic Rating (Lbs.) (2)	Track Roller Static Rating (Lbs.)	
	Push Fit	Drive Fit	Press Fit				
Min. Clamping Diameter (Ref.)	Nom. +/- .0002	Nom. +/- .0002	Nom. +/- .0002				
1/2	.2495	.2501	.2503	6400	1490	2100	CYR-3/4-S-CR
				5400			CYR-7/8-S-CR
41/64	.3120	.3126	.3128	4800	2000	5400	CYR-1-S-CR
				3400			CYR-1 1/8-S-CR
49/64	.3745	.3751	.3753	3100	3530	7700	CYR-1 1/4-S-CR
				2800			CYR-1 3/8-S-CR
57/64	.4370	.4376	.4378	2500	4350	11200	CYR-1 1/2-S-CR
				2350			CYR-1 5/8-S-CR
1 3/64	.4995	.5001	.5005	2200	5730	14800	CYR-1 3/4-S-CR
				2000			CYR-1 7/8-S-CR
1 13/64	.6245	.6251	.6251	1400	7270	17600	CYR-2-S-CR

*LUBRI-DISC + Seal is used on bearings with 1 inch O.D. and larger. Smaller sizes use standard LUBRI-DISC Seals.

(1) Since load, lubrication method, temperature and other factors affect the maximum operating speed, it is impossible to determine precise limiting speeds. The listed limiting speeds are based on lightly loaded bearings having adequate lubrication and are listed only as a design guide. More frequent relubrication is required when operating at higher speeds. Actual bearing testing in the specific application should be conducted if the operating speed approaches the listed limiting speed.

(2) Use track roller dynamic load rating for life calculations. Maximum dynamic load should not exceed 50% of track roller dynamic load rating. If radial load and/or root mean load exceed 50% of track roller dynamic load rating, life calculations must be reviewed by McGill Engineering.

BEARINGS

Corrosion Resistant Engineered Solutions



CRES RPB-CR *Mounted Roller Bearings*

In addition to the Sealmaster standard platform features, RPB-CR bearings offer a fluoropolymer coating cast iron housing, single lip contact seal and H1 food grade grease.



Nomenclature:

RPBA - 103 - C2 CR

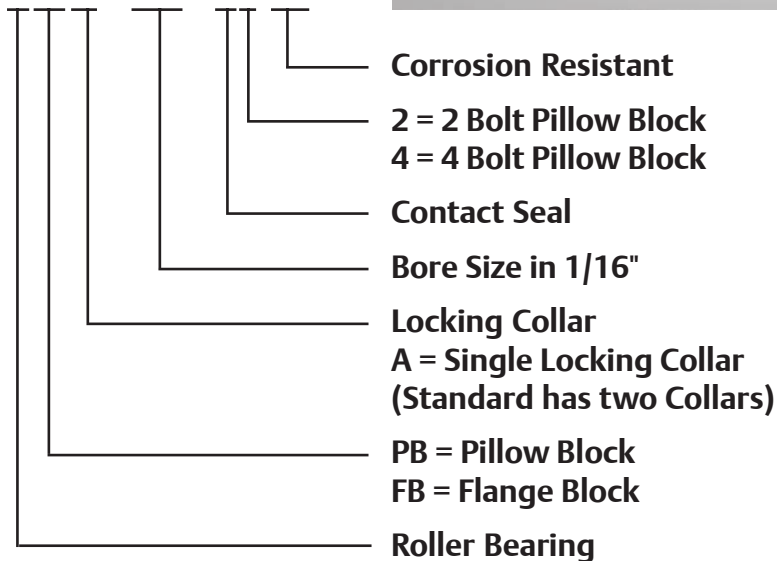

Mounted Roller Bearings

Components Material

Housing:	Fluoropolymer Coated Cast Iron
Outer Race:	Black Oxide 52100 Steel
Inner Race:	52100 Steel
Retainer:	Low Carbon Steel
Seal:	Single Lip Rubber Contact Seal
Washer:	300 Series Stainless Steel
Housing Bolts:	Fluoropolymer Coated
Grease Fitting:	300 Series Stainless Steel
Set Screws:	Black Oxide Steel Diamond Faceted Cup Point
Lock Collars:	Fluoropolymer Coated
Grease:	Sealmaster® GoldPlex™-FG

Features and Benefits

Insert

Tapered Roller Bearing Design:	Offers good capacity for radial or combined loading conditions.
Replaceable Cartridge Insert:	Ease of replacement, provides proper roller contact with the races and accommodates +/- 3° static misalignment.
Fluoropolymer Coated Locking Collars:	Improved corrosion resistance.
Single Lip Rubber Contact Seal:	Race mounted design for improved resistance to contamination and lubrication retention.
Alignment Pin:	Prevents outer race rotation of the cartridge insert.
Positive Lubrication System:	Allows direct lubrication into the bearing.
H1 Food Grade Grease:	Non-toxic grease with superior corrosion resistance and excellent wash out properties.

Housing

Fluoropolymer Coated Housing:	Non-stick coating offers resistance to chemicals and performs better than painted or nickel coated housings in our testing.
Cast Iron Split Housing Construction:	Allows for replacement of bearing insert.
Fluoropolymer Coated Cap Bolts:	Improved corrosion resistance.
Aluminum Nameplate:	Brand and nomenclature marking.

BEARINGS

Corrosion Resistant Engineered Solutions



We begin with the best... and then improve the design to the most demanding specific services.

The RPB series bearings are used in applications where they may be subjected to moisture, corrosive and abrasive environments.

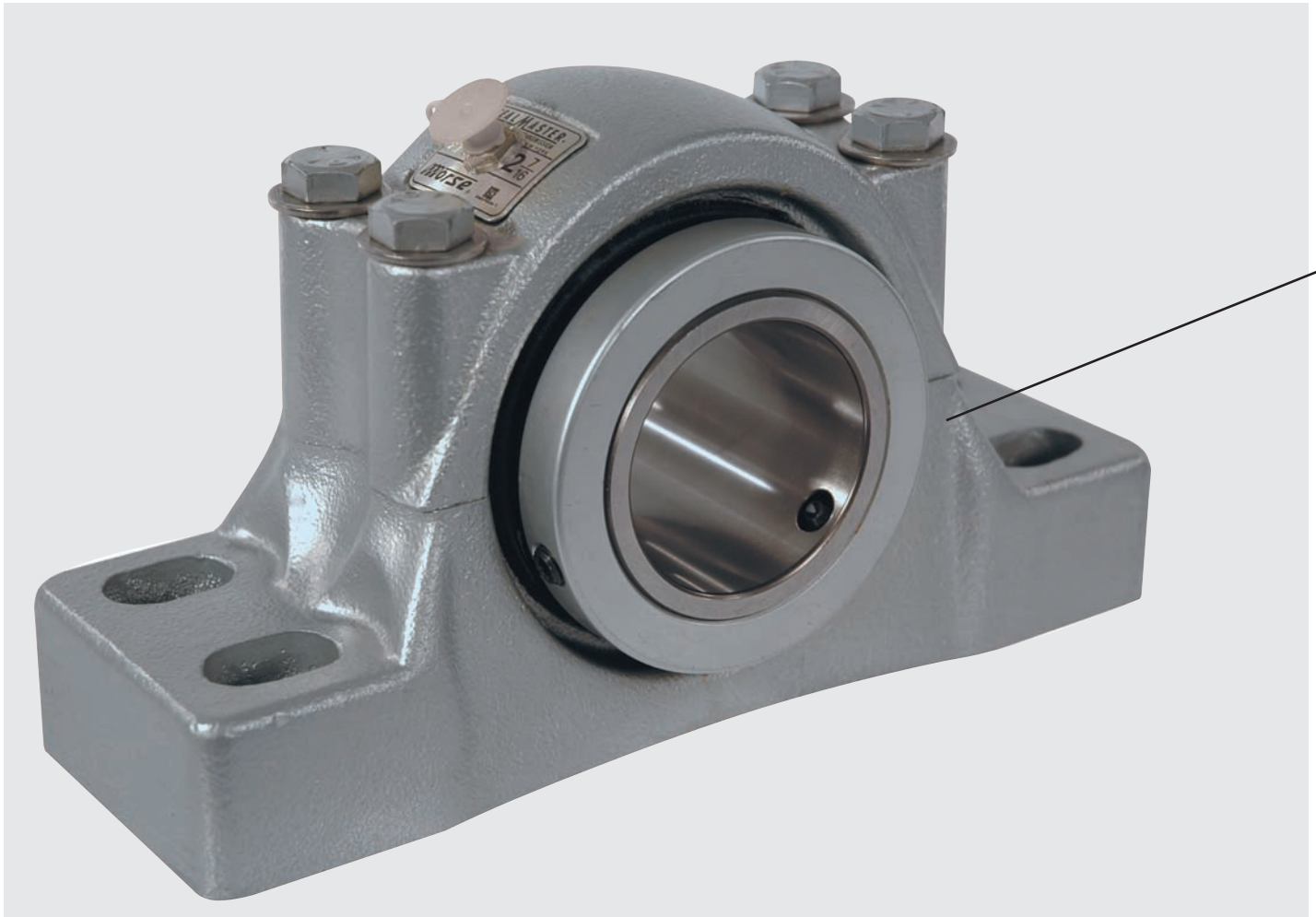

Mounted Roller Bearings

Fluoropolymer Housing

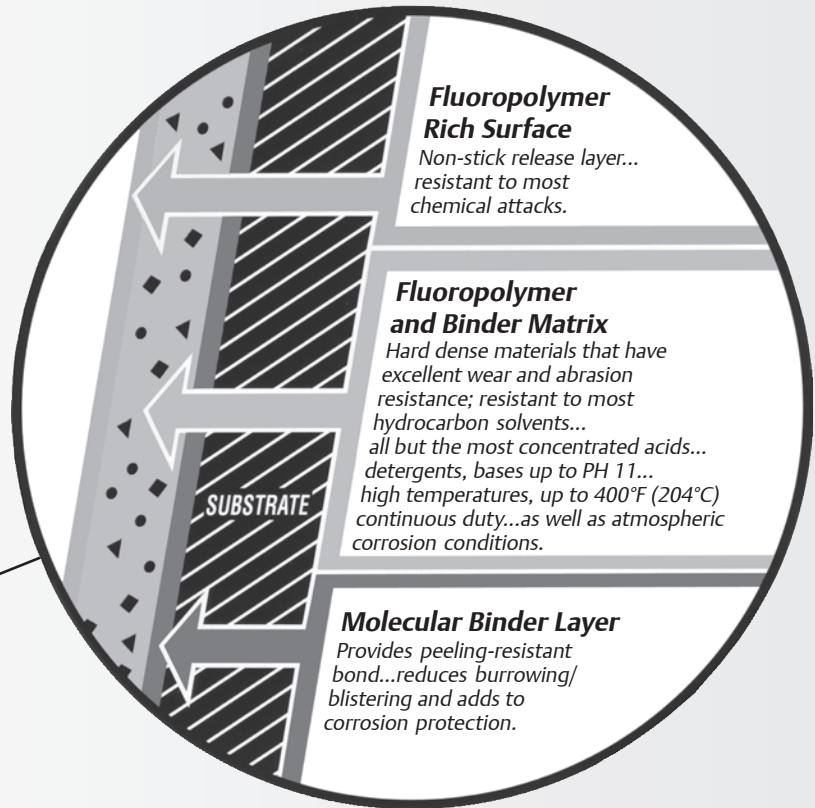

		HOUSING COATING PERFORMANCE CHART						
		CORROSION CHARACTERISTICS	SEALMASTER CORROSION DUTY	PAINT	ELECTROLESS NICKEL	CU/NI/CR	NYLON	TEFLON*
The chart to the right demonstrates the effectiveness of this corrosion-resistant polymer coating for a variety of atmospheric conditions and other physical qualities, against other popular materials. It is also important to note that SEALMASTER CR Duty Bearings have the housing bores coated	ACID	✓✓✓✓	✓	✓✓✓	✓✓	✓✓✓	✓✓✓✓	
	BASE	✓✓✓✓	✓	✓✓	✓✓	✓✓✓	✓✓✓✓	
	WASHDOWN	✓✓✓✓	✓	✓✓	✓✓	✓✓✓	✓**	
	ATMOSPHERIC EXPOSURE	✓✓✓✓	✓✓	✓✓	✓✓	✓✓	✓✓✓✓	
	NON-STICK	✓✓✓✓	-	-	-	✓	✓✓✓✓	
	ADHESION TO CASTING	✓✓✓✓	✓✓✓	✓✓✓	✓✓✓	✓✓✓	✓	
	HARDNESS	✓✓✓	✓✓	✓✓✓✓	✓✓✓✓	✓✓✓	✓	
	COLOR	✓✓✓✓	✓	✓✓	✓✓	✓✓✓✓	✓✓	
	EXCELLENT	✓✓✓✓	FAIR	✓✓	UNACCEPTABLE	-	* Teflon is a registered trademark of the Du Pont Company.	
	GOOD	✓✓✓	POOR	✓	** SHOULD NOT BE USED WITH HIGH PRESSURE SPRAYWASH			

Contact EPT Customer Service at 1-800-626-2120 for availability on additional configurations such as: RFB, RPBXT and all expansion bearings.

BEARINGS

Corrosion Resistant Engineered Solutions





Two Bolt Base



Four Bolt Base

RPB-CR Series Pillow Blocks... Two Bolt Base

Part Description	Shaft Dia. In.	Dimensions in inches										Base Bolts	
		A	B	C		D	E	G	H	J	L	No.	Size
				Min.	Max.								
RPB-103-C2 CR	1 3/16	1 1/2	6 17/64	4 9/16	4 15/16	1 7/8	-	7/8	3 1/8	2 3/4	2 1/4	2	1/2
RPB-104-C2-CR	1 1/4			4 9/16	4 15/16								
RPB-106-C2 CR	1 3/8	1 7/8	7 1/4	5 5/16	5 15/16	2 1/16	-	1 1/8	3 13/16	3	2 5/8	2	1/2
RPB-107-C2 CR	1 7/16			5 5/16	5 15/16								
RPB-108-C2 CR	1 1/2	2 1/8	7 3/4	5 9/16	6 7/16	2 5/16	-	1 1/4	4 3/8	3 3/8	2 7/8	2	1/2
RPB-110-C2 CR	1 5/8			5 9/16	6 7/16								
RPB-111-C2 CR	1 11/16												
RPB-112-C2 CR	1 3/4	2 1/4	8 7/8	6 5/16	7 3/16	2 7/16	-	1 1/4	4 5/8	3 1/2	3 1/4	2	5/8
RPB-115-C2 CR	1 15/16			6 5/16	7 3/16								
RPB-200-C2 CR	2												
RPB-203-C2 CR	2 3/16	2 1/2	9 5/8	6 11/16	7 15/16	2 9/16	-	1 7/16	5 1/8	3 3/4	3 5/8	2	5/8
RPB-204-C2 CR	2 1/4	2 3/4	10 3/8	6 15/16	8 11/16	2 3/4	-	1 5/8	5 5/8	4	3 15/16	2	5/8
RPB-207-C2 CR	2 7/16			6 15/16	8 11/16								
RPB-208-C2 CR	2 1/2												
RPB-211-C2 CR	2 11/16	3 1/8	11 3/4	8 1/16	9 11/16	3	-	1 3/4	6 3/8	4 33/64	4 45/64	2	3/4
RPB-212-C2 CR	2 3/4			8 1/16	9 11/16								
RPB-215-C2 CR	2 15/16												
RPB-300-C2 CR	3												
RPB-303-C2 CR	3 3/16	3 3/4	13 3/4	10 1/8	11 1/4	4 1/8	-	2 1/16	7 3/4	5 1/64	5 7/16	2	7/8
RPB-307-C2 CR	3 7/16			10 1/8	11 1/4								
RPB-308-C2 CR	3 1/2												

Mounted Roller Bearings

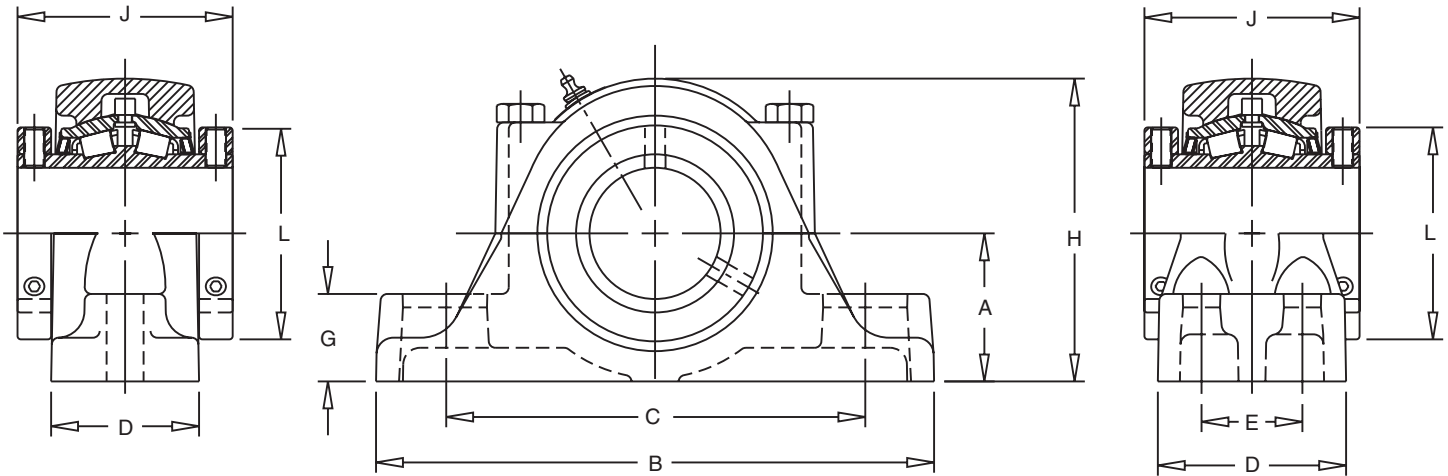

TWO BOLT BASE

FOUR BOLT BASE

RPB-CR Series Pillow Blocks... Four Bolt Base

Part Description	Shaft Dia. In.	Dimensions in inches										Base Bolts	
		A	B	C		D	E	G	H	J	L	No.	Size
				Min.	Max.								
RPB-204-C4 CR	2 1/4												
RPB-207-C4 CR	2 7/16	2 3/4	10 3/8	7 3/4	8 3/4	3 1/2	1 7/8	1 5/8	5 5/8	4	3 15/16	4	5/8
RPB-208-C4 CR	2 1/2												
RPB-211-C4 CR	2 11/16												
RPB-212-C4 CR	2 3/4	3 1/8	11 3/4	8 3/4	10	3 3/4	2 1/8	1 3/4	6 3/8	4 33/64	4 45/64	4	5/8
RPB-215-C4 CR	2 15/16												
RPB-300-C4 CR	3												
RPB-303-C4 CR	3 3/16	3 3/4	13 3/4	10 9/16	11 1/2	4 1/2	2 3/8	2 1/16	7 3/4	5 1/64	5 7/16	4	5/8
RPB-307-C4 CR	3 7/16												
RPB-308-C4 CR	3 1/2												
RPB-315-C4 CR	3 15/16	4 1/4	15 1/4	11	13	4 1/2	2 1/4	2 7/16	8 5/8	6 1/4	5 15/16	4	3/4
RPB-400-C4 CR	4												
RPB-407-C4 CR	4 7/16	4 3/4	16 1/2	11 3/4	13 7/8	4 5/8	2 1/2	2 3/4	9 5/8	6 3/4	6 1/2	4	3/4
RPB-408-C4 CR	4 1/2												
RPB-415-C4 CR	4 15/16	5 1/2	18 1/2	13 1/2	15 7/8	5 1/8	2 3/4	3 1/8	11	7 1/4	7 5/16	4	7/8
RPB-500-C4 CR	5												

BEARINGS

Corrosion Resistant Engineered Solutions





Two Bolt Base

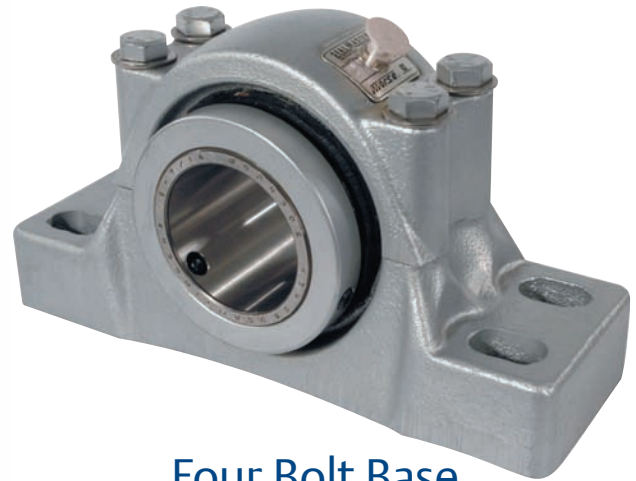

Four Bolt Base

RPBA-CR Series Pillow Blocks... Two Bolt Base

Part Description	Shaft Dia. In.	Dimensions in inches											Base Bolts	
		A	B	C		D	E	G	H	J	K	L	No.	Size
				Min.	Max.									
RPBA-103-C2 CR	1 3/16	1 1/2	6 17/64	4 9/16	4 15/16	1 7/8	-	7/8	3 1/8	2 3/8	1	2 1/4	2	1/2
RPBA-104-C2 CR	1 1/4			4 9/16	4 15/16	1 7/8	-	7/8	3 1/8	2 3/8	1	2 1/4	2	1/2
RPBA-106-C2 CR	1 3/8	1 7/8	7 1/4	5 5/16	5 15/16	2 1/16	-	1 1/8	3 13/16	2 17/32	1 1/32	2 5/8	2	1/2
RPBA-107-C2 CR	1 7/16			5 5/16	5 15/16	2 1/16	-	1 1/8	3 13/16	2 17/32	1 1/32	2 5/8	2	1/2
RPBA-108-C2 CR	1 1/2	2 1/8	7 3/4	5 9/16	6 7/16	2 5/16	-	1 1/4	4 3/8	2 27/32	1 5/32	2 7/8	2	1/2
RPBA-110-C2 CR	1 5/8			5 9/16	6 7/16	2 5/16	-	1 1/4	4 3/8	2 27/32	1 5/32	2 7/8	2	1/2
RPBA-111-C2 CR	1 11/16	2 1/4	8 7/8	6 5/16	7 3/16	2 7/16	-	1 1/4	4 5/8	2 61/64	1 13/64	3 1/4	2	5/8
RPBA-112-C2 CR	1 3/4			6 5/16	7 3/16	2 7/16	-	1 1/4	4 5/8	2 61/64	1 13/64	3 1/4	2	5/8
RPBA-115-C2 CR	1 15/16	2 1/2	9 5/8	6 11/16	7 15/16	2 9/16	-	1 7/16	5 1/8	3 1/8	1 1/4	3 5/8	2	5/8
RPBA-200-C2 CR	2			6 11/16	7 15/16	2 9/16	-	1 7/16	5 1/8	3 1/8	1 1/4	3 5/8	2	5/8
RPBA-203-C2 CR	2 3/16	2 3/4	10 3/8	6 15/16	8 11/16	2 3/4	-	1 5/8	5 5/8	3 5/16	1 5/16	3 15/16	2	5/8
RPBA-204-C2 CR	2 1/4			6 15/16	8 11/16	2 3/4	-	1 5/8	5 5/8	3 5/16	1 5/16	3 15/16	2	5/8
RPBA-207-C2 CR	2 7/16	3 1/8	11 3/4	8 1/16	9 11/16	3	-	1 3/4	6 3/8	3 11/16	1 7/16	4 45/64	2	3/4
RPBA-208-C2 CR	2 1/2			8 1/16	9 11/16	3	-	1 3/4	6 3/8	3 11/16	1 7/16	4 45/64	2	3/4
RPBA-211-C2 CR	2 11/16	3 3/4	13 3/4	10 1/8	11 1/4	4 1/8	-	2 1/16	7 3/4	4 3/16	1 11/16	5 7/16	2	7/8
RPBA-212-C2 CR	2 3/4			10 1/8	11 1/4	4 1/8	-	2 1/16	7 3/4	4 3/16	1 11/16	5 7/16	2	7/8
RPBA-215-C2 CR	2 15/16	3 1/2												
RPBA-300-C2 CR	3													
RPBA-303-C2 CR	3 3/16	3 3/4	13 3/4	10 1/8	11 1/4	4 1/8	-	2 1/16	7 3/4	4 3/16	1 11/16	5 7/16	2	7/8
RPBA-307-C2 CR	3 7/16			10 1/8	11 1/4	4 1/8	-	2 1/16	7 3/4	4 3/16	1 11/16	5 7/16	2	7/8
RPBA-308-C2 CR	3 1/2													

Mounted Roller Bearings

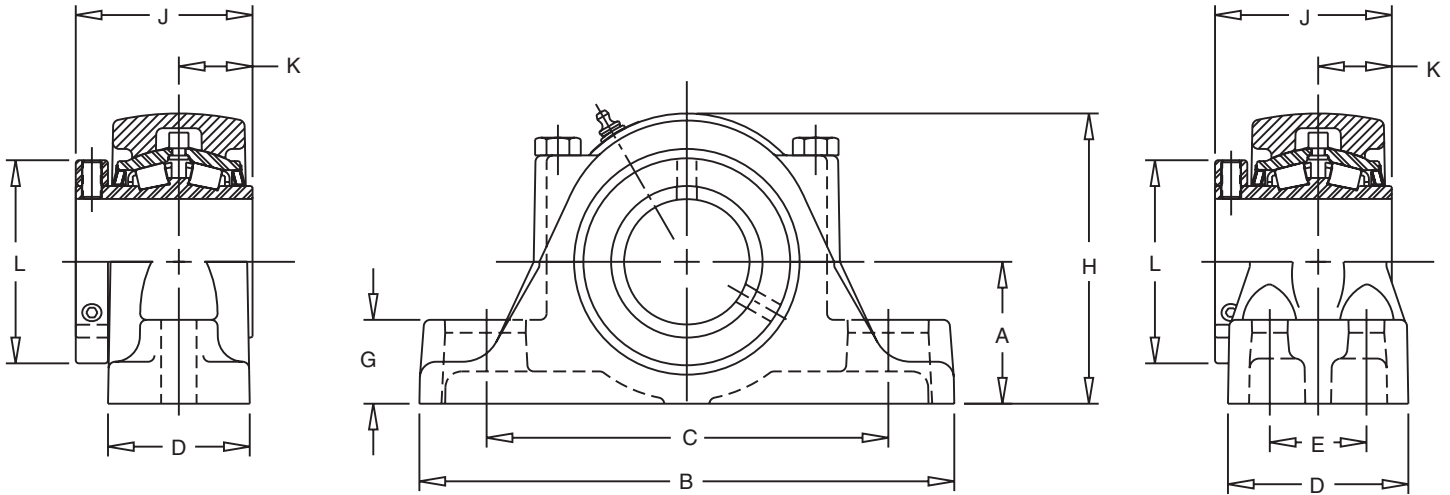

TWO BOLT BASE

FOUR BOLT BASE

RPBA-CR Series Pillow Blocks... Four Bolt Base

Part Description	Shaft Dia. In.	Dimensions in inches											Base Bolts	
		A	B	C		D	E	G	H	J	K	L	No.	Size
				Min.	Max.									
RPBA-204-C4 CR	2 1/4													
RPBA-207-C4 CR	2 7/16	2 3/4	10 3/8	7 3/4	8 3/4	3 1/2	1 7/8	1 5/8	5 5/8	3 5/16	1 5/16	3 15/16	4	5/8
RPBA-208-C4 CR	2 1/2													
RPBA-211-C4 CR	2 11/16													
RPBA-212-C4 CR	2 3/4													
RPBA-215-C4 CR	2 15/16	3 1/8	11 3/4	8 3/4	10	3 3/4	2 1/8	1 3/4	6 3/8	3 11/16	1 7/16	4 45/64	4	5/8
RPBA-300-C4 CR	3													
RPBA-303-C4 CR	3 3/16													
RPBA-307-C4 CR	3 7/16	3 3/4	13 3/4	10 9/16	11 1/2	4 1/2	2 3/8	2 1/16	7 3/4	4 3/16	1 11/16	5 7/16	4	5/8
RPBA-308-C4 CR	3 1/2													
RPBA-315-C4 CR	3 15/16													
RPBA-400-C4 CR	4	4 1/4	15 1/4	11	13	4 1/2	2 1/4	2 7/16	8 5/8	5 1/4	2 1/8	5 15/16	4	3/4
RPBA-407-C4 CR	4 7/16													
RPBA-408-C4 CR	4 1/2	4 3/4	16 1/2	11 3/4	13 7/8	4 5/8	2 1/2	2 3/4	9 5/8	5 1/2	2 1/4	6 1/2	4	3/4
RPBA-415-C4 CR	4 15/16													
RPBA-500-C4 CR	5	5 1/2	18 1/2	13 1/2	15 7/8	5 1/8	2 3/4	3 1/8	11	6 13/64	2 19/32	7 5/16	4	7/8

BEARINGS

Corrosion Resistant Engineered Solutions





RFB-CR Series Flange Units

Part Description	Shaft Dia. in.	Dimensions in inches									
		A	B	C	D	DD	E	F Bolt	H	J	L
RFB-103-C CR	1 3/16	2 13/16	4	2 5/16	2 7/8	4 1/16	1/16	3/8	1	3 1/4	2 1/4
RFB-104-C CR	1 1/4										
RFB-106-C CR	1 3/8	3 1/16	4 5/8	2 9/16	3 1/2	4 15/16	1/16	1/2	1	3 3/4	2 5/8
RFB-107-C CR	1 7/16										
RFB-108-C CR	1 1/2										
RFB-110-C CR	1 5/8	3 1/2	5 3/8	2 15/16	4 1/8	5 13/16	1/8	1/2	1 3/16	4 1/2	2 7/8
RFB-111-C CR	1 11/16										
RFB-112-C CR	1 3/4										
RFB-115-C CR	1 15/16	3 5/8	5 5/8	3 1/16	4 3/8	6 3/16	1/8	1/2	1 3/16	4 3/4	3 1/4
RFB-200-C CR	2										
RFB-203-C CR	2 3/16	3 7/8	6 1/4	3 1/4	4 7/8	6 29/32	1/8	5/8	1 3/8	5 1/4	3 5/8
RFB-204-C CR	2 1/4										
RFB-207-C CR	2 7/16	4 3/16	6 7/8	3 9/16	5 3/8	7 39/64	3/16	5/8	1 1/2	5 3/4	3 15/16
RFB-208-C CR	2 1/2										
RFB-211-C CR	2 11/16										
RFB-212-C CR	2 3/4	4 11/16	7 3/4	3 15/16	6	8 31/64	3/16	3/4	1 5/8	6 1/2	4 23/32
RFB-215-C CR	2 15/16										
RFB-300-C CR	3										
RFB-303-C CR	3 3/16										
RFB-307-C CR	3 7/16	5 1/4	9 1/4	4 1/2	7	9 29/32	15/64	3/4	1 7/8	8	5 7/16
RFB-308-C CR	3 1/2										
RFB-315-C CR	3 15/16	6 1/2	10 1/4	5 5/8	7 3/4	10 61/64	1/4	7/8	2 1/8	8 7/8	5 15/16
RFB-400-C CR	4										

Mounted Roller Bearings

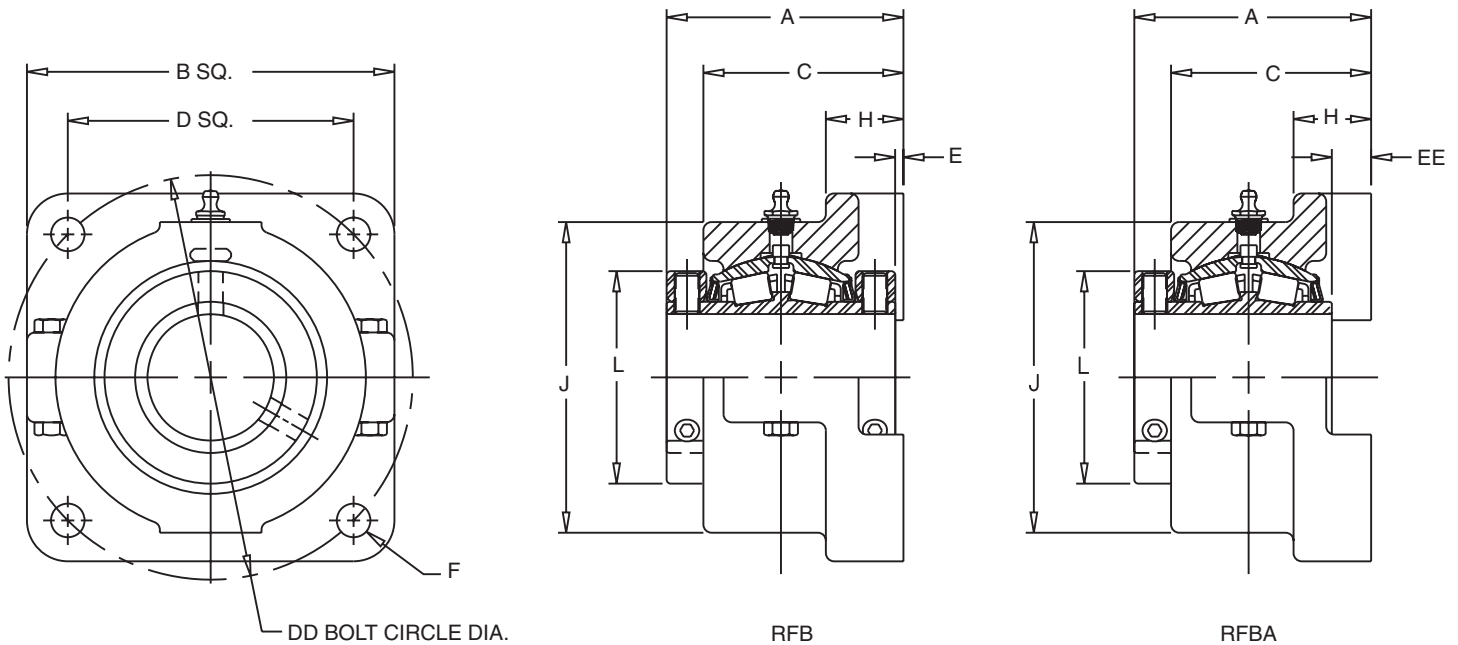

RFBA-CR Series Flange Units

Part Description	Shaft Dia. in.	Dimensions in inches									
		A	B	C	D	DD	EE	F Bolt	H	J	L
RFBA-103-C CR	1 3/16	2 13/16	4	2 5/16	2 7/8	4 1/16	7/16	3/8	1	3 1/4	2 1/4
RFBA-104-C CR	1 1/4										
RFBA-106-C CR	1 3/8	3 1/16	4 5/8	2 9/16	3 1/2	4 15/16	17/32	1/2	1	3 3/4	2 5/8
RFBA-107-C CR	1 7/16										
RFBA-108-C CR	1 1/2										
RFBA-110-C CR	1 5/8	3 1/2	5 3/8	2 15/16	4 1/8	5 13/16	21/32	1/2	1 3/16	4 1/2	2 7/8
RFBA-111-C CR	1 11/16										
RFBA-112-C CR	1 3/4										
RFBA-115-C CR	1 15/16	3 5/8	5 5/8	3 1/16	4 3/8	6 3/16	43/64	1/2	1 3/16	4 3/4	3 1/4
RFBA-200-C CR	2										
RFBA-203-C CR	2 3/16	3 7/8	6 1/4	3 1/4	4 7/8	6 29/32	3/4	5/8	1 3/8	5 1/4	3 5/8
RFBA-204-C CR	2 1/4										
RFBA-207-C CR	2 7/16	4 3/16	6 7/8	3 9/16	5 3/8	7 39/64	7/8	5/8	1 1/2	5 3/4	3 15/16
RFBA-208-C CR	2 1/2										
RFBA-211-C CR	2 11/16										
RFBA-212-C CR	2 3/4	4 11/16	7 3/4	3 15/16	6	8 31/64	1	3/4	1 5/8	6 1/2	4 23/32
RFBA-215-C CR	2 15/16										
RFBA-300-C CR	3										
RFBA-303-C CR	3 3/16										
RFBA-307-C CR	3 7/16	5 1/4	9 1/4	4 1/2	7	9 29/32	1 1/16	3/4	1 7/8	8	5 7/16
RFBA-308-C CR	3 1/2										
RFBA-315-C CR	3 15/16										
RFBA-400-C CR	4	6 1/2	10 1/4	5 5/8	7 3/4	10 61/64	1 1/4	7/8	2 1/8	8 7/8	5 15/16

BEARINGS

Corrosion Resistant Engineered Solutions



CRES CR Gold *Mounted Ball Bearings*

In addition to the Sealmaster standard platform features, CR Gold bearings offer a stainless steel housing, black oxide insert, single lip contact seal and H1 food grade grease.



Nomenclature:

NP - 16C CR

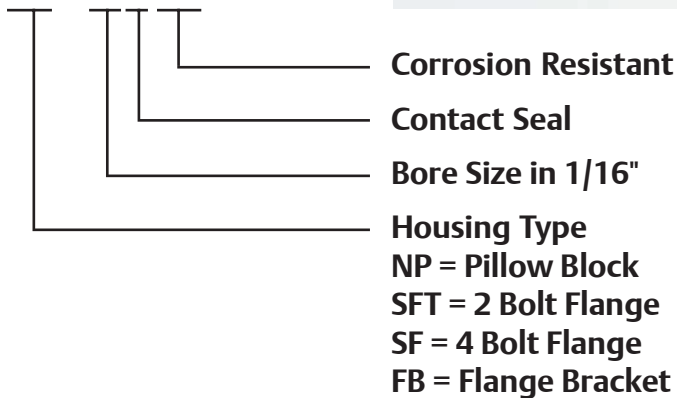

Mounted Ball Bearings

Components Material

Housing:	316 Passivated Stainless Steel
Bearing Races:	Black Oxide 52100 Steel
Balls:	52100 Steel
Retainer:	Unique Metal Land Riding Retainer
Seal:	Single Lip Rubber Contact Seal
Set Screws:	Black Oxided Steel Diamond Faceted Cup Point
Grease Fitting:	303 Stainless Steel
Grease:	Sealmaster GoldPlex-FG

Features and Benefits

Insert

Black Oxided Races:	Marginal improvement to corrosion resistance compared to 52100 steel.
Single Lip Rubber Contact Seal:	Contamination avoidance and lubrication retention.
Wide Outer Race Design:	Extra grease capacity.
Zone Hardened Inner Race:	Improved locking reliability.
Unique Metal Land Riding Retainer:	Corrosion resistant, improves lubrication circulation.
Lock Pin and Dimple System:	Provides direct lubrication path and +/-2° static misalignment and prevents outer race rotation.
H1 Food Grade Grease:	Non-toxic grease with superior corrosion resistance and excellent wash out properties.

Housing

316 Passivated Stainless Steel:	Highest amount of corrosion resistance currently available for stainless steel bearing housings.
Advanced Casting Technology:	Investment cast process yields a smooth, easy to clean surface.
Solid Construction – Machined Base:	Minimal gaps, no fillings, smooth easy to clean surface.
Specialized Laser Identification:	Permanent brand and nomenclature marking.

BEARINGS

Corrosion Resistant Engineered Solutions



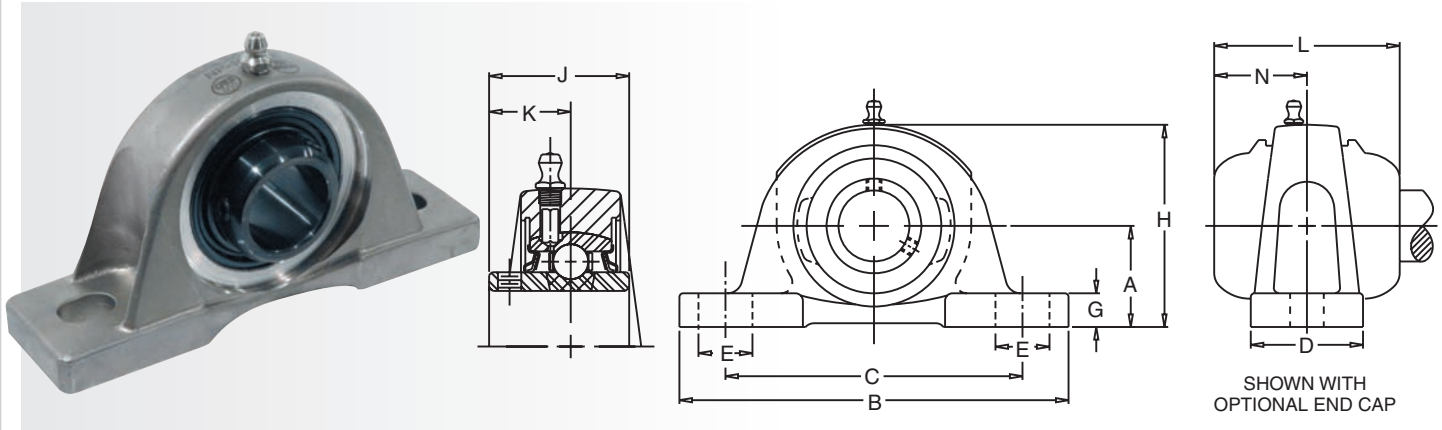

NP-C CR Series Pillow Blocks

CR Gold Description	Shaft Size	A	B	C Max.	C Min.	D	E	G	H	J	K	L	N	Bolt Size	Open Cap	Closed Cap	Backside Shield
NP-12C CR	3/4	1 5/16	5	4 1/8	3 3/8	1 1/2	3/4	1/2	2 9/16	1 7/32	23/32	3 9/32	1 41/64	3/8	ECO-12	ECC-12	N/A
NP-16C CR	1	1 7/16	5 1/2	4 1/2	3 3/4	1 1/2	3/4	1/2	2 13/16	1 3/8	13/16	3 15/32	1 47/64	3/8	ECO-16	ECC-16	N/A
NP-19C CR	1 3/16	1 11/16	6 1/2	5 1/16	4 7/16	1 7/8	13/16	9/16	3 3/8	1 1/2	7/8	3 19/32	1 51/64	1/2	ECO-19	ECC-19	N/A
NP-20RC CR	1 1/4	1 11/16	6 1/2	5 1/16	4 7/16	1 7/8	13/16	9/16	3 3/8	1 1/2	7/8	3 19/32	1 51/64	1/2	ECO-20R	ECC-19	N/A
NP-20C CR	1 1/4	1 7/8	6 9/16	5 5/16	4 11/16	1 7/8	13/16	5/8	3 3/4	1 11/16	1	3 27/32	1 59/64	1/2	ECO-20	ECC-23	N/A
NP-23C CR	1 7/16	1 7/8	6 9/16	5 5/16	4 11/16	1 7/8	13/16	5/8	3 3/4	1 11/16	1	3 27/32	1 59/64	1/2	ECO-23	ECC-23	N/A
NP-24C CR	1 1/2	1 15/16	7 1/4	5 7/8	4 7/8	2 1/8	1	11/16	3 15/16	1 15/16	1 3/16	4 7/32	2 7/64	1/2	ECO-24	ECC-24	N/A
NP-27C CR	1 11/16	2 1/8	7 1/2	6 1/16	5 7/16	2 1/8	13/16	11/16	4 1/4	1 15/16	1 3/16	4 7/32	2 1/8	1/2	ECO-27	ECC-27	N/A
NP-31C CR	1 15/16	2 1/4	8 1/8	6 1/2	6	2 3/8	7/8	3/4	4 9/16	2 1/32	1 9/32	4 13/32	2 13/64	5/8	ECO-31	ECC-31	N/A
NP-32C CR	2	2 1/2	8 5/8	7	6 1/2	2 3/8	7/8	3/4	5	2 3/16	1 5/16	4 43/64	2 21/64	5/8	ECO-32	ECC-35	N/A
NP-35C CR	2 3/16	2 1/2	8 5/8	7	6 1/2	2 3/8	7/8	3/4	5	2 3/16	1 5/16	4 43/64	2 21/64	5/8	ECO-35	ECC-35	N/A
NP-39C CR	2 7/16	2 3/4	9 1/2	7 5/8	6 7/8	2 3/4	1	7/8	5 9/16	2 9/16	1 9/16	5 11/64	2 37/64	5/8	ECO-39	ECC-39	N/A

Mounted Ball Bearings

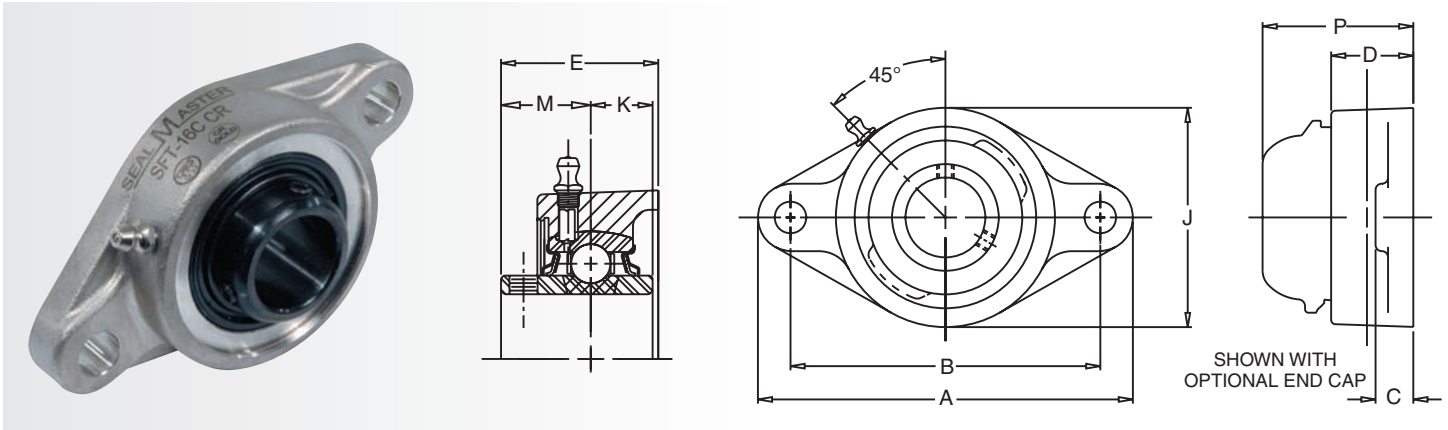

SFT-C CR Series 2 Bolt Flange

CR Gold Description	Shaft Size	A	B	C	D	E	J	K	M	P	Bolt Size	Open Cap	Closed Cap	Backside Shield
SFT-12C CR	3/4	4 13/32	3 17/32	7/16	31/32	1 9/32	2 1/2	1/2	23/32	2 13/64	3/8	ECO-12	ECC-12	2BSS-12
SFT-16C CR	1	4 7/8	3 57/64	17/32	1 5/64	1 7/16	2 3/4	9/16	13/16	2 23/64	7/16	ECO-16	ECC-16	2BSS-16
SFT-19C CR	1 3/16	5 9/16	4 19/32	17/32	1 7/32	1 9/16	3 1/4	5/8	7/8	2 31/64	7/16	ECO-19	ECC-19	2BSS-19
SFT-20RC CR	1 1/4	5 9/16	4 19/32	17/32	1 7/32	1 9/16	3 1/4	5/8	7/8	2 31/64	7/16	ECO-20R	ECC-19	2BSS-20R
SFT-20C CR	1 1/4	6 1/8	5 1/8	9/16	1 11/32	1 3/4	3 3/4	11/16	1	2 43/64	1/2	ECO-20	ECC-23	2BSS-20
SFT-23C CR	1 7/16	6 1/8	5 1/8	9/16	1 11/32	1 3/4	3 3/4	11/16	1	2 43/64	1/2	ECO-23	ECC-23	2BSS-23
SFT-24C CR	1 1/2	6 3/4	5 21/32	9/16	1 1/2	2 1/64	4 1/8	3/4	1 3/16	2 15/16	1/2	ECO-24	ECC-24	2BSS-24
SFT-27C CR	1 11/16	7 1/16	5 27/32	9/16	1 9/16	2 3/64	4 3/8	3/4	1 3/16	2 31/32	9/16	ECO-27	ECC-27	2BSS-27
SFT-31C CR	1 15/16	7 7/16	6 3/16	9/16	1 9/16	2 5/32	4 9/16	3/4	1 9/32	3 5/64	9/16	ECO-31	ECC-31	2BSS-31
SFT-32C CR	2	8 1/2	7 1/4	13/16	1 3/4	2 5/16	5 1/4	7/8	1 5/16	3 21/64	5/8	ECO-32	ECC-35	N/A
SFT-35C CR	2 3/16	8 1/2	7 1/4	13/16	1 3/4	2 5/16	5 1/4	7/8	1 5/16	3 21/64	5/8	ECO-35	ECC-35	2BSS-35

BEARINGS

Corrosion Resistant Engineered Solutions



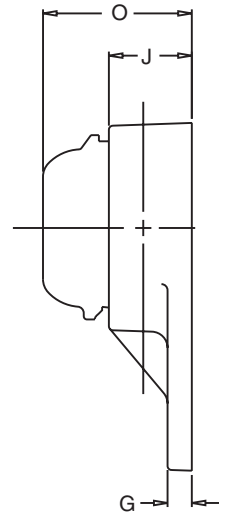
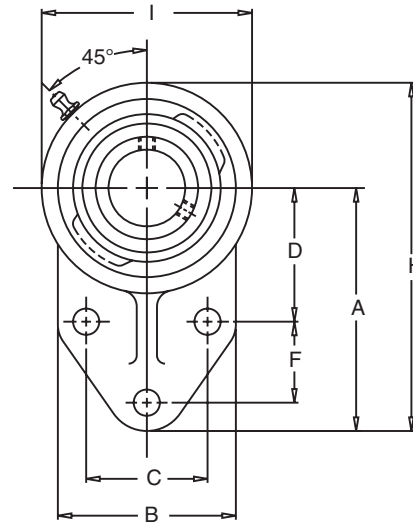
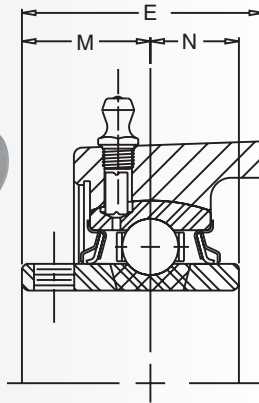

SHOWN WITH
OPTIONAL END CAP

FB-C CR Series Flange Bracket

CR Gold Description	Shaft Size	A	B	C	D	E	F	G	H	I	J	M	N	O	Bolt Size	Open Cap	Closed Cap	Backside Shield
FB-12C CR	3/4	3	2 3/8	1 1/2	1 11/16	1 11/32	7/8	5/16	4 1/4	2 1/2	1 1/32	23/32	1/2	2 17/64	3/8	ECO-12	ECC-12	N/A
FB-16C CR	1	3 3/8	2 1/2	1 5/8	1 13/16	1 1/2	1 1/8	3/8	4 3/4	2 3/4	1 9/64	13/16	9/16	2 13/32	3/8	ECO-16	ECC-16	N/A
FB-19C CR	1 3/16	3 3/4	2 3/4	1 7/8	2 1/16	1 5/8	1 1/4	3/8	5 3/8	3 1/4	1 9/32	7/8	5/8	2 35/64	3/8	ECO-19	ECC-19	N/A
FB-20RC CR	1 1/4	3 3/4	2 3/4	1 7/8	2 1/16	1 5/8	1 1/4	3/8	5 3/8	3 1/4	1 9/32	7/8	5/8	2 35/64	3/8	ECO-20R	ECC-19	N/A
FB-20C CR	1 1/4	4 1/4	3 1/4	2	2 3/8	1 7/8	1 1/4	1/2	6 1/8	3 3/4	1 15/32	1	11/16	2 51/64	1/2	ECO-20	ECC-23	N/A
FB-23C CR	1 7/16	4 1/4	3 1/4	2	2 3/8	1 7/8	1 1/4	1/2	6 1/8	3 3/4	1 15/32	1	11/16	2 51/64	1/2	ECO-23	ECC-23	N/A

Mounted Ball Bearings

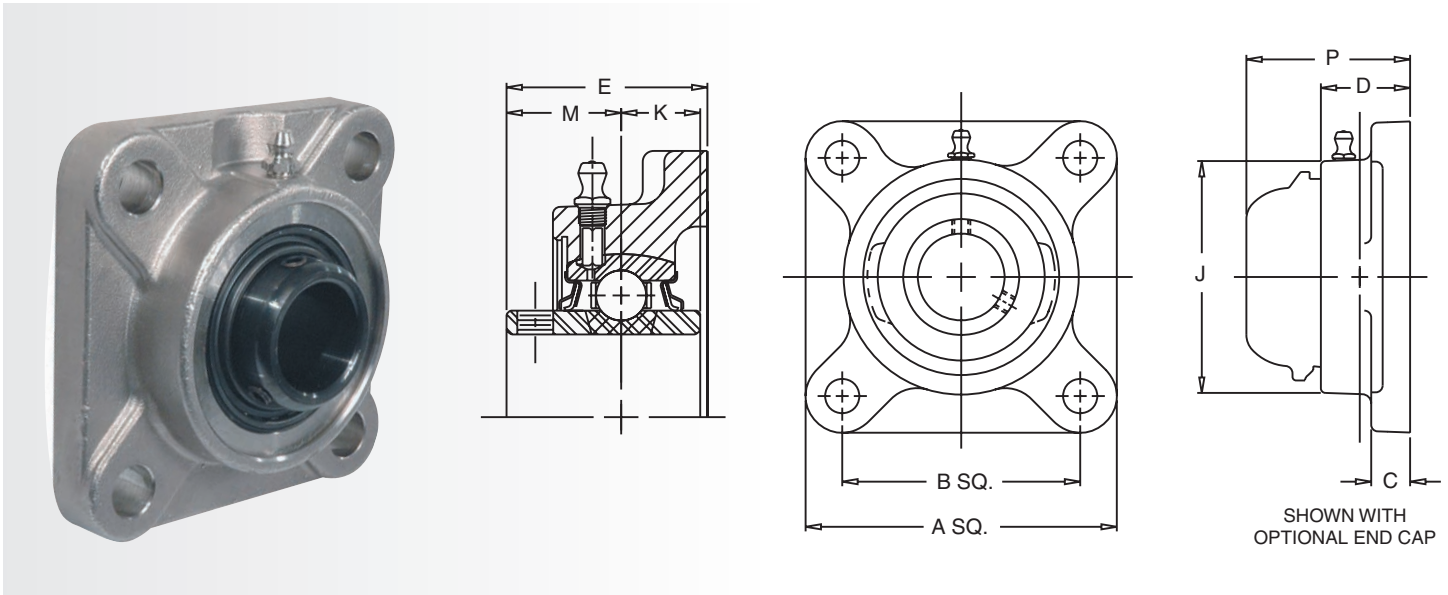

SF-C CR Series 4 Bolt Flange

CR Gold Description	Shaft Size	A	B	C	D	E	J	K	M	P	Bolt Size	Open Cap	Closed Cap	Backside Shield
SF-12C CR	3/4	3 3/8	2 1/2	7/16	31/32	1 9/32	2 1/2	1/2	23/32	2 13/64	3/8	ECO-12	ECC-12	4BSS-12
SF-16C CR	1	3 3/4	2 3/4	17/32	1 5/64	1 7/16	2 45/64	9/16	13/16	2 23/64	7/16	ECO-16	ECC-16	4BSS-16
SF-19C CR	1 3/16	4 1/4	3 1/4	17/32	1 7/32	1 9/16	3 13/64	5/8	7/8	2 31/64	7/16	ECO-19	ECC-19	4BSS-19
SF-20RC CR	1 1/4	4 1/4	3 1/4	17/32	1 7/32	1 9/16	3 13/64	5/8	7/8	2 31/64	7/16	ECO-20R	ECC-19	4BSS-20R
SF-20C CR	1 1/4	4 5/8	3 5/8	9/16	1 11/32	1 3/4	3 3/4	11/16	1	2 43/64	1/2	ECO-20	ECC-23	4BSS-20
SF-23C CR	1 7/16	4 5/8	3 5/8	9/16	1 11/32	1 3/4	3 3/4	11/16	1	2 43/64	1/2	ECO-23	ECC-23	4BSS-23
SF-24C CR	1 1/2	5 1/8	4	9/16	1 1/2	2 1/64	4 5/64	3/4	1 3/16	2 15/16	1/2	ECO-24	ECC-24	4BSS-24
SF-27C CR	1 11/16	5 3/8	4 1/8	9/16	1 9/16	2 3/64	4 21/64	3/4	1 3/16	2 31/32	9/16	ECO-27	ECC-27	4BSS-27
SF-31C CR	1 15/16	5 5/8	4 3/8	9/16	1 9/16	2 5/32	4 35/64	3/4	1 9/32	3 5/64	9/16	ECO-31	ECC-31	4BSS-31
SF-32C CR	2	6 3/8	5 1/8	13/16	1 3/4	2 5/16	5 3/16	7/8	1 5/16	3 21/64	5/8	ECO-32	ECC-35	4BSS-32
SF-35C CR	2 3/16	6 3/8	5 1/8	13/16	1 3/4	2 5/16	5 3/16	7/8	1 5/16	3 21/64	5/8	ECO-35	ECC-35	4BSS-35
SF-39C CR	2 7/16	6 7/8	5 5/8	13/16	1 15/16	2 25/32	5 7/16	1	1 9/16	3 45/64	5/8	ECO-39	ECC-39	4BSS-39

BEARINGS

Corrosion Resistant Engineered Solutions



CRES PN Gold *Mounted Ball Bearings*

PN Gold bearings feature a high phosphorus, electroless nickel coated steel insert and a patented, multiple lip high performance seal. Specially engineered for industries with corrosive wash down environments such as food and beverage, pharmaceuticals and chemical processing. The PN Gold mounted ball bearings provide outstanding performance in demanding corrosive environments.



Nomenclature:

CRPS - PN16T

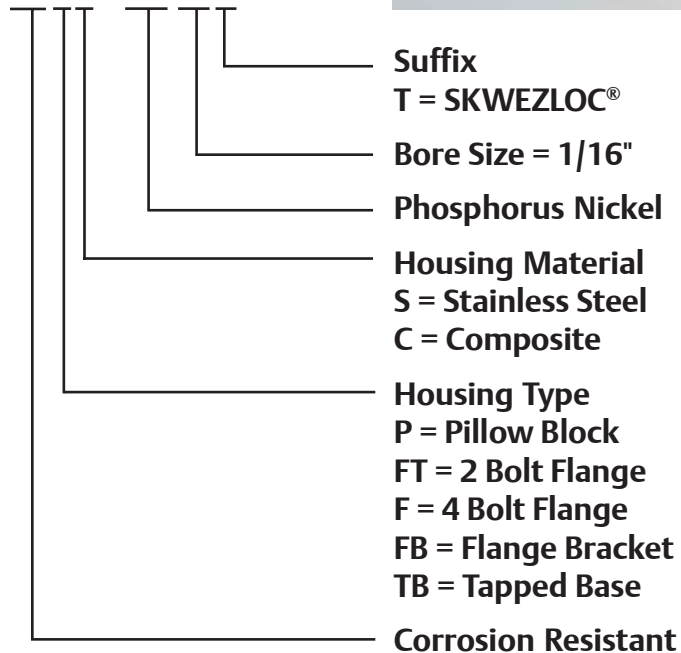

Mounted Ball Bearings

Components Material

Housing:	316 Passivated Stainless Steel or High Strength Composite
Bearing Races:	High Phosphorus Electroless Nickel Plated 52100 Steel
Balls:	440C Stainless Steel
Retainer:	Unique Metal Land Riding Retainer
Seal:	High Performance Seal (HPS)
Set Screws:	300 Stainless Steel
Grease Fitting:	303 Stainless Steel
Grease:	Sealmaster GoldPlex-FG

Features and Benefits

Insert

High Phosphorus Electroless Nickel Plating:	Provides exceptional corrosion resistance.
High Performance Seal (HPS):	Multi-directional sealing with excellent chemical resistance.
Wide Outer Race:	Provides extra grease capacity.
Zone Hardened Inner Race:	Provides longer life and quieter operation, improved locking reliability.
Unique Metal Land Riding Retainer:	Corrosion resistant, improves lubrication circulation.
Lock Pin and Dimple System:	Provides direct lubrication path and +/- 2° static misalignment and prevents outer race rotation.
H1 Food Grade Grease:	Non-toxic grease with superior corrosion resistance and excellent wash out properties.

BEARINGS

Corrosion Resistant Engineered Solutions



Features and Benefits

Stainless Steel Housing

316 Passivated Stainless Steel:

Highest amount of corrosion resistance currently available for stainless steel bearing housings.

Advanced Casting Technology:

Investment cast process yields a smooth, easy to clean surface.

Solid Construction – Machined Base:

Minimal gaps, no fillings, smooth easy to clean surface.

Specialized Laser Identification:

Permanent brand and nomenclature marking.

Composite Housing

High Strength Composite:

High load capacity.

Solid Construction – Machined Base:

Minimal gaps, no filling, smooth easy to clean surface.

Reinforced Stainless Steel Bolt Ferrules:

Increased strength around bolt holes.

Specialized Unit Identification:

Permanent brand and nomenclature marking.

Stainless Steel Housing

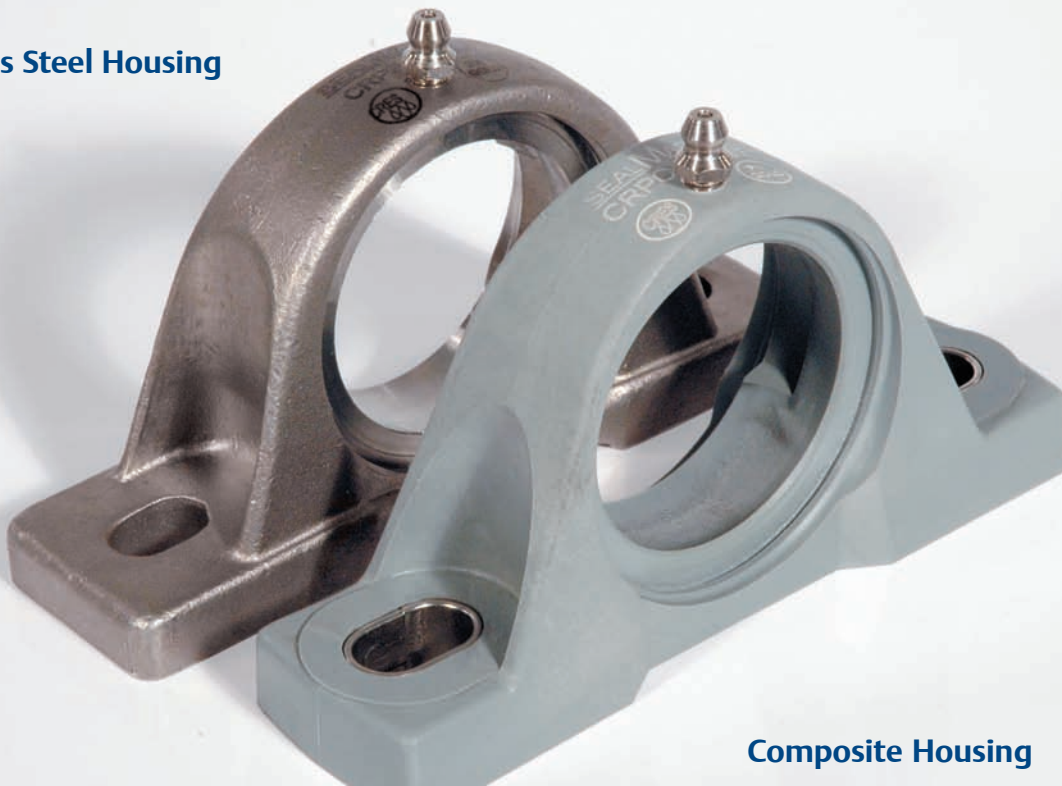

Composite Housing

Mounted Ball Bearings

Sealmaster Patented HPS Seal for Superior Protection

- Triple lip contact seal design provides multi-directional sealing to minimize contamination ingress and retain lubrication
- Highly durable, FKM seal lip material provides good chemical resistance and can withstand high temperatures
- 304 stainless steel shell protects bearing components from incoming contaminants
- 304 stainless steel rotating flinger provides a corrosion resistant wear surface for all three lips and shields seal from contamination and washdown
- Grease cavities in seal assembly are factory filled with lubricant prior to shipment for additional contaminant avoidance

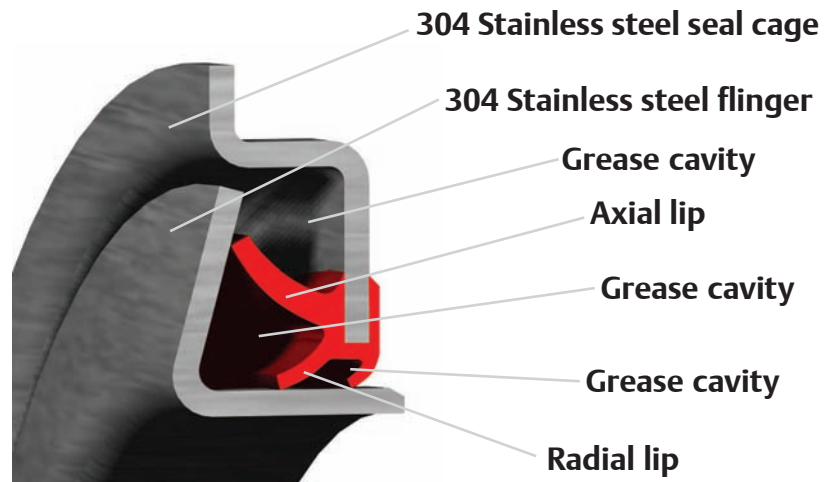

Sealmaster HPS Seal
(U.S. Patent Number 6,817,769)

BEARINGS

Corrosion Resistant Engineered Solutions



CRES

PN Gold with SKWEZLOC *Shaft Locking Mechanism*

The key to overall locking performance. The patented SKWEZLOC locking collar puts it a world apart from ordinary shaft locking devices. Six equally-spaced centering surfaces (inner race fingers or extension tabs) grip the shaft and hold it tight, locating it in near-perfect concentricity with the race. Fretting corrosion is reduced. Balancing of the assembly is easier and locking reliability is maintained.

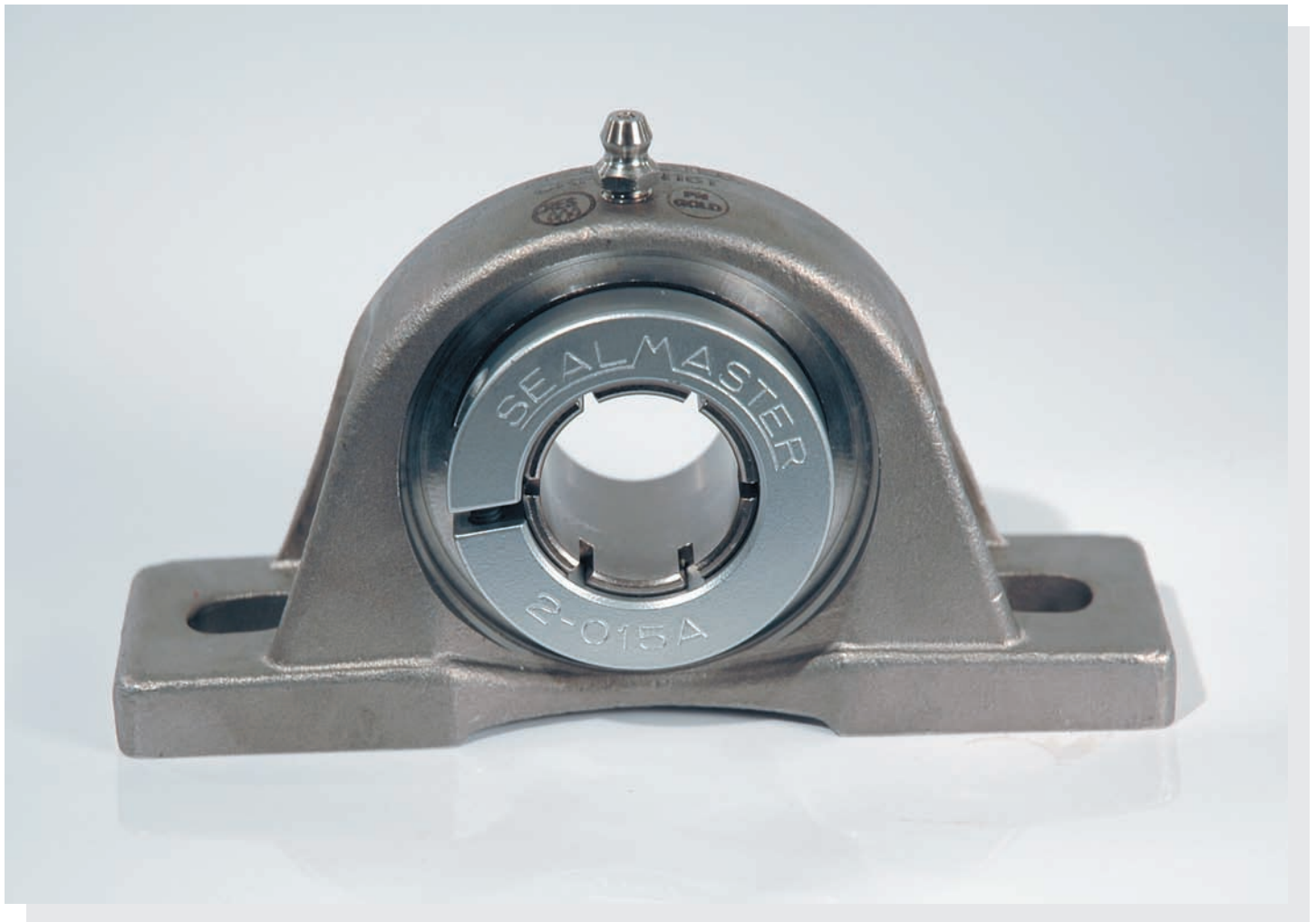

Mounted Ball Bearings

SKWEZLOC Locking Collar Centers the Shaft in the Bearing Bore... Secures the Shaft with Near-Perfect Concentricity

- Quieter smoother operation at higher speeds
- Quickly, easily installed, removed and/or repositioned
- Shaft protected from scoring or burring
- Reduced out-of-balance vibrational forces and fretting corrosion



“Putting the Collar” on Vibration...

The design of the unique SKWEZLOC collar and the near-perfect shaft centering greatly reduces out-of-balance vibrational forces that tend to shorten bearing life. Fretting corrosion is also minimized.

“Rings True” – Every Time...

Because the SKWEZLOC collar centers the shaft concentricity in the bore of the bearing, the shaft runs truer and you save on bearing maintenance and replacement costs. Because there is no set screw, shaft marring is avoided. Ballpath roundness is maintained.

BEARINGS

Corrosion Resistant Engineered Solutions





CRPS-PN, CRPS-PN T Series Pillow Blocks / Stainless Steel Housings

Set Screw Description	SKWEZLOC Description	Shaft Size	A	B	C Max.	C Min.	D	E	G
CRPS-PN12	CRPS-PN12T	3/4	1 5/16	5	4 1/8	3 3/8	1 1/2	3/4	1/2
CRPS-PN16	CRPS-PN16T	1	1 7/16	5 1/2	4 1/2	3 3/4	1 1/2	3/4	1/2
CRPS-PN19	CRPS-PN19T	1 3/16	1 11/16	6 1/2	5 1/16	4 7/16	1 7/8	13/16	9/16
CRPS-PN20R	CRPS-PN20RT	1 1/4	1 11/16	6 1/2	5 1/16	4 7/16	1 7/8	13/16	9/16
CRPS-PN20	CRPS-PN20T	1 1/4	1 7/8	6 9/16	5 5/16	4 11/16	1 7/8	13/16	5/8
CRPS-PN23	CRPS-PN23T	1 7/16	1 7/8	6 9/16	5 5/16	4 11/16	1 7/8	13/16	5/8
CRPS-PN24	CRPS-PN24T	1 1/2	1 15/16	7 1/4	5 7/8	4 7/8	2 1/8	1	11/16
CRPS-PN27	CRPS-PN27T	1 11/16	2 1/8	7 1/2	6 1/16	5 7/16	2 1/8	13/16	11/16
CRPS-PN31	CRPS-PN31T	1 15/16	2 1/4	8 1/8	6 1/2	6	2 3/8	7/8	3/4
CRPS-PN32	CRPS-PN32T	2	2 1/2	8 5/8	7	6 1/2	2 3/8	7/8	3/4
CRPS-PN35	CRPS-PN35T	2 3/16	2 1/2	8 5/8	7	6 1/2	2 3/8	7/8	3/4
CRPS-PN39	CRPS-PN39T	2 7/16	2 3/4	9 1/2	7 5/8	6 7/8	2 3/4	1	7/8

Mounted Ball Bearings

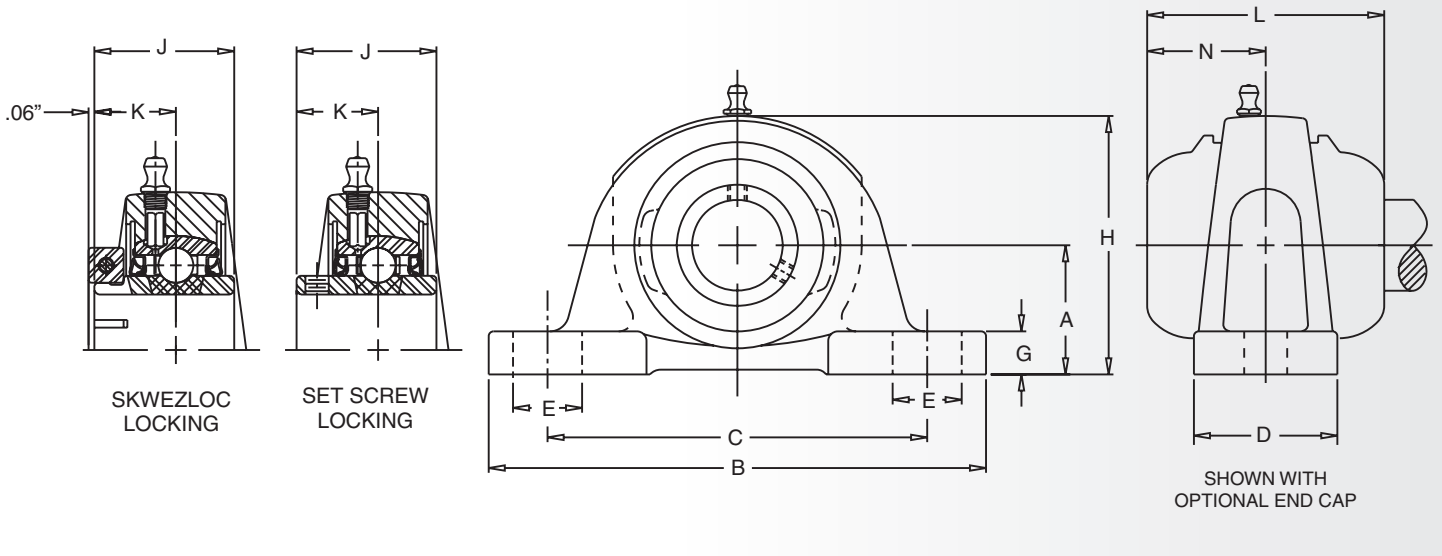

CRPS-PN, CRPS-PN T Series Pillow Blocks / Stainless Steel Housings

H	J	K	L	N	Bolt Size	Open Cap	Closed Cap	Backside Shield	Set Screw Description	SKWEZLOC Description
2 9/16	1 7/32	23/32	3 9/32	1 41/64	3/8	ECO-12	ECC-12	N/A	CRPS-PN12	CRPS-PN12T
2 13/16	1 3/8	13/16	3 15/32	1 47/64	3/8	ECO-16	ECC-16	N/A	CRPS-PN16	CRPS-PN16T
3 3/8	1 1/2	7/8	3 19/32	1 51/64	1/2	ECO-19	ECC-19	N/A	CRPS-PN19	CRPS-PN19T
3 3/8	1 1/2	7/8	3 19/32	1 51/64	1/2	ECO-20R	ECC-19	N/A	CRPS-PN20R	CRPS-PN20RT
3 3/4	1 11/16	1	3 27/32	1 59/64	1/2	ECO-20	ECC-23	N/A	CRPS-PN20	CRPS-PN20T
3 3/4	1 11/16	1	3 27/32	1 59/64	1/2	ECO-23	ECC-23	N/A	CRPS-PN23	CRPS-PN23T
3 15/16	1 15/16	1 3/16	4 7/32	2 7/64	1/2	ECO-24	ECC-24	N/A	CRPS-PN24	CRPS-PN24T
4 1/4	1 15/16	1 3/16	4 7/32	2 1/8	1/2	ECO-27	ECC-27	N/A	CRPS-PN27	CRPS-PN27T
4 9/16	2 1/32	1 9/32	4 13/32	2 13/64	5/8	ECO-31	ECC-31	N/A	CRPS-PN31	CRPS-PN31T
5	2 3/16	1 5/16	4 43/64	2 21/64	5/8	ECO-32	ECC-35	N/A	CRPS-PN32	CRPS-PN32T
5	2 3/16	1 5/16	4 43/64	2 21/64	5/8	ECO-35	ECC-35	N/A	CRPS-PN35	CRPS-PN35T
5 9/16	2 9/16	1 9/16	5 11/64	2 37/64	5/8	ECO-39	ECC-39	N/A	CRPS-PN39	CRPS-PN39T

BEARINGS

Corrosion Resistant Engineered Solutions





CRFTS-PN, CRFTS-PN T Series 2 Bolt Flange / Stainless Steel Housings

Set Screw Description	SKWEZLOC Description	Shaft Size	A	B	C	D	E	J
CRFTS-PN12	CRFTS-PN12T	3/4	4 13/32	3 17/32	7/16	31/32	1 9/32	2 1/2
CRFTS-PN16	CRFTS-PN16T	1	4 7/8	3 57/64	17/32	1 5/64	1 7/16	2 3/4
CRFTS-PN19	CRFTS-PN19T	1 3/16	5 9/16	4 19/32	17/32	1 7/32	1 9/16	3 1/4
CRFTS-PN20R	CRFTS-PN20RT	1 1/4	5 9/16	4 19/32	17/32	1 7/32	1 9/16	3 1/4
CRFTS-PN20	CRFTS-PN20T	1 1/4	6 1/8	5 1/8	9/16	1 11/32	1 3/4	3 3/4
CRFTS-PN23	CRFTS-PN23T	1 7/16	6 1/8	5 1/8	9/16	1 11/32	1 3/4	3 3/4
CRFTS-PN24	CRFTS-PN24T	1 1/2	6 3/4	5 21/32	9/16	1 1/2	2 1/64	4 1/8
CRFTS-PN27	CRFTS-PN27T	1 11/16	7 1/16	5 27/32	9/16	1 9/16	2 3/64	4 3/8
CRFTS-PN31	CRFTS-PN31T	1 15/16	7 7/16	6 3/16	9/16	1 9/16	2 5/32	4 9/16
CRFTS-PN32	CRFTS-PN32T	2	8 1/2	7 1/4	13/16	1 3/4	2 5/16	5 1/4
CRFTS-PN35	CRFTS-PN35T	2 3/16	8 1/2	7 1/4	13/16	1 3/4	2 5/16	5 1/4

Mounted Ball Bearings

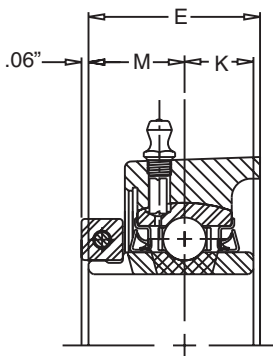

SKWEZLOC
LOCKING

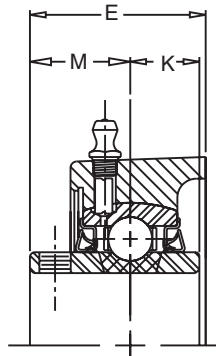

SET SCREW
LOCKING

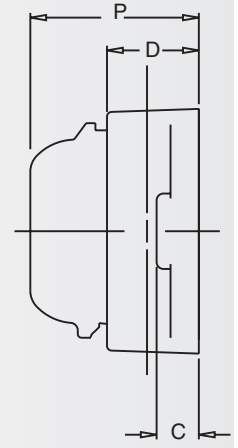
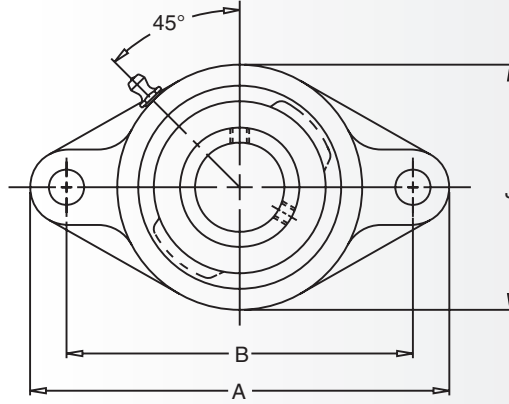

SHOWN WITH
OPTIONAL END CAP

CRFTS-PN, CRFTS-PN T Series 2 Bolt Flange / Stainless Steel Housing

K	M	P	Bolt Size	Open End Cap	Closed Cap	Backside Shield	Set Screw Description	SKWEZLOC Description
1/2	23/32	2 13/64	3/8	ECO-12	ECC-12	2BSS-12	CRFTS-PN12	CRFTS-PN12T
9/16	13/16	2 23/64	7/16	ECO-16	ECC-16	2BSS-16	CRFTS-PN16	CRFTS-PN16T
5/8	7/8	2 31/64	7/16	ECO-19	ECC-19	2BSS-19	CRFTS-PN19	CRFTS-PN19T
5/8	7/8	2 31/64	7/16	ECO-20R	ECC-19	2BSS-20R	CRFTS-PN20R	CRFTS-PN20RT
11/16	1	2 43/64	1/2	ECO-20	ECC-23	2BSS-20	CRFTS-PN20	CRFTS-PN20T
11/16	1	2 43/64	1/2	ECO-23	ECC-23	2BSS-23	CRFTS-PN23	CRFTS-PN23T
3/4	1 3/16	2 15/16	1/2	ECO-24	ECC-24	2BSS-24	CRFTS-PN24	CRFTS-PN24T
3/4	1 3/16	2 31/32	9/16	ECO-27	ECC-27	2BSS-27	CRFTS-PN27	CRFTS-PN27T
3/4	1 9/32	3 5/64	9/16	ECO-31	ECC-31	2BSS-31	CRFTS-PN31	CRFTS-PN31T
7/8	1 5/16	3 21/64	5/8	ECO-32	ECC-35	N/A	CRFTS-PN32	CRFTS-PN32T
7/8	1 5/16	3 21/64	5/8	ECO-35	ECC-35	2BSS-35	CRFTS-PN35	CRFTS-PN35T

BEARINGS

Corrosion Resistant Engineered Solutions



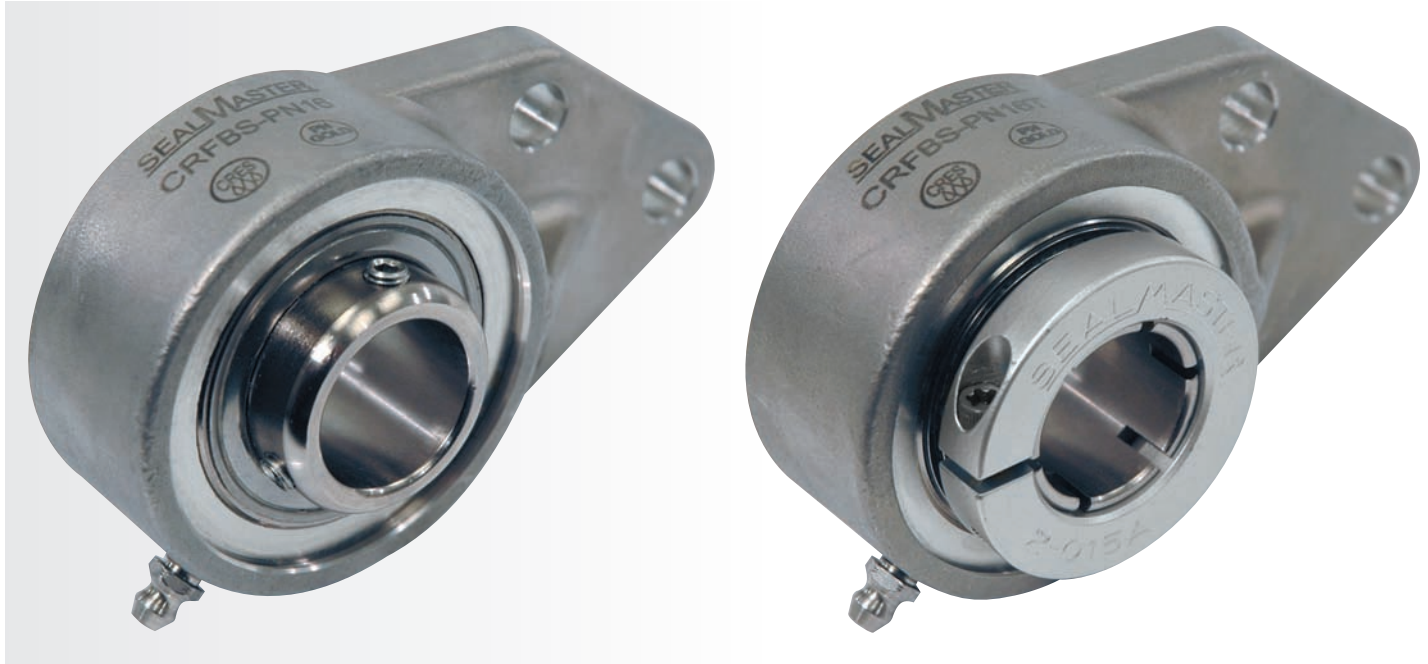

CRFBS-PN, CRFBS-PN T Series Flange Bracket / Stainless Steel Housings

Set Screw Description	SKWEZLOC Description	Shaft Size	A	B	C	D	E	F	G	H
CRFBS-PN12	CRFBS-PN12T	3/4	3	2 3/8	1 1/2	1 11/16	1 11/32	7/8	5/16	4 1/4
CRFBS-PN16	CRFBS-PN16T	1	3 3/8	2 1/2	1 5/8	1 13/16	1 1/2	1 1/8	3/8	4 3/4
CRFBS-PN19	CRFBS-PN19T	1 3/16	3 3/4	2 3/4	1 7/8	2 1/16	1 5/8	1 1/4	3/8	5 3/8
CRFBS-PN20R	CRFBS-PN20RT	1 1/4	3 3/4	2 3/4	1 7/8	2 1/16	1 5/8	1 1/4	3/8	5 3/8
CRFBS-PN20	CRFBS-PN20T	1 1/4	4 1/4	3 1/4	2	2 3/8	1 7/8	1 1/4	1/2	6 1/8
CRFBS-PN23	CRFBS-PN23T	1 7/16	4 1/4	3 1/4	2	2 3/8	1 7/8	1 1/4	1/2	6 1/8

Mounted Ball Bearings

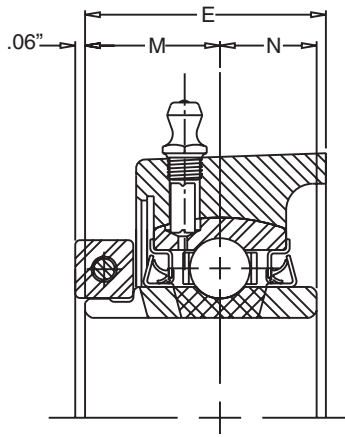

SKWEZLOC
LOCKING

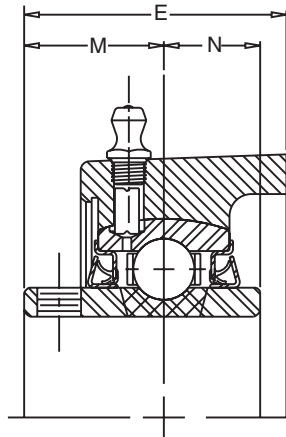

SET SCREW
LOCKING

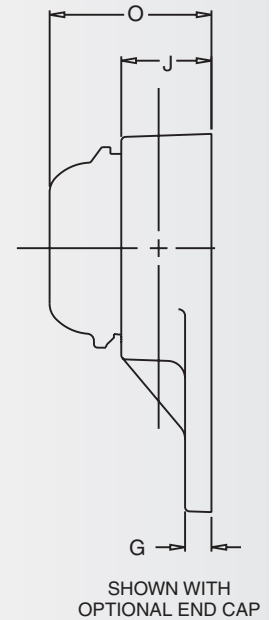
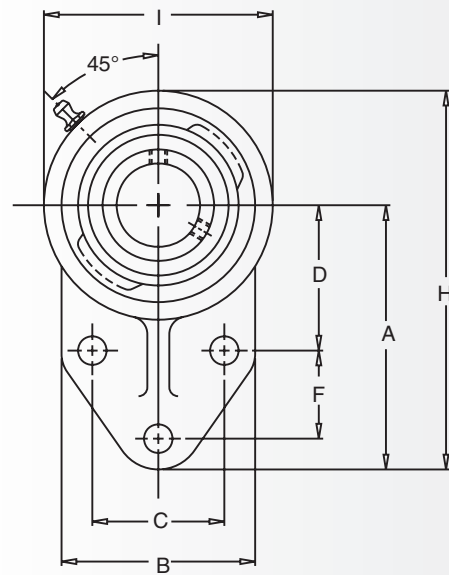

CRFBS-PN, CRFBS-PN T Series Flange Bracket / Stainless Steel Housings

I	J	M	N	O	Bolt Size	Open Cap	Closed Cap	Backside Shield	Set Screw Description	SKWEZLOC Description
2 1/2	1 1/32	23/32	1/2	2 17/64	3/8	ECO-12	ECC-12	N/A	CRFBS-PN12	CRFBS-PN12T
2 3/4	1 9/64	13/16	9/16	2 13/32	3/8	ECO-16	ECC-16	N/A	CRFBS-PN16	CRFBS-PN16T
3 1/4	1 9/32	7/8	5/8	2 35/64	3/8	ECO-19	ECC-19	N/A	CRFBS-PN19	CRFBS-PN19T
3 1/4	1 9/32	7/8	5/8	2 35/64	3/8	ECO-20R	ECC-19	N/A	CRFBS-PN20R	CRFBS-PN20RT
3 3/4	1 15/32	1	11/16	2 51/64	1/2	ECO-20	ECC-23	N/A	CRFBS-PN20	CRFBS-PN20T
3 3/4	1 15/32	1	11/16	2 51/64	1/2	ECO-23	ECC-23	N/A	CRFBS-PN23	CRFBS-PN23T

BEARINGS

Corrosion Resistant Engineered Solutions



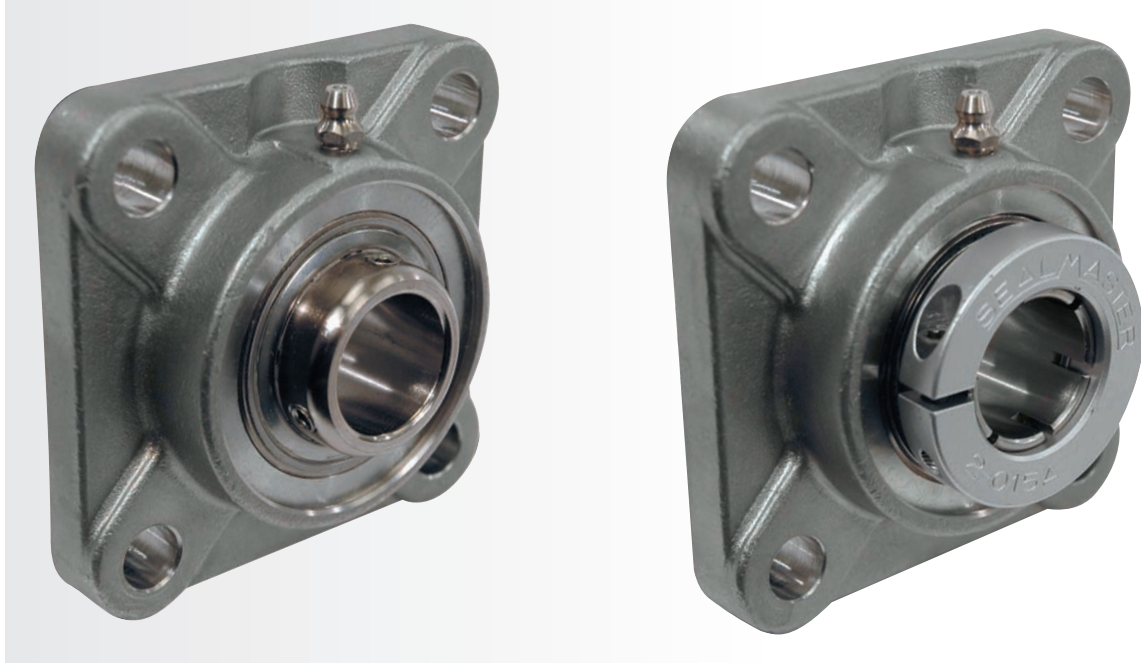

CRFS-PN, CRFS-PN T Series 4 Bolt Flange Bracket / Stainless Steel Housings

Set Screw Description	SKWEZLOC Description	Shaft Size	A	B	C	D	E	J
CRFS-PN12	CRFS-PN12T	3/4	3 3/8	2 1/2	7/16	31/32	1 9/32	2 1/2
CRFS-PN16	CRFS-PN16T	1	3 3/4	2 3/4	17/32	1 5/64	1 7/16	2 45/64
CRFS-PN19	CRFS-PN19T	1 3/16	4 1/4	3 1/4	17/32	1 7/32	1 9/16	3 13/64
CRFS-PN20R	CRFS-PN20RT	1 1/4	4 1/4	3 1/4	17/32	1 7/32	1 9/16	3 13/64
CRFS-PN20	CRFS-PN20T	1 1/4	4 5/8	3 5/8	9/16	1 11/32	1 3/4	3 3/4
CRFS-PN23	CRFS-PN23T	1 7/16	4 5/8	3 5/8	9/16	1 11/32	1 3/4	3 3/4
CRFS-PN24	CRFS-PN24T	1 1/2	5 1/8	4	9/16	1 1/2	2 1/64	4 5/64
CRFS-PN27	CRFS-PN27T	1 11/16	5 3/8	4 1/8	9/16	1 9/16	2 3/64	4 21/64
CRFS-PN31	CRFS-PN31T	1 15/16	5 5/8	4 3/8	9/16	1 9/16	2 5/32	4 35/64
CRFS-PN32	CRFS-PN32T	2	6 3/8	5 1/8	13/16	1 3/4	2 5/16	5 3/16
CRFS-PN35	CRFS-PN35T	2 3/16	6 3/8	5 1/8	13/16	1 3/4	2 5/16	5 3/16
CRFS-PN39	CRFS-PN39T	2 7/16	6 7/8	5 5/8	13/16	1 15/16	2 25/32	5 7/16

Mounted Ball Bearings

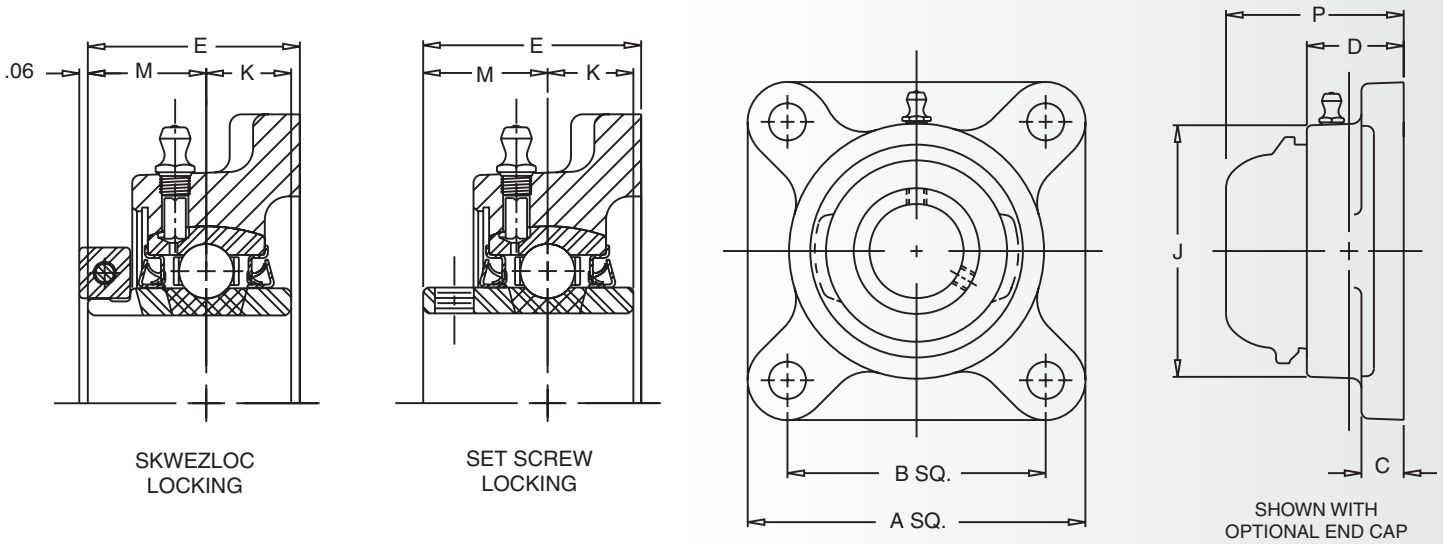

CRFS-PN, CRFS-PN T Series 4 Bolt Flange Bracket / Stainless Steel Housings

K	M	P	Bolt Size	Open Cap	Closed Cap	Backside Shield	Set Screw Description	SKWEZLOC Description
1/2	23/32	2 13/64	3/8	ECO-12	ECC-12	4BSS-12	CRFS-PN12	CRFS-PN12T
9/16	13/16	2 23/64	7/16	ECO-16	ECC-16	4BSS-16	CRFS-PN16	CRFS-PN16T
5/8	7/8	2 31/64	7/16	ECO-19	ECC-19	4BSS-19	CRFS-PN19	CRFS-PN19T
5/8	7/8	2 31/64	7/16	ECO-20R	ECC-19	4BSS-20R	CRFS-PN20R	CRFS-PN20RT
11/16	1	2 43/64	1/2	ECO-20	ECC-23	4BSS-20	CRFS-PN20	CRFS-PN20T
11/16	1	2 43/64	1/2	ECO-23	ECC-23	4BSS-23	CRFS-PN23	CRFS-PN23T
3/4	1 3/16	2 15/16	1/2	ECO-24	ECC-24	4BSS-24	CRFS-PN24	CRFS-PN24T
3/4	1 3/16	2 31/32	9/16	ECO-27	ECC-27	4BSS-27	CRFS-PN27	CRFS-PN27T
3/4	1 9/32	3 5/64	9/16	ECO-31	ECC-31	4BSS-31	CRFS-PN31	CRFS-PN31T
7/8	1 5/16	3 21/64	5/8	ECO-32	ECC-35	4BSS-32	CRFS-PN32	CRFS-PN32T
7/8	1 5/16	3 21/64	5/8	ECO-35	ECC-35	4BSS-35	CRFS-PN35	CRFS-PN35T
1	1 9/16	3 45/64	5/8	ECO-39	ECC-39	4BSS-39	CRFS-PN39	CRFS-PN39T

BEARINGS

Corrosion Resistant Engineered Solutions



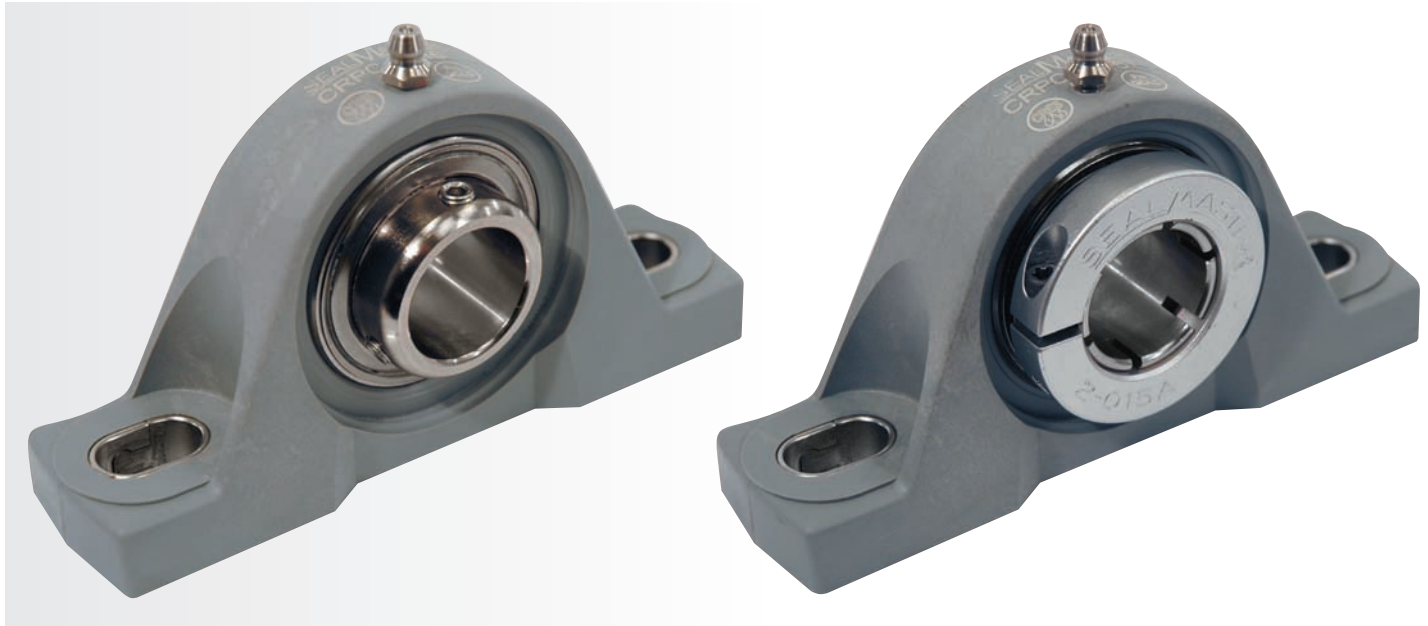

CRPC-PN, CRPC-PN T Series Pillow Blocks / Composite Housings

Set Screw Description	SKWEZLOC Description	Shaft Size	A	B	C MAX.	C MIN.	D	E	G	H
CRPC-PN12	CRPC-PN12T	3/4	1 5/16	5	4 1/8	3 3/8	1 1/2	3/4	9/16	2 35/64
CRPC-PN16	CRPC-PN16T	1	1 7/16	5 1/2	4 1/2	3 3/4	1 1/2	3/4	9/16	2 13/16
CRPC-PN19	CRPC-PN19T	1 3/16	1 11/16	6 1/2	5 1/16	4 7/16	1 7/8	13/16	11/16	3 21/64
CRPC-PN20R	CRPC-PN20RT	1 1/4	1 11/16	6 1/2	5 1/16	4 7/16	1 7/8	13/16	11/16	3 21/64
CRPC-PN20	CRPC-PN20T	1 1/4	1 7/8	6 9/16	5 5/16	4 11/16	1 7/8	13/16	11/16	3 3/4
CRPC-PN23	CRPC-PN23T	1 7/16	1 7/8	6 9/16	5 5/16	4 11/16	1 7/8	13/16	11/16	3 3/4
CRPC-PN24	CRPC-PN24T	1 1/2	1 15/16	7 1/4	5 11/16	5 1/16	2 1/8	13/16	11/16	4 1/64

Mounted Ball Bearings

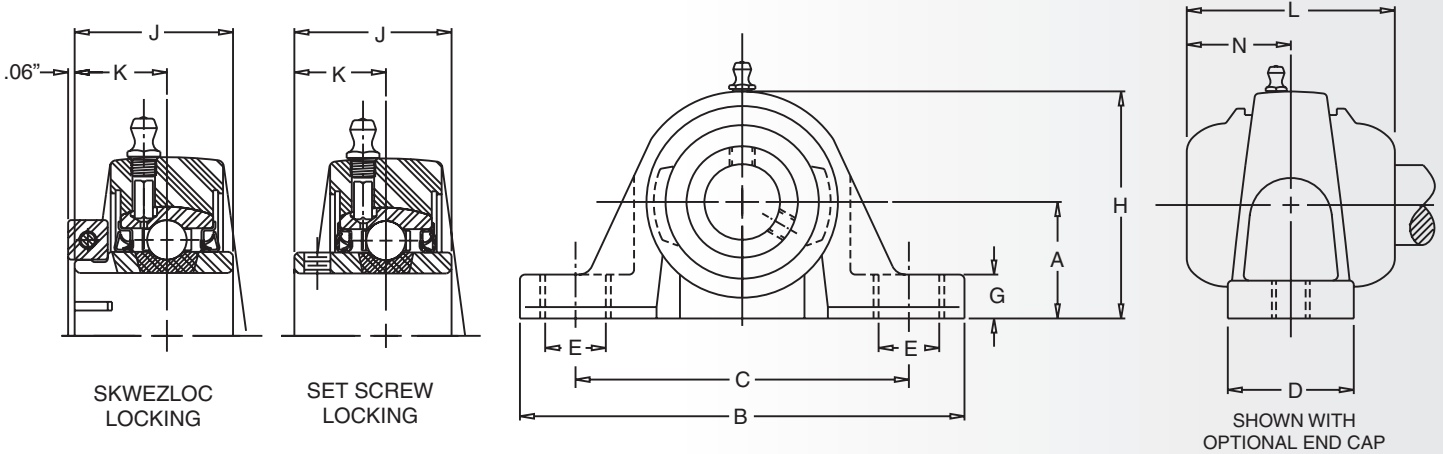

CRPC-PN, CRPC-PN T Series Pillow Blocks / Composite Housings

J	K	L	N	Bolt Size	Open Cap	Closed Cap	Backside Shield	Set Screw Description	SKWEZLOC Description
1 7/32	23/32	3 9/32	1 41/64	3/8	ECO-12	ECC-12	N/A	CRPC-PN12	CRPC-PN12T
1 3/8	13/16	3 15/32	1 47/64	3/8	ECO-16	ECC-16	N/A	CRPC-PN16	CRPC-PN16T
1 1/2	7/8	3 19/32	1 51/64	1/2	ECO-19	ECC-19	N/A	CRPC-PN19	CRPC-PN19T
1 1/2	7/8	3 19/32	1 51/64	1/2	ECO-20R	ECC-19	N/A	CRPC-PN20R	CRPC-PN20RT
1 11/16	1	3 27/32	1 59/64	1/2	ECO-20	ECC-23	N/A	CRPC-PN20	CRPC-PN20T
1 11/16	1	3 27/32	1 59/64	1/2	ECO-23	ECC-23	N/A	CRPC-PN23	CRPC-PN23T
1 15/16	1 3/16	4 7/32	2 7/64	1/2	ECO-24	ECC-24	N/A	CRPC-PN24	CRPC-PN24T

BEARINGS

Corrosion Resistant Engineered Solutions





CRFTC-PN, CRFTC-PN T Series 2 Bolt Flange / Composite Housings

Set Screw Description	SKWEZLOC Description	Shaft Size	A	B	C	D	E	J
CRFTC-PN12	CRFTC-PN12T	3/4	4 15/32	3 17/32	7/16	31/32	1 9/32	2 7/16
CRFTC-PN16	CRFTC-PN16T	1	4 15/16	3 57/64	17/32	1 5/64	1 7/16	2 23/32
CRFTC-PN19	CRFTC-PN19T	1 3/16	5 11/16	4 19/32	17/32	1 7/32	1 9/16	3 1/4
CRFTC-PN20R	CRFTC-PN20RT	1 1/4	5 11/16	4 19/32	17/32	1 7/32	1 9/16	3 1/4
CRFTC-PN20	CRFTC-PN20T	1 1/4	6 21/64	5 1/8	9/16	1 11/32	1 3/4	3 45/64
CRFTC-PN23	CRFTC-PN23T	1 7/16	6 21/64	5 1/8	9/16	1 11/32	1 3/4	3 45/64
CRFTC-PN24	CRFTC-PN24T	1 1/2	6 29/32	5 21/32	9/16	1 1/2	2 1/64	4 7/64

Mounted Ball Bearings

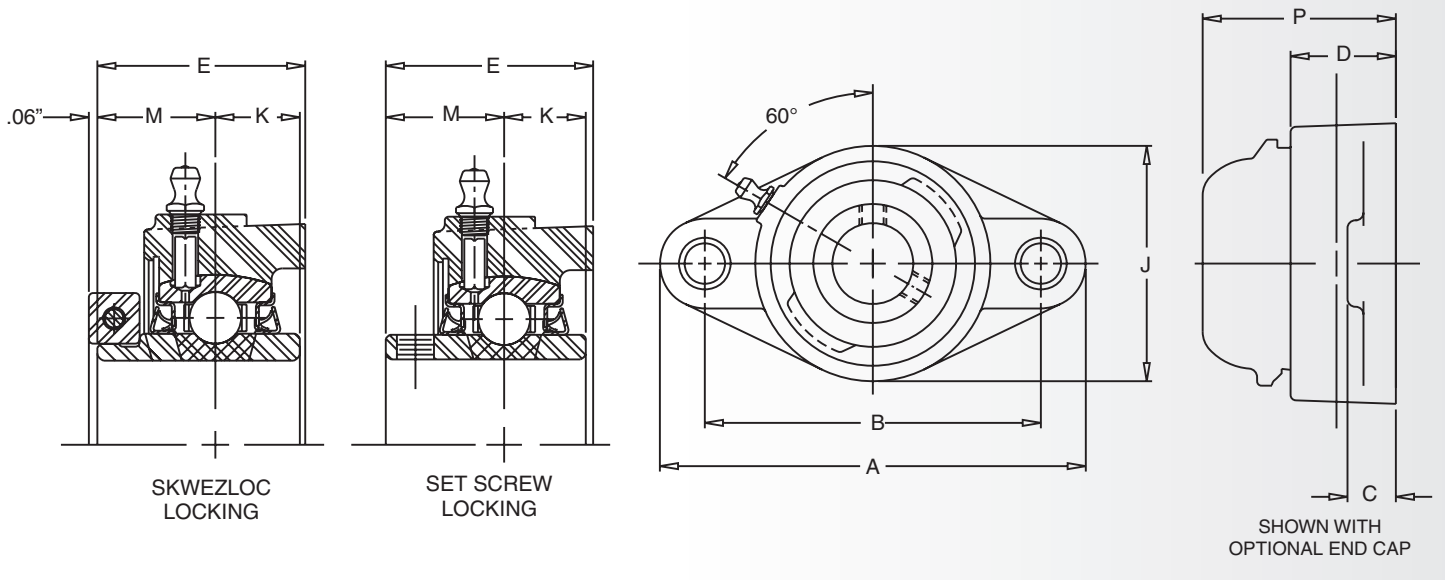

CRFTC-PN, CRFTC-PN T Series 2 Bolt Flange / Composite Housings

K	M	P	Bolt Size	Open Cap	Closed Cap	Backside Shield	Setscrew Description	SKWEZLOC Description
1/2	23/32	2 13/64	3/8	ECO-12	ECC-12	2BSS-12	CRFTC-PN12	CRFTC-PN12T
9/16	13/16	2 23/64	7/16	ECO-16	ECC-16	2BSS-16	CRFTC-PN16	CRFTC-PN16T
5/8	7/8	2 31/64	7/16	ECO-19	ECC-19	2BSS-19	CRFTC-PN19	CRFTC-PN19T
5/8	7/8	2 31/64	7/16	ECO-20R	ECC-19	2BSS-20R	CRFTC-PN20R	CRFTC-PN20RT
11/16	1	2 43/64	1/2	ECO-20	ECC-23	2BSS-20	CRFTC-PN20	CRFTC-PN20T
11/16	1	2 43/64	1/2	ECO-23	ECC-23	2BSS-23	CRFTC-PN23	CRFTC-PN23T
3/4	1 3/16	2 15/16	1/2	ECO-24	ECC-24	2BSS-24	CRFTC-PN24	CRFTC-PN24T

BEARINGS

Corrosion Resistant Engineered Solutions



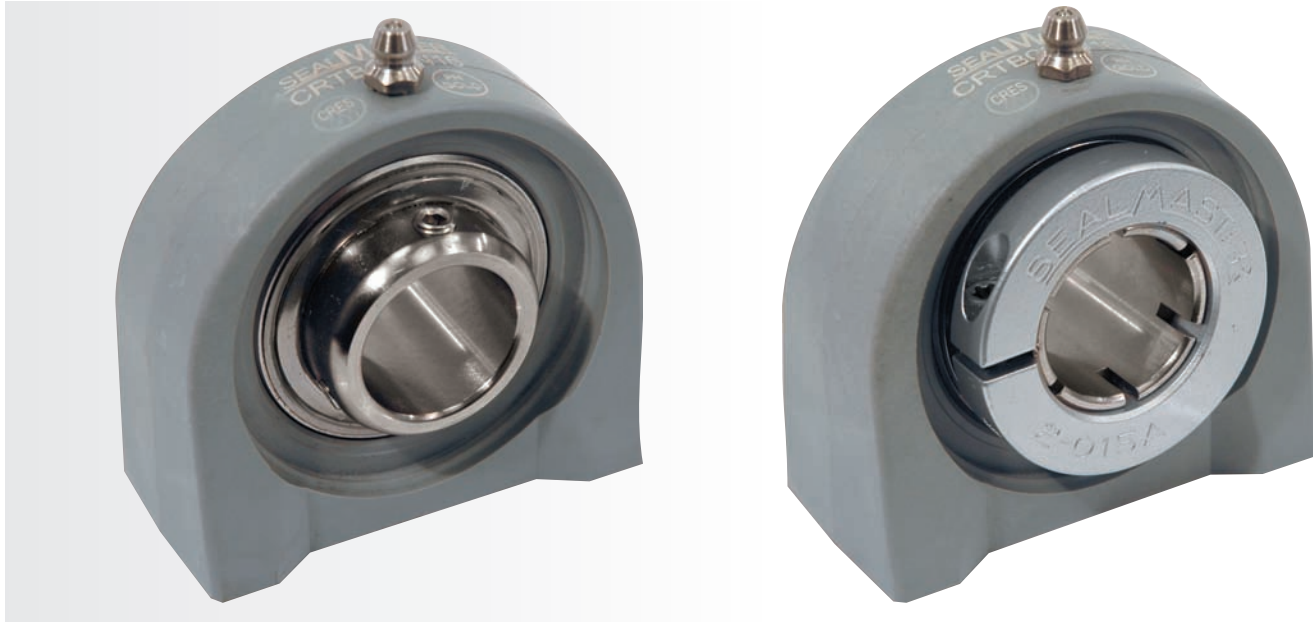

CRTBC-PN, CRTBC-PN T Series Tapped Base / Composite Housings

Set Screw Description	SKWEZLOC Description	Shaft Size	A	B	C	D	H	J	K
CRTBC-PN12	CRTBC-PN12T	3/4	1 5/16	3 1/8	2	1 1/2	2 9/16	1 7/32	23/32
CRTBC-PN16	CRTBC-PN16T	1	1 7/16	3	2	1 1/2	2 13/16	1 3/8	13/16
CRTBC-PN19	CRTBC-PN19T	1 3/16	1 11/16	4	3	1 1/2	3 3/8	1 1/2	7/8
CRTBC-PN20R	CRTBC-PN20RT	1 1/4	1 11/16	4	3	1 1/2	3 3/8	1 1/2	7/8
CRTBC-PN20	CRTBC-PN20T	1 1/4	1 7/8	4 1/4	3 1/4	1 7/8	3 3/4	1 11/16	1
CRTBC-PN23	CRTBC-PN23T	1 7/16	1 7/8	4 1/4	3 1/4	1 7/8	3 3/4	1 11/16	1
CRTBC-PN24	CRTBC-PN24T	1 1/2	1 15/16	4 5/8	3 1/2	1 7/8	3 15/16	1 15/16	1 3/16

Mounted Ball Bearings

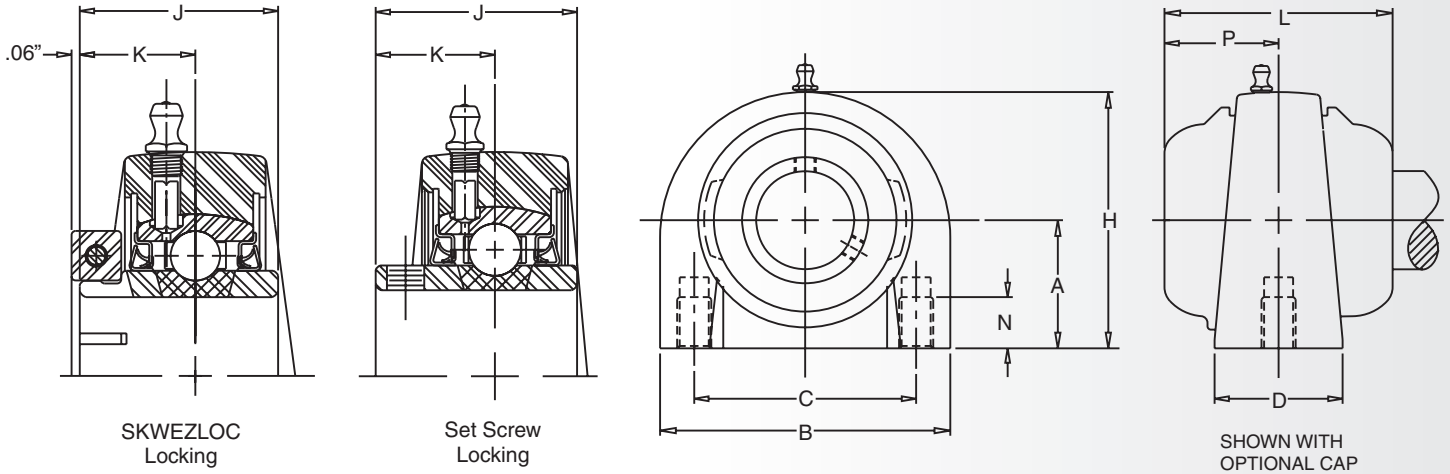

CRTBC-PN, CRTBC-PN T Series Tapped Base / Composite Housings

L	N	P	Bolt Size	Open Cap	Closed Cap	Backside Shield	Set Screw Description	SKWEZLOC Description
3 9/32	1/2	1 41/64	3/8-16	ECO-12	ECC-12	N/A	CRTBC-PN12	CRTBC-PN12T
3 15/32	1/2	1 47/64	3/8-16	ECO-16	ECC-16	N/A	CRTBC-PN16	CRTBC-PN16T
3 19/32	5/8	1 51/64	7/16-14	ECO-19	ECC-19	N/A	CRTBC-PN19	CRTBC-PN19T
3 19/32	5/8	1 51/64	7/16-14	ECO-20R	ECC-19	N/A	CRTBC-PN20R	CRTBC-PN20RT
3 27/32	3/4	1 59/64	1/2-13	ECO-20	ECC-23	N/A	CRTBC-PN20	CRTBC-PN20T
3 27/32	3/4	1 59/64	1/2-13	ECO-23	ECC-23	N/A	CRTBC-PN23	CRTBC-PN23T
4 7/32	3/4	2 7/64	1/2-13	ECO-24	ECC-24	N/A	CRTBC-PN24	CRTBC-PN24T

BEARINGS

Corrosion Resistant Engineered Solutions



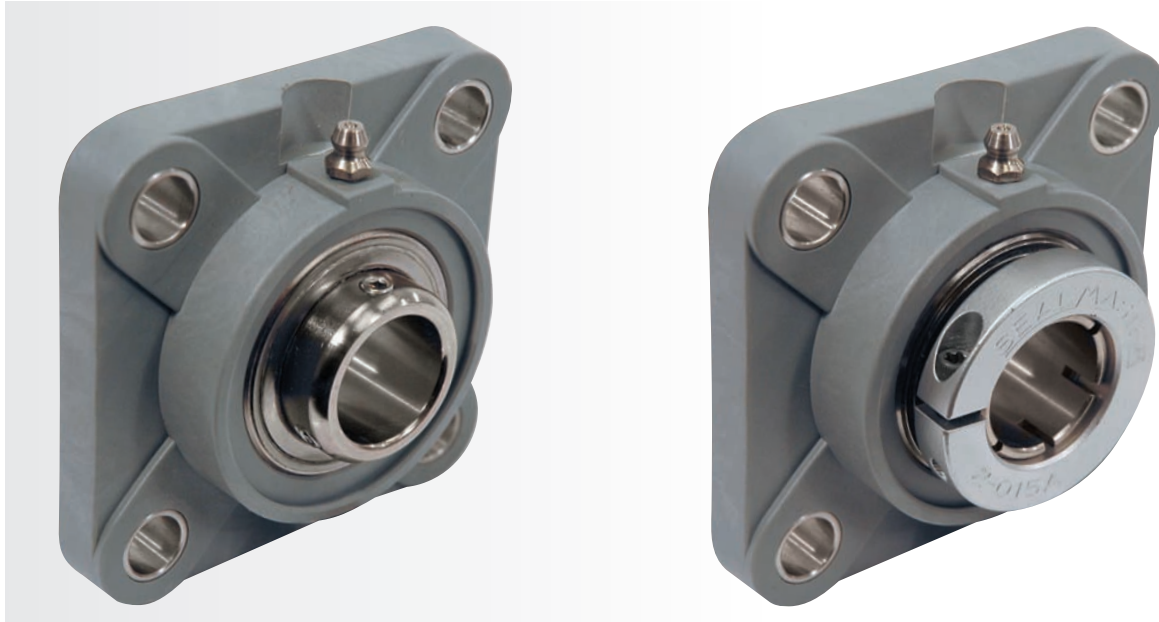

CRFC-PN, CRFC-PN T Series 4 Bolt Flange / Composite Housings

Set Screw Description	SKWEZLOC Description	Shaft Size	A	B	C	D	E	J
CRFC-PN12	CRFC-PN12T	3/4	3 7/16	2 1/2	7/16	61/64	1 9/32	2 3/8
CRFC-PN16	CRFC-PN16T	1	3 51/64	2 3/4	17/32	1 5/64	1 7/16	2 21/32
CRFC-PN19	CRFC-PN19T	1 3/16	4 11/32	3 1/4	17/32	1 13/64	1 9/16	3 3/16
CRFC-PN20R	CRFC-PN20RT	1 1/4	4 11/32	3 1/4	17/32	1 13/64	1 9/16	3 3/16
CRFC-PN20	CRFC-PN20T	1 1/4	4 53/64	3 5/8	9/16	1 11/32	1 3/4	3 21/32
CRFC-PN23	CRFC-PN23T	1 7/16	4 53/64	3 5/8	9/16	1 11/32	1 3/4	3 21/32
CRFC-PN24	CRFC-PN24T	1 1/2	5 1/4	4	9/16	1 1/2	2 1/64	4 1/64

Mounted Ball Bearings

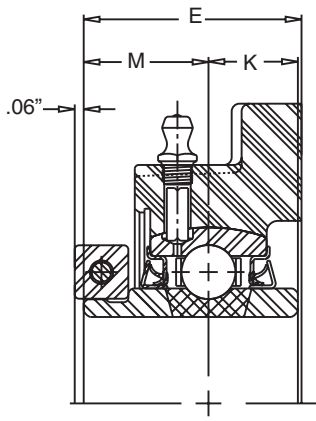

SKWEZLOC
LOCKING

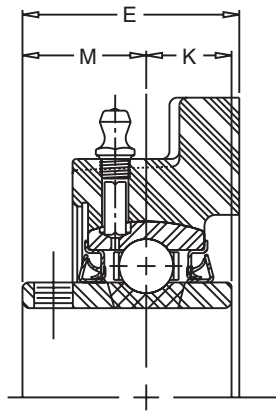

SET SCREW
LOCKING

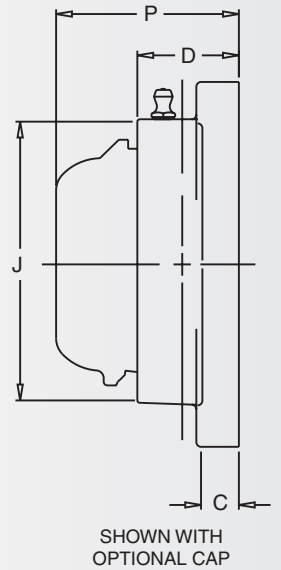
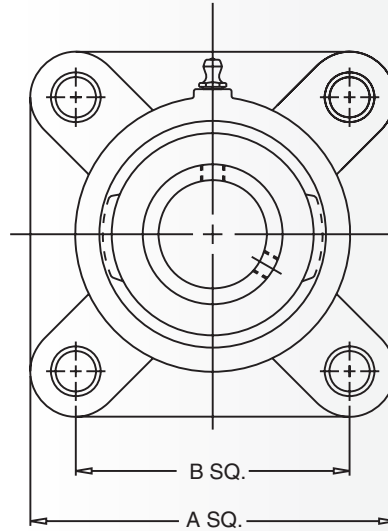

SHOWN WITH
OPTIONAL CAP

CRFC-PN, CRFC-PN T Series 4 Bolt Flange / Composite Housings

K	M	P	Bolt Size	Open Cap	Closed Cap	Backside Shield	Set Screw Description	SKWEZLOC Description
1/2	23/32	2 13/64	3/8	ECO-12	ECC-12	4BSS-12	CRFC-PN12	CRFC-PN12T
9/16	13/16	2 23/64	7/16	ECO-16	ECC-16	4BSS-16	CRFC-PN16	CRFC-PN16T
5/8	7/8	2 15/32	7/16	ECO-19	ECC-19	4BSS-19	CRFC-PN19	CRFC-PN19T
5/8	7/8	2 15/32	7/16	ECO-20R	ECC-19	4BSS-20R	CRFC-PN20R	CRFC-PN20RT
11/16	1	2 43/64	1/2	ECO-20	ECC-23	4BSS-20	CRFC-PN20	CRFC-PN20T
11/16	1	2 43/64	1/2	ECO-23	ECC-23	4BSS-23	CRFC-PN23	CRFC-PN23T
3/4	1 3/16	2 15/16	1/2	ECO-24	ECC-24	4BSS-24	CRFC-PN24	CRFC-PN24T

BEARINGS

Corrosion Resistant Engineered Solutions



CRES CRX-TREME *Mounted Ball Bearings*

The CRX-TREME design incorporates the most advanced technologies from a variety of industries to produce a mounted ball bearing unlike any other. Previously, engineers working to improve upon corrosion resistance utilized a variety of coatings and stainless steel grades. However, coatings wear away, chip or peel and complete uniform coverage may be difficult to obtain. Another common approach is to manufacture bearing races out of stainless steel materials. Some stainless steel such as 440C can be hardened to acceptable levels for anti-friction bearings but do not offer the best corrosion resistance. 316 stainless steel offers superior corrosion resistance compared to 440C or coatings. However, it cannot be hardened to acceptable levels for anti-friction bearing races.

The patented CRX-TREME bearing insert combines the hardenability and load carrying capability of 440C stainless steel with the corrosion resistance of 300 series stainless steel. With a CRX-TREME solution you no longer have to sacrifice load carrying capacity for corrosion resistance.

Now you can have both.



Nomenclature:

CRXPS - 16

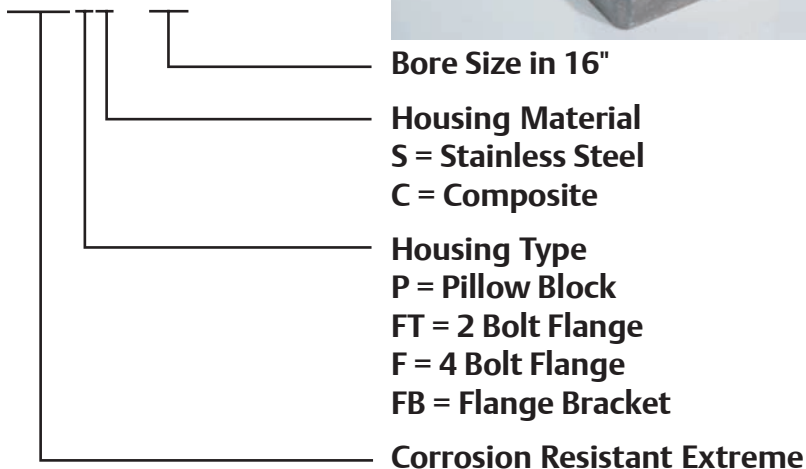

Mounted Ball Bearings

Components Material

Housing:	316 Passivated Stainless Steel or High Strength Composite
Bearing Races:	316/440C Stainless Custom Bi-Metal
Balls:	440C Stainless Steel
Retainer:	Unique Metal Land Riding Retainer
Seal:	High Performance Seal (HPS)
Flinger:	304 Stainless Steel
Set Screw:	17-4 PH Stainless Steel Diamond Faceted Cup Point
Grease Fitting:	303 Stainless Steel
Grease:	Sealmaster GoldPlex-FG

Features and Benefits

Insert

316/440C Stainless Steel Bi-Metal Races:	Provides a balance between load carrying capability and exceptional corrosion resistance.
High Performance Seal (HPS)	Multi-directional sealing with excellent chemical resistance.
17-4 PH Stainless Steel Set Screws:	Hardened material allows for increased tightening torque at installation.
H1 Food Grade Grease:	Non-toxic grease with superior corrosion resistance and excellent wash out properties.

Stainless Steel Housing

316 Passivated Stainless Steel:	Highest amount of corrosion resistance currently available for stainless steel bearing housings.
Advanced Casting Technology:	Investment cast process yields a smooth, easy to clean surface.
Solid Construction – Machined Base:	Minimal gaps, no fillings, smooth easy to clean surface.
Specialized Laser Identification:	Permanent brand and nomenclature marking.

Composite Housing

High Strength Composite:	High load capacity.
Solid Construction – Machined Base:	Minimal gaps, no filling, smooth easy to clean surface.
Reinforced Stainless Steel Bolt Ferrules:	Increased strength around bolt holes.
Specialized Unit Identification:	Permanent brand and nomenclature marking.

BEARINGS

Corrosion Resistant Engineered Solutions



CRX-TREME vs. 440C Stainless Steel Inserts

Salt Spray Test

Many of today's corrosion resistant, mounted bearings are constructed utilizing 400 series stainless steel material. While this material allows for proper ball path hardening, it is not as corrosion resistant as 300 series stainless steel. The revolutionary CRX-TREME design utilizes both 440C and 316 stainless steel materials. This design provides corrosion resistance and ball path hardenability.

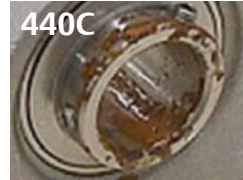

Competitor design - 90 hours



CRX-TREME design - 1000+ hours

Test Method:

The following salt spray test ASTM-117 (American Society for Testing and Materials) demonstrates the corrosion resistance capabilities of the CRX-TREME bearing. Each bearing was run in a salt fog chamber until the bearing reached a five percent surface corrosion.

CRX-TREME vs. Coated Inserts

Scratch Test

As corrosion resistant coatings peel or chip away, the bare steel substructure can quickly begin to corrode. This corrosion will then spread to adjacent sections effectively negating the corrosion resistant properties of the coating.

Since all exposed CRX-TREME race materials are constructed of 316 stainless steel, natural abrasion and/or deep penetrating gashes will have little effect on its corrosion resistant qualities.

Test Method:

Utilizing a standard shop lathe, a scratch approximately .03" wide (common thickness of a human fingernail) was applied to the inner race. The insert was then placed in a salt fog test chamber for 48 hours. The results demonstrate the highly corrosion resistant CRX-TREME design is not affected by wear, unlike competitive coatings.



Dodge Insert



Zinc Insert



CRX-TREME Insert

IT'S A FACT!

The CRX-TREME bearing inserts dramatically outperformed the competition in both the salt and scratch test.

Mounted Ball Bearings

316/440C Stainless Steel Patented Bi-Metal Insert

- 316 stainless steel rings with 440C stainless steel ball paths
- 440C ball paths are protected by the Sealmaster high performance seal (HPS) and Sealmaster specialized GoldPlex-FG grease
- 316 and 440C materials joined with an aerospace brazing process
- Hardened 440C ball path to maintain standard 440C bearing loads
- Passivated races (an acid wash that removes ferrous material from the stainless steel and helps improve the material's corrosion resistance)

Braze Process

Commonly used in aerospace applications, the brazing process joins the 316 grade and 440C grade stainless steels by melting a high strength, corrosion resistant filler material to metallurgically bond the components together. This strong, structure bond approximates the base material strength. To validate the strength of the braze joint the CRX-TREME insert was subject to thrust load replication tests. The braze joint consistently exceeded the bearing's thrust load capacity by almost 40 times.

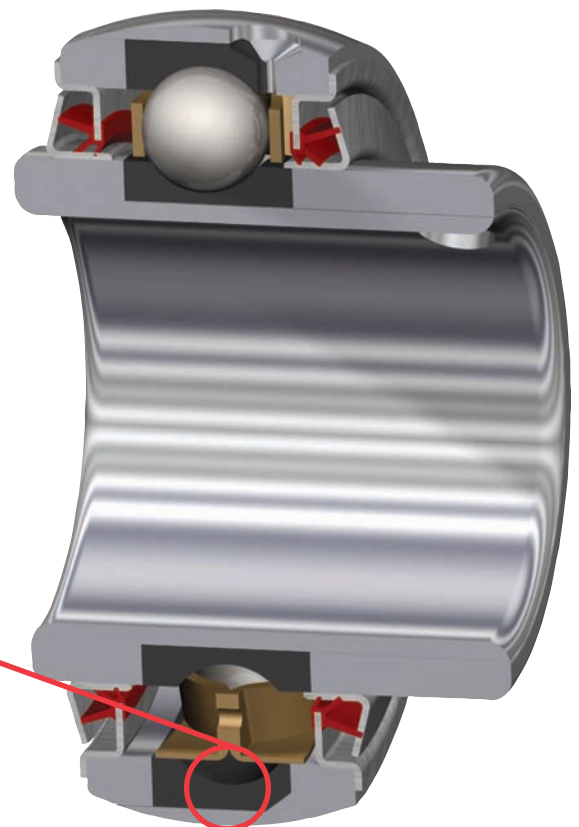

Sealmaster CRX-TREME Insert
(U.S. Patent No. 5,716,147)

BEARINGS

Corrosion Resistant Engineered Solutions



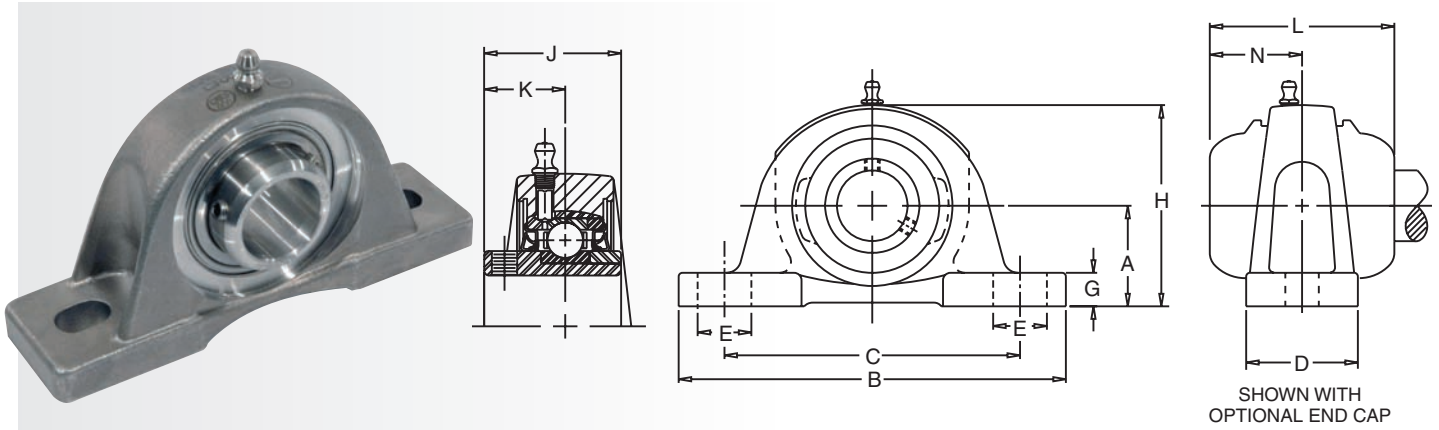

CRXPS Series Pillow Blocks / Stainless Steel Housings

CRX Description	Shaft Size	A	B	C MAX.	C MIN.	D	E	G	H	J	K	L	N	Bolt Size	Open Cap	Closed Cap	Backside Shield
CRXPS-16	1	1 7/16	5 1/2	4 1/2	3 3/4	1 1/2	3/4	1/2	2 13/16	1 3/8	13/16	3 15/32	1 47/64	3/8	ECO-16	ECC-16	N/A
CRXPS-19	1 3/16	1 11/16	6 1/2	5 1/16	4 7/16	1 7/8	13/16	9/16	3 3/8	1 1/2	7/8	3 19/32	1 51/64	1/2	ECO-19	ECC-19	N/A
CRXPS-20R	1 1/4	1 11/16	6 1/2	5 1/16	4 7/16	1 7/8	13/16	9/16	3 3/8	1 1/2	7/8	3 19/32	1 51/64	1/2	ECO-20R	ECC-19	N/A
CRXPS-20	1 1/4	1 7/8	6 9/16	5 5/16	4 11/16	1 7/8	13/16	5/8	3 3/4	1 11/16	1	3 27/32	1 59/64	1/2	ECO-20	ECC-23	N/A
CRXPS-23	1 7/16	1 7/8	6 9/16	5 5/16	4 11/16	1 7/8	13/16	5/8	3 3/4	1 11/16	1	3 27/32	1 59/64	1/2	ECO-23	ECC-23	N/A
CRXPS-24	1 1/2	1 15/16	7 1/4	5 7/8	4 7/8	2 1/8	1	11/16	3 15/16	1 15/16	1 3/16	4 7/32	2 7/64	1/2	ECO-24	ECC-24	N/A

Mounted Ball Bearings

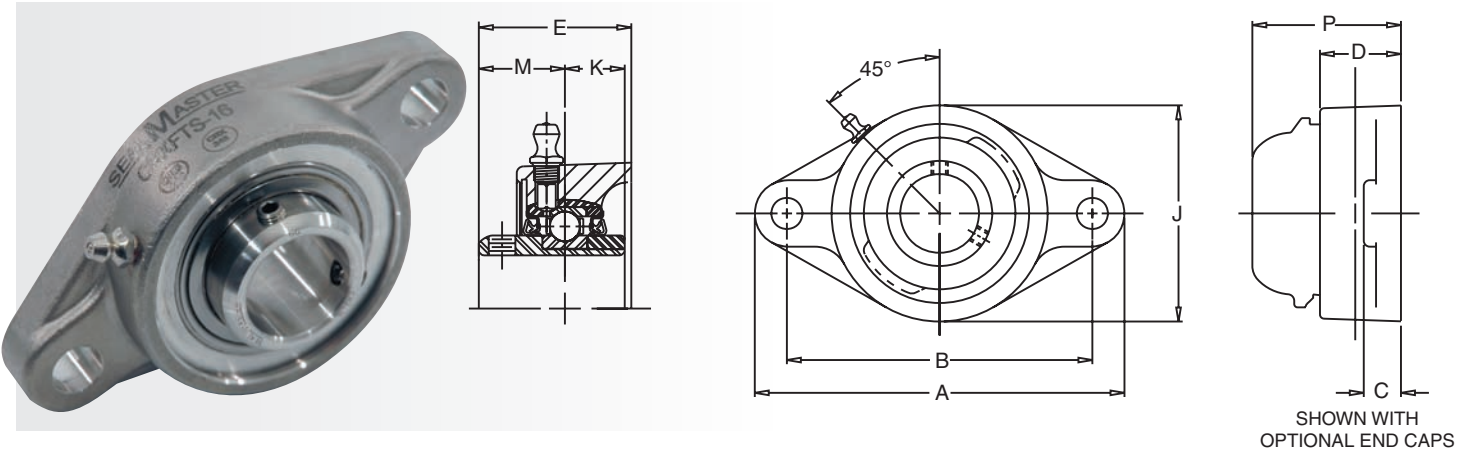

CRXFTS Series 2 Bolt Flange / Stainless Steel Housings

CRX Description	Shaft Size	A	B	C	D	E	J	K	M	P	Bolt Size	Open Cap	Closed Cap	Backside Shield
CRXFTS-16	1	4 7/8	3 57/64	17/32	1 5/64	1 7/16	2 3/4	9/16	13/16	2 23/64	7/16	ECO-16	ECC-16	2BSS-16
CRXFTS-19	1 3/16	5 9/16	4 19/32	17/32	1 7/32	1 9/16	3 1/4	5/8	7/8	2 31/64	7/16	ECO-19	ECC-19	2BSS-19
CRXFTS-20R	1 1/4	5 9/16	4 19/32	17/32	1 7/32	1 9/16	3 1/4	5/8	7/8	2 31/64	7/16	ECO-20R	ECC-19	2BSS-20R
CRXFTS-20	1 1/4	6 1/8	5 1/8	9/16	1 11/32	1 3/4	3 3/4	11/16	1	2 43/64	1/2	ECO-20	ECC-23	2BSS-20
CRXFTS-23	1 7/16	6 1/8	5 1/8	9/16	1 11/32	1 3/4	3 3/4	11/16	1	2 43/64	1/2	ECO-23	ECC-23	2BSS-23
CRXFTS-24	1 1/2	6 3/4	5 21/32	9/16	1 1/2	2 1/64	4 1/8	3/4	1 3/16	2 15/16	1/2	ECO-24	ECC-24	2BSS-24

BEARINGS

Corrosion Resistant Engineered Solutions



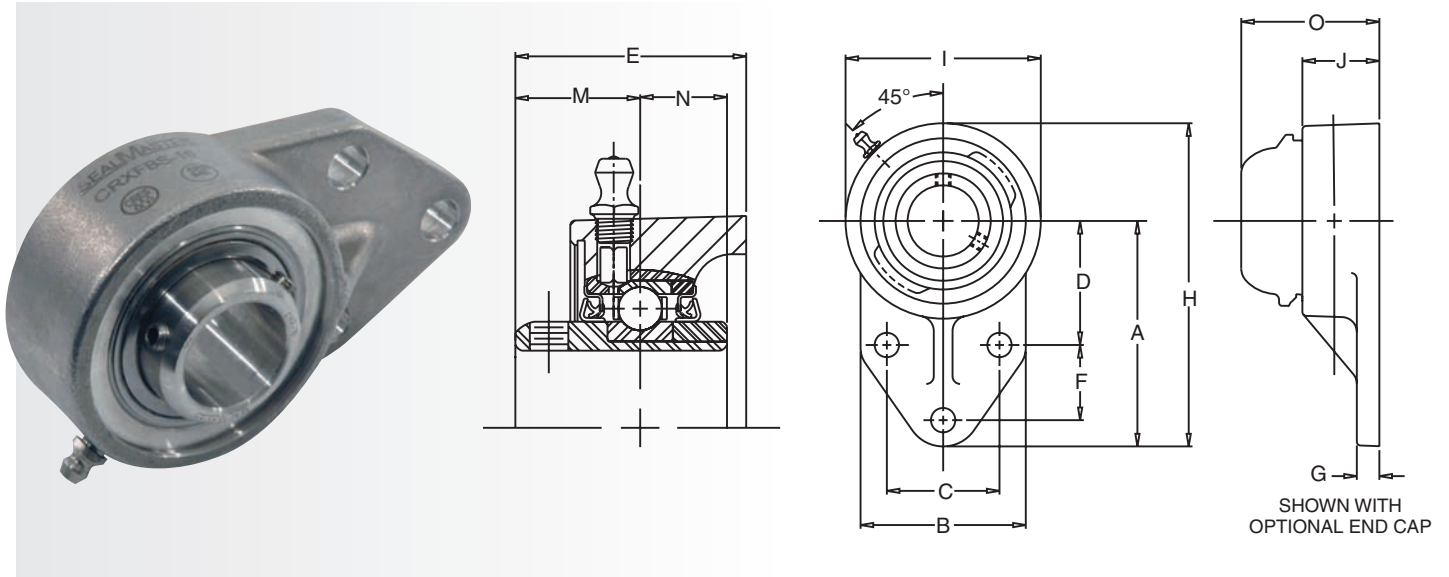

CRXFBS Series Flange Bracket / Stainless Steel Housings

CRX Description	Shaft Size	A	B	C	D	E	F	G	H	I	J	M	N	O	Bolt Size	Open Cap	Closed Cap	Backside Shield
CRXFBS-16	1	3 3/8	2 1/2	1 5/8	1 13/16	1 1/2	1 1/8	3/8	4 3/4	2 3/4	1 9/64	23/32	1/2	2 17/64	3/8	ECO-16	ECC-16	N/A
CRXFBS-19	1 3/16	3 3/4	2 3/4	1 7/8	2 1/16	1 5/8	1 1/4	3/8	5 3/8	3 1/4	1 9/32	13/16	9/16	2 13/32	3/8	ECO-19	ECC-19	N/A
CRXFBS-20R	1 1/4	3 3/4	2 3/4	1 7/8	2 1/16	1 5/8	1 1/4	3/8	5 3/8	3 1/4	1 9/32	7/8	5/8	2 35/64	3/8	ECO-20R	ECC-19	N/A
CRXFBS-20	1 1/4	4 1/4	3 1/4	2	2 3/8	1 7/8	1 1/4	1/2	6 1/8	3 3/4	1 15/32	7/8	5/8	2 35/64	1/2	ECO-20	ECC-23	N/A
CRXFBS-23	1 7/16	4 1/4	3 1/4	2	2 3/8	1 7/8	1 1/4	1/2	6 1/8	3 3/4	1 15/32	1	11/16	2 51/64	1/2	ECO-23	ECC-23	N/A

Mounted Ball Bearings

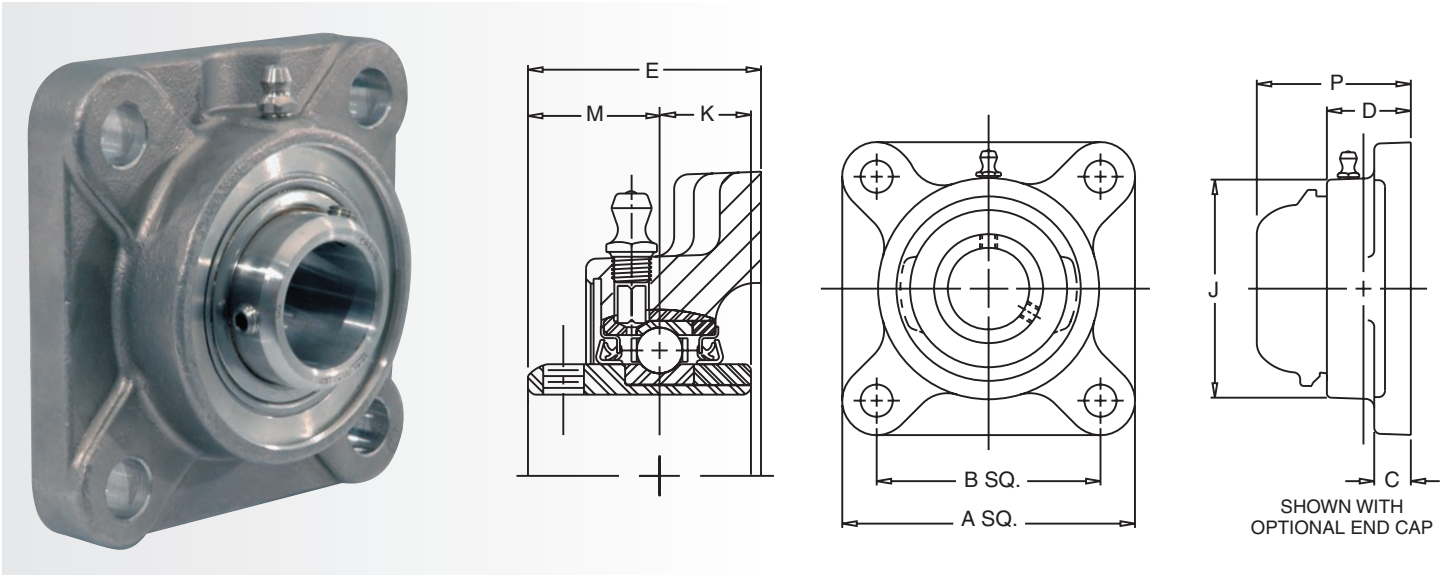

CRXFS Series 4 Bolt Flange / Stainless Steel Housings

CRX Description	Shaft Size	A	B	C	D	E	J	K	M	P	Bolt Size	Open Cap	Closed Cap	Backside Shield
CRXFS-16	1	3 3/4	2 3/4	17/32	1 5/64	1 7/16	2 45/64	9/16	13/16	2 23/64	7/16	ECO-16	ECC-16	4BSS-16
CRXFS-19	1 3/16	4 1/4	3 1/4	17/32	1 7/32	1 9/16	3 13/64	5/8	7/8	2 31/16	7/16	ECO-19	ECC-19	4BSS-19
CRXFS-20R	1 1/4	4 1/4	3 1/4	17/32	1 7/32	1 9/16	3 13/64	5/8	7/8	2 31/64	7/16	ECO-20R	ECC-19	4BSS-20R
CRXFS-20	1 1/4	4 5/8	3 5/8	9/16	1 11/32	1 3/4	3 3/4	11/16	1	2 43/64	1/2	ECO-20	ECC-23	4BSS-20
CRXFS-23	1 7/16	4 5/8	3 5/8	9/16	1 11/32	1 3/4	3 3/4	11/16	1	2 43/64	1/2	ECO-23	ECC-23	4BSS-23
CRXFS-24	1 1/2	5 1/8	4	9/16	1 1/2	2 1/64	4 5/64	3/4	1 3/16	2 15/16	1/2	ECO-24	ECC-24	4BSS-24

BEARINGS

Corrosion Resistant Engineered Solutions



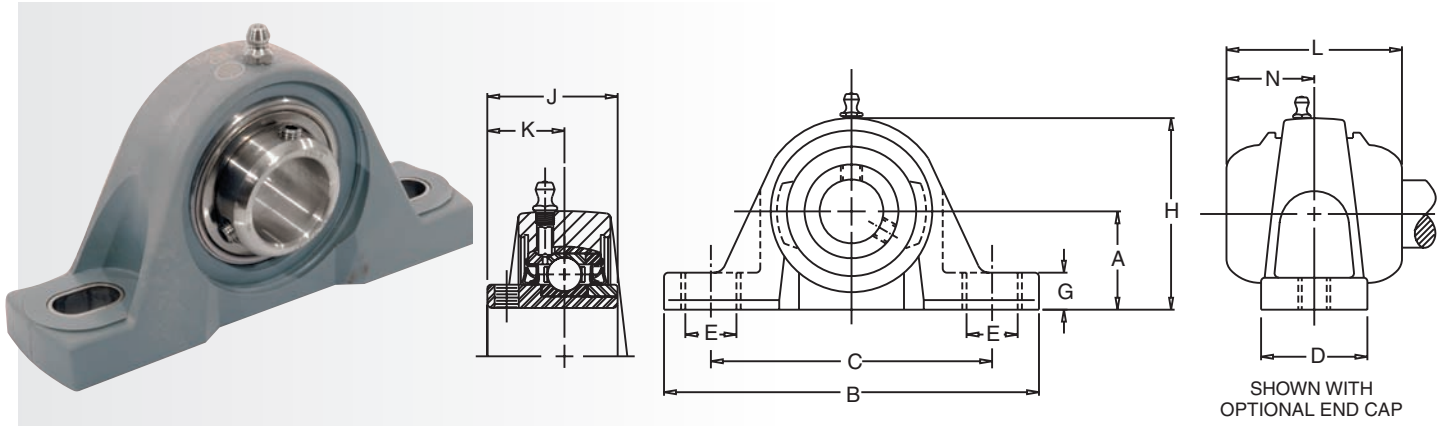

CRXPC Series Pillow Blocks / Composite Housing

CRX Description	Shaft Size	A	B	C MAX.	C MIN.	D	E	G	H	J	K	L	N	Bolt Size	Open Cap	Closed Cap	Backside Shield
CRXPC-16	1	1 7/16	5 1/2	4 1/2	3 3/4	1 1/2	3/4	9/16	2 13/16	1 3/8	13/16	3 15/32	1 47/64	3/8	ECO-16	ECC-16	N/A
CRXPC-19	1 3/16	1 11/16	6 1/2	5 1/16	4 7/16	1 7/8	13/16	11/16	3 21/64	1 1/2	7/8	3 19/32	1 51/64	1/2	ECO-19	ECC-19	N/A
CRXPC-20R	1 1/4	1 11/16	6 1/2	5 1/16	4 7/16	1 7/8	13/16	11/16	3 21/64	1 1/2	7/8	3 19/32	1 51/64	1/2	ECO-20R	ECC-19	N/A
CRXPC-20	1 1/4	1 7/8	6 9/16	5 5/16	4 11/16	1 7/8	13/16	11/16	3 3/4	1 11/16	1	3 27/32	1 59/64	1/2	ECO-20	ECC-23	N/A
CRXPC-23	1 7/16	1 7/8	6 9/16	5 5/16	4 11/16	1 7/8	13/16	11/16	3 3/4	1 11/16	1	3 27/32	1 59/64	1/2	ECO-23	ECC-23	N/A
CRXPC-24	1 1/2	1 15/16	7 1/4	5 11/16	5 1/16	2 1/8	13/16	11/16	4 1/64	1 15/16	1 3/16	4 7/32	2 7/64	1/2	ECO-24	ECC-24	N/A

Mounted Ball Bearings

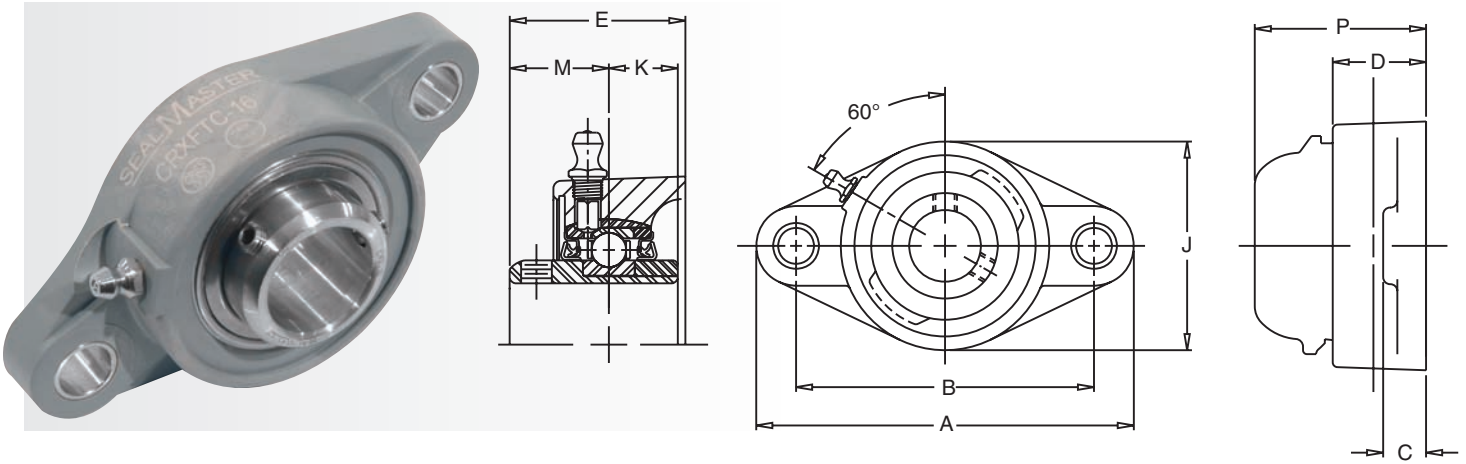

CRXFTC Series 2 Bolt Flange / Composite Housings

SHOWN WITH
OPTIONAL END CAP

CRX Description	Shaft Size	A	B	C	D	E	J	K	M	P	Bolt Size	Open Cap	Closed Cap	Backside Shield
CRXFTC-16	1	4 15/16	3 57/64	17/32	1 5/64	1 7/16	2 23/32	9/16	1 3/16	2 23/64	7/16	ECO-16	ECC-16	2BSS-16
CRXFTC-19	1 3/16	5 11/16	4 19/32	17/32	1 7/32	1 9/16	3 1/4	5/8	7/8	2 31/64	7/16	ECO-19	ECC-19	2BSS-19
CRXFTC-20R	1 1/4	5 11/16	4 19/32	17/32	1 7/32	1 9/16	3 1/4	5/8	7/8	2 31/64	7/16	ECO-20R	ECC-19	2BSS-20R
CRXFTC-20	1 1/4	6 21/64	5 1/8	9/16	1 11/32	1 3/4	3 45/64	11/16	1	2 43/64	1/2	ECO-20	ECC-23	2BSS-20
CRXFTC-23	1 7/16	6 21/64	5 1/8	9/16	1 11/32	1 3/4	3 45/64	11/16	1	2 43/64	1/2	ECO-23	ECC-23	2BSS-23
CRXFTC-24	1 1/2	6 29/32	5 21/32	9/16	1 1/2	2 1/64	4 7/64	3/4	1 3/16	2 15/16	1/2	ECO-24	ECC-24	2BSS-24

BEARINGS

Corrosion Resistant Engineered Solutions



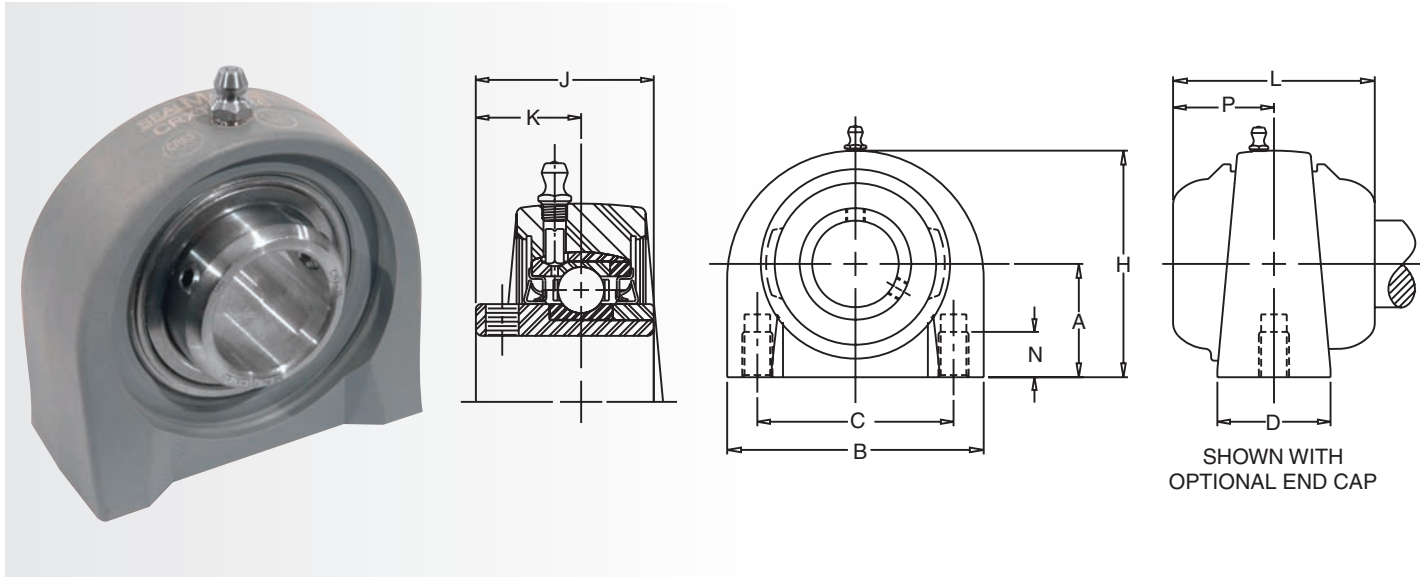

CRXTBC Series Tapped Base / Composite Housing

CRX Description	Shaft Size	A	B	C	D	H	J	K	L	N	P	Bolt Size	Open Cap	Closed Cap	Backside Shield
CRXTBC-16	1	1 7/16	3	2	1 1/2	2 13/16	1 3/8	13/16	3 15/32	1/2	1 47/64	3/8-16	ECO-16	ECC-16	N/A
CRXTBC-19	1 3/16	1 11/16	4	3	1 1/2	3 3/8	1 1/2	7/8	3 19/32	5/8	1 51/64	7/16-14	ECO-19	ECC-19	N/A
CRXTBC-20R	1 1/4	1 11/16	4	3	1 1/2	3 3/8	1 1/2	7/8	3 19/32	5/8	1 51/64	7/16-14	ECO-20R	ECC-19	N/A
CRXTBC-20	1 1/4	1 7/8	4 1/4	3 1/4	1 7/8	3 3/4	1 11/16	1	3 27/32	3/4	1 59/64	1/2-13	ECO-20	ECC-23	N/A
CRXTBC-23	1 7/16	1 7/8	4 1/4	3 1/4	1 7/8	3 3/4	1 11/16	1	3 27/32	3/4	1 59/64	1/2-13	ECO-23	ECC-23	N/A
CRXTBC-24	1 1/2	1 15/16	4 5/8	3 1/2	1 7/8	3 15/16	1 15/16	1 3/16	4 7/32	3/4	2 7/64	1/2-13	ECO-24	ECC-24	N/A

Mounted Ball Bearings

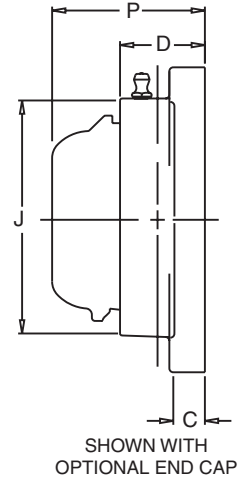
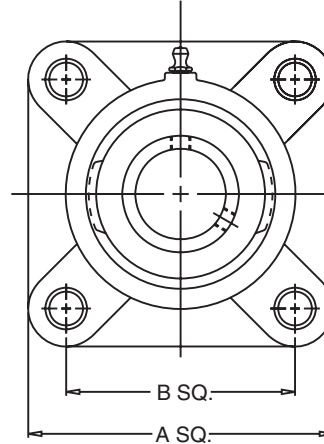
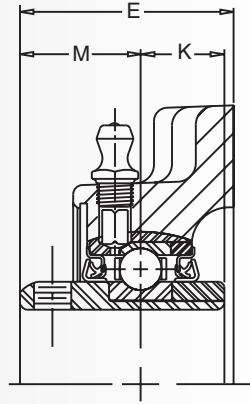

CRXFC Series 4 Bolt Flange / Composite Housings

CRX Description	Shaft Size	A	B	C	D	E	J	K	M	P	Bolt Size	Open Cap	Closed Cap	Backside Shield
CRXFC-16	1	3 51/64	2 3/4	17/32	1 5/64	1 7/16	2 21/32	9/16	13/16	2 23/64	7/16	ECO-16	ECC-16	4BSS-16
CRXFC-19	1 3/16	4 11/32	3 1/4	17/32	1 7/32	1 9/16	3 3/16	5/8	7/8	2 15/32	7/16	ECO-19	ECC-19	4BSS-19
CRXFC-20R	1 1/4	4 11/32	3 1/4	17/32	1 7/32	1 9/16	3 3/16	5/8	7/8	2 15/32	7/16	ECO-20R	ECC-19	4BSS-20R
CRXFC-20	1 1/4	4 53/64	3 5/8	9/16	1 11/32	1 3/4	3 21/32	11/16	1	2 43/64	1/2	ECO-20	ECC-23	4BSS-20
CRXFC-23	1 7/16	4 53/64	3 5/8	9/16	1 11/32	1 3/4	3 21/32	11/16	1	2 43/64	1/2	ECO-23	ECC-23	4BSS-23
CRXFC-24	1 1/2	5 1/4	4	9/16	1 1/2	2 1/64	4 1/64	3/4	1 3/16	2 15/16	1/2	ECO-24	ECC-24	4BSS-24

BEARINGS

Corrosion Resistant Engineered Solutions



CRES CZ Mounted Ball Bearings

CRES CZ bearings offer a composite housing, zinc dichromate coated insert, contact seal with zinc dichromate coated flinger and H1 food grade grease.



Nomenclature:

CPS - Z 216

- Bore Size in 1/16"
- 200 Series Insert
- Zinc Dichromate Coated Insert
- Set Screw
- Housing Type
 - P = Pillow Block
 - F2 = 2 Bolt Flange
 - F4 = 4 Bolt Flange
 - TB = Tapped Base
- Composite Housing Material

Mounted Ball Bearings

Components Material

Housing:	High Strength Composite
Bearing Races:	Zinc Dichromate Coated 52100 Steel
Balls:	52100 Steel
Retainer:	Nylon Ball Riding
Seal:	Single Lip Rubber Contact Seal
Flinger:	Zinc Dichromate Coated Stainless Steel
Set Screws:	300 Series Stainless Steel
Grease Fitting:	303 Stainless Steel
Grease:	H1 Food Grade Grease

Features and Benefits

Insert

Zinc Dichromate Coated Outer and Inner:	Cost effective, reliable performance.
Wide Inner Race:	Greater continuous shaft contact.
Honed Ball Paths:	Quiet operation with less vibration.
Outer Race Anti-Rotation Device:	Prevents outer race slippage in housing.
Molded Nitrile Rubber Contact Seal:	Contamination resistance and lubrication retention.
Zinc Dichromate Coated Flinger:	Additional barrier against contamination and washdown.
H1 Food Grade Grease:	Non-toxic grease with superior corrosion resistance and excellent wash out properties.

Housing

High Strength Composite:	High load capacity.
Solid Construction – Machined Base:	Minimal gaps, no fillings, smooth easy to clean surface.
Reinforced Stainless Steel Bolt Ferrules:	Increased strength around bolt holes.
Specialized Unit Identification:	Permanent brand and nomenclature marking.

Interchange

Housing Style	Browning	AMI®	MRC®	Peer®
Pillow Block	CPS-Z200	UCPPL200-MZ2	CPB100-ZM	ZUCP200-PBT
4 Bolt Flange	CF4S-Z200	UCFPL200-MZ2	C4F100-ZM	ZUCF200-PBT
2 Bolt Flange	CF2S-Z200	UCNFL200-MZ2	C2F100-ZM	ZUCFT200-PBT
Tapped Base	CTBS-Z200	UCTBL200-MZ2	CTB100-ZM	ZUCPA200-PBT

The following trade names, trademarks and/or registered trademarks are used in this material by Emerson Power Transmission Corporation for comparison purposes only, are NOT owned by Emerson Power Transmission Corporation and are believed to be owned by the following parties: AMI is a registered trademark of ASAHI Tec Corp. of Japan; MRC is a registered trademark of SKF USA Inc. ; Peer is a registered trademark of Peer Bearing Company.

BEARINGS

Corrosion Resistant Engineered Solutions



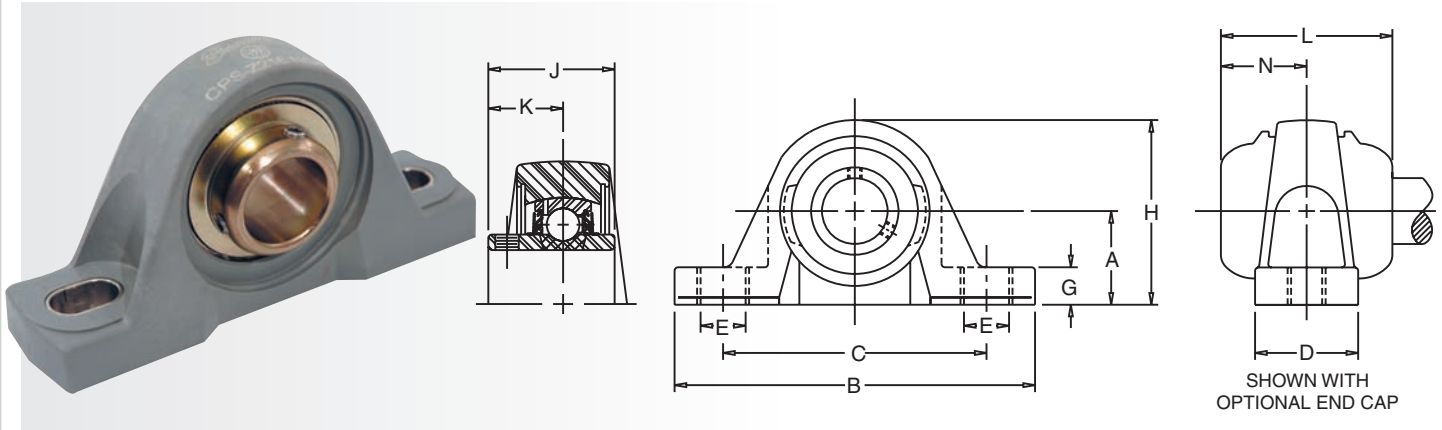

CPS-Z NGF Series Pillow Blocks / Composite Housing

CRES CZ Description	Shaft Size	A	B	C Max.	C Min.	D	E	G	H	J	K	L	N	Bolt Size	Open Cap	Closed Cap	Backside Shield
CPS-Z212 NGF	3/4	1 5/16	5	4 1/8	3 3/8	1 1/2	3/4	9/16	2 35/64	1 7/32	23/32	3 9/32	1 41/64	3/8	ECO-12	ECC-12	N/A
CPS-Z216 NGF	1	1 7/16	5 1/2	4 1/2	3 3/4	1 1/2	3/4	9/16	2 51/64	1 3/8	13/16	3 15/32	1 47/64	3/8	ECO-16	ECC-16	N/A
CPS-Z219 NGF	1 3/16	1 11/16	6 1/2	5 1/16	4 7/16	1 7/8	13/16	11/16	3 21/64	1 1/2	7/8	3 19/32	1 51/64	1/2	ECO-19	ECC-19	N/A
CPS-Z220S NGF	1 1/4	1 11/16	6 1/2	5 1/16	4 7/16	1 7/8	13/16	11/16	3 21/64	1 1/2	7/8	3 19/32	1 51/64	1/2	ECO-20R	ECC-19	N/A
CPS-Z220 NGF	1 1/4	1 7/8	6 9/16	5 5/16	4 11/16	1 7/8	13/16	11/16	3 3/4	1 11/16	1	3 27/32	1 59/64	1/2	ECO-20	ECC-23	N/A
CPS-Z223 NGF	1 7/16	1 7/8	6 9/16	5 5/16	4 11/16	1 7/8	13/16	11/16	3 3/4	1 11/16	1	3 27/32	1 59/64	1/2	ECO-23	ECC-23	N/A
CPS-Z224 NGF	1 1/2	1 15/16	7 1/4	5 11/16	5 1/16	2 1/8	13/16	11/16	4 1/64	1 15/16	1 3/16	4 7/32	2 7/64	1/2	ECO-24	ECC-24	N/A

CRES CZ regreaseable options are available by removing the NGF suffix.

Mounted Ball Bearings

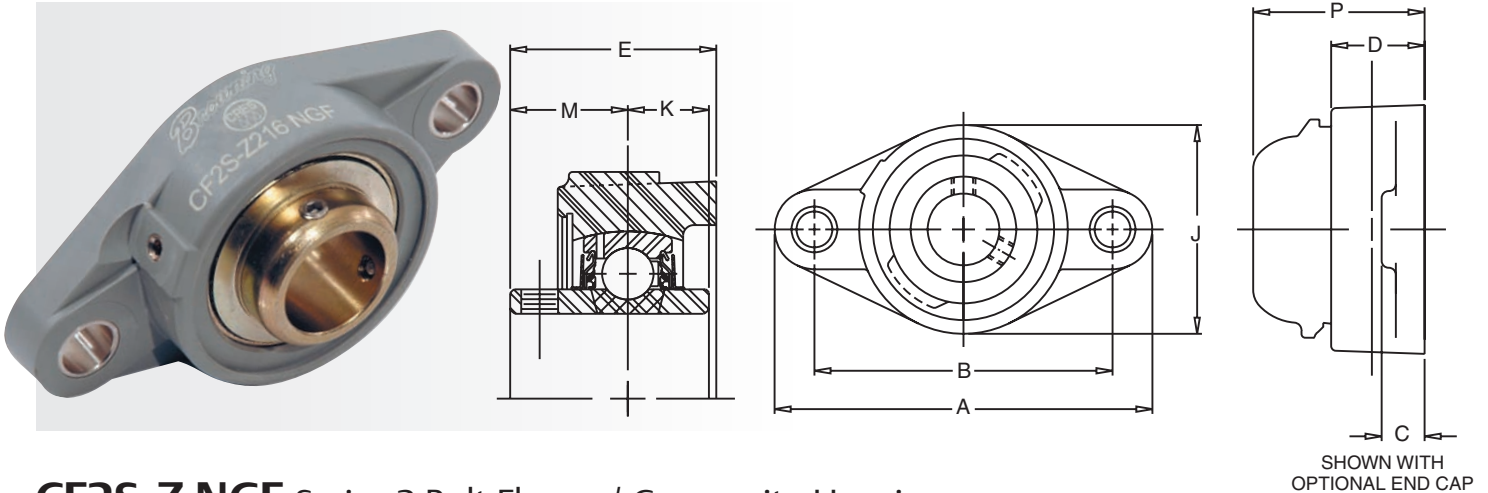

CF2S-Z NGF Series 2 Bolt Flange / Composite Housing

CRES CZ Description	Shaft Size	A	B	C	D	E	J	K	M	P	Bolt Size	Open Cap	Closed Cap	Backside Shield
CF2S-Z212 NGF	3/4	4 15/32	3 17/32	7/16	31/32	1 9/32	2 7/16	1/2	23/32	2 13/64	3/8	ECO-12	ECC-12	2BSS-12
CF2S-Z216 NGF	1	4 15/16	3 57/64	17/32	1 5/64	1 7/16	2 23/32	9/16	13/16	2 23/64	7/16	ECO-16	ECC-16	2BSS-16
CF2S-Z219 NGF	1 3/16	5 11/16	4 19/32	17/32	1 7/32	1 9/16	3 1/4	5/8	7/8	2 31/64	7/16	ECO-19	ECC-19	2BSS-19
CF2S-Z220S NGF	1 1/4	5 11/16	4 19/32	17/32	1 7/32	1 9/16	3 1/4	5/8	7/8	2 31/64	7/16	ECO-20R	ECC-19	2BSS-20R
CF2S-Z220 NGF	1 1/4	6 21/64	5 1/8	9/16	1 11/32	1 3/4	3 45/64	11/16	1	2 43/64	1/2	ECO-20	ECC-23	2BSS-20
CF2S-Z223 NGF	1 7/16	6 21/64	5 1/8	9/16	1 11/32	1 3/4	3 45/64	11/16	1	2 43/64	1/2	ECO-23	ECC-23	2BSS-23
CF2S-Z224 NGF	1 1/2	6 29/32	5 21/32	9/16	1 1/2	2 1/64	4 7/64	3/4	1 3/16	2 15/16	1/2	ECO-24	ECC-24	2BSS-24

CRES CZ regreaseable options are available by removing the NGF suffix.

BEARINGS

Corrosion Resistant Engineered Solutions



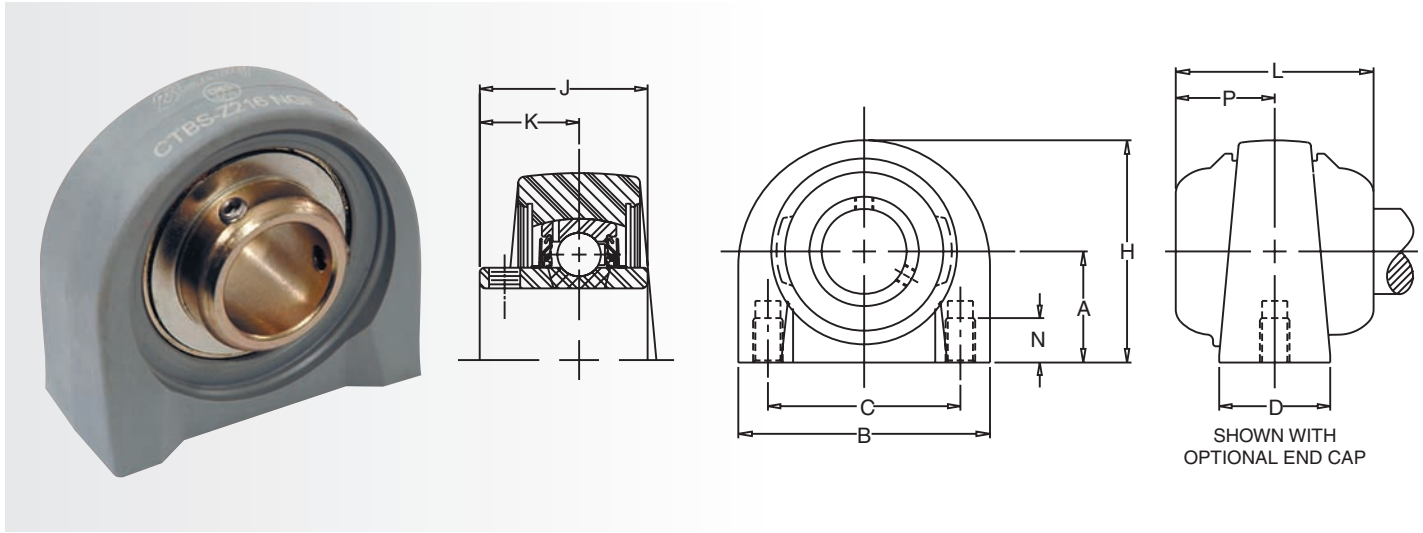

CTBS-Z NGF Series Tapped Base / Composite Housing

CRES CZ Description	Shaft Size	A	B	C	D	H	J	K	L	N	P	Bolt Size	Open Cap	Closed Cap	Backside Shield
CTBS-Z212 NGF	3/4	1 5/16	3 1/8	2	1 1/2	2 9/16	1 7/32	23/32	3 9/32	1/2	1 41/64	3/8-16	ECO-12	ECC-12	N/A
CTBS-Z216 NGF	1	1 7/16	3	2	1 1/2	2 13/16	1 3/8	13/16	3 15/32	1/2	1 47/64	3/8-16	ECO-16	ECC-16	N/A
CTBS-Z219 NGF	1 3/16	1 11/16	4	3	1 1/2	3 3/8	1 1/2	7/8	3 19/32	5/8	1 51/64	7/16-14	ECO-19	ECC-19	N/A
CTBS-Z220S NGF	1 1/4	1 11/16	4	3	1 1/2	3 3/8	1 1/2	7/8	3 19/32	5/8	1 51/64	7/16-14	ECO-20R	ECC-19	N/A
CTBS-Z220 NGF	1 1/4	1 7/8	4 1/4	3 1/4	1 7/8	3 3/4	1 11/16	1	3 27/32	3/4	1 59/64	1/2-13	ECO-20	ECC-23	N/A
CTBS-Z223 NGF	1 7/16	1 7/8	4 1/4	3 1/4	1 7/8	3 3/4	1 11/16	1	3 27/32	3/4	1 59/64	1/2-13	ECO-23	ECC-23	N/A
CTBS-Z224 NGF	1 1/2	1 15/16	4 5/8	3 1/2	1 7/8	3 15/16	1 15/16	1 3/16	4 7/32	3/4	2 7/64	1/2-13	ECO-24	ECC-24	N/A

CRES CZ regreaseable options are available by removing the NGF suffix.

Mounted Ball Bearings

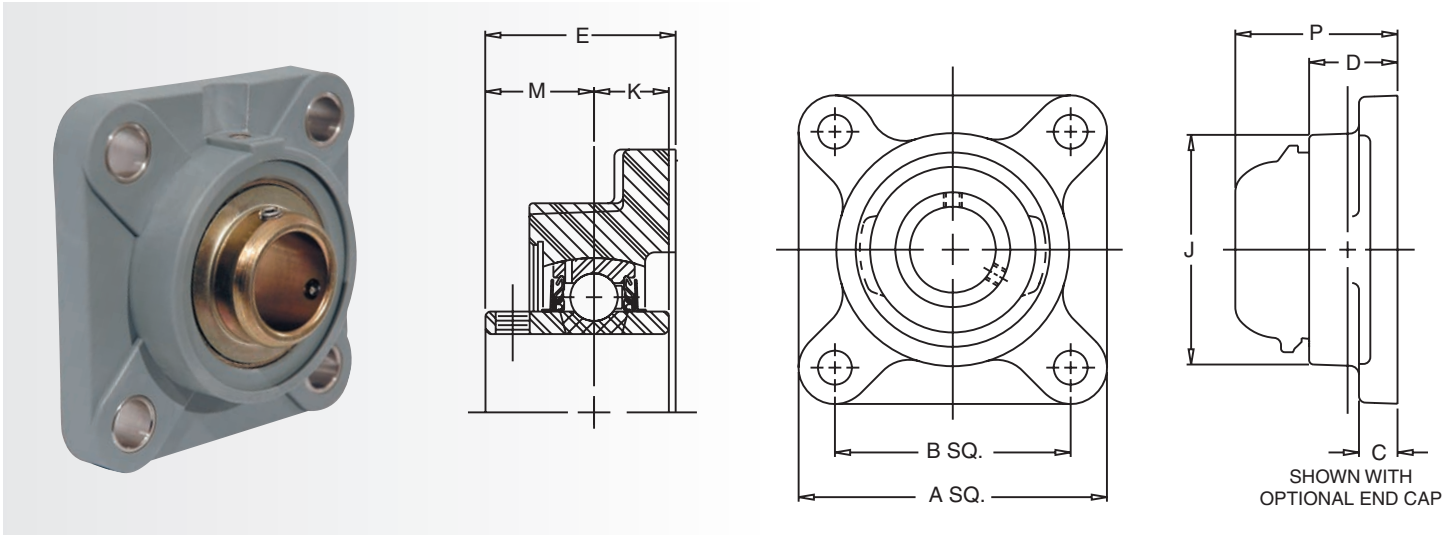

CF4S-Z NGF Series 4 Bolt Flange / Composite Housings

CRES CZ Description	Shaft Size	A	B	C	D	E	J	K	M	P	Bolt Size	Open Cap	Closed Cap	Backside Shield
CF4S-Z212 NGF	3/4	3 7/16	2 1/2	7/16	61/64	1 9/32	2 3/8	1/2	23/32	2 13/64	3/8	ECO-12	ECC-12	4BSS-12
CF4S-Z216 NGF	1	3 51/64	2 3/4	17/32	1 5/64	1 7/16	2 21/32	9/16	13/16	2 23/64	7/16	ECO-16	ECC-16	4BSS-16
CF4S-Z219 NGF	1 3/16	4 11/32	3 1/4	17/32	1 13/64	1 9/16	3 3/16	5/8	7/8	2 15/32	7/16	ECO-19	ECC-19	4BSS-19
CF4S-Z220S NGF	1 1/4	4 11/32	3 1/4	17/32	1 13/64	1 9/16	3 3/16	5/8	7/8	2 15/32	7/16	ECO-20R	ECC-19	4BSS-20R
CF4S-Z220 NGF	1 1/4	4 53/64	3 5/8	9/16	1 11/32	1 3/4	3 21/32	11/16	1	2 43/64	1/2	ECO-20	ECC-23	4BSS-20
CF4S-Z223 NGF	1 7/16	4 53/64	3 5/8	9/16	1 11/32	1 3/4	3 21/32	11/16	1	2 43/64	1/2	ECO-23	ECC-23	4BSS-23
CF4S-Z224 NGF	1 1/2	5 1/4	4	9/16	1 1/2	2 1/64	4 1/64	3/4	1 3/16	2 15/16	1/2	ECO-24	ECC-24	4BSS-24

CRES CZ regreaseable options are available by removing the NGF suffix.

BEARINGS

Corrosion Resistant Engineered Solutions



CRES CS Mounted Ball Bearings

CRES CS bearings offer a composite housing, stainless steel insert, contact seal with stainless steel flinger and H1 food grade grease.



Nomenclature:

CPS - S 216

- Bore Size in 1/16"
- 200 Series Insert
- Stainless Steel Insert
- Set Screw
- Housing Type
 - P = Pillow Block
 - F2 = 2 Bolt Flange
 - F4 = 4 Bolt Flange
 - TB = Tapped Base
- Composite Housing Material

Mounted Ball Bearings

Components Material

Housing:	High Strength Composite
Bearing Races:	440C Stainless Steel
Balls:	440C Stainless Steel
Retainer:	Nylon Ball Riding
Seal:	Single Lip Rubber Contact Seal
Flinger:	302 Stainless Steel
Set Screws:	300 Series Stainless Steel
Grease Fitting:	303 Stainless Steel
Grease:	H1 Food Grade Grease

Features and Benefits

Insert

440C Stainless Steel:	More corrosion resistant steel than common bearing steel.
Outer Race Anti-Rotation Device:	Prevents outer race slippage in housing.
Molded Silicone Rubber Contact Seal:	Contamination resistance and lubrication retention.
300 Series Stainless Steel Flinger:	Additional barrier against contamination and washdown.
H1 Food Grade Grease:	Non-toxic grease with good corrosion resistance and wash out properties.

Housing

High Strength Composite:	High load capacity.
Solid Construction – Machined Base:	Minimal gaps, no fillings, smooth easy to clean surface.
Reinforced Stainless Steel Bolt Ferrules:	Increased strength around bolt holes.
Specialized Unit Identification:	Permanent brand and nomenclature marking.

Interchange

Housing Style	Browning	AMI	MRC	FYH®	IPTCI®
Pillow Block	CPS-S200	MUCPPL200	CPB100-SS	UCP200-S6 PL	SUCTP200
4 Bolt Flange	CF4S-S200	MUCFPL200	C4F100-SS	UCF200-S6 PL	SUCTF200
2 Bolt Flange	CF2S-S200	MUCNFL200	C2F100-SS	UCFL200-S6 PL	SUCTFL200
Tapped Base	CTBS-S200	MUCTBL200	CTB100-SS	UCPAN200-S6 PL	SUCTPA200

The following trade names, trademarks and/or registered trademarks are used in this material by Emerson Power Transmission Corporation for comparison purposes only, are NOT owned by Emerson Power Transmission Corporation and are believed to be owned by the following parties: AMI is a registered trademark of ASAHI Tec Corp. of Japan; MRC is a registered trademark of SKF USA Inc. ; FYH is a registered trademark of Nippon Pillow Block Sales Co. LTD of Japan; IPTCI is a registered trademark of A Paul E. Robey Company.

BEARINGS

Corrosion Resistant Engineered Solutions



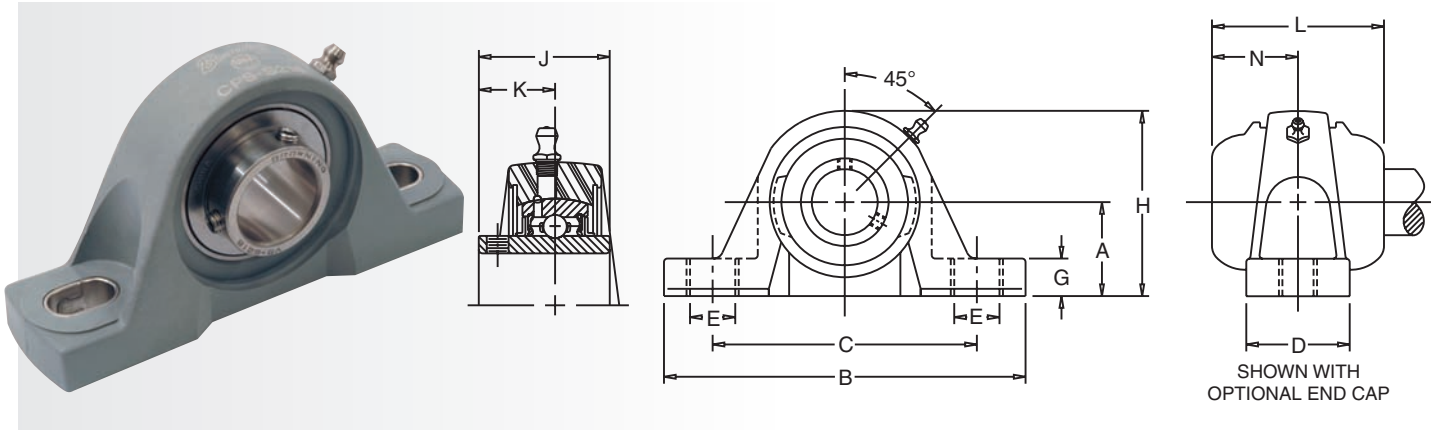

CPS-S Series Pillow Blocks / Composite Housings

CRES CS Description	Shaft Size	A	B	C Max.	C Min.	D	E	G	H	J	K	L	N	Bolt Size	Open Cap	Closed Cap	Backside Shield
CPS-S212	3/4	1 5/16	5	4 1/8	3 3/8	1 1/2	3/4	9/16	2 35/64	1 7/32	23/32	3 9/32	1 41/64	3/8	ECO-12	ECC-12	N/A
CPS-S216	1	1 7/16	5 1/2	4 1/2	3 3/4	1 1/2	3/4	9/16	2 51/64	1 11/32	25/32	3 15/32	1 47/64	3/8	ECO-16	ECC-16	N/A
CPS-S219	1 3/16	1 11/16	6 1/2	5 1/16	4 7/16	1 7/8	13/16	11/16	3 21/64	1 1/2	7/8	3 19/32	1 51/64	1/2	ECO-19	ECC-19	N/A
CPS-S220S	1 1/4	1 11/16	6 1/2	5 1/16	4 7/16	1 7/8	13/16	11/16	3 21/64	1 1/2	7/8	3 19/32	1 51/64	1/2	ECO-20R	ECC-19	N/A
CPS-S220	1 1/4	1 7/8	6 9/16	5 5/16	4 11/16	1 7/8	13/16	11/16	3 3/4	1 11/16	1	3 27/32	1 59/64	1/2	ECO-20	ECC-23	N/A
CPS-S223	1 7/16	1 7/8	6 9/16	5 5/16	4 11/16	1 7/8	13/16	11/16	3 3/4	1 11/16	1	3 27/32	1 59/64	1/2	ECO-23	ECC-23	N/A
CPS-S224	1 1/2	1 15/16	7 1/4	5 11/16	5 1/16	2 1/8	13/16	11/16	4 1/64	1 15/16	1 3/16	4 7/32	2 7/64	1/2	ECO-24	ECC-24	N/A

Mounted Ball Bearings

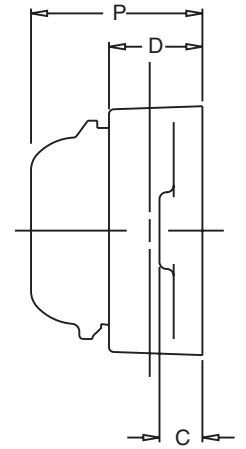
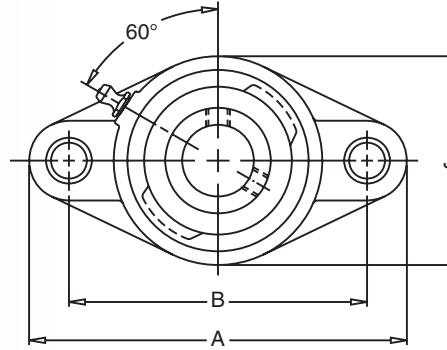
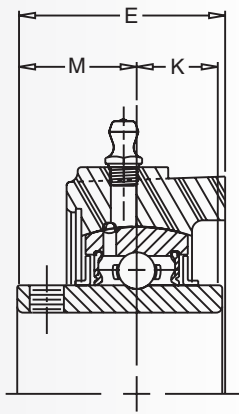

SHOWN WITH
OPTIONAL END CAP

CF2S-S Series 2 Bolt Flange / Composite Housings

CRES CS Description	Shaft Size	A	B	C	D	E	J	K	M	P	Bolt Size	Open Cap	Closed Cap	Backside Shield
CF2S-S212	3/4	4 15/32	3 17/32	7/16	31/32	1 9/32	2 7/16	1/2	23/32	2 13/64	3/8	ECO-12	ECC-12	2BSS-12
CF2S-S216	1	4 15/16	3 57/64	17/32	1 5/64	1 7/16	2 23/32	9/16	25/32	2 23/64	7/16	ECO-16	ECC-16	2BSS-16
CF2S-S219	1 3/16	5 11/16	4 19/32	17/32	1 7/32	1 9/16	3 1/4	5/8	7/8	2 31/64	7/16	ECO-19	ECC-19	2BSS-19
CF2S-S220S	1 1/4	5 11/16	4 19/32	17/32	1 7/32	1 9/16	3 1/4	5/8	7/8	2 31/64	7/16	ECO-20R	ECC-19	2BSS-20R
CF2S-S220	1 1/4	6 21/64	5 1/8	9/16	1 11/32	1 3/4	3 45/64	11/16	1	2 43/64	1/2	ECO-20	ECC-23	2BSS-20
CF2S-S223	1 7/16	6 21/64	5 1/8	9/16	1 11/32	1 3/4	3 45/64	11/16	1	2 43/64	1/2	ECO-23	ECC-23	2BSS-23
CF2S-S224	1 1/2	6 29/32	5 21/32	9/16	1 1/2	2 1/64	4 7/64	3/4	1 3/16	2 15/16	1/2	ECO-24	ECC-24	2BSS-24

BEARINGS

Corrosion Resistant Engineered Solutions



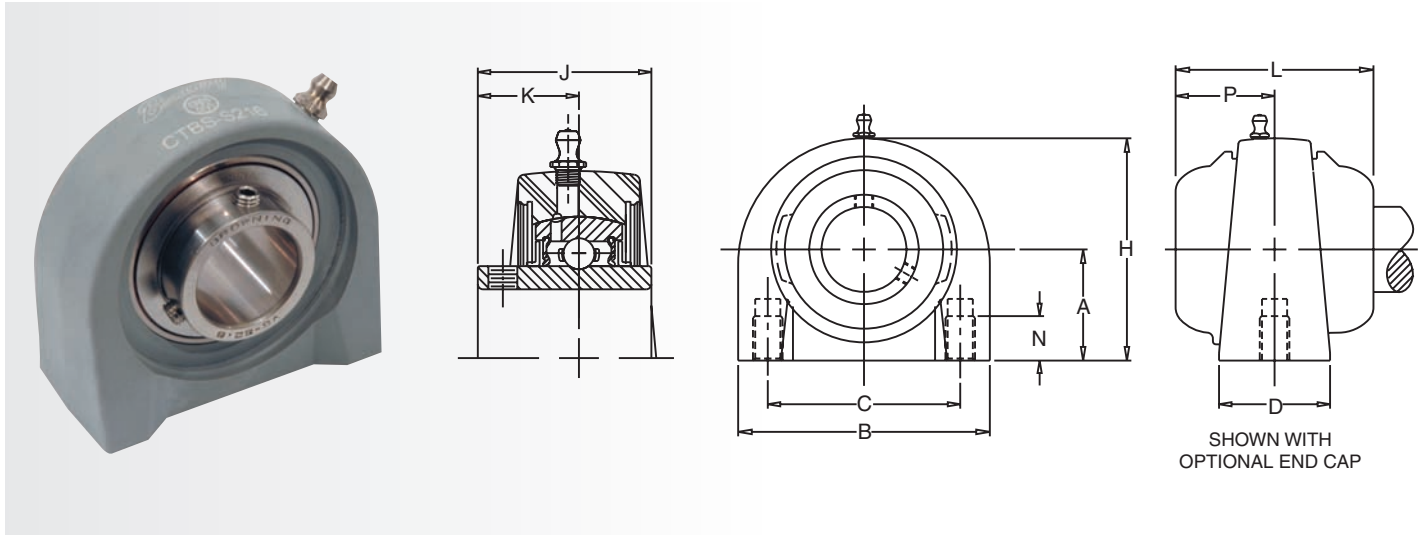

CTBS-S Series Tapped Base / Composite Housing

CRES CS Description	Shaft Size	A	B	C	D	H	J	K	L	N	P	Bolt Size	Open Cap	Closed Cap	Backside Shield
CTBS-S212	3/4	1 5/16	3 1/8	2	1 1/2	2 9/16	1 7/32	23/32	3 9/32	1/2	1 41/64	3/8-16	ECO-12	ECC-12	N/A
CTBS-S216	1	1 7/16	3	2	1 1/2	2 13/16	1 11/32	25/32	3 15/32	1/2	1 47/64	3/8-16	ECO-16	ECC-16	N/A
CTBS-S219	1 3/16	1 11/16	4	3	1 1/2	3 3/8	1 1/2	7/8	3 19/32	5/8	1 51/64	7/16-14	ECO-19	ECC-19	N/A
CTBS-S220S	1 1/4	1 11/16	4	3	1 1/2	3 3/8	1 1/2	7/8	3 19/32	5/8	1 51/64	7/16-14	ECO-20R	ECC-19	N/A
CTBS-S220	1 1/4	1 7/8	4 1/4	3 1/4	1 7/8	3 3/4	1 11/16	1	3 27/32	3/4	1 59/64	1/2-13	ECO-20	ECC-23	N/A
CTBS-S223	1 7/16	1 7/8	4 1/4	3 1/4	1 7/8	3 3/4	1 11/16	1	3 27/32	3/4	1 59/64	1/2-13	ECO-23	ECC-23	N/A
CTBS-S224	1 1/2	1 15/16	4 5/8	3 1/2	1 7/8	3 15/16	1 15/16	1 3/16	4 7/32	3/4	2 7/64	1/2-13	ECO-24	ECC-24	N/A

Mounted Ball Bearings

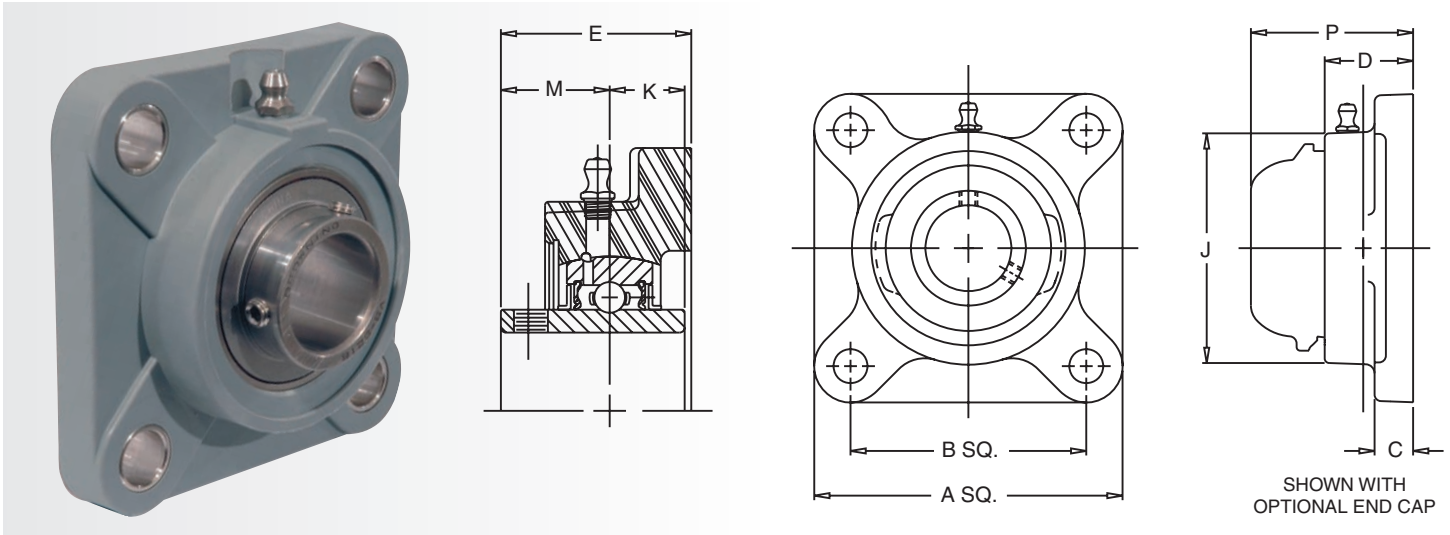

CF4S-S Series 4 Bolt Flange / Composite Housings

CRES CS Description	Shaft Size	A	B	C	D	E	J	K	M	P	Bolt Size	Open Cap	Closed Cap	Backside Shield
CF4S-S212	3/4	3 7/16	2 1/2	7/16	61/64	1 9/32	2 3/8	1/2	23/32	2 13/64	3/8	ECO-12	ECC-12	4BSS-12
CF4S-S216	1	3 51/64	2 3/4	17/32	1 5/64	1 7/16	2 21/32	9/16	25/32	2 23/64	7/16	ECO-16	ECC-16	4BSS-16
CF4S-S219	1 3/16	4 11/32	3 1/4	17/32	1 13/64	1 9/16	3 3/16	5/8	7/8	2 15/32	7/16	ECO-19	ECC-19	4BSS-19
CF4S-S220S	1 1/4	4 11/32	3 1/4	17/32	1 13/64	1 9/16	3 3/16	5/8	7/8	2 15/32	7/16	ECO-20R	ECC-19	4BSS-20R
CF4S-S220	1 1/4	4 53/64	3 5/8	9/16	1 11/32	1 3/4	3 21/32	11/16	1	2 43/64	1/2	ECO-20	ECC-23	4BSS-20
CF4S-S223	1 7/16	4 53/64	3 5/8	9/16	1 11/32	1 3/4	3 21/32	11/16	1	2 43/64	1/2	ECO-23	ECC-23	4BSS-23
CF4S-S224	1 1/2	5 1/4	4	9/16	1 1/2	2 1/64	4 1/64	3/4	1 3/16	2 15/16	1/2	ECO-24	ECC-24	4BSS-24

BEARINGS

Corrosion Resistant Engineered Solutions



CRES SS Mounted Ball Bearings

CRES SS bearings offer a stainless steel housing and insert, contact seal with stainless steel flinger and H1 food grade grease.



Nomenclature:

SPS - S 216

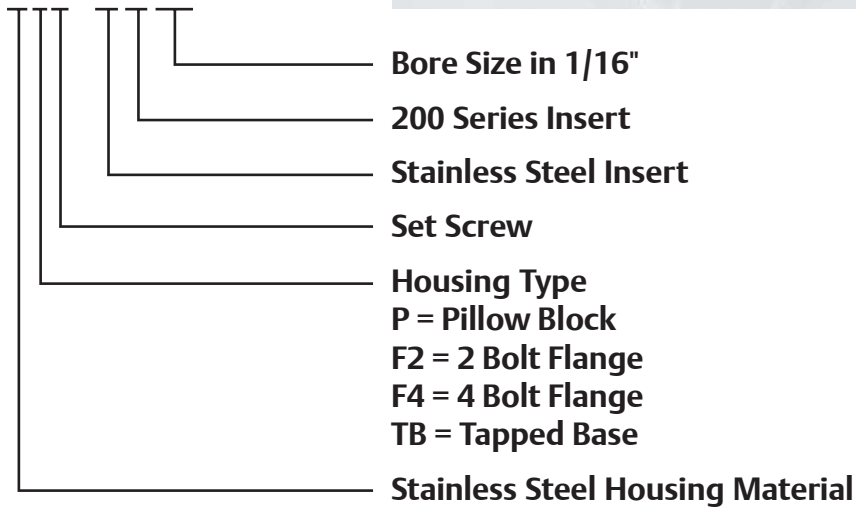

Mounted Ball Bearings

Components Material

Housing:	304 Stainless Steel
Bearing Races:	440C Stainless Steel
Balls:	440C Stainless Steel
Retainer:	302 Stainless Steel Ball Riding
Seal:	Single Lip Rubber Contact Seal
Flinger:	302 Stainless Steel
Set Screws:	300 Series Stainless Steel
Grease Fitting:	303 Stainless Steel
Grease:	H1 Food Grade Grease

Features and Benefits

Insert

440C Stainless Steel:	More corrosion resistant steel than common bearing steel.
Outer Race Anti-Rotation Device:	Prevents outer race slippage in housing.
Molded Silicone Rubber Contact Seal:	Contamination resistance and lubrication retention.
300 Series Stainless Steel Flinger:	Additional barrier against contamination and washdown.
H1 Food Grade Grease:	Non-toxic grease with good corrosion resistance and wash out properties.

Housing

304 Passivated Stainless Steel:	Good corrosion resistance.
Advanced Casting Technology:	Investment cast process yields a smooth, easy to clean surface.
Solid Construction – Machined Base:	Minimal entrapment points with no fillings.
Specialized Laser Identification:	Permanent brand and nomenclature marking.

Interchange

Housing Style	Browning	AMI	MRC	FYH®	IPTCI	PEER
Pillow Block	SPS-S200	MUCP200	SPB100SS	UCSP200-S6 PL	SUCSP200	SSUCP200
4 Bolt Flange	SF4S-S200	MUCF200	S4F100SS	UCSF200-S6 PL	SUCSF200	SSUCF200
2 Bolt Flange	SF2S-S200	MUCFL200	S2F100SS	UCSFL200-S6 PL	SUCSFL200	SSUCFL200
Tapped Base	STBS-S200	MUCTB200	STB100SS	N/A	SUCSPA200	SSUCPA200

The following trade names, trademarks and/or registered trademarks are used in this material by Emerson Power Transmission Corporation for comparison purposes only, are NOT owned by Emerson Power Transmission Corporation and are believed to be owned by the following parties: AMI is a registered trademark of ASAHI Tec Corp. of Japan; MRC is a registered trademark of SKF USA Inc. ; FYH is a registered trademark of Nippon Pillow Block Sales Co. LTD of Japan; IPTCI is a registered trademark of A Paul E. Robey Company; Peer is a registered trademark of Peer Bearing Company.

BEARINGS

Corrosion Resistant Engineered Solutions



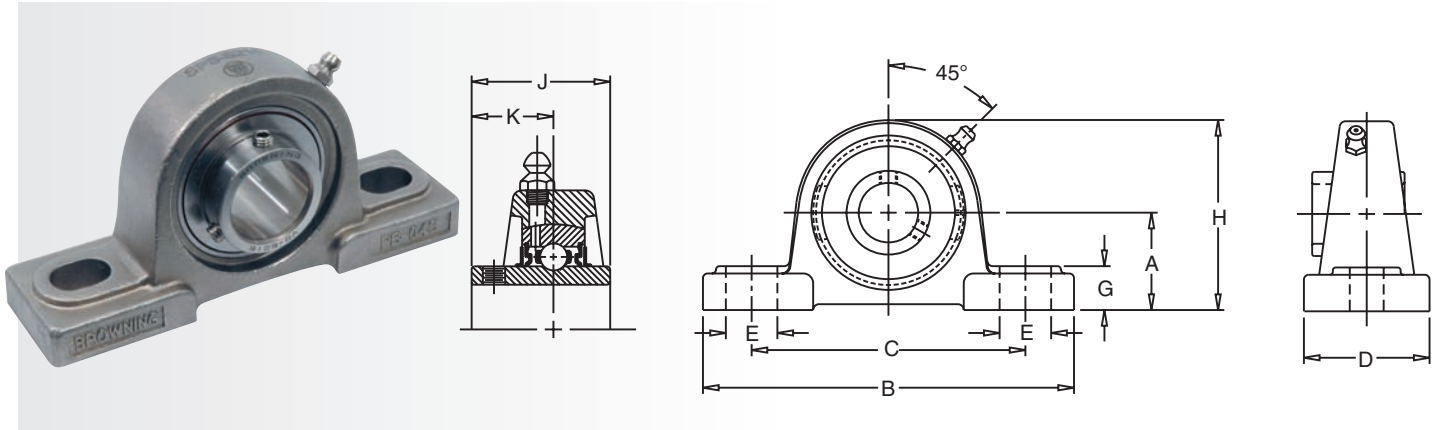

SPS-S Series Pillow Blocks / Stainless Steel Housings

CRES SS Description	Shaft Size	A	B	C MAX.	C MIN.	D	E	G	H	J	K	Bolt Size
SPS-S212	3/4	1 5/16	5	4 3/32	3 7/16	1 1/2	45/64	19/32	2 9/16	1 7/32	23/32	3/8
SPS-S216	1	1 7/16	5 1/2	4 15/32	3 51/64	1 1/2	53/64	5/8	2 51/64	1 11/32	25/32	3/8
SPS-S219	1 3/16	1 11/16	6 1/2	5 3/32	4 7/16	1 7/8	53/64	23/32	3 17/64	1 1/2	7/8	1/2
SPS-S220S	1 1/4	1 11/16	6 1/2	5 3/32	4 7/16	1 7/8	53/64	23/32	3 17/64	1 1/2	7/8	1/2
SPS-S220	1 1/4	1 7/8	6 9/16	5 3/8	4 5/8	1 7/8	7/8	3/4	3 45/64	1 11/16	1	1/2
SPS-S223	1 7/16	1 7/8	6 9/16	5 3/8	4 5/8	1 7/8	7/8	3/4	3 45/64	1 11/16	1	1/2
SPS-S224	1 1/2	1 15/16	7 15/64	5 51/64	5	2 1/8	29/32	3/4	3 15/16	1 15/16	1 3/16	1/2

Mounted Ball Bearings

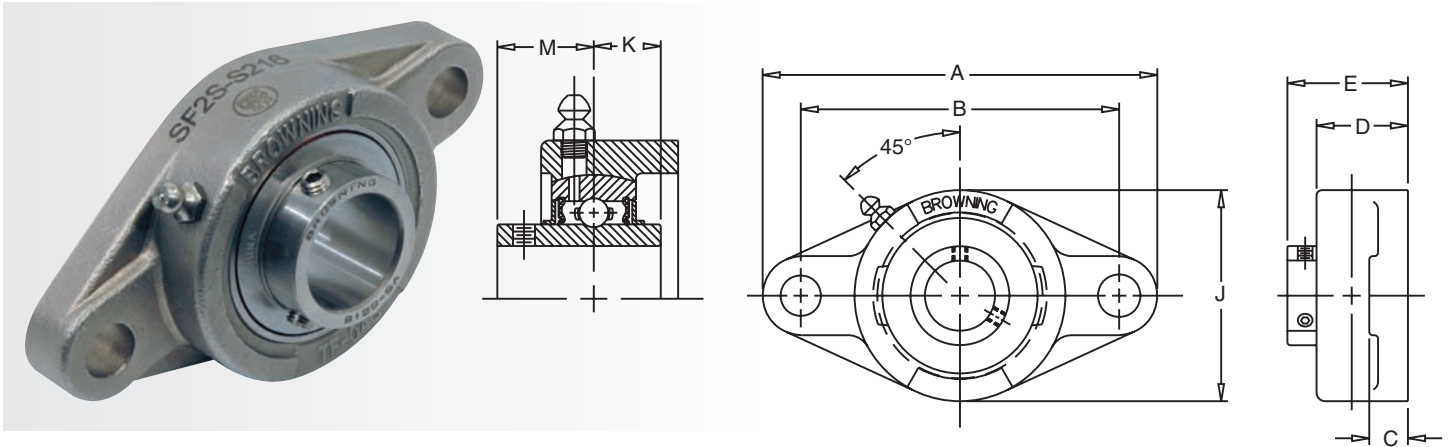

SF2S-S Series 2 Bolt Flange / Stainless Steel Housings

CRES SS Description	Shaft Size	A	B	C	D	E	J	K	M	Bolt Size
SF2S-S212	3/4	4 13/32	3 17/32	7/16	63/64	1 5/16	2 7/16	1/2	23/32	3/8
SF2S-S216	1	4 7/8	3 57/64	33/64	1 3/64	1 13/32	2 11/16	9/16	25/32	3/8
SF2S-S219	1 3/16	5 5/8	4 19/32	33/64	1 3/16	1 37/64	3 9/64	5/8	7/8	1/2
SF2S-S220S	1 1/4	5 5/8	4 19/32	33/64	1 3/16	1 37/64	3 9/64	5/8	7/8	1/2
SF2S-S220	1 1/4	6 5/32	5 1/8	35/64	1 19/64	1 3/4	3 35/64	11/16	1	1/2
SF2S-S223	1 7/16	6 5/32	5 1/8	35/64	1 19/64	1 3/4	3 35/64	11/16	1	1/2
SF2S-S224	1 1/2	6 3/4	5 21/32	35/64	1 27/64	2 1/64	3 15/16	3/4	1 3/16	1/2

BEARINGS

Corrosion Resistant Engineered Solutions



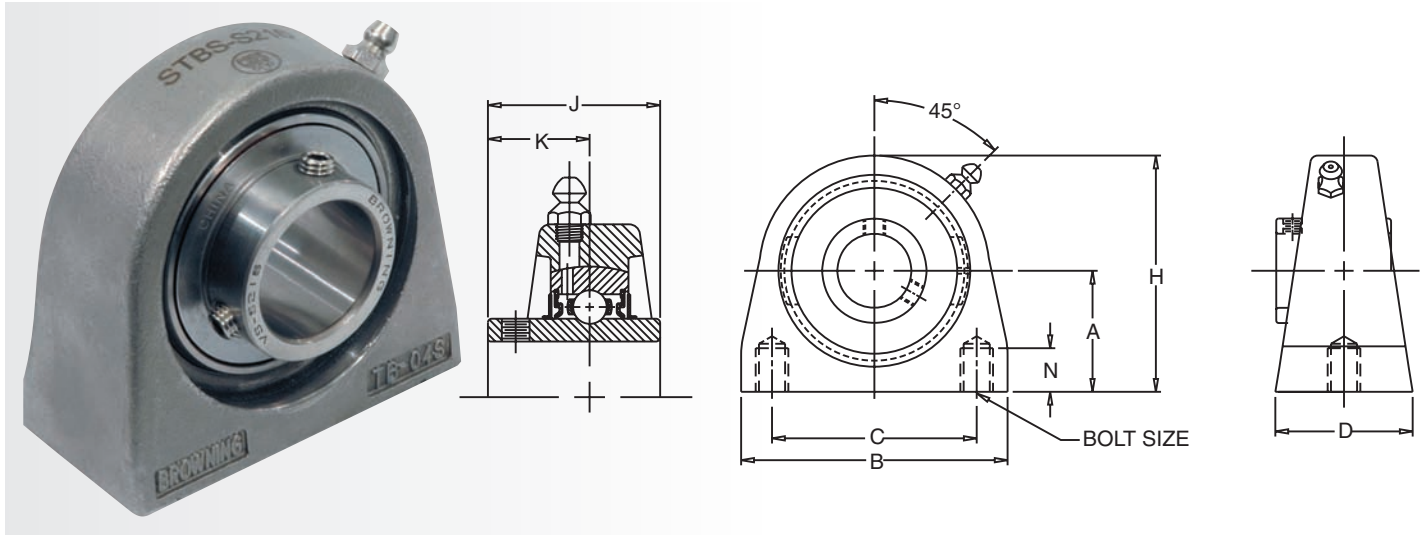

STBS-S Series Tapped Base / Stainless Steel Housings

CRES SS Description	Shaft Size	A	B	C	D	H	J	K	N	Bolt Size
STBS-S212	3/4	1 5/16	2 7/8	2	1 1/2	2 9/16	1 7/32	23/32	1/2	3/8-16
STBS-S216	1	1 7/16	3	2	1 1/2	2 13/16	1 11/32	25/32	1/2	3/8-16
STBS-S219	1 3/16	1 11/16	4	3	1 1/2	3 3/8	1 1/2	7/8	5/8	7/16-14
STBS-S220S	1 1/4	1 11/16	4	3	1 1/2	3 3/8	1 1/2	7/8	5/8	7/16-14
STBS-S220	1 1/4	1 7/8	4 1/4	3 1/4	1 7/8	3 3/4	1 11/16	1	3/4	1/2-13
STBS-S223	1 7/16	1 7/8	4 1/4	3 1/4	1 7/8	3 3/4	1 11/16	1	3/4	1/2-13
STBS-S224	1 1/2	1 15/16	4 5/8	3 1/2	1 7/8	3 15/16	1 15/16	1 3/16	3/4	1/2-13

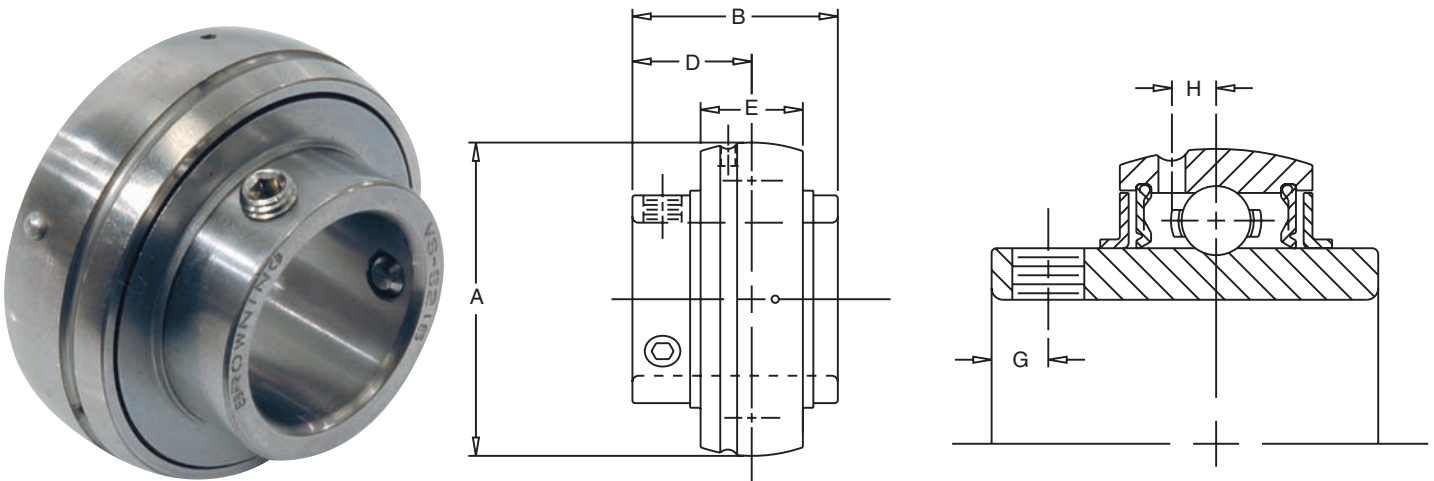

Mounted Ball Bearings

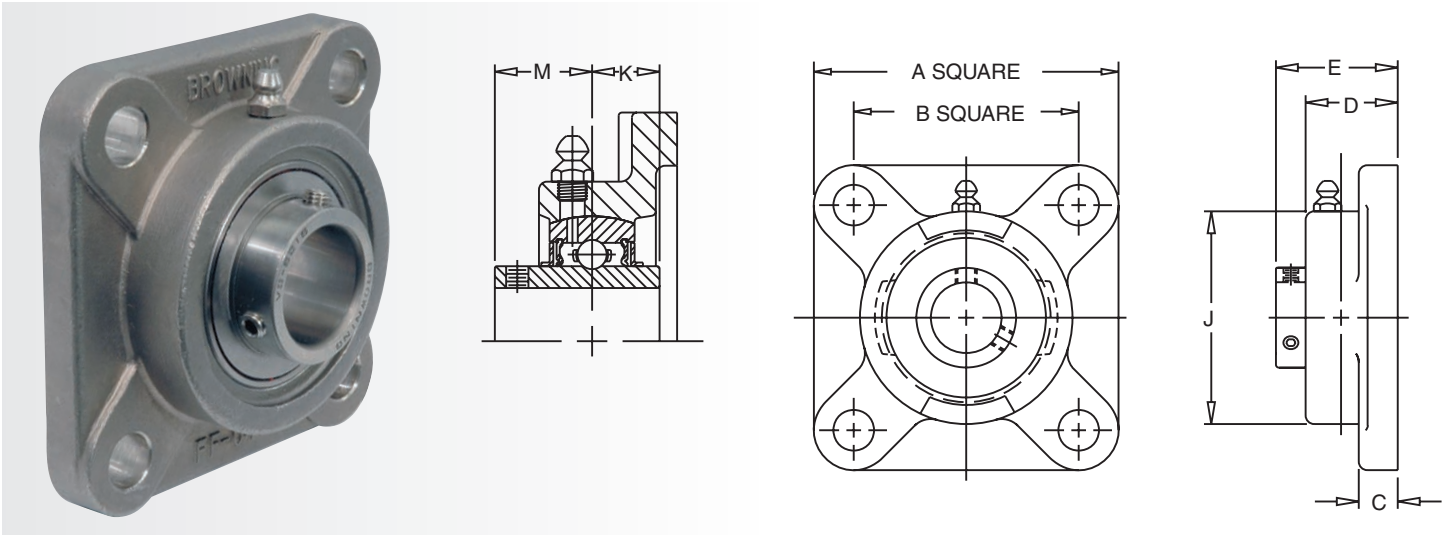

SF4S-S Series 4 Bolt Flange / Stainless Steel Housings

CRES SS Description	Shaft Size	A	B	C	D	E	J	K	M	Bolt Size
SF4S-S212	3/4	3 3/8	2 1/2	7/16	63/64	1 5/16	2 31/64	1/2	23/32	3/8
SF4S-S216	1	3 3/4	2 3/4	33/64	1 3/64	1 13/32	2 43/64	9/16	25/32	3/8
SF4S-S219	1 3/16	4 1/4	3 1/4	33/64	1 3/16	1 37/64	3 5/32	5/8	7/8	1/2
SF4S-S220S	1 1/4	4 1/4	3 1/4	33/64	1 3/16	1 37/64	3 5/32	5/8	7/8	1/2
SF4S-S220	1 1/4	4 5/8	3 5/8	35/64	1 19/64	1 3/4	3 35/64	11/16	1	1/2
SF4S-S223	1 7/16	4 5/8	3 5/8	35/64	1 19/64	1 3/4	3 35/64	11/16	1	1/2
SF4S-S224	1 1/2	5 1/8	4	35/64	1 13/32	2 1/64	3 15/16	3/4	1 3/16	1/2

VS-S Insert

Description	Shaft Size	A	B	D	E	G	H	Interchange	
								AMI	FYH
VS-S212	3/4	1.8504	1 7/32	23/32	5/8	13/64	5/32	MUC 204-12	UC 204-12S6
VS-S216	1	2.0472	1 11/32	25/32	43/64	7/32	5/32	MUC 205-16	UC-205-16S6
VS-S219	1 3/16	2.4409	1 1/2	7/8	3/4	7/32	13/64	MUC 206-19	UC-206-19S6
VS-S220S	1 1/4	2.4409	1 1/2	7/8	3/4	7/32	13/64	MUC 206-20	UC-206-20S6
VS-S220	1 1/4	2.8346	1 11/16	1	25/32	9/32	7/32	MUC-207-20	UC-207-20S6
VS-S223	1 7/16	2.8346	1 11/16	1	25/32	9/32	7/32	MUC-207-23	UC-207-23S6
VS-S224	1 1/2	3.1496	1 15/16	1 3/16	53/64	5/16	15/64	MUC-208-24	UC-208-24S6

The following trade names, trademarks and/or registered trademarks are used in this material by Emerson Power Transmission Corporation for comparison purposes only, are NOT owned by Emerson Power Transmission Corporation and are believed to be owned by the following parties: AMI is a registered trademark of ASAHI Tec Corp. of Japan; FYH is a registered trademark of Nippon Pillow Block Sales Co. LTD of Japan.

BEARINGS

Corrosion Resistant Engineered Solutions



Sealing

With contamination ingress being a leading cause of bearing failure, seals and seal elements are an integral component to the overall performance of a bearing. Over the past seventy years, Sealmaster has stood as the benchmark of sealing design and development. In addition to proven single lip contact seal designs, the new patented High Performance Seal (HPS) offers improved contamination resistance for demanding application conditions.



Sealmaster Single Lip

Sealmaster CR Gold

Sealmaster RPB-CR

Single lip nitrile rubber fabric washer provides good balance of bearing drag, sealing protection and wear resistance.



Sealmaster HPS Triple Lip

Sealmaster PN Gold

Sealmaster CRX-TREME

Triple lip FKM rubber contact seal design provides multi-direction sealing to minimize contamination ingress and retains lubrication. Stainless steel flinger provides a good surface finish and is corrosion resistance to provide an excellent seal contact surface to minimize lip wear. Flinger directs contamination away from bearing, protects rubber lips from direct high-pressure washdown. Grease cavities in seal assembly are factory filled with lubricant for additional contaminant avoidance.



Browning Single Lip (Nitrile)

Browning CRES CZ

Single lip nitrile rubber provides good balance of bearing drag and sealing protection. Zinc coated stamping and flinger help guard against contamination and washdown.



Browning Single Lip (Silicone)

Browning CRES CS

Browning CRES SS

Single lip silicone rubber provides good balance of bearing drag, sealing protection and chemical resistance. Stainless steel stamping and flinger offer additional barriers against contamination and washdown.

Sealing and Accessories

Wet Contamination Performance

Test method: This graphic illustrates the relative performance of rubber contact seals in a slurry contamination test. The bearing is submerged halfway into a sand, salt and water mixture. The bearing rotates while a separate motor stirs the mixture. The test is stopped when the slurry mixture leaks past the seal.

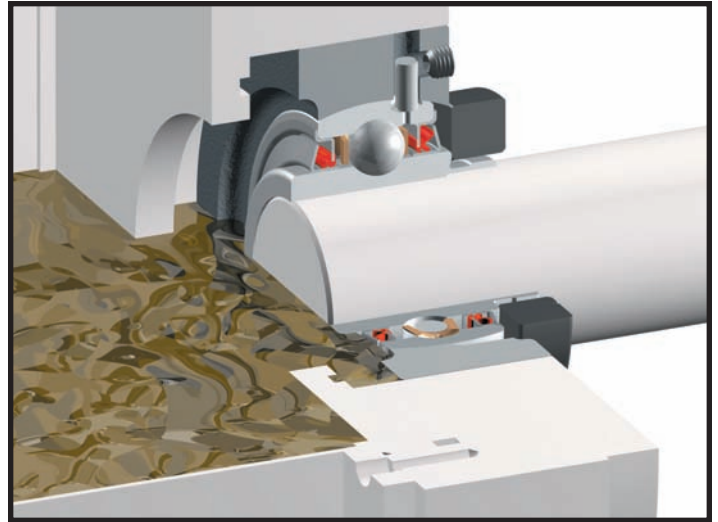

Simulation of Slurry Contamination Test

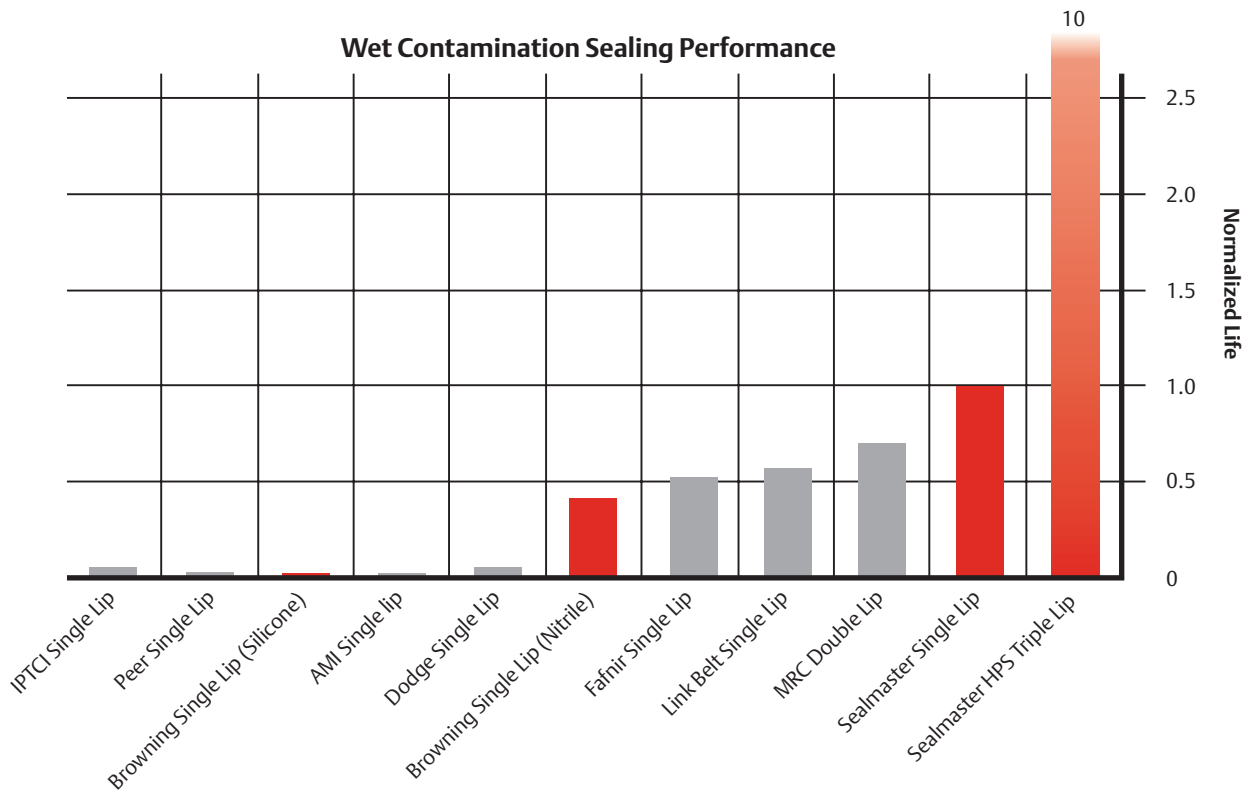

The following trade names, trademarks and/or registered trademarks are used in this material by Emerson Power Transmission Corporation for comparison purposes only, are NOT owned by Emerson Power Transmission Corporation and are believed to be owned by the following parties: AMI is a registered trademark of ASAHI Tec Corp. of Japan; MRC is a registered trademark of SKF USA Inc. ; IPTCI is a registered trademark of A Pual E. Robey Company; Peer is a registered trademark of Peer Bearing Company; Fafnir is a trademark of the Torrington Company; Link Belt is a trademark of Rexnord Corp; Dodge is a trademark of Reliance Electric Company.

BEARINGS

Corrosion Resistant Engineered Solutions



Sealing and Accessories — Mounted Ball Bearings

Additional sealing accessories are available for enhanced bearing protection. End caps offer better protection against high-pressure wash down and can be used to reduce bearing moisture contact. Backside shield gaskets are mounted between the bearing and the equipment frame to reduce moisture runoff. Backside shields are available for two and four bolt flange mounted ball bearings.

End Caps Cap Availability

Product Line	Polymer Snap On	Stainless Bolt On
CRES CS	Y	N/A
CRES CZ	Y	N/A
CRES SS	N/A	N/A
CR GOLD	Y	N/A
PN Gold Stainless	Y	Y*
PN Gold Composite	Y	N/A
CRX-Treme	Y	N/A
Fluropolmer Coated Housings	N/A	N/A

*Note:

This applies to PN Gold mounted ball bearings only. Stainless steel open and closed bolt on end caps available on select 2 bolt and 4 bolt stainless steel housed units – specify B for bolt on cap in nomenclature selection – consult EPT Customer Service for availability.

Example:

1" Shaft Size

- 2 Bolt Flange = CRBFTS-PN16
- 4 Bolt Flange = CRBFS-PN16



Polymer End Caps

- Polypropylene Material: Resistant to corrosion
- Hand Snaps Into Housing: Easy installation
- Shielded Drain Hole: Reduces moisture buildup

Note: Also available in open end design.



Stainless Steel End Caps

- 304 Stainless Steel: Resistant to corrosion and chemical attack
- Bolts onto Housing: Excellent holding power
- Drain Hole: Reduces moisture buildup

Sealing and Accessories

End Cap Part Identification

Shaft Size	Polymer Snap On		Bolt On 2 Bolt		Bolt On 4 Bolt	
	Closed	Open	Closed	Open	Closed	Open
3/4	ECC-12	ECO-12	Not Applicable		Not Applicable	
1	ECC-16	ECO-16	TEC-16	TEO-16	FEC-16	FEO-16
1 3/16	ECC-19	ECO-19	TEC-19	TEO-19	FEC-19	FEO-19
1 1/4R	ECC-19	ECO-20R	TEC-19	TEO-20R	FEC-19	FEO-20R
1 1/4	ECC-23	ECO-20	TEC-23	TEO-20	FEC-23	FEO-20
1 7/16	ECC-23	ECO-23	TEC-23	TEO-23	FEC-23	FEO-23
1 1/2	ECC-24	ECO-24	TEC-24	TEO-24	FEC-24	FEO-24
1 11/16	ECC-27	ECO-27	TEC-27	TEO-27	FEC-27	FEO-27
1 15/16	ECC-31	ECO-31	TEC-31	TEO-31	FEC-31	FEO-31
2 3/16	ECC-35	ECO-35	TEC-35	TEO-35	FEC-35	FEO-35
2 7/16	ECC-39	ECO-39	Not Applicable		Not Applicable	

Backside Shield

- Nitrile Rubber Gaskets: Reduces bearing moisture contact
- 304 Stainless Plate: Improves assembly strength
- Drain Slot: Reduces moisture buildup



Backside Shield Part Identification

Shaft Size	2 Bolt Flange	4 Bolt Flange
3/4	2BSS-12	4BSS-12
1	2BSS-16	4BSS-16
1 3/16	2BSS-19	4BSS-19
1 1/4R	2BSS-20R	4BSS-20R
1 1/4	2BSS-20	4BSS-20
1 7/16	2BSS-23	4BSS-23
1 1/2	2BSS-24	4BSS-24
1 11/16	2BSS-27	4BSS-27
1 15/16	2BSS-31	4BSS-31
2 3/16	2BSS-35	4BSS-35
2 7/16	N/A	4BSS-39

Note: Shields are 0.092" total thickness.
Backside shield not available for Browning CRES SS.

BEARINGS

Corrosion Resistant Engineered Solutions



Stainless Steel Housing Technical Information

Sealmaster Stainless Steel

316 Passivated Stainless Steel:

Highest amount of corrosion resistance currently available for stainless steel bearing housings.

Advanced Casting Technology:

Investment cast process yields a smooth, easy to clean surface.

Solid Construction – Machined Base:

Minimal gaps, no fillings, smooth easy to clean surface.

Specialized Laser Identification:

Permanent brand and nomenclature marking.

Browning Stainless Steel

304 Passivated Stainless Steel:

Good corrosion resistance.

Advanced Casting Technology:

Investment cast process yields a smooth, easy to clean surface.

Solid Construction – Machined Base:

Minimal gaps, no fillings, smooth easy to clean surface.

Specialized Laser Identification:

Permanent brand and nomenclature marking.

Construction and Casting Technology

Sealmaster and Browning housings offer a machined solid base to reduce entrapment points. The investment cast design minimizes excessive pitting and roughness leaving a smooth easy to clean surface. The Sealmaster 316 material offers improved resistance to pitting corrosion. The housings are passivated to enhance the material surface corrosion resistance.



Surface finish of sand-cast vs investment

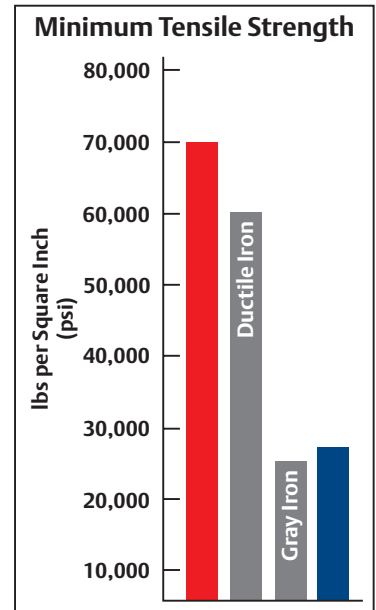

■ Stainless Steel - Sealmaster / Browning
■ Composite - Sealmaster / Browning

Stainless Steel Material Advantage

Stainless steel castings offer higher tensile strength compared to composite housings. The steel material advantage should be considered in application where shock loading, vibration or cycle temperature may be present.



Competitor Unit



CRES Unit

Housing Material

Composite Housing Technical Information

Composite

Nylon 6/6 Fiber Reinforced Composite:	High load capacity
Reinforced Stainless Steel Ferrules:	Increased strength around bolt holes
Solid Construction:	Minimal gaps, no fillings, smooth easy to clean surface
Laser Engraved Identification:	Permanent brand and nomenclature marking

Construction and Material

The high strength composite material has a higher tensile strength than some cast iron housings and offers acceptable load capacity for most applications. The housing does not have any dyes or fillers that would reduce the housing strength. Testing has shown that the Emerson Power Transmission offers the highest strength injection molded composite housing in the market today. Housing offers a machined base and solid stainless steel bolt ferrules allowing fewer places for bacteria to grow.



Competitor Unit



CRES Unit



Competitor Unit



CRES Unit

Laser Engraving (Unit Identification System)

When you buy a product that works, identification is important. Emerson Power Transmission has developed a unique permanent surface marking process and incorporated it on CRES bearing products. No paper or plastic “fly away” stickers. No “disappearing” ink. The brand and part description will be there when it comes time to reorder.

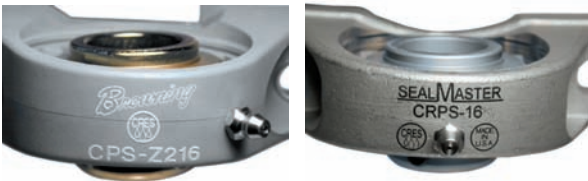

CRES Units

Polymer/Composite Housing Strength 1-7/16” Bore Pillow Block, Radial Load

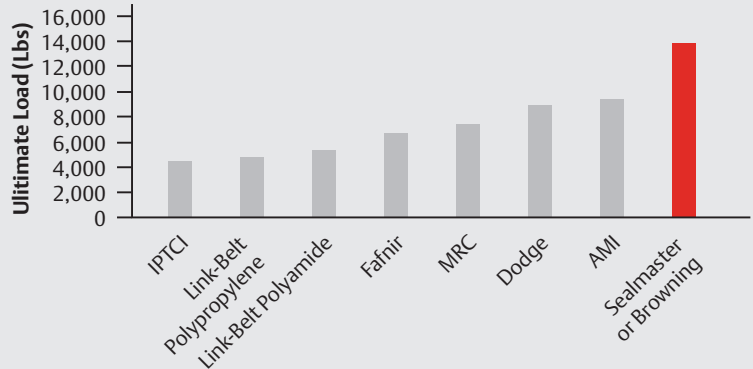

Housing Radial Load Break Test

The bearing housing was mounted to a rigid plate. The bearing insert was pulled through the top of the housing until the housing broke and the load was measured.

*Note, tradenames and trademarks can be found on page 89.

BEARINGS

Corrosion Resistant Engineered Solutions



Sealmaster GoldPlex-FG

GoldPlex food grade grease is suitable for mounted bearing lubrication where incidental contact with food products may occur in any application where clean, routine lubrication is required. The performance advantages include:

- USDA H1 category approved
- Superior corrosion resistance (ASTM D 1743)
- Excellent water washout properties (ASTM D 1264)
- Compatible with major thickeners
- Superior dropping point 572° F (300° C)
- Nonstaining and nontoxic.



GoldPlex-FG vs. Al Complex Mineral Oil **

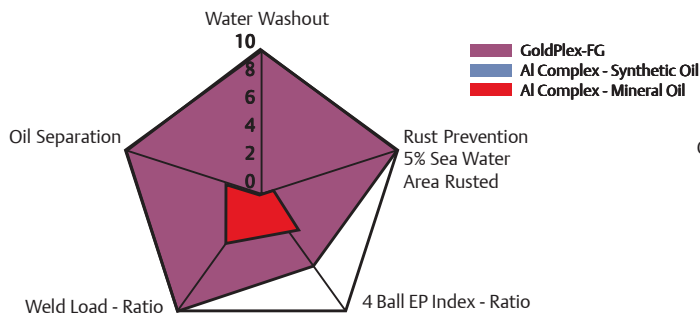

GoldPlex-FG vs. Al Complex Synthetic **

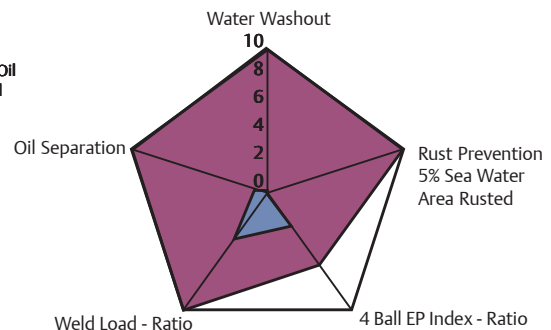

Product Specifications/GoldPlex-FG

Thickener Type	Calcium Sulfonate
Texture	Smooth
Color	White
60-Stroke Penetration, ASTM D 217, 77F	265-295
Dropping Point, ASTM D 2265, F (C)	572 (300)
Oxidation Stability, ASTM D 942, Psi Drop/100	1
Rust and Corrosion Protection, ASTM D 1743	Pass
Modified with 5% Synthetic Seawater	Pass
Water Washout, ASTM D 1264, 175F, %	2.75
Timken* OK Load, ASTM D 2509	65
4-Ball EP, ASTM D 2596 Weld Pt. Kg	620
4-Ball Wear, ASTM D 2266, Scar Dia. Mm, 40 kg	0.45
Oil Separation, ASTM D 1742, Mass %	0.2
Base Oil Viscosity SUS @ 100F	523
Base Oil Viscosity cSt @100C	10.5
Base Oil Viscosity cSt @ 40C	100
NLGI #	2
Operating Temperature Range	-40F to 350F

Sealmaster GoldPlex – SPL High Performance Lubricators

Single point lubricators are designed to automatically lubricate your bearings, which in turn can reduce your overall maintenance costs.



GoldPlex-SPL (V) is used in single bearing direct or remote applications for automatic bearing relubrication. Performance advantages include:

- Variable control pad is easy to use for adjusting lubricant dispensing amounts. There is no need to use and stock a series of activator keys or rubber control rings.
- The 250cc grease capacity allows for extended replacement intervals.
- Purge function can be used when back pressure exists or when the lube is clogged.
- Factory filled with Sealmaster GoldPlex-HP grease (available with food grade Sealmaster GoldPlex-FG grease).

GoldPlex-SPL (EM) is used with a single bearing or up to eight bearings when utilizing a distribution block. Service kits are available which include a grease pouch and new batteries. Performance advantages include:

- Variable control pad is easy to use for adjusting lubricant dispensing amounts. There is no need to use and stock a series of activator keys or rubber control rings.
- 125cc or 250cc grease capacity sized to match your specific lubrication needs.
- Purge function can be used when back pressure exists or when the lube is clogged.
- Clear plastic cover protects the variable control pad from corrosion.
- Factory filled with Sealmaster GoldPlex-HP grease (available with food grade Sealmaster GoldPlex-FG grease).



For more information please refer to Sealmaster brochure PPP-04 or call 1-800-626-2120

BEARINGS

Corrosion Resistant Engineered Solutions



This chart displays load capacity in pounds for a given L10 life, speed and shaft size. The shaded areas indicate the maximum speed ratings for CR Gold only. The values in the table represent loads at ideal conditions with press fit mounting to the shaft. ABMA recommends applying life adjustments factors for slip fit mounted ball bearings and when using alternative race materials. To obtain de-rated load, divide load in the table by 1.29 (1.36 for CRX-TREME). The values in the table represent equivalent radial loads only. For combined radial and thrust load, the equivalent radial load must be calculated before applying the load in the table.

Load Ratings for Sealmaster CR Gold, PN Gold and CRX-TREME

Shaft Size	BDR	L10 hrs	RPM													
			50	150	250	500	750	1000	1250	1500	1750	2000	3000	4000	5000	6000
1/2 5/8 3/4	2611	5000	653	653	619	491	429	390	362	341	324	310	270	246	228	215
		10000	653	583	491	390	341	310	287	270	257	246	215	195	181	170
		30000	583	404	341	270	236	215	199	188	178	170	149	135	126	118
		50000	491	341	287	228	199	181	168	158	150	144	126	114	106	100
		100000	390	270	228	181	158	144	133	126	119	114	100	91	84	79
1	2801	5000	700	700	664	527	461	418	388	366	347	332	290	264	245	230
		10000	700	625	527	418	366	332	308	290	276	264	230	209	194	183
		30000	625	433	366	290	253	230	214	201	191	183	160	145	135	127
		50000	527	366	308	245	214	194	180	170	161	154	135	122	114	107
		100000	418	290	245	194	170	154	143	135	128	122	107	97	90	85
1 3/16 1 1/4R	4381	5000	1095	1095	1039	825	720	654	608	572	543	519	454	412	383	
		10000	1095	978	825	654	572	519	482	454	431	412	360	327	304	
		30000	978	678	572	454	396	360	334	315	299	286	250	227	211	
		50000	825	572	482	383	334	304	282	265	252	241	211	191	178	
		100000	654	454	383	304	265	241	224	211	200	191	167	152	141	
1 1/4 1 3/8 1 7/16	5782	5000	1446	1446	1371	1088	951	864	802	755	717	686	599	544		
		10000	1446	1290	1088	864	755	686	636	599	569	544	475	432		
		30000	1290	895	755	599	523	475	441	415	394	377	330	299		
		50000	1088	755	636	505	441	401	372	350	333	318	278	253		
		100000	864	599	505	401	350	318	295	278	264	253	221	200		
1 1/2	7340	5000	1835	1835	1741	1381	1207	1096	1018	958	910	870	760	691		
		10000	1835	1638	1381	1096	958	870	808	760	722	691	603	548		
		30000	1638	1136	958	760	664	603	560	527	501	479	418	380		
		50000	1381	958	808	641	560	509	472	445	422	404	353	321		
		100000	1096	760	641	509	445	404	375	353	335	321	280	254		
1 5/8 1 11/16 1 3/4	7901	5000	1975	1975	1874	1487	1299	1180	1096	1031	979	937	818			
		10000	1975	1763	1487	1180	1031	937	870	818	777	744	650			
		30000	1763	1222	1031	818	715	650	603	567	539	516	450			
		50000	1487	1031	870	690	603	548	509	479	455	435	380			
		100000	1180	818	690	548	479	435	404	380	361	345	301			
1 15/16 2R	7889	5000	1972	1972	1871	1485	1297	1178	1094	1029	978	935	817			
		10000	1972	1760	1485	1178	1029	935	868	817	776	742	649			
		30000	1760	1221	1029	817	714	649	602	567	538	515	450			
		50000	1485	1029	868	689	602	547	508	478	454	434	379			
		100000	1178	817	689	547	478	434	403	379	360	345	301			
2 2 3/16	9752	5000	2438	2438	2312	1835	1603	1457	1352	1273	1209	1156	1010			
		10000	2438	2176	1835	1457	1273	1156	1073	1010	959	918	802			
		30000	2176	1509	1273	1010	882	802	744	700	665	636	556			
		50000	1835	1273	1073	852	744	676	628	591	561	537	469			
		100000	1457	1010	852	676	591	537	498	469	445	426	372			
2 1/4 2 7/16	11789	5000	2947	2947	2795	2219	1938	1761	1635	1538	1461	1398				
		10000	2947	2631	2219	1761	1538	1398	1298	1221	1160	1109				
		30000	2631	1824	1538	1221	1067	969	900	847	804	769				
		50000	2219	1538	1298	1030	900	817	759	714	678	649				
		100000	1761	1221	1030	817	714	649	602	567	538	515				

Notes:

- Not all shaft sizes are available for each product line; refer to the product pages to determine availability.
- Typical operating temperature range of CR Gold, PN Gold and CRX-TREME bearings are -20° F to 200° F (0° F to 150° F for composite housings).
- For loads, speeds and temperature not listed, contact Application Engineering at 219-465-2211.

Speed and Load Charts

This chart displays load capacity in pounds for a given L10 life, speed and shaft size. The values in the table represent loads at ideal conditions with press fit mounting to the shaft. ABMA recommends applying life adjustments factors for slip fit mounted ball bearings and when using alternative race materials. To obtain de-rated load, divide load in the table by 1.29 (1.36 for CRES CS and CRES SS). The values in the table represent equivalent radial loads only. For combined radial and thrust load, the equivalent radial load must be calculated before applying the load in the table.

Load Ratings for Browning CRES CZ

Shaft Size	BDR	L10 hrs	RPM													
			50	150	250	500	750	1000	1250	1500	1750	2000	3000	4000	5000	6000
3/4	2611	5000	653	653	619	491	429	390	362	341	324	310	270	246	228	215
		10000	653	583	491	390	341	310	287	270	257	246	215	195	181	170
		30000	583	404	341	270	236	215	199	188	178	170	149	135	126	118
		50000	491	341	287	228	199	181	168	158	150	144	126	114	106	100
		100000	390	270	228	181	158	144	133	126	119	114	100	91	84	79
1	2801	5000	700	700	664	527	461	418	388	366	347	332	290	264	245	
		10000	700	625	527	418	366	332	308	290	276	264	230	209	194	
		30000	625	433	366	290	253	230	214	201	191	183	160	145	135	
		50000	527	366	308	245	214	194	180	170	161	154	135	122	114	
		100000	418	290	245	194	170	154	143	135	128	122	107	97	90	
1 3/16 1 1/4S	4381	5000	1095	1095	1039	825	720	654	608	572	543	519	454	412		
		10000	1095	978	825	654	572	519	482	454	431	412	360	327		
		30000	978	678	572	454	396	360	334	315	299	286	250	227		
		50000	825	572	482	383	334	304	282	265	252	241	211	191		
		100000	654	454	383	304	265	241	224	211	200	191	167	152		
1 1/4 1 3/8 1 7/16	5782	5000	1446	1446	1371	1088	951	864	802	755	717	686	599	544		
		10000	1446	1290	1088	864	755	686	636	599	569	544	475	432		
		30000	1290	895	755	599	523	475	441	415	394	377	330	299		
		50000	1088	755	636	505	441	401	372	350	333	318	278	253		
		100000	864	599	505	401	350	318	295	278	264	253	221	200		
1 1/2	7340	5000	1835	1835	1741	1381	1207	1096	1018	958	910	870	760			
		10000	1835	1638	1381	1096	958	870	808	760	722	691	603			
		30000	1638	1136	958	760	664	603	560	527	501	479	418			
		50000	1381	958	808	641	560	509	472	445	422	404	353			
		100000	1096	760	641	509	445	404	375	353	335	321	280			

Load Ratings for Browning CRES CS and CRES SS

Shaft Size	BDR	L10 hrs	RPM									
			50	150	250	500	750	1000	1250	1500	1750	2000
3/4	2888	5000	722	722	685	544	475	431	400	377	358	342
		10000	722	644	544	431	377	342	318	299	284	272
		30000	644	447	377	299	261	237	220	207	197	188
		50000	544	377	318	252	220	200	186	175	166	159
		100000	431	299	252	200	175	159	148	139	132	126
1	3156	5000	789	789	748	594	519	471	438	412	391	374
		10000	789	704	594	471	412	374	347	327	311	297
		30000	704	488	412	327	286	259	241	227	215	206
		50000	594	412	347	276	241	219	203	191	182	174
		100000	471	327	276	219	191	174	161	152	144	138
1 3/16 1 1/4S	4381	5000	1095	1095	1039	825	720	654	608	572	543	519
		10000	1095	978	825	654	572	519	482	454	431	412
		30000	978	678	572	454	396	360	334	315	299	286
		50000	825	572	482	383	334	304	282	265	252	241
		100000	654	454	383	304	265	241	224	211	200	191
1 1/4 1 3/8 1 7/16	5782	5000	1446	1446	1371	1088	951	864	802	755	717	
		10000	1446	1290	1088	864	755	686	636	599	569	
		30000	1290	895	755	599	523	475	441	415	394	
		50000	1088	755	636	505	441	401	372	350	333	
		100000	864	599	505	401	350	318	295	278	264	
1 1/2	6639	5000	1660	1660	1574	1250	1092	992	921	866		
		10000	1660	1481	1250	992	866	787	731	688		
		30000	1481	1027	866	688	601	546	507	477		
		50000	1250	866	731	580	507	460	427	402		
		100000	992	688	580	460	402	365	339	319		

Notes:

- Typical operating temperature range of CRES SS is 0° F to 200° F.
- Typical operating temperature range of CRES CZ and CRES CS is 0° to 150° F.
- For loads, speeds and temperatures not listed, contact Application Engineering at 219-465-2211.

BEARINGS

Corrosion Resistant Engineered Solutions



This chart displays load capacity in pounds for a given L10 life, speed and shaft size. The values in the table represent equivalent radial loads only. For combined radial and thrust load, the equivalent radial load must be calculated before applying the load in the table.

Load Ratings for Sealmaster RPB-CR

Shaft Size	BDR	L10 hrs	RPM													
			50	150	250	500	750	1000	1250	1500	1750	2000	2500	3000	3500	4000
1 3/16 1 1/4	2975	5000	2975	2975	2975	2552	2260	2073	1939	1836	1753	1684	1575	1491	1424	1368
		10000	2975	2975	2552	2073	1836	1684	1575	1491	1424	1368	1279	1211	1156	1111
		30000	2975	2140	1836	1491	1320	1211	1133	1072	1024	984	920	871	832	799
		50000	2552	1836	1575	1279	1133	1039	972	920	878	844	789	747	714	685
		100000	2073	1491	1279	1039	920	844	789	747	714	685	641	607	580	557
1 3/8 1 7/16	4760	5000	4760	4760	4760	4084	3616	3317	3102	2937	2804	2694	2520	2386	2278	
		10000	4760	4760	4084	3317	2937	2694	2520	2386	2278	2188	2047	1938	1850	
		30000	4760	3424	2937	2386	2112	1938	1812	1716	1638	1574	1472	1394	1331	
		50000	4084	2937	2520	2047	1812	1662	1555	1472	1406	1350	1263	1196	1142	
		100000	3317	2386	2047	1662	1472	1350	1263	1196	1142	1097	1026	971	927	
1 1/2 1 5/8 1 11/16	6140	5000	6140	6140	6140	5268	4664	4279	4002	3789	3617	3475	3250	3077		
		10000	6140	6140	5268	4279	3789	3475	3250	3077	2938	2823	2640	2500		
		30000	6140	4416	3789	3077	2725	2500	2338	2213	2113	2030	1899	1798		
		50000	5268	3789	3250	2640	2338	2144	2006	1899	1813	1742	1629	1542		
		100000	4279	3077	2640	2144	1899	1742	1629	1542	1473	1415	1323	1253		
1 3/4 1 15/16 2	8070	5000	8070	8070	8070	6923	6130	5624	5259	4979	4754	4568	4272			
		10000	8070	8070	6923	5624	4979	4568	4272	4045	3862	3710	3470			
		30000	8070	5804	4979	4045	3581	3285	3072	2909	2777	2668	2496			
		50000	6923	4979	4272	3470	3072	2818	2636	2496	2383	2289	2141			
		100000	5624	4045	3470	2818	2496	2289	2141	2027	1935	1859	1739			
2 3/16	8570	5000	8570	8570	8570	7352	6510	5972	5585	5288	5049	4851	4537			
		10000	8570	8570	7352	5972	5288	4851	4537	4295	4101	3940	3685			
		30000	8570	6164	5288	4295	3803	3489	3263	3089	2950	2834	2650			
		50000	7352	5288	4537	3685	3263	2993	2799	2650	2530	2431	2274			
		100000	5972	4295	3685	2993	2650	2431	2274	2153	2055	1975	1847			
2 1/4 2 7/16 2 1/2	9030	5000	9030	9030	9030	7747	6860	6293	5885	5572	5320	5111				
		10000	9030	9030	7747	6293	5572	5111	4780	4526	4321	4152				
		30000	9030	6495	5572	4526	4007	3676	3438	3255	3108	2986				
		50000	7747	5572	4780	3883	3438	3154	2950	2793	2666	2562				
		100000	6293	4526	3883	3154	2793	2562	2396	2268	2166	2081				
2 11/16 2 3/4 2 15/16 3	9630	5000	9630	9630	9630	8262	7316	6711	6276	5942	5674	5408				
		10000	9630	9630	8262	6711	5942	5451	5098	4826	4608					
		30000	9630	6926	5942	4826	4274	3920	3666	3471	3314					
		50000	8262	5942	5098	4141	3666	3363	3145	2978	2843					
		100000	6711	4826	4141	3363	2978	2732	2555	2419	2310					
3 3/16 3 7/16 3 1/2	15320	5000	15320	15320	15320	13143	11638	10676	9984	9453	9084	8778				
		10000	15320	15320	13143	10676	9453	8671	8110	7678						
		30000	15320	11018	9453	7678	6799	6237	5833	5522						
		50000	13143	9453	8110	6587	5833	5351	5004	4738						
		100000	10676	7678	6587	5351	4738	4346	4065	3848						
3 15/16 4	20980	5000	20980	20980	20980	17999	15938	14620	13673							
		10000	20980	20980	17999	14620	12945	11875	11106							
		30000	20980	15089	12945	10515	9311	8541	7988							
		50000	17999	12945	11106	9021	7988	7327	6853							
		100000	14620	10515	9021	7327	6488	5952	5566							
4 7/16 4 1/2	25750	5000	25750	25750	25750	22091	19561	17944	16782							
		10000	25750	25750	22091	17944	15889	14575	13631							
		30000	25750	18520	15889	12906	11427	10483	9804							
		50000	22091	15889	13631	11072	9804	8993	8411							
		100000	17944	12906	11072	8993	7963	7305	6832							
4 15/16 5	35520	5000	35520	35520	35520	30473	26983	24752								
		10000	35520	35520	30473	24752	21917	20105								
		30000	35520	25547	21917	17802	15763	14460								
		50000	30473	21917	17802	15273	13524	12405								
		100000	24752	17802	15273	12405	10985	10076								

Notes:

- Typical operating temperature ranges for standard bearings are -20° F to 200° F.
- For loads, speeds outside the rating chart, contact Application Engineering at 219-465-2211.

A Focus on Customer Service

From initial design to production and installation, Emerson Power Transmission creates the finest mounted bearings by paying attention to detail across the entire product creation life cycle. If you have an application that requires special design considerations or have additional technical requirements, contact Emerson Power Transmission Bearing Technical Customer Service at 219-465-2211. Additional information available for:

- Chemical resistance
- Installation and maintenance instructions
- Load ratings
- Interchange information
- Component dimensional specification
 - * Grease fitting
 - * Set screw size
 - * Misalignment capabilities

For ordering information, contact your authorized distributor or Emerson Power Transmission Customer Service at:

Emerson Power Transmission

Telephone: 1-800-626-2120

Fax: 1-800-262-3292

For additional information contact Mounted Bearing Technical Service at 219-465-2211 or email Application Engineers at sealmaster.engineering@emerson-ept.com.

BEARINGS

Corrosion Resistant Engineered Solutions



CRES Gearing

Emerson Power Transmission CRES line of gearing products are designed for use in demanding conditions found in washdown environments. Emerson Power Transmission's enclosed gear offerings include: Morse stainless steel worm gear reducers and a comprehensive line of helical reducer configurations available with two washdown protective coatings.



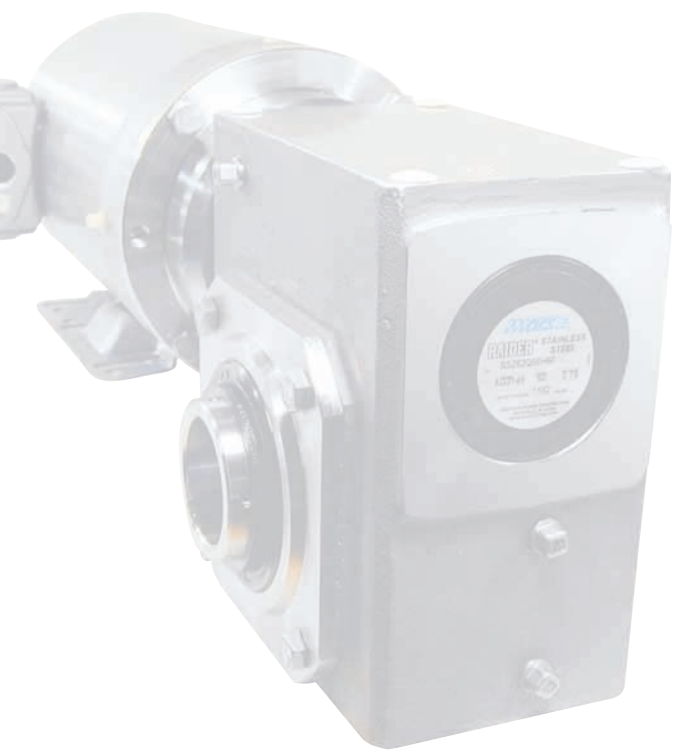

Gearing Products

Morse Stainless Steel Raider® Plus

Worm Gear Reducers 102-119

Features and Benefits 102-103

Ordering and Part Number Configuration 104-105

Selection Procedures 106-107

AGMA Application Classification 108-109

Dimensional Data 110-113

Accessories 114-115

Engineering 116-119

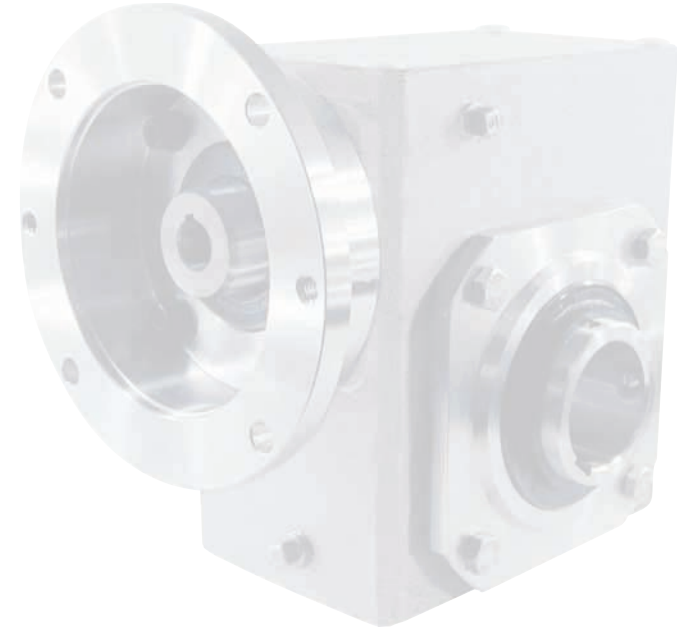

Expanded, Corrosion-Resistant Coatings

For Browning Helical Reducers and Gearmotors

Corro-Duty Gray and Corro-Duty White 120-121

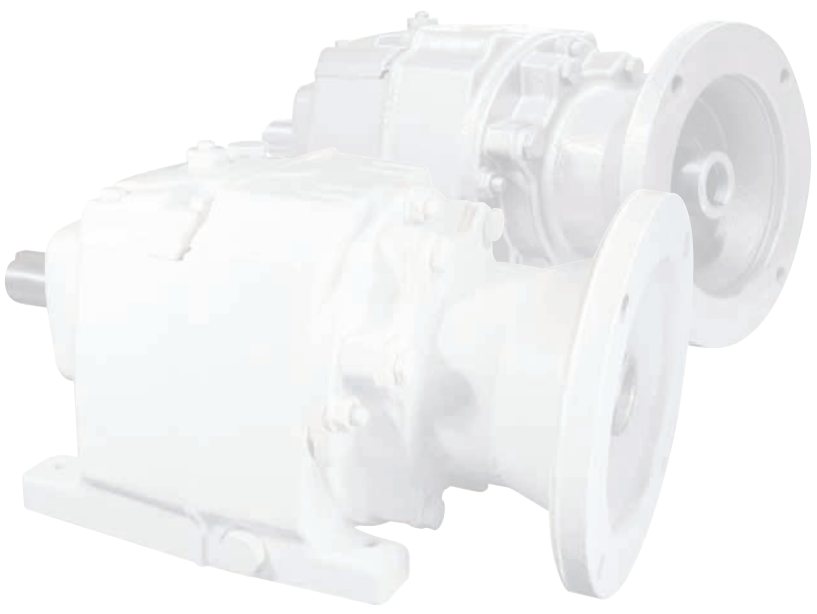

GEARING

Corrosion Resistant Engineered Solutions



CRES RAIDER Plus *Stainless Steel Worm Gear Reducers*

Designed for use in washdown environments, Morse stainless steel Raider Plus worm gear reducers include state-of-the-art features built into every gear reducer. A non-metallic quill liner, an auxiliary v-ring seal on the output and food grade oil helps this gear reducer operate in a variety of corrosive applications.

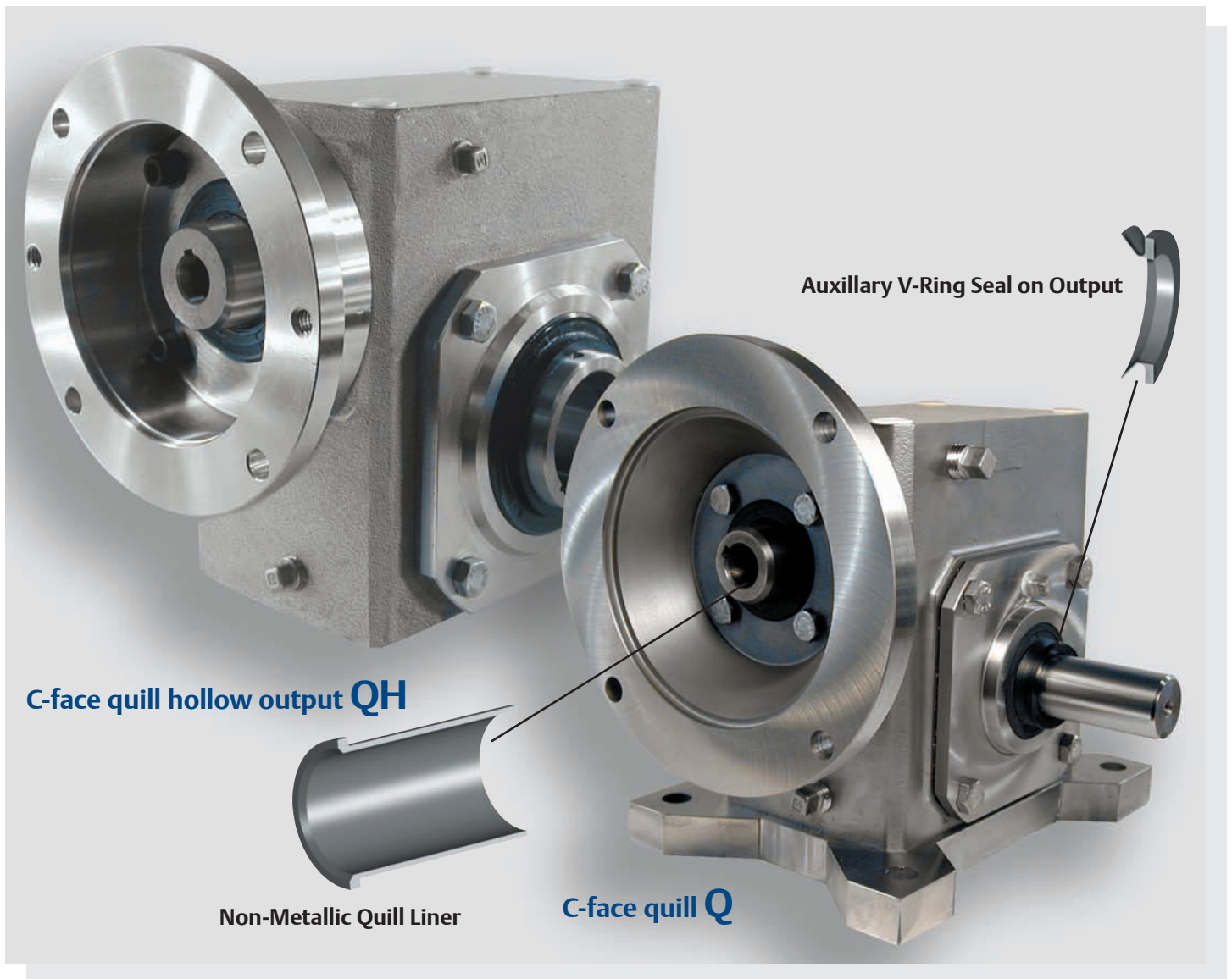

CRES Stainless Steel Raider Plus

Components Material

Housing

- Stainless Steel

Stainless Steel Accessories

- Torque Arm Kit
- Adjustable Torque Arm Kit
- Bushings
- Solid Base Kit

Features and Benefits

Premium 316 Stainless Steel Housing:

316 stainless is more resistant than 304 to pitting caused by bleach washdown.

Stainless Steel Shaft Hardware and Accessories:

Provide the ultimate in corrosion resistance – stainless hollow and solid output shafts available.

Non-Metallic Quill Liner:

Eliminates fretting and allows for easier motor removal.

Bearing Supported Quill Input:

Eliminates shaft wobble and increases seal life.

Dual Encapsulated Seals:

Helps keep contaminants out and lubricant in.

Stainless Steel Normally Closed Breather:

Minimizes pressure build-up and excludes contaminants.

Auxillary V-Ring Seal on Output:

Provides added protection from impurities entering the reducer.

USDA/FDA Compliant Food Grade Oil:

Provides lubrication satisfactory for food processing applications.

Stainless Steel Accessories

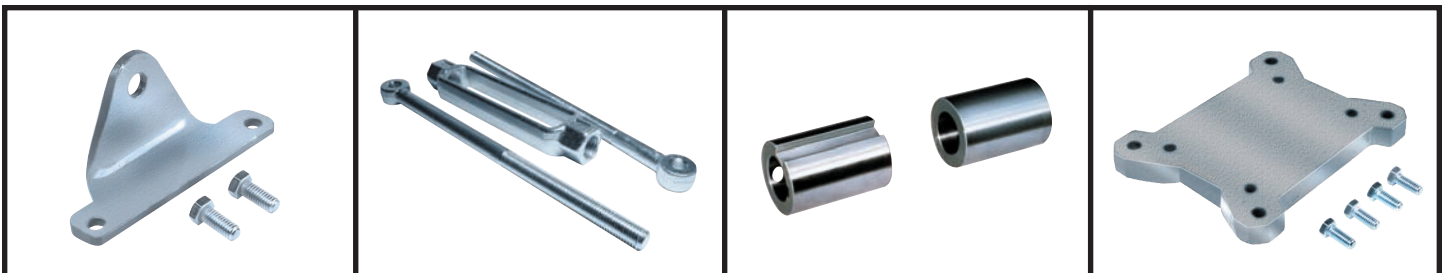

Torque Arm Kit

Adjustable Torque Arm Kit

Bushings

Solid Base Kit

Motors and accessories sold separately.

GEARING

Corrosion Resistant Engineered Solutions



How to Order

The Morse Worm Gear Speed Reducer can easily be sized and ordered by following these instructions.

Basic Unit and Components

This method of ordering is used when versatility and modularity are desired. It is especially convenient for distributors and customers that want to stock the various basic units and components, so that an almost unlimited number of configurations can be put together. When ordering by this method, the basic unit and components will not be assembled, but will be shipped in separate cartons.

Ordering Steps:

1. Find the desired style to be ordered on pages 110 through 113 in this catalog.
2. Go to the dimension table for the specific style desired and find the “Components” section. The basic unit and component part numbers are shaded for easy reference.
3. Complete the basic unit part number by following the foot note instructions.
4. Order the complete basic unit part number along with the indicated component part numbers that will make up the desired SS Raider Plus style.

Example:

A QT Style, 145TC NEMA frame, 30: Ratio, 2.62" C.D., with left output shaft. A standard base kit is also required.

Steps:

1. Go to pages 110 and 111 where style QT will be found.
2. Style Q on page 111 shows basic unit numbers and dimensions. Style QT shows components and dimensions for G-Face Quilled Worm Top.
3. Find the unit size needed which is 262Q140, then complete the Basic Unit part number by adding shaft assembly and ratio symbol to unit size – **SS262Q140L30**.
4. Basic unit part number and component part numbers required are:

Reducer: **SS262Q140L30**
Base Kit: **SS262S-BK**

CRES Stainless Steel Raider Plus

Part Description Configuration

Stainless Steel	Center Distance	Type of Input	Output Shaft Arrangement	Ratio
SS	175	Q	LR	30
	1.75"=175	Q = C Face Quilled	L = Left Output	5
	2.06"=206		R = Right Output	10
	2.62"=262		LR = Left & Right Output	15
			H = Hollow Output	20
				25
				30
				40
				50
				60

It is recommended to use the above chart to arrive at the Stainless Steel Raider Plus reducer part description. The above sample part description is SS175Q56LR30. This description does NOT include feet or other available mounting accessories that are available for the SS Raider Plus product. These accessories are sold separately using the part descriptions for the appropriate product. Not all ratios are available in each configuration.

Raider units ordered with Hollow Outputs have a stock bore for each C.D. (Bushing kits are available to help reducers fit on shafts that are smaller than the stock bore.)

Accessory Descriptions

Bushing Kits

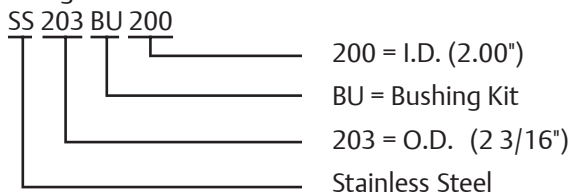

Solid Base Kit

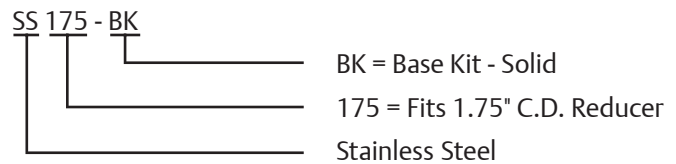

Torque Arm Kit

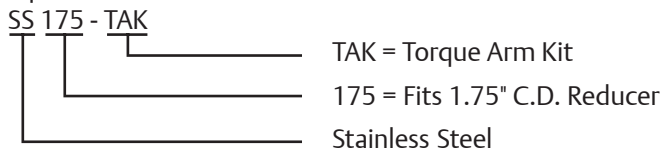

Adjustable Torque Arm Kit

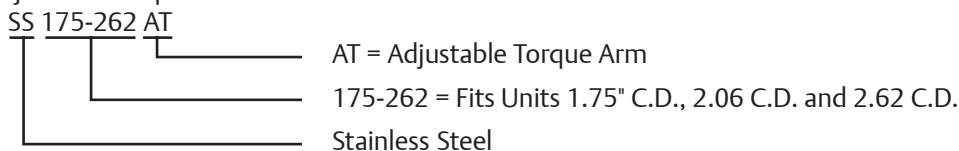

GEARING

Corrosion Resistant Engineered Solutions





Selection Procedure of Stainless Worm Gear Speed Reducers

1. DETERMINE SERVICE FACTOR

From service factor table no. A-1 determine service factor for the application.

2. DETERMINE THE OVERALL DRIVE RATIO

$$\text{Overall Drive Ratio} = \frac{\text{RPM of driver}}{\text{RPM of driven}}$$

When overall drive ratio is not one of the stock speed reducer ratios shown in tables on pages 110 through 113, a chain, belt, or gear drive with further reduction for the output side will be necessary.

3. DETERMINE EQUIVALENT HP

$$\text{Equivalent HP} = \text{Actual Motor HP} \times \text{Service Factor (Step \# 1)}$$

4. DETERMINE THE SIZE OF SPEED REDUCER REQUIRED

Refer to page 107 and select a speed reducer having a mechanical input horsepower equal to or slightly greater than the equivalent HP calculated in Step No. 3 above or use the pre-selection tables on pages 117-119.

5. CHECK THE OVERHUNG LOAD AND THRUST LOADS

Calculate the overhung load for drives to be mounted directly on the reducer shafts by following instructions on this page. Check this and any existing thrust loads against the load values shown on pages 107 and 117 through 119, and if the calculated load is greater than the values in the table, select a larger speed reducer.

NOTE: Refer combined overhung and thrust loads to the Emerson Power Transmission Technical Services.

EXAMPLE NO. 1

Select a worm gear speed reducer for a conveyor in a bakery. The speed reducer will be driven by a 1.0 HP, 1750 RPM, 56 Frame, C-Face Motor. The left reducer output shaft will be directly coupled to the mixer shaft. The conveyor will operate 8 - 10 hours daily and the shaft speed is 58 RPM. The reducer also requires a horizontal mounting base with the worm on top. The conveyor is uniformly fed.

1. DETERMINE THE SERVICE FACTOR

From table no. A-1 note that the service factor for a conveyor operating 3 - 10 hours per day is 1.0.

2. DETERMINE OVERALL DRIVE RATIO

$$\text{Overall Drive Ratio} = \frac{\text{RPM OF DRIVER}}{\text{RPM OF DRIVEN}} = \frac{1750}{58} = 30.17$$

Since there is not an auxiliary output drive required, the reducer ratio needed is 30:1.

3. DETERMINE EQUIVALENT HORSEPOWER

$$\begin{aligned} &\text{Multiply Motor HP} \times \text{Service Factor} \\ &1.0 \times 1.0 = 1.0 \text{ Equivalent HP} \end{aligned}$$

4. DETERMINE THE SIZE OF SPEED REDUCER REQUIRED

From page 107 under 1750 RPM Driver - 30:1 Ratio - 58 RPM Output, and under "Input HP" find the rating equal to or greater than the 2 HP given in the example. Note that a 262 reducer has a rating of 1.48 HP. The correct part numbers required are:

Reducer: **SS262Q56L30**
Base Kit: **SS262S-BK**

Alternate Method

From page 117 under 1750 RPM Driver - 30:1 Ratio, 58.3 R.P.M. Output, select a reducer part number SS262Q56 and motor part number WDP1S2AFCR. Again, the correct part numbers required are:

Reducer: **SS262Q56L30**
Base Kit: **SS262S-BK**

5. DETERMINE THE MOTOR HORSEPOWER

The motor horsepower is already known to be 1.0 HP. From page 116, select the 1 HP 56C frame motor. The correct part number for the motor is:

WDP1S2AFCR

6. CHECK OVERHUNG LOAD AND THRUST LOADS

The unit will be coupling connected on the output shaft. Overhung load does not need to be calculated. There is not any thrust on the output shaft. There is neither thrust nor overhung load on the input shaft because it is mated with a C-Face motor. Therefore, the reducer selected is the proper size.

OVERHUNG LOADS

When a speed reducer is driven by any belt, chain or gear drive, or when the speed reducer drives a driven unit through a belt, chain or gear drive, overhung loads must not exceed those shown on page 107. Use the following formula to calculate the overhung loads:

$$OL = \frac{2TK}{D}$$

where	OL	=	Overhung Load
	T	=	Actual Shaft Torque (inch-pounds)
	D	=	P. D. of Sprocket, Sheave, Pulley or Gear
	K	=	1.0 for Chain Drive
		=	1.25 for Gear Drive
		=	1.25 for Gearbelt Drive
		=	1.50 for V-Belt Drive
		=	2.50 for Flat Belt Drive

No overhung loads are encountered when the speed reducer is coupling connected to the driver and/or driven machine. However, care should be taken in aligning the shafts to avoid pre-loading bearings in misalignment.

CRES Stainless Steel Raider Plus

Input Horsepower, Output Torque, Overhung Load and Thrust Load for Stainless Steel Raider Plus Single Reduction Worm Gear Reducers

UNIT SIZE ■	MECHANICAL		THERMAL		MAXIMUM OVERHUNG LOAD Lbs.	MAX. THRUST LOAD Lbs.
	Input HP	Output Torque	Input HP	Output Torque		
1750 RPM DRIVER-5:1 RATIO-350 RPM OUTPUT						
175	2.13	352	1.74	288	663	868
206	3.04	510	2.44	409	913	1265
262	5.38	909	4.07	687	1295	1596
1750 RPM DRIVER-10:1 RATIO-175 RPM OUTPUT						
175	1.32	429	1.23	399	740	1098
206	1.95	636	1.74	568	1078	1580
262	3.54	1163	3.02	994	1295	1976
1750 RPM DRIVER-15:1 RATIO-116.6 RPM OUTPUT						
175	0.99	462	0.96	449	740	1253
206	1.43	680	1.28	607	1078	1820
262	2.61	1252	2.17	1041	1295	2296
1750 RPM DRIVER-20:1 RATIO-87.5 RPM OUTPUT						
175	0.78	473	0.75	452	740	1358
206	1.16	706	1.09	663	1078	1980
262	2.09	1296	1.82	1127	1295	2536
1750 RPM DRIVER-25:1 RATIO-70 RPM OUTPUT						
175	0.66	472	0.63	446	740	1380
206	0.99	706	0.92	662	1078	2143
262	1.78	1300	1.55	1129	1295	2748
1750 RPM DRIVER-30:1 RATIO-58.3 RPM OUTPUT						
175	0.55	472	0.51	441	740	1399
206	0.82	707	0.76	660	1078	2300
262	1.48	1303	1.28	1131	1295	2956
1750 RPM DRIVER-40:1 RATIO-43.7 RPM OUTPUT						
175	0.45	472	0.42	441	740	1399
206	0.66	705	0.62	657	1078	2305
262	1.19	1295	1.03	1120	1295	3096
1750 RPM DRIVER-50:1 RATIO-35 RPM OUTPUT						
175	0.36	452	0.36	452	740	1399
206	0.54	678	0.51	646	1078	2305
262	0.96	1250	0.84	1092	1295	3336
1750 RPM DRIVER-60:1 RATIO-29.1 RPM OUTPUT						
175	0.30	426	0.30	426	740	1399
206	0.45	641	0.45	641	1078	2305
262	0.79	1182	0.71	1064	1295	3410

UNIT SIZE ■	MECHANICAL		THERMAL		MAXIMUM OVERHUNG LOAD Lbs.	MAX. THRUST LOAD Lbs.
	Input HP	Output Torque	Input HP	Output Torque		
1160 RPM DRIVER-5:1 RATIO-232 RPM OUTPUT						
175	1.72	426	1.45	358	740	973
206	2.53	632	2.07	518	1078	1415
262	4.60	1160	3.59	905	1295	1776
1160 RPM DRIVER-10:1 RATIO-116 RPM OUTPUT						
175	1.01	488	0.99	477	740	1238
237	2.34	1137	1.98	960	843	1944
262	2.88	1409	2.70	1319	1295	2216
1160 RPM DRIVER-15:1 RATIO-77.3 RPM OUTPUT						
175	0.77	526	0.74	503	740	1399
206	1.13	787	1.05	731	1078	2060
262	2.11	1497	1.86	1322	1295	2536
1160 RPM DRIVER-20:1 RATIO-58 RPM OUTPUT						
175	0.60	535	0.60	535	740	1399
206	0.92	818	0.92	818	1078	2220
262	1.71	1561	1.64	1493	1295	2776
1160 RPM DRIVER-25:1 RATIO-46.4 RPM OUTPUT						
175	0.49	533	0.49	533	740	1399
206	0.76	814	0.76	814	1078	2305
262	1.42	1560	1.34	1467	1295	2978
1160 RPM DRIVER-30:1 RATIO-38.6 RPM OUTPUT						
175	0.43	528	0.43	528	740	1399
206	0.66	813	0.65	813	1078	2305
262	1.21	1554	1.12	1439	1295	3176
1160 RPM DRIVER-40:1 RATIO-29 RPM OUTPUT						
175	0.35	535	0.35	535	740	1399
206	0.53	816	0.53	816	1078	2305
262	0.99	1558	0.92	1456	1295	3176
1160 RPM DRIVER-50:1 RATIO-23.2 RPM OUTPUT						
175	0.29	508	0.29	508	740	1399
206	0.43	780	0.43	780	1078	2305
262	0.80	1485	0.73	1349	1295	3410
1160 RPM DRIVER-60:1 RATIO-19.3 RPM OUTPUT						
175	0.24	477	0.24	477	740	1399
206	0.36	734	0.36	734	1078	2305
262	0.66	1403	0.60	1284	1295	3410

■ Basic Unit Size. See Assembly Drawings, pages 110-113, to determine components needed and complete the part numbers following the directions on that page.

Above ratings are not applicable when reducer shafts are subjected to combined overhung and thrust loads.

Find ratings for input speeds not shown by straight line interpolation.

Maximum overhung loads are at center of keyseats and on one end of output shaft only. Overhung loads applied closer to the reducer housing are desirable, but overhung loads farther out on the shaft and overhung loads on both ends of output shaft should be referred to Emerson Power Transmission Technical Services.

Contact Emerson Power Transmission Technical Services at 1-800-626-2093 for the following:

1. High starting torques exceeding 300% of the reducer mechanical rating.
2. Frequent starting or repetitive shock applications.
3. Applications where high energy loads must be absorbed as when stalling.

GEARING

Corrosion Resistant Engineered Solutions

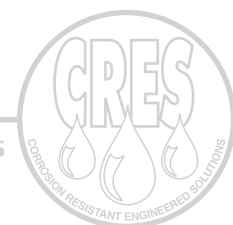

Service Factors for Enclosed Worm Gear Applications

Service factors shown apply only if electric or hydraulic motors are used. For single or multi-cylinder engines, see Table A-3 for conversion.

Table A-1

APPLICATION	Up to 3 Hrs. Day	3-10 Hrs. Day	Over 10 Hrs. Day	APPLICATION	Up to 3 Hrs. Day	3-10 Hrs. Day	Over 10 Hrs. Day
AGITATORS (Mixers)				FANS			
Pure Liquids	-	1.00	1.25	Centrifugal	-	1.00	1.25
Liquids and Solids	1.00	1.25	1.50	Cooling Towers	Refer To Tech. Service		
Liquids-Variable Density	1.00	1.25	1.50	Forced Draft	1.25	1.25	1.25
BLOWERS				Induced Draft	1.00	1.25	1.50
Centrifugal	1.00	1.25	-	Industrial & Mine	1.00	1.25	1.50
Lobe	1.00	1.25	1.50	FEEDERS			
Vane	1.00	1.25	-	Apron	-	1.25	1.50
BREWING AND DISTILLING				Belt	1.00	1.25	1.50
Bottling Machinery	-	1.00	1.25	Disc	-	1.00	1.25
Brew Kettles, Continuous Duty	-	1.00	1.25	Reciprocating	1.25	1.50	1.75
Cookers, Continuous Duty	-	1.00	1.25	Screw	1.00	1.25	1.50
Mash Tubs, Continuous Duty	-	1.00	1.25	FOOD INDUSTRY			
Scale Hopper, Frequent Starts	1.00	1.25	1.50	Cereal Cooker	-	1.00	1.25
CAN FILLING MACHINES				Dough Mixer	1.00	1.25	1.50
CAN DUMPERS	1.25	1.50	1.75	Meat Grinders	1.00	1.25	1.50
CAR PULLERS	1.00	1.25	1.50	Slicers	1.00	1.25	1.50
CLARIFIERS	1.00	1.25	-	GENERATORS AND EXCITERS	-	1.00	1.25
CLASSIFIERS	1.00	1.25	1.50	HAMMER MILLS	1.50	1.50	1.75
CLAY WORKING MACHINERY				HOISTS			
Brick Press	1.25	1.50	1.75	Heavy Duty	1.25	1.50	1.75
Briquette Machine	1.25	1.50	1.75	Medium Duty	1.00	1.25	1.50
Pug Mill	1.00	1.25	1.50	Skip Hoist	1.00	1.25	1.50
COMPACTORS	1.50	1.75	2.00	LAUNDRY TUMBLERS	1.00	1.25	1.50
COMPRESSORS				LAUNDRY WASHERS	1.25	1.25	1.50
Centrifugal	-	1.00	1.25	LUMBER INDUSTRY			
Lobe	1.00	1.25	1.50	Barkers			
Reciprocating, Multi-Cylinder	1.00	1.25	1.50	- Spindle Feed	1.25	1.25	1.25
Reciprocating, Single-Cylinder	1.25	1.50	1.75	- Main Drive	1.50	1.50	1.50
CONVEYORS - GENERAL PURPOSE				Conveyors			
Uniformly Loaded or Fed	-	1.00	1.25	- Burner	1.25	1.25	1.50
Not Uniformly Fed	1.00	1.25	1.50	- Main or Heavy Duty	1.50	1.50	1.50
Reciprocating or Shaker	1.25	1.50	1.75	- Main Log	1.50	1.50	1.50
CRANES				- Re-saw, Merry-Go-Round	1.25	1.25	1.50
Dry Dock				- Slab	1.50	1.50	1.75
Main Hoist	1.25	1.50	1.75	- Transfer	1.25	1.25	1.50
Auxiliary	1.25	1.50	1.75	Chains			
Boom Hoist	1.25	1.50	1.75	- Floor	1.50	1.50	1.50
Slewing Drive	1.25	1.50	1.75	- Green	1.50	1.50	1.50
Traction Drive	1.50	1.50	1.50	Cut-Off Saws			
Container				- Chain	1.50	1.50	1.50
Main Hoist	Refer To Tech. Service			- Drag	1.50	1.50	1.50
Boom Hoist	Refer To Tech. Service			Debarking Drums	1.50	1.50	1.75
Trolley Drive	Refer To Tech. Service			Feeds			
(Gantry Drive)				- Edger	1.25	1.25	1.50
(Traction Drive)	Refer To Tech. Service			- Gang	1.50	1.50	1.50
Mill Duty				- Trimmer	1.25	1.25	1.50
Main Hoist	Refer To Tech. Service			Log Deck	1.50	1.50	1.50
Auxiliary	Refer To Tech. Service			Log Hauls-Incline-Well Type	1.50	1.50	1.50
Bridge and				Log Turning Devices	1.50	1.50	1.50
Trolley Travel	Refer To Tech. Service			Planer Feed	1.25	1.25	1.50
Industrial Duty				Planer Tilting Hoists	1.50	1.50	1.50
Main	1.00	1.25	1.50	Rolls-Live-off Brg.-Roll Cases	1.50	1.50	1.50
Auxiliary	Refer To Tech. Service			Sorting Table	1.25	1.25	1.50
Bridge and Trolley Travel	Refer To Tech. Service			Tipple Hoist	1.25	1.25	1.50
CRUSHER				Transfers			
Stone or Ore	1.50	1.75	2.00	- Chain	1.50	1.50	1.50
DREDGES				- Causeway	1.50	1.50	1.50
Cable Reels	1.00	1.25	1.50	Tray Drives	1.25	1.25	1.50
Conveyors	1.00	1.25	1.50	Veneer Lathe Drives	Refer To Tech. Service		
Cutter Head Drives	1.25	1.50	1.75	METAL MILLS			
Pumps	1.00	1.25	1.50	Draw Bench Carriage and Main Drive	1.00	1.25	1.50
Screen Drives	1.25	1.50	1.75	Runout Table			
Stackers	1.00	1.25	1.50	Non-reversing			
Winches	1.00	1.25	1.50	Group Drives	1.00	1.25	1.50
ELEVATORS				Individual Drives	1.50	1.50	1.75
Bucket	1.00	1.25	1.50	Reversing	1.50	1.50	1.75
Centrifugal Discharge	-	1.00	1.25	Slab Pushers	1.25	1.25	1.50
Escalators	Refer To Tech. Service			Shears	1.50	1.50	1.75
Freight	Refer To Tech. Service			Wire Drawing	1.00	1.25	1.50
Gravity Discharge	-	1.00	1.25	Wire Winding Machine	1.00	1.25	1.50
EXTRUDERS				METAL STRIP PROCESSING MACHINERY			
General	1.25	1.25	1.25	Bridles	1.25	1.25	1.50
Plastics				Coilers & Uncoilers	1.00	1.00	1.25
(a) Variable Speed Drive	1.50	1.50	1.50	Edge Trimmers	1.00	1.25	1.50
(b) Fixed Speed Drive	1.75	1.75	1.75	Flatteners	1.00	1.25	1.50
Rubber				Loopers(Accumulators)	1.00	1.00	1.00
(a) Continuous Screw Operation	1.50	1.50	1.50	Pinch Rolls	1.00	1.25	1.50
(b) Intermittent Screw Operation	1.75	1.75	1.75	Scrap Choppers	1.00	1.25	1.50
				Shears	1.50	1.50	1.75
				Sitters	1.00	1.25	1.50

CRES Stainless Steel Raider Plus

Service Factors for Enclosed Worm Gear Applications

Service factors shown apply only if electric or hydraulic motors are used. For single or multi-cylinder engines, see Table A-3 for conversion.

APPLICATION	Up to 3 Hrs. Day	3-10 Hrs. Day	Over 10 Hrs. Day
MILLS, ROTARY TYPE			
Ball & Rod			
Spur Ring Gear	1.50	1.50	1.75
Helical Ring Gear	1.50	1.50	1.50
Direct Connected	1.50	1.50	1.75
Cement Kilns	1.50	1.50	1.50
Dryers & Coolers	1.50	1.50	1.50
MIXERS, CONCRETE			
PAPER MILLS			
Agitator(Mixer)	1.50	1.50	1.50
Agitator for Pure Liquids	1.25	1.25	1.25
Barking Drums	1.75	1.75	1.75
Barkers - Mechanical	1.75	1.75	1.75
Beater	1.50	1.50	1.50
Breaker Stack	1.25	1.25	1.25
Calender	1.25	1.25	1.25
Chipper	1.75	1.75	1.75
Chip Feeder	1.50	1.50	1.50
Coating Rolls	1.25	1.25	1.25
Conveyors			
Chip, Bark, Chemical	1.25	1.25	1.25
Log(Including Slab)	1.75	1.75	1.75
Couch Rolls	1.25	1.25	1.25
Cutter	1.75	1.75	1.75
Cylinder Molds	1.25	1.25	1.25
Dryers			
Paper Machine	1.25	1.25	1.25
Conveyor Type	1.25	1.25	1.25
Embosses	1.25	1.25	1.25
Extruder	1.50	1.50	1.50
Fourdrinier Rolls (Includes Lump Breaker,			
Dandy Roll, Wire Turning, and Return Rolls)	1.25	1.25	1.25
Jordan	1.25	1.25	1.25
Kiln Drive	1.50	1.50	1.50
Mt. Hope Roll	1.25	1.25	1.25
Paper Rolls	1.25	1.25	1.25
Platter	1.50	1.50	1.50
Presses- Felt & Suction	1.25	1.25	1.25
Pulper	1.50	1.50	1.75
Pumps- Vacuum	1.50	1.50	1.50
Reel (Surface Type)	1.25	1.25	1.50
Screens			
Chip	1.50	1.50	1.50
Rotary	1.50	1.50	1.50
Vibrating	1.75	1.75	1.75
Size Press	1.25	1.25	1.25
Super Calender (See Note)	1.25	1.25	1.25
Thickener			
(AC Motor)	1.50	1.50	1.50
(DC Motor)	1.25	1.25	1.25
Washer			
(AC Motor)	1.50	1.50	1.50
(DC Motor)	1.25	1.25	1.25
Wind and Unwind Stand	1.00	1.00	1.00
Winders (Surface Type)	1.25	1.25	1.25
Yankee Dryers	1.25	1.25	1.25
PLASTICS INDUSTRY - PRIMARY PROCESSING			
Intensive Internal Mixers			
(a) Batch Mixers	1.75	1.75	1.75
(b) Continuous Mixers	1.50	1.50	1.50
Batch Drop Mill - 2 Smooth Rolls	1.25	1.25	1.25
Continuous Feed, Holding & Blend Mill	1.25	1.25	1.25
Compounding Mills	1.25	1.25	1.25
Calenders	1.50	1.50	1.50
PLASTICS INDUSTRY - SECONDARY PROCESSING			
Blow Molders	1.50	1.50	1.50
Coating	1.25	1.25	1.25
Film	1.25	1.25	1.25
Pipe	1.25	1.25	1.25
Pre-Plasticizers	1.50	1.50	1.50
Rods 1.25	1.25	1.25	1.25
Sheet	1.25	1.25	1.25
Tubing	1.25	1.25	1.50
PULLERS - BARGE HAUL	1.00	1.50	1.75
PUMPS			
Centrifugal	-	1.00	1.25
Proportioning	1.00	1.25	1.50
Reciprocating			
Single Acting, 3 or More Cylinders	1.00	1.25	1.50
Double Acting, 2 or More Cylinders	1.00	1.25	1.50
Rotary			
- Gear Type	-	1.00	1.50
- Lobe	-	1.00	1.25
- Vane	-	1.00	1.25
RUBBER INDUSTRY			
Intensive Internal Mixers			
(a) Batch Mixers	1.50	1.75	1.75
(b) Continuous Mixers	1.25	1.50	1.50

APPLICATION	Up to 3 Hrs. Day	3-10 Hrs. Day	Over 10 Hrs. Day
RUBBER INDUSTRY (Continuous)			
Mixing Mill - 2 Smooth Rolls - (If corrugated			
rolls are used, then use the same service			
factors that are used for a Cracker-Warmer)	1.50	1.50	1.50
Batch Drop Mill - 2 Smooth Rolls	1.50	1.50	1.50
Cracker Warmer - 2 Roll: 1 Corrugated Roll	1.75	1.75	1.75
Cracker - 2 Corrugated Rolls	1.75	1.75	1.75
Holding, Feed & Blend Mill - 2 Rolls	1.25	1.25	1.25
Refiner - 2 Rolls	1.50	1.50	1.50
Calenders	1.50	1.50	1.50
SAND MILLER 1.00	1.25	1.50	
SEWAGE DISPOSAL EQUIPMENT			
Bar Screens	-	1.00	1.25
Chemical Feeders	-	1.00	1.25
SEWAGE DISPOSAL EQUIPMENT (Cont'd.)			
Dewatering Screens	1.00	1.25	1.50
Scum Breakers	1.00	1.25	1.50
Slow Or Rapid Mixers	1.00	1.25	1.50
Sludge Collectors	1.00	1.00	1.25
Thickener	1.00	1.25	1.50
Vacuum Filters	1.00	1.25	1.50
SCREENS			
Air Washing	-	1.00	1.25
Rotary - Stone Or Gravel	1.00	1.25	1.50
Traveling Water Intake	-	1.00	1.25
SUGAR INDUSTRY			
Beet Slicer	1.50	1.50	1.75
Cane Knives	1.50	1.50	1.50
Crushers	1.50	1.50	1.50
Mills (Low Speed End)	1.50	1.50	1.50
TEXTILE INDUSTRY			
Batches	1.00	1.25	1.50
Calenders	1.00	1.25	1.50
Cards 1.00	1.25	1.50	
Dry Cans	1.00	1.25	1.50
Dryers	1.00	1.25	1.50
Dyeing Machinery	1.00	1.25	1.50
Looms	1.00	1.25	1.50
Mangles	1.00	1.25	1.50
Nappers	1.00	1.25	1.50
Pads 1.00	1.25	1.50	
Slashers	1.00	1.25	1.50
Soapers	1.00	1.25	1.50
Spinners	1.00	1.25	1.50
Tenter Frames	1.00	1.25	1.50
Washers	1.00	1.25	1.50
Winders	1.00	1.25	1.50

* Anti-Friction Bearings Only.

NOTE: A Service Factor Of 1.0 may be applied at the base of a super calender, operating over a speed range where part of the range is constant horsepower and part of the range is constant torque, provided that the constant horsepower part is greater than 1.5 to 1. A service factor of 1.25 is applicable to super calenders operating over the entire speed range at constant torque, or where the constant horsepower speed range is less than 1.5 to 1.

Service Factors for Electric and Hydraulic Motors
(For Service Factors For Single Or Multi-Cylinder Engines, Consult Table A-3)

Duration of Service (Hours Per Day)	Uniform Load	Moderate Shock	Heavy Shock	Extreme Shock
Occasional 1/2 Hour	-	-	1.0	1.25
Less Than 3 Hours	1.0	1.0	1.25	1.50
3 - 10 Hours	1.0	1.25	1.50	1.75
Over 10 Hours	1.25	1.50	1.75	2.00

**Conversion Table for Single or Multi-Cylinder Engines to
find Equivalent Single or Multi-Cylinder Service Factors**

Hydraulic or Electric Motor	Single Cylinder Engines	Multi-Cylinder Engines
1.00	1.50	1.25
1.25	1.75	1.50
1.50	2.00	1.75
1.75	2.25	2.00
2.00	2.50	2.25

Load and operating characteristics of both the driver and driven units must be considered thoroughly when selecting EPT Speed Reducers. It is essential that all speed reducers be selected for maximum load conditions to be encountered. EPT Worm Gear Speed Reducers will safely transmit momentary starting loads as great as 300% of the mechanical input ratings.

GEARING

Corrosion Resistant Engineered Solutions



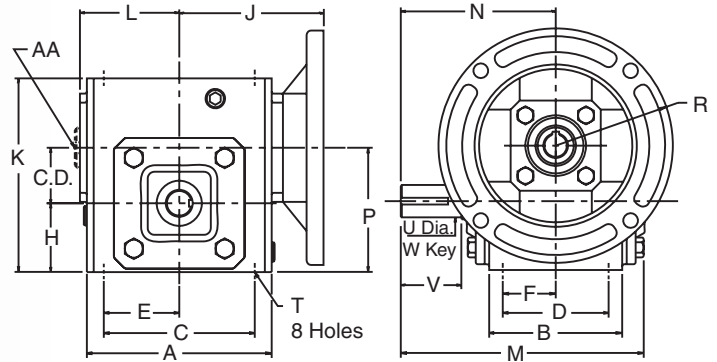

Style Q
C-Face Quilled – Basic Unit

Style Q C-Face Quilled Worm Gear Reducers

PART NUMBER ★	C.D.	NEMA FRAME	A	B	C	D	E	F	H	J	K	L	M	N	P	R
SS175Q56	1.75	56C	4.81	3.38	4.19	2.75	2.09	1.38	2.06	4.38	5.75	2.75	6.72	4.31	3.81	3.25
SS175Q140	1.75	143/145TC	4.81	3.38	4.19	2.75	2.09	1.38	2.06	4.38	5.75	2.75	6.72	4.31	3.81	3.25
SS206Q56	2.06	56C	5.50	3.75	5.00	2.88	2.50	1.44	2.28	4.75	6.38	3.00	7.29	4.69	4.34	3.25
SS206Q140	2.06	143/145TC	5.50	3.75	5.00	2.88	2.50	1.44	2.28	4.75	6.38	3.00	7.29	4.69	4.34	3.25
SS262Q56	2.62	56C	7.12	4.44	6.38	3.38	3.19	1.69	2.94	5.69	8.00	3.69	8.71	5.62	5.57	3.25
SS262Q140	2.62	143/145TC	7.12	4.44	6.38	3.38	3.19	1.69	2.94	5.69	8.00	3.69	8.71	5.62	5.57	3.25

Assembly Drawing and Sample of Components

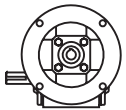

SS175Q56L10

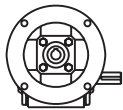

SS175Q56R10

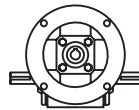

SS175Q56LR10

PART NUMBER EXPLANATION

SS 175 Q 56 L 30

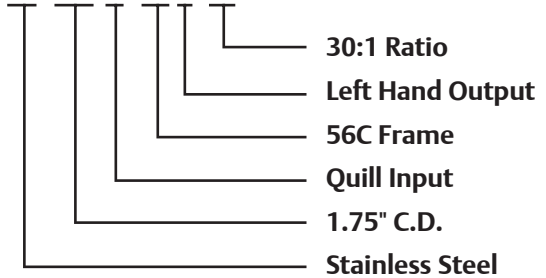

CRES Stainless Steel Raider Plus

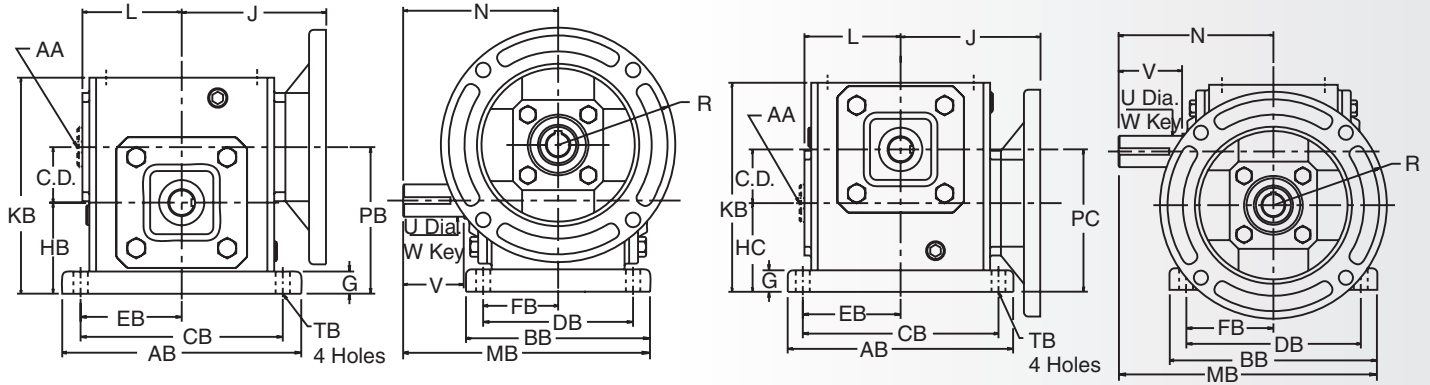

Style QT
Worm Top

Style QB
Worm Bottom

Style Q G-Face Quilled Worm Gear Reducers

N.E.M.A. FRAME	T		INPUT		OUTPUT SHAFT				STOCK RATIOS MARKED "x"								WT. LBS.	Part Number ★	
					U +.000 -.001	V	W KEY		5	10	15	20	25	30	40	50			60
	SQ.	LGTH.																	
56C	5/16-18	.61	.625	3/16 X 3/32	.875	1.88	.188	1.38	x	x	x	x	x	x	x	x	x	27.0	SS175Q56
143/145TC	5/16-18	.61	.875	3/16 X 3/32	.875	1.88	.188	1.38	x	x	x	-	-	-	-	-	-	27.0	SS175Q140
56C	3/8-16	.61	.625	3/16 X 3/32	1.000	2.00	.250	1.75	-	x	x	x	x	x	x	x	x	32.0	SS206Q56
143/145TC	3/8-16	.61	.875	3/16 X 3/32	1.000	2.00	.250	1.75	x	x	x	x	-	-	-	-	-	32.0	SS206Q140
56C	3/8-16	.58	.625	3/16 X 3/32	1.125	2.50	.250	2.00	-	x	x	x	x	x	x	x	x	50.0	SS262Q56
143/145TC	3/8-16	.58	.875	3/16 X 3/32	1.125	2.50	.250	2.00	-	x	x	x	x	x	x	x	x	50.0	SS262Q140

Style QT G-Face Quilled Worm Top, Style QB G-Face Quilled Worm Bottom

PART NUMBER	BASE KIT ♦	AB	BB	CB	DB	EB	FB	G	HB	HC	KB	MB	PB	PC	TB	WT. LBS.
SS175Q	SS175S-BK	7.00	5.56	5.75	4.50	2.88	2.25	.69	2.75	2.63	6.44	7.09	4.50	4.38	.44	28.0
SS206Q	SS206S-BK	7.69	5.76	6.38	4.69	3.19	2.34	.72	3.00	2.75	7.10	7.57	5.06	4.81	.50	33.5
SS262Q	SS262S-BK	9.25	6.50	8.00	5.25	4.00	2.63	.75	3.69	3.19	8.75	8.87	6.31	5.81	.56	52.0

★ To complete Part No. add shaft assembly (L, R, LR) and ratio symbol to size – for example SS175Q56LR10.
 ♦ Components needed to make assembled reducer must be ordered separately.

GEARING

Corrosion Resistant Engineered Solutions



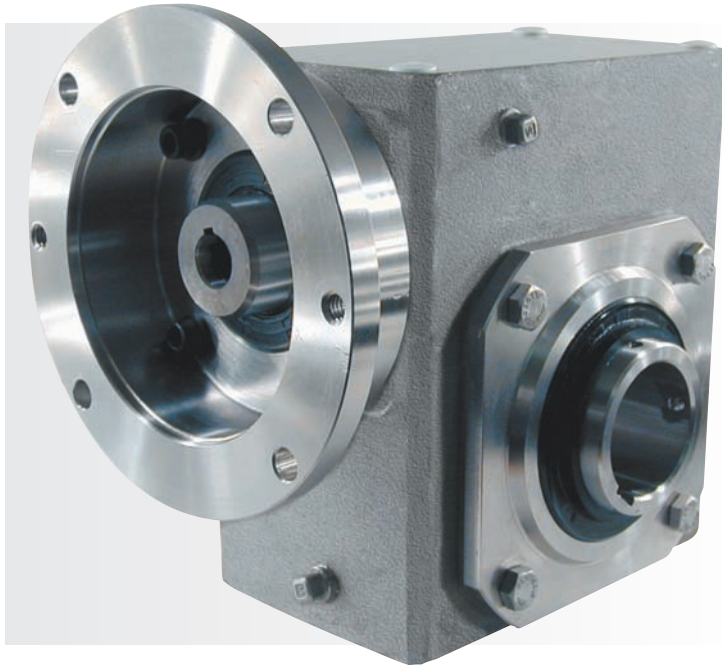

Assembly Drawing and Sample of Components

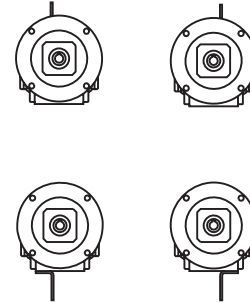

SS175Q56H10
SS175-TAK

Style QH C-Face Quilled – Hollow Style QHT Torque Arm Worm Gear Reducers

Dimensions (Inches) Style QH																
Basic Unit ★	C.D.	N.E.M.A. Frame	A	B	C	D	E	F	H	J	K	L	M	N	P	R
SS175Q56H	1.75	56C	4.81	3.38	4.19	2.75	2.09	1.38	2.06	4.38	5.75	2.75	5.70	2.85	3.81	3.25
SS175Q140H	1.75	143/145TC	4.81	3.38	4.19	2.75	2.09	1.38	2.06	4.38	5.75	2.75	5.70	2.85	3.81	3.25
SS206Q56H	2.06	56C	5.50	3.75	5.00	2.88	2.50	1.44	2.28	4.75	6.38	3.00	6.44	3.22	4.34	3.25
SS206Q140H	2.06	143/145TC	5.50	3.75	5.00	2.88	2.50	1.44	2.28	4.75	6.38	3.00	6.44	3.22	4.34	3.25
SS262Q56H	2.62	56C	7.12	4.44	6.38	3.38	3.19	1.69	2.94	5.69	8.00	3.69	6.88	3.44	5.57	3.25
SS262Q140H	2.62	143/145TC	7.12	4.44	6.38	3.38	3.19	1.69	2.94	5.69	8.00	3.69	6.88	3.44	5.57	3.25

- ★ To complete Part No. add shaft assembly (L, R, LR) and ratio symbol to size – for example SS175Q56LR10.
- ◆ Components needed to make assembled reducer must be ordered separately.
- ✚ For adapting reducers to shafts smaller than output bore, use Bushing Kits shown on page 114. Consult Emerson Power Transmission Technical Services for ratios not shown as standard.

CRES Stainless Steel Raider Plus

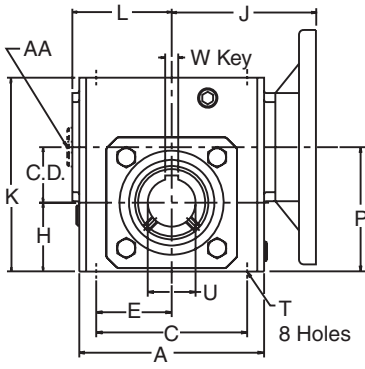

Style QH
C-Face Quilled – Hollow

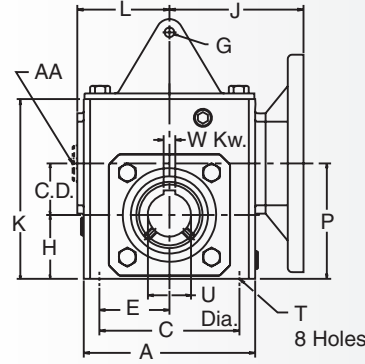
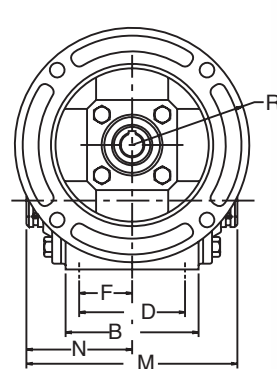

Style QHT
Torque Arm

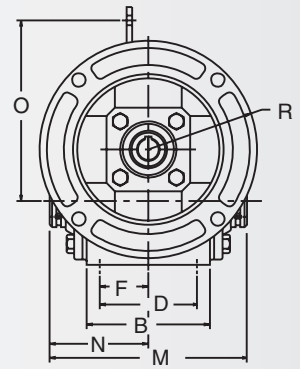

Style QH C-Face Quilled – Hollow Style QHT Torque Arm Worm Gear Reducers

Dimensions (Inches) Style QH														Dimensions (Inches) Style QHT						
T		Input		Output Bore +		Stock Ratios marked "x"								Wt. Lbs.	Components ♦		G	O	Wt. Lbs.	
				U +.0015 -.0000	W Keyway	5	10	15	20	25	30	40	50		60	Ref. No.				Torque Arm Kit
Size	Deep	Bore	Keyway																	
5/16-18	.61	.625	3/16 x 3/32	1.0000	1/4 x 1/8	x	x	x	x	x	x	x	x	x	25.0	SS175QH	SS175H-TAK	.53	5.06	25.9
5/16-18	.61	.875	3/16 x 3/32	1.0000	1/4 x 1/8	x	x	x	-	-	-	-	-	-	25.0	SS175QH	SS175H-TAK	.53	5.06	25.9
3/8-16	.61	.625	3/16 x 3/32	1.4375	3/8 x 1/8	-	x	x	x	x	x	x	x	x	33.0	SS206QH	SS206H-TAK	.53	6.07	34.0
3/8-16	.61	.875	3/16 x 3/32	1.4375	3/8 x 1/8	x	x	x	x	x	-	-	-	-	33.0	SS206QH	SS206H-TAK	.53	6.07	34.0
3/8-16	.58	.625	3/16 x 3/32	1.9375	1/2 x 1/8	-	x	x	x	x	x	x	x	x	57.0	SS262QH	SS262H-TAK	.53	77.44	58.4
3/8-16	.58	.875	3/16 x 3/32	1.9375	1/2 x 1/8	-	x	x	x	x	x	x	x	x	57.0	SS262QH	SS262H-TAK	.53	77.44	58.4

GEARING

Corrosion Resistant Engineered Solutions



SS Raider Plus Stainless Accessories

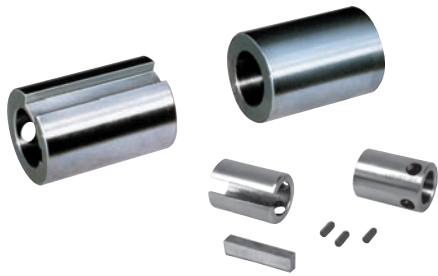

Table 1 Bushings for SS Raider Plus Hollow Shaft Reducers

Reducer C.D.	Shaft Dia.	Shaft Keyseat	Bushing Kit No.	Wt. Lbs.
1.75	3/4	3/16 x 3/32 x 1 1/8	SS100BU012	.3
	7/8	3/16 x 3/32 x 1 1/8	SS100BU014	.1
	15/16	1/4 x 1/8 x 1 1/8	SS100BU015	.1
2.06	3/4	3/16 x 3/32 x 2	SS107BU012	1.4
	7/8	3/16 x 3/32 x 2	SS107BU014	1.2
	15/16	1/4 x 1/8 x 2	SS107BU015	1.1
	1	1/4 x 1/8 x 2	SS107BU100	1.0
	1 1/16	1/4 x 1/8 x 2	SS107BU101	.9
	1 1/8	1/4 x 1/8 x 2	SS107BU102	.8
	1 3/16	1/4 x 1/8 x 2	SS107BU103	.6
	1 1/4	1/4 x 1/8 x 2	SS107BU104	.5
2.62	1 5/16	5/16 x 5/32 x 2	SS107BU105	.4
	15/16	1/4 x 1/8 x 2 1/2	SS115BU015	3.2
	1	1/4 x 1/8 x 2 1/2	SS115BU100	3.1
	1 1/6	1/4 x 1/8 x 2 1/2	SS115BU101	3.0
	1 1/8	1/4 x 1/8 x 2 1/2	SS115BU102	2.8
	1 3/16	1/4 x 1/8 x 2 1/2	SS115BU103	2.7
	1 1/4	1/4 x 1/8 x 2 1/2	SS115BU104	2.5
	1 5/16	5/16 x 5/32 x 2 1/2	SS115BU105	2.3
	1 3/8	5/16 x 5/32 x 2 1/2	SS115BU106	2.1
	1 7/16	3/8 x 3/16 x 2 1/2	SS115BU107	1.9
	1 1/2	3/8 x 3/16 x 2 1/2	SS115BU108	1.7
	1 5/8	3/8 x 3/16 x 2 1/2	SS115BU110	1.3
	1 11/16	3/8 x 3/16 x 2 1/2	SS115BU111	1.1
1 3/4	3/8 x 3/16 x 2 1/2	SS115BU112	.8	

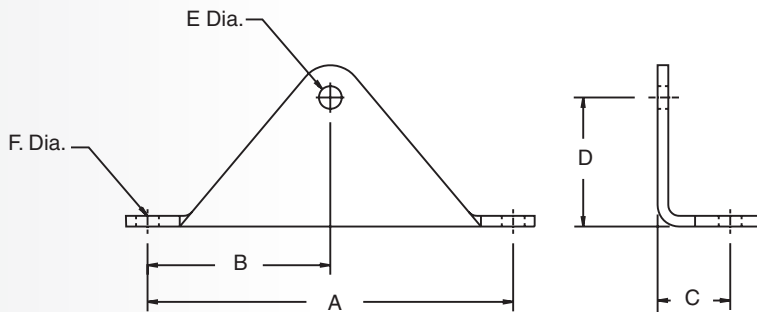

Table 2 Dimensions for Torque Arm Kit

Part No.	A	B	C	D	E	F	Wt./Lbs.
SS175-TAK	4.19	2.09	.95	1.38	.53	.344	.9
SS206-TAK	5.00	2.50	1.28	1.97	.53	.406	1.0
SS262-TAK	6.38	3.19	1.31	2.38	.53	.406	1.4

CRES Stainless Steel Raider Plus

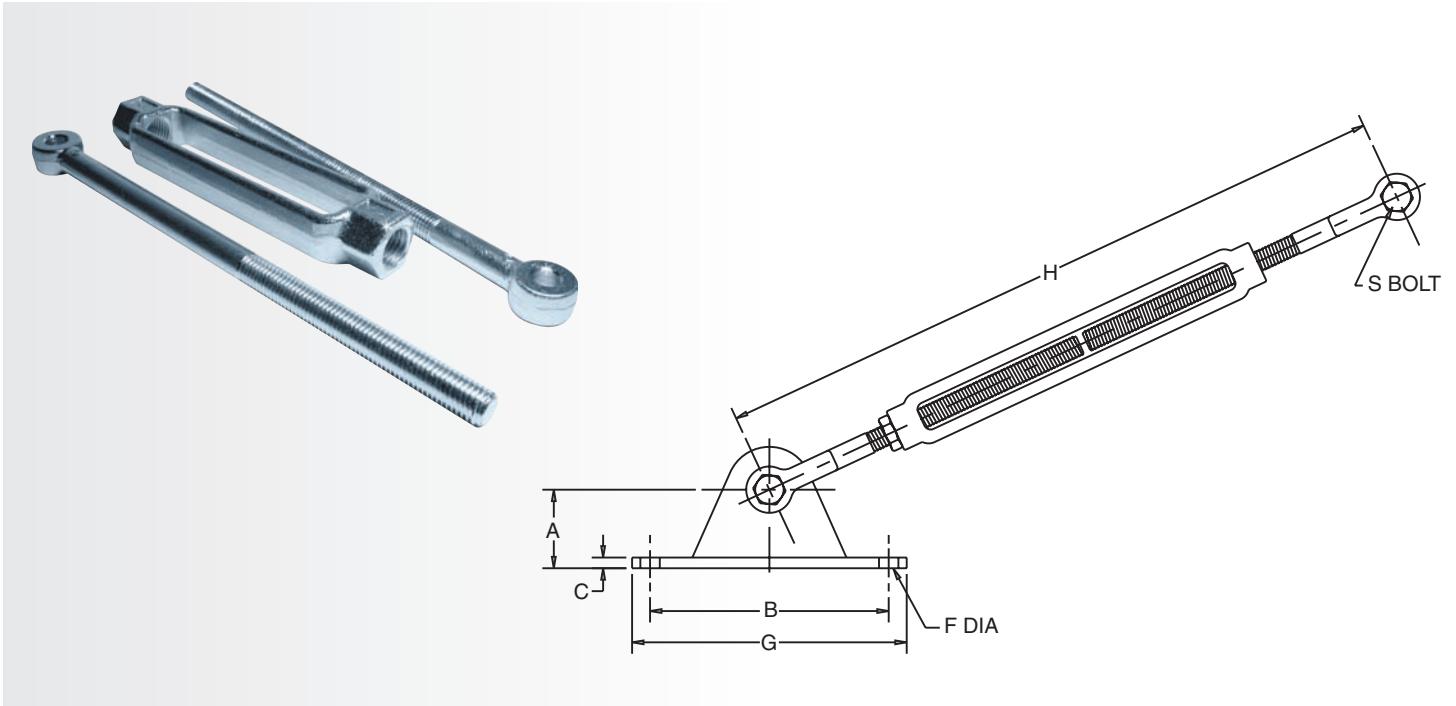

Table 3 Dimensions for Adjustable Torque Arm Kit

Part No.	A	B	C	F	G	H	S	Wt./Lbs.
SS175-262ATAK	1.38	4.187	.187	.34	4.81	12.00-17.50	5/16	2.0

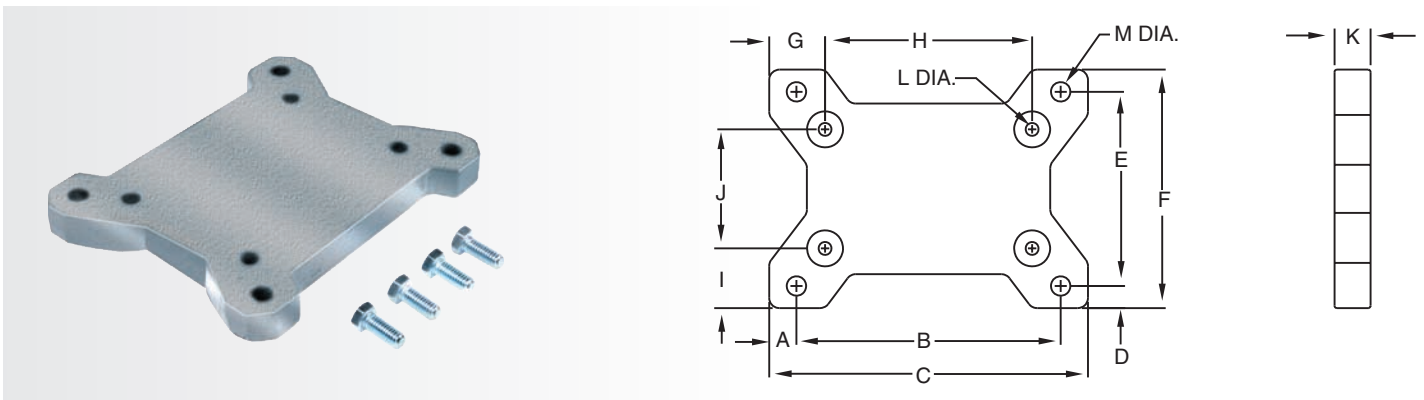

Table 4 Dimensions for Solid Horizontal One Piece Base

Part No.	A	B	C	D	E	F	G	H	I	J	K	L Dia.	M Dia.
SS175-BK	.62	5.75	7.00	.53	4.50	5.56	1.41	4.19	1.40	2.75	.69	.38	.44
SS206-BK	.66	6.38	7.69	.53	4.69	5.76	1.35	5.00	1.44	2.88	.72	.44	.50
SS262-BK	.63	8.00	9.25	.62	5.25	6.50	1.44	6.38	1.56	3.38	.75	.44	.56

GEARING

Corrosion Resistant Engineered Solutions



State-of-the-Art Features Built into Every Paint Free Washdown Motor

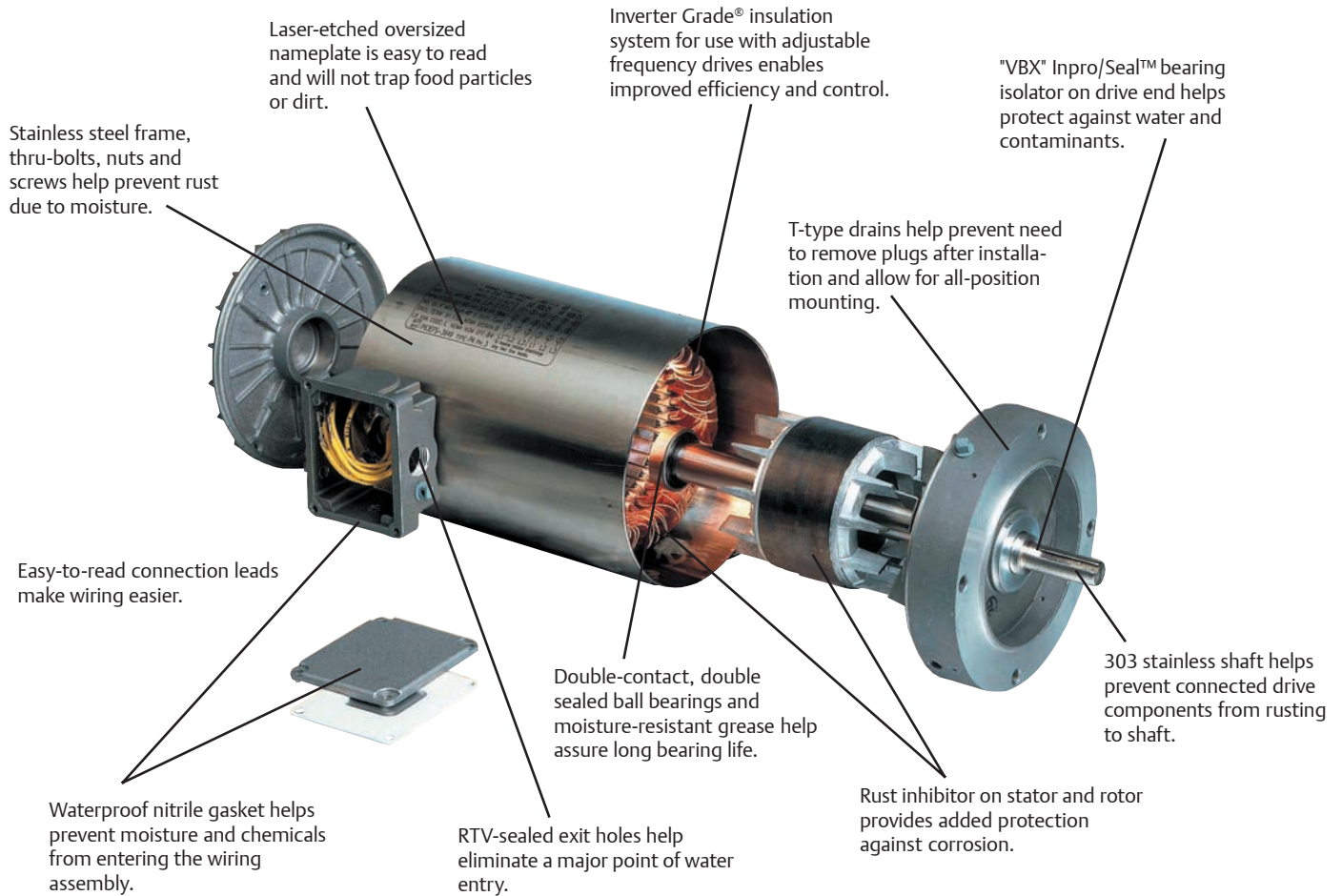

Inverter Grade is a registered trademark of Emerson Electric Co.

C-Face without Base – 1725 RPM

CATALOG NUMBER	HP	VOLTS	NEMA FRAME	SF	AMPS	OVERALL LENGTH INCLUDING SHAFT	SHAFT DIA.	SHAFT LENGTH	SHIP WGT.
WDP12S2ACR	1/2	208-230/460	56C	1.15	2.0-1.9/0.9	12.38	.625	2.06	36
WDP34S2ACR	3/4	208-230/460	56C	1.15	2.8-2.7/1.3	12.38	.625	2.06	38
WDP1S2AFCR	1	208-230/460	56C	1.15	3.5-3.4/1.7	12.75	.625	2.06	37
WDP1S2ACR	1	208-230/460	145TC	1.15	3.5-3.4/1.7	14.06	.875	2.13	37
WDP32S2AFCR	1 1/2	208-230/460	56C	1.00	4.9-4.8/2.4	13.75	.625	2.06	39
WDP32S2ACR	1 1/2	208-230/460	145TC	1.00	4.9-4.8/2.4	13.81	.875	2.13	39
WDP2S2AFCR	2	208-230/460	56C	1.00	6.5-6.3/3.3	14.00	.625	1.90	44
WDP2S2ACR	2	208-230/460	145TC	1.00	6.5-6.3/3.3	14.00	.875	1.90	44

CRES Stainless Steel Raider Plus

Input Horsepower, Output Torque, Overhung Loads and Thrust Loads for C-Flange Single Reduction Worm Gear Reducers and A.C. Motors

1.00 SF

Reducer Part No.	Motor HP	Motor Part No.	Output Torque In.-Lbs.	Output Shaft	
				Max. Overhung Load - Lbs.	Max. Thrust Load - Lbs.
1750 R.P.M. Driver - 5:1 Ratio - 350 R.P.M. Output					
SS175Q56	1/2	WDP12S2ACR	83	663	868
SS175Q56	3/4	WDP34S2ACR	124	663	868
SS175Q56	1	WDP1S2AFCR	165	663	868
SS175Q140	1	WDP1S2ACR	165	663	868
SS175Q56	1 1/2	WDP32S2AFCR	248	663	868
SS175Q140	1 1/2	WDP32S2ACR	248	663	868
SS206Q56	2	WDP2S2AFCR	335	913	1265
SS206Q140	2	WDP2S2ACR	335	913	1265
1750 R.P.M. Driver - 10:1 Ratio - 175 R.P.M. Output					
SS175Q56	1/2	WDP12S2ACR	162	740	1098
SS206Q56	1/2	WDP12S2ACR	162	1078	1580
SS175Q56	3/4	WDP34S2ACR	244	740	1098
SS206Q56	3/4	WDP34S2ACR	244	1078	1580
SS175Q56	1	WDP1S2AFCR	325	740	1098
SS175Q140	1	WDP1S2ACR	325	740	1098
SS206Q56	1 1/2	WDP32S2AFCR	489	1078	1580
SS206Q140	1 1/2	WDP32S2ACR	489	1078	1580
SS262Q56	2	WDP2S2AFCR	657	1295	1976
SS262Q140	2	WDP2S2ACR	657	1295	1976
1750 R.P.M. Driver - 15:1 Ratio - 116.6 R.P.M. Output					
SS175Q56	1/2	WDP12S2ACR	233	740	1253
SS206Q56	1/2	WDP12S2ACR	238	1078	1820
SS175Q56	3/4	WDP34S2ACR	350	740	1253
SS206Q56	3/4	WDP34S2ACR	357	1078	1820
SS206Q56	1	WDP1S2AFCR	475	1078	1820
SS206Q140	1	WDP1S2ACR	475	1078	1820
SS262Q56	1 1/2	WDP32S2AFCR	719	1295	2296
SS262Q140	1 1/2	WDP32S2ACR	719	1295	2296
SS262Q56	2	WDP2S2AFCR	959	1295	2296
SS262Q140	2	WDP2S2ACR	959	1295	2296
1750 R.P.M. Driver - 20:1 Ratio 87.5 R.P.M. Output					
SS175Q56	1/2	WDP12S2ACR	303	740	1358
SS206Q56	1/2	WDP12S2ACR	303	1078	1980
SS175Q56	3/4	WDP34S2ACR	455	740	1358
SS206Q56	3/4	WDP34S2ACR	455	1078	1980
SS206Q56	1	WDP1S2AFCR	609	1078	1980
SS206Q140	1	WDP1S2ACR	609	1078	1980
SS262Q56	1 1/2	WDP32S2AFCR	930	1295	2536
SS262Q140	1 1/2	WDP32S2ACR	930	1295	2536
1750 R.P.M. Driver - 25:1 Ratio 70 R.P.M. Output					
SS175Q56	1/2	WDP12S2ACR	357	740	1380
SS206Q56	1/2	WDP12S2ACR	357	1078	2143
SS206Q56	3/4	WDP34S2ACR	535	1078	2143
SS262Q56	3/4	WDP34S2ACR	548	1295	2748
SS262Q56	1	WDP1S2AFCR	730	1295	2748
SS262Q140	1	WDP1S2ACR	730	1295	2748
SS262Q56	1 1/2	WDP32S2AFCR	1095	1295	2748
SS262Q140	1 1/2	WDP32S2ACR	1095	1295	2748
1750 R.P.M. Driver - 30:1 Ratio 58.3 R.P.M. Output					
SS175Q56	1/2	WDP12S2ACR	429	740	1399
SS206Q56	1/2	WDP12S2ACR	429	1078	2300
SS206Q56	3/4	WDP34S2ACR	647	1078	2300
SS262Q56	3/4	WDP34S2ACR	660	1295	2956
SS262Q56	1	WDP1S2AFCR	880	1295	2956
SS262Q140	1	WDP1S2ACR	880	1295	2956
1750 R.P.M. Driver - 40:1 Ratio 43.7 R.P.M. Output					
SS206Q56	1/2	WDP12S2ACR	534	1078	2305
SS262Q56	1/2	WDP12S2ACR	544	1295	3096
SS262Q56	3/4	WDP34S2ACR	816	1295	3096
SS262Q56	1	WDP1S2AFCR	1088	1295	3096
SS262Q140	1	WDP1S2ACR	1088	1295	3096
1750 R.P.M. Driver - 50:1 Ratio 35 R.P.M. Output					
SS206Q56	1/2	WDP12S2ACR	628	1078	2305
SS262Q56	1/2	WDP12S2ACR	651	1295	3336
SS262Q56	3/4	WDP34S2ACR	976	1295	3336
1750 R.P.M. Driver - 60:1 Ratio 29.1 R.P.M. Output					
SS262Q56	1/2	WDP12S2ACR	748	1295	3410

GEARING

Corrosion Resistant Engineered Solutions





Input Horsepower, Output Torque, Overhung Loads and Thrust Loads for C-Flange Single Reduction Worm Gear Reducers and A.C. Motors

1.50 SF

Reducer Part No.	Motor HP	Motor Part No.	Output Torque In.-Lbs.	Output Shaft	
				Max. Overhung Load - Lbs.	Max. Thrust Load - Lbs.
1750 R.P.M. Driver - 5:1 Ratio - 350 R.P.M. Output					
SS175Q56	1/2	WDP12S2ACR	83	663	868
SS175Q56	3/4	WDP34S2ACR	124	663	868
SS175Q56	1	WDP1S2AFCR	165	663	868
SS175Q140	1	WDP1S2ACR	165	663	868
SS206Q140	1 1/2	WDP32S2ACR	251	913	1265
SS206Q140	2	WDP2S2ACR	335	913	1265
1750 R.P.M. Driver -10:1 Ratio - 175 R.P.M. Output					
SS175Q56	1/2	WDP12S2ACR	162	740	1098
SS206Q56	1/2	WDP12S2ACR	162	1078	1580
SS175Q56	3/4	WDP34S2ACR	244	740	1098
SS206Q56	3/4	WDP34S2ACR	244	1078	1580
SS206Q56	1	WDP1S2AFCR	326	1078	1580
SS206Q140	1	WDP1S2ACR	326	1295	1976
SS262Q56	1 1/2	WDP32S2AFCR	493	1295	1976
SS262Q140	1 1/2	WDP32S2ACR	493	1295	1976
SS262Q56	2	WDP2S2AFCR	657	1295	1976
SS262Q140	2	WDP2S2ACR	657	1295	1976
1750 R.P.M. Driver -15:1 Ratio -116.6 R.P.M. Output					
SS175Q56	1/2	WDP12S2ACR	233	740	1253
SS206Q56	1/2	WDP12S2ACR	237	1078	1820
SS206Q56	3/4	WDP34S2ACR	357	1078	1820
SS262Q56	3/4	WDP34S2ACR	360	1295	2296
SS262Q56	1	WDP1S2AFCR	480	1295	2296
SS262Q140	1	WDP1S2ACR	480	1295	2296
SS262Q56	1 1/2	WDP32S2AFCR	719	1295	2296
SS262Q140	1 1/2	WDP32S2ACR	719	1295	2296
1750 R.P.M. Driver -20:1 Ratio 87.5 R.P.M. Output					
SS175Q56	1/2	WDP12S2ACR	303	740	1358
SS206Q56	1/2	WDP12S2ACR	304	1078	1980
SS206Q56	3/4	WDP34S2ACR	456	1078	1980
SS262Q56	3/4	WDP34S2ACR	465	1295	2536
SS262Q56	1	WDP1S2AFCR	620	1295	2536
SS262Q140	1	WDP1S2ACR	620	1295	2536
1750 R.P.M. Driver -25:1 Ratio 70 R.P.M. Output					
SS206Q56	1/2	WDP12S2ACR	356	1078	2143
SS262Q56	1/2	WDP12S2ACR	365	1295	2748
SS262Q56	3/4	WDP34S2ACR	548	1295	2748
SS262Q56	1	WDP1S2AFCR	730	1295	2748
SS262Q140	1	WDP1S2ACR	730	1295	2748
1750 R.P.M. Driver -30:1 Ratio 58.3 R.P.M. Output					
SS206Q56	1/2	WDP12S2ACR	431	1078	2300
SS262Q56	1/2	WDP12S2ACR	440	1295	2956
SS262Q56	3/4	WDP34S2ACR	660	1295	2956
1750 R.P.M. Driver -40:1 Ratio 43.7 R.P.M. Output					
SS262Q56	1/2	WDP12S2ACR	544	1295	3096
SS262Q56	3/4	WDP34S2ACR	816	1295	3096
1750 R.P.M. Driver -50:1 Ratio 35 R.P.M. Output					
SS262Q56	1/2	WDP12S2ACR	651	1295	3336
1750 R.P.M. Driver -60:1 Ratio 29.1 R.P.M. Output					
SS262Q56	1/2	WDP12S2ACR	748	1295	3410

CRES Stainless Steel Raider Plus

Input Horsepower, Output Torque, Overhung Loads and Thrust Loads for C-Flange Single Reduction Worm Gear Reducers and A.C. Motors

2.0 SF

Reducer Part No.	Motor HP	Motor Part No.	Output Torque In.-Lbs.	Output Shaft	
				Max. Overhung Load - Lbs.	Max. Thrust Load - Lbs.
1750 R.P.M. Driver - 5:1 Ratio - 350 R.P.M. Output					
SS175Q56	1/2	WDP12S2ACR	83	663	868
SS175Q56	3/4	WDP34S2ACR	124	663	868
SS175Q56	1	WDP1S2AFCR	165	663	868
SS175Q140	1	WDP1S2ACR	165	663	868
SS206Q140	1 1/2	WDP32S2ACR	252	913	1265
SS262Q56	2	WDP2S2AFCR	338	1295	1596
1750 R.P.M. Driver -10:1 Ratio - 175 R.P.M. Output					
SS175Q56	1/2	WDP12S2ACR	162	740	1098
SS206Q56	1/2	WDP12S2ACR	162	1078	1580
SS206Q56	3/4	WDP34S2ACR	244	1078	1580
SS262Q56	1	WDP1S2AFCR	328	1295	1976
SS262Q140	1	WDP1S2ACR	328	1295	1976
SS262Q56	1 1/2	WDP32S2AFCR	493	1295	1976
SS262Q140	1 1/2	WDP32S2ACR	493	1295	1976
1750 R.P.M. Driver -15:1 Ratio -116.6 R.P.M. Output					
SS206Q56	1/2	WDP12S2ACR	238	1078	1820
SS262Q56	1/2	WDP12S2ACR	238	1295	2296
SS262Q56	3/4	WDP34S2ACR	360	1295	2296
SS262Q56	1	WDP1S2AFCR	480	1295	2296
SS262Q140	1	WDP1S2ACR	480	1295	2296
1750 R.P.M. Driver -20:1 Ratio 87.5 R.P.M. Output					
SS206Q56	1/2	WDP12S2ACR	304	1078	1980
SS262Q56	1/2	WDP12S2ACR	304	1295	2536
SS262Q56	3/4	WDP34S2ACR	465	1295	2536
SS262Q56	1	WDP1S2AFCR	620	1295	2536
SS262Q140	1	WDP1S2ACR	620	1295	2536
1750 R.P.M. Driver -25:1 Ratio 58.3 R.P.M. Output					
SS262Q56	1/2	WDP12S2ACR	365	1295	2748
SS262Q56	3/4	WDP34S2ACR	548	1295	2748
1750 R.P.M. Driver -30:1 Ratio 70 R.P.M. Output					
SS262Q56	1/2	WDP12S2ACR	440	1295	2956
1750 R.P.M. Driver -40:1 Ratio 43.7 R.P.M. Output					
SS262Q56	1/2	WDP12S2ACR	544	1295	3096

For 1.25 and 1.75 SF contact Emerson Power Transmission Services at 1-800-626-2093.

GEARING

Corrosion Resistant Engineered Solutions



CRES Coatings *USDA and FDA Accepted*

These corrosion-resistant coating options are available today in all sizes for the complete line of Browning and Morse speed reducers and gearmotors. They complement our premium corrosion-resistant engineered solutions, including all the stainless steel Morse Raider Plus offerings for the ultimate in corrosion resistance.



White Epoxy Coating – Corro-Duty White

316 Stainless Steel Coating – Corro-Duty Gray

Corrosion – Resistant Coatings

316 Stainless Steel Coating – Corro-Duty Gray

A rugged, three -step process produces a superb corrosion duty coating that works well in wet, corrosion environments. The metallic gray coating is USDA and FDA accepted with a 316 stainless steel pigment.

White Epoxy Coating – Corro-Duty White

This two-step coatings is the traditional food-grade white epoxy often used in demanding, corrosive food and beverage applications and is also USDA and FDA accepted.

Expanded, Corrosion-Resistant Coatings

- Do your applications include food, chemical, or poultry processing?
- Is your equipment outdoors and exposed to the elements?
- Are your gearing products subjected to extreme humidity, washdown, steam, caustic detergents or mild acids?

Call Emerson Power Transmission
for your Corrosion-Resistant Gearing Solutions.
1-800-626-2120

Please specify **Corro-Duty Gray** or **Corro-Duty White** when ordering.

Available on:

- Worm Gear Reducers and Gearmotors
- Helical In-Line and Right Angle Speed Reducers and Gearmotors

GEARING

Corrosion Resistant Engineered Solutions



CRES Components

Emerson Power Transmission's CRES line of components design their products with the rigors of the food and industries in mind. Emerson Power Transmission has products designed to inhibit bacterial growth and operate in harsh cleaning environments. This includes corrosion resistant roller chain and stainless steel sprockets, Ultop®, Matveyor® and Topveyor® conveying chains, stainless steel clutches and torque overload devices.

Emerson Power Transmission's application focused engineering results in a wide array of power transmission products that work together to meet the unique needs of food and beverage processing. In this way, Emerson Power Transmission acts as a single-source-supplier so manufacturers can seamlessly integrate equipment, while reducing the number of people needed to provide solutions and keep lines running.

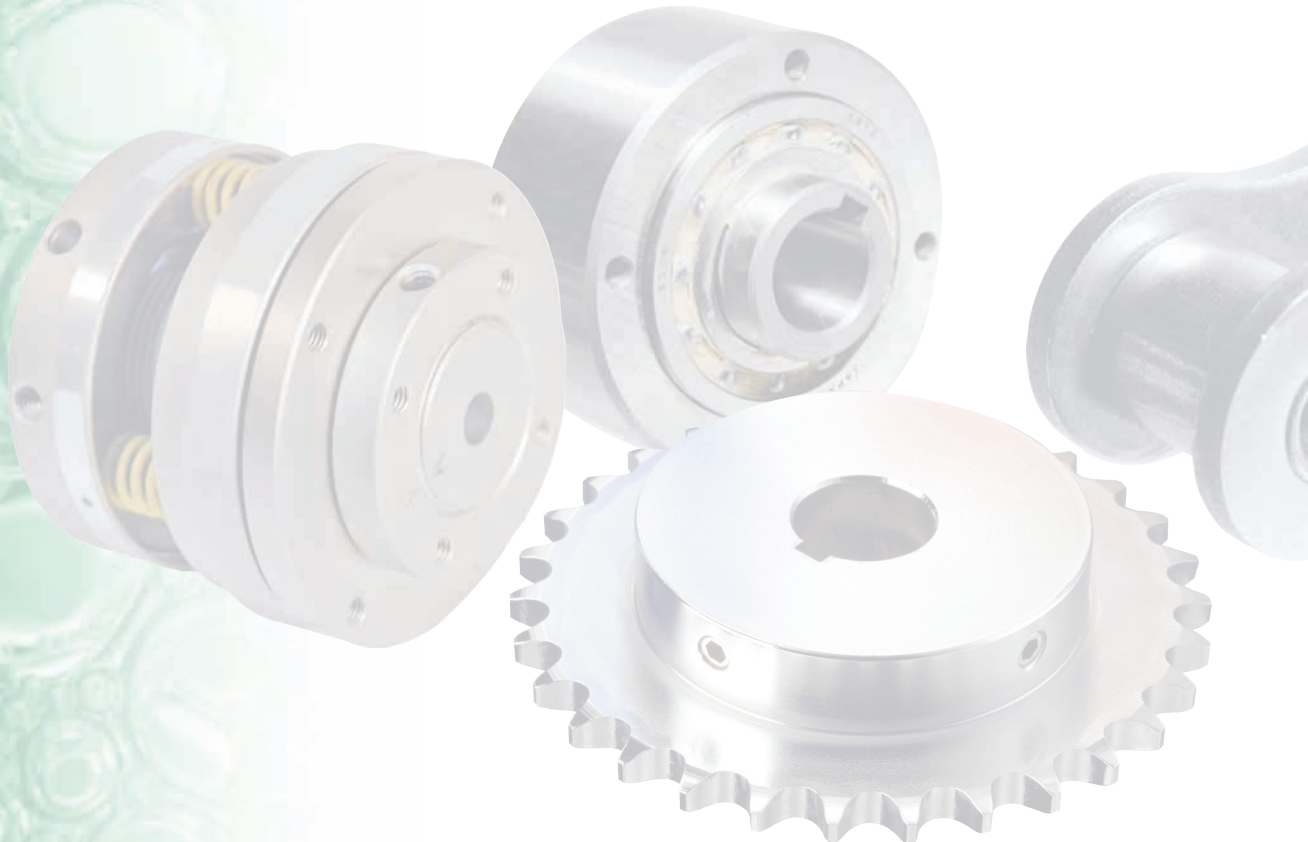

CRES Components

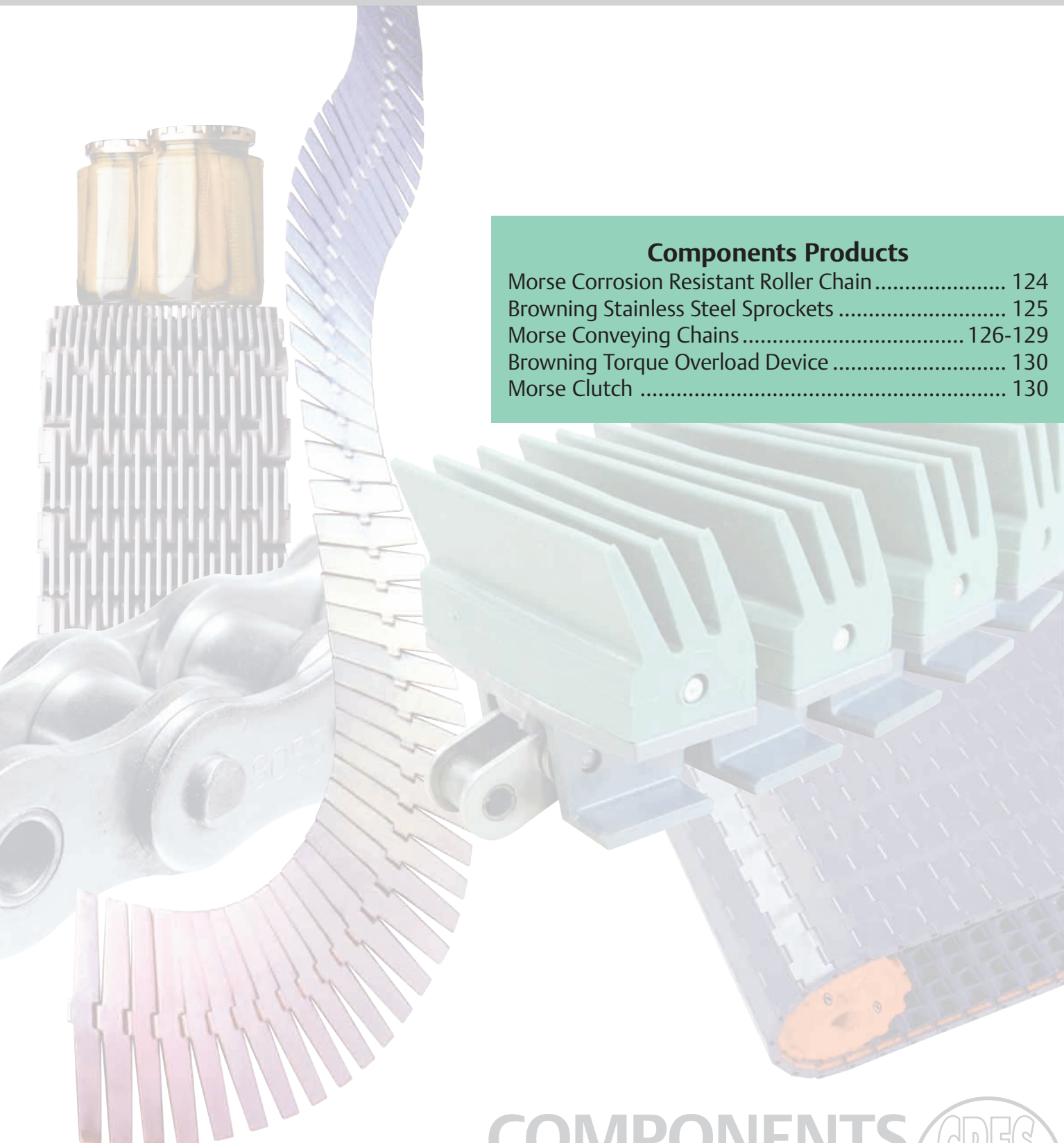

Components Products

Morse Corrosion Resistant Roller Chain	124
Browning Stainless Steel Sprockets	125
Morse Conveying Chains	126-129
Browning Torque Overload Device	130
Morse Clutch	130

COMPONENTS

Corrosion Resistant Engineered Solutions



CRES MORSE *Roller Chain*

Morse provides a wide range of high quality roller chain solutions to meet application needs for many different industries. With 100 years of experience in manufacturing domestic chain products that meet or exceed industry standard; Morse delivers exceptional customer value.

Morse offers several corrosion resistant roller chain solutions to help customers with challenging applications in harsh environments.



Chain Types

Morse provides corrosion resistant materials for most chain styles.

Moisture Guard® Chain

- Corrosion protection with high strength and wear resistance
- Plated before assembly for through corrosion protection
- Custom Moisture Guard chain available for design according to your application needs for materials, platings, coatings and lubricants
- Stocked in 35 through 80 pitch in 10 ft. packages or cut-to-length

How to Order:

Simply add an MG after the pitch size. For example, order 60MG R for 60 pitch riveted Moisture Guard Chain.

Nickel Plated Roller Chain

- High quality nickel plating applied to chain parts prior to assembly
- Outstanding appearance and corrosion resistance
- Many sizes available from stock, with or without attachments – other sizes and special attachments available upon request

Stainless Steel Roller Chain

- 300 Series stainless steel for the most corrosive environments
- Stocked in 25 through 120, including popular attachments – other sizes and special attachments also available

Corrosion Resistant Attachment Chain

- Available in standard carbon steel, nickel plated, Moisture Guard, stainless steel and custom designs on a made-to-order basis

Stainless Steel Sprockets

- Provides a complete, corrosion resistant chain drive with stainless steel sprockets
- Available in 35 through 80 pitch in A-plate and B-plate styles
- Popular sizes stocked
- Custom sprockets also available to meet the most challenging applications

For customer service, contact the Specialty Chain Center at 1-888-378-7223

For customized chain solutions, contact Application Engineering at 1-800-626-2093 or by email at tech-service@emerson-ept.com to solve your chain corrosion problems

ASTMB-117 • 500 Hour Salt Spray Test



Competitor "Water Proof" Chain



Morse Moisture Guard® Chain

COMPONENTS

Corrosion Resistant Engineered Solutions



CRES MORSE *Conveying Chains*

Morse offers three lines of fully-integrated conveying chains. These high quality, high performance systems handle a multiplicity of tough container handling tasks and offers optimum versatility, variety and value.

1. Utop Family of Conveyor Chain
2. Matveyor Modular Plastic Chain
3. Topveyor Conveying Chain



Utop Chain



Matveyor Chain



Topveyor Chain

CRES Conveying Chains

Utop Chain

The ultimate in container handling! Built for speed and smooth performance. To Address today's *Hot Issues* in beverage plants.

- Increased speed of production lines
- Improved product stability, even with light weight products
- Dry running, eliminate soap lubricants
- Reduced downtime and maintenance
- Active Transfer Modules for smooth, continuous product transfer at 90 degree corners

Matveyor Chain

Brickable width plastic belting with performance materials to match challenging conveying applications.

- **Series 1010** Light duty 1" pitch products ideally suited to a wide variety of general package and container handling applications
- **Series 3000** Heavy duty 2" pitch belts applicable for larger warmers, coolers, mass accumulation, and general conveying
- **Series 5000** Modularity in a turn-style belt ideal for many food production and processing applications

Topveyor Chain

The TOP choice for problem-solving. Tops in interchangeability and specialty chain choices.

- Carbon and stainless steel chains
- Advanced thermoplastic materials
- Straight running, side flexing and multi-flex
- Split and solid sprockets

COMPONENTS

Corrosion Resistant Engineered Solutions



CRES MORSE *Gripper Chain*

For your bottle handling applications consider Morse gripper chain. Flexible, rubber grippers maintain their original shape and elasticity and are specifically designed to exert the appropriate amount of force onto containers. The proprietary flight material also decreases forces on chain flights, reducing chain pull and dramatically increasing base chain life. Additionally, stainless steel pins hold grippers to flights, and keep them from coming off during machine jams.

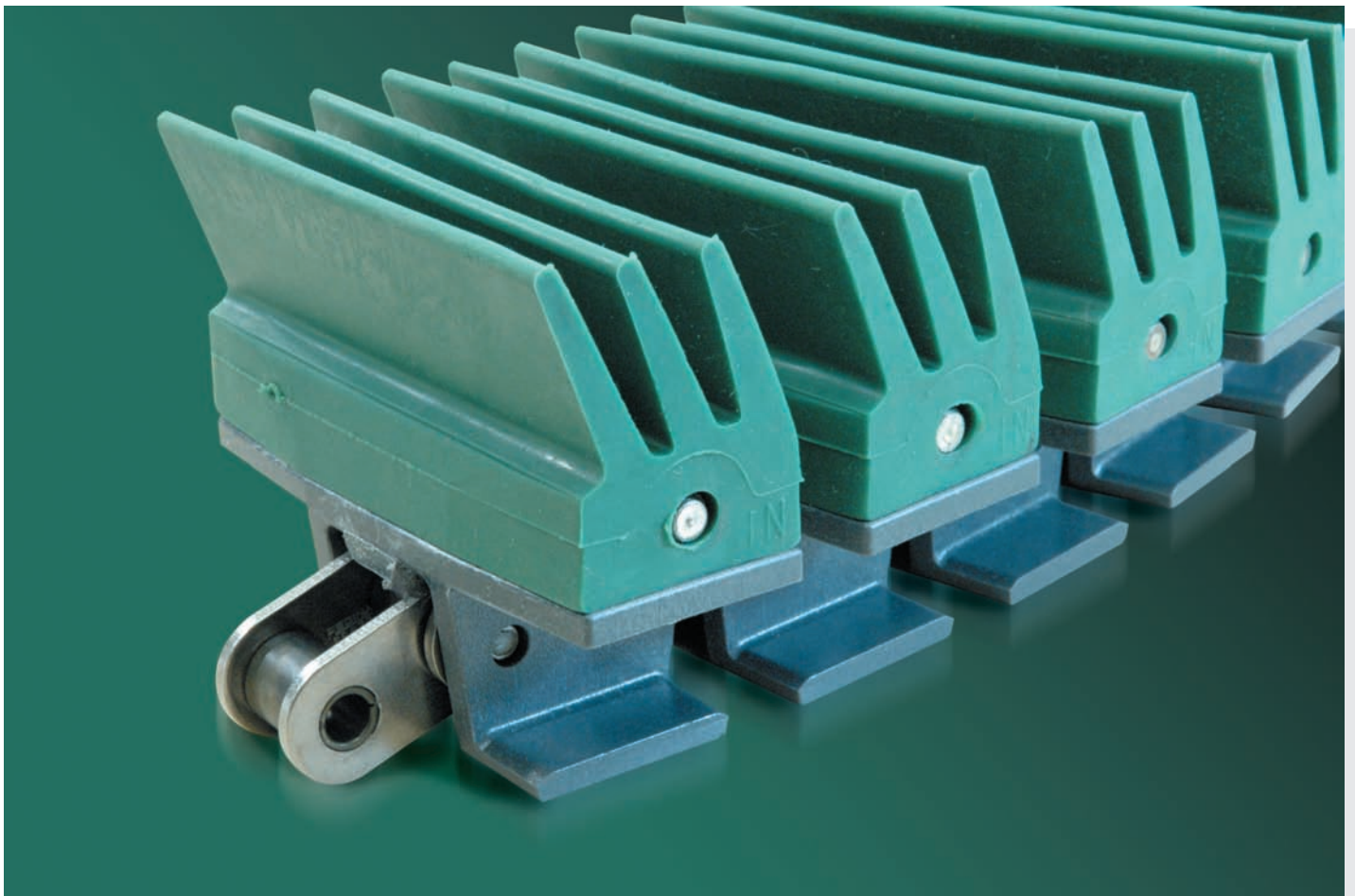

Thermoplastic, Rubber Chain

- Flexible, thermoplastic, rubber retains memory so grippers return to their original shape and consistency
- Grippers available with shorter fingers that exert a higher force on conveyed products — particularly suitable for heavier containers and packaged products
- Fingers flex without increasing force on the product and the conveyor — making it suitable for conveying glass containers
- Some models offers a flat, more continuous contact surface between the rubber and the conveyed product

Base Roller Chain

- 3/4" pitch
- Carbon steel for mechanical strength and resistance to elongation
- Stainless steel for mechanical strength and corrosion resistance

Benefit Summary

- Gripper chain exerts the right amount of force so container deformation is not an issue
- Pliable rubber grippers retain shape and consistency
- Grippers securely fastened to flight by a stainless steel pin that helps eliminate pop-offs and provides smooth, rapid movement
- Fingers cover a larger area of containers — providing better handling abilities
- Stainless and carbon steel base chain options for mechanical strength and corrosion resistance
- DK flights provide excellent wear resistance, help reduce elongation of stainless steel base chain and result in less dusting

Browning®

Solutions for Harsh Environments

Torq/Pro® X Torque Overload Device

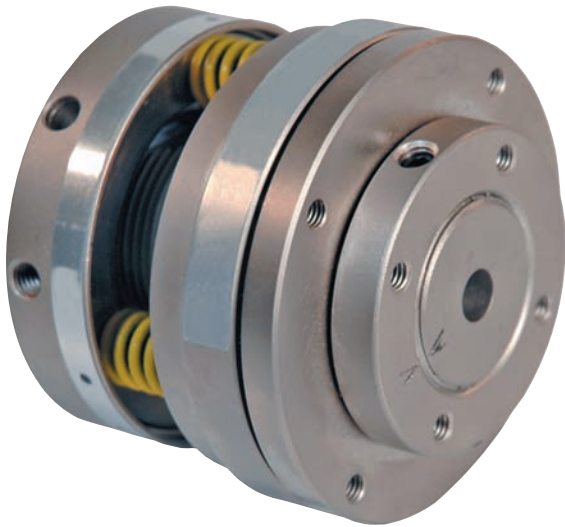

Features

- Patent pending, innovative ball and wedge mechanism, helps prevent backlash
- Ball and pocket are uniquely designed to fit together in only one position
- Adjust trip torque by simply turning the adjustment nut
- Torque setting can be easily verified by checking the torque scale and indicator

Bore range 0.28" - 2.75"

Output range 1.25" - 578 lb-ft.

Precision tripping torque ±3%

For more Torque Overload and Clutch Product Solutions

visit www.emerson-ept.com

Morse®

MZEU Series Cam Clutch

Features

- Full complement of cams
- Two bearings incorporated for concentricity control
- Symmetric, building block components
- Close tolerance outer diameter to mount sheave, gears, sprockets and torque arms

Bore range 0.472" - 5.0"

Torque range 44 - 25,000 lb-ft.



STANDARD TERMS AND CONDITIONS OF SALE (August 15, 2001)

These Terms and Conditions, the attendant quotation or acknowledgment and all documents incorporated by specific reference therein, will be the complete and exclusive statement of the terms of the agreement governing the sale of goods ("Goods") by **Emerson Power Transmission Corporation** and its divisions and subsidiaries ("Seller") to Customer ("Buyer"). Buyer's acceptance of the Goods will manifest Buyer's assent to these Terms and Conditions. If these Terms and Conditions differ in any way from the terms and conditions of Buyer's order, or other documentation, this document will be construed as a counteroffer and will not be deemed an acceptance of Buyer's terms and conditions which conflict herewith.

1. **PRICES:** Unless otherwise specified in writing by Seller, Seller's price for the goods shall remain in effect for thirty (30) days after the date of Seller's quotation or acknowledgment of Buyer's order for the Goods, whichever occurs first, provided an unconditional, complete authorization for the immediate shipment of the Goods is received and accepted by Seller within such time period. If such authorization is not received by Seller within such thirty (30) day period, Seller shall have the right to change the price for the Good to Seller's price for the Goods at the time of shipment.

2. **TAXES:** Any tax or governmental charge or increase in same hereafter becoming effective increasing the cost to Seller of producing, selling or delivering the Goods or of procuring material used therein, and any tax now in effect or increase in same payable by the Seller because of the manufacture, sale or delivery of the Goods, may at Seller's option, be added to the price.

3. **TERMS OF PAYMENT:** Subject to the approval of Seller's Credit Department, terms are net thirty (30) days from date of Seller's invoice in U.S. currency. If any payment owed to Seller is not paid when due, it shall bear interest, at a rate to be determined by Seller, which shall not exceed the maximum rate permitted by law, from the date on which it is due until it is paid. Seller shall have the right, among other remedies, either to terminate the Agreement or to suspend further performance under this and/or other agreements with Buyer in the event Buyer fails to make any payment when due. Buyer shall be liable for all expenses, including attorneys' fees, relating to the collection of past due amounts.

4. **SHIPMENT AND DELIVERY:** Shipments are made F.O.B. Seller's shipping point. Any claims for shortages or damages suffered in transit shall be submitted by the Buyer directly to the carrier. While Seller will use all reasonable commercial efforts to maintain the delivery date acknowledged or quoted by Seller, all shipping dates are approximate. Seller reserves the right to make partial shipments and to segregate "specials" and made-to-order Goods from normal stock Goods. Seller shall not be bound to tender delivery of any Goods for which Buyer has not provided shipping instructions.

5. **QUANTITY:** Buyer agrees to accept overruns of up to ten percent (10%) of the order on "made-to-order" Goods, including parts. Any such additional items shall be priced at the price per item charged for the specific quantity ordered.

6. **LIMITED WARRANTY:** Subject to the limitations of Section 7, Seller warrants that the Goods will be free from defects in material and workmanship under normal use, service and maintenance for a period of one year (unless otherwise specified by Seller in writing) from the date of shipment of the Goods by Seller. **THIS IS THE SOLE AND EXCLUSIVE WARRANTY GIVEN BY SELLER WITH RESPECT TO THE GOODS AND IS IN LIEU OF AND EXCLUDES ALL OTHER WARRANTIES, EXPRESS OR IMPLIED, ARISING BY OPERATION OF LAW OR OTHERWISE, INCLUDING WITHOUT LIMITATION, MERCHANTABILITY OR FITNESS FOR A PARTICULAR PURPOSE WHETHER OR NOT THE PURPOSE OR USE HAS BEEN DISCLOSED TO SELLER IN SPECIFICATIONS, DRAWINGS OR OTHERWISE, AND WHETHER OR NOT SELLER'S PRODUCTS ARE SPECIFICALLY DESIGNED AND/OR MANUFACTURED BY SELLER FOR BUYER'S USE OR PURPOSE.**

This warranty does not extend to any losses or damages due to misuse, accident, abuse, neglect, normal wear and tear, unauthorized modification or alteration, use beyond rated capacity, or improper installation, maintenance or application. To the extent that Buyer or its agents has supplied specifications, information, representation of operating conditions or other data to Seller in the selection or design of the Goods and the preparation of Seller's quotation, and in the event that actual operating conditions or other conditions differ from those represented by Buyer, any warranties or other provisions contained herein which are affected by such conditions shall be null and void. If within thirty (30) days after Buyer's discovery of any warranty defects within the warranty period, Buyer notifies Seller thereof in writing, Seller shall, at its option, repair or replace F.O.B. point of manufacture, or refund the purchase price for, that portion of the goods found by Seller to be defective. Failure by Buyer to give such written notice within the applicable time period shall be deemed an absolute and unconditional waiver of Buyer's claim for such defects. Goods repaired or replaced during the warranty period shall be covered by the foregoing warranty for the remainder of the original warranty period or ninety (90) days, whichever is longer. Buyer assumes all other responsibility for any loss, damage, or injury to persons or property arising out of, connected with, or resulting from the use of Goods, either alone or in combination with other products/components.

SECTIONS 6 AND 7 APPLY TO ANY ENTITY OR PERSON WHO MAY BUY, ACQUIRE OR USE SELLER'S GOODS, INCLUDING ANY ENTITY OR PERSON WHO BUYS THE GOODS FROM SELLER'S DISTRIBUTOR AND SUCH ENTITY OR PERSON SHALL BE BOUND BY THE LIMITATIONS THEREIN.

7. **LIMITATION OF REMEDY AND LIABILITY: THE SOLE AND EXCLUSIVE REMEDY FOR BREACH OF ANY WARRANTY HEREUNDER (OTHER THAN THE WARRANTY PROVIDED UNDER SECTION 13) SHALL BE LIMITED TO REPAIR, REPLACEMENT OR REFUND OF THE PURCHASE PRICE UNDER SECTION 6. SELLER SHALL NOT BE LIABLE FOR DAMAGES CAUSED BY DELAY IN PERFORMANCE AND IN NO EVENT, REGARDLESS OF THE FORM OF THE CLAIM OR CAUSE OF ACTION (WHETHER BASED IN CONTRACT, INFRINGEMENT, NEGLIGENCE, STRICT LIABILITY, OTHER TORT OR OTHERWISE), SHALL SELLER'S LIABILITY TO BUYER AND/OR ITS CUSTOMERS EXCEED THE PRICE TO BUYER OF THE SPECIFIC GOODS PROVIDED BY SELLER GIVING RISE TO THE CLAIM OR CAUSE OF ACTION. BUYER AGREES THAT IN NO EVENT SHALL SELLER'S LIABILITY TO BUYER AND/OR ITS CUSTOMERS EXTEND TO INCLUDE INCIDENTAL, CONSEQUENTIAL OR PUNITIVE DAMAGES. THE TERM "CONSEQUENTIAL DAMAGES" SHALL INCLUDE, BUT NOT BE LIMITED TO, LOSS OF**

ANTICIPATED PROFITS, LOSS OF USE, LOSS OF REVENUE, COST OF CAPITAL AND DAMAGE OR LOSS OF OTHER PROPERTY OR EQUIPMENT.

It is expressly understood that any technical advice furnished by Seller with respect to the use of the Goods is given without charge, and Seller assumes no obligation or liability for the advice given, or results obtained, all such advice being given and accepted at Buyer's risk.

GOODS AND/OR SERVICES SOLD HEREUNDER ARE NOT FOR USE IN ANY NUCLEAR AND RELATED APPLICATIONS. Buyer accepts goods and/or services with the foregoing understanding, agrees to communicate the same in writing to any subsequent purchaser or users and to defend, indemnify and hold harmless Seller from any claims, losses, suits, judgments and damages, including incidental and consequential damages, arising from such use, whether the cause of action be based in tort, contract or otherwise, including allegations that the Seller's liability is based on negligence or strict liability.

8. **EXCUSE OF PERFORMANCE:** Seller shall not be liable for delays in performance or for non-performance due to acts of God, acts of Buyer, war, riot, fire, flood, other severe weather, sabotage, or epidemics; strikes or labor disturbances; governmental requests, restrictions, laws, regulations, orders or actions; unavailability of or delays in transportation; default of suppliers; or unforeseen circumstances or any events or causes beyond Seller's reasonable control. Deliveries may be suspended for an appropriate period of time as a result of the foregoing. If Seller determines that its ability to supply the total demand for the Goods, or to obtain material used directly or indirectly in the manufacture of the Goods, is hindered, limited or made impracticable due to causes addressed in this Section 8, Seller may allocate its available supply of the Goods or such material (without obligation to acquire other supplies of any such Goods or material) among itself and its purchasers on such basis as Seller determines to be equitable without liability for any failure of performance which may result therefrom. Deliveries suspended or not made by reason of this section may be canceled by Seller upon notice to Buyer without liability, but the balance of the agreement shall otherwise remain unaffected.

9. **CANCELLATION:** The Buyer may cancel orders only upon written notice and upon payment to Seller of cancellation charges which include, among other things, all costs and expenses incurred and commitments made by the Seller and a reasonable profit thereon.

10. **CHANGES:** Buyer may request changes or additions to the Goods consistent with Seller's specifications and criteria. In the event such changes or additions are accepted by Seller, Seller may revise the price and delivery schedule. Seller reserves the right to change designs and specifications for the Goods without prior notice to Buyer, except with respect to Goods being made-to-order for Buyer.

11. **TOOLING:** Tool, die, and pattern charges, if any, are in addition to the price of the Goods and are due and payable upon completion of the tooling. All such tools, dies and patterns shall be and remain the property of Seller. Charges for tools, dies, and patterns do not convey to Buyer, title, ownership interests in, or rights to possession or removal, nor prevent their use by Seller for other purchasers, except as otherwise expressly provided by Seller and Buyer in writing with reference to this provision.

12. **ASSIGNMENT:** Buyer shall not assign its rights or delegate its duties hereunder or any interest therein or any rights hereunder without the prior written consent of the Seller, and any such assignment, without such consent, shall be void.

13. **PATENTS AND COPYRIGHTS:** Subject to Section 7, Seller warrants that the Goods sold, except as are made specifically for Buyer according to Buyer's specifications, do not infringe any valid U.S. patent or copyright in existence as of the date of delivery. This warranty is given upon the condition that Buyer promptly notify Seller of any claim or suit involving Buyer in which such infringement is alleged, and, that Buyer cooperate fully with Seller and permit Seller to control completely the defense or compromise of any such allegation of infringement. Seller's warranty as to use only applies to infringements arising solely out of the inherent operation (i) of such Goods, or (ii) of any combination of Goods in a system designed by Seller. In the event such Goods, singularly or in combination, are held to infringe a U.S. patent or copyright in such suit, and the use of such Goods is enjoined, or in the case of a compromise by Seller, Seller shall have the right, at its option and expense, to procure for Buyer the right to continue using such Goods, or replace them with non-infringing Goods; or modify same to become non-infringing; or grant Buyer a credit for the depreciated value of such Goods and accept return of them.

14. **MISCELLANEOUS:** These terms and conditions set forth the entire understanding and agreement between Seller and Buyer, and supersede all other communications, negotiations and prior oral or written statements regarding the subject matter of these terms and conditions. No change, modification, rescission, discharge, abandonment, or waiver of these terms and conditions of Sale shall be binding upon the Seller unless made in writing and signed on its behalf by an officer of the Seller. No conditions, usage or trade, course of dealing or performance, understanding or agreement purporting to modify, vary, explain, or supplement these Terms and Conditions shall be binding unless hereafter made in writing and signed by the party to be bound, and no modification shall be affected by the acceptance of purchase orders or shipping instruction forms containing terms at variance with or in addition to those set forth herein. Any such modifications or additional terms are specifically rejected by Seller. No waiver by Seller with respect to any breach or default or any right or remedy and no course of dealing, shall be deemed to constitute a continuing waiver of any other breach or default or of any other right or remedy, unless such waiver be expressed in writing and signed by the party to be bound. Seller is not responsible for typographical or clerical errors made in any quotation, orders or publications. All such errors are subject to correction. The validity, performance, and all other matters relating to the interpretation and effect of this contract shall be governed by the law of the state of New York. The United Nations Convention on the International Sale of Goods shall not apply to any transaction hereunder.



Browning

Helical Speed
Reducers & Gearmotors



SEALMASTER

Mounted Ball Bearings



Morse

Clutches



Browning

Shaft Mount Reducers

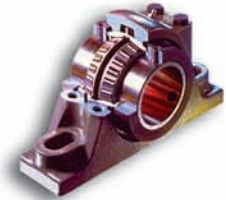

SEALMASTER

Mounted Roller Bearings



ROLLWAY

Roller Bearings



Browning

V-Belt Drives



Morse

Chain



KOP-FLEX

Couplings



Browning

MXP Motorized Pulleys



Morse

Worm Gearing



McGILL

Precision Bearings

www.emerson-ept.com

Emerson Power Transmission Customer Service

Telephone 1-800-626-2120

Fax 1-800-262-3292

Emerson Power Transmission
Maysville, KY 41056
Telephone 606-564-2011
Fax 606-564-2052

Emerson Power Transmission
7120 New Buffington Rd.
P.O. Box 728
Florence, KY 41022
Telephone 859-342-7900
Fax 859-342-5652

Emerson Power Transmission – West
3553 Placentia Ct.
Chino, CA 91710
Telephone 909-591-9561
Fax 909-628-1983

Emerson Power Transmission – Export
7120 New Buffington Rd.
Florence, KY 41042
Telephone 859-727-5273
Fax 859-727-0721

Emerson Power Transmission – Canada
16 Main Street
Unionville, ONT L3R 2E4
Telephone 905-294-9330
1-800-268-4149
Fax 1-800-668-9005

Kop-Flex, Inc.
P. O. Box 1696
Baltimore, MD 21203
Telephone Plant 410-768-2000
Fax 410-787-8424

Kop-Flex Canada, Ltd.
19 Meteor Drive
Rexdale, ONT M9W 1A3
Telephone 416-675-7144
Fax 416-675-6764

McGill Manufacturing Co., Inc.
909 North Lafayette St.
Valparaiso, IN 46383
Aerospace Bearings Telephone 219-465-2200
Aerospace Bearings Fax 219-465-2290

Catalog CRES-07

Form #9027 • 1/07 • 15M • Printed in U.S.

APPLICATION CONSIDERATIONS

The proper selection and application of power transmission products and components, including the related area of product safety, is the responsibility of the customer. Operating and performance requirements and potential associated issues will vary appreciably depending upon the use and application of such products and components. The scope of the technical and application information included in this publication is necessarily limited. Unusual operating environments and conditions, lubrication requirements, loading supports, and other factors can materially affect the application and operating results of the products and components and the customer should carefully review its requirements. Any technical advice or review furnished by Emerson Power Transmission Corporation and its divisions with respect to the use of products and components is given in good faith and without charge, and Emerson assumes no obligation or liability for the advice given, or results obtained, all such advice and review being given and accepted at customer's risk.

For a copy of our Standard Terms and Conditions of Sale, Disclaimers of Warranty, Limitation of Liability and Remedy, please contact Emerson Power Transmission Customer Service at 1-800-626-2120. These terms and conditions of sale, disclaimers and limitations of liability apply to any person who may buy, acquire or use an Emerson Power Transmission Corporation product referred to herein, including any person who buys from a licensed distributor of these branded products.