

MCGILL.
Metric Camrol®
Bearings



EMERSON. CONSIDER IT SOLVED.™

McGILL®

CAMROL® – the original Cam Follower Bearing,

CAMROL is the trademark for the line of roller bearing cam followers manufactured by McGill and designed for use as cam followers and track rollers. The CAMROL Cam Follower Bearing was originally invented by McGill over 60 years ago. Since then, McGill has maintained its leading position through the continuous development of new features and improvements to the line.

McGill has worked closely with its customers to serve global needs of industry with a complete series of Metric Cam Followers. The McGill standard Metric CAMROL is manufactured to ISO standards and Asian designs. The metric stud type MCF and cam yoke roller MCYR share all the same high-quality features as other CAMROL Bearings. Each Cam Follower is supplied with two nuts and appropriate metric threads; the second nut is intended to serve as a locknut. All designs use the patented LUBRI-DISC® Seals that provide positive protection against contamination and loss of lubricant. LUBRI-DISC Seals reduce internal bearing friction – bearings wear less and last longer.

MCF Series

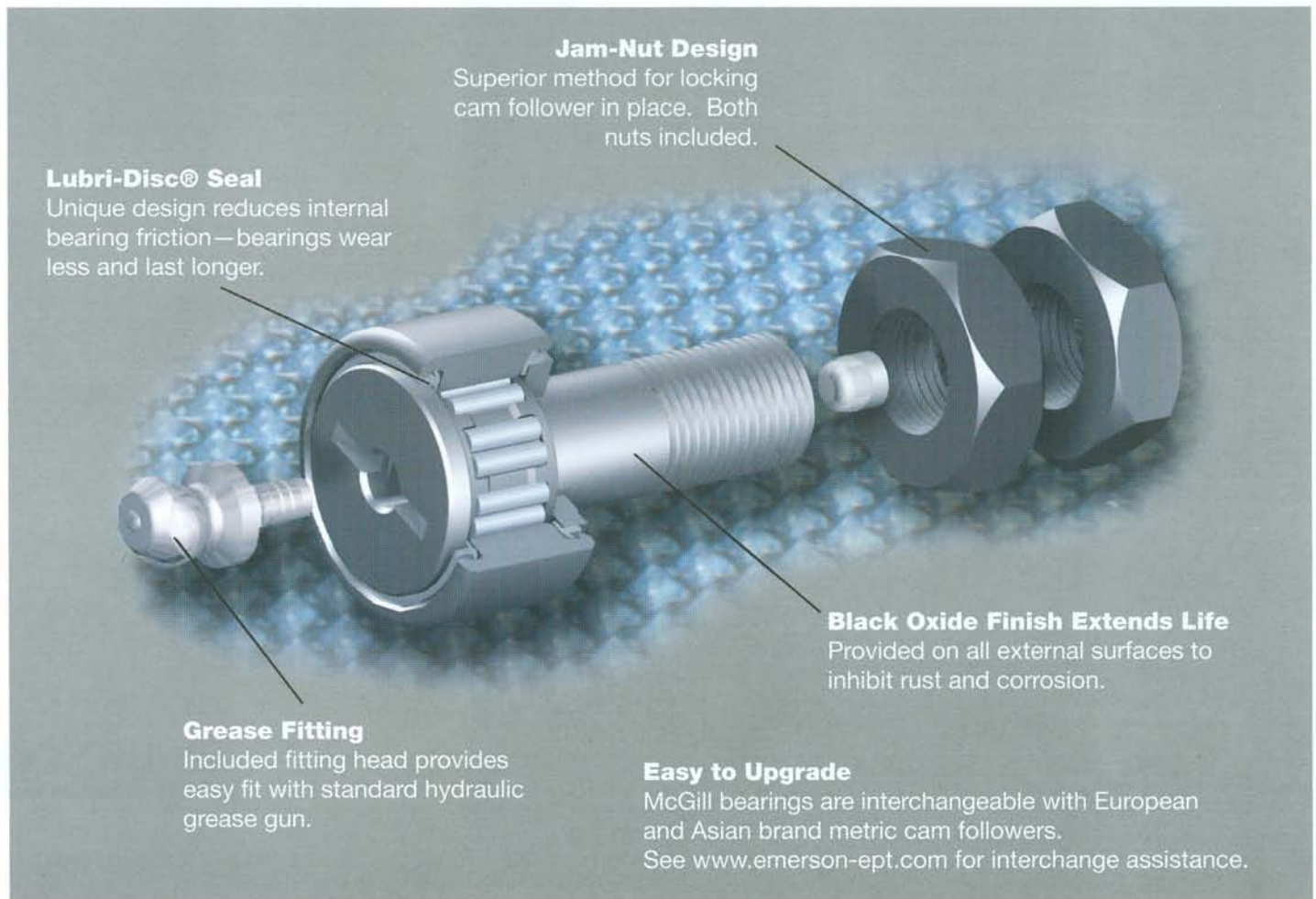

invented by McGill over 70 years ago.

MCFD Series

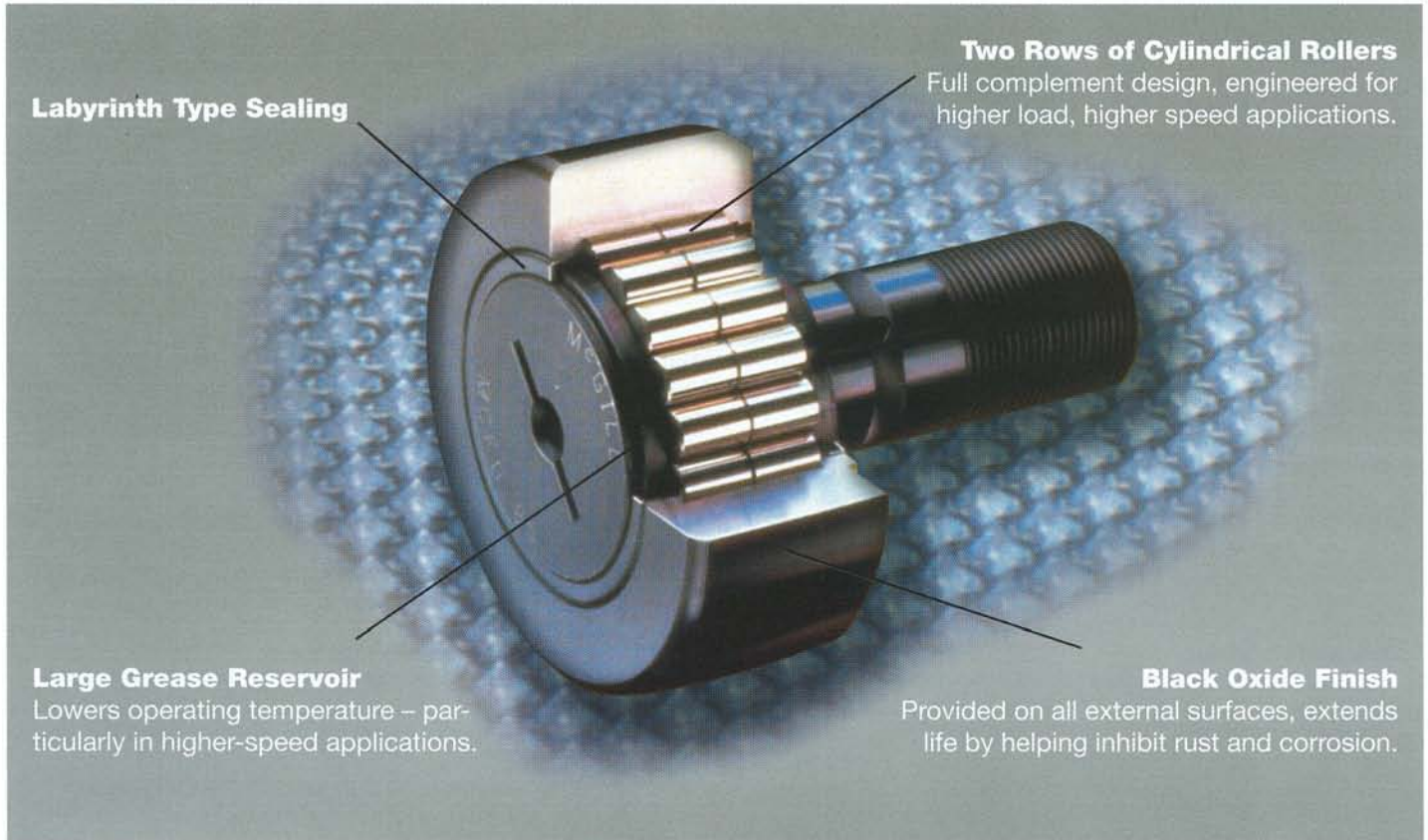

Contents	Page
Engineering Data	2
MCF Series - Needle Rollers/Stud Type.....	8
MCYR Series - Needle Rollers/Yoke Type.....	10
MCFD Series - Cylindrical Rollers/Stud Type.....	12
MCYRD Series - Cylindrical Rollers/Yoke Type.....	13
Eccentric Collar CAMROL Bearings.....	14
Interchangeability Charts	15

METRIC CAMROL Bearings

McGill offers METRIC CAMROL Bearings in metric dimensions equivalent to the ISO standard series. Both European and Asian versions are available.



Stud Type



Yoke Type

McGill METRIC CAMROL Bearings are available in stud or yoke type versions. Specifying the yoke type or stud type bearing will depend on the preference for either a straddle (yoke) mounting or a cantilever (overhung) mounting.

Standard Features:

- Outer rings with a large radial cross section to withstand bending stresses that result from heavy rolling or shock loads.
- Black oxide finish on all exposed surfaces helps prevent corrosion.
- All bearings are available with a cylindrical outside diameter or the standard 500mm crown radius.
- Integral studs on MCF, MCFR and MCFD cam followers are designed for cantilever mounting. Extended end of the inner stud has metric threads. The screw-driver slot (or optional broach slot) on the flange is used to hold the stud stationary while tightening the nuts during mounting.
- Metric stud type cam followers include two metric nuts and a lubrication fitting. The second nut serves as a locknut. (See page 2.)

McGill METRIC CAMROL Bearings are available with three types of internal construction: full complement needle rollers, retainer type needle rollers or cylindrical rollers.

Load Ratings

The basic load rating or basic dynamic rating, as defined by ABMA and ISO, is that calculated, constant radial load which 90% of a group of apparently identical bearings with stationary outer ring can theoretically endure for a rating life of 1,000,000 revolutions (33 1/3 rpm for 500 hours). The basic load rating is a reference value only, the base value of 1,000,000 revolutions chosen for ease of calculation.

The dimensional tables list the Basic Dynamic (C) and Basic Static (Co) Load Ratings as calculated by the ISO and ABMA standards. Also listed are the dynamic and static ratings for the CAMROL Bearings operating as track rollers.

These dynamic and static ratings are less than those calculated by the basic load rating formulas (C and Co) and account for the additional bending stresses present because the outer ring is unsupported. The load applied on the bearing while it is operating dynamically should not exceed 50% of the dynamic rating as a track roller.

Bearing Life

Statistical L_{10} bearing fatigue life can be calculated according to the following formula:

$$L_{10} \text{ life in hours} = \frac{16666}{N} \times \left(\frac{\text{BDR}}{P} \right)^{10/3}$$

Where:

- BDR = Basic Dynamic Rating (Newtons)
- P = Radial Load (Newtons)
- N = Speed (RPM)
- L_{10} = Fatigue Life (Hours)

To determine the basic dynamic rating required for a given application, use the following formula:

$$\text{BDR} = .054 \times P \times (L_{10} \times N)^3$$

Mounting

The following should be considered in mounting CAMROL Bearings:

- The housing that supports the cam follower stud (or the shaft on which the cam yoke roller is mounted) should be of sufficient strength to resist excessive deformation under the expected applied load.
- The face of the housing should be flat and square with the housing bore, and must have a diameter of at least that listed in the dimensional tables for proper support of the bearing endplate.
- In order to obtain the best support for the CAMROL Bearing, the chamfer on the housing bore should not exceed 0.5 mm x 45°.
- When mounting stud type CAMROL Bearings in a machine member, the radial lubrication hole (it is in line with the McGill name) should be located in the unloaded portion of the raceway.
- Any pressure required for installation should be applied against the solid center portion of the flanged inner stud (not on the flange perimeter), and the cam follower should be drawn up tightly by the nut so the bearing endplate is securely backed up.
- Precaution should be taken to avoid excessive torque when tightening the clamping nut; otherwise undue stress may be set up in the stud.
- The clamping nut should not be tightened beyond the maximum clamping torque listed in the dimensional table.

- Yoke type CAMROL Bearings should be mounted with the lubrication hole in the unloaded portion of the raceway and according to the recommended shaft dimensions listed in the tabular data.
- When a tight fit of the bearing on a shaft is desired, an ISO j6 shaft tolerance should be employed. For heavily loaded applications, the bearing should be clamped endwise and mounted on a high strength shaft with an ISO j6 tolerance.
- If the bearing cannot be clamped endwise, it is essential to have a close axial fit in the yoke in which the bearing is mounted to prevent axial displacement of the endplates under load.

Lubrication

All McGill CAMROL Bearings are supplied prelubricated with a high grade lithium base grease having an operating temperature range of -29°C to +120°C (-20°F to +248°F) and frequent relubrication is suggested for continuous rotating applications.

Provision for Relubrication - Stud Type

Stud type CAMROL Bearings have provision for relubrication either through the end of the inner stud or through a cross drilled hole in the stud shank.

Sizes up through 19mm OD do not have an axial hole from the threaded end, and no cross drill hole is present in the stud shank on sizes through 26mm OD. The counterbored ends of the axial holes are designed to accept a press-fitted type metric lubrication fitting. Closing plugs are supplied so that the unused axial hole or holes can be sealed. If the cross-drilled hole is not used for relubrication, it should be covered by the housing; therefore, no plug is supplied for this hole.

Provision for Relubrication - Yoke Type

Yoke type CAMROL Bearings have a lubrication hole in the inner ring bore so relubrication can be accomplished through a cross-drilled hole in the supporting shaft if desired.

Track Design

Since cam followers or cam yoke rollers are merely one component of a two-piece bearing construction, along with the track or cam on which it operates, proper selection of the track or cam material must be considered. This selection has a direct effect upon ultimate life and performance of the cam roll application.

Where bearings are used as support or guide rollers, it is often difficult to obtain high hardness and tensile strength values for the machine members against which the bearings operate. In the interest of economy, relatively soft structural materials can be applied in most applications where dimensional accuracy is not extremely critical. The work hardening of ferrous, low carbon track materials, accompanied by relatively small amounts of wear-in of the bearing into the track surface, generally results in satisfactory bearing performance. In the application of cam follower or cam yoke roller bearings (lift truck mast rollers, for instance), it is common to employ formed structural steel sections as bearing track support members, and the wearing-in and work hardening of the track surface generally results in a satisfactory bearing application, providing loads are not excessive.

Cam Design

Cam applications are similar in many respects to track or support roller applications, except that bearing speeds are higher due to the multiplication of cam revolutions per minute by the ratio of the cam OD to the cam follower OD. Because of these higher speeds, oil lubrication is preferred, but where such lubrication methods are not possible, grease should be replaced frequently.

In the application of box or drum cams, it is possible to obtain differential rotation of the cam follower outer race as well as associated load reversals. This may result in excessive wear of cams or cam followers unless proper cam hardness and materials are employed, as well as ample lubrication. In box cams of this nature, the cam rise and cam fall should be watched closely, since the load reversal encountered can cause shock loads in excess of the capacity of the stud or bearing.

The same precaution applies to ordinary circular cams. Instantaneous loads due to rapid cam rise should be carefully calculated and kept below the ultimate strength of the follower and the stud.

In ordinary cam design it is possible to employ the most efficient materials for best resistance to fatigue and brinelling, and attainment of high track surface hardnesses associated with good wear resistance is quite feasible. The same general precautions concerning tensile strength, as listed under track design above, should be followed for cam design; applications involving high marginal bearing or cam loading should be referred to the McGill Engineering Department.

Track Capacity

Track capacity of all cam follower and cam yoke roller bearings is the load which a steel track of a given tensile strength will withstand continuously without deformation or brinelling. Table II lists track capacities for steel tracks for the standard crowned roller outside diameter versions. For the straight cylindrical roller outside diameter versions ("-X" suffix), multiply by 1.25 to obtain the track capacity ratings.

To obtain track capacities for track hardnesses other than Rockwell "C" scale 40 (tensile strength 1242 MPa), multiply track capacity by track capacity factor listed in Table I. Regardless of track capacity, dynamic load should not exceed 50% of basic dynamic rating as a track roller and static load should not exceed maximum static rating as a track roller.

Table I - Track Tensile Strength

MPa	TRACK HARDNESS ROCKWELL "C"	TRACK CAPACITY FACTOR
828	26	.445
966	32	.667
1104	36	.792
1242	40	1.000
1380	44	1.237
1518	47	1.495
1656	50	1.775
1794	53	2.090
1932	56	2.420
2070	58	2.780

Table II - Track Capacities

BASIC BEARING NUMBER	TRACK CAPACITY NEWTONS	BASIC BEARING NUMBER	TRACK CAPACITY NEWTONS
MCFR-13	1910	MCFR-52	19200
MCFR-16	2940	MCYRR-25	19200
MCYRR-5	2940	MCFD-52	19200
MCFR-19	3490	MCYRD-25	19200
MCYRR-6	3490	MCFR-62	28400
MCFR-22	4270	MCYRR-30	27400
MCYRR-8	5500	MCFD-62	28400
MCFR-26	5050	MCYRD-30	27400
MCFR-30	6350	MCFR-72	31800
MCYRR-10	6350	MCYRR-35	30500
MCFR-32	6780	MCFD-72	31800
MCYRR-12	6780	MCYRD-35	30500
MCFR-35	9840	MCFR-80	43800
MCYRR-15	9840	MCYRR-40	36700
MCFD-35	9840	MCFD-80	43800
MCYRD-15	9840	MCYRD-40	36700
MCFR-40	12000	MCFR-85	46400
MCYRR-17	12000	MCYRR-45	39000
MCFD-40	12000	MCYRD-45	39000
MCYRD-17	12000	MCFR-90	49200
MCFR-47	17400	MCYRR-50	41300
MCYRR-20	17400	MCFD-90	49200
MCFD-47	17400	MCYRD-50	41300
MCYRD-20	17400		

From an application standpoint, cam follower and cam yoke roller-type bearings may be mounted interchangeably. The selection depends upon the mounting preference:

- Straddle or yoke mounting — requires the use of a cam yoke roller bearing
- Cantilever or overhung mounting — requires use of the stud mounted cam follower

In general, heavier loads can be supported by the cam yoke roller bearing where the yoke mounting arrangement is possible — since the problem of stud deflection is eliminated, and the ultimate shear strength of the pin on which the cam yoke bearing is mounted becomes the governing factor from a load-carrying standpoint. In most cases, the cam follower construction is preferred because of its simpler mounting: the user needs only to drill and ream a suitable mounting hole in the support housing. Both cam followers and cam yoke rollers offer a low-cost, readily available, easily mounted bearing for follower arms, guide rollers, table support bearings and many other applications — involving either linear movement or the translation of rotary motion to axial motion. Due to the accuracy of manufacture, bearings can easily be mounted in multiples, providing hole locations are maintained for table support rollers with resultant adequate load sharing properties. Where greater accuracy is required, it is possible to select catalog bearings to closer control limits; and where accuracy of mounting is needed, it is possible to mount the cam follower stud in an auxiliary eccentric collar, which in turn is mounted in the support member. With this modification, the ultimate in accurate load sharing capabilities is gained in multiple bearing arrangements.

CAMROL Bearing Application Engineering

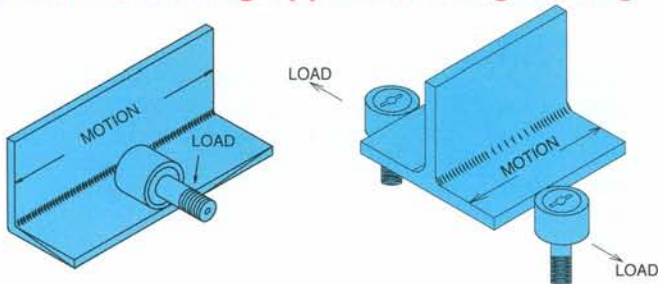

Track or load support rollers to provide anti-friction linear motion.

Track guide rollers — to insure free and accurate lateral location during linear motion.

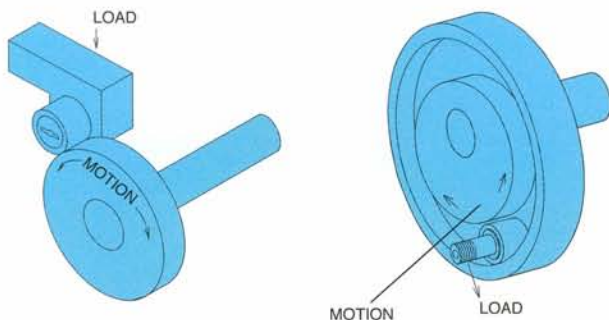

External cam applications — precise, anti-friction translation of motion.

Internal cam applications.

Yoke Mounting

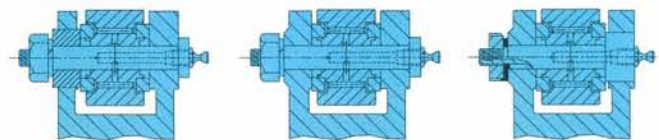

In the application of cam yoke roller bearings, several mounting arrangements are possible, and three of these are shown above for MCYR bearings. These mountings are straight-forward and show the bearings clamped endwise in each case. It is possible to apply bearings of this type without resorting to endwise clamping; however endwise clearance over the endplate should be controlled closely to avoid disassembly of the bearing.



Metric stud type CAMROL Bearings are available with a hexagonal hole in the face of the stud in place of the screwdriver slot. This feature is advantageous for mounting bearings in blind holes or with self-locking nuts requiring greater-than-average thread torque. In this modification, relubrication through the flange end of the stud is not possible.

Hexagonal Wrench Sizes

BASIC BEARING NUMBER	HEX WRENCH SIZE, MM	BASIC BEARING NUMBER	HEX WRENCH SIZE, MM
13	3	47	10
16	4	47A	10
19	4	52	10
22	4	52A	10
22A	5	62	14
26	4	62A	14
26A	5	72	14
30	6	72A	14
32	6	80	14
35	8	85	14
40	8	90	14
40A	8		

Eccentric Collar CAMROL Bearings



The eccentric collar feature provides an easy means of radial adjustment for precise positioning of cam followers, track, guide and support rollers. In-line combinations of eccentric collar CAMROL Bearings can be perfectly aligned without the need for extremely close tolerances of mounting holes and members. Problems involving control of clearances, pre-loading and compensation for wear can be avoided or solved by the easy adjustment of new bearings.

In most applications, a lock nut is sufficient to hold the bearing at the desired position. In applications where a more positive means of holding a given position is required, this can be accomplished by drilling and doweling through the housing into the bushing and the stud.

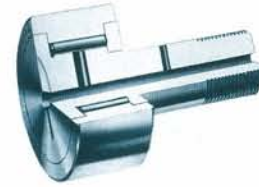

Stud Type

SERIES	CONSTRUCTION FEATURES
MCF	Full complement of needle rollers
MCFE	With eccentric collar
MCF-X	With cylindrical outside diameter
MCF-B, MCF-BX	With hexagonal hole
MCF-S, MCF-SBX	With seals
MCFR	Caged needle rollers
MCFRE	With eccentric collar
MCFR-X	With cylindrical outside diameter
MCFR-B, MCFR-BX	With hexagonal hole
MCFR-S, MCFR-SBX	With seals
MCFD	Full complement cylindrical rollers
MCFDE	With eccentric collar
MCFD-X	With cylindrical outside diameter



Yoke Type

SERIES	CONSTRUCTION FEATURES
MCYR	Full complement of needle rollers
MCYR-S	With seals
MCYR-X	With cylindrical outside diameter
MCYR-SX	With cylindrical outside diameter
MCYRR	Caged needle rollers
MCYRR-S	With seals
MCYRR-SX	With cylindrical outside diameter
MCYRD	Full complement cylindrical rollers
MCYRD-X	With cylindrical outside diameter

MCF SERIES

STUD TYPE

- Series MCF — Unsealed, full complement
- Series MCF-S — Sealed, full complement
- Series MCFR — Unsealed, cage type
- Series MCFR-S — Sealed, cage type



MCF

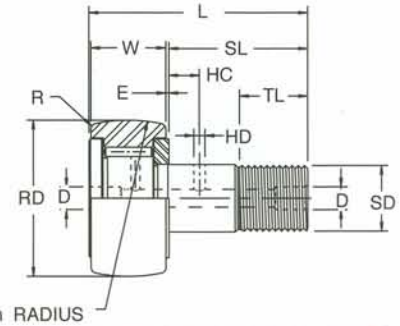

UNSEALED BRG. NO. (1)	SEALED BRG. NO. (1)	ROLLER DIA. RD NOM. (2)	ROLLER WIDTH W +0.00 -0.12	STUD DIA. SD NOM. (3)	STUD L'GTH. SL NOM.	OVERALL LENGTH L NOM.	ENDPLATE EXTENSION E NOM.	THREAD	THREAD LENGTH TL NOM.	OIL HOLE	
										(HC) NOM.	(HD) NOM.
		mm	mm	mm	mm	mm	mm	mm	mm	mm	
MCFR-13	MCFR-13-S	13	9	5	13	23	0.6	M5x0.8	7.5	-	-
MCFR-16 MCF-16	MCFR-16-S MCF-16-S	16	11	6	16	28	0.6	M6x1	9	-	-
MCFR-19 MCF-19	MCFR-19-S MCF-19-S	19	11	8	20	32	0.6	M8x1.25	11	-	-
MCFR-22 MCF-22	MCFR-22-S MCF-22-S	22	12	10	23	36	0.6	M10x1	12	-	-
MCFR-22A MCF-22A	MCFR-22A-S MCF-22A-S	22	12	10	23	36	0.6	M10x1.25	13	-	-
MCFR-26 MCF-26	MCFR-26-S MCF-26-S	26	12	10	23	36	0.6	M10x1	12	-	-
MCFR-26A MCF-26A	MCFR-26A-S MCF-26A-S	26	12	10	23	36	0.6	M10x1.25	13	-	-
MCFR-30 MCF-30	MCFR-30-S MCF-30-S	30	14	12	25	40	0.6	M12x1.5	14	6	3
MCFR-32 MCF-32	MCFR-32-S MCF-32-S	32	14	12	25	40	0.6	M12x1.5	14	6	3
MCFR-35 MCF-35	MCFR-35-S MCF-35-S	35	18	16	32.5	52	0.8	M16x1.5	18	8	3
MCFR-40 MCF-40	MCFR-40-S MCF-40-S	40	20	18	36.5	58	0.8	M18x1.5	19	8	3
MCFR-40A MCF-40A	MCFR-40A-S MCF-40A-S	40	20	18	36.5	58	0.8	M18x1.5	20	10	3
MCFR-47 MCF-47	MCFR-47-S MCF-47-S	47	24	20	40.5	66	0.8	M20x1.5	21	9	4
MCFR-47A MCF-47A	MCFR-47A-S MCF-47A-S	47	24	20	40.5	66	0.8	M20x1.5	22	12	4
MCFR-52 MCF-52	MCFR-52-S MCF-52-S	52	24	20	40.5	66	0.8	M20x1.5	21	9	4
MCFR-52A MCF-52A	MCFR-52A-S MCF-52A-S	52	24	20	40.5	66	0.8	M20x1.5	22	12	4
MCFR-62 MCF-62	MCFR-62-S MCF-62-S	62	29	24	49.5	80	0.8	M24x1.5	25	11	4
MCFR-62A MCF-62A	MCFR-62A-S MCF-62A-S	62	29	24	49.5	80	0.8	M24x1.5	25	12	4
MCFR-72 MCF-72	MCFR-72-S MCF-72-S	72	29	24	49.5	80	0.8	M24x1.5	25	11	4
MCFR-72A MCF-72A	MCFR-72A-S MCF-72A-S	72	29	24	49.5	80	0.8	M24x1.5	25	12	4
MCFR-80 MCF-80	MCFR-80-S MCF-80-S	80	35	30	63	100	1	M30x1.5	32	15	4
MCFR-85 MCF-85	MCFR-85-S MCF-85-S	85	35	30	63	100	1	M30x1.5	32	15	4
MCFR-90 MCF-90	MCFR-90-S MCF-90-S	90	35	30	63	100	1	M30x1.5	32	15	4

(1) Standard bearing has a crowned roller outside diameter. For straight cylindrical outside roller diameter, add suffix "X". Example - MCFR-35-X or MCF-35-SX
 (2) Tolerance limits for Roller Diameter are shown below.

Cylindrical Roller Dia. "RD"

RD (NOM.)		TOLERANCE	
OVER	INCL.	MAX.	MIN.
mm	mm	mm	mm
6	18	0	-0.008
18	30	0	-0.009
30	50	0	-0.011
50	80	0	-0.013
80	120	0	-0.015

Crowned Roller Dia. "RD"

RD (NOM.)		TOLERANCE	
OVER	INCL.	MAX.	MIN.
mm	mm	mm	mm
6	120	0	-0.050

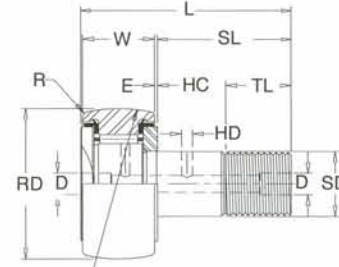
MCFR-S

500mm RADIUS

UNSEALED BRG. NO. (1)	SEALED BRG. NO. (1)	REAMED HOLE D NOM. (mm)	CORNER RADIUS R (mm)	CLAMPING DIA. MIN. (mm)	CLAMPING TORQUE MAX (4) (Nm)	LIMITING SPEED (7)		HOUSING BORE DIA. (mm)		ISO/ABMA BASIC LOAD RATINGS NEWTONS		TRACK ROLLER LOAD RATINGS NEWTONS		MASS (kg)
						GREASE (rpm)	OIL (rpm)	MIN.	MAX.	DYNAMIC	STATIC	DYNAMIC (6)	STATIC (5)	
MCFR-13	MCFR-13-S	3.1*	0.3	9	2.2	20000	30000	5.000	5.012	2450	2260	2060	1650	0.010
MCFR-16	MCFR-16-S	4†*	0.3	11	3	19500	25000	6.000	6.012	4120	4120	3430	2350	0.018
MCF-16	MCF-16-S					13000	17000			6960	8340	5790	2350	0.019
MCFR-19	MCFR-19-S	4†*	0.3	13	8	15500	20000	8.000	8.015	4510	5000	3730	4140	0.028
MCF-19	MCF-19-S					10500	13500			8040	10490	6670	5100	0.029
MCFR-22	MCFR-22-S	4	0.5	15	15	13500	17500	10.000	10.015	6280	7260	5200	6050	0.043
MCF-22	MCF-22-S					9000	11500			9410	12360	7850	10400	0.044
MCFR-22A	MCFR-22A-S	4	0.5	15	15	13500	17500	10.000	10.015	6280	7260	5200	6050	0.043
MCF-22A	MCF-22A-S					9000	11500			9410	12360	7850	10400	0.044
MCFR-26	MCFR-26-S	4	0.5	15	15	13500	17500	10.000	10.015	6280	7260	5200	6050	0.055
MCF-26	MCF-26-S					9000	11500			9410	12360	7850	10400	0.056
MCFR-26A	MCFR-26A-S	4	0.5	15	15	13500	17500	10.000	10.015	6280	7260	5200	6050	0.055
MCF-26A	MCF-26A-S					9000	11500			9410	12360	7850	10400	0.056
MCFR-30	MCFR-30-S	6	1	19	22	9600	12500	12.000	12.018	8240	9710	6860	8050	0.087
MCF-30	MCF-30-S					6400	8300			13240	18140	11080	15300	0.089
MCFR-32	MCFR-32-S	6	1	19	22	9600	12500	12.000	12.018	8240	9710	6860	8050	0.096
MCF-32	MCF-32-S					6400	8300			13240	18140	11080	15300	0.099
MCFR-35	MCFR-35-S	6	1	24	57	6300	8000	16.000	16.018	13040	19030	10890	15900	0.166
MCF-35	MCF-35-S					4200	5500			20300	34130	16970	28500	0.171
MCFR-40	MCFR-40-S	6	1.5	27	85	5000	6400	18.000	18.018	15990	23730	13340	19800	0.245
MCF-40	MCF-40-S					3300	4300			23240	38540	19420	32200	0.248
MCFR-40A	MCFR-40A-S	6	1.5	27	85	5000	6400	18.000	18.018	15990	23730	13340	19800	0.245
MCF-40A	MCF-40A-S					3300	4300			23240	38540	19420	32200	0.248
MCFR-47	MCFR-47-S	8	1.5	30	118	3900	5000	20.000	20.021	21280	35700	17750	29800	0.387
MCF-47	MCF-47-S					2600	3400			30790	57670	25690	46700	0.393
MCFR-47A	MCFR-47A-S	8	1.5	30	118	3900	5000	20.000	20.021	21280	35700	17750	29800	0.387
MCF-47A	MCF-47A-S					2600	3400			30790	57670	25690	46700	0.393
MCFR-52	MCFR-52-S	8	1.5	30	118	3900	5000	20.000	20.021	21280	35700	17750	29800	0.453
MCF-52	MCF-52-S					2600	3400			30790	57670	25690	46700	0.455
MCFR-52A	MCFR-52A-S	8	1.5	30	118	3900	5000	20.000	20.021	21280	35700	17750	29800	0.453
MCF-52A	MCF-52A-S					2600	3400			30790	57670	25690	46700	0.455
MCFR-62	MCFR-62-S	8	1.5	38	216	3100	4100	24.000	24.021	31680	55700	26380	46300	0.801
MCF-62	MCF-62-S					2100	2700			46580	92630	38840	65400	0.810
MCFR-62A	MCFR-62A-S	8	1.5	38	216	3100	4100	24.000	24.021	31680	55700	26380	46300	0.801
MCF-62A	MCF-62A-S					2100	2700			46580	92680	38840	65400	0.810
MCFR-72	MCFR-72-S	8	2	38	216	3100	4100	24.000	24.021	31680	55700	26380	46300	1.039
MCF-72	MCF-72-S					2100	2700			46580	92680	38840	65400	1.048
MCFR-72A	MCFR-72A-S	8	2	38	216	3100	4100	24.000	24.021	31680	55700	26380	46300	1.039
MCF-72A	MCF-72A-S					2100	2700			46580	92680	38840	65400	1.048
MCFR-80	MCFR-80-S	8	2	51	441	2200	2900	30.000	30.021	56000	105030	46680	87600	1.621
MCF-80	MCF-80-S					1500	2000			76980	159850	64140	102300	1.642
MCFR-85	MCFR-85-S	8	2	51	441	2200	2900	30.000	30.021	56000	105030	46680	87600	1.793
MCF-85	MCF-85-S					1500	2000			76980	159850	64140	102300	1.814
MCFR-90	MCFR-90-S	8	2	51	441	2200	2900	30.000	30.021	56000	105030	46680	87600	1.981
MCF-90	MCF-90-S					1500	2000			76980	159850	64140	102300	2.002

(3) Stud Diameter "SD" per ISO tolerance h7, shown below.

Stud Dia. "SD"

SD (NOM.)		TOLERANCE	
OVER	INCL.	MAX.	MIN.
mm	mm	mm	mm
2	6	0	-0.012
6	10	0	-0.015
10	18	0	-0.018
18	30	0	-0.021

- (4) Clamping torque is based on dry threads. If threads are lubricated, use half of value shown.
- (5) Static load rating is based on stud strength or on internal rolling element load distribution stresses.
- (6) Dynamic load should not exceed 50% of Dynamic Rating as a track roller.
- (7) Since load, lubrication method, temperature and other factors affect the maximum operating speed, it is impossible to determine precise limiting speed. The listed limiting speeds are based on lightly loaded bearings having adequate lubrication and are listed only as a design guide. More frequent relubrication is required when operating at higher speeds. Actual bearing testing in the specific application should be conducted if the anticipated operating speed approaches the listed limiting speed.
- Sizes marked have no lube holes in threaded end of stud.

MCYR SERIES

YOKE TYPE

- Series MCYR — Unsealed, full complement
- Series MCYR-S — Sealed, full complement
- Series MCYRR — Unsealed, cage type
- Series MCYRR-S — Sealed, cage type



MCYR

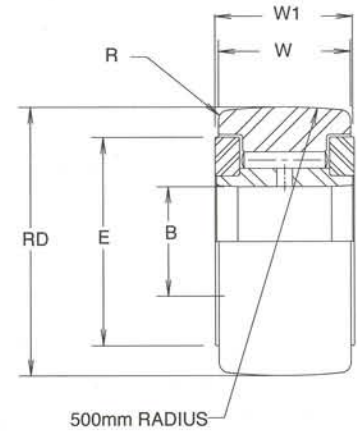

UNSEALED BEARING NUMBER (1)	SEALED BEARING NUMBER (1)	BEARING DIMENSIONS						
		BORE DIA. B		ROLLER DIA. RD NOM. (2)	ROLLER WIDTH W	WIDTH W1		CORNER RADIUS R
		MAX.	MIN.			MAX.	MIN.	
		mm	mm			mm	mm	
MCYRR-5 MCYR-5	MCYRR-5-S MCYR-5-S	5	4.992	16	11	12	11.82	0.3
MCYRR-6 MCYR-6	MCYRR-6-S MCYR-6-S	6	5.992	19	11	12	11.82	0.3
MCYRR-8 MCYR-8	MCYRR-8-S MCYR-8-S	8	7.992	24	14	15	14.82	0.5
MCYRR-10 MCYR-10	MCYRR-10-S MCYR-10-S	10	9.992	30	14	15	14.82	1
MCYRR-12 MCYR-12	MCYRR-12-S MCYR-12-S	12	11.992	32	14	15	14.82	1
MCYRR-15 MCYR-15	MCYRR-15-S MCYR-15-S	15	14.992	35	18	19	18.79	1
MCYRR-17 MCYR-17	MCYRR-17-S MCYR-17-S	17	16.992	40	20	21	20.79	1.5
MCYRR-20 MCYR-20	MCYRR-20-S MCYR-20-S	20	19.990	47	24	25	24.79	1.5
MCYRR-25 MCYR-25	MCYRR-25-S MCYR-25-S	25	24.990	52	24	25	24.79	1.5
MCYRR-30 MCYR-30	MCYRR-30-S MCYR-30-S	30	29.990	62	28	29	28.79	1.5
MCYRR-35 MCYR-35	MCYRR-35-S MCYR-35-S	35	34.988	72	28	29	28.79	2
MCYRR-40 MCYR-40	MCYRR-40-S MCYR-40-S	40	39.988	80	30	32	31.75	2
MCYRR-45 MCYR-45	MCYRR-45-S MCYR-45-S	45	44.988	85	30	32	31.75	2
MCYRR-50 MCYR-50	MCYRR-50-S MCYR-50-S	50	49.988	90	30	32	31.75	2

(1) Standard bearing has a crowned roller outside diameter. For straight cylindrical outside diameter, add suffix "X". (Example - MCYRR-15-X or MCYR-15-SX)
 (2) Tolerance limits for Roller Diameter are shown below.

Cylindrical Roller Dia. "RD"

RD (NOM.)		TOLERANCE	
OVER	INCL.	MAX.	MIN.
mm	mm	mm	mm
6	18	0	-0.008
18	30	0	-0.009
30	50	0	-0.011
50	80	0	-0.013
80	120	0	-0.015

Crowned Roller Dia. "RD"

RD (NOM.)		TOLERANCE	
OVER	INCL.	MAX.	MIN.
mm	mm	mm	mm
6	120	0	-0.050



MCYRR-S

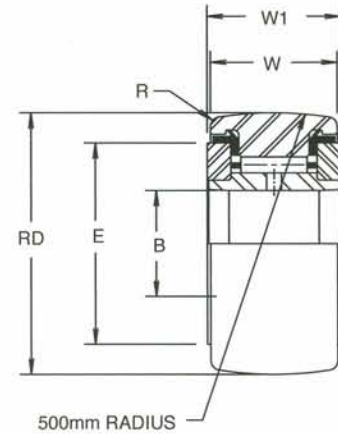

UNSEALED BEARING NUMBER (1)	SEALED BEARING NUMBER (1)	MOUNTING DIMENSIONS					LIMITING SPEED		LOAD RATINGS				MASS kg
		SHAFT DIAMETER (3)				CLAMPING DIA. E	GREASE (4)	OIL (4)	ISO/ABMA BASIC LOAD RATINGS NEWTONS		TRACK ROLLER LOAD RATINGS NEWTONS		
		LOOSE FIT FOR LIGHT LOADS g6		LIGHT TRANSITION FIT FOR MEDIUM LOADS h6					DYNAMIC	STATIC	DYNAMIC	STATIC	
		MAX.	MIN.	MAX.	MIN.								
		mm	mm	mm	mm	mm	rpm	rpm					
MCYRR-5 MCYR-5	MCYRR-5-S MCYR-5-S	4.996	4.988	5	4.992	11	19500 13000	25000 17000	4120 6960	4120 8340	3430 5790	3380 6900	0.011 0.014
MCYRR-6 MCYR-6	MCYRR-6-S MCYR-6-S	5.996	5.988	6	5.992	13	15500 10500	20000 13500	4510 8040	5000 10490	3730 6670	4090 8760	0.018 0.021
MCYRR-8 MCYR-8	MCYRR-8-S MCYR-8-S	7.995	7.986	8	7.991	16	12500 8400	16000 11000	6860 11470	7750 15200	5690 9610	6450 12600	0.040 0.043
MCYRR-10 MCYR-10	MCYRR-10-S MCYR-10-S	9.995	9.986	10	9.991	19	9600 6400	12500 8300	8240 13340	9710 18240	6860 11080	8050 15300	0.060 0.062
MCYRR-12 MCYR-12	MCYRR-12-S MCYR-12-S	11.994	11.983	12	11.989	21	8100 5400	10500 7000	8730 14420	10890 20890	7260 12060	9120 17400	0.067 0.069
MCYRR-15 MCYR-15	MCYRR-15-S MCYR-15-S	14.994	14.983	15	14.989	24	6300 4200	8200 5400	13040 20300	19030 34130	10890 16970	15900 28500	0.102 0.105
MCYRR-17 MCYR-17	MCYRR-17-S MCYR-17-S	16.994	16.983	17	16.989	27	4900 3300	6400 4300	15990 23240	23730 38540	13340 19420	19700 32200	0.150 0.153
MCYRR-20 MCYR-20	MCYRR-20-S MCYR-20-S	19.993	19.980	20	19.987	30	3900 2600	5000 3400	21280 30790	35700 57670	17750 25690	29800 48000	0.252 0.255
MCYRR-25 MCYR-25	MCYRR-25-S MCYR-25-S	24.993	24.980	25	24.987	36	3300 2200	4300 2900	22950 34130	41780 70410	19120 28440	34900 58700	0.278 0.284
MCYRR-30 MCYR-30	MCYRR-30-S MCYR-30-S	29.993	29.980	30	29.987	44	2500 1700	3200 2200	34030 49720	65120 107290	28340 41480	54300 89000	0.465 0.476
MCYRR-35 MCYR-35	MCYRR-35-S MCYR-35-S	34.991	34.975	35	34.984	52	2200 1500	2800 1900	38930 56880	72960 120230	32460 47370	60900 100000	0.636 0.649
MCYRR-40 MCYR-40	MCYRR-40-S MCYR-40-S	39.991	39.975	40	39.984	58	1900 1300	2400 1700	49720 70020	94440 147990	41480 58350	78700 123000	0.825 0.845
MCYRR-45 MCYR-45	MCYRR-45-S MCYR-45-S	44.991	44.975	45	44.984	63	1800 1200	2300 1500	51190 73750	101010 163190	42760 61490	84100 136000	0.901 0.924
MCYRR-50 MCYR-50	MCYRR-50-S MCYR-50-S	44.991	49.975	50	49.984	68	1600 1100	2000 1400	54720 77180	113570 178390	45600 64330	94800 148000	0.960 0.984

- (3) For a tight fit and heavy loads, use ISO tolerance j6.
- (4) Since load, lubrication method, temperature and other factors affect the maximum operating speed, it is impossible to determine precise limiting speed. The listed limiting speeds are based on lightly loaded bearings having adequate lubrication and are listed only as a design guide. If grease lubricated, frequent relubrications is required. Actual bearing testing in the specific application should be conducted if the anticipated operating speed approaches the listed limiting speed.
- (5) Dynamic load should not exceed 50% of Dynamic Rating as a track roller.

MCFD SERIES

STUD TYPE

Series MCFD — Shielded, full complement of cylindrical rollers

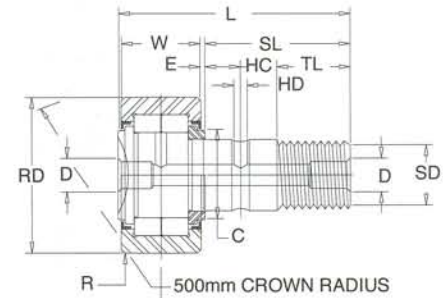

MCFD

BEARING NO.	ROLLER DIA. RD (1)	ROLLER WIDTH W	STUD DIA. SD	STUD L'GTH. SL	OVERALL LENGTH L	ENDPLATE EXTENSION E	THREAD	THREAD LENGTH TL	OIL HOLE		REAMED HOLE D
	NOM.	+0.00 -0.12	NOM.	NOM.	NOM.	NOM.			HC NOM.	HD NOM.	
	mm	mm	mm	mm	mm	mm			mm	mm	
MCFD-35	35	18	16	32.5	52	0.8	M16x1.5	17	8	3	6
MCFD-40	40	20	18	36.5	58	0.8	M18x1.5	19	8	3	6
MCFD-47	47	24	20	40.5	66	0.8	M20x1.5	21	9	4	8
MCFD-52	52	24	20	40.5	66	0.8	M20x1.5	21	9	4	8
MCFD-62	62	29	24	49.5	80	0.8	M24x1.5	25	11	4	8
MCFD-72	72	29	24	49.5	80	0.8	M24x1.5	25	11	4	8
MCFD-80	80	35	30	63.0	100	1.0	M30x1.5	32	15	4	8
MCFD-90	90	35	30	63.0	100	1.0	M30x1.5	32	15	4	8

BEARING NO.	CORNER RADIUS R MIN.	ENDPLATE DIA. C	CLAMPING TORQUE (3) MAX.	LIMITING SPEED (2)		HOUSING BORE DIA.		LOAD RATING (NEWTONS)				BRG. MASS (APPROX.) Kg
				GREASE	OIL	mm		ISO LOAD RATING		LOAD RATING AS TRACK ROLLER		
						rpm	rpm	MIN.	MAX.	DYNAMIC	STATIC	
MCFD-35	0.6	21	57	6500	8500	16.000	16.018	23000	27000	16000	18000	.165
MCFD-40	1.0	23	85	5500	7200	18.000	18.018	25000	31000	18000	22000	.242
MCFD-47	1.0	27	118	4200	5500	20.000	20.021	38000	48000	27000	32000	.380
MCFD-52	1.0	21	118	3400	4400	20.000	20.021	42000	57000	30000	35000	.450
MCFD-62	1.0	38	216	2600	3400	24.000	24.021	58000	76000	41000	48000	.795
MCFD-72	1.1	44	216	2100	2700	24.000	24.021	64000	89000	46000	57000	1.010
MCFD-80	1.1	47	441	1800	2300	30.000	30.021	94000	129000	67000	91000	1.540
MCFD-90	1.1	47	441	1800	2300	30.000	30.021	94000	129000	67000	101000	1.960

- (1) Standard bearing has a crowned roller outside diameter. For straight cylindrical outside diameter, add suffix "X". (Example - MCFD-35-X)
- (2) Since load, lubrication method, temperature and other factors affect the maximum operating speed, it is impossible to determine precise limiting speed. The listed limiting speeds are based on lightly loaded bearings having adequate lubrication and are listed only as a design guide. If grease lubricated, frequent relubrication is required. Actual bearing testing in the specific application should be conducted if the anticipated operating speed approaches the listed limiting speed.
- (3) Clamping torque is based on dry threads. If threads are lubricated, use half of value shown.

Tolerance limits for Cylindrical Roller Dia. "RD"

RD (NOM.)		TOLERANCE	
OVER	INCL.	MAX.	MIN.
mm	mm	mm	mm
30	50	0	-0.011
50	80	0	-0.013
80	120	0	-0.015

Tolerance limits for Crowned Roller Dia. "RD"

RD (NOM.)		TOLERANCE	
OVER	INCL.	MAX.	MIN.
mm	mm	mm	mm
30	120	0	-0.050

Tolerance limits for Stud Dia. "SD"

SD (NOM.)		TOLERANCE	
OVER	INCL.	MAX.	MIN.
mm	mm	mm	mm
10	18	0	-0.018
18	30	0	-0.021

YOKE TYPE

Series MCYRD — Shielded, full complement of cylindrical rollers

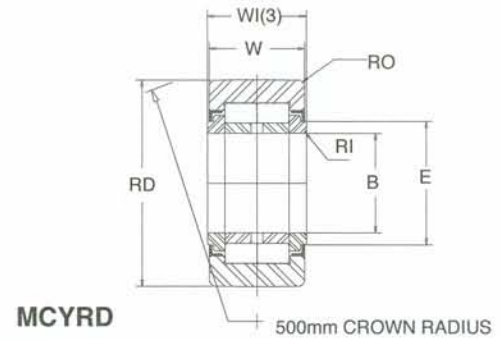

BEARING NO.	BORE DIA. B		ROLLER DIA. RD (1)	W. +0.00 -0.12	BEARING WIDTH WI		CORNER HEIGHT MIN.		WASHER DIA. E	LOAD RATING (NEWTONS)				LIMITING SPEED (2)	BRG. MASS (APPROX.)
	MAX.	MIN.			MAX.	MIN.	Ro	Ri		ISO LOAD RATING		LOAD RATING AS TRACK ROLLER			
	mm	mm			mm	mm	mm	mm		DYNAMIC	STATIC	DYNAMIC	STATIC		
MCYRD-15	15	14.992	35	18	19	18.79	0.6	0.3	20	23000	27000	16000	18000	6500	0.099
MCYRD-17	17	16.992	40	20	21	20.79	1.0	0.3	22	25000	31000	18000	22000	5500	0.147
MCYRD-20	20	19.990	47	24	25	24.79	1.0	0.3	27	38000	48000	27000	32000	4200	0.245
MCYRD-25	25	24.990	52	24	25	24.79	1.0	0.3	31	42000	57000	30000	35000	3400	0.281
MCYRD-30	30	29.990	62	28	29	28.79	1.0	0.3	38	58000	76000	41000	47000	2600	0.465
MCYRD-35	35	34.988	72	28	29	28.79	1.1	0.6	44	64000	89000	46000	57000	2100	0.630
MCYRD-40	40	39.988	80	30	32	31.75	1.1	0.6	51	89000	130000	64000	71000	1600	0.816
MCYRD-45	45	44.988	85	30	32	31.75	1.1	0.6	55	94000	143000	67000	72000	1400	0.883
MCYRD-50	50	49.988	90	30	32	31.75	1.1	0.6	60	99000	156000	71000	77000	1300	0.950

- (1) Standard bearing has a crowned roller outside diameter. For straight cylindrical outside diameter, add suffix "X". (Example - MCYRD-15-X)
- (2) Since load, lubrication method, temperature and other factors affect the maximum operating speed, it is impossible to determine precise limiting speed. The listed limiting speeds are based on lightly loaded bearings having adequate lubrication and are listed only as a design guide. If grease lubricated, frequent relubrication is required. Actual bearing testing in the specific application should be conducted if the anticipated operating speed approaches the listed limiting speed.
- (3) Positive clamping across endplates required to insure proper end play after mounting.

Tolerance limits for roller diameter
Cylindrical Roller Dia. "RD"

RD (NOM.)		TOLERANCE	
OVER	INCL.	MAX.	MIN.
mm	mm	mm	mm
6	18	0	-0.008
18	30	0	-0.009
30	50	0	-0.011
50	80	0	-0.013
80	120	0	-0.015

Crowned Roller Dia. "RD"

RD (NOM.)		TOLERANCE	
OVER	INCL.	MAX.	MIN.
mm	mm	mm	mm
6	120	0	-0.050

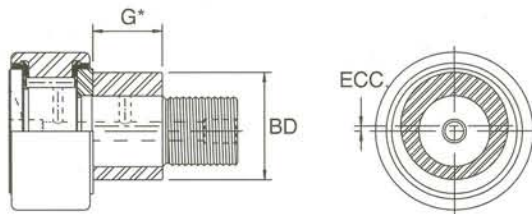

(For other dimensions refer to tabulated chart)

BASIC BEARING NUMBER	G*	BD		ECC. ECCENTRICITY	RECOMMENDED HOUSING BORE DIA.
	+0.05 -0.15	mm			+0.025 -0.000
	mm	MIN.	MAX.		mm
16	7	8.964	9.000	0.5	9.050
19	9	10.957	11.000	0.5	11.050
22	10	12.957	13.000	0.5	13.050
22A	10	12.957	13.000	0.5	13.050
26	10	12.957	13.000	0.5	13.050
26A	10	12.957	13.000	0.5	13.050
30	11	14.957	15.000	0.5	15.050
32	11	14.957	15.000	0.5	15.050
35	14	19.948	20.000	1.0	20.050
40	16	21.948	22.000	1.0	22.050
40A	16	21.948	22.000	1.0	22.050
47	18	23.948	24.000	1.0	24.050
47A	18	23.948	24.000	1.0	24.050
52	18	23.948	24.000	1.0	24.050
52A	18	23.948	24.000	1.0	24.050
62	22	27.948	28.000	1.0	28.050
62A	22	27.948	28.000	1.0	28.050
72	22	27.948	28.000	1.0	28.050
72A	22	27.948	28.000	1.0	28.050
80	29	34.938	35.000	1.5	35.050
85	29	34.938	35.000	1.5	35.050
90	29	34.938	35.000	1.5	35.050

*For positive clamping, housing thickness should be 0.3 mm greater than G dimension.

STUD TYPE METRIC CAM FOLLOWERS: Needle Roller Cage and Full Complement Types

McGILL		INA	SKF	NTN	IKO	THK	
CAGE	FULL COMPLEMENT	CAGE	FULL COMPLEMENT	CAGE	FULL COMPLEMENT	CAGE	FULL COMPLEMENT
MCFR-13	-	-	-	-	CF5	-	
MCFR-16	MCF-16	KR-16	KRV-16	-	CF6R	CF6VR	
MCFR-19	MCF-19	KR-19	KRV-19	-	CF8R	CF8VR	
MCFR-22	MCF-22	KR-22	KRV-22	-	-	-	
MCFR-22A	MCF-22A	-	-	-	CF10R	CF10VR	
MCFR-26	MCF-26	KR-26	KRV-26	-	-	-	
MCFR-26A	MCF-26A	-	-	-	CF10-1R	CF10-1VR	
MCFR-30	MCF-30	KR-30	KRV-30	-	CF12R	CF12VR	
MCFR-32	MCF-32	KR-32	KRV-32	-	CF12-1R	CF12-1VR	
MCFR-35	MCF-35	KR-35	KRV-35	-	CF16R	CF16VR	
MCFR-40	MCF-40	KR-40	KRV-40	-	-	-	
MCFR-40A	MCF-40A	-	-	-	CF18R	CF18VR	
MCFR-47	MCF-47	KR-47	KRV-47	-	-	-	
MCFR-47A	MCF-47A	-	-	-	CF20-1R	CF20-1VR	
MCFR-52	MCF-52	KR-52	KRV-52	-	-	-	
MCFR-52A	MCF-52A	-	-	-	CF20R	CF20VR	
MCFR-62	MCF-62	KR-62	KRV-62	-	-	-	
MCFR-62A	MCF-62A	-	-	-	CF24R	CF24VR	
MCFR-72	MCF-72	KR-72	KRV-72	-	-	-	
MCFR-72A	MCF-72A	-	-	-	CF24-1R	CF24-1VR	
MCFR-80	MCF-80	KR-80	KRV-80	-	CF30R	CF30VR	
MCFR-85	MCF-85	KR-85	-	-	CF30-1R	CF30-1VR	
MCFR-90	MCF-90	KR-90	KRV-90	-	CF30-2R	CF30-2VR	

HEAVY-DUTY Cylindrical Roller Type

McGILL	INA FAG NTN
MCFD-35	NUKR-35
MCFD-40	NUKR-40
MCFD-47	NUKR-47
MCFD-52	NUKR-52
MCFD-62	NUKR-62
MCFD-72	NUKR-72
MCFD-80	NUKR-80
MCFD-90	NUKR-90



YOKE TYPE METRIC CAM FOLLOWERS: Needle Roller Cage and Full Complement Types

McGILL		INA	SKF	NTN	IKO	THK	
CAGE	FULL COMPLEMENT	CAGE	FULL COMPLEMENT	CAGE	FULL COMPLEMENT	CAGE	FULL COMPLEMENT
MCYRR-5	MCYR-5	NATR-5	NATV-5	NART-5R	NART-5VR		
MCYRR-6	MCYR-6	NATR-6	NATV-6	NART-6R	NART-6VR		
MCYRR-8	MCYR-8	NATR-8	NATV-8	NART-8R	NART-8VR		
MCYRR-10	MCYR-10	NATR-10	NATV-10	NART-10R	NART-10VR		
MCYRR-12	MCYR-12	NATR-12	NATV-12	NART-12R	NART-12VR		
MCYRR-15	MCYR-15	NATR-15	NATV-15	NART-15R	NART-15VR		
MCYRR-17	MCYR-17	NATR-17	NATV-17	NART-17R	NART-17VR		
MCYRR-20	MCYR-20	NATR-20	NATV-20	NART-20R	NART-20VR		
MCYRR-25	MCYR-25	NATR-25	NATV-25	NART-25R	NART-25VR		
MCYRR-30	MCYR-30	NATR-30	NATV-30	NART-30R	NART-30VR		
MCYRR-35	MCYR-35	NATR-35	NATV-35	NART-35R	NART-35VR		
MCYRR-40	MCYR-40	NATR-40	NATV-40	NART-40R	NART-40VR		
MCYRR-45	MCYR-45	NATR-45	-	NART-45R	NART-45VR		
MCYRR-50	MCYR-50	NATR-50	NATV-50	NART-50R	NART-50VR		

HEAVY-DUTY Cylindrical Roller Type

McGILL	INA FAG	NTN
MCYRD-15	NUTR-15	NUTR-202
MCYRD-17	NUTR-17	NUTR-203
MCYRD-20	NUTR-20	NUTR-204
MCYRD-25	NUTR-25	NUTR-205
MCYRD-30	NUTR-30	NUTR-206
MCYRD-35	NUTR-35	NUTR-207
MCYRD-40	NUTR-40	NUTR-208
MCYRD-45	NUTR-45	NUTR-209
MCYRD-50	NUTR-50	NUTR-210



Coding for Other Cam Follower and Yoke Roller Types

OPTIONAL FEATURES	McGILL	INA	SKF	IKO	NTN	THK
Seals**	Add Suffix "S"	Add Suffix "PP"	Add Suffix "UU"	Add Suffix "UU"	Add Suffix "LL"	Add Suffix "UU"
Cylindrical OD	Add Suffix "X"	Add Suffix "X"	Remove Suffix "R"	Add Suffix "X"	Remove Suffix "R"	Remove Suffix "R"
Hexagonal Hole*	Add Suffix "B"	Add Suffix "SK"	Add Suffix "B"	Add Suffix "H"	Add Suffix "A"	Add Suffix "A"
Eccentric Collar*	Add Prefix "E"	Add Prefix "E"	Add Prefix "E"	-	-	-

*Not applicable for yoke roller types

**Not applicable for heavy-duty cylindrical roller type.



McGILL®

Metric CAMROL® Bearings

Cam Follower and Specialty Bearings.
McGill precision bearings, including the original CAMROL cam follower bearings, are available in a wide variety of standard and special "MTO" designs to suit the application.

SEALMASTER®

Browning

Morse

KOP-FLEX®

ROLLWAY®

McGILL

the power of
EPT™

www.emerson-ept.com

Emerson Power Transmission
United States — 1-800-626-2120
Canada — 1-800-268-4149

McGill Customer Service:
Telephone 219-465-2200 Fax 219-465-2290

APPLICATION CONSIDERATIONS

The proper selection and application of power transmission products and components, including the related area of product safety, is the responsibility of the customer. Operating and performance requirements and potential associated issues will vary appreciably depending upon the use and application of such products and components. The scope of the technical and application information included in this publication is necessarily limited. Unusual operating environments and conditions, lubrication requirements, loading supports, and other factors can materially affect the application and operating results of the products and components and the customer should carefully review its requirements. Any technical advice or review furnished by Emerson Power Transmission Corporation and its divisions with respect to the use of products and components is given in good faith and without charge, and Emerson assumes no obligation or liability for the advice given, or results obtained, all such advice and review being given and accepted at customer's risk.

For a copy of our Standard Terms and Conditions of Sale, Disclaimers of Warranty, Limitation of Liability and Remedy, please contact Emerson Power Transmission Customer Service at 1-800-626-2120. These terms and conditions of sale, disclaimers and limitations of liability apply to any person who may buy, acquire or use an Emerson Power Transmission Corporation product referred to herein, including any person who buys from a licensed distributor of these branded products.

Morse is a registered trademark of Borg-Warner Corporation used herein under license.

MGB-07
Form 9083 • 6/07 • Printed in U.S.A.

EMERSON
Industrial Automation

EMERSON. CONSIDER IT SOLVED.™