



SECTION 1 SPHERICAL BEARINGS – Self-Lubricating (Downlad Tables PDF)

SECTION 2 SPHERICAL BEARINGS – Metal-to-Metal (Downlad Tables PDF)

SECTION 3 LOADER SLOT BEARINGS (Downlad Tables PDF)

SECTION 4 ROD END BEARINGS – Self-Lubricating (Downlad Tables PDF)

SECTION 5 ROD END BEARINGS – Metal-to-Metal (Downlad Tables PDF)

SECTION 6 SLEEVE BEARINGS – Self-Lubricating (Downlad Tables PDF)

SECTION 7 ENGINEERING

Product Applications	52
Bearing Types and Details of Construction	53
Bearing Materials	58
Self-Lubricating Liner Systems	59
Grease and Dry Film Lubricants	66
Locking Devices, Keys and Keyways	68
Sealed Bearings	70
Bearing Installation and Retention	71
Staking Tool Sets – Ordering Information	77
Load Ratings and Misalignment Capabilities	78
Bearing Selection Factors	84
Specifications Compliance	86
Inch/Metric Conversion Table	87
Fahrenheit/Celsius Conversion Table	88

[NHBB Capabilities](#) 90



SECTION 7

ENGINEERING

Product Applications52
Bearing Types and Details of Construction53
Bearing Materials58
Self-Lubricating Liner systems59
Grease and Dry Film Lubricants66
Locking Devices, Keys and Keyways68
Sealed Bearings70
Bearing Installation and Retention71
Staking Tool Sets – Ordering Information77
Load Ratings and Misalignment Capabilities78
Bearing Selection Factors84
Specifications Compliance86
Inch/Metric Conversion Table87
Fahrenheit/Celsius Conversion Table88



Product Applications

NHBB manufactures many different styles of spherical, rod end, and sleeve bearings. NHBB products are used extensively in the aerospace industry in rotary wing aircraft, fixed wing aircraft, and jet engine applications.

1, **2** and **3** illustrate the various areas in which NHBB bearings continue to find wide acceptance.

1 Rotary wing aircraft applications for spherical, rod end, and sleeve bearings.

- (1) Main rotor pitch change links, damper bearings, and swashplate bearings;
- (2) tail rotor pitch change links and bearings;
- (3) landing gear actuator and support bearings;
- (4) engine mount bearings;
- (5) controls for main and tail rotor.

2 Fixed wing aircraft applications for spherical, rod end, track roller, and sleeve bearings.

- (1) Nose landing gear actuator, steering and support bearings;
- (2) main landing gear actuator and support bearings;
- (3) door and canopy actuator and support bearings;
- (4A) leading edge slat actuator and support bearings;
- (4B) trailing edge flap actuator and support bearings;
- (4C) spoiler actuator and support bearings;
- (4D) aileron actuator and support bearings;
- (5) horizontal stabilizer actuator and support bearings;
- (6) vertical stabilizer actuator and support bearings;
- (7) thrust reverser actuator bearings;
- (8) pylon and engine mount bearings.

3 Jet engine applications for spherical, rod end, track roller, sleeve bearings and composites.

- (1) Fan, variable geometry actuator bearings;
- (2) compressor, variable geometry actuator bearings;
- (3) variable nozzle, actuator bearings;
- (4) thrust reverser and blocker door actuator and support bearings;
- (5) engine mounts;
- (6) gearbox mounts;
- (7) oil tank mounts;
- (8) oil cooler mounts.

1

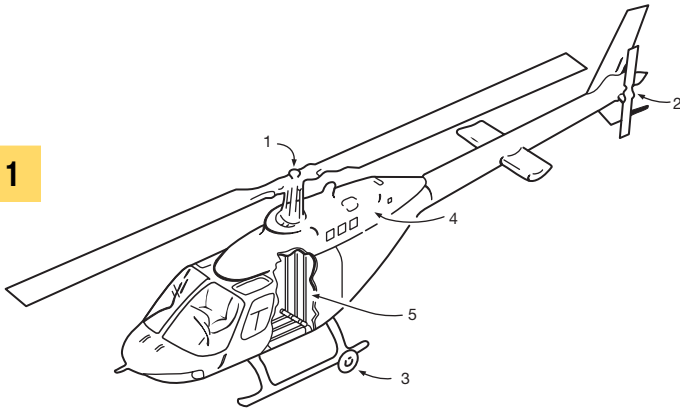

2

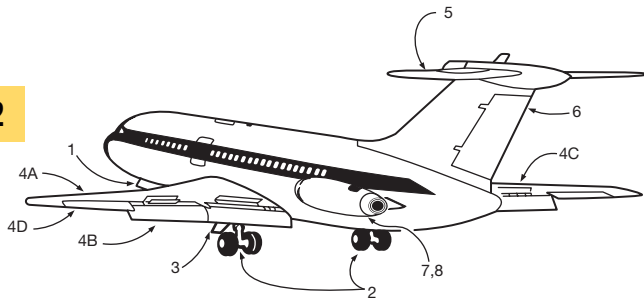

3

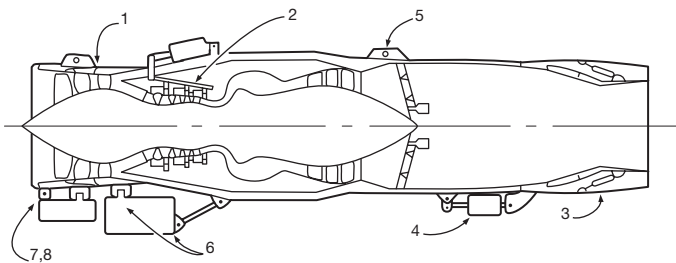



Bearing Types and Details of Construction

NHBB, Astro Division produces a variety of sliding surface bearings. The construction and material selection of each varies depending on factors such as load, temperature, hardness, and dimensional limitations. NHBB engineers are also pleased to discuss the design and manufacture of special bearing designs.

For a discussion of the available liner and lubrication systems, see pages 59-60 and 66-67, respectively.

SWAGED BEARINGS

The primary product of NHBB, Astro Division is the swaged spherical bearing. This bearing is manufactured by swaging a ductile race around a hardened ball. The race is machined and the assembly loosened (released) to obtain proper clearance or torque, or both, and then ground to finished size.

Swaged sphericals normally feature 80% to 100% contact between the race I.D. and the ball O.D. The large contact area between ball and race allows the all-metal bearing to take very high static loads and beryllium copper and TEFLON® lined bearings to take high static and dynamic loads.

4 Shows the assembly procedures for a swaged spherical bearing.

An alternative swaging method used when the bearing geometry precludes or renders impractical the double swaging method is shown in **5**. The pre-form design is used when the bearing outer race is not symmetrical about the spherical centerline due to a flange or a wide overhang on one side, or a combination of both. In such case, the problem side of the race is pre-formed by machining and grinding, and the opposite side only is swaged.

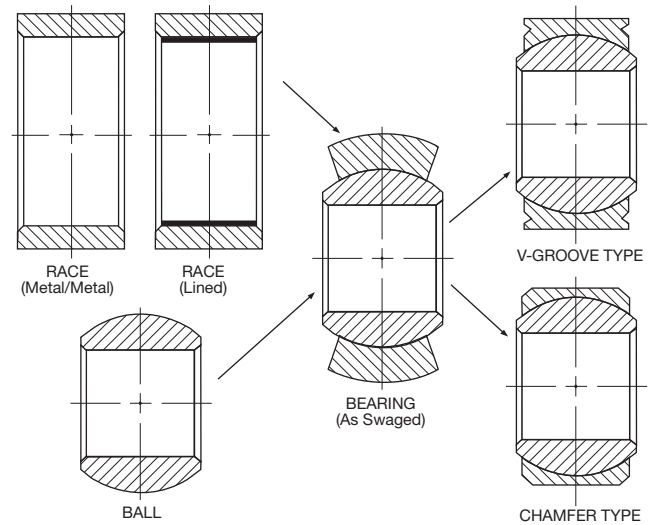

4

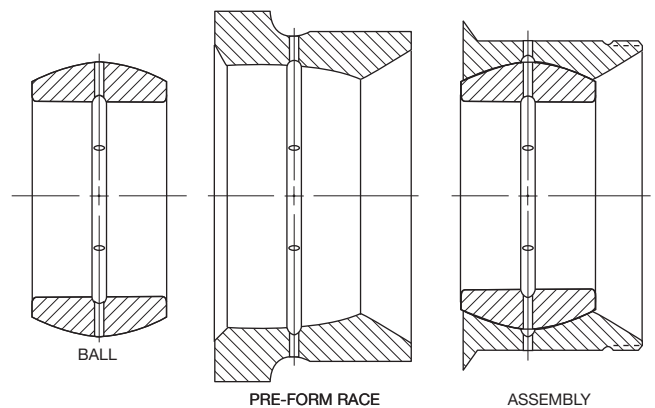

5

Bearing Types and Details of Construction

LOADER SLOT BEARINGS

A loader slot bearing, is a non-swaged bearing type (see **6**). The spherical race ID is fully machined, case hardened, and lapped. The race has entry slots machined 180° apart into one face of the race to facilitate assembly of the ball.

Attributes of this design are:

- Non-swageable race materials can be used.
- Race spherical ID's can be chemically or physically enhanced to improve wear resistance (ie: nitriding or plating).
- Ball replaceability; generally, the ball wears at a more rapid rate than the hardened race spherical ID. The loader slot design allows for the ball to be replaced without removing the bearing assembly from the housing. The net effect is reduced down time and maintenance cost due to on-wing repair.
- Race spherical ID can be lapped to a very close tolerance to provide excellent ball-to-race conformity.
- When required, the race can be designed with the sphere/slot entry intersection off-center. This design provides for a slight entry slot/ball interference (sometimes referred to as pop-in). This prevents the ball from falling out of the slot during shipping or handling.
- Entry slots should be oriented 90° with respect to the load. This bearing is generally recommended for applications with vibratory or static loads where there is small relative motion between the ball and race. This bearing is not recommended for applications where there is moderate to high relative motion between the ball and race under load. Under these conditions for long durations, these bearings exhibit high friction and excessive wear.

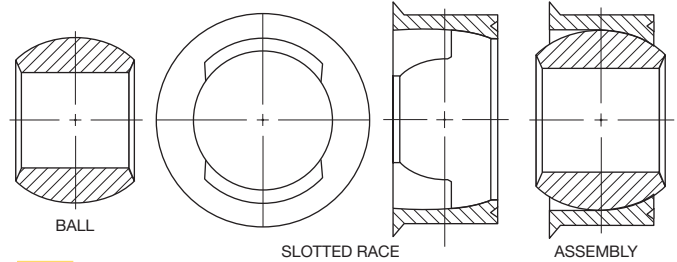

6

Loader Slot Bearing

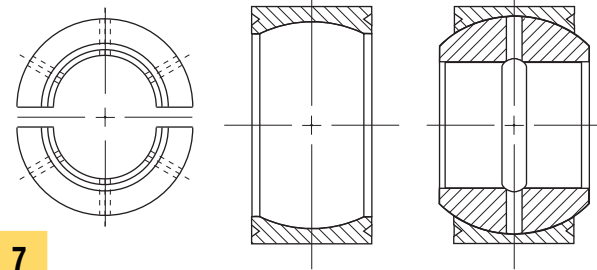

7

Two-Piece, Split Ball Spherical Bearing

SPLIT BALL SPHERICAL BEARINGS

Split ball spherical bearings (see **7**) are designed to offer similar advantages to grease lubricated load slot bearings. Unlike the load slot bearing, there is no loss of bearing area due to the entry slot. Split ball designs are intended for applications only where pin rotation will occur. There is no clamping on the ball faces.

The split ball is machined and ground in matched sets with a “zero” gap at the separation plane. The ball is typically a copper alloy. Like the load slot bearing, the race is fully machined, wear surface hardened, then finished with a lap operation. Because the race is the harder member, wear is intended to occur on the ball. The split ball feature allows the ball to be replaced “on the aircraft” in certain applications.



FRACTURED RACE BEARINGS

Fractured race bearings (see **8**) are an alternative to loader slot bearings. In this design the race is ground all over (including the race I.D.), notched, and transversely fractured in half.

This bearing has full ball-to-race contact, which reduces stress and results in reduced wear, particularly in high vibration applications. This type of bearing must utilize a very hard race to facilitate the fracturing process.

The advantage of fractured race bearings is that no bearing area is sacrificed. TEFLON® liners are not usually used in these bearings.

SPLIT RACE BEARINGS

Split race bearings (see **9**) have a race that is circumferentially or transversely split. The resulting two half races are placed around the ball and retained by a housing.

Split race designs are used principally on larger bearings when installation in the application is difficult. These bearings can be made of any material and can incorporate a TEFLON® liner.

SNAP-ASSEMBLED BEARINGS

Snap-Assembled bearings, sometimes referred to as “snap-in”, are generally designed with a relatively large diameter, thin cross section, and narrow ball geometries (see **10**). NHBB uses a race width to ball diameter ratio of .20 as a design consideration for this bearing configuration. Snap-assembly is accomplished by deflecting the race, ball, or both within their elastic limits to allow entry of the ball into the race. This type of design is generally used only when all other methods are impractical or impossible due to problem geometry or processing restraints.

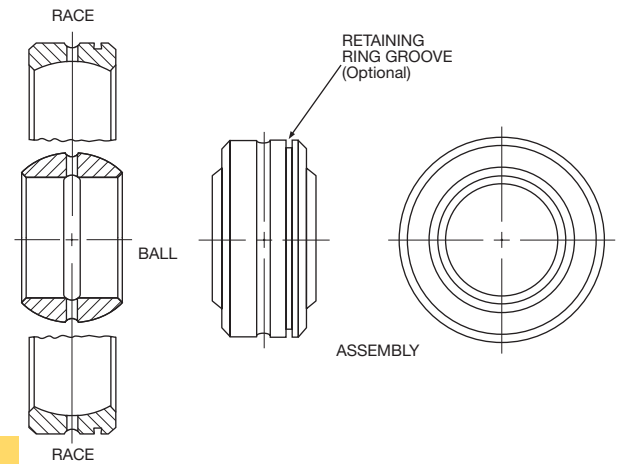

8

Fractured Race Bearing

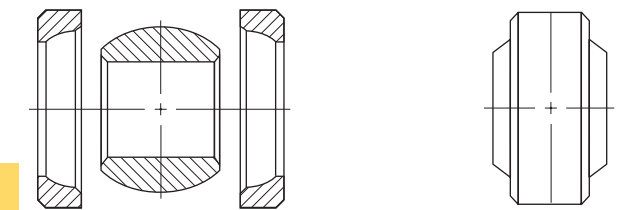

9

Split Race Bearing

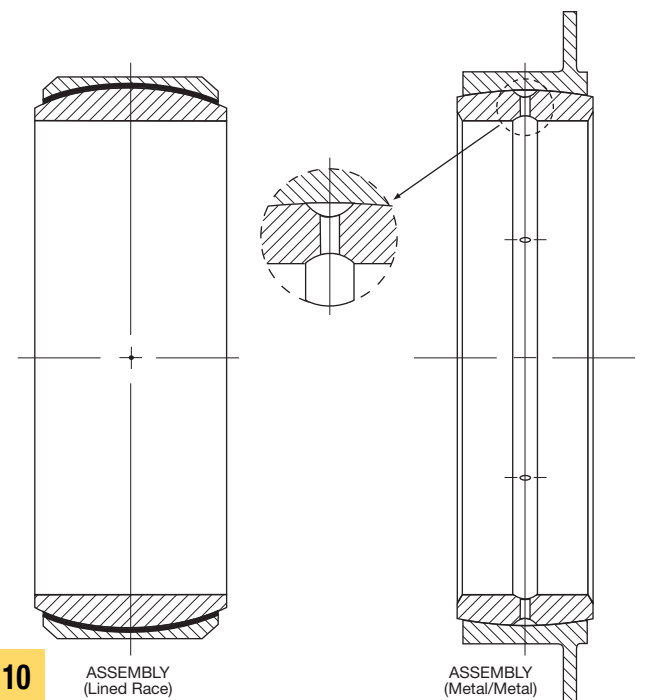

10

Snap-Assembled Bearings

Bearing Types and Details of Construction

NHBB manufacturers two- and three-piece rod ends. Two-piece rod ends consist of a rod end body and a ball. The three-piece rod end consists of a two-piece spherical bearing cartridge pressed and staked into a machined rod end body.

TWO-PIECE COINED ROD END

The coined two-piece rod end (see **11**) is used when maximum strength in a given envelope is required. The coined two-piece rod end has better ball-to-race conformity than a “mohawk rod end”, particularly in the area just above the shank. TEFLON® liner installation is not possible for this type of rod end.

TWO-PIECE MOHAWK ROD END

The Mohawk two-piece rod end (see **12**) is used for lightly loaded applications. However, head strength is sacrificed. TEFLON® liners are often used in this type of construction.

THREE-PIECE ROD END

The three-piece rod end (see **13** & **14**) is the standard and preferred construction at NHBB. It offers the best formed ball-to-race conformity and moderate strength. During manufacture, a swaged spherical bearing cartridge is installed in a rod end body and usually retained by staking. The most popular means of retention utilizes the V-groove (see **13**). The V-groove is machined into the bearing cartridge race face. The lip formed by this groove is flared over a chamfer in the housing. This method provides moderate thrust capacity and allows a worn bearing to be removed without damaging the housing. Three-piece rod ends may be TEFLON® lined.

A three-piece housing staked rod end configuration (see **14**) is generally used only when other factors such as non-ductile race material, insufficient race face area to facilitate a V-groove, or economy of production are factors.

LOADER SLOT AND SPLIT BALL ROD ENDS

Loader slot rod ends and split ball rod ends provide alternative two-piece precision ground ball and body construction with the same design benefits of the comparable spherical design. Maximum body strength and bearing projected area is offered by the split ball design because of the omission of the loader slot.

11

*Two-Piece,
Swage-Coined Rod End*

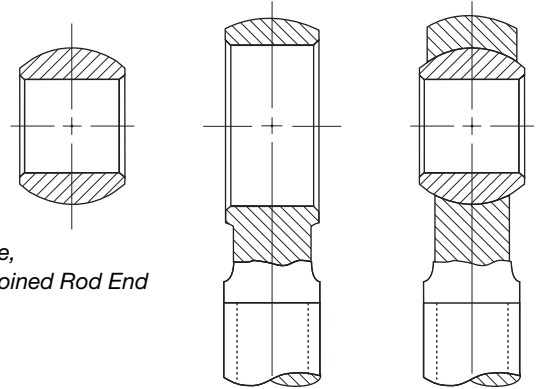

12

*Two-Piece,
Mohawk Rod End*

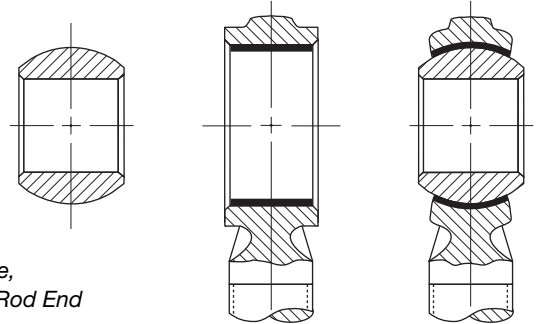

13

*Three-Piece,
V-Groove Staked Rod End*

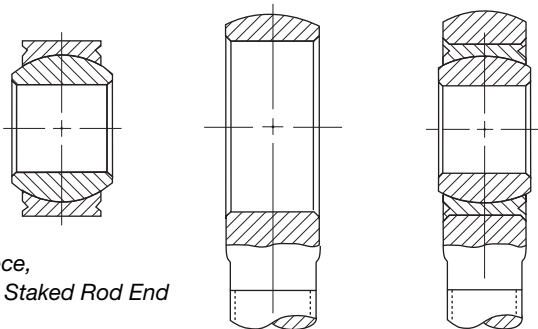

14

*Three-Piece,
Housing Staked Rod End*

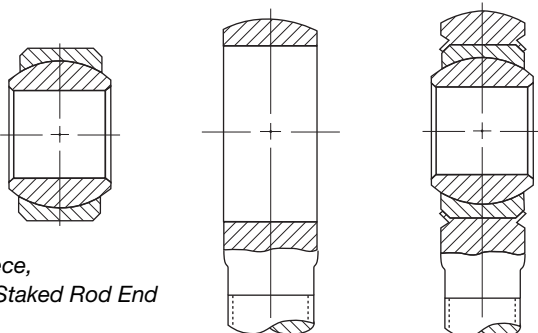



TRACK ROLLERS

NHBB manufactures track rollers (see **15** and **16**) as an alternative to needle roller bearings. The TEFLON® composite track roller can be designed to existing needle roller envelope dimensions. The track roller is made up of an outer member (roller) which slides over an inner member (bushing or stud) and these two members sandwich a low friction, low wearing TEFLON® composite material. The inner and outer members are retained in the axial direction by thrust washers that are either press fit, staked or welded onto the inner member to support axial loading.

Design features of NHBB's track rollers are high load carrying capability, resistance to many corrosive chemicals and environmental contaminants, and the ability to absorb heavy vibratory loads. Sliding surface track rollers offer improved bearing performance over needle rollers with respect to these design features.

While this product may be utilized in many rolling applications, it is not recommended for high rotational speeds or where low needle roller type frictional characteristics are required. For additional information, please contact NHBB Applications Engineering Department.

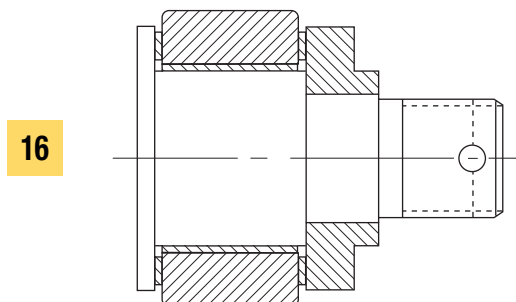
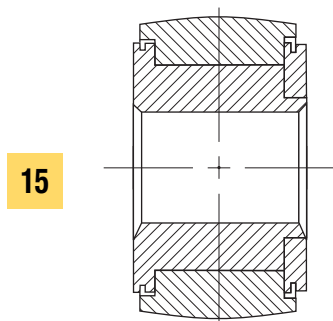

SLEEVE BEARINGS (SELF-LUBRICATING) MILITARY SERIES

17 Shows the NHBB AD series which are approved for procurement to M81934/1 P/N series.

18 Shows the NHBB ADLF series which are approved for procurement to M81934/2 P/N series.

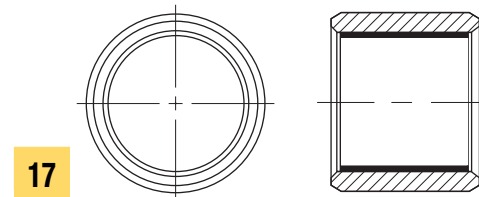

Plain, TEFLON® Lined

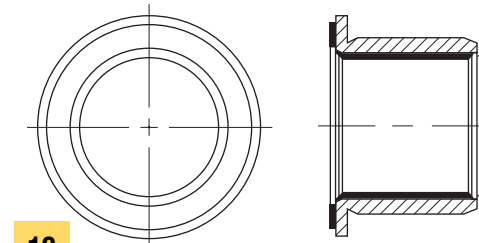

Flanged, TEFLON® Lined

Bearing Materials

BALL, RACE, AND ROD END BODY MATERIALS

In addition to the more common metals, NHBB's engineers and machinists work regularly with exotic materials. A partial list of commonly used ball, race, rod end body, and sleeve materials

is given in table 2. For materials not listed, please contact NHBB for available information.

TABLE 2: Common Bearing Alloys And Applications

Application	Corrosion Resistant Steel	Nickel Based	Cobalt Based	Titanium Based	Copper Based	Aluminum Based	Low Alloy Steels
BALL	303 440C PH13-8Mo 15-5PH 17-4PH A-286 BG42® Greek Ascology	Inconel® 718 Inconel® X-750 Rene 41® Waspaloy	Stellite®3 Stellite®6 Stellite®6B L-605 MP35N®	6Al 4V	Al Bronze Al-Ni Bronze Beryllium Copper	2024 6061 7075	4140 4340 52100 M-2 M-42 M-50 Maraging 250 Maraging 300 D-2
RACE	303, 304 410, 416, 422 431, 440C PH13-8Mo 15-5PH 17-4PH A-286 AM-355 Greek Ascology Nitronic® 60 BG42®	Inconel® 718 Inconel® X-750 Monel® 400 Monel® K500 Rene 41® Waspaloy	L-605	6Al 4V 3Al 2.5V	Al Bronze Beryllium Copper	2024 6061 7075	4130 4140 4340 52100 Maraging 300
ROD END/ LINK BODY	303, 316, 321 410, 416 PH13-8Mo 15-5PH 17-4PH A-286 AM-355	Inconel® 718 Inconel® X-750 Rene 41® Waspaloy	MP159® L-605	6Al 4V		2024 7075	1018 4130 4340 Maraging 250 8620
SLEEVE BEARINGS	321 410, 416 430, 440C PH13-8Mo 15-5PH 17-4PH BG42®	Inconel® 718 Inconel® 625 Rene 41® Waspaloy	L-605	6Al 4V	Al Bronze Al-Ni Bronze Beryllium Copper	2024 6061 7075	4130 4140 4340 9310

MP35N® and MP159® are registered trademarks of Standard Press Steel.
 INCONEL® is a registered trademark of Inco Alloys International, Inc. and The International Nickel Company, Inc.
 MONEL® is a registered trademark of Inco Alloys International, Inc.
 NITRONIC® is a registered trademark of Armco Inc.
 STELLITE® is a registered trademark of DELORO STELLITE COMPANY, INC.
 BG42® is a registered trademark of Latrobe Steel Company.



Self-Lubricating Liner Systems

Self-lubricating plain bearings incorporate a liner that includes polytetrafluorethylene (TEFLON®) on the bearing surface. The selection of a bearing liner system is based on factors of load, temperature, speed of oscillation, and the directional nature of the load.

NHBB uses three basic constructions for TEFLON® liner systems: laminates, woven materials, and metallic-backed composites (see 19, 20, and 21). Each TEFLON® liner system (except the DU® which is mechanically retained) is bonded to

the race surface and during use, TEFLON® transfers to the mating ball surface, forming a lubricating film that is continually replaced throughout the life of the liner material.

TEFLON® liner systems can also be applied to customer-supplied parts. Flat surfaces, cylindrical O.D.'s, cylindrical I.D.'s, spherical surfaces, and special configurations are routinely lined by NHBB's custom lining department by means of standard hard tooling or autoclave bonding.

LINER CONSTRUCTION LAMINATES

Laminates consist of an open weave backing fabric such as nylon, a porous TEFLON® bearing sheet, and a thermosetting phenolic adhesive bonding agent. The porous TEFLON® fabric is compressed into the backing fabric and impregnated with adhesive. Laminate construction is shown in 19.

WOVEN MATERIALS

Woven materials consist of TEFLON® threads interwoven with high strength fillers such as nylon, Polyester or fiberglass threads. The majority of the TEFLON® threads are on the bearing surface while the high-strength filler material supports the TEFLON® and acts as a bonding surface. As with laminates, the adhesive agent is a thermosetting phenolic. Woven material construction is shown in 20.

METALLIC-BACKED COMPOSITES

Metallic-backed composites consist of a steel backing, a porous bronze innerstructure, and a TEFLON® and lead overlay. In addition to using bonding techniques, this liner type can also be mechanically retained. Metallic-backed composite construction is shown in 21.

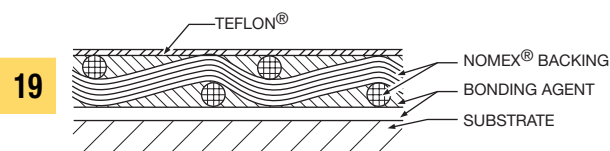

Laminate Construction

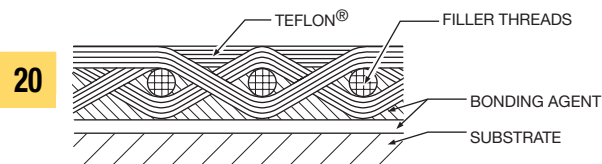

Woven Construction

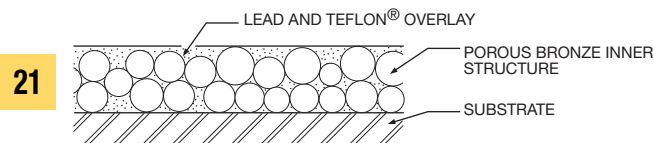

Metallic-Backed Composite Construction

TEFLON® is a Du Pont registered trademark

NOMEX® is a Du Pont registered trademark

DU® is a registered trademark of The Glacier Metal Company Limited

Self-Lubricating Liner Systems

TABLE 3: Self-Lubricating TEFLON® Liner Systems

Liner Type	AD/AD (L) or AK	K	D	DD
Liner Model	L-1291/L-1420	X-1820	L-1276	X-1470
Construction	TEFLON®/Nylon Laminate	TEFLON®/Nylon Weave	TEFLON®/Polyester Weave	TEFLON®/Polyester Weave
Thickness	.010-.012	.013-.015	.013-.015	.016-.018
Temperature	-65° to 400°F	-65° to 400°F	-65° to 250°F	-65° to 250°F
Static Limit Load	75000 psi	75000 psi	75000 psi	75000 psi
Typical Performance	37500 psi At ±25° and 10 cpm, .0045 wear max. at 25000 cycles	37500 psi at ±25° and 10 cpm, .0045 wear max. at 25000 cycles	Contact NHBB Engr. Dept.	Contact NHBB Engr. Dept.
Dynamic Capabilities	Light to heavy, uni-directional or alternating loads. Low speed, intermittent to continuous misalignment, intermittent to continuous oscillation	Light to heavy, uni-directional or alternating loads. Low speed, intermittent to continuous misalignment, intermittent to continuous oscillation	Light to medium, alternating or reversing loads. Medium to High speed, intermittent to continuous misalignment, intermittent to continuous oscillation	Light to medium, alternating or reversing loads. Medium to High speed, intermittent to continuous misalignment, intermittent to continuous oscillation
Typical Uses	Fixed wing aircraft, rotary wing aircraft and jet engines. Control, support and actuation bearings	Fixed wing aircraft, rotary wing aircraft and jet engines. Control, support and actuation bearings	Rotary wing aircraft and landing gear	Rotary wing aircraft and landing gear
Comments	Intermittent use to 500°F	Intermittent use to 500°F	Good stick/slip properties. Good for vibratory conditions	Good stick/slip properties. Good for vibratory conditions. Extended life over D liners due to additional thickness
Liner Type	HS	AT	HT	DU®
Liner Model	L-1340	X-1118	L-1390/L-1550	
Construction	TEFLON®/Polyester Weave	TEFLON®/Fiberglass Weave	TEFLON®/Fiberglass Weave	TEFLON®/Lead Bronze Composite
Thickness	.013-.015	.010-.012	.012-.014	.028-.030
Temperature	-65° to 250°F	-65° to 250°F	-65° to 625°F	-65° to 550°F
Static Limit Load	75000 psi	75000 psi	75000 psi	58000 psi
Typical Performance	(Contact NHBB)	25000 psi at ±25° and 10 cpm, .006 wear max. at 5000 cycles	12500 psi at ±25° and 10 cpm, .0045 wear max. at 25000 cycles	5000 psi at ±25° and 10 cpm, .0030 wear max. at 25000 cycles
Dynamic Capabilities	Light to medium, unidirectional loads. High speed, intermittent to continuous misalignment, intermittent to continuous oscillation	Light, uni-directional loads. Low speed, intermittent to continuous misalignment, intermittent to continuous oscillation	Light to medium, uni-directional or alternating loads. Low speed, intermittent to continuous misalignment, intermittent to continuous oscillation	Light, uni-directional or alternating loads. Low to high speed, intermittent to continuous misalignment, intermittent to continuous oscillation
Typical Uses	Rotary wing aircraft	Landing gear support and actuation bearings	Jet engine bearings and bushings	Rotary and fixed wing aircraft bearings and hinge bushings
Comments	DH (L-1480) liner offers same operating conditions but with a liner thickness of .018	Good stick/slip properties	Recommended for long term high temperature use, 450° to 625°F	

TEFLON® is a Du Pont registered trademark

DU® is a registered trademark of The Glacier Metal Company Limited



AD, AK AND K LINER SYSTEMS (DURALINERS)

NHBB's, AD, AK and K liner systems consist of TEFLON®, Nomex® and a thermosetting phenolic resin. The AD, AK and K liners are suitable for many fixed wing aircraft applications, such as actuators, hinges, and control bearings, where oscillation angles vary considerably but at slow oscillation speeds.

The AD, AK and K liners are qualified to AS81820 and AS81934. To qualify to AS81820, a lined bearing will be tested at room temperature for 25,000 cycles of ± 25 degrees at 10 cpm and at 37500 psi. Maximum allowable wear is 0.0045. When tested at elevated temperature requirement, the allowable wear is 0.006. When tested at -65°F , the load is reduced to 75% of the room temperature requirement, and the allowable wear is 0.008. AS81820 also has a test requirement for bearings to be immersed in various fluids for 24 hours at 160°F , removed from the fluid, and dynamically tested at 75% of the room temperature load requirement. NHBB's AD, AK and K liners consistently exhibit less wear than specifications allow. See 22 for typical liner performance at ambient temperature.

The AD, AK and K liners are capable of operating for long durations when exposed to 350°F and short durations up to 500°F .

Tests reveal that the AD liner meets most vacuum outgassing requirements of space applications.

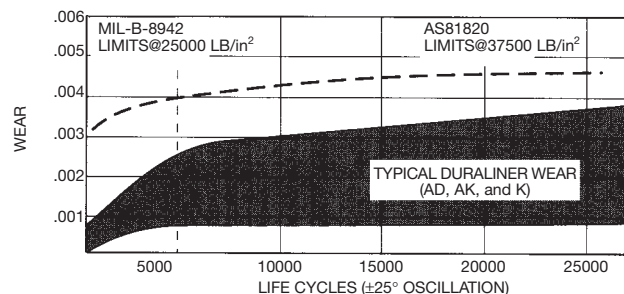

22 Typical Performance of AS81820 Liner Systems (Life Cycles $\pm 25^{\circ}$ Oscillation)

D AND DD LINER SYSTEMS

NHBB's D and DD liner systems consist of a TEFLON® and Dacron weave coated with a thermosetting resin. The D and DD liners differ in the thickness of the liner. The DD liner has a liner thickness of .017 (Ref) and the D liner has a thickness of .014 (Ref). The additional liner thickness offers additional bearing liner life.

The D and DD liners were developed to accommodate alternating and reversing loads typically found in rotary wing applications where there are relatively low loading (approximately 2,000 psi) and the speed of oscillation is relatively high (approximately 300 cpm). See 23 for typical DD bearing life in a wet, reversing and alternating load test environment.

Current applications for the D and DD liners include landing gear shock struts, main and tail rotor pitch control link bearing, and damper bearings.

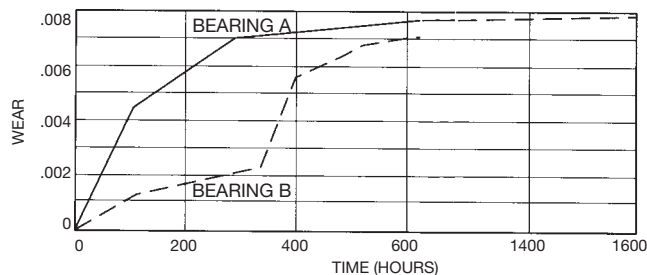

Test Conditions, DD Liner

Bearing	Ball Diameter	Race Width	Osc.	CPM	Stress	PV@	
						Max. Load	Contamination
A	1.500	.797	$\pm 10^{\circ}$	300	0 ± 2000 psi	26200	Water
B	1.500	.797	$\pm 10^{\circ}$	300	2000 psi ± 2000 psi	52400	Water

23 Typical Performance of the DD Liner System (Reversing Load)

Self-Lubricating Liner Systems

HS LINER SYSTEMS

NHBB's HS liner system consists of a TEFLON® and Polyester Weave coated with a high temperature thermosetting resin. The HS liner has a thickness of .014 (Ref.).

The HS liner was developed to accommodate rotary wing aircraft applications in which high speeds (approximately 300 to 1500 cpm) and light uni-directional loading (approximately 2,000 psi) conditions exist. See 24 for typical HS bearing life in a wet, uni-directional load test environment.

The DH liner is available for applications similar to HS but requiring a thicker liner .018 (Ref.). For additional information, please contact NHBB's Applications Engineering Department.

HIGH TEMPERATURE (HT) LINER SYSTEMS

NHBB HT liner systems are TEFLON® and fiberglass woven cloth that are impregnated with a high temperature polyimide resin. The HT liner is suitable for engine applications such as found in variable stators for fans and compressors, throttle linkages, vane guide sleeves and actuators in and around the engine. These applications require liner systems that can accommodate temperature up to 625°F. While the loading and motion are similar to fixed wing conditions, the high temperatures require a greater temperature resistant adhesive such as that used in the HT liners. The HT liner system is designed to meet higher operating temperatures but at reduced loads to

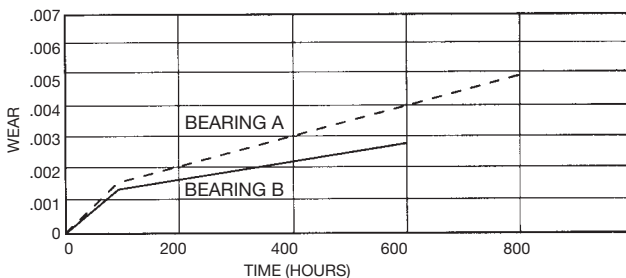

Test Conditions, HS Liner

Bearing	Ball Diameter	Race Width	Osc.	CPM	Stress	PV	Contamination
A	.656	.312	±6°	1500	2000 psi	34400	Water and dust
B	1.500	.797	±10°	300	2000 psi	26200	Water and dust

24 Typical performance of the HS liner system (uni-directional load)

those required for fixed wing applications (AS81820). 25 shows the typical performance of the HT liner system at 12500 psi loading at 550 to 625°F at 20 cpm.

HIGH TEMPERATURE COMPOSITES

NHBB offers a variety of stand alone self-lubricated high temperature polymer composite products. These lightweight, corrosion resistant products offer excellent friction and wear properties at temperatures up to 700°F which make them a top candidate for hostile environment applications such as jet-engine sleeves/bearings. These composite products are usually manufactured by molding a high temperature polyimide resin impregnated carbon/graphite prepreg into near net-shape components. Subsequential postcuring and machining is generally employed to attain final design configuration. These high temperature polymer composite products can also be molded to a metal-backed retainer. For additional information, please contact NHBB Applications Engineering Department.

DU LINER SYSTEM

The DU® liner system consists of a low carbon steel sheet coated with a mixture of TEFLON®, lead, and sintered bronze.

DU® lined bearings can be used in applications up to 550°F, but significant life-reduction factors must be applied.

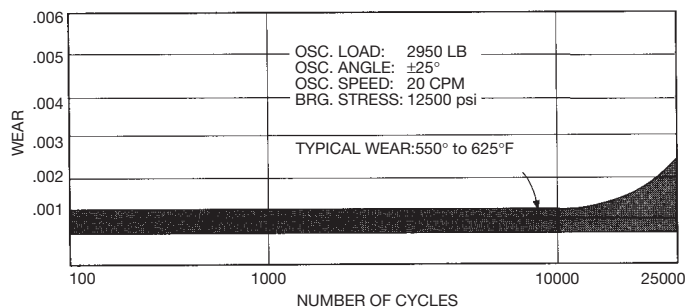

25 Typical performance of the HT liner system (oscillation under radial load, wear vs. life)

DU® is a registered trademark of The Glacier Metal Company Limited
TEFLON® is a Du Pont registered trademark



CHARACTERISTICS OF SELF-LUBRICATING TEFLON®-LINED BEARINGS

1. Modulus of elasticity: 4.5×10^5 psi.
2. Coefficient of thermal expansion: 11.6×10^{-6} in/in/°F.
3. Low coefficient of friction ranging from approximately .02 to .10. As shown in 26, the coefficient decreases as load and temperatures increase. However the coefficient also increases as surface speed and mating surface roughness increase.
4. Non-corrosive.
5. Resistant to most chemicals, greases and oils, however wear rates may increase when movement takes place under contaminated conditions.
6. Non-conductive and non-magnetic.
7. Wear rates remain low and relatively constant after an initial run-in period.
8. Continues to function satisfactorily with wear as high as .010.

TORQUE

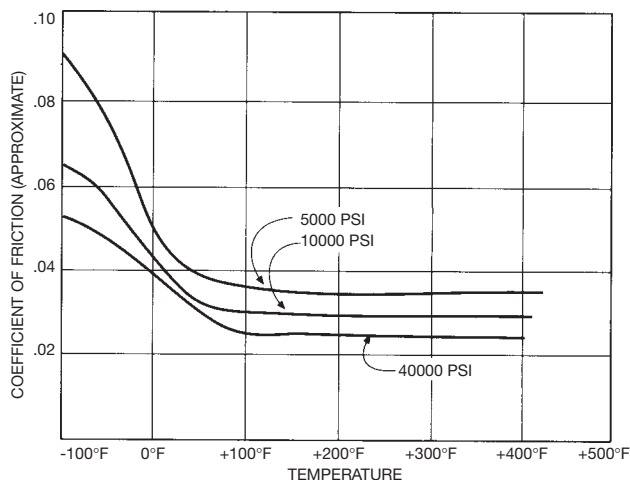

26 Effect of temperature and load on coefficient of friction

TEFLON®-lined spherical bearings are typically specified with preload between the ball and race in terms of no load rotational breakaway torque (inch-pounds or inch-ounces). This is the torsional force required to initiate rotation between the ball and race. Bearings can also be manufactured with a misaligning torque requirement.

The standard method for checking no-load rotational breakaway torque is described in Military Specification AS81820. The procedure is to hand-rotate the ball to initiate movement. Then the race is locked on a torque meter. The outer race is held in such a manner as to minimize bearing distortion and the resultant effect on the bearing preload. Torque is gradually applied to the ball. The torque required to start the ball moving is then recorded.

NHBB uses the same method to check torque, except that the ball is locked on the torque meter and the race is rotated.

Breaking the ball free from the race before checking torque is very important. Because of preload between the ball and race, the liner, under compression, slowly conforms to the microscopic surface irregularities of the ball. To initiate rotation after a period of time, all of the microscopic liner projections into the ball surface must be sheared off. Once this has been accomplished, the torque reverts back to its rated value. All torque testing should be performed with the outer race restrained in such a manner as to minimize bearing distortion and the resultant effect on the torque reading obtained. Torque readings can vary appreciably as the result of incorrect or excessive clamping, presence of contaminants, excessive speeds and differences in atmospheric conditions.

Rotational Breakaway Torque is the highest value attained just prior to ball movement. The ball should be hand rotated through several revolutions immediately before testing.

Rotational Torque is the value required to maintain 2 rpm rotation of the ball about its centerline.

Misalignment Torque is the value required to move the ball in a mode other than rotation about the bore centerline.

Self-Lubricating Liner Systems

TORQUE CALCULATION

The prediction of spherical bearing torque is more difficult than that of rolling element bearings. Friction coefficients of the sliding surfaces in these bearings vary depending on temperature and load. Torque at various loads is estimated by using the following formula:

$$T = \mu \times F \times R$$

Where:

T = torque, lbf-in

μ = friction coefficient (26)

F = load in lbf

R = one-half of ball diameter for spherical bearings turning on ball; or one-half the bore diameter for plain journal bearings or spherical bearings turning on bore

SURFACE FINISH AND HARDNESS

Surface finish and hardness for the surfaces running against a TEFLON® liner are important for maximum liner life, whether on the shaft, ball, or other running surface.

For maximum life, NHBB recommends a finish of 8 R_a maximum, achieved by lapping, buffing, or honing after grinding. Anything higher than 8 R_a will reduce life.

Hardness should be R_C50 minimum. As hardness drops below R_C50 , the mating surface begins to wear.

GAGING LINED BORES

Conventional bore measuring equipment such as air gages, inside micrometers, etc., will often indicate an apparent oversize condition when used in measuring fabric-lined sleeve bores. Texture and resiliency of the fabric liner, as well as the contact pressure exerted by the gaging instruments all contribute to the probability of obtaining a false reading.

The most widely accepted method for inspecting lined sleeve bores is with the use of functional plug gages (see 27). The diameter of the “go” member should be the minimum bore diameter specified and that of the “no-go” should be the maximum bore diameter specified. The “go” member should enter freely or with light to moderate force. The “no-go” member should not enter with light force but entry under moderate to heavy force is acceptable.

All edges of gage members should have a radius of .03 minimum, and surface finish of the gage should not exceed 8 R_a in order to prevent damage to the fabric when inspecting.

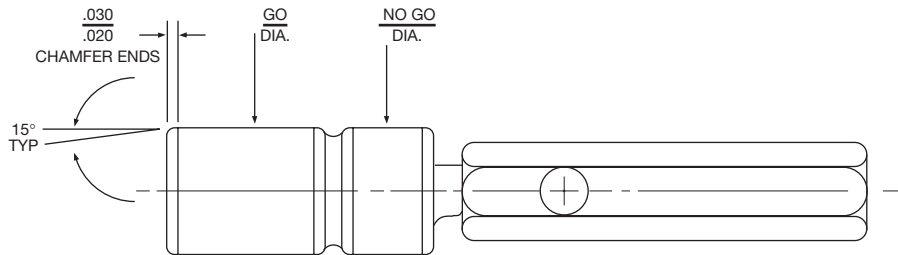

27 Plug Gage



FACTORS AFFECTING THE SELECTION, PERFORMANCE AND EVALUATION OF TEFLON® LINED SPHERICAL, ROD END AND SLEEVE BEARINGS

An answer to situations where the performance envelope cannot be covered by metal-to-metal bearings is to consider TEFLON® lined bearings. Here, the lubricant configuration is such that it functions as the load carrying element of the bearing, as represented by the liner systems currently in use. TEFLON® bearings may be specified under all or some of the following situations:

1. Where lubrication is undesirable, difficult to perform, or impossible.
2. Where loads are high and angular movement is low.
3. Where space is limited.
4. Where vibration is present.
5. Where temperature of the environment renders greasing unfeasible.
6. Where a joint must remain static for an extended period of time before movement is initiated.
7. Where friction in a greased bearing would be so high as to render the joint area useless after a limited number of cycles or impose an unacceptable fatigue situation.
8. Where, in static joints, fretting is a problem.

While TEFLON® lined bearings can do an excellent job in many areas, there have been areas of misapplication. Also, there exist some misunderstandings regarding life and failure as applied to hardware of this type. Following are important clarifications concerning these products:

1. The TEFLON® lined bearing starts life with a finite rotational pre-load torque or clearance.
2. This rotational pre-load torque always decreases with bearing usage and clearance always increases with usage.
3. A bearing may be said to have failed if the rotational pre-load torque drops below some specified value. This is always a systems application characteristic.
4. A bearing may be said to have failed when the clearance generated by wear exceeds some specified value. This, again, is always some specified systems characteristic.
5. A bearing may be said to have failed if the liner wears through enough to permit the ball to contact the race.

6. No bearing, including TEFLON® lined bearings, will last forever. The “lifetime” lubrication concept applies to the bearing alone, not to the end usage item.
7. The presence of liner debris on a bearing is not a definitive indication of failure.
8. TEFLON® lined bearings tend to telegraph their impending failure by increased radial and axial play.

When evaluating the probable service life of a TEFLON® lined bearing application, there are some factors that do not appear in the $PV = K$ relationship, (see page 82). Some considerations for a given application might include:

1. Surface sliding speed
2. Maximum ambient temperature
3. Size of the heat sink
4. Acceptable friction levels
5. Load per unit of area, or liner stress level
6. Mode of load application; i.e., the duty cycle
7. Service alignment accuracy, particularly with respect to sleeve and flanged bearings
8. Surrounding atmosphere
9. Tolerable wear rate
10. Surface finish of the bearing mating shaft and the shaft material

Cost is not included in the above list since it does not affect the serviceability of any bearing. Higher individual bearing costs may result in a more economical or lower priced finished assembly.

Grease and Dry Film Lubricants

TABLE 4: Grease Lubricants

Type	Specification	Composition	Temperature Range	Use and Remarks
Grease, aircraft and instrument, gear, and actuator screw	MIL-PRF-23827	Lithium soap, ester oil, anti-rust and E.P. agents	-100° to +250°F	General purpose grease. Extreme pressure (E.P.) properties, good water resistance
Grease, MoS ₂ , for high and low temperatures	MIL-G-21164	Same as MIL-PRF-23827, except 5% MoS ₂ added	-100° to +250°F	Similar to MIL-PRF-23827 but has added MoS ₂ for extra E.P. properties and anti-wear action under marginal lubrication conditions
Grease, Aircraft	MIL-PRF-81322	Synthetic oil and thickener	-65° to +350°F	High temperature grease

The selection of lubricants is based on bearing materials, design, environment, and operating conditions. The following sections describe grease and dry film lubricants and list the most commonly used types.

Grease

Grease is an oil to which a metallic soap, synthetic filler, thickener, or a combination of these has been added to prevent oil migration from the lubrication site. The operative properties of grease depend almost wholly on the base oil.

Grease lubricants can be used on metal-to-metal spherical and rod end bearings such as a steel ball against a steel race, a steel ball against an aluminum bronze race, and a beryllium copper ball against a steel race.

The three most common grease lubricants used with NHBB bearings are shown in table 4. Grease-lubricated bearings are usually furnished with lubrication holes and grooves, and, in the case of rod ends, lubrication fittings for periodic relubrication. These bearings have a tendency to gall unless lubrication is very frequent and loads are reversing so that the grease is not squeezed out of the load area.

In applications with uni-directional loading, the grease will quickly be squeezed out of the bearing area. In these applications, dry film can be used. The use of TEFLON® also should be investigated.

NHBB grease lubricants are suitable for most airframe applications. If bearings will be required to operate in unusual conditions (for example, high vacuum, radiation, or near chemicals such as phosphate ester fluids or propellants), please consult the NHBB Applications Engineering Department before ordering.

28 illustrates a lubrication network which provides for lubricating both the ball/race and the ball/shaft (or pin) interfaces.

Further, relubrication can be accomplished via the race housing or the ball shaft or pin. If

relubrication is to be done via the race housing, and no lubrication is required in the ball bore, lube holes and I.D. lube groove in the ball may be omitted.

Conversely, if relubrication is to be done via the shaft or pin, lube holes and O.D. groove in the race may be omitted.

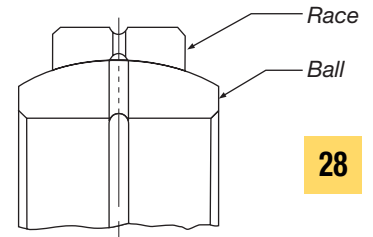

28

29 shows a transverse lube groove configuration for use on medium to large size spherical bearings in critical applications where lubrication

demands are more extreme. The transverse grooves are machined into the cylindrical race blank prior to swaging. These bearings are often bushed with copper alloy sleeves which in turn may incorporate transverse or equivalent lube groove patterns to provide for maximum possible lubrication.

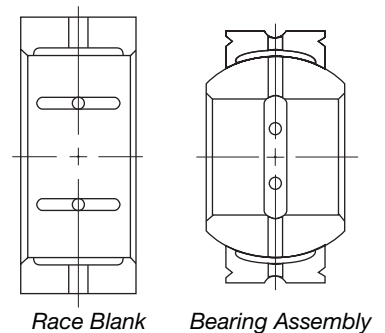

29 Lube Groove Size and Depth Exaggerated for Clarity

TEFLON® is a Du Pont registered trademark



TABLE 5: Dry Film Lubricants

Type	Specification	Lubricant	Binder	Temperature Range	Use and Remarks
Solid film, heat cured, corrosion inhibiting	MIL-L-46010 Type I	MoS ₂ (no graphite or powdered metals), and corrosion inhibitors	Organic resins	-65° to +450°F	Good wear life. Used for most bearing applications other than extreme temperature situations
Solid film, heat cured, corrosion inhibiting	MIL-L-46010 Type II	MoS ₂ (no graphite or powdered metals), and corrosion inhibitors	Organic resins	-90° to +400°F	Similar to MIL-L-46010, TY I except that it will provide added corrosion protection to substrate. Must have phosphate coating pretreatment for effective use on steel
Solid film, extreme environment	MIL-PRF-81329	MoS ₂ and other solid lubricants	Inorganic binders	-300° to +1200°F	To be used in extreme environments, i.e., vacuum, liquid oxygen, high temperatures. Wear life not as good as resin-bonded types

DRY FILM

Dry film lubricants consist of MoS₂ and small quantities of other materials such as graphite or powdered metals. These are bonded to the bearing race I.D., and often the ball O.D. and bore, by either organic resins or inorganic binders (phenolic, sodium silicate, or other glass compositions). Hardening or curing is achieved by baking at temperatures ranging from 300° to 1000°F depending upon the binding material.

NHBB can apply dry film lubricants to all metal-to-metal spherical and rod end bearings.

The three most common dry film lubricants used with NHBB bearings are shown in table 5. The advantages of dry film include good tenacity, low coefficient of friction (0.05 to 0.25), and resistance to high bearing pressure (up to 90000 psi on hard substrates). Dry film, however, is not as predictable as TEFLON® liners regarding wear characteristics.

30 illustrates the difference in bearing life between dry film lubricated bearings and bearings that have not been lubricated.

NHBB dry film lubricated bearings are generally used in aircraft and engine applications in which extreme temperature conditions exist (-300° to +1200°F).

30

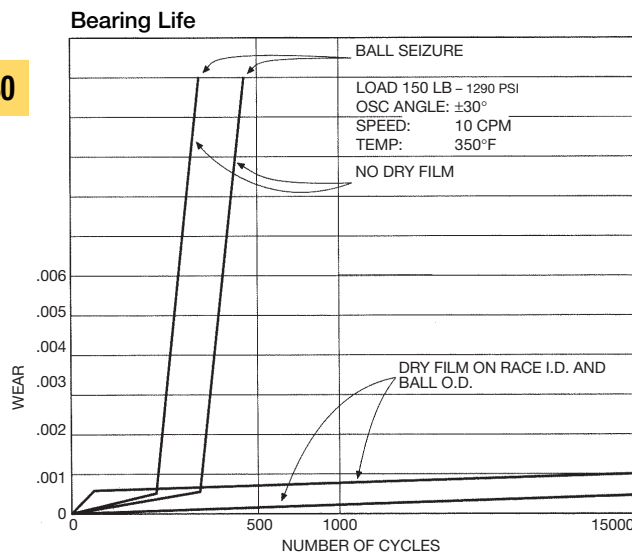

Dry Film Lubricated vs. Non-Lubricated Bearings

Commonly Used Dry Films

Product	Specification	Temperature Range
E/M® 967		-300° to +750°F
Lubeco M-390	MIL-L-46010, TY I	-65° to +500°F
Surf-Kote® LBO-1800-G		-65° to +1100°F
Molykote® 106		-321° to 450°F
Everlube® 811	MIL-PRF-81329	-300° to +1200°F
Vitrolube 1220		-400° to +700°F

TEFLON® is a Du Pont registered trademark
 EVERLUBE® is a registered trademark of The Morgan Crucible Company PLC
 E/M® is a registered trademark of The Morgan Crucible Company PLC
 MOLYKOTE® is a registered trademark of Dow Corning Corporation
 SURF-KOTE® is a registered trademark of Hohman Plating & Mfg. INC.

Locking Devices, Keys and Keyways

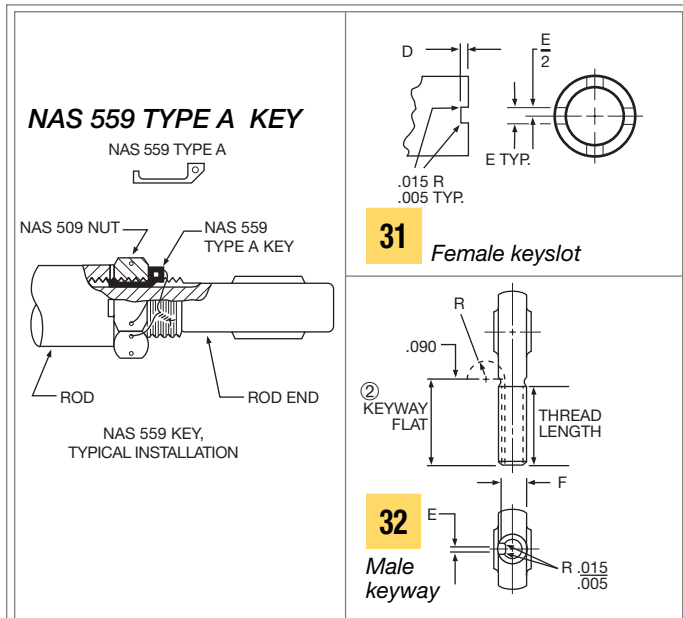

Notes:

NAS 559 TYPE A KEY

- ① The keyways and keyslots used in conjunction with these keys are shown in 31 and 32. The NAS 559 keys are available for thread sizes 1/4 through 2-1/4 inches.
- ② Keyway flat may vary from standard on smaller size rod ends but shall extend at least beyond minimum thread length in all cases.

Thread Size	(D) +.005 - .000	(E) +.005 - .000	(F) +.000 - .005	(R) ±.010
.250	.056	.062	.201	.255
.312	.056	.062	.260	.255
.375	.056	.093	.311	.255
.437	.069	.093	.370	.255
.500	.069	.093	.436	.255
.562	.077	.125	.478	.255
.625	.077	.125	.541	.255
.750	.077	.125	.663	.255
.875	.086	.156	.777	.318
1.000	.094	.156	.900	.318
1.125	.094	.187	1.010	.382
1.250	.116	.187	1.136	.382
1.375	.116	.250	1.236	.445
1.500	.116	.250	1.361	.445
1.625	.129	.250	1.477	.445
1.750	.129	.312	1.589	.508
1.875	.129	.312	1.714	.508
2.000	.129	.312	1.839	.508
2.125	.129	.312	1.955	.508
2.250	.129	.312	2.080	.508

Keys as represented here are metallic locking devices which, when assembled into keyways and keyslots, prevent relative motion between mating components of bearing linkage assemblies. NHBB does not manufacture keys, nuts or lock wire as separate items. These items are readily available from other sources. Keyways and keyslots are optional. To specify, add suffix "W" to NHBB catalog rod end part number.

AS81935 KEY

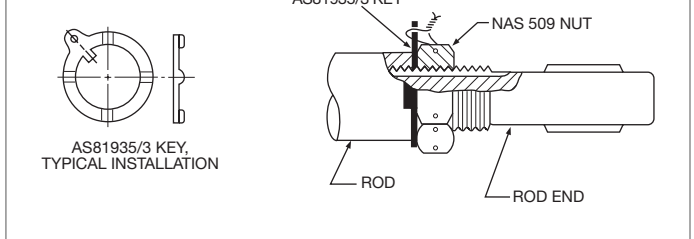

33 Female keyslot

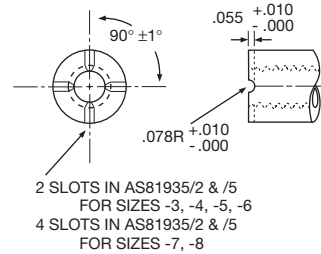

34 Male keyway

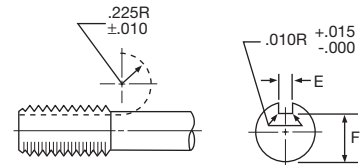

Notes:

AS81935 KEY

- 1. AS81935/3 keys are used on AS81935 sizes -3 through -8 when optioned. The keyways and keyslots used in conjunction with these keys are shown in 33 and 34.
- ② AS81935/3 keys are available for thread sizes 1/4 through 1/2 inches.

Thread (Male)	(E) +.005 - .000	(F) +.000 - .005
1/4-28UNJF-3A	.062	.207
5/16-24UNJF-3A	.062	.268
3/8-24UNJF-3A	.093	.319
7/16-20UNJF-3A	.093	.383
1/2-20UNJF-3A	.093	.445



NAS 513 KEY

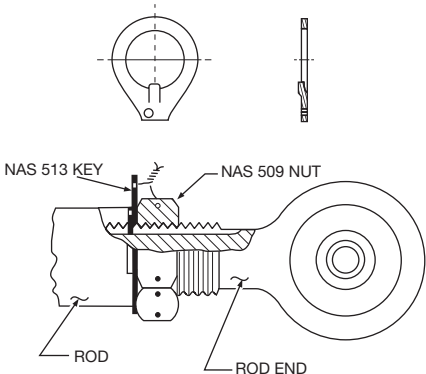

Thread Size ③	(D) +.005 - .000	(DD) ② +.005 - .000	(E) +.005 - .000	(F) +.000 - .005
.250	.056	.110	.062	.201
.312	.056	.110	.062	.260
.375	.056	.110	.093	.311
.437	.069	.110	.093	.370
.500	.069	.110	.093	.436
.562	.077	—	.125	.478
.625	.077	.125	.125	.541
.750	.077	.125	.125	.663
.875	.086	.156	.156	.777
1.000	.094	.156	.156	.900
1.125	.094	—	.187	1.010
1.250	.116	—	.187	1.136
1.375	.116	—	.250	1.236
1.500	.116	—	.250	1.361
1.625	.129	—	.250	1.477
1.750	.129	—	.312	1.589
1.875	.129	—	.312	1.714
2.000	.129	—	.312	1.839
2.125	.129	—	.312	1.955
2.250	.129	—	.312	2.080

(DD optional) ②

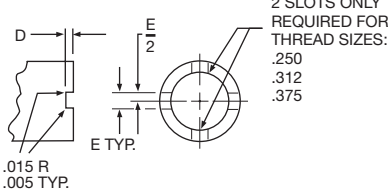

35 Female Keyslot

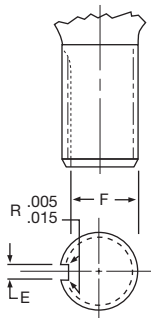

36 Male Keyway

Notes:

NAS 513 KEY

- 1. NAS 513 keys are used on AS81935 sizes -10 through -16 rod ends when optional. The keys and keyslots used in conjunction with these keys are shown in **35** and **36**.
- ② For female rod ends with deep square slot keyslot option AS81935 designation "W", the slot depth is modified as detailed in **35**. This deep slot "W" is also compatible with NASM14198, SAE-AS14227, NAS 1193 and NAS 559 keyways.
- ③ NAS 513 keys are available for thread sizes 1/4 through 2-1/4 inches.

NAS 1193 KEY

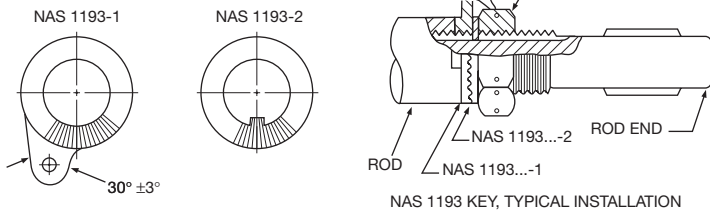

Notes:

NAS 1193 KEY

- 1. NAS 1193 keys are for positive indexing. They are used in applications in which a fine adjustment is required, within .001.
- 2. These keys can be used in conjunction with NAS 513, NAS 559 and AS81935/3 keyways or keyslots and are available for thread sizes 1/4 through 2-1/4 inches.

Sealed Bearings

For applications in which airborne or fluid contaminants threaten the useful life of spherical or rod end bearings, NHBB offers a combination metal shield and silicone seal to isolate and protect bearing surfaces.

The NHBB sealing system (37) comprises a pair of .010 (Ref.) stainless steel (or any other compatible weldable metal) shields and molded wedge-shaped silicone rubber seals. This seal system design does not significantly increase the weight of the bearing.

The shields are welded to the outer race of the bearing so that the seals are seated at the juncture of the ball and the race. As ball movement occurs, the seals wipe contaminants from the ball surface. This self-cleaning action prohibits most contaminants from reaching the load bearing area. Seals do not reduce the load bearing area or change the load rating of a bearing.

NHBB sealed bearings have been subjected to extensive dynamic testing by major aircraft manufacturers for resistance to contamination by MIL-H-5606 hydraulic oil and SAE AS 8243 de-icing fluid. Sealed bearing wear after 25,000 cycles was considerably less than unsealed bearing wear.

NHBB can seal any size metal-to-metal or self-lubricated bearing. The seal typically does not affect external mounting dimensions or dimensionally affect function on V-groove installations. Form, fit, and function interchangeability are maintained. However, a seal does reduce misalignment capability. NHBB seals can be used with bearings having staking grooves in the outer race, as well as with bearings having chamfered outer race configurations. For information on seal damage prevention when installing in counter bores that may contact the race face, contact NHBB Applications Engineering.

Sealed TEFLON® Lined Bearing

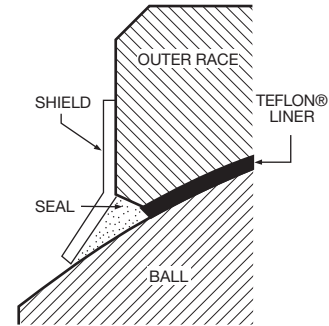

Recessed Seal Design

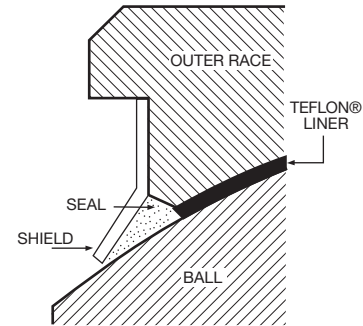

Sealed Metal to Metal Bearing

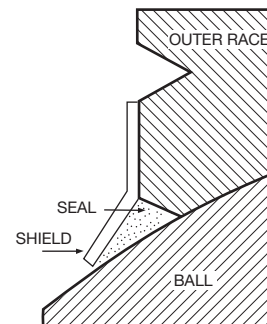

37 NHBB Bearing Seal



Bearing Installation and Retention

Installation and retention details are important considerations when designing a bearing. Features such as pins or bolts, housings, corrosion resistance, installation method, and retention methods must be considered to ensure optimum bearing performance.

38 This typical bearing installation, which is staked into the housing, is assembled with a mating clevis, bolt, nut, washers, and plain and flanged bushings.

In most applications, the bolt is preloaded with the nut to clamp up the ball and force the ball to rotate on the race I.D. Caution must be exercised when clamping the ball. Excessive force expands the ball and will bind it in the race. If the ball is not clamped up, motion will usually take place on the bore, in which case the bolt, the bearing bore, or both must have suitable surfaces for this motion.

THE PIN OR BOLT

In addition to carrying the structural loads through the joint, the pin or bolt may function as a journal, and must therefore meet the multiple requirements of adequate strength, minimum wear, low friction, and corrosion resistance. In these instances, the following provisions for relubrication should be made:

1. TEFLON® line the bearing bore or the pin or bolt O.D.
2. Dry film the bearing bore and/or the pin or bolt O.D.
3. Introduce lubrication holes and grooves in the pin or bolt or the ball members

Suggested pin materials are 17-4PH and PH13-8Mo stainless steel, and 4130/4340 steel chrome plated .002 thick. Pins, either bare or plated, should be heat treated to the required shear strength (108,000 psi Ref.) and ground and polished to the required dimensions with a surface finish of 8 R_A or better. The recommended fit between the pin or bolt and the bearing bore is line-to-line to .001 loose.

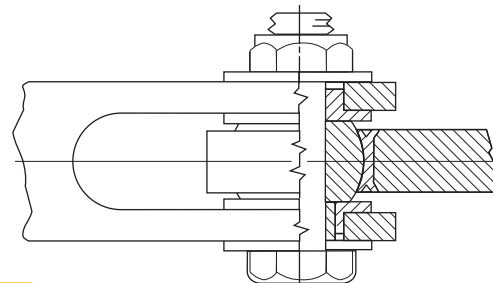

38 Typical Bearing Installation

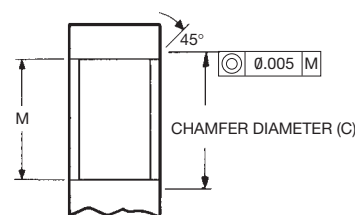

39 Chamfered Size Calculation for V-Groove Retention

Chamfer Dia.

$$(C) = M + [T - H + (2 \times E)]$$

(Tolerance + .008/ - .007)

T = average housing thickness

H = average outer race thickness

E = average V-groove depth in race,
depending on groove.

V-Groove Size*	Avg. Groove Depth (E)
A	.023
B	.033
C	.053
D	.073

*See **46** for groove dimensions, page 75.

Bearing Installation and Retention

HOUSINGS

The housing into which the bearing is mounted must be designed to ensure the structural integrity of the bearing. The recommended housing dimensions are as follows:

1. Bearing-to-housing fit: .0002 tight to .0008 loose.
2. Bore finish: 32 R_a .
3. Round within the bore diametral tolerance.
4. Bore aligned perpendicular to housing faces within .002 for sleeve bearings only.
5. Housing width: .005 tolerance (for staking purposes).
6. For V-groove retention the housing bore is chamfered. Chamfer size is calculated as shown in 39, page 71.
7. For housing stake and bolted plated retention, break edges .005 max on both sides.

The recommended shaft and housing sizes are based on an operating temperature range of -65° to 350°F. At elevated temperatures, allowances must be made for different coefficients of expansion for the various shaft, bearing, and housing materials. In general, the mating components should be adjusted to provide the recommended fit at operating temperature. In addition, internal bearing fit-up between the ball and race may be required (either additional internal clearance or decreased torque) to ensure proper operation over a broad temperature range.

The use of heavy interference fits between a bearing and housing is not generally recommended because it reduces internal clearance. If the application requires a heavy interference fit, the assembly of the bearing and housing must be accom-

plished by use of temperature differentials to prevent galling of the bearing or housing. The temperature differentials are dependent on the amount of press fit. After assembly, the bearing usually cannot be replaced because of galling during pushout. When using interference fits, the internal ball to race fit-up must allow for the contraction of the race (which can be up to 100% of the interference fit, depending on housing material, heat treatment, and size). For fit-ups on sleeve bearings see pages 47 and 49.

CORROSION RESISTANCE

A bearing, housing, or shaft interface is a likely place for various forms of corrosion to develop. Corrosion may be initiated or accelerated by wear (fretting) or caused by the galvanic action of dissimilar metals in the presence of an electrolyte. Control of galvanic corrosion can be established by isolating and protecting the active metal surfaces. When corrosion resistant materials are used for bearings, pins or bolts and housings, there is little problem with galvanic corrosion. When dissimilar, noncorrosion resistant materials are used, precautions must be taken to protect bearings, shafts, and housings used in contact with other metals or with the atmosphere. Table 6 shows various bearing, shaft, and housing materials, with finishing precautions necessary to combine them to make a complete design. In addition to these recommendations, the bearing O.D. and housing bore are sometimes coated with zinc chromate primer according to TT-P-1757, epoxy primer according to MIL-PRF-23377, or sealant according to MIL-PRF-81733.

TABLE 6: Treatments to Prevent Galvanic Corrosion

Bearing Material (Bore and O.D. Surface)	Housing or Shaft Material				
	Aluminum Alloys	Low Alloy Steels	Titanium	Corrosion Resistant Steels	Super-Alloys
Aluminum alloys	A	A, C	A	A, C	A, C
Bronze and brass	A, C	C	S	S	S
Bronze and brass cadmium plated	A	C	—	S	S
52100 and low alloy steels	A, C	C	—	C	C
440C stainless steel	A, C	C	S	S	S
440C with wet primer	A	C	S	S	S
Corrosion resistant steels, 300 series (17-4PH, 15-5PH, PH 13-8Mo, etc.)	A, C	C	S	S	S
Superalloys (Rene 41®, etc.)	A, C	C	S	S	S

— = Incompatible A = Anodize aluminum per MIL-A-8625, Type II, or Alodine per MIL-C-5541

C = Cadmium plate per Fed-Spec QQ-P-416

S = Satisfactory for use with no surface treatment required



INSTALLATION

The installation of a bearing or sleeve into a housing bore is a simple operation when done properly. Alignment of the bearing or sleeve to the housing bore is critical to prevent a cocking motion during insertion, which can damage or ruin the bearing or housing. Temperature differential installation is recommended.

SPHERICAL BEARING INSTALLATION

Use of an arbor press or hydraulic press is recommended. Under no circumstances should a hammer or any other type of shock-inducing impact method be used. A suitable installation tool (as shown in 40) is advised. A guide pin aligns the ball in a 90° position, but all force is applied to the outer race face only. A lead chamfer or radius on either the bearing or housing is essential.

LINED SLEEVE BEARING INSTALLATION

The same general procedure as outlined for spherical bearings should be followed (see 41). In the case of fabric lined bores, however, it is mandatory that both the insertion tool guide pin and the mating shaft have ends free of both burrs and sharp edges. A .030 (min.) blended radius or 15° lead (as shown in 41) is recommended, since it is virtually impossible to install a sharp edged shaft without inflicting some damage to the fabric liner. For maximum support of the fabric lined bore, the effective length of the insertion tool guide pin should exceed the sleeve bearing length.

RETENTION METHODS

Bearing retention in a housing can be accomplished by any one of the methods listed in table 7. To determine the best method, several factors must be taken into account, such as

effect on bearing internal clearance and torque, effect on housing residual stress, thermal expansion, added space and weight, retention capability, housing damage during bearing replacement, and number of times a bearing can be replaced.

The four retention methods listed in table 7 are the most commonly used. Other methods do exist, such as adhesive bonding, snap rings, and threaded cover plates, but they should be used only as a last resort.

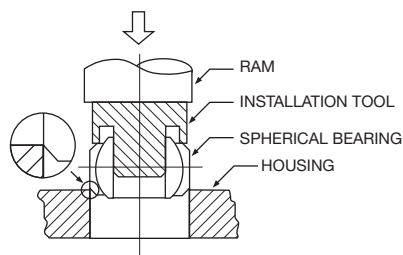

40 Spherical Bearing Installation

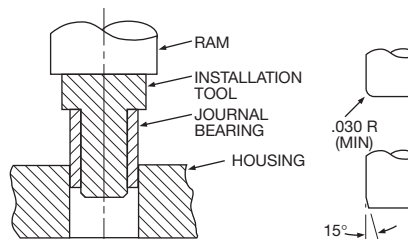

41 Sleeve Bearing Installation

TABLE 7: Characteristics of Recommended Retention Methods

Method	Effect on Bearing Internal Clearance	Effect on Housing Residual Stress	Added Space and Wt.	Retention Capability Requirements	Can Replacement Damage Housing?	Possible No. of Replacements
Threaded Bearing Retainer	None	None	None	Medium	No	No limit
Bolted Retainer	None	None	High	High	No	No limit
V-Groove Stake	None	None	None	Medium	No	No limit
Housing Stake: Continuous or Interrupted	High	High	None	Low	Yes	None

Bearing Installation and Retention

THREADED RETAINER RETENTION

Threaded bearing retainers, as shown in 42, offer an excellent bearing retention method due to ease of bearing replacement, high axial thrust load capabilities, and ease of assembly in areas where accessibility to conventional staking would be difficult.

BOLTED PLATE RETENTION

For high retention capability and ease of bearing replacement, the bolted plate method, as shown in 43, is recommended. However, space requirements and weight will increase.

HOUSING STAKE RETENTION

Housing stake retention, as shown in 44, has many shortcomings when compared to V-groove staking. The major consideration is race contraction, which adversely affects internal fit-up. Housing stake retention should be used only when there is insufficient space on the race face for a V-groove or the race material is not ductile. When mounting, the bearing and its housing are supported by an anvil while the staking tool is forced into one side of the housing near the edge of the bearing. This action displaces a small amount of the housing material over the race chamfer. The opposite side of the housing is then staked in the same manner.

V-GROOVE RETENTION

V-groove retention, as shown in 45, is the most widely used and recommended. The bearing outer race has a small groove machined into each face, which leaves a lip on the race O.D. corners. With the use of staking tools, these lips are swaged (flared) over the chamfered edges of the housing.

The prerequisites for good V-groove staking are proper size housing chamfers, staking tools that match the V-groove size, and the availability of a hydraulic or pneumatic press capable of applying the staking force. To use V-groove staking successfully, the following conditions must be met:

1. Race hardness: R_C40 max.
2. Sufficient space on the race face for machining a groove.
For V-groove sizes, see 46.
3. V-groove size capable of carrying the axial load, see 47.

STAKING PROCEDURE

1. Install bearing into housing per 40 and position it symmetrical about housing centerline within .005.
2. Mount bearing and top anvil over bottom anvil guide pin as shown in 45.
3. A trial assembly should be made for each new bearing lot to determine the staking force necessary to meet the axial retention load required. Excessive force should be avoided since this may result in bearing distortion and seriously impair bearing function and life. (See table 8 for recommended Staking Force, page 75).
4. Apply the staking force established by trial assembly, rotate assembly 90° and re-apply force.
5. After staking, a slight gap may exist between race lip and housing chamfer as shown in detail in 45. This gap should not be a cause for rejection providing the bearing meets the thrust load specified.

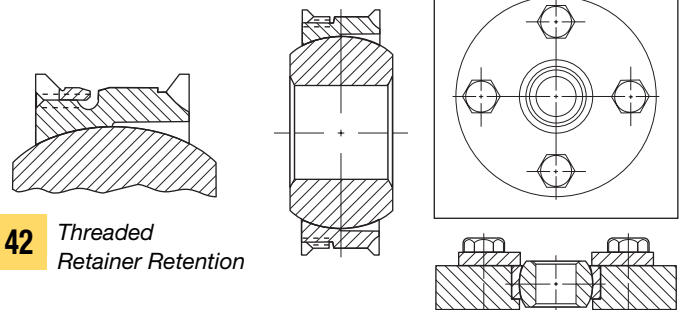

42 Threaded Retainer Retention

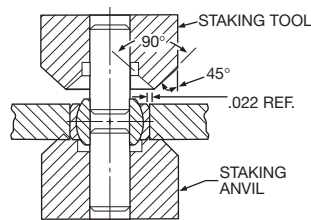

44 Housing Stake Retention

43 Bolted Plate Retention

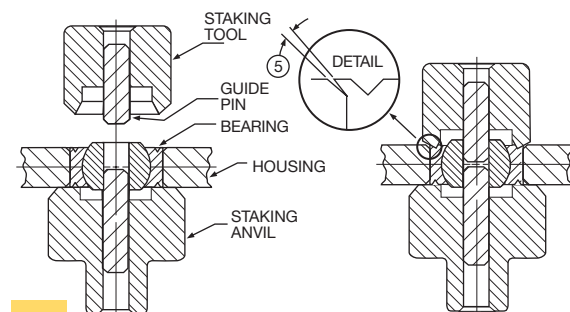

45 V-Groove Staking Method



STAKING FORCE

The staking force equals the product of the bearing O.D. and a constant for each groove size (see table 8). For example, a bearing with a "B" size V-groove and 1.500 O.D., the staking force will be 1.500 X 12,000 lbs. = 18,000 lbs.

These staking forces are valid for outer race materials having an ultimate tensile strength of 140,000 psi.

Staking forces for other materials are proportional to the ultimate tensile strength of the materials as compared to 140,000 psi.

These staking forces should be used as a general guide to establish a starting point. Lower forces may be adequate or higher forces may be necessary depending on staking technique and axial load requirements.

As a rule, only the amount of force required to get the desired amount of retention should be used.

The use of proper fits and staking techniques should not cause significant changes in bearing preload.

As a minimum, the first and last article staked should be proof-tested. 48 shows a method for proof-testing staked bearings for axial retention. This is the generally accepted method for checking retention used by bearing and air frame manufacturers.

47 shows allowable design thrust loads for bearing O.D.'s. The loads shown should be obtainable using staking tools with 45° outside angles.

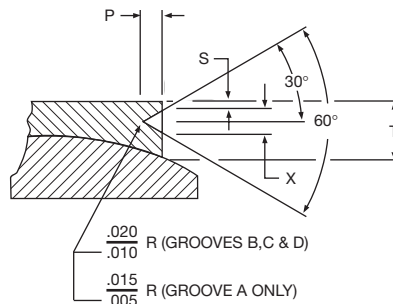

46 V-Groove Sizes

V-Groove Sizes

Groove Size	P +.000 -.015	S +.000 -.010	X +.000 -.010	T Min.*
A	.030	.020	.045	.075
B	.040	.030	.055	.125
C	.060	.030	.080	.156
D	.080	.045	.105	.188

*For TEFLON® lined bearings, add single liner thickness to "T Min."

TABLE 8: Staking Force

Groove Size*	Lbs.
A	7700
B	12000
C	17700
D	25800

*See 46 for groove sizes.

48 Staked Bearing Proof Testing Method

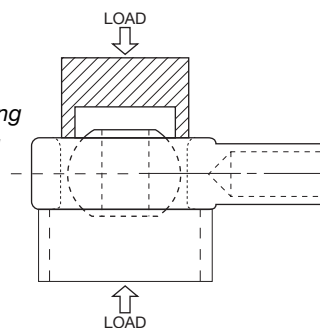

47 Thrust Loads Based on 46 Groove Types and Materials Specified.

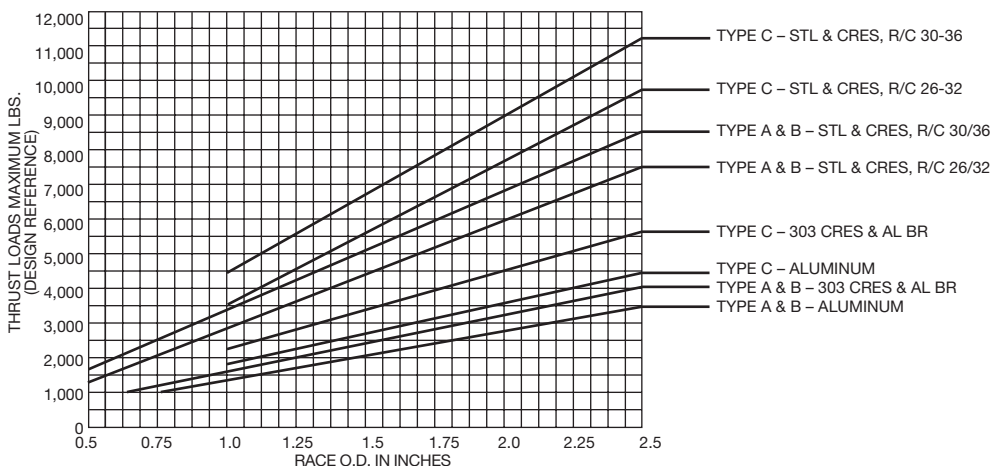

TEFLON® is a Du Pont registered trademark

Bearing Installation and Retention

V-GROOVE STAKING TOOL

The staking tool and staking anvil depicted in 49 and 50 are made from tough, hardenable tool steel (for example, A-2) and heat treated to R_C55 to 60. The critical dimension of the tools are as listed. As a final check on the staking tool and anvil, a

final layout drawing should be made to check fit-up. NHBB manufactures staking tools to meet many customers' needs. To obtain staking tools specially manufactured by NHBB, please refer to ordering information on page 77.

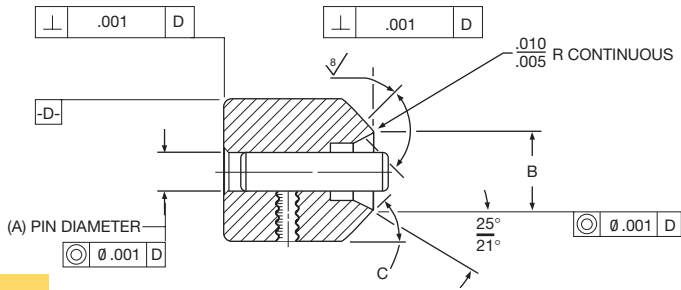

49 Staking tool design

- A = Ball bore min. - .001
(Tolerance + .000/ - .001)
- B = Bearing O.D. - 2 X Min. lip thickness - Min. groove width
(Tolerance + .005/ - .000. See 46 for lip thickness (page 75)
"S" and groove width "X".)
- C = Adequate stakes for most applications are obtained with staking tools having 45° to 50° outside angles. When required, secondary staking tools having an outside angle of 60° to 70° can be used to obtain maximum retention and to reduce the amount of gap between the housing chamfer and the lip of the outer race.

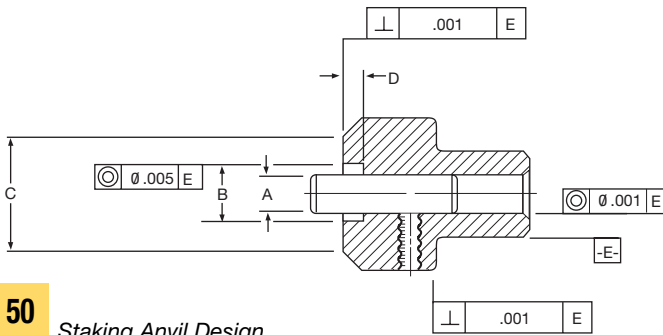

50 Staking Anvil Design

- A = Ball bore min. - .001
(Tolerance + .000/ - .001)
- B = $\sqrt{\text{Ball spherical dia.}^2 - \text{Race width}^2} + .030$
(Tolerance ± .010)
- C = $\sqrt{\text{Body head dia.}^2 - \text{Body width}^2}$
(Tolerance ± .010)
- D = $\frac{\text{Ball width max.} - \text{Race width min.}}{2} + .015$
(Tolerance ± .010)



Staking Tool Sets – Ordering Information

Hydraulic (Anvil) staking tools are available for all NHBB standard and special spherical bearings with staking grooves. Each set consists of one staking (flaring) tool and one staking anvil, both with guide pins installed. For spherical bearings in this catalog, order staking tool sets by the part numbers below.

For special (non-catalog) bearings or larger sizes, consult NHBB.

NHBB Part Number	Bore	Staking Tool Part Number
ADB()V	3	STN 0003
ADB()V(L)	4	STN 0004
HT()V(L1)	5	STN 0005
AG()V	6	STN 0006
AG()V300	7	STN 0007
HSBG()V	8	STN 0008
AHT()V	9	STN 0009
AHET()V	10	STN 0010
ABG()V(L)	12	STN 0012
ABG()V-501(L)	14	STN 0014
ADBL()V		
HTL()V(L1)		
ADW()V	3	STW 0003
AW()V	4	STW 0004
ADW()V(L)	5	STW 0005
WHT()V(L1)	6	STW 0006
ADWL()V	7	STW 0007
ADWL()V(L)	8	STW 0008
WHTL()V(L1)	9	STW 0009
	10	STW 0010
	12	STW 0012
	14	STW 0014
	16	STW 0016
ADBY()V	3	STY 0003
ASBY()V	4	STY 0004
ADBY()V(L)	5	STY 0005
	6	STY 0006
	7	STY 0007
	8	STY 0008
	9	STY 0009
	10	STY 0010
	12	STY 0012
	14	STY 0014
	16	STY 0016
	20	STY 0020
	24	STY 0024

EXAMPLES: NHBB P/N	STAKING TOOL
1. ADB10V	STN 0010
2. ABG8V (L)	STN 0008
3. ADW5V	STW 0005
4. ADBY6V	STY 0006

Load Ratings and Misalignment Capabilities

DEFINITIONS FOR ROD END AND SPHERICAL BEARING TERMINOLOGY

Radial Load

A load applied normal to the bearing bore axis (see 51A).

Axial Load

A load applied along the bearing bore axis (see 51B).

Static Load

The load to be supported while the bearing is stationary.

Dynamic Load

The load to be supported while the bearing is moving 52.

Static Radial Limit Load

That static load required to produce a specified permanent set in the bearing. It will vary for a given size as a function of configuration. It may also be pin limited, or may be limited as a function of body restraints as in the case of a rod end bearing. Structurally, it is the maximum load which the bearing can see once in its application without impairing its performance.

Static Radial Ultimate Load

That load which can be applied to a bearing without fracturing the ball, race or rod end eye. The ultimate load rating is usually, but not always, 1.5 times the limit load. Plastic deformation may occur.

Static Axial Limit Load

That load which can be applied to a bearing to produce a specified permanent set in the bearing structure. Structurally, it is the maximum load which the bearing can see once in its application without impairing its performance.

Static Axial Ultimate Load

That load which can be applied to a bearing without separating the ball from the race. The ultimate load rating is usually, but not always, 1.5 times the limit load.

Axial Proof Load

That axial load which can be applied to a mounted spherical bearing without impairing the integrity of the bearing mounting or bearing performance. It is always less than the static axial limit load. Bearing movement after proof load is usually .003 or less. See the Bearing Installation and Retention section for further information beginning on page 75.

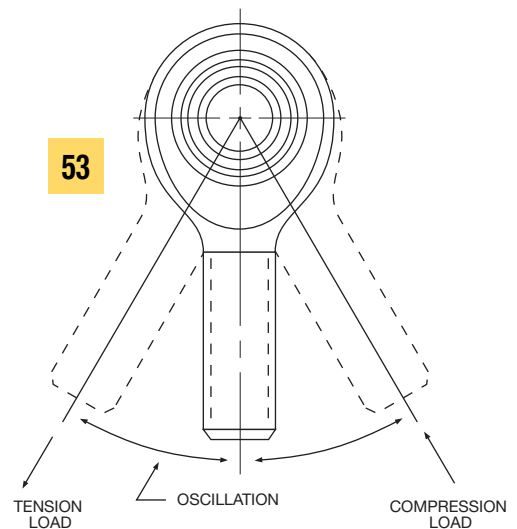
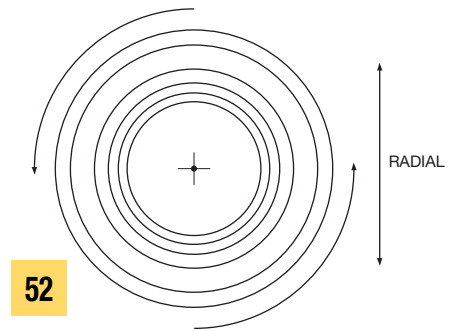
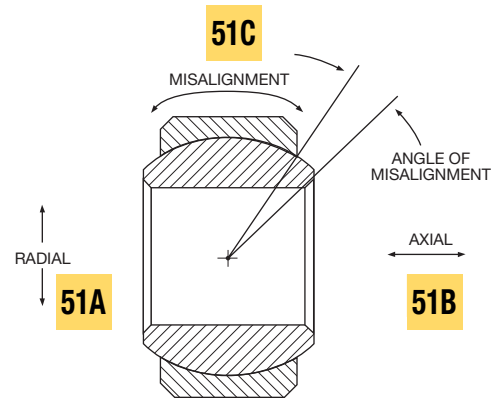



Rotation

Is the relative angular displacement between the ball and race that occurs within the plane perpendicular to the axis of the ball bore (see 53). The direction of rotation is about the axis of the ball bore.

Misalignment

Is the relative angular displacement between the ball and race that occurs within any plane that coincides with the axis of the ball bore (see 51C). The direction of misalignment is about any axis perpendicular to the ball bore.

Oscillating Radial Load or Dynamic Load

The uni-directional load produces a specified maximum amount of wear when the bearing is oscillated at a specified frequency and amplitude. This rating is usually applied to self-lubricating bearings only. The dynamic capability of metal-to-metal bearings depends upon the degree and frequency of grease lubrication, and that of dry film lubricated bearings upon the characteristics of the specific dry film lubricant applied.

Radial Play

Radial play (or radial clearance) is the total movement between the ball and the race in both radial directions less shaft clearance (when applicable). Industry specifications have established the gaging load at ± 5.5 lbs., and this is now considered as the industry standard (see 54 and 55). Unless otherwise specified, the industry wide standard for metal-to-metal spherical bearing and rod end radial clearance is "free-running to .002 max." Radial play is sometimes referred to as "Diametral clearance." The two terms are synonymous.

Axial Play

Axial play (or axial clearance) is the total movement between the ball and the race in both axial directions (see 56). The gaging load is again ± 5.5 lbs. Axial play is a resultant, being a function of radial play, of ball diameter and race width. The ratio between radial and axial play varies with bearing geometry.

Fatigue Load of Rod Ends

Aerospace Standard series rod end bearings AS81935 must be capable of withstanding a minimum of 50,000 cycles of loading when tested as follows: The loading must be tension-tension with the maximum load equal to the fatigue loads listed on the NHBB drawing of the ADNE and ADN series rod end bearings. The minimum load must be equal to 10% of the fatigue loads.

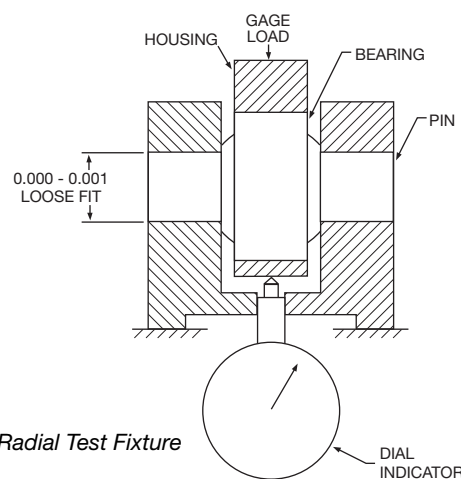

54

Radial Test Fixture

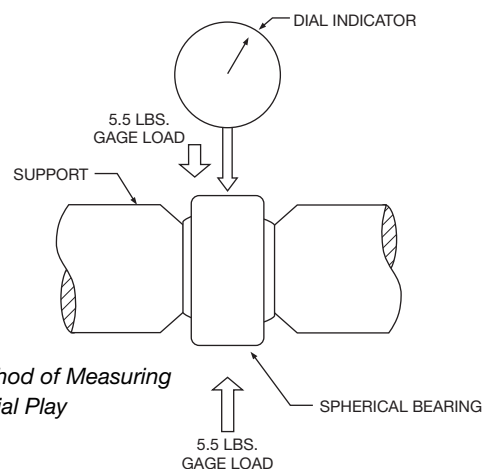

55

Method of Measuring Radial Play

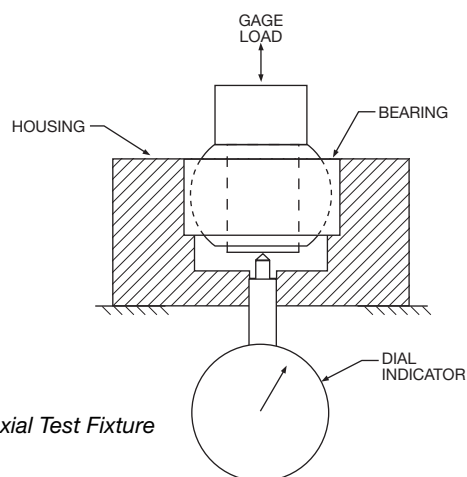

56

Axial Test Fixture

Load Ratings and Misalignment Capabilities

LOAD RATINGS

The load rating of a bearing is determined by the dimensions and strength of its weakest component. External factors, such as mounting components, pins, bolts, and housings are not considered part of a bearing when load ratings are investigated but should be considered separately.

SPHERICAL BEARING LOAD RATINGS

The weakest part, or load-limiting area, of a spherical bearing is its race. For this reason, formulas have been developed that use the race to calculate static load ratings based on size and material strength. The static load rating formulas for self-lubricating and metal-to-metal spherical bearings are shown in 57 and 58. These formulas will yield approximate ratings, which should be used as ballpark numbers for bearing design.

The allowable radial stress values given in the tables were determined from the ultimate tensile strength specifications for various race materials. Allowable axial stress values were derived from material yield strengths.

Allowable Stress - TEFLON®-Lined Bearings

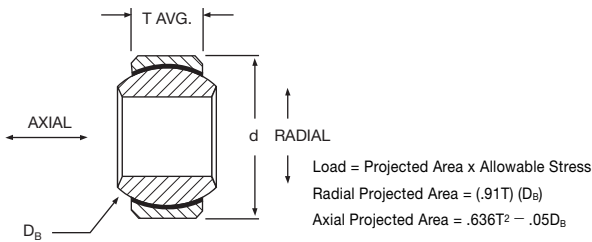

57 Static Load Rating Formulas for Self-Lubricating Spherical Bearings

Allowable Stress - Metal-to-Metal Bearings

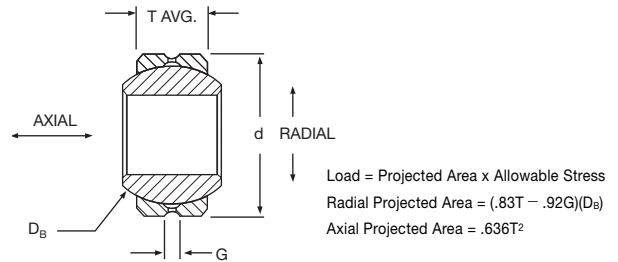

58 Static Load Rating Formulas for Metal-to-Metal Spherical Bearings

Allowable Stress TEFLON® Lined Bearings (psi)

Race Material	Radial		Axial	
	Ultimate	Limit	Ultimate	Limit
17-4PH, R _c 28 MIN	112500	75000	67500	45000
ALUM 2024-T351	60000	40000	36000	24000

Standard Groove Sizes

Bearing Size Bore Code	G Width
3 & 4	.062
5 - 10	.078
12 - 16	.094
20 & above	.109

Allowable Stress Metal-to-Metal Bearings (psi)

Race Material	Radial		Axial	
	Ultimate	Limit	Ultimate	Limit
17-4PH, R _c 32-36	150000	100000	125000	83000
4130 R _c 32-36	150000	100000	125000	83000
A286 (AMS 5737)	140000	93000	95000	63000
AMPCO® 15 Bronze	75000	50000	45000	30000

AMPCO® is a registered trademark of AMPCO Metal Inc.



ROD END BEARING LOAD RATING

Rod end bearing load ratings can be generated only after carefully determining the load restrictions that each element of the rod end bearing imposes on the entire unit. In order to generate a frame of reference, consider the rod end bearing as a clock face, with the shank pointing down to the 6 o'clock position. The limiting factors in rating a rod end bearing are as follows:

1. The double shear capability of the bolt passing through the ball bore.
2. The bearing capability, a function of race material or self-lubricating liner system.
3. The rod end eye or hoop tension stress in the 3 o'clock-9 o'clock position.
4. The shank stress area, as a function of male or female rod end configuration.
5. The stress in the transition area between the threaded shank transition diameter and the rod end eye or hoop.

Most rod ends will fail under tension loading in about the 4 o'clock-8 o'clock portion of the eye or hoop. The Net Tension Area (NTA) can be found as follows:

$$NTA = .008726 \times D^2 \times \sin^{-1} \left(\frac{T}{D} \right) + \frac{T}{2} \sqrt{D^2 - T^2} - B \times T$$

Solve the $\sin^{-1} \left(\frac{T}{D} \right)$ in units of degrees, not radians.

This simple rod end load rating formula does not take into consideration such variables as special body shapes, thin race sections, hardness variation, lubrication holes, grooves, and hoop tension, which could significantly affect the load rating. Contact NHBB Applications Engineering for assistance in determining the load rating for specially designed Rod Ends and Sphericals.

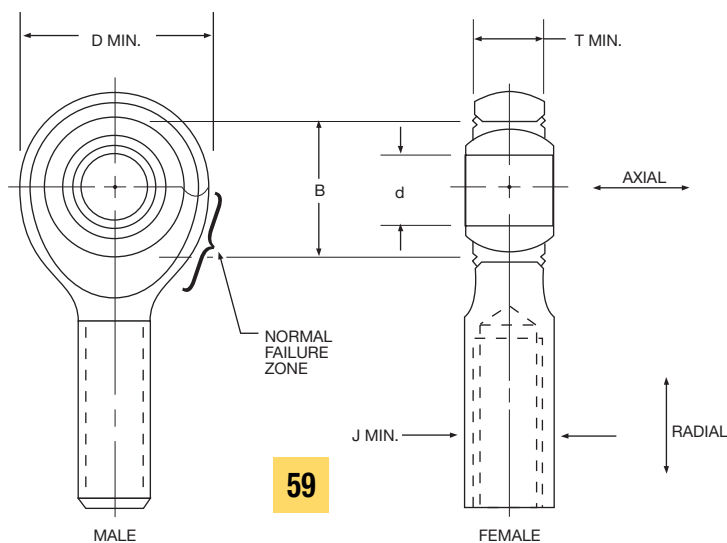

59

The shank stress area (SSA) is a function of being either male or female, as follows:

For the male:

$$SSA = (\text{minor thread diameter})^2 \frac{\pi}{4}$$

For the female:

$$SSA = [J^2 - (\text{major thread diameter})^2] \frac{\pi}{4}$$

Pin shear stress (PSS) for load "F" is as follows:

$$PSS = \frac{2F}{\pi d^2}$$

The axial load capability of a rod end is a function of the following:

1. The retention method used to mount the bearing in the rod end eye. See the Bearing Installation and Retention section for further information beginning on page 71.
2. The axial load capability of the bearing element.
3. The bending moment, if any, placed on the rod end.

Load Ratings and Misalignment Capabilities

PV Factor

While not a type of loading, the PV factor is very useful in comparing and predicting test results on high speed-low load applications such as helicopter conditions.

PV is the product of the stress (psi) and the velocity (fpm) applied to a bearing. Caution must be advised when considering extreme values of psi and fpm. The extreme must be considered individually, as well as together.

Because the PV factor is derived from the geometry and operating conditions of a bearing, it serves as a common denominator in comparing or predicting test results. For this reason PV values are included in the wear curves of 22 and 23 (page 61) in the Self-Lubricating TEFLON® Liner Systems section, page 60.

The formula for determining the PV value for a spherical bearing is as follows:

$$PV = (\infty) \text{ (cpm)} (D_B) \text{ (psi)} (.00073)$$

Where:

∞ = total angular travel in degrees per cycle
(ie. $\pm 25^\circ = 100^\circ$ total travel)

cpm = cycles per minute (oscillation rate)

D_B = ball diameter

psi = bearing stress

Dynamic Oscillating Radial Load

The dynamic oscillating radial load ratings given in this catalog for ADB, ADW, ADBY, ADB-N, ADW-N, ADBL and ADWL series self-lubricating spherical bearings are based on testing in accordance with AS81820. For conditions other than those specified by AS81820 contact NHBB Applications Engineering.

NHBB TESTING CAPABILITIES

Mechanical Test Equipment

NHBB has a variety of equipment to test spherical and rod end bearings under diverse conditions. NHBB performance data exceeds military and individual manufacturers' design requirements. Maximum capabilities of NHBB testing machines are shown in table 9.

Polymer Test Equipment

NHBB has the following thermal analysis (TA) equipment to support and control the quality of composites/polymers through analytical techniques that measure the physical and mechanical properties as a function of temperature and time:

1. Differential Scanning Calorimeter (DSC)
2. Thermogravimetric Analyzer (TGA)
3. Dynamic Mechanical Analyzer (DMA)
4. Thermomechanical Analyzer (TMA)
5. Thermo-Oxidative Stability Test (TOS)
6. Acid Digestion System
7. Fourier Transform Infrared Spectroscopy (FTIR)

TABLE 9: NHBB Testing Capabilities

	Force
Material Testing (Universal Testing Machine)	110,000 Lbs.
Static Compression/Tension	200,000 Lbs.
Low Speed Oscillation (up to 50 cpm)	
Uni-directional Loading	
(1 machine, 2 station) (700°F)	20,000 Lbs.
(1 machine, 2 station) (700°F)	70,000 Lbs.
Moderate To High Speed Oscillation	
Uni-directional Load (room temp.)	
(1 machine, 2 station) (1000 cpm)	1,000 Lbs.
(1 machine, 2 station) (1500 cpm)	1,000 Lbs.
(1 machine, 6 station) (200-600 cpm)	8,000 Lbs.
Low Speed Oscillation	
Reversing or Alternating Load (room temp.)	
(1 machine, 2 station) (up to 50 cpm)	40,000 Lbs.
High Speed, Oscillation	
Reversing and Alternating Load (room temp.)	
(2 machines, 1 station each) (400 cpm)	2,500 Lbs.
Airframe Track Roller	
Testing Machine (roller against flat plate)	60,000 Lbs.



FORMULA FOR DETERMINING MISALIGNMENT OF ROD END & SPHERICAL BEARINGS

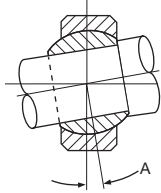

60 $A = \sin^{-1} \frac{W}{E} - \sin^{-1} \frac{T}{E}$

60 Standard Method

Most standard rod end and spherical bearing misalignment angles specified in NHBB catalogs are based on this method.

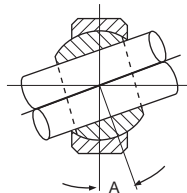

61 $A = \cos^{-1} \frac{B}{E} - \sin^{-1} \frac{T}{E}$

61 Design Reference

This method may be used as design reference for installation purposes, but should not be used as a functioning misalignment under load.

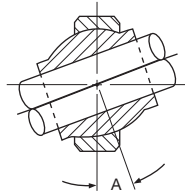

62 $A = \cos^{-1} \frac{S}{E} - \sin^{-1} \frac{T}{E}$

62 High Misalignment Series Method

(Neck balls only)

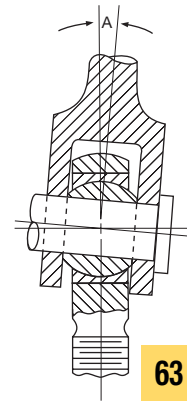

63 $A = \sin^{-1} \frac{W}{D} - \sin^{-1} \frac{T}{D}$

63 Rod End Clevis Misalignment

HOW NHBB SPECIFIES CATALOG BEARING AND ROD END MISALIGNMENT

The misalignment angle of a rod end or spherical bearing refers to the angle between the ball centerline and the outer member centerline when the ball is misaligned to the extreme position allowed by the clevis or shaft design, as applicable.

NOTE: Since angle "A" applies equally on both sides of the centerline, it follows that total misalignment of the bearing is double the value obtained for "A".

60 through 63 illustrate varying types of bearing misalignment and a formula for calculating each

Where:

A = angle of misalignment	B = bore of ball
D = head diameter (rod end)	E = ball spherical diameter
S = shoulder diameter (neck ball)	T = housing (race) width
W = width of ball	

64 illustrates how misalignment angles for standard ball spherical bearings and rod ends are represented in NHBB catalogs. The misalignment angle is calculated per 60 formula. Neck ball (high misalignment) bearings and rod ends are represented in the same manner, but are calculated per 62 formula.

NHBB prefers not to use rod end clevis misalignment for the following reason. The rod end clevis misalignment formula presupposes a clevis configuration as shown in 63 in which the clevis slot and ball faces are of equal width and in direct contact. In aircraft applications the configuration shown in 65 is

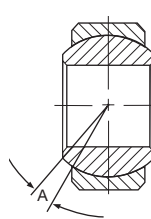

64

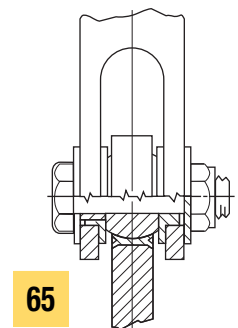
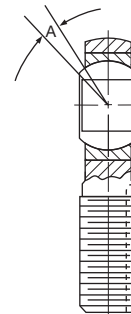

65

Typical Rod End/Clevis Installation

Bearing Selection Factors

ROLLING ELEMENT BEARINGS

1. Low load – high speed bearings should usually be antifriction rolling element bearings, except for lubricated sleeve bearings under very low load and constant rotation rather than oscillatory.

METAL-TO-METAL SPHERICALS AND ROD ENDS

1. These are recommended for most joints which are primarily static, need only periodic lubrication and require a minimum of permanent set under high loads.
2. They are also recommended for some moving applications such as landing gears, where most of the motion occurs under low loading, but where the bearing is nearly static under the high impact loads when the gear is locked.
3. Hardened 52100 or 440C balls with heat-treated outer races of either chrome-moly, alloy steel, or precipitation hardened stainless steel are recommended when loads are very high in relation to the available envelope.
4. Aluminum bronze races are less apt to seize or gall under vibratory conditions or if lubrication conditions are minimal, providing the required maximum load capacity is not too great (the load capacity is usually about 1/2 that of the heat treated steel race bearings). In general, materials containing an appreciable amount of copper are good bearing materials.
5. A beryllium-copper ball operating against a heat treated stainless steel race is an excellent combination for dynamic oscillating conditions under very high loads, providing adequate lubrication is present. This requires either an automatic lube system or frequent maintenance provisions.
6. Metal-to-metal spherical bearings and rod ends are often fitted with aluminum-nickel-bronze sleeves in the ball bore, with lubrication provisions, so that the relative motion and resulting wear take place between the shaft and the sleeve, with only misalignment taking place at the ball spherical surface. This allows replacement of the sleeves without replacement of the expensive portion of the bearing.
7. For extremely high load carrying capacity in a limited envelope, spherical bearings with both ball and swaged outer race made of heat-treated maraging steel of 300ksi tensile strength are sometimes used, and can be formed by a special processing procedure.
8. Special types of metal-to-metal sphericals such as loader slot bearings, fractured outer race bearings, or snap-assembled bearings (page 54 and 55) are used for some applications where very hard inner and outer races are desirable for wear and strength reasons, but require special geometry (a relatively narrow ball).
9. Spherical and rod end bearings for both high temperature and cryogenic applications are available using special materials such as the Inconels®, Stellite® and other cobalt alloys, A-286, Rene 41® and others. Special dry film lubricants or silverplating in the race I.D. are sometimes used in these bearings.
10. Two-piece swage-coined rod ends (page 56 **11**) should be used primarily for applications which require high load carrying capacity in a basically static condition with some misalignment capability, since the rod end body cross-sectional area available to carry tension is greater than with a 3-piece rod end, the insert outer race area having been replaced by body area. However, ball-to-race conformity is usually poor, hence rapid wear and/or fretting and galling can occur under dynamic or oscillating loading.
11. Two-piece Mohawk rod ends (page 56 **12**) for commercial use or non-critical applications are available. The Mohawk design has better ball-to-race conformity than the 2-piece swage-coined design and can be used in dynamic applications but only at relatively low loads.
12. Most metal-to-metal bearings are designed with a small radial clearance to facilitate assembly with the mating part and assure that the bearing does not bind up if assembled into its housing with an interference fit. However, they may be made with a preload, providing there is a fairly large tolerance on this preload, for applications where absolutely no play can be tolerated.

INCONEL® is a registered trademark of Inco Alloys International, Inc. and The International Nickel Company, Inc.

RENE 41® is a registered trademark of General Electric Company

STELLITE® is a registered trademark of DELORO STELLITE COMPANY, INC.



SELF-LUBRICATING TEFLON® TYPE LINED SLEEVES, SPHERICALS AND ROD END BEARINGS

1. These consist of a relatively thin composite liner containing TEFLON® (polytetrafluoroethylene) as a lubricant and bonded to a metallic backing material.
2. They are recommended for applications requiring considerable oscillation and misalignment under very heavy loads and where frequent lubrication is undesirable or impossible. To gain full life from these bearings, a wear of about .005 from the liner surface must be tolerable.
3. This type is especially suited for hydraulic actuators, many aircraft landing gear door applications, vibration damping devices, hinge and actuation link bearings for control surfaces, sliding guide bearings for flaps and leading edge slats, and power control system drive linkage bearings, along with many others not mentioned.

CHECK LIST OF FACTORS TO BE CONSIDERED BY THE APPLICATIONS ENGINEER IN SELECTION OR DESIGN OF SPHERICAL BEARINGS

1. Bearing envelope requirements and/or restrictions
2. Weight limitations
3. Whether used in a static or dynamic application
4. For sleeve bearings, whether the shaft is oscillating or rotating continuously in one direction or both directions
5. Loading:
 - (A) Maximum static radial or axial
 - (B) Maximum and normal dynamic
 - (C) Reversing or uni-directional
 - (D) Shock or vibratory conditions
6. Relative movement
 - (A) Angle of oscillation
 - (B) Velocity in terms of rpm or cycles per minute
 - (C) Required angle of misalignment
 - (D) Load-velocity phase relationship
7. Allowable wear
8. Life requirement, preferably in number of cycles
9. Operating temperature range
10. Preload or clearance requirements
11. Lubrication methods, accessibility, and frequency of maintenance available
12. Environmental conditions including exposure to dirt, moisture and other contaminants
13. Installation requirements, including staking methods, housing and shaft fits, etc.

For additional considerations, please consult NHBB Applications Engineering staff.

Specifications Compliance

NHBB complies with many government specifications in the manufacture of its products. The most common of these specifications are listed in table 10.

NHBB also complies with most of the major aerospace manufacturers specifications regarding procedures such as plating, testing, and heat treating.

TABLE 10: Specifications Compliance

Plating, Coating and Surface Treatment	
Alodine	* SAE AMS-C-5541
Anodize (Chromic)	SAE AMS-A-8625 Type I Class 1
Anodize (Sulphuric)	* SAE AMS-A-8625 Type II Class 1
Anodize (Hard)	* SAE AMS-A-8625 Type III Class 1
Cadmium	* SAE AMS-QQ-P-416 Type I Class 3 (Races)
Cadmium (Supplementary Chromate Treatment)	* SAE AMS-QQ-P-416 Type II Class 2 (Bodies)
Cadmium (Vacuum Deposited)	SAE AMS-C-8837
Chromium	* SAE AMS-QQ-C-320 Class 2 (.0002" to .0005" thickness)
Chromium	AMS 2406
Nickel (Electroless)	SAE AMS-C-26074
Nickel (Electrodeposited)	SAE AMS-QQ-N-290
Passivate	AMS QQ-P-35 or ASTM-A 967
Silver	AMS 2410
Zinc (Chromate Primer)	TT-P-1757
Heat Treatment	
Steel, Alloy and Stainless	SAE-AMS-H-6875
Aluminum	SAE-AMS-H-6088
Beryllium Copper	SAE-AMS-H-7199
Titanium	AS-H-81200
Non-Destructive Testing	
Fluorescent Penetrant	ASTM-E-1417
Magnetic Particle	ASTM-E-1444
Ultrasonic	SAE AMS STD 2154
Quality Control	
Quality Systems	ISO 9001
Aerospace Quality Systems	AS 9000
Sampling Procedures and Tables for Inspection by Attributes	ANSI/ASQE Z 1.4
Machining	
Threads, Rolled or Turned	AS 8879 and MIL-S-7742
Marking and Packaging	
Military Packaging	MIL-STD-129
Marking	MIL-STD-130
Preservation	MIL-DTL-197

*NHBB Standards



Inch/Metric Conversion Table

TABLE 11: Inch/Metric Conversion Table

Fraction	Inch Decimal	mm	Fraction	Inch Decimal	mm	Fraction	Inch Decimal	mm	Fraction	Inch Decimal	mm
	0.00004	0.001	17/64	0.2656	6.746		0.6693	17.		1.3780	35.
	0.00039	0.01		0.2756	7.	43/64	0.6719	17.066		1.4173	36.
	0.0010	0.025	9/32	0.2812	7.1437	11/16	0.6875	17.4625	1 1/2	1.5000	38.1
	0.0020	0.051	19/64	0.2969	7.5406	45/64	0.7031	17.859		1.5354	39.
	0.0030	0.0762	5/16	0.3125	7.9375		0.7086	18.		1.5748	40.
	0.00394	0.1		0.3150	8.	23/32	0.7187	18.256		1.6535	42.
	0.0050	0.1270	21/64	0.3281	8.334	47/64	0.7344	18.653	1 3/4	1.7500	44.45
	0.00984	0.25	11/32	0.3437	8.731		0.7480	19.		1.7717	45.
	0.0100	0.254		0.3543	9.	3/4	0.7500	19.05		1.8898	48.
1/64	0.0156	0.396	23/64	0.3594	9.1281	49/64	0.7656	19.446		1.9685	50.
1/32	0.0312	0.793	3/8	0.3750	9.525	25/32	0.7812	19.843	2	2.000	50.8
	0.03937	1.	25/64	0.3906	9.9219		0.7874	20.		2.0472	52.
3/64	0.0469	1.191		0.3937	10.	51/64	0.7969	20.240		2.1654	55.
	0.0591	1.5	13/32	0.4062	10.318	13/16	0.8125	20.6375		2.2047	56.
1/16	0.0625	1.5875	27/64	0.4219	10.716		0.8268	21.	2 1/4	2.2500	57.15
5/64	0.0781	1.984		0.4331	11.	53/64	0.8281	21.034		2.3622	60.
	0.0787	2.	7/16	0.4375	11.1125	27/32	0.8437	21.431	2 1/2	2.5000	63.5
3/32	0.0937	2.381	29/64	0.4531	11.509	55/64	0.8594	21.828		2.5197	64.
	0.0984	2.5	15/32	0.4687	11.906		0.8661	22.	2 3/4	2.7500	69.85
	0.1000	2.54		0.4724	12.	7/8	0.8750	22.225		2.8346	72.
7/64	0.1094	2.778	31/64	0.4844	12.303	57/64	0.8906	22.621		2.9528	75.
	0.1181	3.	1/2	0.5000	12.7		0.9055	23.	3	3.0000	76.2
1/8	0.1250	3.175		0.5118	13.	29/32	0.9062	23.018		3.1496	80.
	0.1378	3.5	33/64	0.5156	13.096	59/64	0.9219	23.416	3 1/4	3.2500	82.55
9/64	0.1406	3.571	17/32	0.5312	13.493	15/16	0.9375	23.8125	3 1/2	3.5000	88.9
5/32	0.1562	3.968	35/64	0.5469	13.891		0.9449	24.		3.5433	90.
	0.1575	4.		0.5512	14.	61/64	0.9531	24.209	3 3/4	3.7500	95.25
11/64	0.1719	4.366	9/16	0.5625	14.2875	31/32	0.9687	24.606		3.9370	100.
	0.1772	4.5	37/64	0.5781	14.684		0.9843	25.	4	4.0000	101.6
3/16	0.1875	4.7625		0.5906	15.	63/64	0.9844	25.003	4 1/4	4.2500	107.95
	0.1969	5.	19/32	0.5937	15.081	1	1.0000	25.4		4.3307	110.
13/64	0.2031	5.159	39/64	0.6094	15.478		1.0630	27.	4 1/2	4.5000	114.3
7/32	0.2187	5.556	5/8	0.6250	15.875		1.1024	28.		4.7244	120.
15/64	0.2344	5.953		0.6299	16.		1.1811	30.	4 3/4	4.7500	120.65
	0.2362	6.	41/64	0.6406	16.271	1 1/4	1.2500	31.75	5	5.0000	127.
1/4	0.2500	6.35	21/32	0.6562	16.668		1.2992	33.	5 1/2	5.5000	139.7

**TABLE 12:
Conversion Factors
for The U.S.
Customary System
(USCS) and
The International
System of Units (SI)**

	USCS to SI	SI to USCS
Length	1 in = 25.4 mm	1 mm = 0.0393701 in
Surface Texture	1 μ in = 0.0254 μm	1 μm = 39.3701 μ in
Area	1 in ² = 645.16 mm ²	1 mm ² = 0.00155 in ²
Volume	1 in ³ = 16.3871 cm ³	1 cm ³ = 0.0610237 in ³
Mass	1 lb = 0.45359 kg	1 kg = 2.20462 lb
	1 oz = 28.3495 g	1 g = 0.035274 oz
Density	1 lb/in ³ = 27.6799 g/cm ³	1 g/cm ³ = 0.036 lb/in ³
Force	1 lbf = 4.44822 N	1 N = 0.224809 lbf
Moment of Force (Torque)	1 lbf in = 0.112985 Nm	1 Nm = 8.85 lbf in
Stress	1 lbf/in ² = 0.00689 N/mm ²	1 N/mm ² = 145.038 lbf/in ²

Fahrenheit/Celsius Conversion Table

The numbers in center column refer to the temperatures either in Celsius or Fahrenheit which need conversion to the other scale. When converting from Fahrenheit to Celsius, the equivalent temperature will be found to the left of the center column. If converting from Celsius to Fahrenheit, the answer will be found to the right.

TABLE 13: Fahrenheit/Celsius Conversion Table

°C	°C/°F	°F
-79	-110	-166
-73	-100	-148
-68	-90	-130
-62	-80	-112
-57	-70	-94
-51	-60	-76
-45	-50	-58
-40	-40	-40
-34	-30	-22
-29	-20	-4
-23	-10	14
-17.7	0	32
-17.2	1	33.8
-16.6	2	35.6
-16.1	3	37.4
-15.5	4	39.2
-15.0	5	41.0
-14.4	6	42.8
-13.9	7	44.6
-13.3	8	46.4
-12.7	9	48.2
-12.2	10	50.0
-6.6	20	68.0
-1.1	30	86.0
4.4	40	104.0
9.9	50	122.0
15.6	60	140.0
21.0	70	158.0
26.8	80	176.0
32.1	90	194.0
37.7	100	212
43	110	230
49	120	248
54	130	266
60	140	284
65	150	302
71	160	320
76	170	338
83	180	356
88	190	374

°C	°C/°F	°F
93	200	392
99	210	410
104	220	428
110	230	446
115	240	464
121	250	482
127	260	500
132	270	518
138	280	536
143	290	554
149	300	572
154	310	590
160	320	608
165	330	626
171	340	644
177	350	662
182	360	680
188	370	698
193	380	716
199	390	734
204	400	752
210	410	770
215	420	788
221	430	806
226	440	824
232	450	842
238	460	860
243	470	878
249	480	896
254	490	914
260	500	932
265	510	950
271	520	968
276	530	986
282	540	1004
288	550	1022
293	560	1040
299	570	1058
304	580	1076
310	590	1094

°C	°C/°F	°F
315	600	1112
321	610	1130
326	620	1148
332	630	1166
338	640	1184
343	650	1202
349	660	1220
354	670	1238
360	680	1256
365	690	1274
371	700	1292
376	710	1310
382	720	1328
387	730	1346
393	740	1364
565	1050	1922
571	1060	1940
576	1070	1958
582	1080	1976
587	1090	1994
593	1100	2012
598	1110	2030
604	1120	2048
609	1130	2066
615	1140	2084
620	1150	2102
626	1160	2120
631	1170	2138
637	1180	2156
642	1190	2174
648	1200	2192
653	1210	2210
659	1220	2228
664	1230	2246
670	1240	2264
675	1250	2282
681	1260	2300
686	1270	2318
692	1280	2336
697	1290	2354

CAPABILITIES

Product Quality is Our First Priority



WE MEET EVERY STANDARD IN THE BOOK

We employ over 1,000 people in a total of 455,000 sq. ft. of manufacturing, engineering and administrative facilities. With a dedicated R&D staff, materials and testing laboratories, state-of-the-art manufacturing, and continuous quality programming, we maintain stringent controls over each step in the manufacturing process. This enables us to meet every major standard, including:

- ABEC
- MIL-SPEC
- AS 9000
- RBEC
- ISO 9000
- DI-9000 Rev. A





Ongoing New Product Development



HITECH DIVISION

Cylindrical Roller Bearings

WE CAN MAKE JUST ABOUT ANY BEARING

While NHBB's three divisions offer a wide range of standard bearings, our specialty is custom bearing design and manufacture. We also have the facilities to develop and incorporate special materials and lubricants in order to meet the requirements of leading-edge applications. We encourage you to consult with NHBB engineers as early as possible in the product design phase. We'll acquaint you with the most up-to-date developments in bearing technology and their impact on your applications.



ASTRO DIVISION

Racing Series Bearings



ASTRO DIVISION

Rod Ends, Sphericals and Link Assemblies

CAPABILITIES

Ongoing New Product Development



HITECH DIVISION

Ultra Precision Machine
Tool Bearings



PRECISION DIVISION

Miniature and Instrument

OUR FACILITIES INCLUDE:

- CAD CAM-based Manufacturing and Design
- Metallurgy and Testing Laboratories
- Class 10,000 Clean Room
- Class 100 Clean Workstations
- World Class Manufacturing
- Comprehensive Life Testing



ASTRO DIVISION

Composite Components