

NSK Linear Guides

Interchangeable Series for Industrial Automation Equipment

Ball slides and rails are sold separately for maximum convenience and flexibility. A standard stock ensures short delivery time.

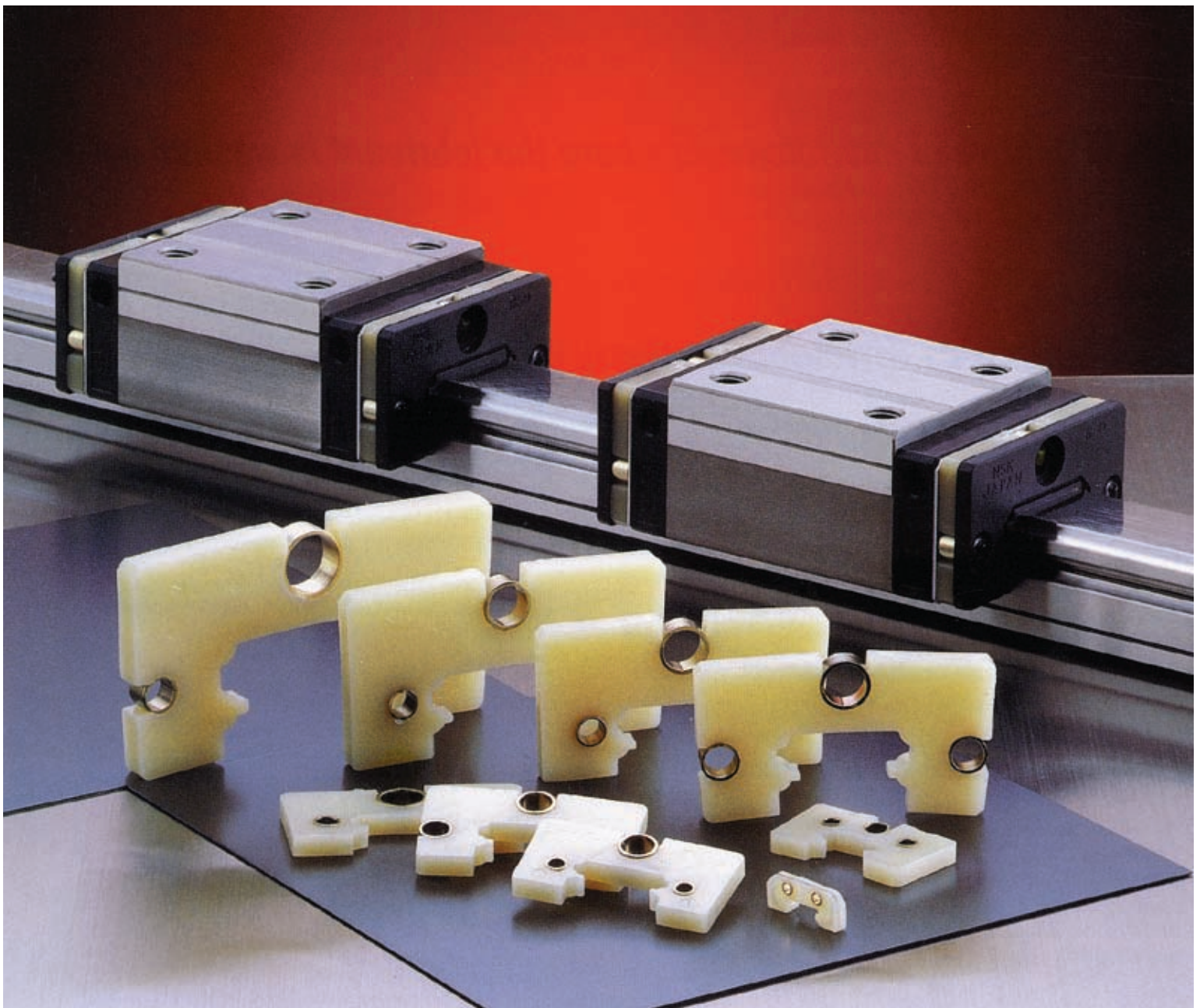

- **Five Types Available in Commercial Grade**
- **LE Series Miniature - Wide Type**
- **LH Series for High Load Capacity Applications**
- **LS Series for Compact Low Profile Space Saving Conditions**
- **LU Series Miniature Type**
- **LW Series Wide Type**
- **Interchangeable Rails and Ball Slides**
- **Preload and Clearance Types Available**
- **Fluoride Black Chrome Plated Rails and Ball Slides**
- **Large Inventory for Prompt Delivery**

CONTENTS

	PAGE
How to Use This Guide	3
Features	3
Interchange	4
Identification Numbers – ‘LH’ Series	6
Accuracy Standard – ‘LH’ Series Load Rating and Life Calculation	7
Dimensional Tables – ‘LH’ Ball Slides	8
Dimensional Tables – ‘LH’ Series Rails	12
Accessories – ‘LH’ Series	13
Identification Numbers – ‘LS’ Series	14
Accuracy Standard – ‘LS’ Series Load Rating and Life Calculation	15
Dimensional Tables – ‘LS’ Series Ball Slides	16
Dimensional Tables – ‘LS’ Series Rails	20
Accessories – ‘LS’ Series	21
Identification Numbers – ‘LU’ Series	22
Identification Numbers – ‘LE’ Series	23
Identification Numbers – ‘LW’ Series	24
Assembly and Mounting Method	25
Lubrication & Grease Fittings	26
Grease Units	27
Application Sheet – Rail Butting	31
K1™ Maintenance-Free Lubrication Units	32
Identification Numbers – K1™ Maintenance-Free Lubrication Units	33
K1™ Lubrication Units Handling and Assembly Instructions	34
Unit Conversion Chart	35

CAD DRAWING DATA

For LE/LH/LS/LU & LW-Series go to NSK technical website www.npa.nsk.com

For 3D IGES files on CD-ROM of LH/LS-Series Linear Guides email info@npa.nsk.com

Note: CAD DXF drawing files are also available for other linear motion products. Contact NSK.

How to Use this Guide

Use this guide to select the linear guide ball slides, rails and accessories that you need for your application. Pages 6, 14, 22, 23, 24 and 33 provide identification numbers that you will need to order the components for your application.

If you have any uncertainties, or would like more detailed information about any aspect of linear guides, please contact your NSK representative at one of our locations listed on the back cover.

FEATURES

Interchangeability of Rail and Ball Slide

One important manufacturing feature of the Gothic Arch is the ability to make highly accurate measurements on both the ball slide and rail, allowing for tight tolerance control, resulting in interchangeability. This means that additions and/or replacement of ball slides is easily done.

High Load Capacity and Long Life

NSK has developed an infinite ball recirculating type linear guide with the largest load capacity available (comparing equal size ball slides). This high load capability helps to ensure long life.

Compact Low Profile Type

To minimize space, NSK has developed low profile linear guides to handle various applications.

Miniature and Miniature Wide Type Stainless Steel

If light loads and corrosive conditions are present for your application needs, NSK can supply a miniature and miniature wide type linear guide in stainless steel. NSK's built-in ball retainer system allows for easy installation and removal of ball slides.

Wide Type

If your application requires low profile combined with high load, NSK offers the wide series linear guides.

Shock Resistant Design

Another design feature of the Gothic arch is its ability to absorb vertical shock loads from above using four-row groove configuration. This design is favorable in case of unexpected accidents during installation, or the operation of equipment. The ball groove is designed to avoid edge loading under extreme loads, extending the life of the unit.

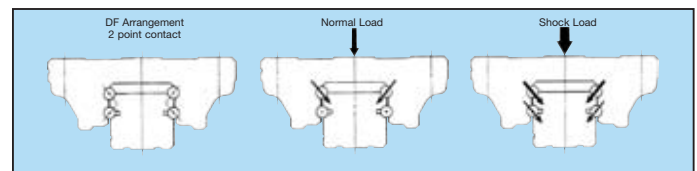

Normal load is carried on the top two grooves.
Shock load is carried by all four grooves.

Universal Slider

NSK has incorporated both thru and tapped holes into one flanged slider for a combination of mounting applications. (EM/EMZ replaces EL/ELZ and FL/FLZ • GM/GMZ replaces HL/HLZ and GL/GLZ)

Ability to Butt Rails

Tolerance of ball grooves on the ball slides and rails are controlled to allow for butting, giving you the flexibility of unlimited lengths. We can offer a stocked linear guide rail with versatility in assembling preloaded or clearance type ball slides.

K1™ Maintenance-Free Lubrication Units

NSK has the K1™ Lubrication Units for all five series of interchangeable linear guides. These K1™ Lubrication Units are all available from stock.

Maximum Rail Length in One Section Available up to 4,000 mm.

Short Delivery Time

We can ship from our large inventory, both standard and custom cut-to-length linear rails.

Fluoride Low Temperature Chrome Plating

NSK has a plating for linear bearings and rails to cover conditions requiring wet, corrosive and clean room applications. NSK also uses industry approved armaloy coating. These are available from stock.

Interchange – Linear Guide (LH & LS Series)

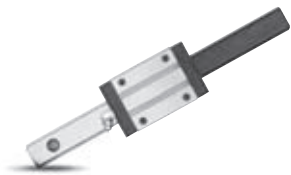

Linear Guides are designed for high precision motion and control applications. They provide greater rigidity and higher load capacity than shaft and bushing designs.

Some of the industries served - machine tool, robotics, medical and aerospace – require smooth travel and high accuracy.

DESCRIPTION	INTERCHANGE		
	NSK	THK	THOMSON
CARRIAGE PART NUMBER	LAH 20 AN Z 1 2 3 7	HSR 20 R 1 2 3	CG 20 CE 1 2 3
RAIL PART NUMBER	L1H 20 XXXX 1 2 4	HSR 20+ XXXXL 1 2 4	RG 20 N LXXXX 1 2 4
ASSEMBLY PART NUMBER	LH 20 XXXX AN 2 PC Z 1 2 4 3 5 6 7	HSR 20 R 2 SS C1 +XXXXL P 1 2 3 5 8 7 4 6	

The competitive manufacturers are provided for a convenient source of unit substitution. They can be considered interchangeable in most instances, but for special applications, please consult NSK Engineering. NSK assumes no liability with respect to errors or omissions.

NSK	1-Linear Guide Series	
	THK	THOMSON
LH LS	HSR SR	CG
NSK	2-Linear Guide Size	
	THK	THOMSON
LH15 LH20 LH25 LH30 LH35 LH45 LH55 LH65 LS15 LS20 LS25 LS30 LS35	HSR15 HSR20 HSR25 HSR30 HSR35 HSR45 HSR55 HSR65 SR15 SR20 SR25 SR30 SR35	CG20 CG25 CG30 CG35 CG45 CG55
NSK	3-Linear Guide Carriage Styles LH Series	
	THK	THOMSON
LAH##AN LAH##BN LAH##EM LAH##GM	HSR##TR/TRX/CR/R HSR##HTR/HR/LR HSR##TA/CA/A HSR##TB/CB/B HSR##HTA/HA/LA HTB/HB/LB	CG##CE CG##DE CGAA CG##BA
*THOMSON NOT DIMENSIONALLY EQUIVALENT, MAY NEED SHIM		
NSK	LS Series	
	THK	THOMSON
LAS##FL LAS##AL LAS##KL LAS##CL	SR##TB/TBY SR##TX/W/WY SR##SB/SBY SR##SX/V/VY	
INTERCHANGE = LAH or LAS FOLLOWED BY SERIES# + CARRIAGE STYLE		

NSK	4-Linear Guide Rail Length mm	
	THK	THOMSON
L1H##XXXX L1S##XXXX	HSR##+XXXXL HSR##+XXXXL	RG##NLXXXX
	5-Carriages Per Rail Number following carriage style = number of carriages per rail	
NSK	6-Accuracy Class	
	THK	THOMSON
PC P6 P5 P4 P3	H P SP UP	N H P S U
NSK	7-Preload (assemblies only)	
	THK	THOMSON
T Z 2 3 4	C1 C1 C0 C0	A B B C C
NSK	7-Preload (interchangeable car-	
	THK	THOMSON
Z	C1	B
NSK	8-Seals	
	THK	THOMSON
Standard with side and bottom seals. Double seals and protectors available.	SS-end/bottom UU-end ZZ-end/bottom/protector DD-double/bottom KK-double/bottom/protector	LDS ZZ DD KK

Interchange – Linear Guide (LU, LE & LW Series)

DESCRIPTION	INTERCHANGE														
	NSK				THK				THOMSON						
CARRIAGE PART NUMBER	LAU	15	AL		RSR	15	M		CD	15	AA				
	LAE	12	AR		RSR	12	W		1	2	3				
	LAW	17	EL		HRW	17	CA								
	1	2	3		1	2	3		1	2	3				
RAIL PART NUMBER	L1U	15	XXXX		RSR	15	+XXXXL		RD	15	LXXXX				
	L1E	12	XXXX		RSR	12W	+XXXXL								
	L1W	17	XXXX		HRW	17	+XXXXL								
	1	2	4		1	2	4		1	2	4				
ASSEMBLY PART NUMBER	LU	15	XXXX	AL	2	PC	ZT	2	RSR	15	R	UU	C1	+XXXXL	P
	LE	12	XXXX	AR	2	PC	ZT	2	RSR	12	W	UU	C1	+XXXXL	P
	1	2	4	3	5	6	7	5	1	2	3	8	7	4	6
	LW	17	XXXX	EL	2	PC	ZT	HRW	17	CA	2	UU	C1	+XXXXL	P
	1	2	4	3	5	6	7	1	2	3	5	8	7	4	6

The competitive manufacturers are provided for a convenient source of unit substitution. They can be considered interchangeable in most instances, but for special applications, please consult NSK Engineering. NSK assumes no liability with respect to errors or omissions.

NSK	1-Linear Guide Series	
	THK	THOMSON
LU LE LW	RSR RSR W HRW	CD
NSK	2-Linear Guide Size	
	THK	THOMSON
LU05 LU07 LU09 LU12 LU15 LE09 LE12 LE15 LW17 LW21 LW27 LW35 LW50	RSR07 RSR09 RSR12 RSR15 RSR09W RSR12W RSR15W HRW17 HRW21 HRW27 HRW35 HRW50	CD10 CD15 CD20
NSK	3-Linear Guide Carriage Styles LU & LE Series	
	THK	THOMSON
LAU/LAE##AR, AL LAU/LAE##TR, TL LAU/LAE##BL, UL LAU/LAE##CL, SL	RSR/RSRW##M,KM,WM,WVM RSR/RSRW##VM,M,KM RSR/RSRW##WN,N	CD##AA
NSK	LS Series	
	THK	THOMSON
LAW##EL	HRW##CA	
INTERCHANGE = LAU, LAE, LAW FOLLOWED BY SERIES # + CARRIAGE STYLE		

NSK	4-Linear Guide Rail Length mm	
	THK	THOMSON
L1U ## XXXX L1E ## XXXX L1W ## XXXX	RSR##+XXXXL RSR##W+XXXXL HRW##+XXXXL	RD##LXXXX
	5-Carriages Per Rail Number following carriage style = number of carriages per rail	
NSK	6-Accuracy Class	
	THK	THOMSON
PC P6 P5 P4 P3	H P SP UP	N H P S U
NSK	7-Preload (assemblies only)	
	THK	THOMSON
T Z 2 3 4	C1 C1 C0 C0	A B B C C
NSK	7-Preload (interchangeable car-	
	THK	THOMSON
Z	C1	B
NSK	8-Seals	
	THK	THOMSON
Standard with side and bottom seals. Double seals and protectors available.	SS-end/bottom UU-end ZZ-end/bottom/protector DD-double/bottom KK-double/bottom/protector	LDS ZZ DD KK

LH Series

Identification Number Ball Slide

Ball Slide (Stocked item)

LAH 25 AN Z - K

Ball Slide Type

Size No.

- AN: Square - Standard
- AL: Square - Short height standard
- BN: Square - Long
- BL: Square - Short height long
- EM: Flanged (Tapped & Thru hole) Standard
- GM: Flanged (Tapped & Thru hole) Long

Style

Material Code

- No Code: Standard Carbon Steel (May also be C)
- S: Stainless Steel (Standard for LU and LE Series)
- D: Carbon Steel + Fluoride Coating
- H: Stainless Steel + Fluoride Coating
- A: Carbon Steel + Armoloy Coating
- B: Stainless Steel + Armoloy Coating

- No Code: No special accessories and fluoride black chrome plating
- K: One K1™ Lubrication Unit each side
- K2: Two K1™ Lubrication Units each side
- D: Double Seals each side
- P: Protector Plate each side

- No Code: Clearance Type
- Z: Preloaded Type

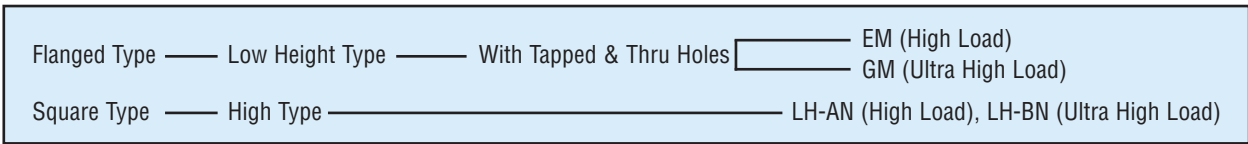

Fig.-1 LH-AN, LH-BN TYPE

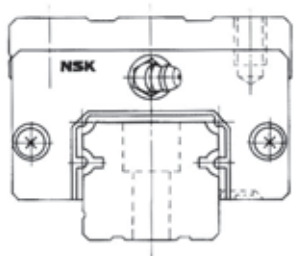
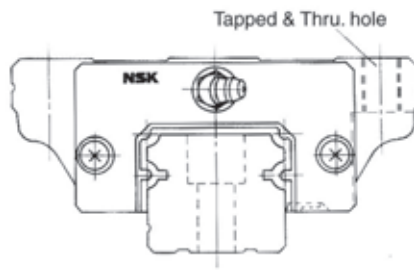

Fig.-2 LH-EM, LH-GM TYPE



Internal Clearance and Preload

The internal clearance refers to the amount of movement of the ball slide, when moved up and down with the rail fixed. The amount of preload is specified by size as follows.

Table 1

Unit: μm

Size	#15	#20 #25	#30 #35 #45	#55 #65
Clearance	15~-4	15~-5		
Preloaded	0~-4	0~-5	0~-7	0~-9

Accuracy Standard

The accuracy standard of the NSK “High Load Capacity LH-Series” is shown in Table 1. With high-accuracy control of individual rail size and interchangeability, the accuracy of Table 1 can be maintained sufficiently even after addition or replacement of the ball slide.

Table 1 Tolerances Unit : μm
(For Clearance Preload Type)

Tolerances (See Fig. 4 for Symbols)	Model No. LH	
	15, 20, 25, 30, 35	45, 55, 65
Mounting Height H	± 20	± 30
Variation of Mounting Height H	15 ⁽¹⁾ 30 ⁽²⁾	20 ⁽¹⁾ 35 ⁽²⁾
Mounting Width W_2 or W_2	± 30	± 30
Variation of Mounting Width W_2 or W_2	± 25	± 30
Running Parallelism of Face C to Face A Running Parallelism of Face D to Face B	Refer to Fig. 3	

W_2 is applicable to the reference side only. Note: during installation the reference side is indicated by a line provided on the side of ball slide and rail. (See Fig. 4)

1. Variation on the same rail.
2. Variation on multiple rails.

Fig.-3 Running Parallelism

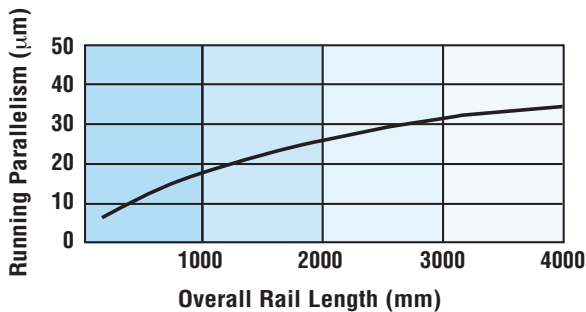
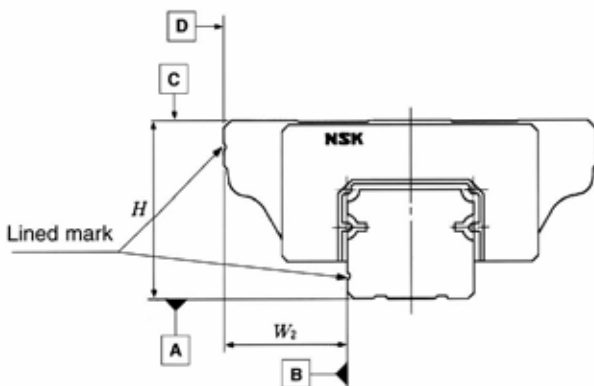

Fig.-4 Accuracy Standard



Load Rating and Life

The LH-Series is based on a design applying load from above. Therefore the dimension table shows the basic dynamic load rating C and basic static load rating C_0 for the downward direction. If the load is applied laterally or upward refer to values in Table 2.

Table 2 Basic Load Rating Correction for Direction

Load Direction	Basic Dynamic Load Rating	Basic Static Load Rating
Downward	C	C_0
Upward	C	$0.75C_0$
Laterally	$0.88C$	$0.63C_0$

Estimate the life of linear guides using the equation below.

Fig.-5

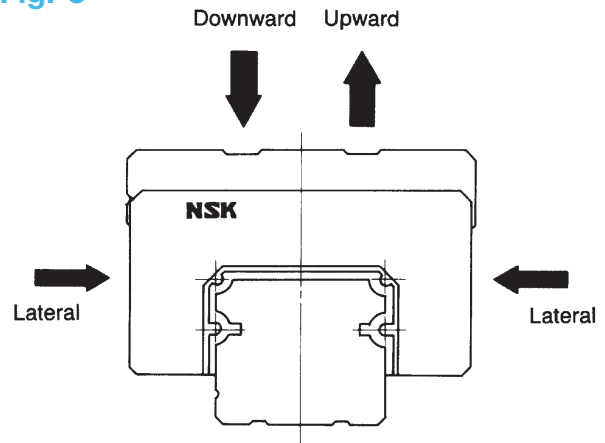

$$L = 50 \left(\frac{C}{f_w \cdot F} \right)^3$$

where,

- L : Rated fatigue life (km)
- C : Basic dynamic load rating (N)
- F : Load to a ball slide (N)
(Dynamic equivalent load)
- f_w : Load factor
 - $f_w = 1.0 \sim 1.2$ (Smooth condition)
 - $f_w = 1.2 \sim 1.5$ (Normal condition)
 - $f_w = 1.5 \sim 3.0$ (With shock or vibration)

LH Series

Ball Slide Dimension Table

Square Type

LAH-AN/ANZ

-AL/ALZ

LAH-BN/BNZ

-BL/BLZ

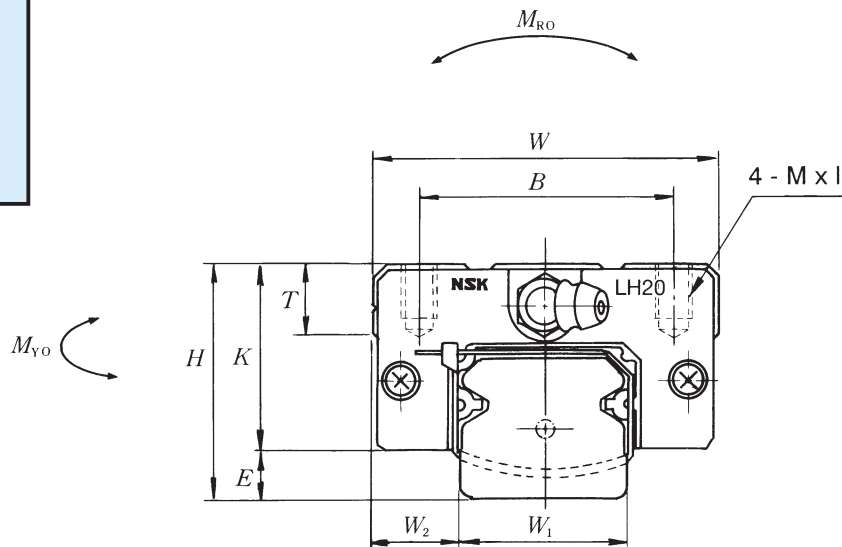

Model No.	Ass'y Dimensions			Ball Slide Dimensions								
	H	E	W ₂	W	B	L	L ₁	J	J ₁	K	T	M x pitch x l
LAH15 AN/ANZ LAH15 BN/BNZ	28	4.6	9.5	34	26	55	39	26	6.5	23.4	8	M4 x 0.7 x 6
LAH20 AN/ANZ LAH20 BN/BNZ	30	5	12	44	32	69.8 91.8	50 72	36 50	7 11	25	12	M5 x 0.8 x 6
LAH25 AL/ALZ LAH25 AN/ANZ LAH25 BL/BLZ LAH25 BN/BNZ	36 40 36 40	7	12.5	48	35	79 107	58 86	35 50	11.5 18	33	12	M6 x 1 x 6 M6 x 1 x 9 M6 x 1 x 6 M6 x 1 x 9
LAH30 AL/ALZ LAH30 AN/ANZ LAH30 BL/BLZ LAH30 BN/BNZ	42 45 42 45	9	16	60	40	85.6 124.6	59 98	40 60	9.5 19	36	14	M8 x 1.25 x 8 M8 x 1.25 x 10 M8 x 1.25 x 8 M8 x 1.25 x 10
LAH35 AL/ALZ LAH35 AN/ANZ LAH35 BL/BLZ LAH35 BN/BNZ	48 55 48 55	9.5	18	70	50	109 143	80 114	50 72	15 21	45.5	15	M8 x 1.25 x 8 M8 x 1.25 x 12 M8 x 1.25 x 8 M8 x 1.25 x 8
LAH45 AN/ANZ LAH45 BN/BNZ	70	14	20.5	86	60	139 171	105 137	60 80	22.5 28.5	56	17	M10 x 1.5 x 17
LAH55 AN/ANZ LAH55 BN/BNZ	80	15	23.5	100	75	163 201	126 164	75 95	25.5 34.5	65	18	M12 x 1.75 x 18
LAH65 AN/ANZ LAH65 BN/BNZ	90	16	31.5	126	76	193 253	147 207	70 120	38.5 48.5	74	23	M16 x 2 x 20

Note: W, rail dimensions are on Page 12.

Refer to
pages 32 to 34 regarding
technical information for
the K1™ Maintenance-Free
Lubrication Unit

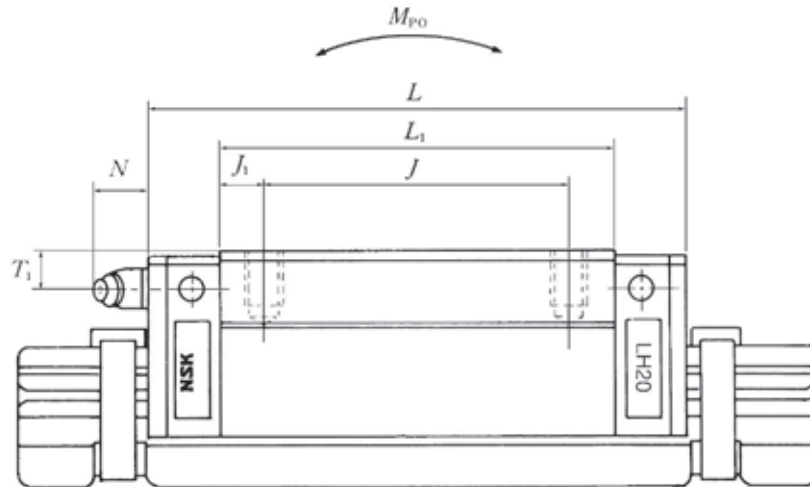

Unit : mm

Grease Fitting			Basic Load Ratings					Weight (kg)	Model No.
Mounting Hole Thread Spec.	T_1	N	Dynamic C (N)	Static C_0 (N)	Static Moment (N•m)				
					M_{RD}	M_{PO}	M_{YO}		
ø3 (thru hole)	8.5	3.3	10800	20700	108	95	80	0.18	LAH15 AN/ANZ LAH15 BN/BNZ
			14600	32000	166	216	181	0.33	
M6 x 0.75	5	11	17400	32500	219	185	155	0.48	LAH20 AN/ANZ LAH20 BN/BNZ
			23500	50500	340	420	355	0.55	
M6 x 0.75	10	11	25600	46000	360	320	267	0.55	LAH25 AL/ALZ LAH25 AN/ANZ LAH25 BL/BLZ LAH25 BN/BNZ
			34500	71000	555	725	610	0.82	
M6 x 0.75	10	11	31000	51500	490	350	292	0.77	LAH30 AL/ALZ LAH30 AN/ANZ LAH30 BL/BLZ LAH30 BN/BNZ
			46000	91500	870	1030	865	1.3	
M6 x 0.75	15	11	47500	80500	950	755	630	1.5	LAH35 AL/ALZ LAH35 AN/ANZ LAH35 BL/BLZ LAH35 BN/BNZ
			61500	117000	1380	1530	1280	2.1	
PT1/8	20	13	81000 99000	140000 187000	2140 2860	1740 3000	1460 2520	3 3.9	LAH45 AN/ANZ LAH45 BN/BNZ
PT1/8	21	13	119000 146000	198000 264000	3600 4850	3000 5150	2510 4350	4.7 6.1	LAH55 AN/ANZ LAH55 BN/BNZ
PT1/8	19	13	181000 235000	281000 410000	6150 8950	4950 8950	4150 8450	7.7 10.8	LAH65 AN/ANZ LAH65 BN/BNZ

LH Series

Ball Slide Dimension Table

Flange Type

LAH-EM/EMZ
(formerly EL-ELZ-90)
LAH-GM/GMZ
(formerly GL-GLZ-90)

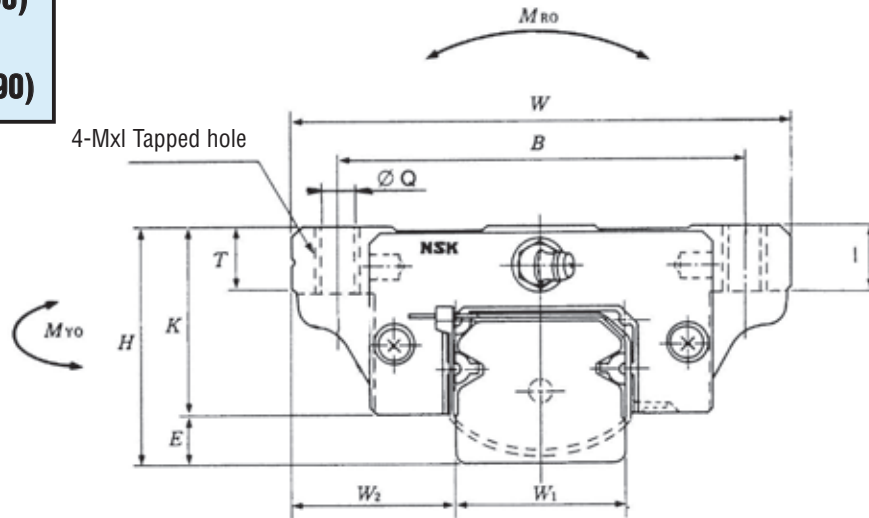

Note: EM/EMZ and GM/GMZ is a combination of Tapped hole and Thru hole.

Model No.	Ass'y Dimensions			Ball Slide Dimensions									
	H	E	W ₂	W	B x J	L	L ₁	J ₁	K	T	M x pitch x l	Ø Q x l	Bolt Size Through Hole Q
LAH15 EM/EMZ GM/GMZ	24	4.6	16	47	38 x 30	55 74	39 58	4.5 14	19.4	8	M5 x 0.8 x 7	Ø4.4 x 8	M4
LAH20 EM/EMZ GM/GMZ	30	5	21.5	63	53 x 40	69.8 91.8	50 72	5 16	25	10	M6 x 1 x 9.5	Ø5.3 x 10	M5
LAH25 EM/EMZ GM/GMZ	36	7	23.5	70	57 x 45	79 107	58 86	6.5 20.5	29	11	M8 x 1.25 x 10	Ø6.8 x 10	M6
LAH30 EM/EMZ GM/GMZ	42	9	31	90	72 x 52	98.6 124.6	72 98	10 23	33	11	M10 x 1.5 x 12	Ø8.6 x 12	M8
LAH35 EM/EMZ GM/GMZ	48	9.5	33	100	82 x 62	109 143	80 114	9 26	38.5	12	M10 x 1.5 x 13	Ø8.6 x 13	M8
LAH45 EM/EMZ GM/GMZ	60	14	37.5	120	100 x 80	139 171	105 137	12.5 28.5	46	13	M12 x 1.75 x 15	Ø10.5 x 15	M10
LAH55 EM/EMZ GM/GMZ	70	15	43.5	140	116 x 95	163 201	126 164	15.5 34.5	55	15	M14 x 2 x 18	Ø12.5 x 18	M12
LAH65 EM/EMZ GM/GMZ	90	16	53.5	170	142 x 110	193 253	147 207	18.5 48.5	74	23	M16 x 2 x 24	Ø14.6 x 24	M14

Note: W, rail dimensions are on Page 12.

(EM/EMZ replaces EL/ELZ and FL/FLZ • GM/GMZ replaces HL/HLZ and GL/GLZ)

Refer to
pages 32 to 34 regarding
technical information for
the K1™ Maintenance-Free
Lubrication Unit

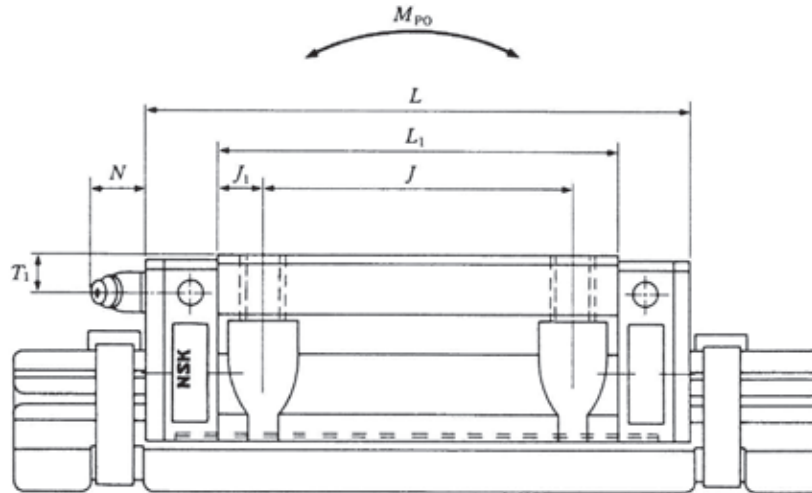

Unit : mm

Grease Fitting			Basic Load Ratings					Weight (kg)	Model No.
Mounting Hole Thread Spec.	T_1	N	Dynamic C (N)	Static C_0 (N)	Static Moment (N•m)				
					M_{RO}	M_{PO}	M_{YO}		
Ø3 (thru hole)	4.5	3.3	10800 14600	20700 32000	108 166	95 216	80 181	0.17 0.25	LAH15 EM/EMZ GM/GMZ
M6 x 0.75	5	11	17400 23500	32500 50500	219 340	185 420	155 355	0.45 0.65	LAH20 EM/EMZ GM/GMZ
M6 x 0.75	6	11	25600 34500	46000 71000	360 555	320 725	267 610	0.63 0.93	LAH25 EM/EMZ GM/GMZ
M6 x 0.75	7	11	35500 46000	63000 91500	600 870	350 1030	292 865	1.2 1.6	LAH30 EM/EMZ GM/GMZ
M6 x 0.75	8	11.5	47500 61500	80500 117000	950 1380	755 1530	630 1280	1.7 2.4	LAH35 EM/EMZ GM/GMZ
PT1/8	10	13	81000 99000	140000 187000	2140 2860	1740 3000	1460 2520	3 3.9	LAH45 EM/EMZ GM/GMZ
PT1/8	11	13	119000 146000	198000 264000	3600 4850	3000 5150	2510 4350	5 6.5	LAH55 EM/EMZ GM/GMZ
PT1/8	19	13	181000 235000	281000 410000	6150 8950	4950 10100	4150 8450	10 14.1	LAH65 EM/EMZ GM/GMZ

LH Series

Rail Dimension Table

Separately Sold Rail for NSK Linear Guide

LH Series Standard Rail

L1H-Z : Preloaded Interchangeable Type

LH Series Butting Rail

L1H-01Z : Preloaded Interchangeable Type

LH Series butting rail features higher precision tolerances for L_0 and G dimensions.

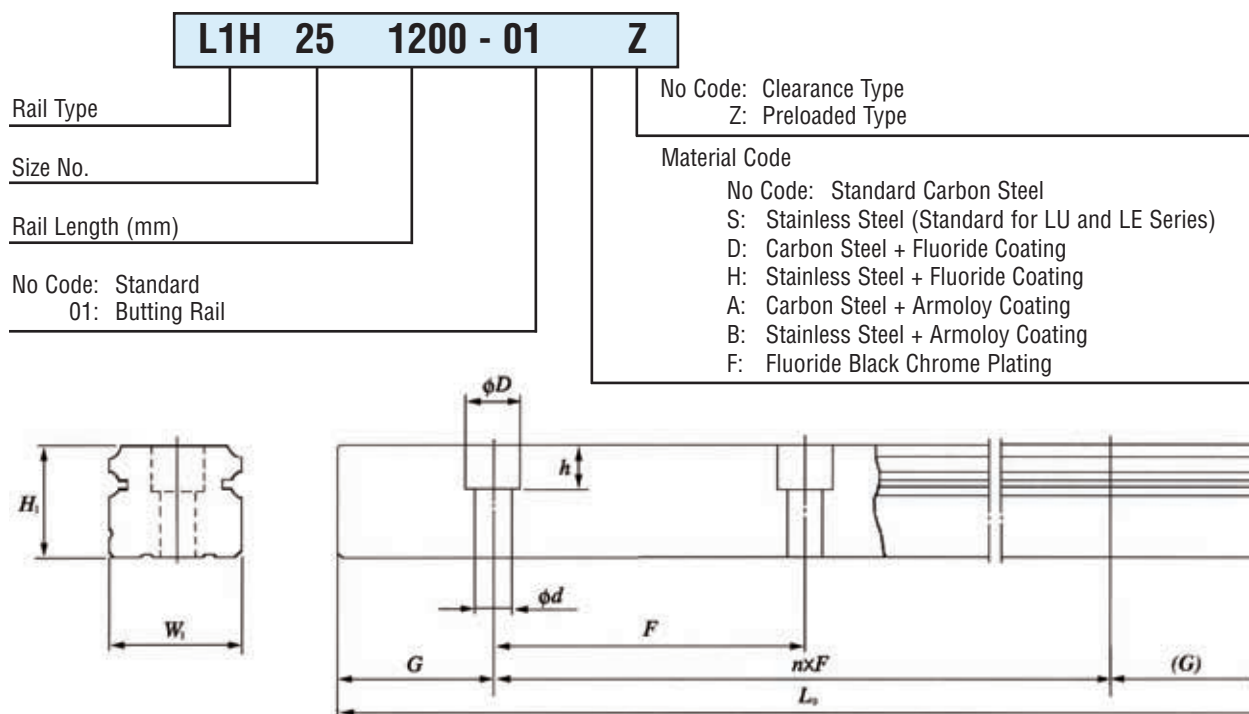

Rail Dimensions Table

Unit: mm

1 mm = .0394 inch
1kgf/m = .67 Ft/Lb

Model No.		Max. rail length L_0 max. () indicates Stainless Steel	W_1	H_1	F	$d \times D \times h$	Rail	
Standard	Butting						Butting	$G_{0.05}$
L1H15	L1H15-01	1440	15	15	60	4.5 x 7.5 x 5.3	30	1.6
L1H15-Z	L1H15-01Z	(1260)						
L1H20	L1H20-01	3960	20	18	60	6 x 9.5 x 8.5	30	2.6
L1H20-Z	L1H20-01Z	(3460)						
L1H25	L1H25-01	3960	23	22	60	7 x 11 x 9	30	3.6
L1H25-Z	L1H25-01Z	(3460)						
L1H30	L1H30-01	4000	28	26	80	9 x 14 x 12	40	5.2
L1H30-Z	L1H30-01Z	(3480)						
L1H35	L1H35-01	4000	34	29	80	9 x 14 x 12	40	7.2
L1H35-Z	L1H35-01Z							
L1H45	L1H45-01	3990	45	38	105	14 x 20 x 17	52.5	12.3
L1H45-Z	L1H45-01Z							
L1H55	L1H55-01	3960	53	44	120	16 x 23 x 20	60	16.9
L1H55-Z	L1H55-01Z							
L1H65	L1H65-01	3900	63	53	150	18 x 26 x 22	75	24.3
L1H65-Z	L1H65-01Z							

LH Series Accessories

Protector and Double Seal

Travel length is reduced by the thickness of the end seal on the ball slide. Consider the value of V in the table below when calculating the travel length.

Protector Seal			Unit : mm
Linear Guide Model No.	Protector No. Plug End	Protector No. Grease Fitting End	Increased Thickness V1
LH15	LH15PT-01	LH15PTC-01	2.7
LH20	LH20PT-01	LH20PTC-01	2.9
LH25	LH25PT-01	LH25PTC-01	3.2
LH30	LH30PT-01	LH30PTC-01	4.2
LH35	LH35PT-01	LH35PTC-01	4.2
LH45	LH45PT-01	LH45PTC-01	4.9
LH55	LH55PT-01	LH55PTC-01	4.9
LH65	LH65PT-01	LH65PTC-01	5.5

One of each PT and PTC is required to do one linear bearing.

Double Seal			Unit : mm
Linear Guide Model No.	Double Seal No. Plug End	Double Seal No. Grease Fitting End	Increased Thickness V2
LH15	LH15WS-01	LH15WSC-01	2.5
LH20	LH20WS-01	LH20WSC-01	2.5
LH25	LH25WS-01	LH25WSC-01	2.8
LH30	LH30WS-01	LH30WSC-01	3.6
LH35	LH35WS-01	LH35WSC-01	3.6
LH45	LH45WS-01	LH45WSC-01	4.3
LH55	LH55WS-01	LH55WSC-01	4.3
LH65	LH65WS-01	LH65WSC-01	4.9

One of each WS and WSC is required to do one linear bearing.

Fig-8 Protector and Double Seal

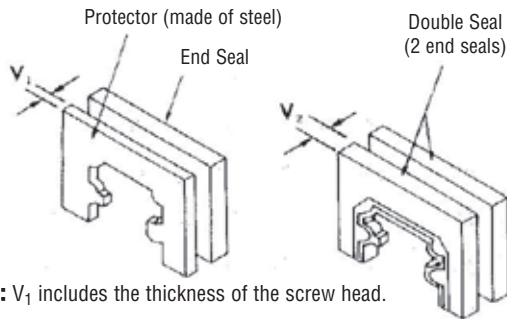

NOTE: V₁ includes the thickness of the screw head.

Fig-13

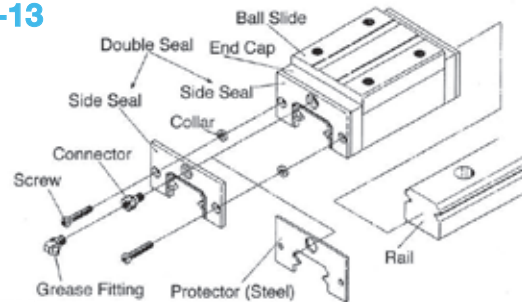

***NOTE:** The protector (steel) is always ahead of the side seal or double seal.

Adapters

These parts connect piping to the tapped hole when the grease fitting is removed.

Fig-6 LF Type

For LH20, 25
LH30, 35

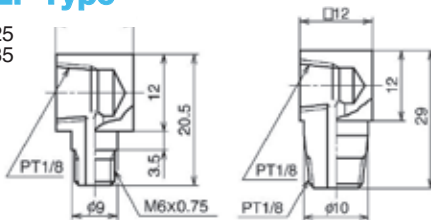

Reference No.:
L80206021-301

Reference No.:
L80200029-302

Fig-7 SF Type

For LH20, 25
LH30, 35

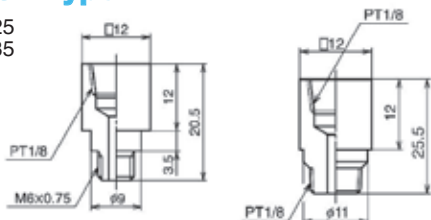

Reference No.:
L80106021-301

Reference No.:
L80100025-301

Plastic Cap for Rail Mounting Hole

Linear Guide Model No.	Rail Mounting Bolt Size	Cap. No. for Rail Mounting Hole
LH15	M4	L45800004-003
LH20	M5	L45800005-003
LH25	M6	L45800006-003
LH30	M8	L45800008-003
LH35		
LH45	M12	L45800012-003
LH55	M14	L45800014-003
LH65	M16	L45800016-003

Brass Cap for Rail Mounting Hole

Linear Guide Model No.	Rail Mounting Bolt Size	Cap. No. for Rail Mounting Hole
LH20	M5	L45800005-004
LH25	M6	L45800006-004
LH30	M8	L45800008-004
LH35		
LH45	M12	L45800012-004

LS Series

Identification Number

Refer to the following numbering system when ordering.

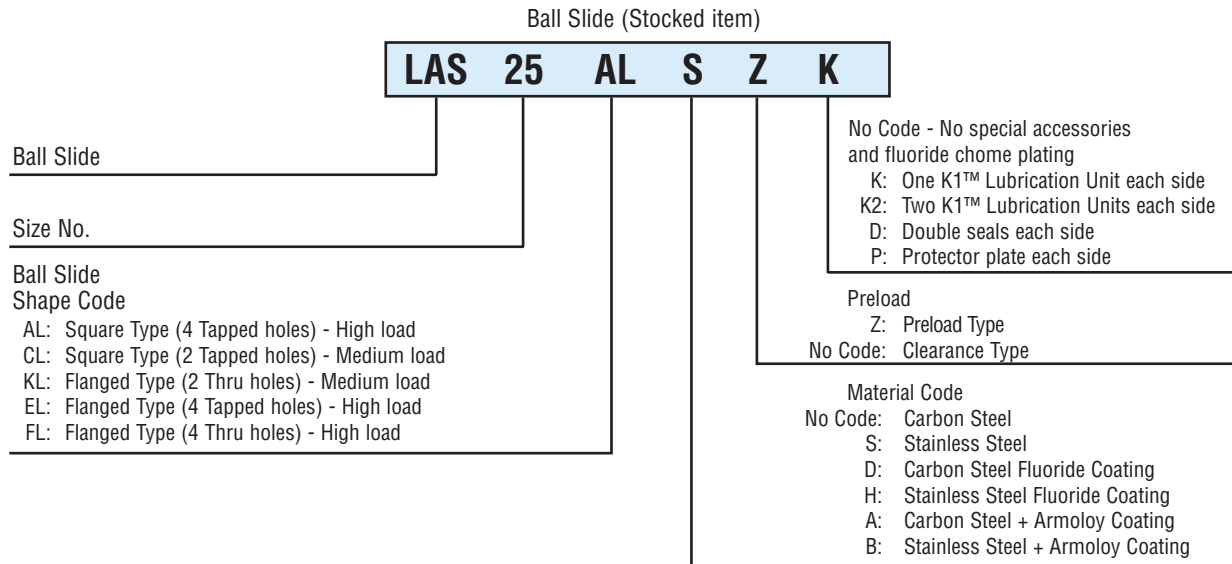

- Flanged Type
 - LS-EL (High Load) with 4 Tapped Holes
 - LS-FL (High Load) with 4 Thru Holes
 - LS-KL (Medium Load) with 2 Thru Holes
 - Square Type
 - LS-AL (High Load) with 4 Tapped Holes
 - LS-CL (Medium Load) with 2 Tapped Holes
- Both types have stainless steel series.

Fig.-1 LS-AL, LS-CL

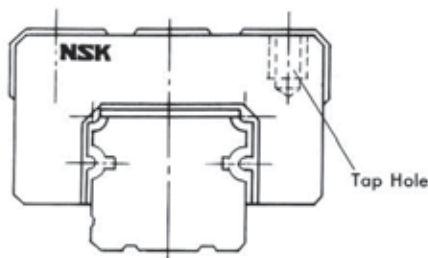
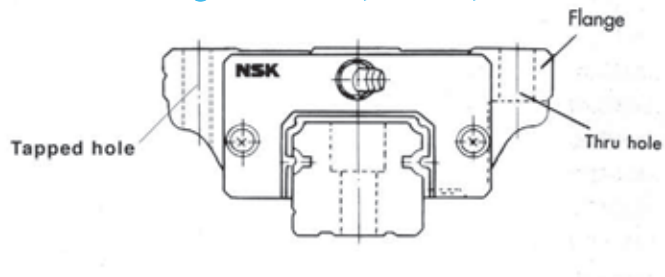

Fig.-2 LS-EL, LS-FL, LS-KL



Radial Clearance and Preload

The clearance when interchangeable rail and ball slide components are combined is as listed in Table 2. Minus symbol indicates the preload.

Table 2 Clearance of Interchangeable Linear Guide Unit: μm

Model No.	Clearance	Light Preload Z
LS15	15~-4	0~-4
LS20	15~-4	0~-4
LS25	15~-5	0~-5
LS30	15~-5	0~-5
LS35	15~-5	0~-6

*Consult NSK for price and delivery.

Accuracy Standard

The accuracy standard of the NSK “Compact Low Profile LS-Series” is shown in Table 1. With high-accuracy control of individual rail size and interchangeability, the accuracy of Table 1 can be maintained sufficiently even after addition or replacement of the ball slide.

Table 1 Tolerances Unit : μm

Tolerances (See Fig. 4 for Symbols)	Model No. LS
	15, 20, 25, 30, 35
Mounting Height H	± 20
Variation of Mounting Height	15 ⁽¹⁾ 30 ⁽²⁾
Mounting Width W_2 or W_3	± 30
Variation of Mounting Width W_2 or W_3	± 30
Running Parallelism of Face [C] to Face [A] Running Parallelism of Face [D] to Face [B]	Refer to Fig. 3

W_2 is applicable to the reference side only. Note: during installation the reference side is indicated by a line provided on the side of ball slide and rail. (See Fig. 4)
1. Variation on the same rail.
2. Variation on multiple rails.

Fig.-3 Running Parallelism

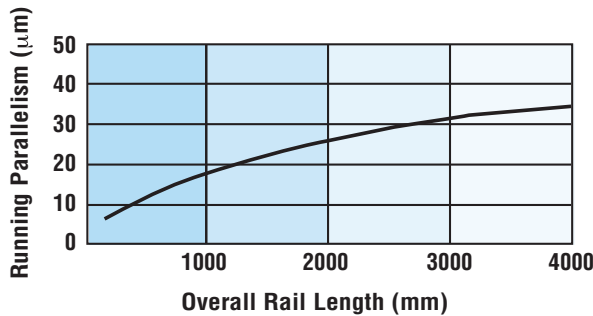
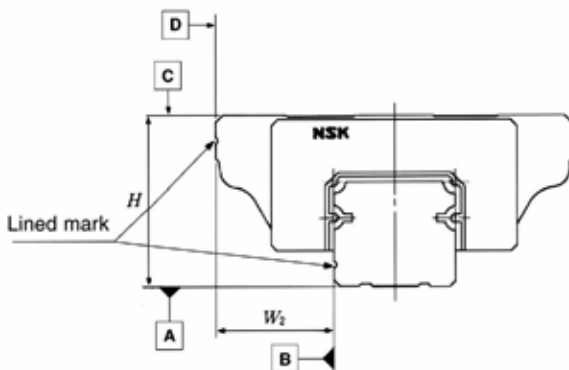

Fig.-4 Accuracy Standard



Load Rating and Life

The LS-Series is based on a design applying load from above. Therefore the dimension table shows the basic dynamic load rating C and basic static load rating C_0 for the downward direction. If the load is applied laterally or upward refer to values in Table 2.

Table 2 Basic Load Rating Correction for Direction

Load Direction	Basic Dynamic Load Rating	Basic Static Load Rating
Downward	C	C_0
Upward	C	$0.75C_0$
Laterally	$0.88C$	$0.63C_0$

Estimate the life of linear guides using the equation below.

Fig.-5

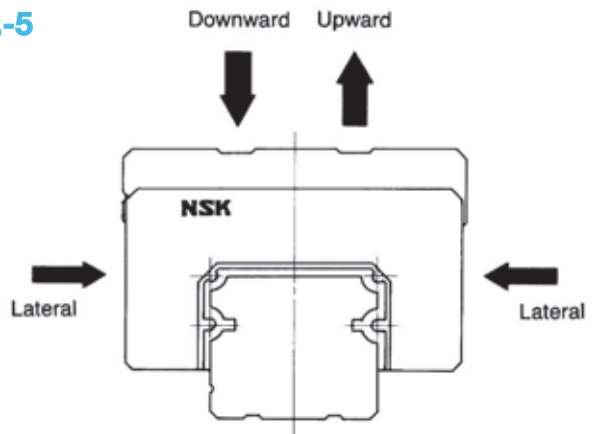

$$L = 50 \left(\frac{C}{f_W \cdot F} \right)^3$$

where, L : Rated fatigue life (km)
 C : Basic dynamic load rating (N)
 F : Load to a ball slide (N)
 (Dynamic equivalent load)
 f_W : Load factor
 $f_W = 1.0 \sim 1.2$ (Smooth condition)
 $f_W = 1.2 \sim 1.5$ (Normal condition)
 $f_W = 1.5 \sim 3.0$ (With shock or vibration)

LS Series

Ball Slide Dimension Table

Square Type

LAS-CL (Z) : Standard Steel

LAS-AL (Z) :

LAS-CLS (Z) : Stainless Steel

LAS-ALS (Z) :

Note: Consult NSK for price and delivery on stainless steel.

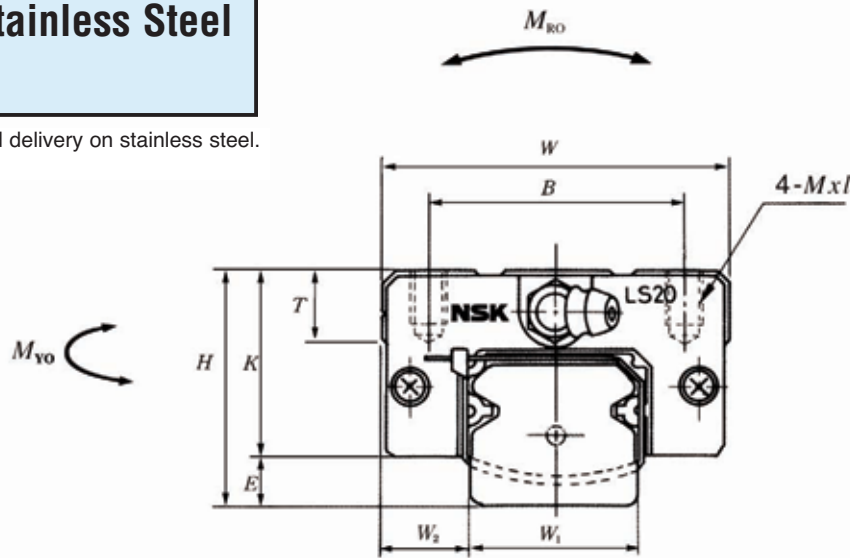

Model No.	Ass'y Dimensions			Ball Slide Dimensions								
	H	E	W ₂	W	B	L	L ₁	J	J ₁	K	T	M x pitch x l
LAS15 CL/CLZ LAS15 AL/ALZ	24	4.6	9.5	34	26	40.4 56.8	23.6 40	— 26	11.8 7	19.4	10	M4 x 0.7 x 6
LAS20 CL/CLZ LAS20 AL/ALZ	28	6	11	42	32	47.2 65.2	30 48	— 32	15 8	22	12	M5 x 0.8 x 7
LAS25 CL/CLZ LAS25 AL/ALZ	33	7	12.5	48	35	59.6 81.6	38 60	— 35	19 12.5	26	12	M6 x 1 x 9
LAS30 CL/CLZ LAS30 AL/ALZ	42	9	16	60	40	67.4 96.4	42 71	— 40	21 15.5	33	13	M8 x 1.25 x 12
LAS35 CL/CLZ LAS35 AL/ALZ	48	10.5	18	70	50	77 108	49 80	— 50	24.5 15	37.5	14	M8 x 1.25 x 12

Note: W₁ rail dimensions are on Page 20.

Refer to
pages 32 to 34 regarding
technical information for
the K1™ Maintenance-Free
Lubrication Unit

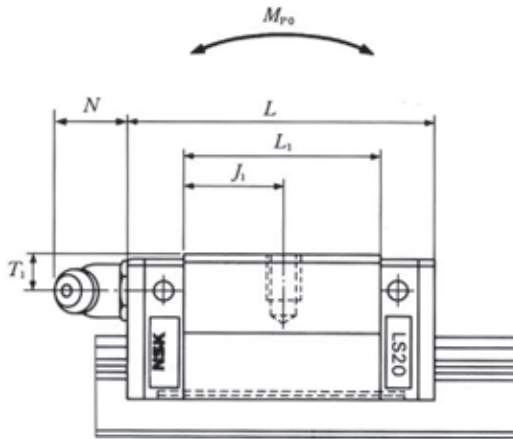

LAS-CL/CLZ

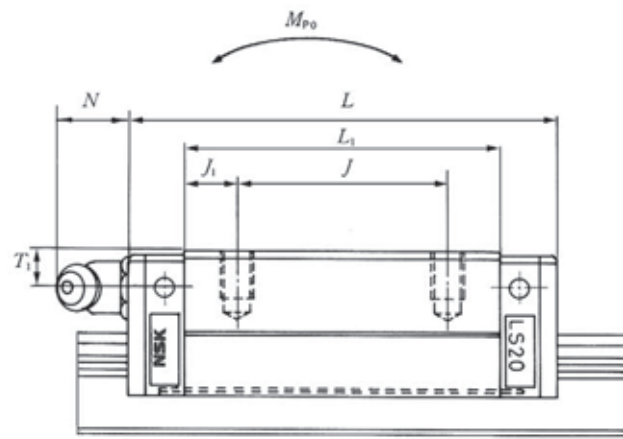

LAS-AL/ALZ

Unit : mm

Grease Fitting			Basic Load Ratings					Weight (kg)	Model No.
Mounting Hole Thread Spec.	T_1	N	Dynamic C (N)	Static C_0 (N)	Static Moment (N•m)				
					M_{RO}	M_{PO}	M_{YO}		
Ø3 (Thru Hole)	6	3	5400	9100	46	25	21	0.14	LAS15 CL/CLZ
			8350	16900	85	77	65	0.20	LAS15 AL/ALZ
M6 x 0.75	5.5	11	7900	13400	92	47	39	0.19	LAS20 CL/CLZ
			11700	23500	160	133	111	0.28	LAS20 AL/ALZ
M6 x 0.75	7	11	12700	20800	164	91	76	0.34	LAS25 CL/CLZ
			18800	36500	286	258	217	0.51	LAS25 AL/ALZ
M6 x 0.75	8	11	18700	29600	282	139	116	0.58	LAS30 CL/CLZ
			28800	55000	520	435	365	0.85	LAS30 AL/ALZ
M6 x 0.75	8.5	11	26000	40000	465	220	185	0.86	LAS35 CL/CLZ
			40000	74500	865	695	580	1.25	LAS35 AL/ALZ

LS Series

Ball Slide Dimension Table

Flange Type

LAS-KL (Z) : Standard Steel

LAS-FL (Z) :

LAS-EL (Z) :

LAS-KLS (Z) : Stainless Steel

LAS-KLS (Z) :

Note: Consult NSK for price and delivery on stainless steel.

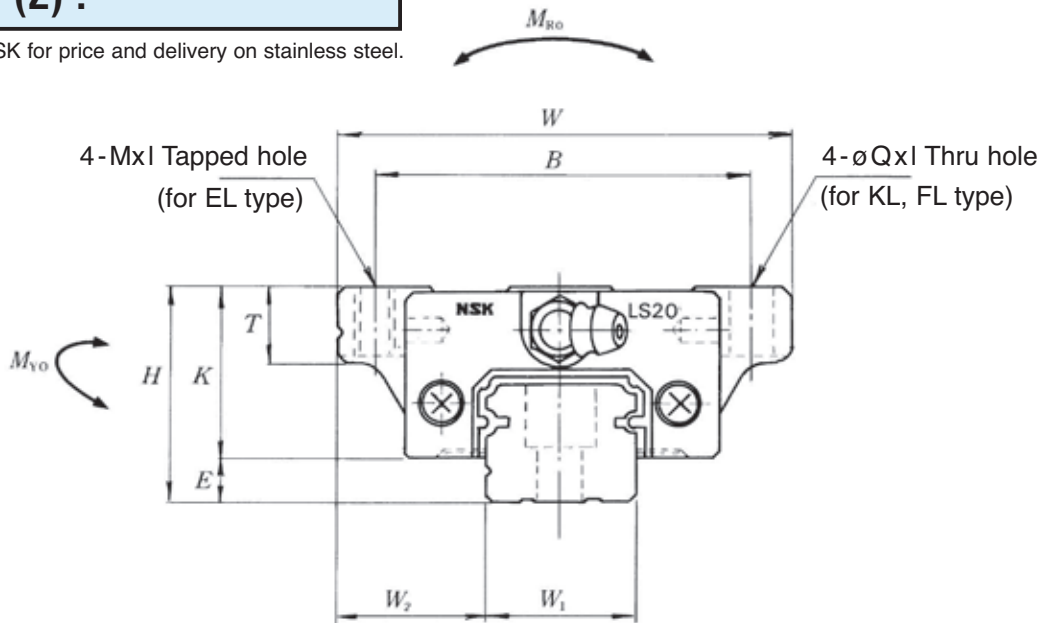

Model No.	Ass'y Dimensions			Ball Slide Dimensions									Bolt Size Thru Hole Q	
	H	E	W ₂	W	B x J	L	L ₁	J ₁	K	T	Q x I	M x pitch x I		
LAS15 KL/KLZ	24	4.6	18.5	52	41 x 26	40.4	23.6	11.8	19.4	8	4.5 x 7	M5 x 0.8 x 8	M4	
LAS15 FL/FLZ					41 x 26	56.8	40.0	7.0						4.5 x 7
LAS15 EL/ELZ					41 x 26	56.8	40.0	7.0						
LAS20 KL/KLZ	28	6.0	19.5	59	49 x 32	47.2	30.0	15.0	22.0	10	5.5 x 9	M6 x 1 x 9	M5	
LAS20 FL/FLZ					49 x 32	65.2	48.0	8.0						5.5 x 9
LAS20 EL/ELZ					49 x 32	65.2	48.0	8.0						
LAS25 KL/KLZ	33	7.0	25.5	73	60 x 35	59.6	38.0	19.5	26.0	11	7 x 10	M8 x 1.25 x 12	M6	
LAS25 FL/FLZ					60 x 35	81.6	60.0	12.5						7 x 10
LAS25 EL/ELZ					60 x 35	81.6	60.0	12.5						
LAS30 KL/KLZ	42	9.5	31.0	90	72 x 40	67.4	42.0	21.5	33.5	11	9 x 12	M10 x 1.5 x 12	M8	
LAS30 FL/FLZ					72 x 40	96.4	71.0	15.5						9 x 12
LAS30 EL/ELZ					72 x 40	96.4	71.0	15.5						
LAS35 KL/KLZ	48	10.5	33.0	100	80 x 50	77.4	49.0	24.5	37.5	12	9 x 13	M10 x 1.5 x 12	M8	
LAS35 FL/FLZ					82 x 50	108.0	80.0	15.0						9 x 13
LAS35 EL/ELZ					82 x 50	108.0	80.0	15.0						

Note: W₁ rail dimensions are on Page 20.

LS Series

Refer to
pages 32 to 34 regarding
technical information for
the K1™ Maintenance-Free
Lubrication Unit

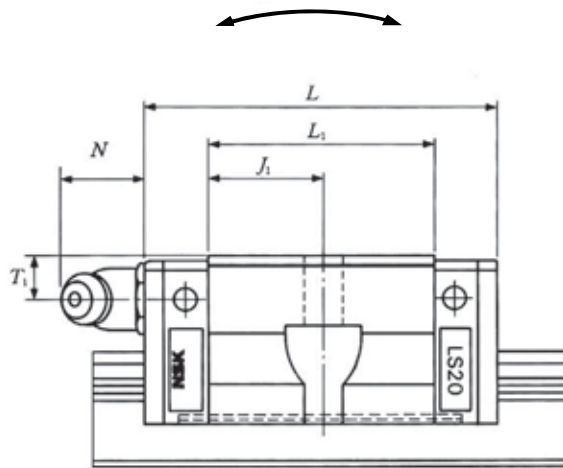

LAS-KL/KLZ

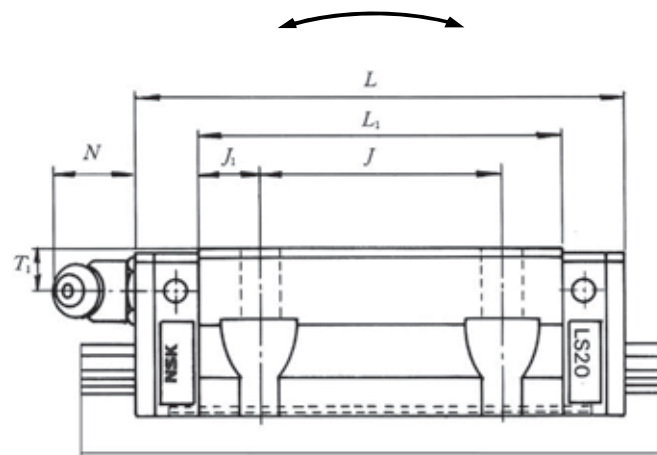

**LAS-FL/FLZ
LAS-EL/ELZ**

Unit : mm

Grease Fitting			Basic Load Ratings					Weight (kg)	Model No.
Mounting Hole Thread Spec.	T_i	N	Dynamic C (N)	Static C_0 (N)	Static Moment (N·m)				
					M_{R0}	M_{P0}	M_{V0}		
Ø3 (Thru Hole)	6.0	3	5400	9100	46	25	21	0.17	LAS15 KL/KLZ LAS15 FL/FLZ LAS15 EL/ELZ
			8350	16900	85	77	65	0.26	
			8350	16900	85	77	65	0.26	
M6x0.75	5.5	11	7900	13400	92	47	39	0.24	LAS20 KL/KLZ LAS20 FL/FLZ LAS20 EL/ELZ
			11700	23500	160	133	111	0.35	
			11700	23500	160	133	111	0.35	
M6x0.75	7.0	11	12700	20800	164	91	76	0.44	LAS25 KL/KLZ LAS25 FL/FLZ LAS30 EL/ELZ
			18800	36500	286	258	217	0.66	
			18800	36500	286	258	217	0.66	
M6x0.75	8.0	11	18700	29600	282	139	116	0.76	LAS30 KL/KLZ LAS30 FL/FLZ LAS30 EL/ELZ
			28800	55000	520	435	365	1.2	
			28800	55000	520	435	365	1.2	
M6x0.75	8.5	11	26000	40000	465	220	185	1.2	LAS35 KL/KLZ LAS35 FL/FLZ LAS35 EL/ELZ
			40000	74500	865	695	580	1.7	
			40000	74500	865	695	580	1.7	

LS Series

Rail Dimension Table

Separately Sold Rail for NSK Linear Guide

LS Series Standard Rail

L1S : Clearance Interchangeable Type

L1S-Z : Preloaded Interchangeable Type

Identification Number

Rail

L1S 25 3960 -01 T S Z

Type Slide

Size No.

Rail Length (mm)

No Code: Standard
-01: Butted Rail

For L1S15 Rail Size Only:

No Code: Counterbore hole in rail for M3
T: Counterbore hole in rail for M4

Preload Code

Z: Light preload

No Code: Clearance type

Material Code

No Code: Carbon Steel

S: Stainless Steel

D: Carbon Steel + Fluoride Coating

H: Stainless Steel + Fluoride Coating

A: Carbon Steel + Armoloy Coating

B: Stainless Steel + Armoloy Coating

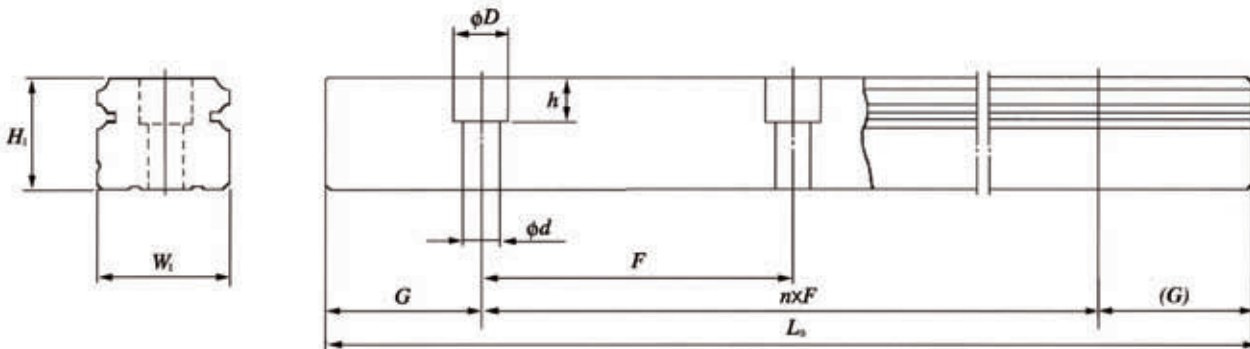

Unit : mm

Model No.	Rail Dimensions							Weight Rail (kg/m)
	Width W_1	Height H_1	Pitch F	Bolt Hole $d \times D \times H$	Rail Butting G	Rail Standard G	Max. Rail Length L_0 () indicates Stainless Steel	
L1S15	15	12.5	60	3.5 x 6 x 4.5	30	20	1660 (1000)	1.4
L1S15T	15	12.5	60	4.5 x 7.5 x 5.3	30	20	1660 (1000)	1.4
L1S20	20	15.5	60	6 x 9.5 x 8.5	30	20	3960 (3400)	2.3
L1S25	23	18.5	60	7 x 11 x 9	30	20	3960 (3400)	3.1
L1S30	28	23.5	80	7 x 11 x 9	40	20	4000 (3400)	4.8
L1S35	34	27.5	80	9 x 14 x 12	40	20	4000 (3400)	7.0

LS Series Accessories

Protector and Double Seal

Travel length is reduced by the thickness of the end seal on the ball slide. Consider the value of V in the table below when calculating the travel length.

Protector Seal			Unit : mm
Linear Guide Model No.	Protector No. Plug End	Protector No. Grease Fitting End	Increased Thickness V1
LS15	LS15PT-01	LS15PTC-01	3.0.0
LS20	LS20PT-01	LS20PTC-01	2.7
LS25	LS25PT-01	LS25PTC-01	3.2
LS30	LS30PT-01	LS30PTC-01	4.2
LS35	LS35PT-01	LS35PTC-01	4.2

One of each PT and PTC is required to do one linear bearing.

Double Seal			Unit : mm
Linear Guide Model No.	Double Seal No. Plug End	Double Seal No. Grease Fitting End	Increased Thickness V2
LS15	LS15WS-01	LS15WSC-01	2.8
LS20	LS20WS-01	LS20WSC-01	2.5
LS25	LS25WS-01	LS25WSC-01	2.8
LS30	LS30WS-01	LS30WSC-01	3.6
LS35	LS35WS-01	LS35WSC-01	3.6

One of each WS and WSC is required to do one linear bearing.

Fig.-7 Protector and Double Seal

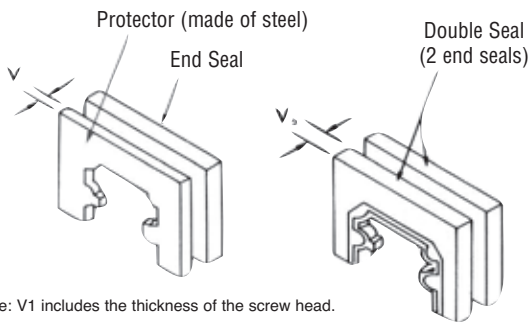

Note: V1 includes the thickness of the screw head.

Fig.-13

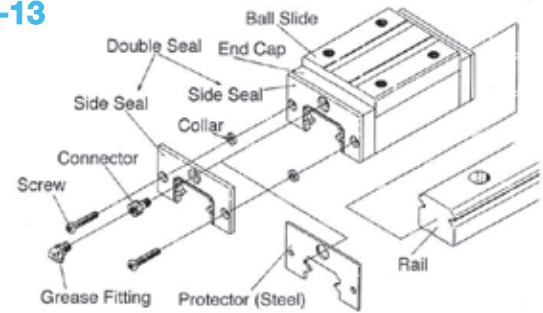

*Note: The protector (steel) is always ahead of the side or double seal.

Adapter

These parts connect piping to the tapped hole when the grease fitting is removed.

Fig.-5 LF Type Adapter No. L80206021-301

For LS20, 25
For LS30, 35

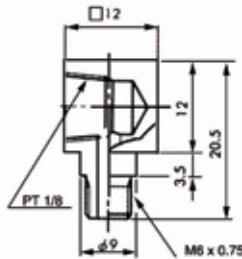

Fig.-6 SF Type Adapter No. L80106021-301

For LS20, 25
For LS30, 35

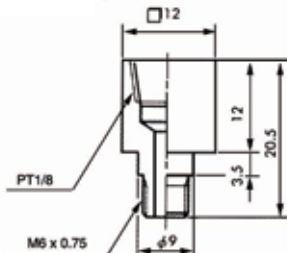

Table 12 Cap for Rail Mounting Hole

Linear Guide Model No.	Rail Mounting Bolt Size	Cap. No. for Rail Mounting Hole
LS15	M3	L45800003-003
LS20	M5	L45800005-003
LS25	M6	L45800006-003
LS30		
LS35	M8	L45800008-003

Brass Cap for Rail Mounting Hole

Linear Guide Model No.	Rail Mounting Bolt Size	Cap. No. for Rail Mounting Hole
LS20	M5	L45800005-004
LS25	M6	L45800006-004
LS30		
LS35	M8	L45800008-004

LU Series

Identification Number

Refer to the following numbering system when ordering.

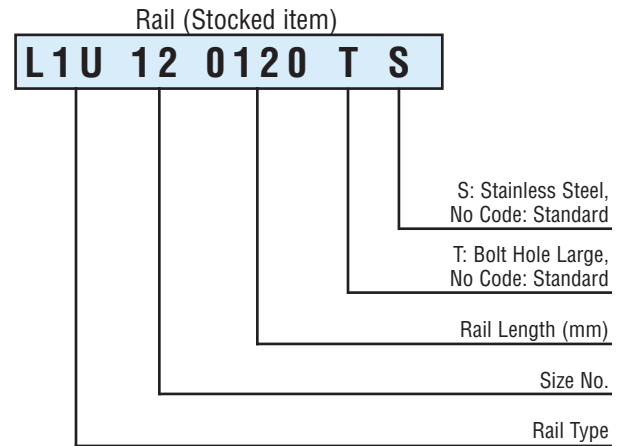
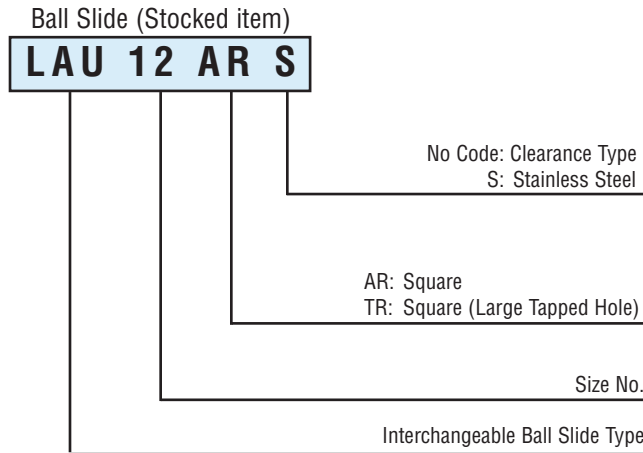

Ball Slide

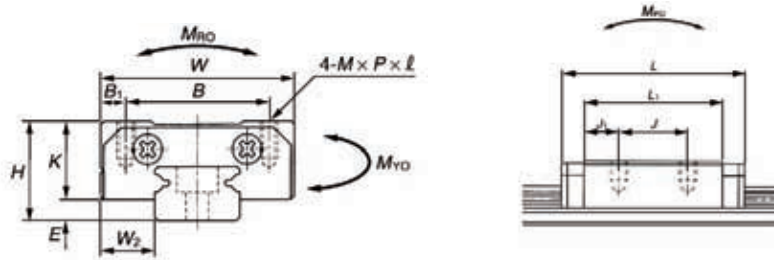

LU Series Ball Slide Dimension

Unit: mm

Model No.	Ass'y Dimension			Ball Slide Dimensions										Basic Load Rating			Weight (g)	
	Height H	E	Width W ₂	Length W	L	B	Tapped Hole			L ₁	J ₁	K	Dynamic C (N)	Static C ₀ (N)	Static Moment (N•m)			
							J	M x pitch x l	B ₁						M _{RO}	M _{PO}		M _{YO}
LAU09ARS LAU09TRS	10	2.2	5.5	20	30	15	13 10	M2 x 0.4 x 2.5 M3 x 0.5 x 3	2.5	20	3.5 5.5	7.8	1490	2150	10 10	6 6	6 6	19
LAU12ARS LAU12TRS	13	3	7.5	27	35.2	20	15	M2.5 x 0.45 x 3 M3 x 0.5 x 3.5	3.5	21.8	3.4	10	2830	3500	21 21	11 11	11 11	38
LAU15ALS	16	4	8.5	32	43.6	25	20	M3 x 0.5 x 4	3.5	27	3.5	12	5550	6600	50	26	26	70

Rail

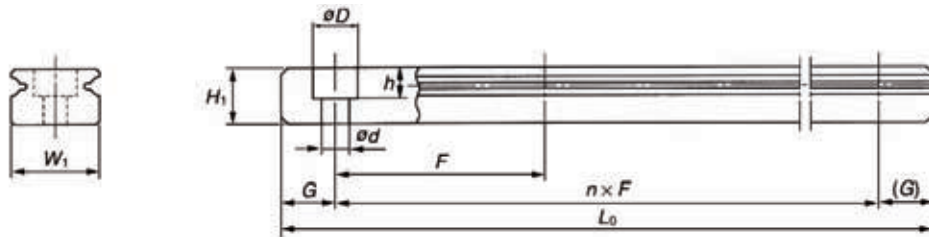

LU Series Rail Dimension

Unit: mm

Model No	Standard Length (in stock)			Rail Dimension					Rail length L ₀ max () indicates Stainless Steel	Weight (g/100mm)	
				Width W ₁	Length H ₁	Bolt pitch F	Bolt hole d x D x h	G (Standard)			
L1U09*S L1U09*TS	115	195	275	9	5.5	20	2.6 x 4.5 x 3 3.5 x 6 x 4.5	7.5	275 (600)	35	
L1U12*S L1U12*TS	170	270	470	800	12	7.5	25	3 x 5.5 x 3.5 3.5 x 6 x 4.5	10	470 (470)	65
L1U15*S	230	430	670	990	15	9.5	40	3.5 x 6 x 4.5	15	990 (990)	105

*Stainless Steel

Courtesy of Steven Engineering, Inc. - 230 Ryan Way, South San Francisco, CA 94080-5370 - Main Office: (650) 588-9200 - Outside Local Area: (800) 258-9200 - www.stevenengineering.com

LE Series

Identification Number

Refer to the following numbering system when ordering.

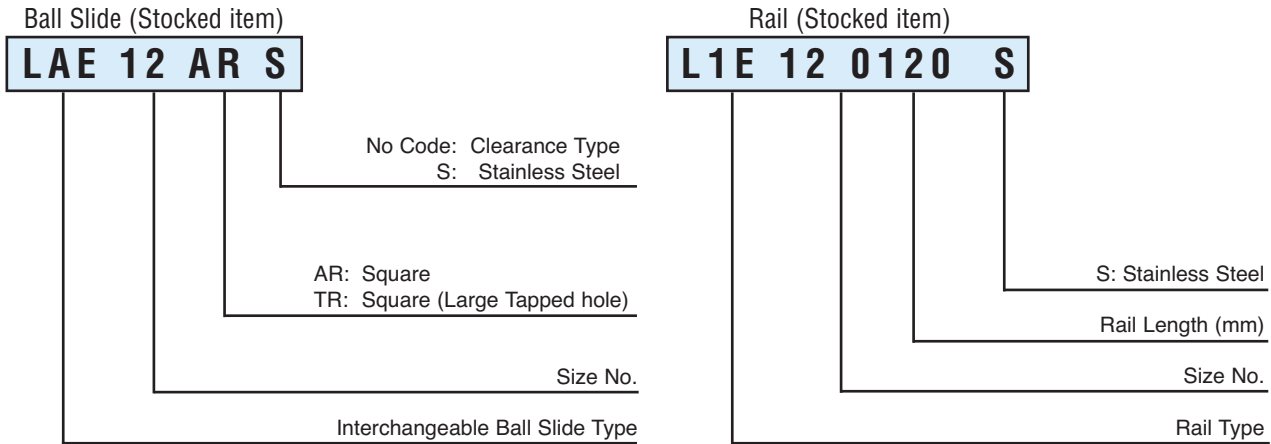

Ball Slide

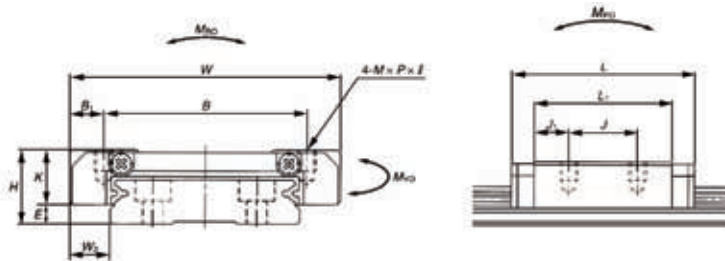

LE Series Ball Slide Dimension

Unit: mm

Model No.	Ass'y Dimension			Ball Slide Dimensions								Basic Load Rating					Weight (g)		
	Height H	E	W ₂	Width W	Length L	B	J	Tapped Hole		B ₁	L ₁	J ₁	K	Dynamic C (N)	Static C ₀ (N)	Static Moment (N·m)			
								Thread M x pitch x l								M _{RO}		M _{PO}	M _{YO}
LAE09ARS LAE09TRS	12	4	6	30	39.8	21	12	M2.6 x 0.45 x 3 M3 x 0.5 x 3	4.5	27.6	7.8	8	3000	4500	37	17	17	40	
LAE12ARS	14	4	8	40	45	28	15	M3 x 0.5 x 4	6.0	31	8	10	4350	6350	71	29	29	75	
LAE15ARS	16	4	9	60	56.6	45	20	M4 x 0.7 x 4.5	7.5	38.4	9.2	12	7600	10400	207	25	59	150	

Rail

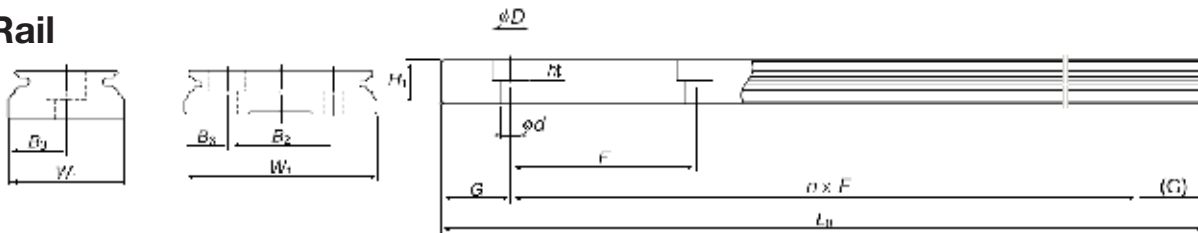

LE Series Rail Dimension

Unit: mm

Model No.	Standard Length (in stock)			Rail Dimension									Weight (g/100mm)
				Width W ₁	Length H ₁	Bolt pitch F	B ₂	B ₃	Bolt hole d x D x h	G hole (Standard)	Rail length L ₀ max		
L1E09*S	110	200	290	380	18	7.5	30	-	9.5	3.5 x 6 x 4.5	10	380	95
L1E12*S	150	310	470	790	24	8.5	40	-	12.5	4.5 x 8 x 4.5	15	790	140
L1E15*S	230	430	670	990	42	9.5	40	23	9.5	4.5 x 8 x 4.5	15	990	275

*Stainless Steel

LW Series

Identification Number

Refer to the following numbering system when ordering.

Ball Slide (Stocked item)

LAW 27 EL Z

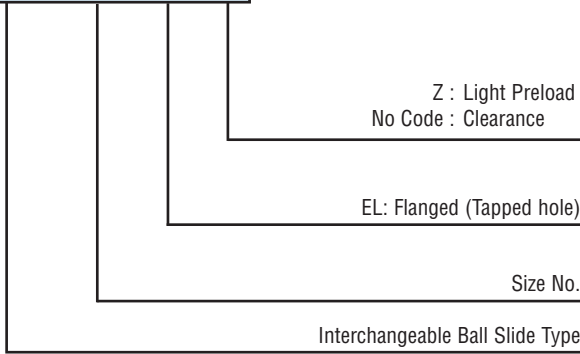

Rail (Stocked item)

L1W 27 0820 Z

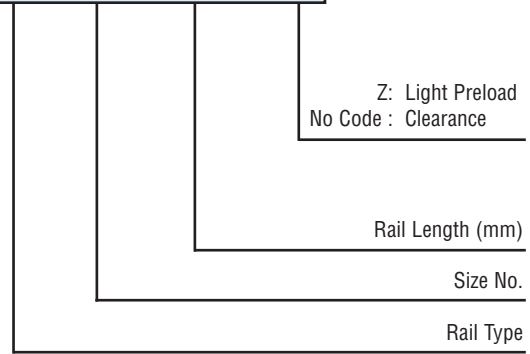

Ball Slide

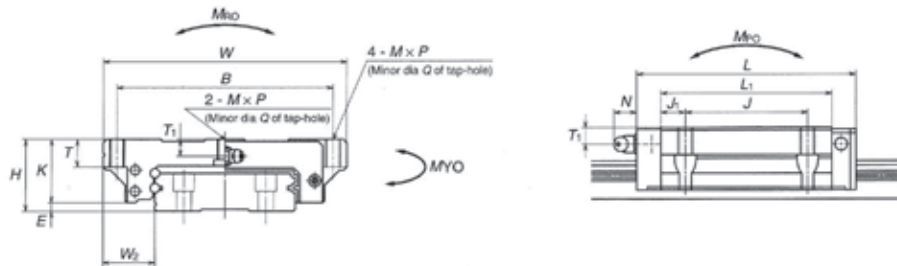

LW Series Ball Slide Dimension

Unit: mm

Model No.	Assembly Dimension					Ball Slide Dimensions											Basic Load Rating					Weight (kg)
	Height H	E	W ₂	Width W	Length L	Tapped Hole				Grease fitting							Dynamic C _d (N)	Static C _s (N)	Static Moment (N·m)			
						B x J	Thread M x pitch x l	T ₁	Q	L ₁	J	K	T	Thread	T ₁	N			M _{Ro}	M _{Po}	M _{Yo}	
LAW17EL/ELZ	17	2.5	13.5	60	51.4	53 x 26	M4 x 0.7 x 6	3.2	3.3	35	4.5	14.5	6	ø3 thru hole	4	3	5600	11300	113	44	37	0.2
LAW21EL/ELZ	21	3	15.5	68	58.8	60 x 29	M5 x 0.8 x 8	3.7	4.4	41	6	18	8	M6 x 0.75	4.5	11	6450	13900	185	66	55	0.3
LAW27EL/ELZ	27	4	19	80	74	70 x 40	M6 x 1 x 10	6	5.3	56	8	23	10	M6 x 0.75	6	11	12800	26900	400	171	143	0.5
LAW35EL/ELZ	35	4	25.5	120	108	107 x 60	M8 x 1.25 x 14	8	6.8	84	12	31	14	M6 x 0.75	8	11	33000	66500	1690	645	545	1.5
LAW50EL/ELZ	50	4.5	36	162	140.6	144 x 80	M10 x 1.5 x 18	14	8.6	108	14	45.5	18	PT 1/8	14	14	61500	117000	3900	1530	1280	4.0

Rail

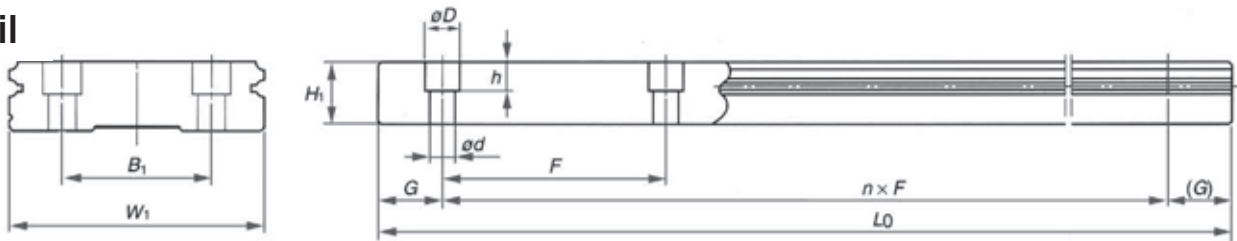

LW Series Rail Dimension

Unit: mm

Model No.	Standard Length (in stock)					Rail Dimension					Rail length L ₀ max	Weight (kg/m)	
						Width W ₁	Height H ₁	Bolt pitch F	B ₁	Bolt hole d x D x h			G (Standard)
L1W17	430	670	990			33	8.7	40	18	4.5 x 7.5 x 5.3	15	990	2.1
L1W21	430	680	980			37	10.5	50	22	4.5 x 7.5 x 5.3	15	980	2.9
L1W27	460	640	820	1000		42	15	60	24	4.5 x 7.5 x 5.3	20	2000	4.7
L1W35	440	600	760	1000	1240	69	19	80	40	7 x 11 x 9	20	2000	9.6
L1W50	440	600	760	1000	1240	90	24	80	60	9 x 14 x 12	20	1240	15.8

Assembly

Interchangeable ball slides are shipped on (disposable) plastic provisional rails as shown in Fig.-9.

1. Wipe off anticorrosive oil from the rail.
2. Since Alvania (AS2) grease is packed in the ball slide, you can use it as delivered.
3. Align the rail with bottom and side faces of provisional rail and while pushing the provisional rail lightly against the rail, slide the ball slide on to the rail (Fig.-9).

Fig.-9 Assembly of Ball Slide with Rail

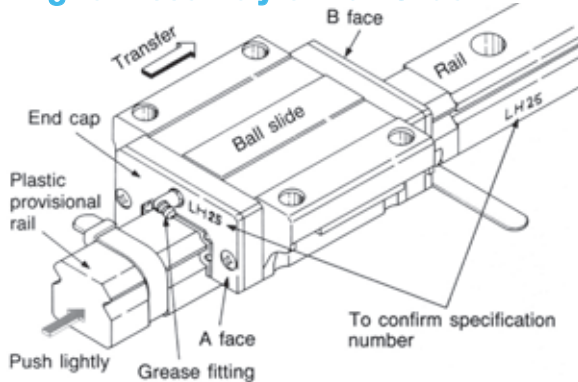

Mounting Method

Shoulder Height and Corner Shape at Mounting Face

When utilizing the reference surface to secure rail or ball slides to machine components the components must have the mounting face height (H', H'') and corner chamfer (r) dimensions as listed in Table 6 and illustrated in Figs. 10 and 11, to avoid interference.

Table 6 Shoulder height and corner shape at mounting face (LH, LS Series) Unit : mm

Product No.	Radius of corner r (max.)	Shoulder Height of Rail H'	Shoulder Height of Ball Slide H''
15	0.5	4.0	4.5
20	0.5	4.5	5.0
25	0.5	5.0	5.0
30	0.5	6.0	6.0
35	0.5	6.0	6.0
45	0.7	8.	8.0
55	0.7	10.0	10.0
65	1.0	11.0	11.0

Fig.-10 Rail Datum Face Mounting Part



Fig.-11 Ball Slide Datum Face Mounting Part

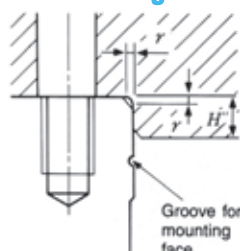

Mounting Procedure

For cases where datum surface exists on the bed

1. Lightly tighten the rail mounting bolts and then use the shoulder plate to secure rail datum surface against bed mounting surface (See Fig. 12).
2. Tighten rail mounting bolts to their recommended torques (Table 7). Tighten the bolts in an order which enables the wrench to help push the rail against the mounting surface (see Fig. 13 for example).

Fig.-12 Positioning of Rail

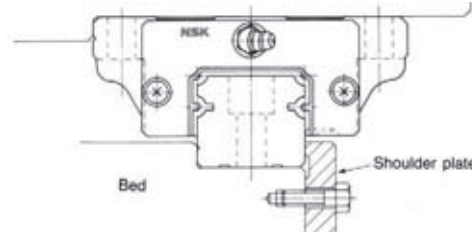
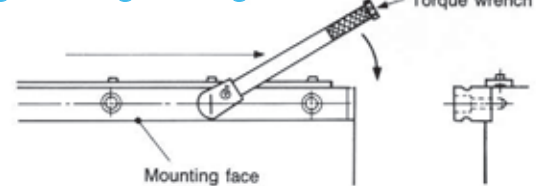

Table 7 Recommended Torque for Rail Mounting Bolt (case of thermally refined bolt) Unit: kgf•cm

Bolt Nominal No.	Torque	Bolt Nominal No.	Torque
M3	10.8	M10	440
M4	25.0	M12	770
M5	52.0	M14	1240
M6	88.0	M16	2000
M8	220.0	[1 kg•cm=0.8681 Lb in]	

Fig.-13 Tightening Direction



3. Mount the adjust side rail, as shown in Fig.-14, while checking rail parallelism. For the jig shown in Fig.-14, stability will be improved by mounting it on 2 ball slide.

Fig.-14 Parallelism Measurement with Jigs

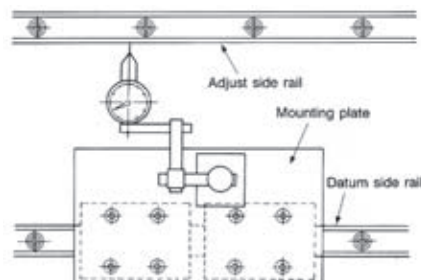

4. If dowel pins are being used they should be installed at this step.
5. Position the ball slides at specified intervals and mount the table gently.
6. Tighten ball slide mounting bolts of datum side while pushing the table so that the table and ball slide mounting reference surfaces are in contact.

Indication of Installed Standard Side

The datum face of each rail is indicated by a groove in the datum face or by an arrow mark on the end or top surface of the rail.

Model	LU09 LE Series (all models)	LU12,15
High-carbon steel		
Stainless steel		

The datum face is indicated by a groove

Lubrication

Grease Lubrication

NSK linear guides are packed with Alvania 2 grease and can be used as delivered. The replenishment frequency is recommended to be once a year, but adjust the interval depending on the operation conditions.

(1) To Change Direction of Grease Fitting

1. Remove the grease fitting with a wrench.
2. Wind some sealing tape on the thread of the fitting, then insert it and tighten. Be careful not to over torque when tightening into the side of the plastic bearing end cap.

(2) Change of Fitting Position in Front/Back Direction

1. Remove the plug from the grease fitting mounting hole face B shown in Fig.-9 with a hexagonal wrench.
2. Remove the grease fitting from face A and screw into hole face B.
3. In place of the removed fitting, insert the plug into the hole in the face A.

(3) Change Grease Fitting Position to Side Surface

To mount the grease fitting on the end cap side face, or on the ball slide face, please consult NSK.

Oil Lubrication

Oil piping can be connected to the tapped hole from where the grease fitting was removed. Piping joints are listed on page 13 and page 21. The recommended lubrication oil supply quantity per ball slide per hour Q is given by the following formula, where N is the rail width number.

$$Q = \frac{N}{150} \text{ (ml/hr)} \dots \dots \dots (5)$$

Using LH45 as an example, N=45, and

$$Q = \frac{45}{150} = 0.3 \text{ (ml/hr)}$$

Notes on Usage

Separately packaged ball slide is mounted on a plastic temporary axis (disposable) as shown at left.

1. Wipe anti-rust oil from the rail.
2. Product is ready for use as is since Alvania 2 grease is sealed inside the ball slide.
3. Note the groove mark which identifies the datum faces of ball slide and rail above.
4. Move the ball slide, matching and slightly pushing the base and the side of provisional rail to the rail as in drawing at left.

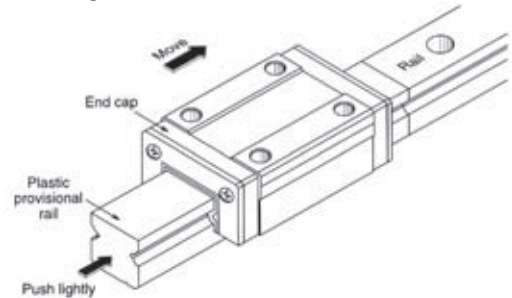

Grease Fittings for NSK Ball Slides

Type	Linear Guide Model #	Grease Fitting Part #	Thread Spec.
Drive	LH15, LS15, LW17	L50010000-301	Dia. 3mm
A	LH,LS 20,25,30,35	L50000000-001	M6X0.75MM
B	Same	L50100000-001	M6X0.75MM
C	Same plus LW21, 27, 35	L50200000-001	M6X0.75MM
A	LH 45, 55, 65	L50003000-001	PT 1/8
B	Same	L50103000-001	PT 1/8
C	Same plus LW50	L50203000-001	PT 1/8

Fig.-15 Shape of Grease Fitting

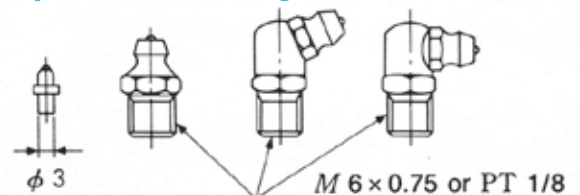

(1) Drive-in type A type B type C type
Standard types

(1) Applies only to Model No. LH15, LS15 and LW17.

NSK Grease Unit

Replenish grease to NSK linear guides and ball screws by a manual type hand grease pump. Install the grease in bellows tube to the pump. Several types of grease (80 g) are available.



Grease in a bellows tube



(1) Composition of NSK Grease Unit

Components and grease types are shown below.

NSK Grease Unit		Name	(Tube Type)	Reference Number
NSK Grease (80 g in a bellows tube)	NSK Grease AS2	(Brown)	NSK GRS AS2	
	NSK Grease PS2	(Orange)	NSK GRS PS2	
	NSK Grease LR3	(Green)	NSK GRS LR3	
	NSK Grease LG2	(Blue)	NSK GRS LG2	
NSK Hand Grease Pump Unit				
	NSK Hand Grease Pump (Straight nozzle NSK HGP NZ1 -- One nozzle is provided with the hand pump.)			NSK HGP
	Grease nozzle (used with the hand grease pump)			
	NSK straight nozzle			NSK HGP NZ1
	NSK chuck nozzle			NSK HGP NZ2
	NSK drive fitting nozzle			NSK HGP NZ3
	NSK point nozzle			NSK HGP NZ4
	NSK flexible nozzle			NSK HGP NZ5
	NSK flexible extension pipe			NSK HGP NZ6
	NSK straight extension pipe			NSK HGP NZ7

(2) NSK Greases (80 g in a bellows tube)

Bellows Tube

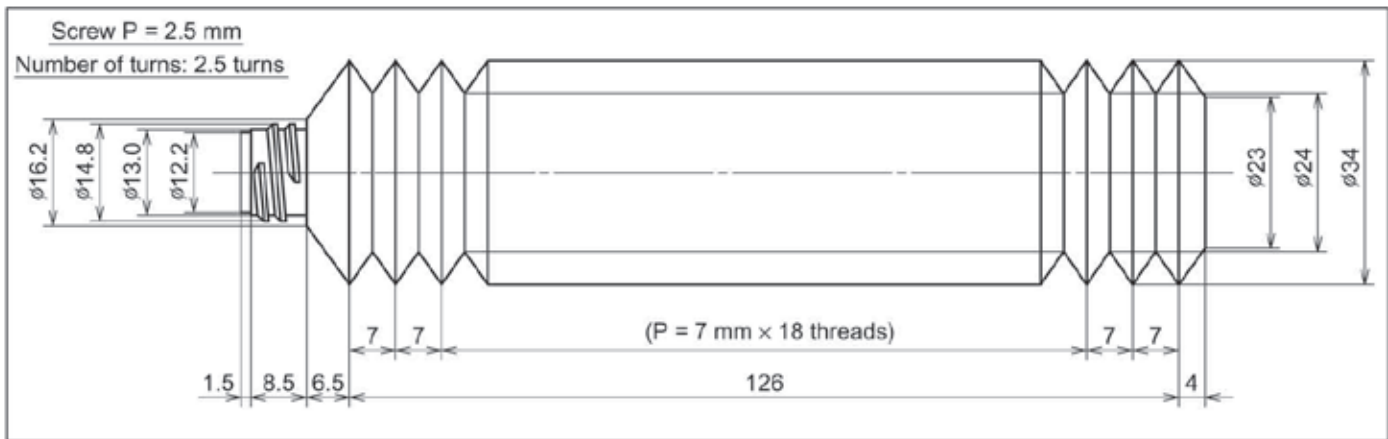

(3) NSK Manual Grease Pump Unit

1. NSK Hand Grease Pump Unit (Reference Number: NSK HGP)

• Features

- Light-weight Can be operated by one hand, yet there is no worry to making a mistake.
- Inserting by high pressure . . . Insert at 15 Mpa.
- No leaking Does not leak when held upside down.
- Easy to change grease Simply attach the grease in bellows tube.
- Remaining grease Can be confirmed through slit on the tube.
- Several nozzles Five types of nozzles to choose from.

• Specifications

- Spout volume 0.35 g/stroke
- Mass of main body 393 g
- Overall length About 200 mm
- Overall width About 200 mm
- Grease tube outer diameter Ø38.1
- Accessory Several nozzles for a unique application can be attached

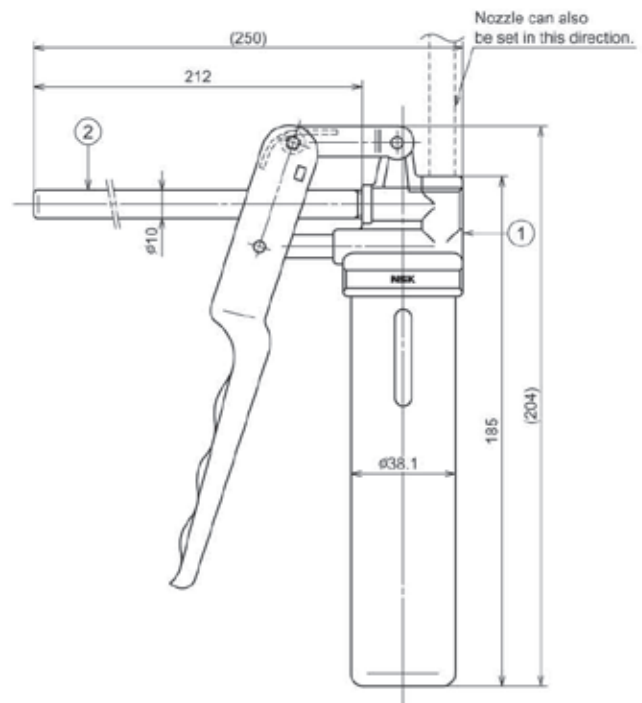

Fig. 2-3 NSK Hand Grease Pump with NSK Straight Nozzle

(2) Nozzles

Nozzles that can be attached to NSK Hand Grease Pump

Name	Designation Code	Use	Dimensions
NSK straight nozzle	NSK HGP NZ1	Can be used with grease fitting A, B, and C under JIS B1575 standard.	
NSK chuck nozzle	NSK HGP NZ2	Same as above. However, there is no need to press the hand pump because the grease fitting and the nozzle come to contact due to the chucking mechanism at the tip.	
NSK fitting nozzle	NSK HGP NZ3	Dedicated for the - f3 drive-in grease fitting.	
NSK point nozzle	NSK HGP NZ4	Used for linear guides and ball screws which do not have grease fitting. Supplies grease directly to the ball grooves, or through the opening of ball slide or ball slide to inside.	
NSK flexible nozzle	NSK HGP NZ5	The tip of the flexible nozzle is chuck nozzle. Used to supply grease to the area where hand cannot reach.	
NSK flexible extension pipe	NSK HGP NZ6	Flexible extension pipe connects the grease pump and the nozzle.	
NSK straight extension pipe	NSK HGP NZ7	Straight extension pipe connects the grease pump and the nozzle.	

Grease Lubricant for Linear Guides and Ball Screws

Type	Thickener	Base oil	Base oil kinematic viscosity cSt (40°C)	Range of use temperature (°C)	Purpose
AS2	Lithium type	Mineral oil	130	-10~110	For ball screws and linear guides for general use at high load.
PS2	Lithium type	Synthetic oil + mineral oil	15	-50~110	For ball screws and linear guides for low temperature and high frequency operation.
LR3	Lithium type	Synthetic oil	30	-30~130	For ball screws at high speed, medium load.
LG2	Lithium type	Synthetic oil + synthetic hydrocarbon oil	30	-10~80	For ball screws and linear guides for clean environment.
NF2	Urea composite type	Synthetic oil + mineral oil	27	-40~100	For fretting resistant ball screws and linear guides.

Grease Nozzle Used for NSK Linear Guide

Linear guide model	Tap hole for grease fitting	Standard grease fitting	Straight nozzle NZ1	Chuck nozzles (two) NZ	Drive-in nipple nozzle NZ3	Point nozzle NZ4	Flexible nozzle NZ5
LS15	∅ 3	Drive-in type			0		
LS20 ~35	M6 x 0.75	B type	0	0			0
LH15	∅ 3	Drive-in type			0		
LH20 ~35	M6 x 0.75	B type	0	0			0
LH45 ~85	PT1 / 8	B type	0	0			0
LW17	∅ 3	Drive-in type			0		
LW21 ~35	M6 x 0.75	B type	0	0			0
LW50	PT/18	B type	0	0			0
LU09 ~15	-	None				0 ⁽²⁾	
LE09 ~15	-	None				0 ⁽²⁾	

*1) LU and LE Series: Apply grease directly to ball groove, etc. using a point nozzle.

*2) LS20, LS25, LH20: Use straight nozzle. (Point nozzle tip cannot be used because it interferes with the rail top surface.)

Figures of Grease Fittings

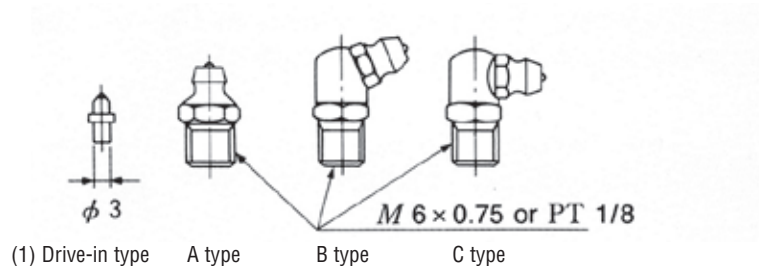

Application Sheet

Linear Guide – Rail Butting

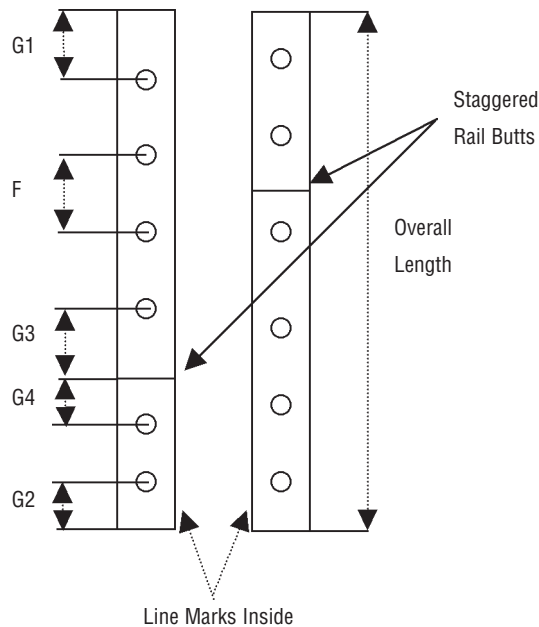

In order to determine rail butting configuration, please photocopy and complete this form from our catalogue and fax back to NSK. An electronic copy is available please contact our customer service.

Quantity: _____ Rail Number: _____

G1 Dimension: _____ mm G2 Dimension: _____ mm

Note 1: For butting rails only.

Note 2: Make sure line marks are inside for Rail Butting.

Consists of : _____ G1= _____ G3= _____

_____ G2= _____ G4= _____

Company: _____

Contact Name: _____

Telephone: _____ Fax: _____

Date: _____ E-Mail: _____

Remarks: _____

K1™ Maintenance-Free Lubrication Unit

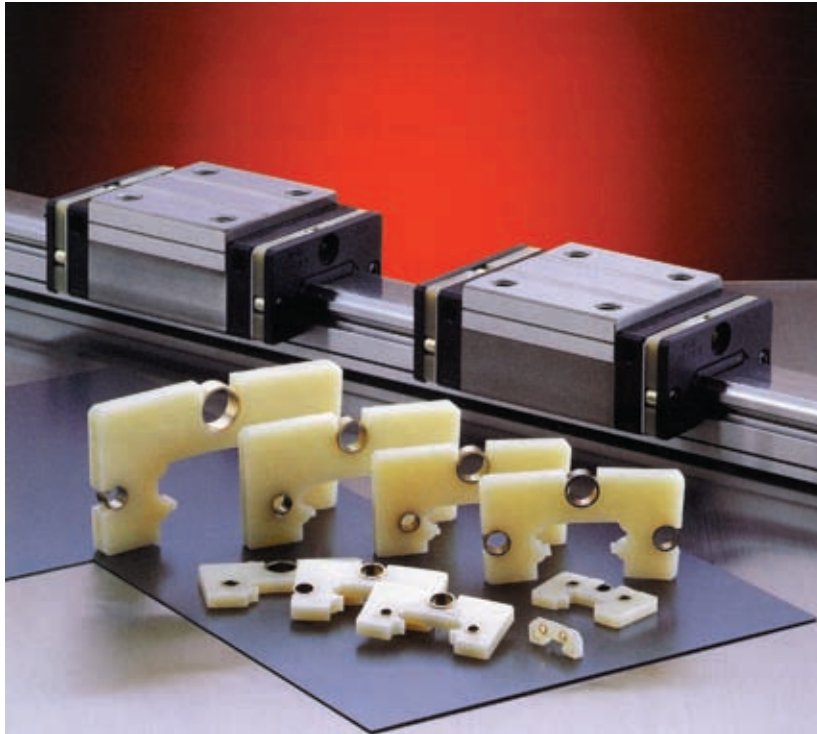

The NSK K1™ Lubrication Units distinctive capabilities as a compact and efficient oil-impregnated K1™ Lubrication Unit as well as a seal, greatly increases the performance of the Linear Guide. The K1™ Lubrication Unit is available in two types, one for industrial applications and one for food and medical devices where cleanliness and safety are paramount.

Features:

1. Long-term, maintenance-free usage.

In mechanical environments where lubrication is difficult to apply, long-term running efficiency is maintained by using the NSK K1™ Lubrication Units in combination with grease.

2. Prevention of oil-related environmental pollution.

In locations where oil greatly affects the environment, or in mechanisms with severe hygiene restrictions, sufficient lubrication is provided using the NSK K1™ Lubrication Unit in combination with grease.

3. Effective in environments where the lubricant is washed away.

In facilities where mechanisms are washed down with water, or subject to severe weather conditions, long service life is ensured by using the NSK K1™ Lubrication Unit in combination with grease. Especially effective under hygienic conditions where oil must not be dispersed.

4. Maintains efficiency in dusty environments.

In environments where oil and grease-absorbing dust is produced, long-term efficiency is maintained by using the NSK K1™ Lubrication Unit in combination with grease.

K1™ Lubrication Unit Identification Number

Refer to the following numbering system when ordering.

Example: LA H 30 AN Z - K1



Interchangeable Linear Guide Dimensions – LH, LS, LW, LU, LE Series Unit: mm

Interchangeable Ball Slide size code	Ball slide form			Standard Ball Slide length	Ball slide length with two NSK K1™ L	Thickness of NSK K1™ V ₁	Thickness of protective cover V ₂	Grease fitting projection N (mm)
	AN	EM	GM					
LAH15	AN	EM	GM	55 74	65.6 84.6	4.5	0.8	5
LAH20	AN BN	EM GM		69.8 91.8	80.4 102.4	4.5	0.8	14
LAH25	AN/AL BN/BL	EM GM		79 107	90.6 118.6	5.0	0.8	14
LAH30	AN/AL BN/BL	EM GM		85.6 98.6 124.6	97.6 110.6 136.6	5.0	1.0	14
LAH35	AN/AL BN/BL	EM GM		109 143	122 156	5.5	1.0	14
LAH45	AN BN	EM GM		139 171	154 186	6.5	1.0	15
LAH55	AN BN	EM GM		163 201	178 216	6.5	1.0	15
LAH65**	AN BN	EM GM		193 253	211 271	8.0	1.0	16
LAS15	AL CL	EL	FL KL	56.8 40.4	66.4 50	4.0	0.8	5
LAS20	AL CL	EL	FL KL	65.2 47.2	75.8 57.8	4.5	0.8	14
LAS25	AL CL	EL	FL KL	81.4 59.4	92 70	4.5	0.8	14
LAS30	AL CL	EL	FL KL	96.4 67.4	108.4 79.4	5.0	1.0	14
LAS35	AL CL	EL	FL KL	108 77	121 90	5.5	1.0	14
LAW17	EL			51.4	61.6	4.5	0.6	5
LAW21	EL			58.8	71.4	5.5	0.8	13
LAW27	EL			74	86.6	5.5	0.8	13
LAW35	EL			108	123	6.5	1.0	13
LAW50	EL			140.6	155.6	6.5	1.0	14
LAU09	AR	TR		30	36.4	2.7	0.5	–
LAU12	AR	TR		35.2	42.2	3.0	0.5	–
LAU15			AL	43.6	51.8	3.5	0.6	–
LAE09	AR	TR		39.8	46.8	3.0	0.5	–
LAE12	AR			45	53	3.5	0.5	–
LAE15	AR			56.6	66.2	4.0	0.8	–

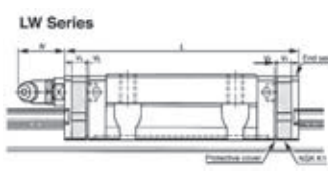
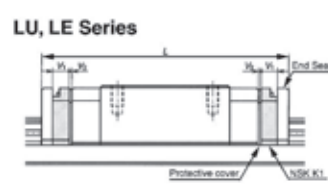
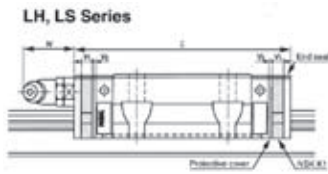

Note: For more bearing seal options see page 4.

* For Protector and Double Seal Information for LH Series please see page 13.
 * For Protector and Double Seal Information for LS Series please see page 21.

K1™ Lubrication Unit Handling and Assembly Instructions

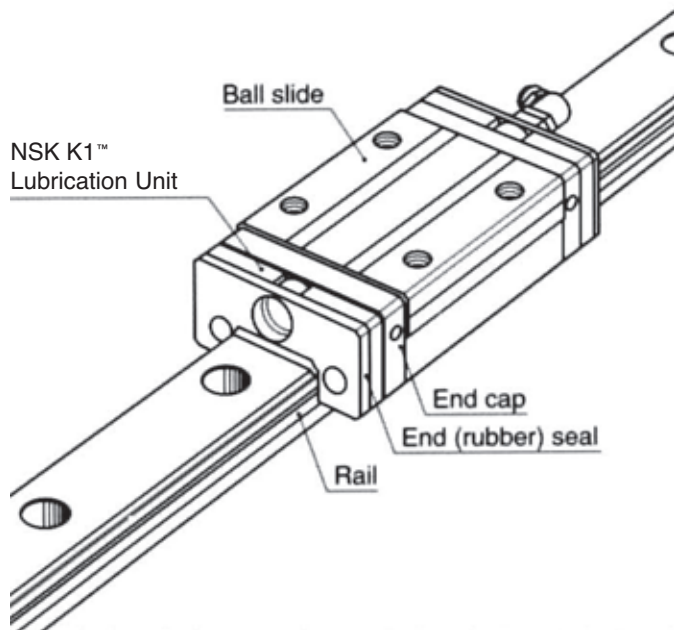

Handling Instructions

To maintain the NSK K1™ Lubrication Unit Seal's high efficiency over a long period of time, please follow these instructions.

1. Permissible temperature range

Max. operating temperature: 50°C (122°F)

Max. peak temperature: 80°C (176°F)

If not installed immediately, they should be kept refrigerated.

Avoid storage in direct sunlight.

2. Never leave the linear guide in close proximity to grease-removing organic solvents such as hexane, thinners, etc.

Never immerse the linear guide in kerosene or rust preventative oils which contain kerosene.

Note

Other oils such as: water-based cutting oil, oil-based cutting oil, grease (mineral oil-AS2, ester-PS2) present no problems to the K1™ Lubrication Units performance.

Assembly Instructions for the K1™ Lubrication Unit for Linear Guides

1. Slide linear bearing on to the linear rail, using the plastic provisional rail supplied.
2. Remove the grease fitting from the end of the bearing.
3. Remove the Phillips screws (2 pieces).
4. Remove the end seal from end of bearing.
5. Install threaded plug from K1™ Lubrication Unit kit (or see option 9 and 10 depending on application).
6. Install the cover plate from the K1™ Lubrication Unit kit, to the end of bearing, against the end cap.
7. Install K1™ Lubrication Unit without fixing rings, so it can be expanded over the rail.
8. Put the three (3) fixing rings in position on the K1™ Lubrication Unit.
9. Replace the end seal, in front of the K1™ Lubrication Unit.
10. Install connector screw for grease fitting.
11. Replace the grease fitting in connector screw.
12. Install the **extension** Phillips screws (2 pieces, supplied with the K1™ Lubrication Unit seal kit).

Note* The K1™ Lubrication Unit has a shelf life. They should be installed immediately upon receipt. It is important to avoid direct sunlight and extreme heat conditions.

Unit Conversions

To Convert

From	To	Multiply By
daN	N	10.000
kgf	N	9.81
kgf	lbf	2.205
kgf.cm	lbf.in	0.868
kgf.cm	ozf.in	13.890
kgf.m	lbf.ft	7.234
kgf.m	lbf.in	86.811
N.m	lbf.ft	0.738
mm	inch	0.03937
inch	mm	25.4

For more info
www.npa.nsk.com



Worldwide Sales Offices

NSK Ltd.—Headquarters, Tokyo, Japan	www.nsk.com		
Americas & Europe Department	tel: 03-3779-7120		
Asia Marketing & Sales Department	tel: 03-3779-7121		
Africa			
South Africa:			
NSK South Africa (Pty) Ltd.		tel: (011) 458 3600	
Johannesburg			
Asia and Oceania			
Australia:	www.nskaustralia.com.au		
NSK Australia Pty. Ltd.		tel: (03) 9764-8302	
Melbourne			
China:			
NSK Hong Kong Ltd.			
Hong Kong		tel: 2739-9933	
Kunshan NSK Co., Ltd.		tel: 0520-7305654	
Kunshan			
Guizhou HS NSK Bearings Co., Ltd.		tel: 0853-3521505	
Anshun			
NSK (Shanghai) Trading Co., Ltd.		tel: 021-62099051	
Shanghai			
NSK representative office			
Beijing		tel: 010-6590-8161	
NSK representative office			
Shanghai		tel: 21-6209-9051	
NSK representative office			
Guangzhou		tel: 020-8732-0583	
NSK representative office			
Anshun		tel: 0853-3522522	
India:			
Rane NASTECH Ltd.			
Chennai	tel: 04114-65313, 65314, 65365, 66002		
NSK representative office			
Chennai		tel: 044-4334732	
Indonesia:			
P.T. NSK Bearings Manufacturing Indonesia			
Jakarta		tel: 021-898-0155	
Korea:			
NSK Korea Co., Ltd.			
Seoul		tel: 02-3287-0300	
NSK Korea Co., Ltd., Changwon Plant			
Changwon		tel: 0551-287-6001	
Malaysia:			
NSK Bearings (Malaysia) Sdn. Bhd.			
Kuala Lumpur		tel: 03-7958-4396	
NSK Micro Precision (M) Sdn. Bhd.			
Kuala Lumpur		tel: 03-961-6288	
New Zealand:	www.nsk-rhp.co.nz		
NSK New Zealand Ltd.			
Auckland		tel: (09) 276-4992	
Philippines:			
NSK representative office			
Manila		tel: 02-759-6246	
Singapore:			
NSK International (Singapore) Pte Ltd.			
Singapore		tel: (65) 273 0357	
NSK Singapore (Pte) Ltd.			
Singapore		tel: (65) 278 1711	
Taiwan:			
Taiwan NSK Precision Co., Ltd.			
Taipei		tel: 02-2591-0656	
Thailand:			
NSK Bearings (Thailand) Co., Ltd.			
Bangkok		tel: 02-6412150-58	
NSK Safety Technology (Thailand) Co., Ltd.			
Chonburi		tel: (038) 214-317-8	
Siam NASTECH Co., Ltd.			
Chachoengsao		tel: (038) 522-343-350	
Europe			
NSK Europe Ltd.			
(European Headquarters)	www.eu.nsk.com		
Maidenhead, England		tel: 0162-850-9800	
France:			
NSK France S.A.			
Paris		tel: 01 30 57 39 39	
Germany:			
NSK Deutschland GmbH			
Düsseldorf		tel: 02102-481-0	
NSK Steering Systems Europe Ltd.			
Stuttgart		tel: 0771-79082-277	
Neueweg Fertigung GmbH			
Munderkingen		tel: 07393-540	
Italy:			
NSK Italia S.P.A.			
Milano		tel: 02-995-191	
Poland:			
NSK Europe Ltd. Warsaw Liaison Office			
Warsaw		tel: 48-22-645-1525, 1526	
NSK Iskra S.A.			
Kielce		tel: 48-41-366-6111	
Spain:			
NSK Spain S.A.			
Barcelona		tel: 93-575-4041	
Turkey:			
NSK Bearings Middle East Trading Co., Ltd.			
Istanbul		tel: 90-216-442-7106	
United Kingdom:			
NSK Bearings Europe Ltd.			
Peterlee, England		tel: 0191-586-6111	
NSK UK Ltd.			
Newark, England		tel: 0163-660-5123	
NSK Steering Systems Europe Ltd.			
Coventry, England		tel: 024-76-588588	
North and South America			
NSK Americas, Inc. (American Headquarters)			
Ann Arbor, Michigan, U.S.A.		tel: 734-913-7500	
Argentina:			
NSK Argentina SRL			
Buenos Aires		tel: 011-4762-6556	
Brazil:			
NSK Brasil Ltda.			
São Paulo		tel: 011-3269-4700	
Canada:			
NSK Canada Inc.			
Toronto		tel: 905-890-0740	
Mexico:			
NSK Rodamientos Mexicana, S.A. de C.V.			
Mexico City		tel: 5-301-2741	
United States of America:			
www.us.nsk.com			
NSK Corporation			
Ann Arbor, Michigan		tel: 734-913-7500	
Sales Offices:			
Ann Arbor, Michigan		tel: 734-913-7500	
Santa Fe Springs, California		tel: 562-968-1000	
NSK American Technical Center			
Ann Arbor, Michigan		tel: 734-913-7500	
NSK Precision America, Inc.			
Franklin, Indiana		tel: 317-738-5038	
San Jose, California		tel: 408-944-9400	
www.npa.nsk.com			
NKS Steering Systems America			
Bennington, Vermont		tel: 802-442-5448	
NSK Latin America Inc.			
Miami, Florida		tel: (305) 477-0605	

NSK Ltd. has a basic policy not to export any products or technology designated as controlled items by export-related laws. When exporting the products in this brochure, the laws of the exporting country must be observed. Specifications are subject to change without notice and without any obligation on the part of the manufacturer. Every care has been taken to ensure the accuracy of the data contained in this brochure, but no liability can be accepted for any loss or damage suffered through errors or omissions. We will gratefully acknowledge any additions or corrections.