

Standard Spindles Precision Grinding Spindles Cartridge Spindles Precision Boring Heads Live Centers

Standard Spindles	1
Precision Grinding Spindles.	3
Cartridge Spindles	7
Precision Boring Heads	13
Live Centers	15
Other Spindles	18



Standard Spindles

The technology of the machine tool is ever-progressing and the requirements of standard spindles are increasing steadily. NSK takes account of such technical requirements and is endeavoring to make standard spindles that are highly precise, highly rigid and highly functional. We are confident that NSK standard spindles will satisfy your needs.

- Cartridge system, easy to mount and exchange.
- Strict quality control to ensure high precision, high rigidity.
- All products in this catalog are available for prompt delivery.



PRECISION GRINDING SPINDLES

Features

- (1) As two sets of tandem duplex bearings are used with constant pressure preload, the preload is always constant.
- (2) The most productive spindle, producing good surface finish with high-precision, high-performance grinding.

Contents

Precision grinding spindle types, features and selection criteria	3
SA type (quill type) dimension table	4
SC type (external and surface) dimension table	4, 5
SF type (surface) dimension table	5
Exchangeable grinding wheel arbor <reference dimensions>	6

CARTRIDGE SPINDLES

Features

- (1) Because they are cartridge spindles, mounting to brackets and replacement are easy.
- (2) As the cartridge spindle for machining centers incorporates the entire set of spindle bore components, it is convenient for ATC.
- (3) Highly precise and rigid main spindle for NC lathes are also available.

Contents

Types of cartridge spindles	7, 8
Specifications and dimension table of cartridge spindles for machining centers	9, 10
Specifications and dimension table of E-40 economy type	11, 12
Specifications and dimension table of cartridge spindles for NC lathes	11, 12



PRECISION BORING HEADS

Features

Head replacement is easy, due to the standardization of the center height, mounting dimension in axial direction, distance from the front mounting bolt holes to the flange end face, and other dimensions.

Contents

Precision boring head types and features	13, 14
Dimension table for JSH****NW type	13, 14
Dimension table for SH****NW type	13, 14

LIVE CENTERS

Features

There is a wide variety in this series, to suit your specific needs, including a high-rigidity common type, high-precision high-rigidity type, light-load economical type, high-rigidity, semi-high-speed type, and high-precision high-rigidity, high-speed waterproof type.

Contents

Live center types, features and selection criteria	15
A (high-rigidity common type) dimension table	16
B (high-precision, high-rigidity type) dimension table	16
N (high-rigidity, semi-high-speed type) dimension table	16
J (light-load, economical type) dimension table	17
SW (high-precision, high-rigidity, high-speed waterproof type) dimension table	17
Other spindles	18

NSK Precision Grinding Spindles



Types and Features

- SA Type** Quill type spindle for various exchangeable wheel arbors. Can be used for a wide range of applications.
- SC Type** Two types are available, one for the flat belt-driven type for medium-size grinding wheels, and one for the V-belt-driven type for large-size grinding wheels.
- SF Type** For a cup-type grinding wheel, flat-belt driven. Incorporated precision bearings with high load capacity.
- Runout accuracy: less than 3 μm for all types with outside cylinder diameter of less than 70 mm. Less than 5 μm for all types with outside cylinder diameter of 70 mm or greater. (SA Type: Base of test bar. SC and SF Types: End of spindle shaft.)
 - Those for CCW rotation can be manufactured for special orders.

Selection Criteria

Type of grinding	Type	Suitable applications
Internal grinding	SA	Exchangeable grinding wheel arbor type. To grind different types of holes.
External grinding	SC	There are two types, one for medium-size grinding wheels and one for large-size grinding wheels.
Surface grinding	SC	To grind surfaces by using outside circumference of grinding wheel.
	SF	To grind surfaces by using the end face of a cup-type grinding wheel or dish-type grinding wheel.

Note: Please select the size suited to the mounting conditions.
Please select the spindle suited to the grinding conditions.

SA Type Internal Grinding Spindle (Exchangeable arbor-type grinding wheel)

- Grease lubrication
- Direction of rotation: Clockwise (viewed from pulley side)
- Runout accuracy: 3 μm or less (for outside spindle diameter: 70 mm or less)
5 μm or less (for outside spindle diameter: more than 70 mm)

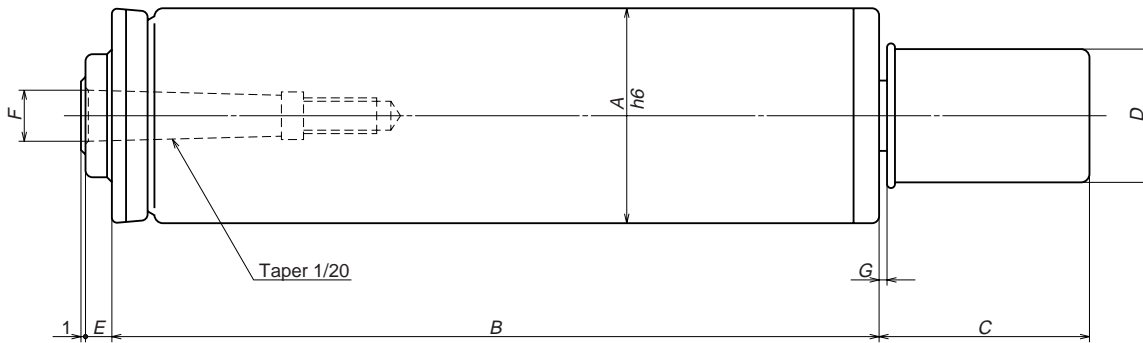

Unit: mm

Spindle reference No.	Max. rot. speed (rpm)	A	B	C	D	E	F	G
SA500	40000	50	180	40	21	7	7.938	2
SA600	30000	60	220	48	28	8	11.113	3
SA700	20000	70	250	69	42	9	17.463	3
SA800	16000	80	280	73	56	9	20.638	3
SA900	13500	90	320	84	63	9	23.813	4

SC Type External and Surface Grinding Spindle (Medium-size grinding wheel)

- Grease lubrication
- Direction of rotation: Clockwise (viewed from pulley side)
- Runout accuracy: 3 μm or less (for outside spindle diameter: 70 mm or less)
5 μm or less (for outside spindle diameter: more than 70 mm)

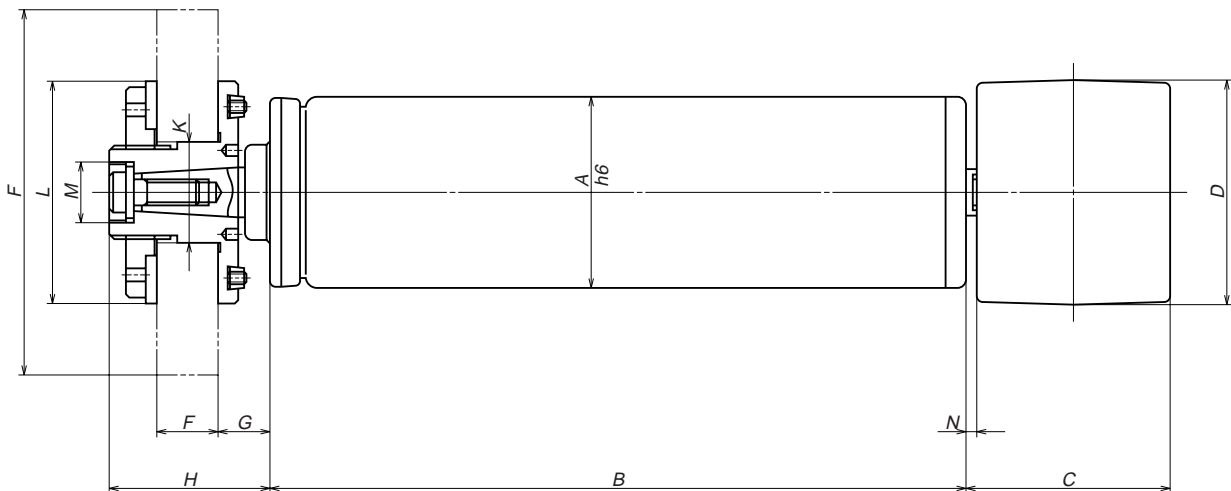

Unit: mm

Spindle reference No.	Max. rot. speed (rpm)	A	B	C	D	E	F	G	H	K	L	M	N
SC5500	6400	50	180	47	56	65 – 90	9.5 – 13	15.5	41	22.23	50	M14 × 1.5	2
SC6500	5000	60	220	63	70	75 – 115	13 – 19	17	51	31.75	70	M20 × 1.5	3
SC7500	3800	70	250	73	90	100 – 150	16 – 25	24	70	38.1	90	M26 × 1.5	3
SC8500	3200	80	280	83	110	125 – 180	19 – 32	24	80	63.5	115	M30 × 1.5	3

NSK Precision Grinding Spindles

SC Type External and Surface Grinding Spindle

(Large-size grinding wheel)

- Grease lubrication
- Direction of rotation: Clockwise (viewed from pulley side)
- Runout accuracy: 3 μm or less (for outside spindle diameter: 70 mm or less)
5 μm or less (for outside spindle diameter: more than 70 mm)
- Whetstone mount of SC5501 and SC6501 is the same as SC type (for medium-size whetstone).

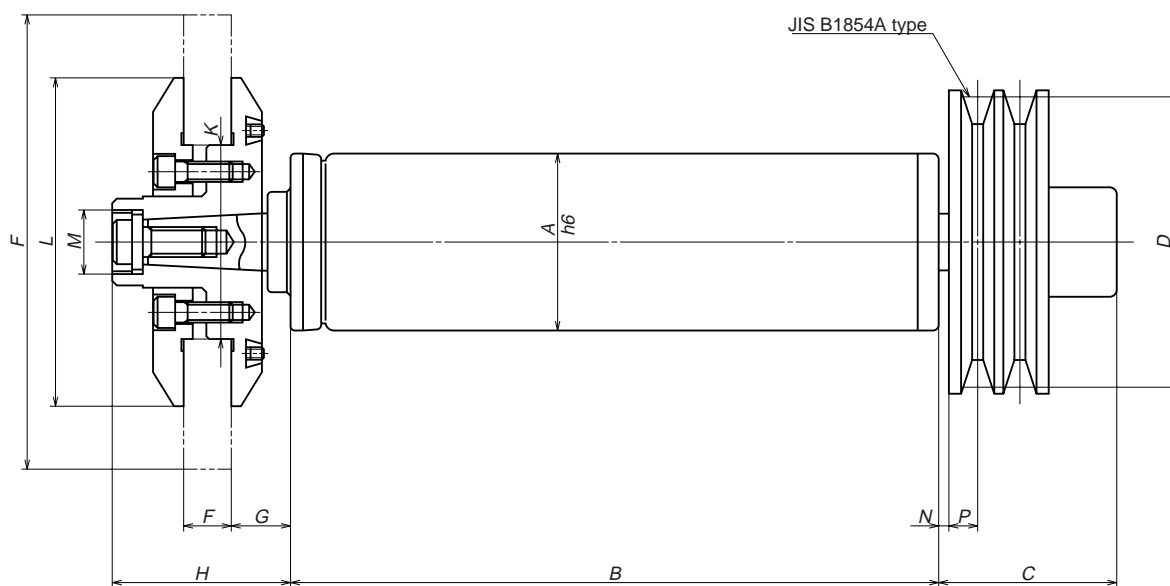

Unit: mm

Spindle reference No.	Max. rot. speed (rpm)	A	B	C	D	E	F	G	H	K	L	M	N	P
SC5501	5700	50	180	47	60	65 – 100	9.5 – 13	15.5	41	22.23	50	M14 × 1.5	2	10
SC6501	4600	60	220	48	80	75 – 125	13 – 19	17	51	31.75	70	M20 × 1.5	3	10
SC7501	3200	70	250	69	110	150 – 180	16 – 19	24	70	76.2	130	M26 × 1.5	3	10.5
SC8501	2800	80	280	73	130	150 – 205	19 – 25	24	80	76.2	130	M30 × 1.5	3	10.5

SF Type Surface Grinding Spindle

- Grease lubrication
- Direction of rotation: Clockwise (viewed from pulley side)
- Runout accuracy: 3 μm or less (for outside spindle diameter: 70 mm or less)
5 μm or less (for outside spindle diameter: more than 70 mm)

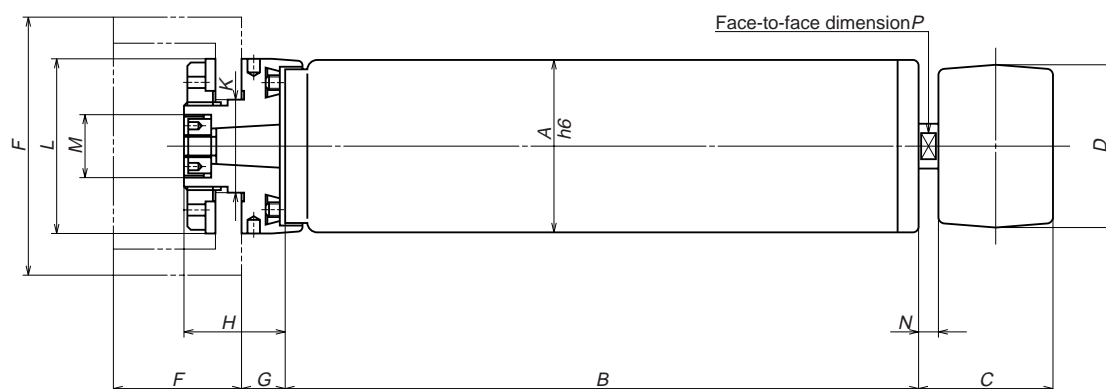

Unit: mm

Spindle reference No.	Max. rot. speed (rpm)	A	B	C	D	E max.	F	G	H	K	L	M	N	P
SF5500	7600	50	180	47	48	75	38	13	32	25.4	50	—	7	12
SF6500	6400	60	220	47	56	90	45	15	35	31.75	60	M22 × 1.5	7	12
SF7500	5700	70	250	64	63	100	50	15	39	38.1	70	—	9	19
SF8500	5000	80	280	64	70	115	50	15	39	38.1	80	—	9	23

Exchangeable Grinding Wheel Arbor

(Reference dimensions)

Note: If an exchangeable spindle for SA type is required, please manufacture one according to this figure.

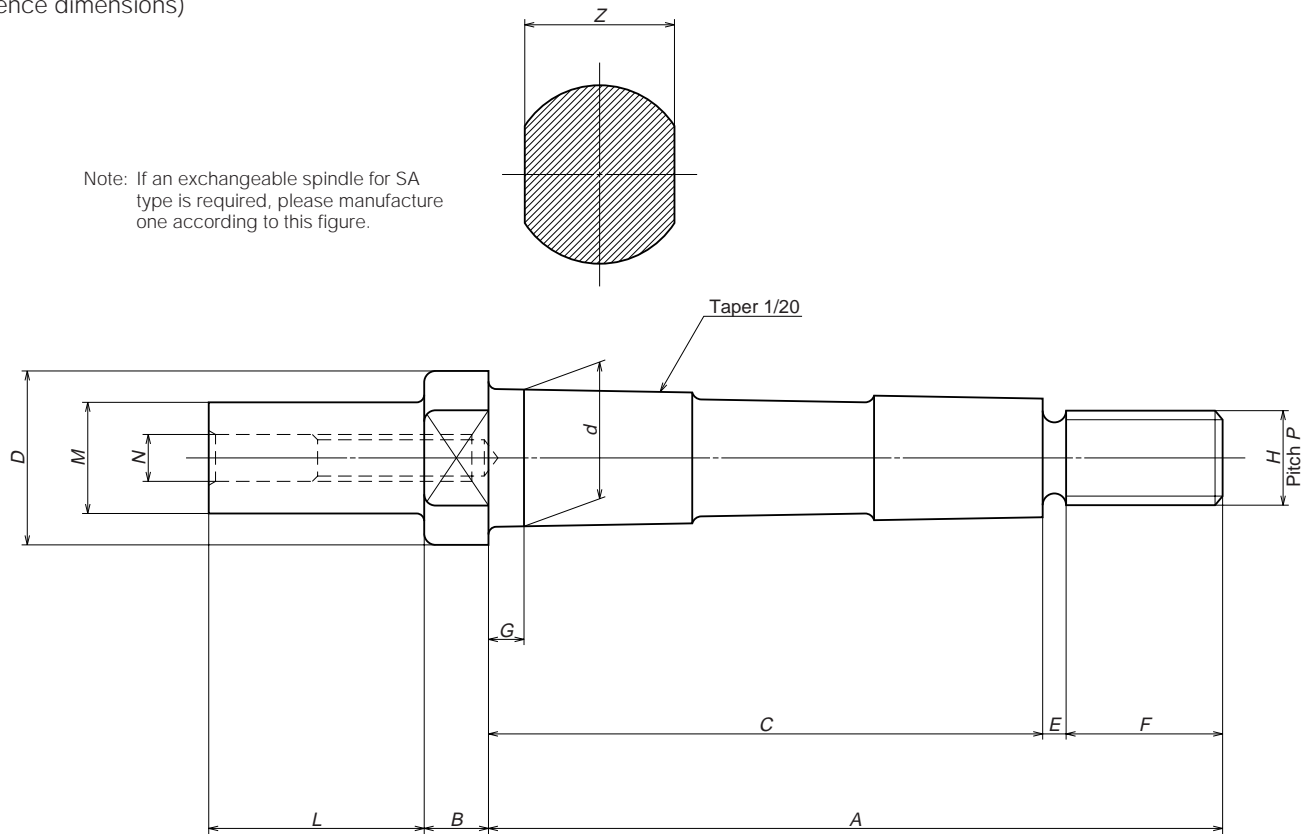

Unit: mm

Spindle reference No.	A	B	C	D	d	E	F	G	H	P	Z	M Recommended dimensions
SA500	49	5	37	11	7.938	2	10	3	6	1	9	5, 6, 8
SA600	66	6	50	14	11.113	3	13	3	8	1.25	12	5, 6, 8, 10, 12
SA700	94	8	71	22	17.463	3	20	4	12	1.75	19	5, 6, 8, 10, 12, 14, 16, 18
SA800	105	9	78	25	20.638	4	23	4	14	2	21	6, 8, 10, 12, 14, 16, 18, 21
SA900	118.5	11.5	86.5	30	23.813	6	26	4.5	16	2	26	10, 12, 14, 16, 18, 21, 24

Note: The maximum length L, with respect to the exchangeable, grinding wheel arbor neck with outside diameter M, can be referred to by using the table on the right.

Neck outside diameter M	5	6	8	10	12	14	16	18	21	24
Screw thread diameter N	3	3	3	4	6	6	6	8	8	8
Maximum length L	30	35	45	50	60	68	72	81	97	108

Speed of SC and SF Type

When motor speed is 3000 rpm, motor pulley diameter is $\phi 120$ and the maximum dimension of the grinding wheel (E) is used, the grinding speed becomes about 1800 m/min. If operating conditions deviate from these conditions, please determine the appropriate pulley diameter to obtain a grinding speed of 1800 m/min with the grinding wheel diameter used.

NSK Cartridge Spindles



High-rigidity G series
(G-40V, G-45V, G-50V)

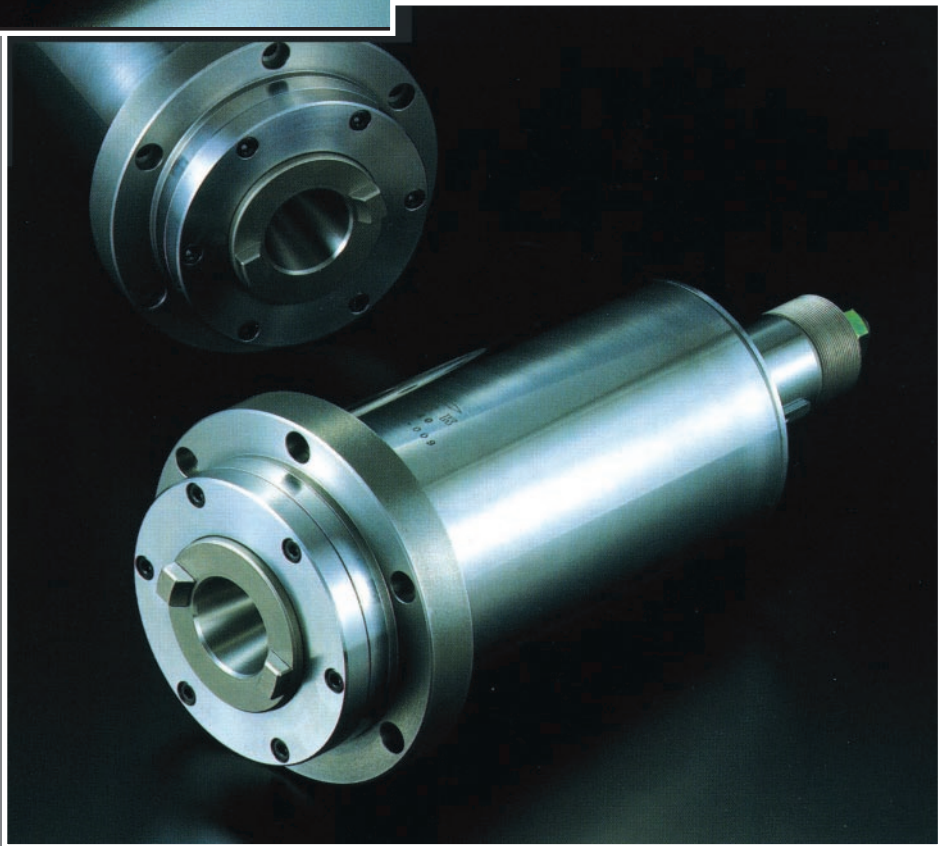

Economy type (E-40)

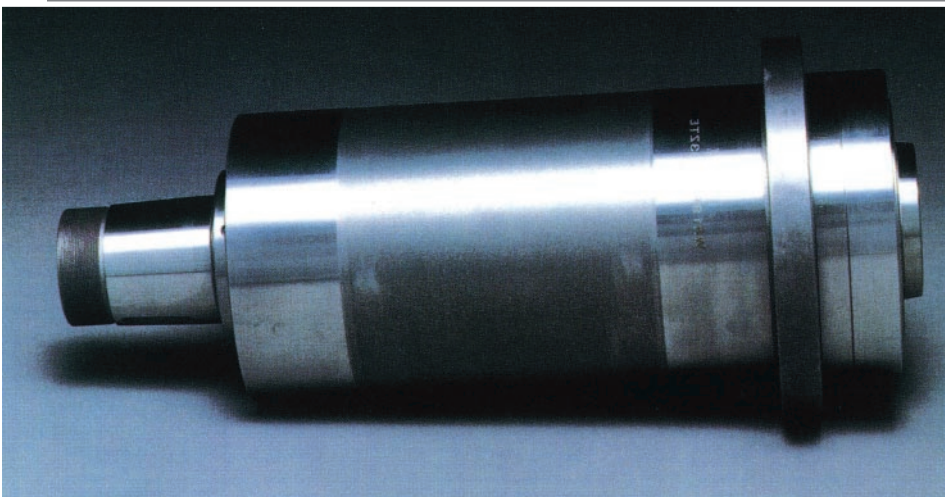

High-rigidity L series
(L-5, L-6)

Types and Features

For Machining Centers

■ High-rigidity G series (G-40V, G-45V, G-50V)

Greater radial rigidity is achieved with a double-row cylindrical roller bearing incorporated in the fixed side. The application of a high-speed angular contact ball bearing with a contact angle of 30° for thrust load provides axial rigidity with high-speed operation. The double-row cylindrical roller bearing integrated in the free side provides a large load capacity and ensures smooth axial movement against shaft elongation caused by rising temperatures.

■ High-speed H series (H-30V, H-40V)

A high-speed angular contact ball bearing with a contact angle of 15° is integrated in the fixed side. Although mainly used for high-speed operation, these bearings are also applicable to normal cutting at medium or low speeds since their quadruple configuration maintains rigidity. The free side incorporates a double-row cylindrical roller bearing, as in the high-rigidity series.

■ Economy type (E-40)

As a standard stock product, delivery is swift. Spindle functions required for cutting work are integrated in a compact body available at an unprecedented price. The high level of precision is suitable for a wide variety of fields, including automobiles, electrical appliances, machine tools, optical instruments, and metals. Furthermore, the cartridge bracket can be easily attached and detached. Tool clamps are built into the shaft, facilitating easy tool replacement.

- V-types are used for vertical installation, while H-types with drain holes are available for horizontal installation.
- Built-in tool clamps facilitate easier operation (suitable for ATC).
- Use MAS·BT as the tool holder.
- Use MAS·I as the pull stud.
- The outer casing is provided with a coolant groove.
- When cooling, adjust the coolant oil temperature to room temperature. (Flow is approximately 5 ℓ/min.)
- Insert an O ring between the unit and bracket before cooling the outer casing.
- General purpose tool holders (BT #40, pull stud MAS·I) can be used.
- The air seal cover type and V pulley are optionally available. *The air seal cover itself is not sold separately. The V pulley is an optional item sold separately; contact NSK for pre-installing a V pulley in the unit.
- Contact NSK for special products with custom-tailored specifications, such as high-speed rotating types and shaft-end modified types.

For NC Lathes

■ High-rigidity L series (L-5, L-6)

Greater radial rigidity is achieved with a double-row cylindrical roller bearing incorporated in the fixed side. A high-speed angular contact ball bearing with a contact angle of 30° for thrust load provides axial rigidity along with high-speed operation. The double-row cylindrical roller bearing integrated in the free side provides a large load capacity and ensures smooth axial movement against shaft elongation caused by rising temperatures.

- The shape of the shaft end on the mounting part conforms to JIS B6190 A2.
- V-pulley, synchronized pulley, parallel key, and drive button should be furnished by the customer.
- Runout accuracy: All types in this series feature mounting radial and axial runouts of 2 μm or less.
- All types in this series are used for horizontal installation and provided with drain holes.

For Machining Centers

G series (V type) cross section

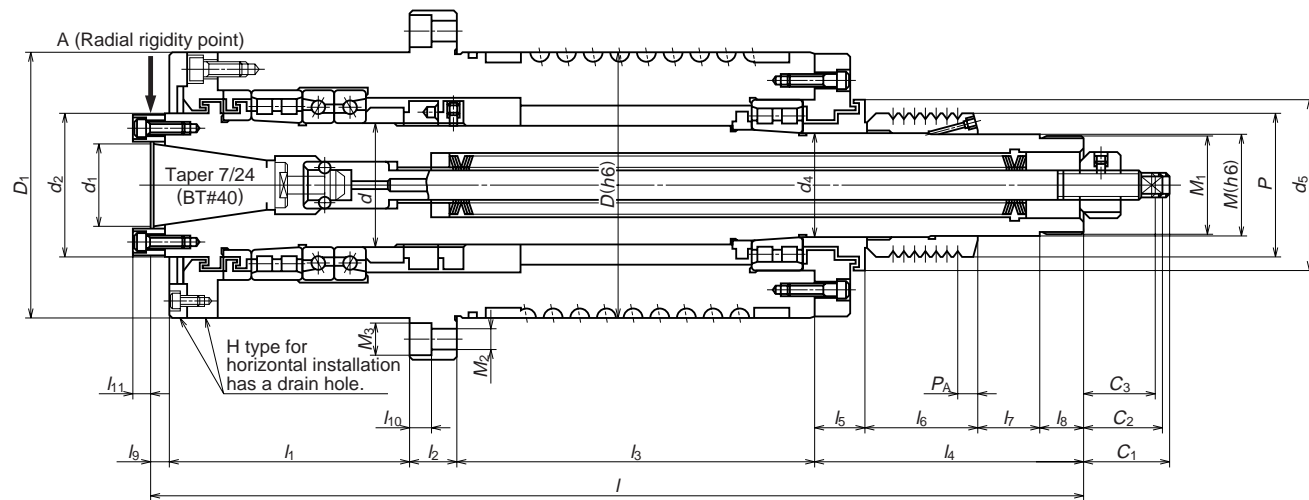

¥ M and M₁ sizes may vary at the time of manufacturing.
 ¥ When using M or M₁ parts, please request a detailed drawing to confirm size.

Cross section of H series (V type)

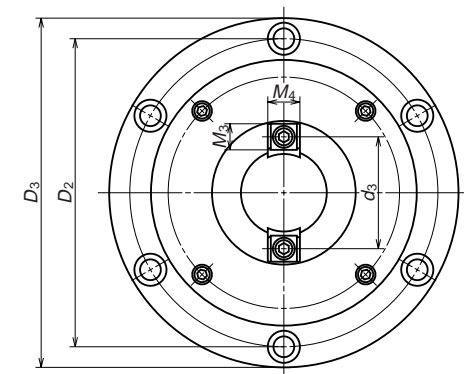
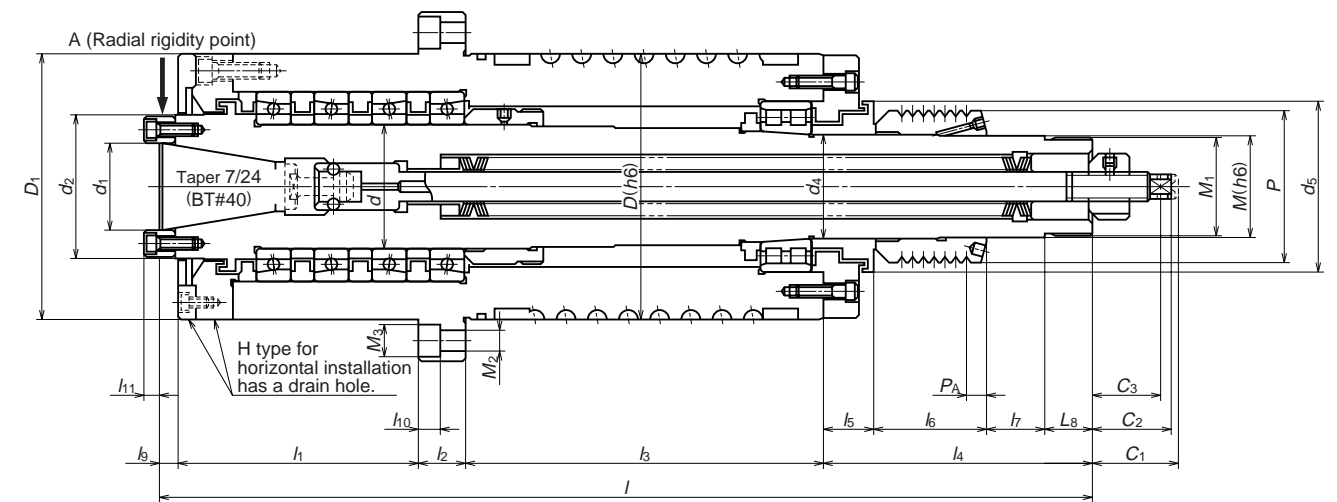

Side view
(common in G and H series)

High-Rigidity G Series

Type	Specification	National taper	Max. rot. speed (rpm)		Runout accuracy (μm) max.			Average power consumption (kW)	Pulley groove ^{Note 1}	Rigidity (kgf/μm) (reference)		Allowable static axial load (kgf)	Spindle weight (approx.) (kg)	Tool clamp power (kgf)	Tool un-clamp power (kgf)	Tool clamp type ^{Note 2}
			Rev. speed	$d_m \Pi$ max	Taper	Base of test bar	End of 300 test bar			Axial	Radial (point A)					
G-40V (H)		40	8000	0.62×10^6	2 m	3 m	8 m	5.5	5MS-7	28	25	2600	40	700	900	Ball chuck
G-45V (H)		45	6000	0.62×10^6				7.5	7MS-5	36	32	4200	60	900	1200	Collet chuck
G-50V (H)		50	4000	0.58×10^6				11	7MS-6	53	51	8200	140	1500	2700	Collet chuck

Type	Main dimensions (mm)														Main dimensions (mm)																		
	Shaft dia. d	NT Large d_1	d_2	d_3	d_4	d_5	C_1	C_2	C_3	Pulley		D	D_1	D_2	D_3	M	M_1	M_2	M_3	M_4	M_5	l	l_1	l_2	l_3	l_4	l_5	l_6	l_7	l_8	l_9	l_{10}	l_{11}
										P	P_A																						
G-40V (H)	65	44.5	76	60	55	90	44	40	35.4	76	10.5	140	140	162	185	50	M50 × 1.5	11	17.5	15.9	14	480	124	24	184	138	27	57	31	23	10	11	8
G-45V (H)	80	57.15	100	78	70	102	45	41	33	95	13.5	165	165	187	210	65	M65 × 1.5	11	17.5	19	18	525	128	25	204	153	26	62	36	29	15	11	9.5
G-50V (H)	110	69.85	130	98	100	137	48	43	34	130	12.5	220	220	250	280	95	M95 × 2.0	16	23	25.4	26	700	152	35	270	225	33	75	87	30	18	15.2	12.5

Note 1: Pulley groove form refers to banflescrum specifications of Bando Chemical Industries, Ltd.

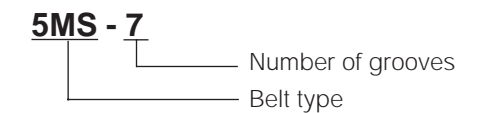

Note 2: Tool clamp: Ball chuck
 (National Taper #40 or less)
 Collet chuck
 (National Taper more than #40)
 (Collet: Made by BERG Inc.)

High-Speed H Series

Type	Specification	National taper	Max. rot. speed (rpm)		Runout accuracy (μm) max.			Average power consumption (kW)	Pulley groove ^{Note 1}	Rigidity (kgf/μm) (reference)		Allowable static axial load (kgf)	Spindle weight (approx.) (kg)	Tool clamp power (kgf)	Tool un-clamp power (kgf)	Tool clamp type ^{Note 2}
			Rev. speed	$d_m \Pi$ max	Taper	Base of test bar	End of 300 test bar			Axial	Radial (point A)					
H-30V (H)		30	12000	0.78×10^6	2 m	3 m	8 m	3.75	5MS-4	13	10	1000	28	400	520	Ball chuck
H-40V (H)		40	10000	0.82×10^6				5.5	5MS-7	17	14	1300	40	700	900	Ball chuck

Type	Main dimensions (mm)														Main dimensions (mm)																		
	Shaft dia. d	NT Large d_1	d_2	d_3	d_4	d_5	C_1	C_2	C_3	Pulley		D	D_1	D_2	D_3	M	M_1	M_2	M_3	M_4	M_5	l	l_1	l_2	l_3	l_4	l_5	l_6	l_7	l_8	l_9	l_{10}	l_{11}
										P	P_A																						
H-30V (H)	50	31.75	57	44	45	74	34.5	32.5	27.5	64	11.5	120	120	140	160	43	M42 × 1.5	8.8	14	15.9	11	390	111	20	146	106	25	41	22	18	7	8.6	8
H-40V (H)	65	44.45	76	60	55	90	44	40	35.4	76	10.5	140	140	162	185	50	M50 × 1.5	11	17.5	15.9	14	480	124	24	184	138	27	57	31	23	10	11	8

Economy Type (E-40)

Option

1. With air seal cover

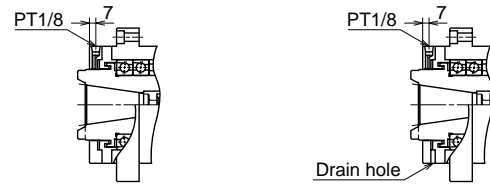

For vertical installation
(Reference No.: E-40/C1)

For horizontal installation
(Reference No.: E-40/C2)

2. V pulley
(Reference No.: KP-E4)

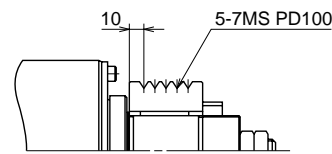

Note: The air seal cover itself is not sold separately. The V pulley is an optional item sold separately; contact NSK for pre-installing V pulley in the unit.

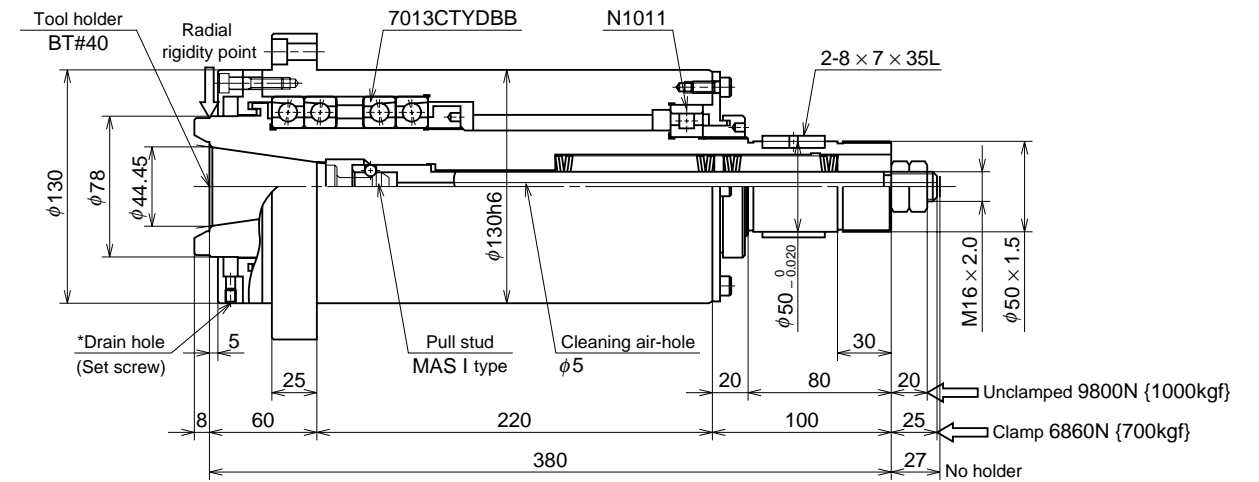
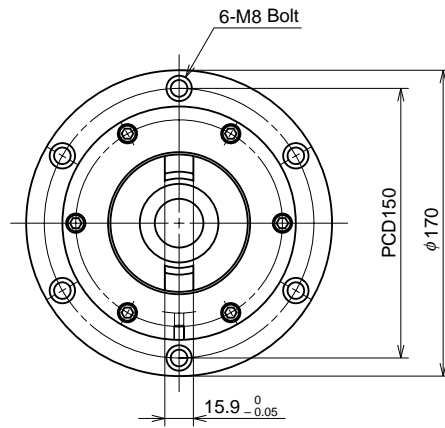

Unit: mm

Orientation	Rotation speed	Direction of rotation	Lubrication	Mass	Runout accuracy		Bearing used		Clamped power	Unclamped power
					At base of test bar	At a point 300 mm away from base	Taper side	Driving side		
Horizontal, vertical (driving end up)	Maximum 5000 rpm	Both directions	Grease	25 kg	0.003 mm or less	0.010 mm or less	7013CTYDBB	N1011	6860N (700 kgf)	9800N (1000 kgf)

Note: Custom products can be manufactured based on this spindle. For specially design products, including ones with high-speed rotation specifications, varied spindle end forms, etc., please contact NSK.

For NC Lathes

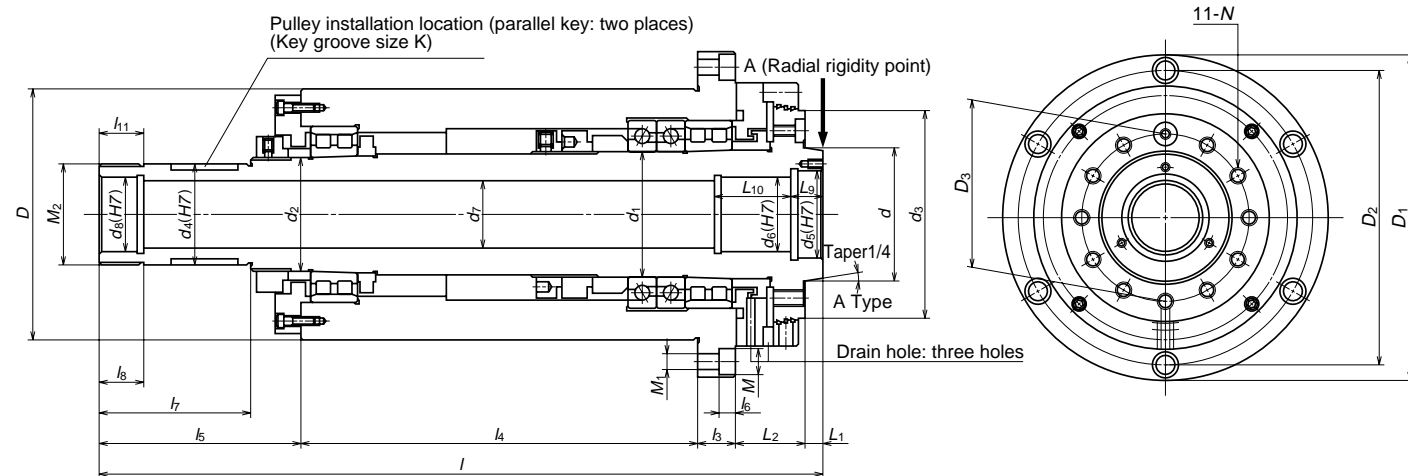

Specifications	Shaft-end specification (JIS)	Rotation speed		Rigidity (kgf/mm) (reference)		Allowable static axial load (kgf)	Spindle weight (approx.)(kg)	Allowable static axial load (kgf)
		Max. rot. speed (rpm)	$d_m \Pi$ max	Axial	Radial (point A)			
L-5	A2-5	5000	0.51×106	36	34	4200	60	5.5
L-6	A2-6	4000	0.5×106	46	55	6300	80	7.5

Unit: mm

Type	D	D ₁	D ₂	D ₃	M	M ₁	M ₂	N	d	d ₁	d ₂	d ₃	d ₄	d ₅	d ₆	d ₇	d ₈	l	l ₁	l ₂	l ₃	l ₄	l ₅	l ₆	l ₇	l ₈	l ₉	l ₁₀	l ₁₁	K
L-5	170	220	195	104.8	20	14	M65 x 1.5	M10, 22 depth	82.563	80	70	133	65	55	50	42	45	503	13	48	26	283	133	13	100	34	25	55	35	12 x 5 x 50 l
L-6	200	260	235	133.4	20	14	M80 x 1.5	M12, 25 depth	106.375	100	90	165	80	70	60	54	60	574	14	55	30	315	160	13	120	35	25	60	35	12 x 5 x 53 l

NSK Precision Boring Spindles



Types and Features

SH1000NW (SH1045NW, SH1060NW, SH1080NW) Type [Most suited to light-load, high-speed cutting]

This type uses 4 ultra-precise angular contact ball bearings of different sizes. All bearings are spring-preloaded, arranged to automatically correct for thermal expansion and concordance of bearings while in use.

SH3000NW (SH3060NW, SH3080NW) Type [Most suited to low speed, heavy cutting]

This type uses two tapered roller bearings and one angular contact ball bearing. The preload of the tapered roller bearings is adjusted by the round nut mounted on the rear of the spindle. The angular contact ball bearing is spring preloaded, thus the main spindle shaft is supported at 3 points.

JSH 1000NW (JSH1045NW, JSH1060NW, JSH1080NW) Type [Most suited to light-load, high-speed cutting]

This type uses two sets each of ultra-precise, angular-contact ball bearings, the preload is adjusted by spacers inserted between bearings.

- Runout accuracy: The radial and axial runout for the boring bar mounting part is less than 3 μm for all types.
- All boring heads have waterproof labyrinth mechanisms but we recommend using the protective cover as shown in the figures on the right.
- Accessories: Bolt, nut and wrench for installation are attached to all products.

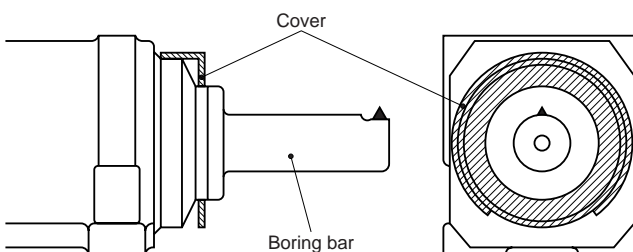
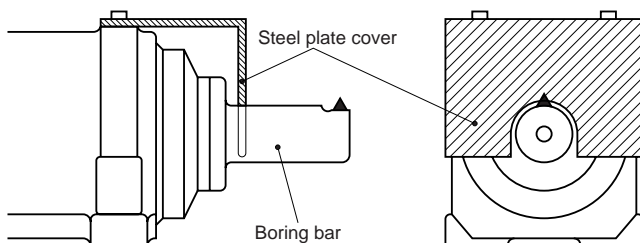
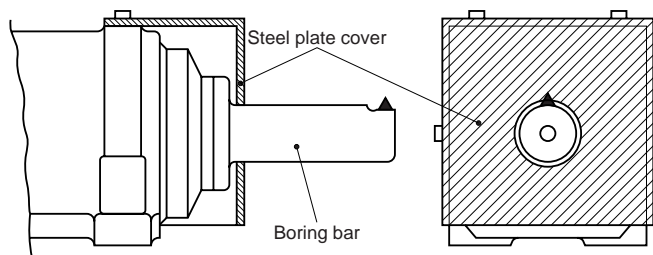
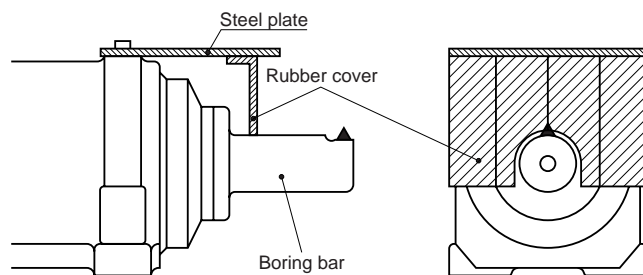

Unit: mm

Dimensions Boring head designation	Front bearing shaft diameter	Max. rot. speed (rpm)	A	B	C	D	E	F	G	H	J	K	L
JSH1045NW	45	8000	465	35	17	162	80	102	110	8	3 – M10 × 1.5 Tap 18 Depth	32	25
JSH1060NW	60	4000	475	40	22	187	80	102	150	20	3 – M10 × 1.5 Tap 18 Depth	43	40
JSH1080NW	80	3000	480	45	22	202	118	142	185	26	6 – M12 × 1.75 Tap 18 Depth	62	55

Unit: mm

Dimensions Boring head designation	Front bearing shaft diameter	Max. rot. speed (rpm)	A	B	D	E	F	G	J	K	L
SH1045NW	45	8000	465	8	9	160	102	110	3 – M10 × 1.5 Tap 18 Depth PCD80	36	20
SH1060NW	60	4000	475	18	9	195	102	150		45	25
SH3060NW	60	2000	475	18	9	195	102	150		45	25
SH1080NW	80	3000	480	21	9	210	142	185	6 – M12 × 1.5 Tap 18 Depth PCD118	50	30
SH3080NW	80	1500	480	21	9	210	142	185		50	30

JSH (NW) Type

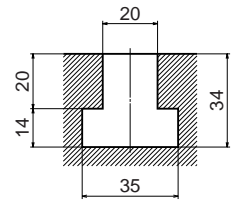
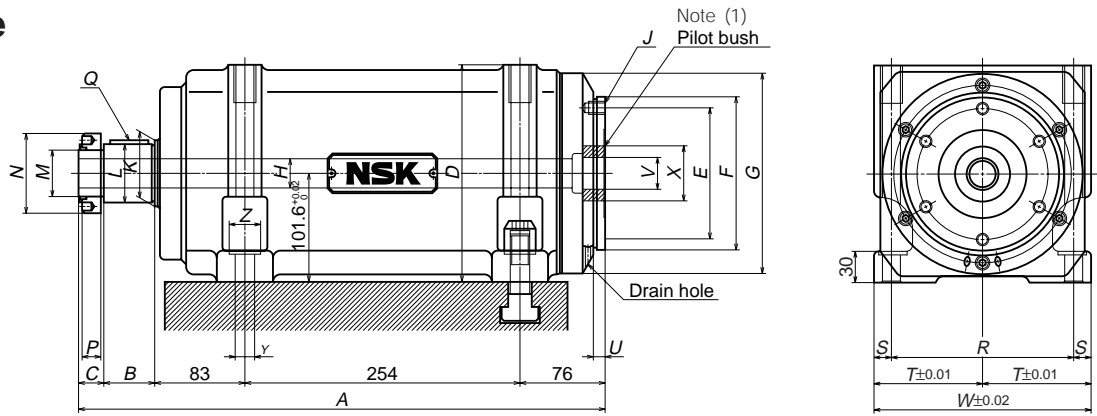

Groove form when attached bolt and nut specifications are applied (common in JSH and SH).

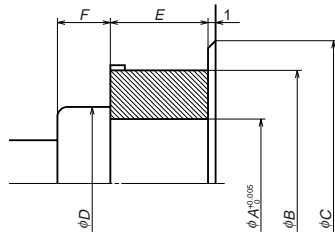

Pilot Bush Dimensions Table

Unit: mm

Boring head designation	Dimensions					
	A	B	C	D	E	F
JSH1045NW, SH1045NW	20	36	50	26	20	10
JSH1060 NW, SH3060NW SH1060NW	25	45	50	31	20	10
JSH1080NW, SH3080NW SH1080NW	30	50	85	36	25	10

SH (NW) Type

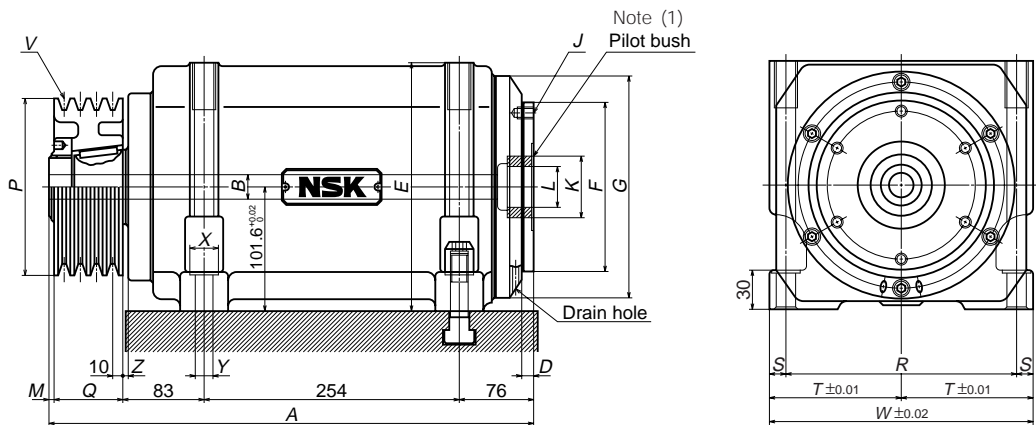

Unit: mm

M	N	P	Q	R	S	T	U	V	W	X	Y	Z	Boring head weight (approx.) (kg)
M16 × 1.5	40	14	Parallel key 5 × 5 × 25	108	14	68	9	20	136	36	16.5	25	43
M30 × 1.5	58	19	Parallel key 7 × 7 × 30	140	15	85	9	25	170	45	20	30	70
M45 × 1.5	74	19	Parallel key 10 × 8 × 35	165	17.5	100	9	30	200	50	20	30	100

Unit: mm

M	P	Q	R	S	T	V ⁽²⁾	W	X	Y	Z	Boring head weight (approx.) (kg)
17	80	35	96	12	60	JIS Type A 2 line	120	25	16.5	4	43
27	100	35	125	17.5	80	JIS Type A 2 line	160	30	20	4	70
12	120	50	125	17.5	80	JIS Type A 3 line	160	30	20	4	70
2	120	65	165	17.5	100	JIS Type A 4 line	200	30	20	5	100
2	150	65	165	17.5	100	JIS Type A 4 line	200	30	20	5	100

Note (1) For pilot bush parts, please refer to the pilot bush parts dimensions table on this page.

(2) The specification of the V-pulley groove is JIS B 1854 A type.



Selection Criteria

Type	Main specifications and features
LC-A	<ul style="list-style-type: none"> • Runout at the center conical part is less than 0.005 mm. • High rigidity, long life.
LC-B	<ul style="list-style-type: none"> • Runout at the center conical part is less than 0.0025 mm. • High precision, high rigidity, long life.
LC-N	<ul style="list-style-type: none"> • High-rigidity, semi-high-speed type, designed to buffer thermal expansion of the workpiece. • Employs needle-type roller bearings and thrust ball bearings.
LC-J	<ul style="list-style-type: none"> • Light load, economy type. The compact body has almost the same dimensions as dead center. • The center-cup rotating type employs needle-type roller bearings.
LC-SW	<ul style="list-style-type: none"> • Waterproof type with a contact seal structure. • High-precision, high-rigidity, high-speed type.

LC-A, -B Type

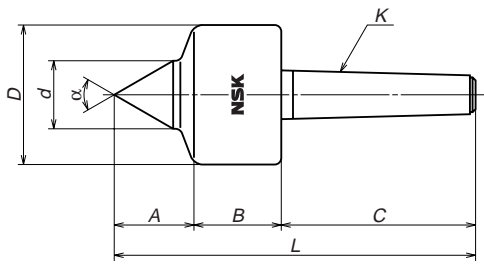

LC-2B

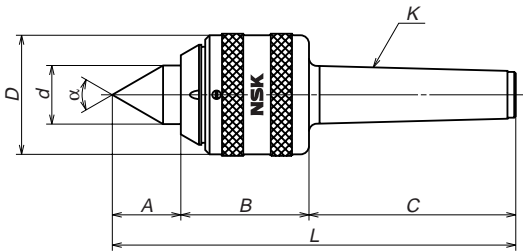

LC-3A, -B • LC-4A, -B

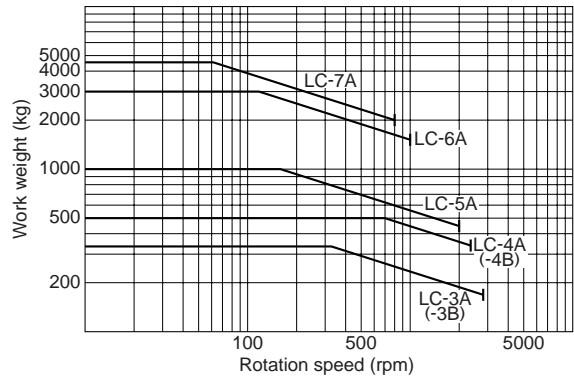

LC-A, -B type maximum work weight

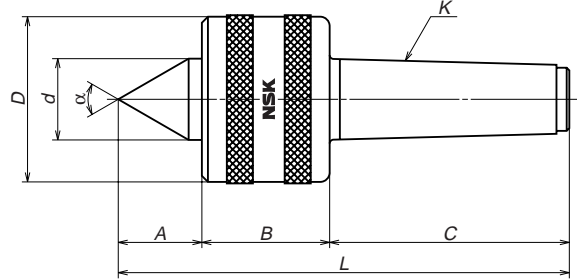

LC-5A • LC-6A • LC-7A

Unit: mm

Designation	K	D	d	A	B	C	L	α	Runout accuracy (μm) max.
LC-2B	Morse taper #2	50	25	30	30	68	128	60°	0.005
LC-3A LC-3B	Morse taper #3	51	24	28	53.5	85	166.5	60°	0.005 0.0025
LC-4A LC-4B	Morse taper #4	66	31	40	66	108	214	60°	0.005 0.0025
LC-5A	Morse taper #5	80	38	41	57	136	234	60°	0.005
LC-6A	Morse taper #6	132	64	65	100	189	354	60°	0.010
LC-7A	Morse taper #7	168	80	74	128	260	462	75°	0.010

LC-N Type

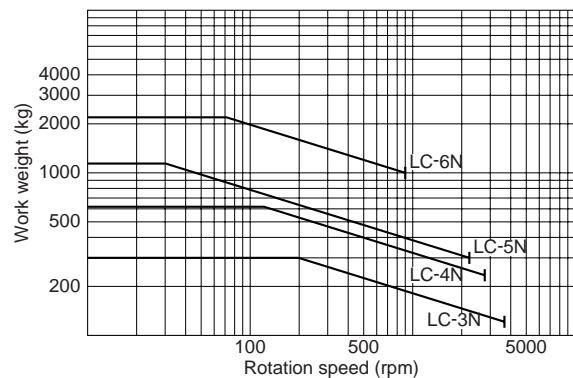
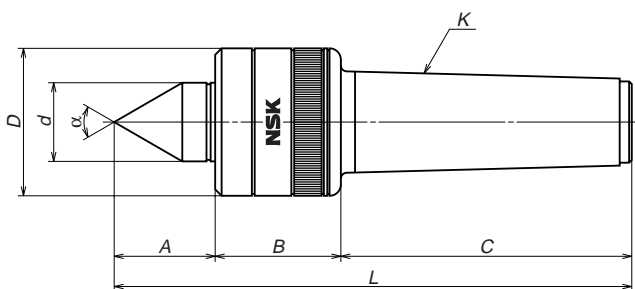

LC-N type maximum work weight

Unit: mm

Designation	K	D	d	A	B	C	L	α	Runout accuracy (μm) max.
LC-3N	Morse taper #3	46	22	35	46	85	166	60°	0.005
LC-4N	Morse taper #4	56	30	40	53	108	201	60°	0.005
LC-5N	Morse taper #5	65	35	45	55	136	236	60°	0.005
LC-6N	Morse taper #6	100	50	70	82	189	341	60°	0.007

NSK Live Centers

LC-J Type

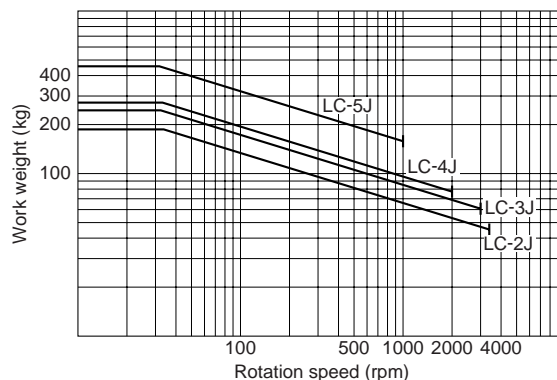
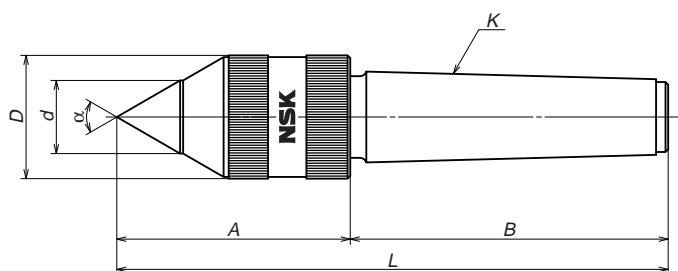

LC-J type maximum work weight

Unit: mm

Designation	<i>K</i>	<i>D</i>	<i>d</i>	<i>A</i>	<i>B</i>	<i>L</i>	α	Runout accuracy (μm) max.
LC-2J	Morse taper #2	28	15	58	68	126	60°	0.010
LC-3J	Morse taper #3	35	20	71	85	156	60°	0.010
LC-4J	Morse taper #4	42	25	78	108	186	60°	0.010
LC-5J	Morse taper #5	56	30	102	136	238	60°	0.010

LC-SW Type

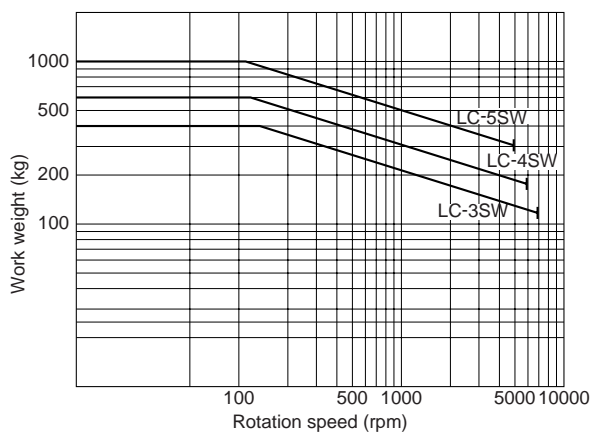
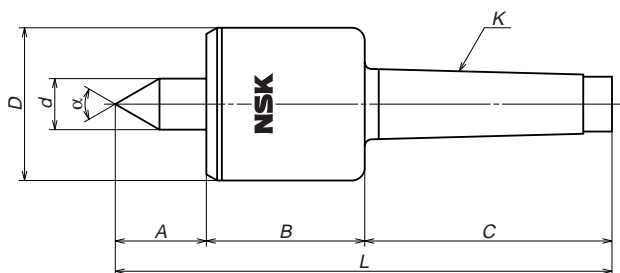

LC-SW type maximum work weight

Unit: mm

Designation	<i>K</i>	<i>D</i>	<i>d</i>	<i>A</i>	<i>B</i>	<i>C</i>	<i>L</i>	α	Runout accuracy (μm) max.
LC-3SW	Morse taper #3	54	18	33	55	85	173	60°	0.003
LC-4SW	Morse taper #4	71	30	43	67	108	218	60°	0.003
LC-5SW	Morse taper #5	79.5	36	50	70	136	256	60°	0.003

Note: The maximum work weight diagrams for all models show the allowable work weight for different speeds when estimated bearing life estimated at 3,000 hours; and the upper limit of low speed indicates the maximum allowable work weight.

Other Spindles

Specially Designed Spindles With an Introduction to Other NSK Spindles

Spindle with Built-in Motor

Motor: AC Servo Motor
(Attachment: AC spindle servo unit)
Use: Machining center
NC lathe
Lubrication: Grease, oil vapor
Option: Super-high-speed spindle
(Ceramic ball bearings specification)

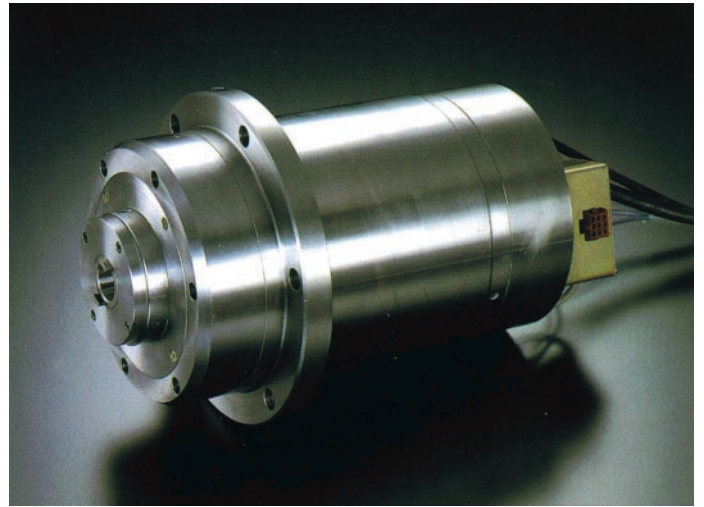

$\phi 45 \times 30000$ rpm (5.5/7.5 kW)

High-Frequency Spindle

Motor: High-frequency motor
Use: NC milling machine, NC router, internal grinding
Lubrication: Grease, oil mist, oil vapor
Option: High-frequency inverter



$\phi 20 \times 30000$ rpm (1.25 kW) $\phi 8 \times 180000$ rpm (0.35 kW)

High-Speed Air-Spindle

Motor: High-Frequency motor
Use: Slicing (Brittle material)
Dicing (Brittle material)
Option: High-frequency inverter
Air clean units



$\phi 42 \times 30000$ rpm (2.2 kW) $\phi 28 \times 40000$ rpm (0.8 kW)

In addition to standard spindles, the spindles mentioned above are specially designed and manufactured by NSK. Be sure to indicate specially designed spindles in your order.