

NSK

SNN SPLIT PLUMMER BLOCKS

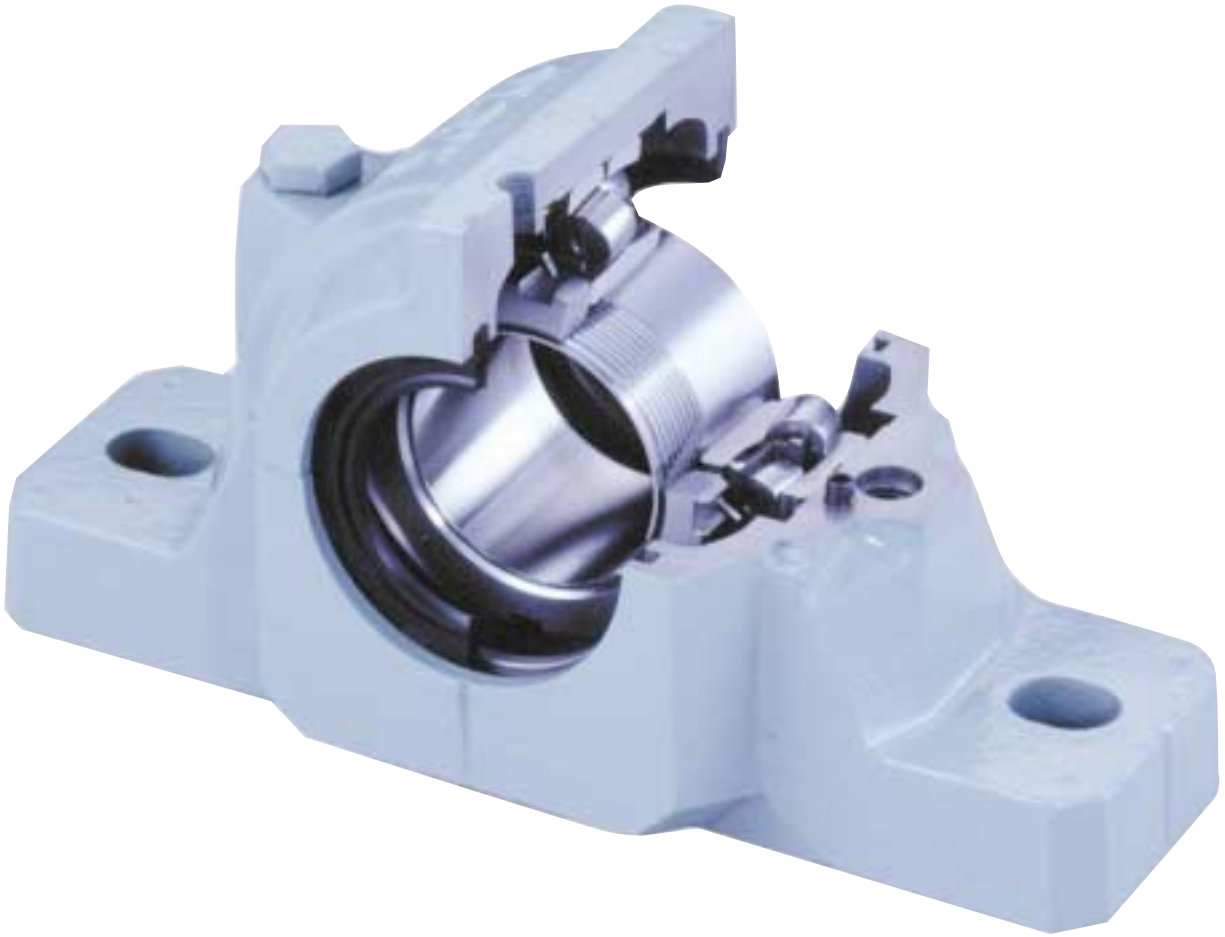

SNN SPLIT PLUMMER BLOCKS FROM NSK



The SNN split plummer block from NSK combines quality materials and design to maximize bearing performance. With features like serialized cap and base to prevent mixing of components, alignment aids, two and four-bolt mounting and multiple positioning of grease fittings, this housing replaces all others in the SN family. Additional features include:

Precision machined bearing seat • Web design for efficient heat transfer • Solid corners for locating pins • ISO grade 8.8 cap bolts • Square-shaped base with center marks for alignment • Designed for either grease or oil lubrication with a large oil reservoir

FEATURES AND BENEFITS

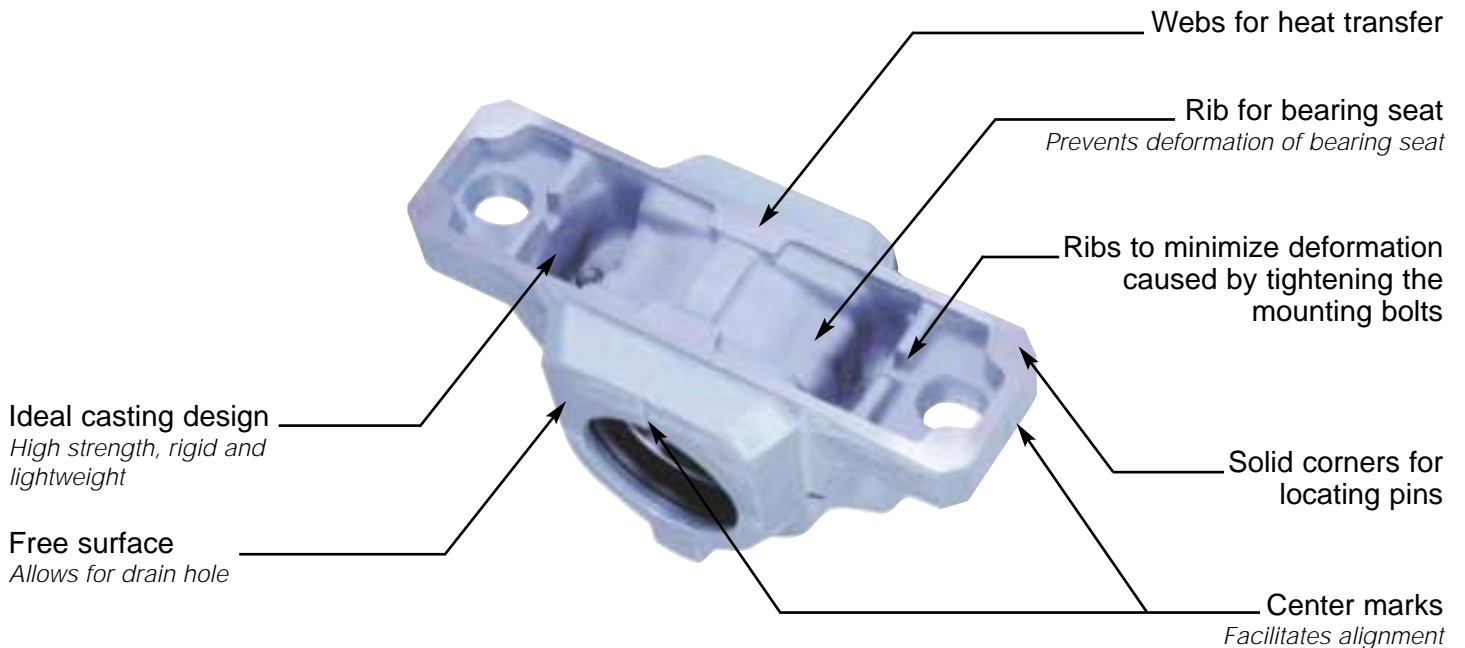
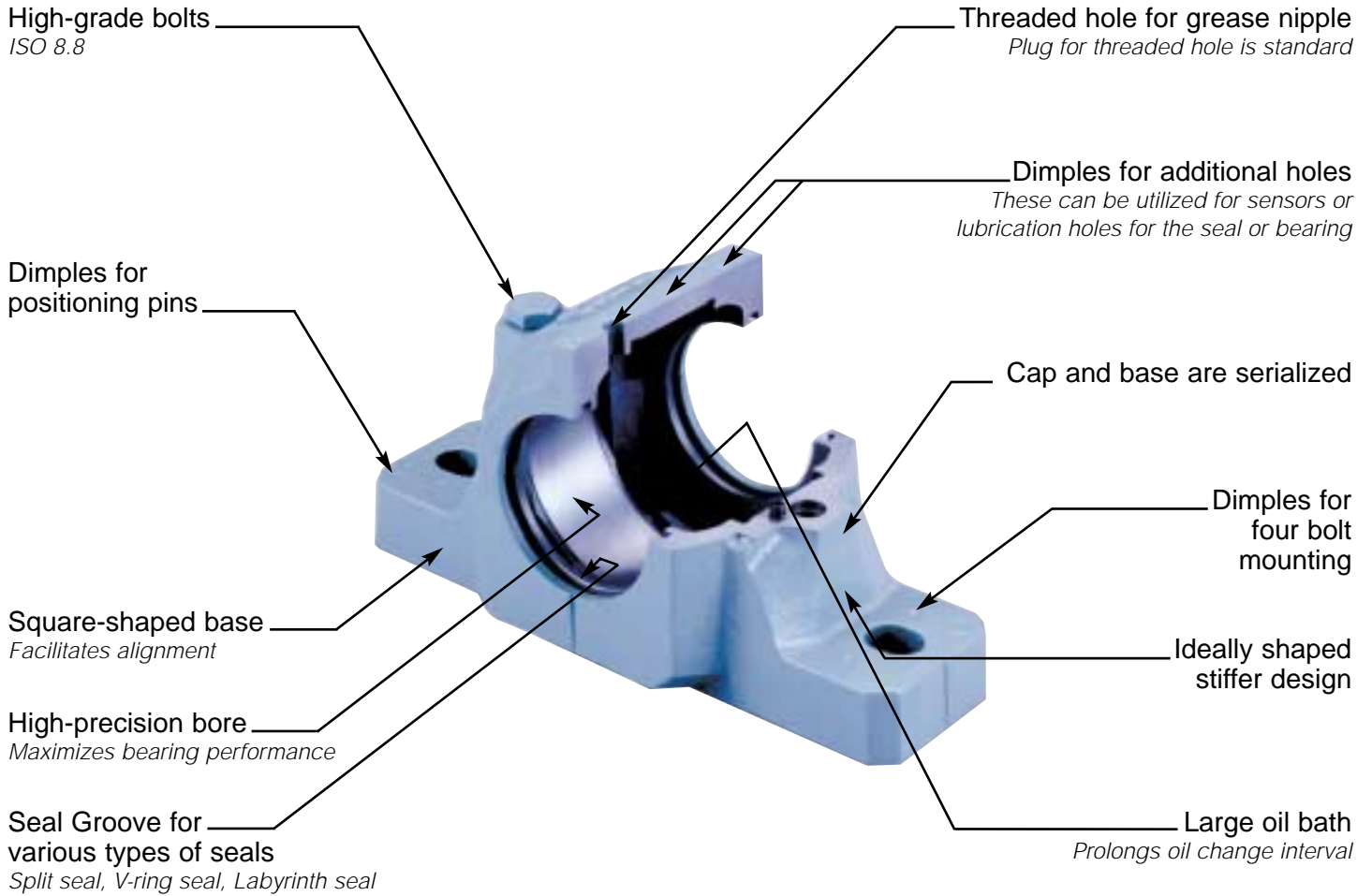

HOUSING NO.

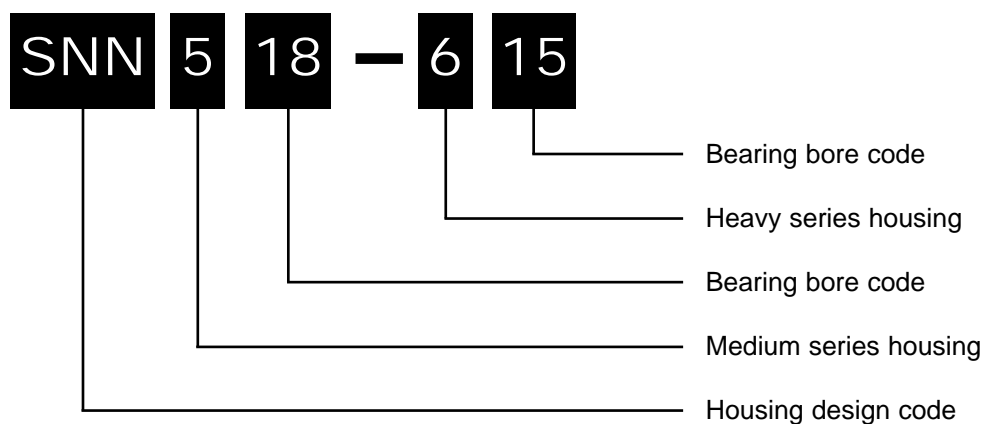

The SNN series comprises a number of housings which, when combined with different seal options and ball or spherical roller bearings, provides an answer for most plummer block applications with shaft diameters ranging from 3/4" to 5.1/2" (20mm to 140mm).

HOW TO ORDER

When ordering a complete assembly, you will receive the following components (e.g. SNN22517-2.15/16G):

- 1 - SNN517 housing
- 1 - G517 double-lip seal for a 2.15/16" shaft
- 1 - 22217EAKE4 spherical roller bearing
- 1 - HA317 adapter sleeve

If the assembly is to be fixed, add the letter 'X' to the assembly part number, e.g. SNN22517-2.15/16GX, you will receive 2 fixing rings SR150X12.5. You must specify the number of fixed assemblies at time of ordering. Note: only one assembly per shaft should be fixed.

If one side of the housing will be closed, add the letter 'Y' to the assembly part number, e.g. SNN22517-2.15/16GY. You will receive one end cover A517.

SEAL TYPES AND THEIR FEATURES

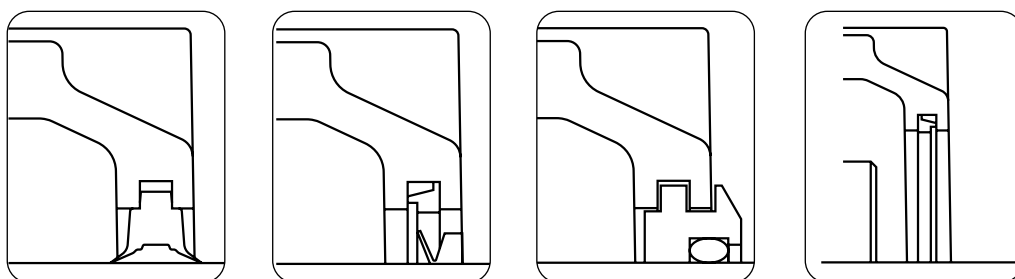

	CONTACT		NON-CONTACT	END COVER
	G-LOK SEAL	V-RING SEAL	TS-RING SEAL	A517
Max. speed	5 m/s	7 m/s		-
Grease Lubrication	Excellent	Excellent	Good	-
Oil Lubrication	Fair	Good	Excellent	-
Friction torque	Good	Good	Excellent	-
Temperature range	-20 thru +80°C	-20 thru +80°C	-20 thru +120°C	-20 thru +120°C
Performance	Dust	Excellent	Good	-
	Large particles	Good	Poor	-
	Water	Good	Good	-

CLEARANCE ADJUSTMENT FOR SPHERICAL ROLLER BEARINGS WITH TAPERED BORE

Table 1

Nominal Bore Dia.		Unmounted Clearance Tapered Bore						Reduction in Radial Clearance		Axial Movement ⁽¹⁾ Taper 1 : 12		Minimum Permissible Residual Clearance		
		CN		C3		C4								
over	incl	min	max	min	max	min	max	Min	Max	Min	Max	CN	C3	C4
mm		in		in		in		in		in		in		
24	30	0.0012	0.0016	0.0016	0.0022	0.0022	0.0030	0.0006	0.0008	0.0120	0.0140	0.0006	0.0008	0.0014
30	40	0.0014	0.0020	0.0020	0.0026	0.0026	0.0033	0.0010	0.0012	0.0158	0.0177	0.0004	0.0010	0.0014
40	50	0.0018	0.0024	0.0024	0.0032	0.0032	0.0039	0.0012	0.0014	0.0177	0.0217	0.0006	0.0012	0.0018
50	65	0.0022	0.0030	0.0030	0.0037	0.0037	0.0047	0.0012	0.0014	0.0177	0.0217	0.0010	0.0014	0.0024
65	80	0.0028	0.0037	0.0037	0.0047	0.0047	0.0059	0.0016	0.0018	0.0236	0.0276	0.0012	0.0016	0.0030
80	100	0.0032	0.0043	0.0043	0.0055	0.0055	0.0071	0.0018	0.0022	0.0276	0.0335	0.0014	0.0020	0.0034
100	120	0.0039	0.0053	0.0053	0.0067	0.0067	0.0087	0.0020	0.0024	0.0295	0.0354	0.0018	0.0026	0.0043
120	140	0.0047	0.0063	0.0063	0.0079	0.0079	0.0102	0.0024	0.0028	0.0354	0.0433	0.0022	0.0032	0.0051
140	160	0.0051	0.0071	0.0071	0.0091	0.0091	0.0118	0.0026	0.0032	0.0394	0.0512	0.0024	0.0039	0.0059

⁽¹⁾ Valid for solid steel shafts only

The inner rings of tapered bore spherical roller bearings are always mounted with an interference fit. The farther the bearing is pushed up the taper, the greater the degree of interference and the greater the reduction of internal radial clearance within the bearing. It is necessary to measure this reduction as you mount the bearing to the shaft in order to have a properly functioning bearing. Use the following steps:

- 1 Do not start this procedure until you are ready to mount the bearing. If the mounting process is interrupted, cover the bearing and workspace to prevent contamination.
- 2 Start with a clean workspace ensuring that bench and tools are free from dirt, dust or other contaminants.
- 3 Remove the bearing from its container and inner wrap, standing the bearing upright on the bench. Rotate the inner ring of the bearing slowly for one revolution so that the rolling elements align themselves with the raceways. Make sure the inner ring is parallel with the outer ring.
- 4 Referring to Table 1, select as a starting point a feeler gauge in the mid-range of the bearings' unmounted clearance.
- 5 Using the top set of rollers, work the feeler gauge between the roller and the outer raceway. The correct gauge will create a slight resistance. Ensure that the gauge is being worked over both of the top rollers of each raceway for a correct reading. Your reading should be within the values in Table 1.
- 6 For a reading at the high end, use the maximum reduction value from Table 2. For a reading at the lower end, use the lower value from Table 2. Subtract the value you determine from Table 2 from Table 1. This is the final or residual clearance and cannot be less than the minimum residual clearance shown in Table 2. Write down what your final clearance should be after mounting.
- 7 Position the bearing and adapter sleeve on the shaft and tighten the lock nut, measuring the internal clearance at regular intervals, until the final clearance is reached. With the bearing suspended on the shaft, the clearance readings are taken at the bottom rather than the top.
- 8 Secure the lock washer tab in place. If necessary, continue to tighten the lock nut to align the washer tab and slot. Do not back off the lock nut to achieve this.

SHAFT TOLERANCE LIMITS FOR ADAPTER MOUNT

Imperial shaft tolerances for bearings with adapter mount are shown in table 3. These values may be converted to millimeters for metric sizes. For conversion to millimeters multiply by 25.4.

Table 3

Nominal Shaft Diameter		Diameter Tolerances		Max. Permissible Taper and Ovality
over	incl.	max	min	
.394	.709	+0.00	-.0017	.0003
.709	1.181	+0.00	-.0020	.0004
1.181	1.969	+0.00	-.0024	.0004
1.969	3.150	+0.00	-.0029	.0005
3.150	4.724	+0.00	-.0034	.0006
4.724	7.087	+0.00	-.0039	.0007

MOUNTING THE SNN SPLIT HOUSING USING G-LOK SEALS



- 1 Remove the top half of the bearing housing to expose the bearing seat.
- 2 Place the housing base in position and hand tighten the fixing bolts.
- 3 The G-LOK kit includes four halves (2 Seals). Fit the halves into the seal grooves machined in the base and top of the housing. To aid the lubrication of the running lips and sealing properties of the G-LOK, fill the u-section of the seal with grease.
- 4 Mount the bearing on the shaft and fill with grease.
- 5 Place the shaft and bearing assembly on the lower half of the split housing.
- 6 For the assembly that locates the system, fit the locating rings on either side of the bearing. Where only one is supplied fit it on the same side as the tapered sleeve lock nut.
- 7 Check the housings for alignment with each other, ensuring that they are within acceptable limits and that the fixing bolts are tightened sufficiently to secure the base.
- 8 The top half of the housing should be carefully aligned with the locating dowel pins and the bolts tightened. Be sure that the split housing is paired only with its original top half, as these parts are not interchangeable from one housing to another.
- 9 The fixing bolts can then be fully tightened.

MOUNTING THE SNN SPLIT HOUSING WITH OPEN V-RING SEALS



- 1 Remove the top half of the bearing housing to expose the bearing seat.
- 2 Place the housing base in position and hand tighten the fixing bolts.
- 3 Place a V-RING and counterface washer on the shaft. The counterface washer should be positioned to align with the seal groove machined in the housing and the V-RING.
- 4 Mount the bearing on the shaft and charge with grease.
- 5 Place the second V-RING and the counterface washer on the shaft.
- 6 The shaft and bearing assembly with the sealing components can then be lowered into the base of the housing, taking care to locate the rubber lip of the counterface washer in the split housing seal groove.
- 7 For the assembly that locates the system, fit the locating rings on either side of the bearing. Where only one is supplied fit it on the same side as the tapered sleeve lock nut.
- 8 Check the housings for alignment with each other, ensuring that they are within acceptable limits and that the fixing bolts are tight enough to secure the base.
- 9 The top half of the housing should be carefully aligned with the locating dowel pins and the bolts tightened. Be sure that the split housing is paired only with its original top half, as these parts are not interchangeable from one housing to another.
- 10 The fixing bolts can then be fully tightened.
- 11 The rubbing surfaces of the counterface washer should be smeared with grease to help reduce friction.
- 12 To ensure effective sealing, the V-RINGS should then be moved axially along the shaft until their sealing lips are in the correct location relative to the washers. A convenient way of moving the V-RINGS along the shaft is to use the shank of a long screwdriver while rotating the shaft and working the V-RING into position by hand.

SNN SPLIT PLUMMER BLOCK HOUSINGS

Shaft Dia. mm / in.	Complete Pillow Block Assembly	Housing	Standard Seal	Optional Seal	End Cover	Bearing	Adapter Sleeve	Fixing Rings Designation	Qty	Mass Complete (kg)
3/4	SNN1505-3/4G	SNN505	G505	V505,TS505E	A505	1205K	HE205	SR52x5	2	2.3
	SNN1605-3/4G	SNN506-605	G605	V605,TS605E	A605	1305K	HE305	SR62X7.5	2	2.3
20	SNN1505-20G	SNN505	G505	V505,TS505	A505	1205K	H205	SR52x5	2	2.3
	SNN2505-20G	SNN505	G505	V505,TS505	A505	2205K	H305	SR52X7	1	2.3
	SNN22505-20G	SNN505	G505	V505,TS505	A505	22205K	H305	SR52x7	1	2.3
	SNN1605-20G	SNN506-605	G605	V605,TS605	A605	1305K	H305	SR62X7.5	2	2.3
	SNN21605-20G	SNN506-605	G605	V605,TS605	A605	21305K	H305	SR62X7.5	2	2.3
	SNN2605-20G	SNN506-605	G605	V605,TS605	A605	2305K	H2305	SR62X8	1	2.4
15/16	SNN1506-15/16G	SNN506-605	G506	V506,TS506A	A506	1206K	HA206	SR62X8	2	2.3
	SNN1606-15/16G	SNN507-606	G606	V606,TS606A	A606	1306K	HA306	SR72X7.5	2	2.7
	SNN2606-15/16G	SNN507-606	G606	V606,TS606A	A606	2306K	HA2306	SR72X7	1	2.8
25	SNN1506-25G	SNN506-605	G506	V506,TS506	A506	1206K	H206	SR62X8	2	2.3
	SNN2506-25G	SNN506-605	G506	V506,TS506	A506	2206K	H306	SR62X12	1	2.4
	SNN22506-25G	SNN506-605	G506	V506,TS506	A506	22206K	H306	SR62X12	1	2.4
	SNN1606-25G	SNN507-606	G606	V606,TS606	A606	1306K	H306	SR72X7.5	2	2.7
	SNN21606-25G	SNN507-606	G606	V606,TS606	A606	21306K	H306	SR72X7.5	2	2.7
	SNN2606-25G	SNN507-606	G606	V606,TS606	A606	2306K	H2306	SR72X7	1	2.8
1	SNN1506-1G	SNN506-605	G506	V506,TS506E	A506	1206K	HE206	SR62X8	2	2.3
	SNN1606-1G	SNN507-606	G606	V606,TS606E	A606	1306K	HE306	SR72X7.5	2	2.7
	SNN2606-1G	SNN507-606	G606	V606,TS606E	A606	2306K	HE2306	SR72X7	1	2.8
30	SNN1507-30G	SNN507-606	G507	V507,TS507	A507	1207K	H207	SR72X8.5	2	2.7
	SNN2507-30G	SNN507-606	G507	V507,TS507	A507	2207K	H307	SR72X11	1	2.7
	SNN22507-30G	SNN507-606	G507	V507,TS507	A507	22207K	H307	SR72X11	1	2.8
	SNN1607-30G	SNN508-607	G607	V607,TS607	A607	1307K	H307	SR80X9	2	3.6
	SNN21607-30G	SNN508-607	G607	V607,TS607	A607	21307K	H307	SR80X9	2	3.6
	SNN2607-30G	SNN508-607	G607	V607,TS607	A607	2307K	H2307	SR80X8	1	3.7
1.3/16	SNN1507-1.3/16G	SNN507-606	G507	V507,TS507A	A507	1207K	HA207	SR72X8.5	2	2.7
	SNN1607-1.3/16G	SNN508-607	G607	V607,TS607A	A607	1307K	HA307	SR80X9	2	3.6
	SNN2607-1.3/16G	SNN508-607	G607	V607,TS607A	A607	2307K	HA2307	SR80X8	1	3.7
	SNN22507-1.3/16G	SNN507-606	G507	V507,TS507A	A507	22207K	HA307	SR72X11	1	2.8
1.1/4	SNN1508-1.1/4G	SNN508-607	G508E	V508E,TS508E	A508	1208K	HE208	SR80X10.5	2	3.6
	SNN1608-1.1/4G	SNN510-608	G608E	V608E,TS608E	A608	1308K	HE308	SR90X9	2	4.1
	SNN2608-1.1/4G	SNN510-608	G608E	V608E,TS608E	A608	2308K	HE2308	SR90X8	1	4.2
	SNN21608-1.1/4G	SNN510-608	G608E	V608E,TS608E	A608	21308K	HE308	SR90X9	2	4.1
	SNN22508-1.1/4G	SNN508-607	G508E	V508E,TS508E	A508	22208K	HE308	SR80X8	2	3.7
	SNN22608-1.1/4G	SNN510-608	G608E	V608E,TS608E	A608	22308K	HE2308	SR90X8	1	4.4
35	SNN1508-35G	SNN508-607	G508	V508,TS508	A508	1208K	H208	SR80X10.5	2	3.6
	SNN2508-35G	SNN508-607	G508	V508,TS508	A508	2208K	H308	SR80X8	2	3.6
	SNN22508-35G	SNN508-607	G508	V508,TS508	A508	22208K	H308	SR80X8	2	3.7
	SNN1608-35G	SNN510-608	G608	V608,TS608	A608	1308K	H308	SR90X9	2	4.1
	SNN21608-35G	SNN510-608	G608	V608,TS608	A608	21308K	H308	SR90X9	2	4.1
	SNN2608-35G	SNN510-608	G608	V608,TS608	A608	2308K	H2308	SR90X8	1	4.2
	SNN22608-35G	SNN510-608	G608	V608,TS608	A608	22308K	H2308	SR90X8	1	4.4

For housing dimensions see page 14. For information on how to order see page 4.

SNN SPLIT PLUMMER BLOCK HOUSINGS

Shaft Dia. mm / in.	Complete Pillow Block Assembly	Housing	Standard Seal	Optional Seal	End Cover	Bearing	Adapter Sleeve	Fixing Rings Designation	Qty	Mass Complete (kg)
1.7/16	SNN1509-1.7/16G	SNN509	G509A	V509A,TS509A	A509	1209K	HA209	SR85X5.5	2	3.7
	SNN1609-1.7/16G	SNN511-609	G609A	V609A,TS609A	A609	1309K	HA309	SR100X9.5	2	6.1
	SNN2609-1.7/16G	SNN511-609	G609A	V609A,TS609A	A609	2309K	HA2309	SR100X8	1	6.3
	SNN21609-1.7/16G	SNN511-609	G609A	V609A,TS609A	A609	21309K	HA309	SR100X9.5	2	6.1
	SNN22509-1.7/16G	SNN509	G509A	V509A,TS509A	A509	22209K	HA309	SR85X7	1	3.9
	SNN22609-1.7/16G	SNN511-609	G609A	V609A,TS609A	A609	22309K	HA2309	SR100X8	1	6.5
1.1/2	SNN1509-1.1/2G	SNN509	G509	V509,TS509E	A509	1209K	HE209	SR85X5.5	2	3.7
	SNN1609-1.1/2G	SNN511-609	G609	V609,TS609E	A609	1309K	HE309	SR100X9.5	2	6.1
	SNN2609-1.1/2G	SNN511-609	G609	V609,TS609E	A609	2309K	HE2309	SR100X8	1	6.3
	SNN21609-1.1/2G	SNN511-609	G609	V609,TS609E	A609	21309K	HE309	SR100X9.5	2	6.1
	SNN22509-1.1/2G	SNN509	G509	V509,TS509E	A509	22209K	HE309	SR85X7	1	3.9
	SNN22609-1.1/2G	SNN511-609	G609	V609,TS609E	A609	22309K	HE2309	SR100X8	1	6.5
40	SNN1509-40G	SNN509	G509	V509,TS509	A509	1209K	H209	SR85X5.5	2	3.7
	SNN2509-40G	SNN509	G509	V509,TS509	A509	2209K	H309	SR85X7	1	3.8
	SNN22509-40G	SNN509	G509	V509,TS509	A509	22209K	H309	SR85X7	1	3.9
	SNN1609-40G	SNN511-609	G609	V609,TS609	A609	1309K	H309	SR100X9.5	2	6.1
	SNN21609-40G	SNN511-609	G609	V609,TS609	A609	21309K	H309	SR100X9.5	2	6.1
	SNN2609-40G	SNN511-609	G609	V609,TS609	A609	2309K	H2309	SR100X8	1	6.3
	SNN22609-40G	SNN511-609	G609	V609,TS609	A609	22309K	H2309	SR100X8	1	6.5
1.11/16	SNN1510-1.11/16G	SNN510-608	G510	V510,TS510A	A510	1210K	HA210	SR90X10.5	2	4.0
	SNN1610-1.11/16G	SNN512-610	G610	V610,TS610A	A610	1310K	HA310	SR110X10.5	2	7.0
	SNN2610-1.11/16G	SNN512-610	G610	V610,TS610A	A610	2310K	HA2310	SR110X8	1	7.4
	SNN21610-1.11/16G	SNN512-610	G610	V610,TS610A	A610	21310K	HA310	SR110X10.5	2	7.0
	SNN22510-1.11/16G	SNN510-608	G510	V510,TS510A	A510	22210K	HA310	SR90X9	2	4.1
	SNN22610-1.11/16G	SNN512-610	G610	V610,TS610A	A610	22310K	HA2310	SR110X8	1	7.6
1.3/4	SNN1510-1.3/4G	SNN510-608	G510	V510,TS510E	A510	1210K	HE210	SR90X10.5	2	4.0
	SNN1610-1.3/4G	SNN512-610	G610	V610,TS610E	A610	1310K	HE310	SR110X10.5	2	7.0
	SNN2610-1.3/4G	SNN512-610	G610	V610,TS610E	A610	2310K	HE2310	SR110X8	1	7.4
	SNN21610-1.3/4G	SNN512-610	G610	V610,TS610E	A610	21310K	HE310	SR110X10.5	2	7.0
	SNN22510-1.3/4G	SNN510-608	G510	V510,TS510E	A510	22210K	HE310	SR90X9	2	4.1
	SNN22610-1.3/4G	SNN512-610	G610	V610,TS610E	A610	22310K	HE2310	SR110X8	1	7.6
45	SNN1510-45G	SNN510-608	G510	V510,TS510	A510	1210K	H210	SR90X10.5	2	4.0
	SNN2510-45G	SNN510-608	G510	V510,TS510	A510	2210K	H310	SR90X9	2	4.0
	SNN22510-45G	SNN510-608	G510	V510,TS510	A510	22210K	H310	SR90X9	2	4.1
	SNN1610-45G	SNN512-610	G610	V610,TS610	A610	1310K	H310	SR110X10.5	2	7.0
	SNN21610-45G	SNN512-610	G610	V610,TS610	A610	21310K	H310	SR110X10.5	2	7.0
	SNN2610-45G	SNN512-610	G610	V610,TS610	A610	2310K	H2310	SR110X8	1	7.4
	SNN22610-45G	SNN512-610	G610	V610,TS610	A610	22310K	H2310	SR110X8	1	7.6
1.15/16	SNN1511-1.15/16G	SNN511-609	G511	V511,TS511A	A511	1211K	HA211	SR100X11.5	2	5.9
	SNN1611-1.15/16G	SNN513-611	G611	V611,TS611A	A611	1311K	HA311	SR120X11	2	8.6
	SNN2611-1.15/16G	SNN513-611	G611	V611,TS611A	A611	2311K	HA2311	SR120X8	1	9.1
	SNN21611-1.15/16G	SNN513-611	G611	V611,TS611A	A611	21311K	HA311	SR120X11	2	8.6
	SNN22511-1.15/16G	SNN511-609	G511	V511,TS511A	A511	22211K	HA311	SR100X9.5	2	6.1
	SNN22611-1.15/16G	SNN513-611	G611	V611,TS611A	A611	22311K	HA2311	SR120X8	1	9.4

For housing dimensions see page 14. For information on how to order see page 4.

SNN SPLIT PLUMMER BLOCK HOUSINGS

Shaft Dia. mm / in.	Complete Pillow Block Assembly	Housing	Standard Seal	Optional Seal	End Cover	Bearing	Adapter Sleeve	Fixing Rings Designation	Qty	Mass Complete (kg)
50	SNN1511-50G	SNN511-609	G511	V511,TS511	A511	1211K	H211	SR100X11.5	2	5.9
	SNN2511-50G	SNN511-609	G511	V511,TS511	A511	2211K	H311	SR100X9.5	2	6.0
	SNN1611-50G	SNN513-611	G611	V611,TS611	A611	1311K	H311	SR120X11	2	8.6
	SNN2611-50G	SNN513-611	G611	V611,TS611	A611	2311K	H2311	SR120X8	1	9.1
	SNN21611-50G	SNN513-611	G611	V611,TS611	A611	21311K	H311	SR120X11	2	8.6
	SNN22511-50G	SNN511-609	G511	V511,TS511	A511	22211K	H311	SR100X9.5	2	6.1
	SNN22611-50G	SNN513-611	G611	V611,TS611	A611	22311K	H2311	SR120X8	1	9.4
2	SNN1511-2G	SNN511-609	G511	V511,TS511E	A511	1211K	HE211	SR100X11.5	2	5.9
	SNN1611-2G	SNN513-611	G611	V611,TS611E	A611	1311K	HE311	SR120X11	2	8.6
	SNN2611-2G	SNN513-611	G611	V611,TS611E	A611	2311K	HE2311	SR120X8	1	9.1
	SNN21611-2G	SNN513-611	G611	V611,TS611E	A611	21311K	HE311	SR120X11	2	8.6
	SNN22511-2G	SNN511-609	G511	V511,TS511E	A511	22211K	HE311	SR100X9.5	2	6.1
	SNN22611-2G	SNN513-611	G611	V611,TS611E	A611	22311K	HE2311	SR120X8	1	9.4
55	SNN1512-55G	SNN512-610	G512	V512,TS512	A512	1212K	H212	SR110X13	2	6.8
	SNN2512-55G	SNN512-610	G512	V512,TS512	A512	2212K	H312	SR110X10	2	6.9
	SNN1612-55G	SNN515-612	G612	V612,TS612	A612	1312K	H312	SR130X12.5	2	9.4
	SNN2612-55G	SNN515-612	G612	V612,TS612	A612	2312K	H2312	SR130X10	1	9.9
	SNN21612-55G	SNN515-612	G612	V612,TS612	A612	21312K	H312	SR130X12.5	2	9.4
	SNN22512-55G	SNN512-610	G512	V512,TS512	A512	22212K	H312	SR110X10	2	7.1
	SNN22612-55G	SNN515-612	G612	V612,TS612	A612	22312K	H2312	SR130X10	1	10.3
2.3/16	SNN1513-2.3/16G	SNN513-611	G513A	V513A,TS513A	A513	1213K	HA213	SR120X14	2	8.3
	SNN1613-2.3/16G	SNN516-613	G613A	V613A,TS613A	A613	1313K	HA313	SR140X12.5	2	13.4
	SNN2613-2.3/16G	SNN516-613	G613A	V613A,TS613A	A613	2313K	HA2313	SR140X10	1	14.0
	SNN21613-2.3/16G	SNN516-613	G613A	V613A,TS613A	A613	21313K	HA313	SR140X12.5	2	13.3
	SNN22513-2.3/16G	SNN513-611	G513A	V513A,TS513A	A513	22213K	HA313	SR120X10	2	8.7
	SNN22613-2.3/16G	SNN516-613	G613A	V613A,TS613A	A613	22313K	HA2313	SR140X10	1	14.4
2.1/4	SNN1513-2.1/4G	SNN513-611	G513	V513,TS513E	A513	1213K	HE213	SR120X14	2	8.3
	SNN1613-2.1/4G	SNN516-613	G613	V613,TS613E	A613	1313K	HE313	SR140X12.5	2	13.4
	SNN2613-2.1/4G	SNN516-613	G613	V613,TS613E	A613	2313K	HE2313	SR140X10	1	14.0
	SNN21613-2.1/4G	SNN516-613	G613	V613,TS613E	A613	21313K	HE313	SR140X12.5	2	13.3
	SNN22513-2.1/4G	SNN513-611	G513	V513,TS513E	A513	22213K	HE313	SR120X10	2	8.7
	SNN22613-2.1/4G	SNN516-613	G613	V613,TS613E	A613	22313K	HE2313	SR140X10	1	14.4
60	SNN1513-60G	SNN513-611	G513	V513,TS513	A513	1213K	H213	SR120X14	2	8.3
	SNN2513-60G	SNN513-611	G513	V513,TS513	A513	2213K	H313	SR120X10	2	8.6
	SNN1613-60G	SNN516-613	G613	V613,TS613	A613	1313K	H313	SR140X12.5	2	13.4
	SNN2613-60G	SNN516-613	G613	V613,TS613	A613	2313K	H2313	SR140X10	1	14.0
	SNN21613-60G	SNN516-613	G613	V613,TS613	A613	21313K	H313	SR140X12.5	2	13.3
	SNN22513-60G	SNN513-611	G513	V513,TS513	A513	22213K	H313	SR120X10	2	8.7
	SNN22613-60G	SNN516-613	G613	V613,TS613	A613	22313K	H2313	SR140X10	1	14.4
2.7/16	SNN1515-2.7/16G	SNN515-612	G515	V515,TS515A	A515	1215K	HA215	SR130X15.5	2	9.1
	SNN1615-2.7/16G	SNN518-615	G615	V615,TS615A	A615	1315K	HA315	SR160X14	2	17.5
	SNN2615-2.7/16G	SNN518-615	G615	V615,TS615A	A615	2315K	HA2315	SR160X10	1	18.9
	SNN21615-2.7/16G	SNN518-615	G615	V615,TS615A	A615	21315K	HA315	SR160X14	2	17.5
	SNN22515-2.7/16G	SNN515-612	G515	V515,TS515A	A515	22215K	HA315	SR130X12.5	2	9.5
	SNN22615-2.7/16G	SNN518-615	G615	V615,TS615A	A615	22315K	HA2315	SR160X10	1	19.4

For housing dimensions see page 14. For information on how to order see page 4.

SNN SPLIT PLUMMER BLOCK HOUSINGS

Shaft Dia. mm / in.	Complete Pillow Block Assembly	Housing	Standard Seal	Optional Seal	End Cover	Bearing	Adapter Sleeve	Fixing Rings Designation	Qty	Mass Complete (kg)
2.1/2	SNN1515-2.1/2G	SNN515-612	G515	V515,TS515E	A515	1215K	HE215	SR130X15.5	2	9.1
	SNN1615-2.1/2G	SNN518-615	G615	V615,TS615E	A615	1315K	HE315	SR160X14	2	17.5
	SNN2615-2.1/2G	SNN518-615	G615	V615,TS615E	A615	2315K	HE2315	SR160X10	1	18.9
	SNN21615-2.1/2G	SNN518-615	G615	V615,TS615E	A615	21315K	HE315	SR160X14	2	17.5
	SNN22515-2.1/2G	SNN515-612	G515	V515,TS515E	A515	22215K	HE315	SR130X12.5	2	9.5
	SNN22615-2.1/2G	SNN518-615	G615	V615,TS615E	A615	22315K	HE2315	SR160X10	1	19.4
65	SNN1515-65G	SNN515-612	G515	V515,TS515	A515	1215K	H215	SR130X15.5	2	9.1
	SNN2515-65G	SNN515-612	G515	V515,TS515	A515	2215K	H315	SR130X12.5	2	9.4
	SNN1615-65G	SNN518-615	G615	V615,TS615	A615	1315K	H315	SR160X14	2	17.5
	SNN2615-65G	SNN518-615	G615	V615,TS615	A615	2315K	H2315	SR160X10	1	18.9
	SNN21615-65G	SNN518-615	G615	V615,TS615	A615	21315K	H315	SR160X14	2	17.5
	SNN22515-65G	SNN515-612	G515	V515,TS515	A515	22215K	H315	SR130X12.5	2	9.5
SNN22615-65G	SNN518-615	G615	V615,TS615	A615	22315K	H2315	SR160X10	1	19.4	
2.11/16	SNN1516-2.11/16G	SNN516-613	G516	V516,TS516A	A516	1216K	HA216	SR140X16	2	13.0
	SNN1616-2.11/16G	SNN519-616	G616	V616,TS616A	A616	1316K	HA316	SR170X14.5	2	19.9
	SNN2616-2.11/16G	SNN519-616	G616	V616,TS616A	A616	2316K	HA2316	SR170X10	1	21.5
	SNN21616-2.11/16G	SNN519-616	G616	V616,TS616A	A616	21316K	HA316	SR170X14.5	2	20.0
	SNN22516-2.11/16G	SNN516-613	G516	V516,TS516A	A516	22216K	HA316	SR140X12.5	2	13.4
	SNN22616-2.11/16G	SNN519-616	G616	V616,TS616A	A616	22316K	HA2316	SR170X10	1	22.3
2.3/4	SNN1516-2.3/4G	SNN516-613	G516	V516,TS516E	A516	1216K	HE216	SR140X16	2	13.0
	SNN1616-2.3/4G	SNN519-616	G616	V616,TS616E	A616	1316K	HE316	SR170X14.5	2	19.9
	SNN2616-2.3/4G	SNN519-616	G616	V616,TS616E	A616	2316K	HE2316	SR170X10	1	21.5
	SNN21616-2.3/4G	SNN519-616	G616	V616,TS616E	A616	21316K	HE316	SR170X14.5	2	20.0
	SNN22516-2.3/4G	SNN516-613	G516	V516,TS516E	A516	22216K	HE316	SR140X12.5	2	13.4
	SNN22616-2.3/4G	SNN519-616	G616	V616,TS616E	A616	22316K	HE2316	SR170X10	1	22.3
70	SNN1516-70G	SNN516-613	G516	V516,TS516	A516	1216K	H216	SR140X16	2	13.0
	SNN2516-70G	SNN516-613	G516	V516,TS516	A516	2216K	H316	SR140X12.5	2	13.3
	SNN1616-70G	SNN519-616	G616	V616,TS616	A616	1316K	H316	SR170X14.5	2	19.9
	SNN2616-70G	SNN519-616	G616	V616,TS616	A616	2316K	H2316	SR170X10	1	21.5
	SNN21616-70G	SNN519-616	G616	V616,TS616	A616	21316K	H316	SR170X14.5	2	20.0
	SNN22516-70G	SNN516-613	G516	V516,TS516	A516	22216K	H316	SR140X12.5	2	13.4
	SNN22616-70G	SNN519-616	G616	V616,TS616	A616	22316K	H2316	SR170X10	1	22.3
	SNN22616-70G	SNN519-616	G616	V616,TS616	A616	22316K	H2316	SR170X10	1	22.3
2.15/16	SNN1517-2.15/16G	SNN517	G517	V517,TS517A	A517	1217K	HA217	SR150X16.5	2	14.5
	SNN1617-2.15/16G	SNN520-617	G617	V617,TS617A	A617	1317K	HA317	SR180X14.5	2	24.8
	SNN2617-2.15/16G	SNN520-617	G617	V617,TS617A	A617	2317K	HA2317	SR180X10	1	26.4
	SNN21617-2.15/16G	SNN520-617	G617	V617,TS617A	A617	21317K	HA317	SR180X14.5	2	24.8
	SNN22517-2.15/16G	SNN517	G517	V517,TS517A	A517	22217K	HA317	SR150X12.5	2	15.2
	SNN22617-2.15/16G	SNN520-617	G617	V617,TS617A	A617	22317K	HA2317	SR180X10	1	27.2
75	SNN1517-75G	SNN517	G517	V517,TS517	A517	1217K	H217	SR150X16.5	2	14.5
	SNN2517-75G	SNN517	G517	V517,TS517	A517	2217K	H317	SR150X12.5	2	15.0
	SNN1617-75G	SNN520-617	G617	V617,TS617	A617	1317K	H317	SR180X14.5	2	24.8
	SNN2617-75G	SNN520-617	G617	V617,TS617	A617	2317K	H2317	SR180X10	1	26.4
	SNN21617-75G	SNN520-617	G617	V617,TS617	A617	21317K	H317	SR180X14.5	2	24.8
	SNN22517-75G	SNN517	G517	V517,TS517	A517	22217K	H317	SR150X12.5	2	15.2
	SNN22617-75G	SNN520-617	G617	V617,TS617	A617	22317K	H2317	SR180X10	1	27.2

For housing dimensions see page 14. For information on how to order see page 4.

SNN SPLIT PLUMMER BLOCK HOUSINGS

Shaft Dia. mm / in.	Complete Pillow Block Assembly	Housing	Standard Seal	Optional Seal	End Cover	Bearing	Adapter Sleeve	Fixing Rings Designation	Qty	Mass Complete (kg)
3	SNN1517-3G	SNN517	G517	V517E,TS517E	A517	1217K	HE217	SR150X16.5	2	14.5
	SNN1617-3G	SNN520-617	G617	V617E,TS617E	A617	1317K	HE317	SR180X14.5	2	24.8
	SNN2617-3G	SNN520-617	G617	V617E,TS617E	A617	2317K	HE2317	SR180X10	1	26.4
	SNN21617-3G	SNN520-617	G617	V617E,TS617E	A617	21317K	HE317	SR180X14.5	2	24.8
	SNN22517-3G	SNN517	G517	V517E,TS517E	A517	22217K	HE317	SR150X12.5	2	15.2
	SNN22617-3G	SNN520-617	G617	V617E,TS617E	A617	22317K	HE2317	SR180X10	1	27.2
80	SNN1518-80G	SNN518-615	G518	V518,TS518	A518	1218K	H218	SR160X17.5	2	17.0
	SNN22518-80G	SNN518-615	G518	V518,TS518	A518	22218K	H318	SR160X12.5	2	18.0
	SNN23518-80G	SNN518-615	G518	V518,TS518	A518	23218K	H2318	SR160X12.5	1	19.3
3.3/16	SNN1518-3.3/16G	SNN518-615	G518	V518,TS518A	A518	1218K	HA218	SR160X17.5	2	17.0
	SNN22518-3.3/16G	SNN518-615	G518	V518,TS518A	A518	22218K	HA318	SR160X12.5	2	18.0
	SNN23518-3.3/16G	SNN518-615	G518	V518,TS518A	A518	23218K	HA2318	SR160X12.5	1	19.3
3.1/4	SNN1518-3.1/4G	SNN518-615	G518	V518E,TS518E	A518	1218K	HE218	SR160X17.5	2	17.0
	SNN22518-3.1/4G	SNN518-615	G518	V518E,TS518E	A518	22218K	HE318	SR160X12.5	2	18.0
	SNN23518-3.1/4G	SNN518-615	G518	V518E,TS518E	A518	23218K	HE2318	SR160X12.5	1	19.3
85	SNN1519-85G	SNN519-616	G519	V519,TS519	A519	1219K	H219	SR170X18	2	19.2
	SNN2519-85G	SNN519-616	G519	V519,TS519	A519	2219K	H319	SR170X12.5	2	20.2
	SNN22519-85G	SNN519-616	G519	V519,TS519	A519	22219K	H319	SR170X12.5	2	20.5
	SNN22619-85G	SNN522-619	G619	V619,TS619	A619	22319K	H2319	SR200X13	1	36.3
3.7/16	SNN1520-3.7/16G	SNN520-617	G520	V520,TS520A	A520	1220K	HA220	SR180X18	2	23.7
	SNN1620-3.7/16G	SNN524-620	G620	V620,TS620A	A620	1320K	HA320	SR215X19.5	2	36.5
	SNN21620-3.7/16G	SNN524-620	G620	V620,TS620A	A620	21320K	HA320	SR215X19.5	2	37.4
	SNN22520-3.7/16G	SNN520-617	G520	V520,TS520A	A520	22220K	HA320	SR180X12	2	25.3
	SNN22620-3.7/16G	SNN524-620	G620	V620,TS620A	A620	22320K	HA2320	SR215X13	1	41.1
	SNN23520-3.7/16G	SNN520-617	G520	V520,TS520A	A520	23220K	HA2320	SR180X9.5	1	27.2
3.1/2	SNN1520-3.1/2G	SNN520-617	G520	V520,TS520E	A520	1220K	HE220	SR180X18	2	23.7
	SNN1620-3.1/2G	SNN524-620	G620	V620,TS620E	A620	1320K	HE320	SR215X19.5	2	36.5
	SNN21620-3.1/2G	SNN524-620	G620	V620,TS620E	A620	21320K	HE320	SR215X19.5	2	37.4
	SNN22520-3.1/2G	SNN520-617	G520	V520,TS520E	A520	22220K	HE320	SR180X12	2	25.3
	SNN22620-3.1/2G	SNN524-620	G620	V620,TS620E	A620	22320K	HE2320	SR215X13	1	41.4
	SNN23520-3.1/2G	SNN520-617	G520	V520,TS520E	A520	23220K	HE2320	SR180X9.5	1	27.2
90	SNN1520-90G	SNN520-617	G520	V520,TS520	A520	1220K	H220	SR180X18	2	23.7
	SNN22520-90G	SNN520-617	G520	V520,TS520	A520	22220K	H320	SR180X12	2	25.3
	SNN22620-90G	SNN524-620	G620	V620,TS620	A620	22320K	H2320	SR215X13	1	41.1
	SNN23520-90G	SNN520-617	G520	V520,TS520	A520	23220K	H2320	SR180X9.5	1	27.2
100	SNN1522-100G	SNN522-619	G522	V522,TS522	A522	1222K	H222	SR200X21	2	31.4
	SNN22522-100G	SNN522-619	G522	V522,TS522	A522	22222K	H322	SR200X13.5	2	33.9
	SNN23522-100G	SNN522-619	G522	V522,TS522	A522	23222K	H2322	SR200X10	1	36.5
3.15/16	SNN1522-3.15/16G	SNN522-619	G522	V522,TS522A	A522	1222K	H222	SR200X21	2	31.4
	SNN22522-3.15/16G	SNN522-619	G522	V522,TS522A	A522	22222K	H322	SR200X13.5	2	33.9
	SNN23522-3.15/16G	SNN522-619	G522	V522,TS522A	A522	23222K	H2322	SR200X10	1	36.5

For housing dimensions see page 14. For information on how to order see page 4.

SNN SPLIT PLUMMER BLOCK HOUSINGS

Shaft Dia. mm / in.	Complete Pillow Block Assembly	Housing	Standard Seal	Optional Seal	End Cover	Bearing	Adapter Sleeve	Fixing Rings Designation	Qty	Mass Complete (kg)
4	SNN1522-4G	SNN522-619	G522	V522,TS522E	A522	1222K	HE222	SR200X21	2	31.4
	SNN22522-4G	SNN522-619	G522	V522,TS522E	A522	22222K	HE322	SR200X13.5	2	33.9
	SNN23522-4G	SNN522-619	G522	V522,TS522E	A522	23222K	HE2322	SR200X10	1	36.5
4.3/16	SNN22524-4.3/16G	SNN524-620	G524	V524,TS524A	A524	22224K	HA3124	SR215X14	2	38.1
	SNN23524-4.3/16G	SNN524-620	G524	V524,TS525A	A524	23224K	HA2324	SR215X10	1	41.7
4.1/4	SNN22524-4.1/4G	SNN524-620	G524	V524,TS524E	A524	22224K	HE3124	SR215X14	2	38.1
	SNN23524-4.1/4G	SNN524-620	G524	V524,TS524E	A524	23224K	HE2324	SR215X10	1	41.7
110	SNN22524-110G	SNN524-620	G524	V524,TS524	A524	22224K	H3124	SR215X14	2	38.1
	SNN23524-110G	SNN524-620	G524	V524,TS524	A524	23224K	H2324	SR215X10	1	41.7
4.7/16	SNN22526-4.7/16G	SNN526	G526	V526,TS526A	A526	22226K	HA3126	SR230X13	2	48.3
	SNN23526-4.7/16G	SNN526	G526	V526,TS526A	A526	23226K	HA2326	SR230X10	1	52.1
4.1/2	SNN22526-4.1/2G	SNN526	G526	V526,TS526E	A526	22226K	HE3126	SR230X13	2	48.3
	SNN23526-4.1/2G	SNN526	G526	V526,TS526E	A526	23226K	HE2326	SR230X10	1	52.1
115	SNN22526-115G	SNN526	G526	V526,TS526	A526	22226K	H3126	SR230X13	2	48.3
	SNN23526-115G	SNN526	G526	V526,TS526	A526	23226K	H2326	SR230X10	1	52.1
125	SNN22528-125G	SNN528	G528	V528,TS528	A528	22228K	H3128	SR250X15	2	59.3
	SNN23528-125G	SNN528	G528	V528,TS528	A528	23228K	H2328	SR250X10	1	64.6
4.15/16	SNN22528-4.15/16G	SNN528	G528	V528,TS528A	A528	22228K	HA3128	SR250X15	2	59.3
	SNN23528-4.15/16G	SNN528	G528	V528,TS528A	A528	23228K	HA2328	SR250X10	1	64.6
5	SNN22528-5G	SNN528	G528	V528E,TS528E	A528	22228K	HE3128	SR250X15	2	59.3
	SNN23528-5G	SNN528	G528	V528E,TS528E	A528	23228K	HE2328	SR250X10	1	64.6
5.3/16	SNN22530-5.3/16G	SNN530	G530	V530,TS530A	A530	22230K	HA3130	SR270X16.5	2	73.4
	SNN23530-5.3/16G	SNN530	G530	V530,TS530A	A530	23230K	HA2330	SR270X10	1	80.1
5.1/4	SNN22530-5.1/4G	SNN530	G530	V530,TS530E	A530	22230K	HE3130	SR270X16.5	2	73.4
	SNN23530-5.1/4G	SNN530	G530	V530,TS530E	A530	23230K	HE2330	SR270X10	1	80.1
135	SNN22530-135G	SNN530	G530	V530,TS530	A530	22230K	H3130	SR270X16.5	2	73.4
	SNN23530-135G	SNN530	G530	V530,TS530	A530	23230K	H2330	SR270X10	1	80.1
5.7/16	SNN22532-5.7/16G	SNN532	G532	V532,TS532A	A532	22232K	HA3132	SR290X17	2	86.3
	SNN23532-5.7/16G	SNN532	G532	V532,TS532A	A532	23232K	HA2332	SR290X10	1	95.0
5.1/2	SNN22532-5.1/2G	SNN532	G532	V532,TS532E	A532	22232K	HE3132	SR290X17	2	86.3
	SNN23532-5.1/2G	SNN532	G532	V532,TS532E	A532	23232K	HE2332	SR290X10	1	95.0
140	SNN22532-140G	SNN532	G532	V532,TS532	A532	22232K	H3132	SR290X17	2	86.3
	SNN23532-140G	SNN532	G532	V532,TS532	A532	23232K	H2332	SR290X10	1	95.0

For housing dimensions see page 14. For information on how to order see page 4.

SNN SPLIT PLUMMER BLOCK HOUSINGS

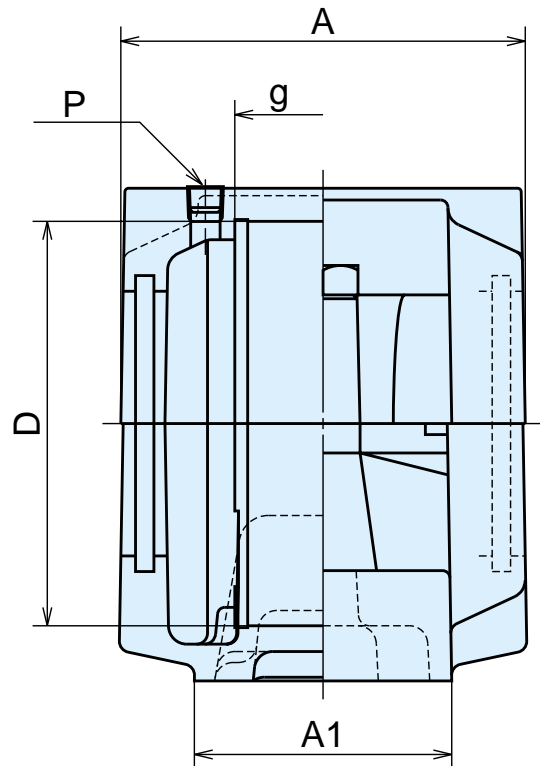
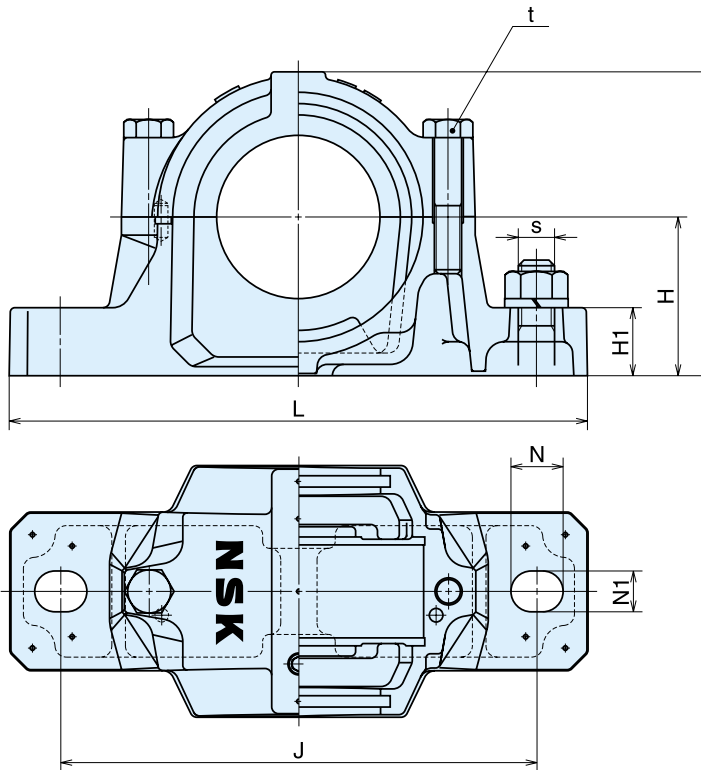

Housing No.	D	H	J	A	L	A1	H1	H2	g	t	Nm ⁽¹⁾	N	N1	s	P	Mass (kg)
SNN505	52	40	130	70	165	46	22	73	25	M10	44	20	15	M12	R 1/8	2.0
SNN506-605	62	50	150	80	185	52	22	88	32	M10	44	20	15	M12	R 1/8	2.0
SNN507-606	72	50	150	85	185	52	22	93	34	M10	44	20	15	M12	R 1/8	2.2
SNN508-607	80	60	170	90	205	60	25	107	39	M10	44	20	15	M12	R 1/8	2.9
SNN509	85	60	170	90	205	60	25	111	30	M10	44	20	15	M12	R 1/8	3.0
SNN510-608	90	60	170	95	205	60	25	113	41	M10	44	20	15	M12	R 1/8	3.1
SNN511-609	100	70	210	100	255	70	28	129	44	M12	76	24	18	M16	R 1/8	4.8
SNN512-610	110	70	210	110	255	70	30	134	48	M12	76	24	18	M16	R 1/8	5.4
SNN513-611	120	80	230	115	275	80	30	150	51	M12	76	24	18	M16	R 1/8	6.6
SNN515-612	130	80	230	120	280	80	30	155	56	M12	76	24	18	M16	R 1/8	6.8
SNN516-613	140	95	260	130	315	90	32	175	58	M16	190	28	22	M20	R 1/4	10.2
SNN517	150	95	260	135	320	90	32	183	61	M16	190	28	22	M20	R 1/4	11.2
SNN518-615	160	100	290	145	345	100	35	193	65	M16	190	28	22	M20	R 1/4	13.0
SNN519-616	170	112	290	145	345	100	35	210	68	M16	190	28	22	M20	R 1/4	14.5
SNN520-617	180	112	320	160	380	110	40	215	70	M20	370	32	26	M24	R 1/4	18.3
SNN522-619	200	125	350	175	410	120	45	240	80	M20	370	32	26	M24	R 1/4	24.0
SNN524-620	215	140	350	185	410	120	45	271	86	M20	370	32	26	M24	R 3/8	26.2
SNN526	230	150	380	190	445	130	50	288	90	M24	640	35	28	M24	R 3/8	33.0
SNN528	250	150	420	205	500	150	50	298	98	M24	640	42	35	M30	R 3/8	40.0
SNN530	270	160	450	220	530	160	60	322	106	M24	640	42	35	M30	R 3/8	49.0
SNN532	290	170	470	235	550	160	60	342	114	M24	640	42	35	M30	R 3/8	55.0

(1) Recommended tightening torque for cap bolts in newton meters (Nm)

SNN SPLIT PLUMMER BLOCK HOUSINGS

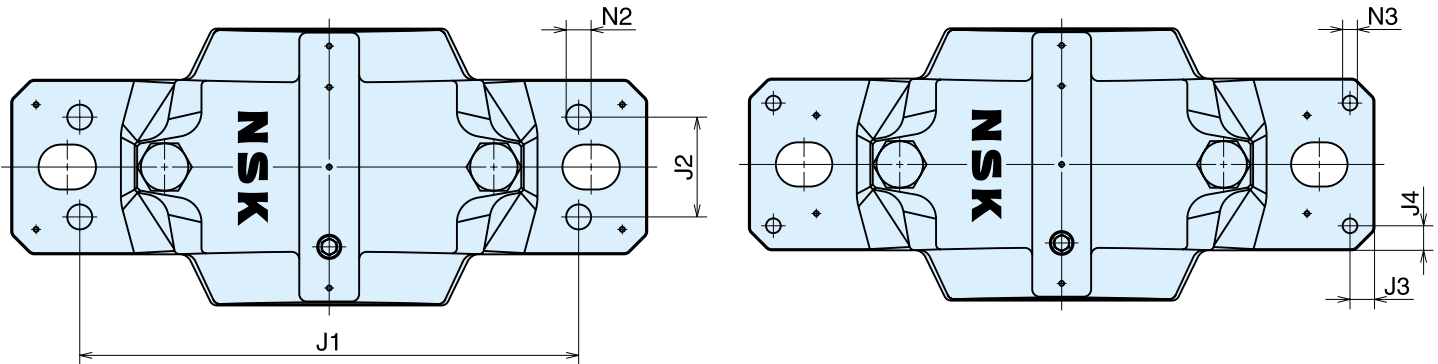

**Recommended dimensions
for 4-Bolt mounting (mm)**

Housing No.	J1	J2	N2	Bolt Size
SNN508-607	160	34	11	M10
SNN509	160	34	11	M10
SNN510-608	160	34	11	M10
SNN511-609	200	40	14	M12
SNN512-610	200	40	14	M12
SNN513-611	210	48	14	M12
SNN515-612	220	48	14	M12
SNN516-613	244	52	18	M16
SNN517	254	52	18	M16
SNN518-615	275	58	18	M16
SNN519-616	275	58	18	M16
SNN520-617	300	66	18	M16
SNN522-619	320	74	18	M16
SNN524-620	320	74	18	M16
SNN526	355	84	22	M20
SNN528	400	92	26	M24
SNN530	430	100	26	M24
SNN532	450	100	26	M24

**Recommended dimensions
for locating pins (mm)**

Housing No.	J3	J4	N3 Max.
SNN505	7	7	6
SNN506-605	8	8	6
SNN507-606	8	8	6
SNN508-607	9	9	8
SNN509	9	9	8
SNN510-608	9	9	8
SNN511-609	10	10	10
SNN512-610	10	10	10
SNN513-611	12	12	10
SNN515-612	12	12	10
SNN516-613	15	15	12
SNN517	15	15	12
SNN518-615	15	15	12
SNN519-616	15	15	12
SNN520-617	15	15	12
SNN522-619	18	18	16
SNN524-620	18	18	16
SNN526	18	18	16
SNN528	18	18	16
SNN530	18	18	16
SNN532	18	18	16

MONTREAL

2150-32e Avenue
Lachine, QC
H8T 3H7
Tel: (514) 633-1220
Fax: (514) 633-8164
Wats: 1-800-361-5861

TORONTO

5585 McAdam Road
Mississauga, ON
L4Z 1N4
Tel: (905) 890-0561
Fax: (905) 890-1938
Wats: 1-800-387-9362

EDMONTON

9267-41 Avenue
Edmonton, AB
T6E 6R5
Wats: 1-800-663-5445

VANCOUVER

3353 Wayburne Drive
Burnaby, BC
V5G 4L4
Tel: (604) 294-1151
Fax: (604) 294-1407
Wats: 1-800-663-5445

HEAD OFFICE

5585 McAdam Road
Mississauga, ON
L4Z 1N4
Tel: (905) 890-0740
Fax: (905) 890-0434

www.ca.nsk.com
info@ca.nsk.com

Disclaimer

While every effort and care has been taken to assure the accuracy and completeness of the information presented here, NSK assumes no liability for any loss or damage through errors or omissions. Through product development, NSK reserves the right to make future changes to product specifications without prior notice.

