

Rex[®]

**Belt Conveyor Components,
Whisperol[®] Conveyor Rollers and Spray Nozzles**

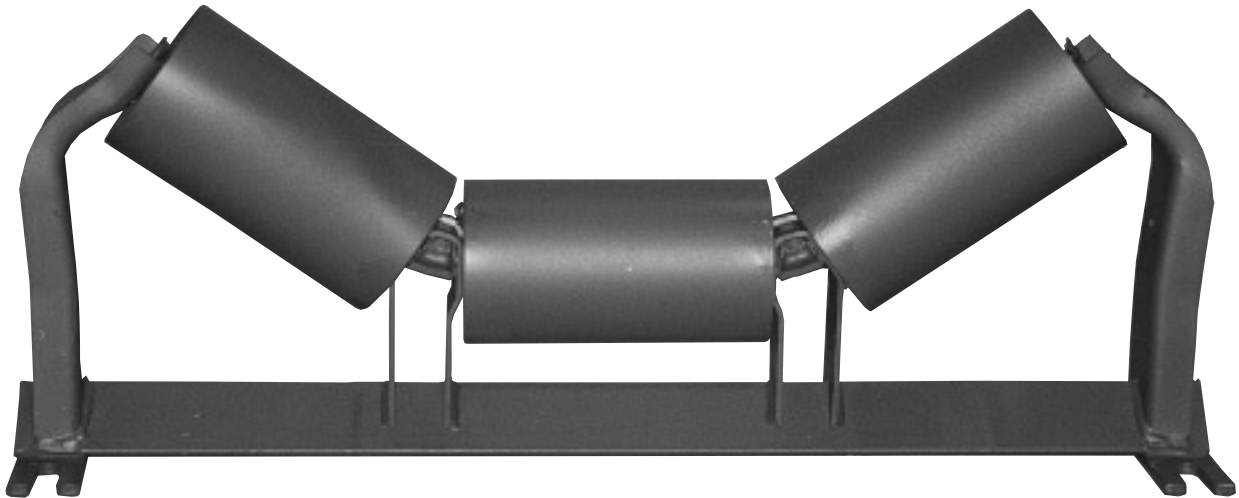

TABLE OF CONTENTS

	Page Number		Page Number
BELT CONVEYOR IDLERS		ORDERING INFORMATION	
Alphabetical Index	2	Complete Roll Assemblies	63
CEMA and Rex Idler Classification	3	Replacement Parts	64 – 65
Identification Guide	3	Brackets	66
Idler Interchange	4	Parts Interchangeability	67
The Rex Line	5	CATENARY	68 – 69
Types of Idlers	6 – 7	WEIGHT OF ROTATING PARTS	70
Model Number Index	8 – 9	IDLER SELECTION	71 – 81
Styles and Page Location	10	IDLER SPECIFICATIONS	82 – 83
SEALS	11	MAINTENANCE	84 – 87
DIMENSIONS AND WEIGHTS		CONVEYOR TROUBLE SHOOTING	88
Series B and B+	12 – 21	POLYMERIC CONVEYOR ROLLERS (WHISPEROL[®])	90 – 92
Series C and D	22 – 43	SPRAY NOZZLES	93 – 98
Series C and D Polyethylene	44 – 46		
Side Guides	46 – 47		
Series E	48 – 60		
Live Shaft Idlers	61		
Idler Problem Solvers	62		

INDEX

A		Model Number Index	8, 9
Alignment, Idler	84 – 88	N	
Angle of Repose	71 – 73	Nozzle, Flat Spray	93 – 97
Angle of Surcharge	71 – 73	Numbering System, Idler	3
B		O	
Bearing, Replacement	64, 65	Ordering Information	46, 63 – 67, 92, 98
Belt Conveyor, Illustration	6	P	
Belt - Capacity	74 – 76	Parts Interchangeability	65 – 67
- Speed	74 – 76	Polyethylene Roll, Idler	44 – 46
- Weight	77	Polymeric Conveyor Rollers	90 – 92
- Width	74 – 76	Problem Solvers, Idler	62
Brackets - Drop/Rise	64 – 66	Product Specifications, Idler	82, 83
C		Properties of Conveyed Material	72, 73
Capacity, Belt	74 – 76	R	
Catenary Idler	68, 69	Rating, Idler Load	80
CEMA Classification –	3	Regreasable Idler Specifications	82
CEMA B & B+	12 – 21	Replacement Parts–	
CEMA C & D	22 – 43	Bearing	64
CEMA E	48 – 60	Roll	63
Central Pivot, Training Idler	65	Seal	64
Ceramic –		Shafting	64
Coated Rolls	62	Repose, Angle of	71 – 73
Disc Rolls	62	Return Idler –	
Coated Roll	62	Disc Roll	7
Conveyor –		Spiral Roll	7
Illustration	6	Steel Roll	7
Property of Material	72, 73	Flex Wall Return Roller	47
D		Rex Ribbed® Training Idler	42
Dimensions –		Ribbed Covered	41
Catenary Idler	68, 69	Roll –	
Live Shaft Idler	61	Gap	82, 83
Series B & B+ Idler	12 – 21	Recommendations	81
Series C & D Idler	22 – 43	Weight of Rotating Parts	70
Series E Idler	48 – 60	Rotating Parts, Roll, Weight of	70
Side Guide Idler	46, 47	S	
Disc Return Idler	21, 40, 56, 58, 59	Safety Instructions	84
F		Seals, Idler	11
Factory Sealed Idler Specifications	83	Seal Kits, Idler	65 – 66
Flat Idler	6, 18, 36, 57, 61	Selection Procedure	
Flat Spray Nozzle	93 – 98	Idler	71 – 81
Flex Wall Return Roller	47	Nozzle	93 – 98
Rex Ribbed® Training Idler	42	Self Aligning Idler (Trainer)	6, 7
Ribbed Covered Return Idler	41	Shafting, Replacement	65
G		Side Guide Idler	46, 47
Guide, Side-Idler	46 – 47	Spacing, Idler	78, 81
Gap, Roll	82, 83	Specific Function Idler	82, 83
I		Specification, Idler	82, 83
Identification Guide	3	Speed, Belt	74 – 76, 80
Idler –		Spiral Return Idler	7
Alignment	84 – 88	Spray Nozzle, Flat	93 – 98
Index	8 – 10	Styles, Idler	6, 7
Load Rating (Table 14)	80	Surcharge Angle	71
Selection	71 – 81	T	
Series B & B+	12 – 21	Tilt, Idler	86
Series C & D	22 – 43	Flex Wall Return Roller	47
Series E	48 – 60	Rex Ribbed® Training Idler	42
Specification	82, 83	Ribbed Covered Return Idler	41
Types	6, 7	Training, Belt	84 – 87
Impact, Idler (Trough & Flat)	6	Training, Idler	6, 7
Inspection, Conveyor	84 – 87	Training Idler, Conversion	67
Installation, Idler	84 – 87	Transition Idler, Spacing	81
Interchange, Idler	4	Trouble-Shooting, Conveyor	89
L		Troughing Idler	6, 7
Line, Idler	5	Types, Idler	6, 7
Live Shaft Idler - Steel & Rubber	61	U	
Load Rating, Idler (Table 14)	80	Urethane –	
Loading, Conveyor	84 – 87	Coated Rolls	62
Lubrication, Idler	87 – 88	Disc Rolls	62
M		W	
Material Characteristics	71	Weight, Idler	(See Dimension Tables)
Material, Conveying Properties of	72, 73	Weight of Rotating Parts, Roll	70
Maintenance	84 – 88	Wide Base Idler	67
2		Width, Belt	71 – 81

REX IDLERS

CEMA AND REX IDLER CLASSIFICATION

Service Class	CEMA Class	Rex Series	Roll Diam. Inches	Rex Bearing Type	Belt Widths Inches
Light Duty	B	B	4 5	Ball	18-48
		B+	4 5	Roller	18-48
Medium Duty	C	C	5 6	Roller	18-60
	D	D	5 6	Roller	18-72
Heavy Duty	E	E	6 7	Roller	36-72

For idler selection procedure and idler load ratings, see pages 71 – 81. For product specifications see pages 82 – 83.

IDENTIFICATION GUIDE AND ORDERING INFORMATION

The following is an example of the Rex Idler Numbering System.

Rex Idler Model: 36-C5300FS
This number describes the idler as follows:

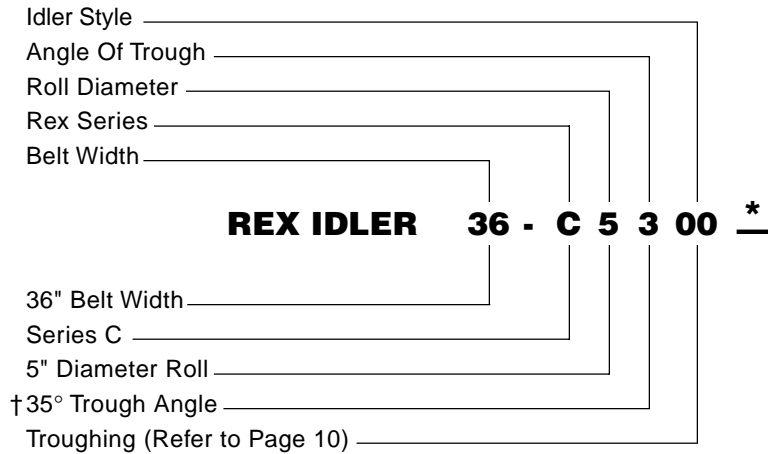

† (0 = Flat, 2 = 20°, 3 = 35°, 4 = 45°)

*** Suffix**

- | | |
|-----------------------------|------------------------------|
| C — Chevron Ribbed | S — Straight Ribbed |
| C/C — Ceramic Coated | U/C — Urethane Coated |
| C/D — Ceramic Disc | U/D — Urethane Disc |
| FS — Factory Sealed | W/B — Wide Base |
| RG — Regreasable | |

Note: Specify factory sealed or regreasable sealing option.

REX IDLERS

IDLER INTERCHANGE

Interchangeability is one of the most important features of the Rex Idler line, specifically in the dimensional areas of:

a. Backing Distance — from the bottom of the base pad to the top of the center roll of troughing idlers.

b. Bolt Hole Spacing — across the width of the conveyor frame for troughing and return idlers. (Belt width plus 9")

Rex Idlers conform to the CEMA dimensional standards and are interchangeable with competitive idlers listed below.

Manufacturer	CEMA B	CEMA C	CEMA D	CEMA E
Rexnord	Series B	Series C	Series D	Series E
Continental Conveyor	B Plus	H	H Plus	SDX
Goodman Conveyor	B	C	D	E
Hewitt-Robins	B	2000	3000	4000
FMC-Link Belt	B2000	C3000	D3000	E4000
Precismeca	PB	PC	PD	PE
Precision Idler	B	C	—	—
Stephens-Adamson	2174-2175	4205-4206	5195-5196	6326-6327
Superior Machinery	60/61/71	80/81	—	—

REX IDLERS

THE REX LINE

There is a Rex Idler to meet your service requirements ranging from intermittent conveying of light materials to continuous conveying of very heavy materials.

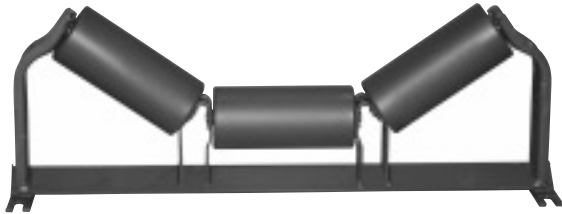

Series B

The Light Duty line exceeds CEMA B specifications using heavy duty ball bearings, available with 4" and 5" diameter rolls. Furnished in a wide selection of styles in 18" to 48" belt widths.

Available factory sealed only.

Refer Pages: 12 – 21.

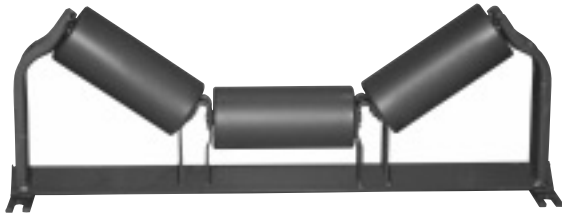

Series B+

Series B+ combines a CEMA B frame with the Rex patented "G" Seal to give longer life. Available in 4" and 5" diameter rolls. Furnished in 18"-48" belt widths.

Available in regreasable or factory sealed.

Same envelope dimensions as Series B, Pages: 12 – 21.

(Available with polyethylene rolls – B+ only.)

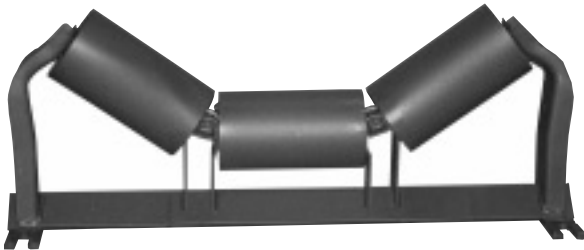

Series C

The Medium Duty line exceeds CEMA C specifications using precision tapered roller bearings, available with 5" and 6" diameter rolls. Furnished in a wide selection of styles in 18" to 60" belt widths.

Available in regreasable or factory sealed.

Refer Pages: 22 – 42

(Available with polyethylene rolls, pages 44 – 46.)

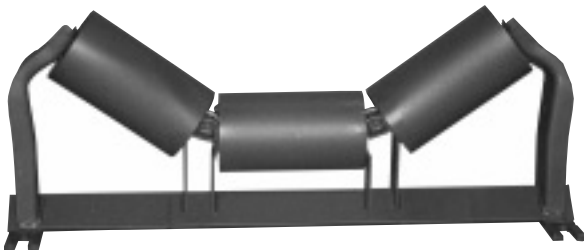

Series D

The Medium Duty line exceeds CEMA D specifications utilizing the Series C idler construction with heavier shafts to provide higher load capacity. Furnished in a wide selection of styles in 24" to 60" belt widths.

Available in regreasable or factory sealed.

Refer Pages: 22 – 42

(Available with polyethylene rolls, pages 44 – 46.)

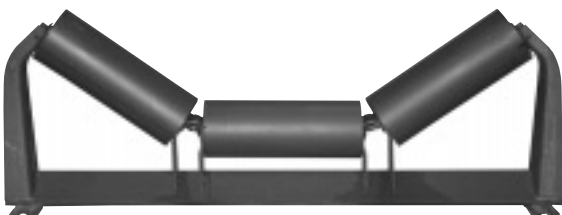

Series E

The Heavy Duty line exceeds CEMA E specifications using heavy duty precision tapered roller bearings, available with 6" and 7" diameter rolls. Furnished in a wide selection of styles in 36" to 96" belt widths.

Refer Pages: 48 – 60

REX IDLERS

THE BELT CONVEYOR

The following is a simplified conveyor, used to illustrate basic belt conveyor components. Unlimited variations of elevation, loading, discharge, idlers and idler spacing, pulleys, and accessories are possible.

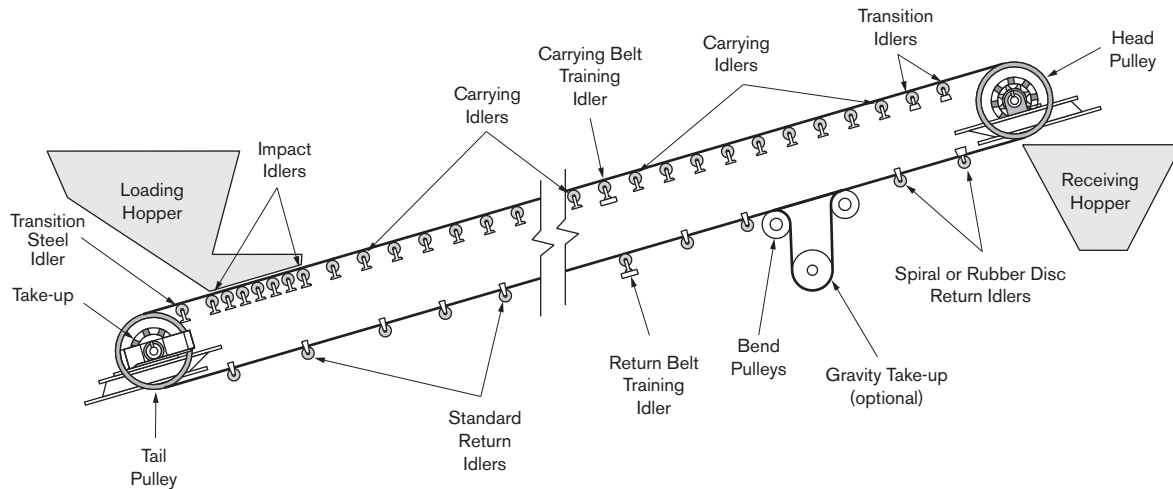

TYPES OF IDLERS

Carrying Idlers (Troughing or Flat)

Support the belt in the section of the conveyor that transports the material. These idlers may be flat or troughed to shape the belt to prevent spillage and are available in 20°, 35° and 45° trough angles with equal or unequal roll lengths. Normal spacing is 3 to 5 feet.

Refer Pages:

14, 16, 18, 24, 26, 28, 30, 32, 34, 36, 50, 52, 54, 55, 57, 61

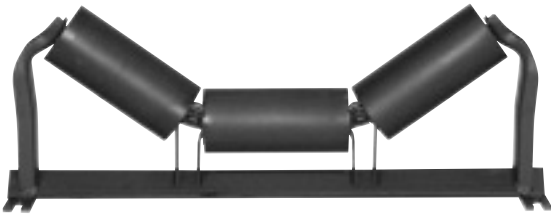

Impact Idlers (Troughing or Flat)

Prevent damage to the belt at the loading point. These idlers may be troughing or flat types with grooved, molded rubber rolls. It is standard practice to use impact idlers at all loading and transfer points when the impact force exceeds 40 foot pounds.

To insure maximum **belt protection** for optimum life and to reduce skirtboard leakage the **impact idlers** should be at least **six inch diameter** and spaced at **one foot intervals**.

Refer Pages:

14, 16, 24, 26, 28, 30, 32, 34, 36, 50, 52, 54, 55, 57, 61

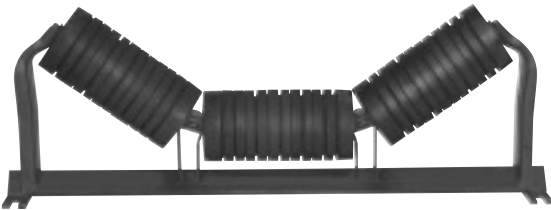

REX IDLERS

TYPES OF IDLERS

Return Idlers

Support the empty belt between the discharge point and the tail pulley. Normal spacing is 10 feet.

- a. **Steel** — Used where materials are not sticky, corrosive, or abrasive.

Available with urethane covering. Six inch diameter also available in ¼" wall thickness.

Refer Pages: 18, 36, 41, 56, 61



- b. **Spiral** — Used where sticky materials adhere to the belt, where a corrosive environment is present or abrasive wear is a problem. Unique construction minimizes belt fleet and damage to the return belt due to material build-up on the idler rolls. Spiral roll idlers can be used for belt travel in one direction only.

Refer Pages: 21, 39



- c. **Disc** — Used under the same conditions as the spiral idler. These idlers can be used for belt travel in either direction. Massed end discs are standard.

Ceramic, urethane and rubber disc rolls available.

Refer Pages: 21, 40, 56



Carrying Belt Training Idlers (Troughing or Flat)

Assist in keeping the belt centered on the conveyor. Actuating shoe type is used on belt traveling in either direction. Positive type is used on belt traveling in one direction only and is illustrated. Normal spacing is 100 feet and not within 50 feet of the head or tail pulley.

(Urethane rolls enhance trainer effectiveness.)

Refer Pages: 15, 17, 20, 25, 27, 29, 31, 33, 35, 37, 38, 51, 53, 60

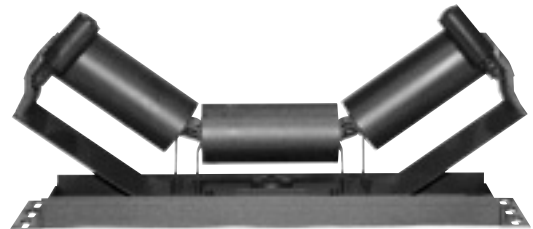

Return Belt Training Idlers

Used for the same purposes as are Carrying Training Idlers. They are of the actuating shoe type, belt travel — either direction, and the positive and inclined pivot types, belt travel — one direction only. The positive type is illustrated. Normal spacing is 100 feet and not within 50 feet of the head or tail pulley.

(Urethane rolls enhance trainer effectiveness.)

Can also be furnished with spiral or disc rolls.

Refer Pages: 19, 20, 37, 38, 39, 40, 42, 58, 59



NOTE: Ceramic and urethane covered rolls available — see page 62. Polyethylene rolls available — see pages 44 – 46.

IDLER INDEX

Idler Number	Description	Roll Diam. In.	Roll Material	Page	Idler Number	Description	Roll Diam. In.	Roll Material	Page
O3144	Return, Catenary	3	Rubber	69	B+5202	Trough Impact, 20°	5	Rubber	14
O3204	Trough, Catenary	3	Rubber	69	C5202	Trough Impact, 20°	5	Rubber	24
O4044	Return, Catenary - Solid Shaft	3-1/2	Rubber	69	D5202	Trough Impact, 20°	5	Rubber	24
B4020	Flat	4	Steel	18	C5203	Trough Impact, 20°, Unequal Roll Lg.	5	Rubber	26
B+4020	Flat	4	Steel	18	D5203	Trough Impact, 20°, Unequal Roll Lg.	5	Rubber	26
F4021	Flat, Live Shaft	4	Steel	61	C5206	Trough, 20°	5	Poly.	46
B+4030	Flat Training, Actuating Shoe	4	Steel	20	B+5210	Trough Training, 20°, Actuating Shoe	5	Steel	15
B+4031	Flat Training, Positive Arm	4	Steel	20	C5210	Trough Training, 20°, Actuating Shoe	5	Steel	25
B4040	Return	4	Steel	18	D5210	Trough Training, 20°, Actuating Shoe	5	Steel	25
B+4040	Return	4	Steel	18	C5211	Trough Training, 20°, Unequal Roll Lg.	5	Steel	27
F4041	Return, Live Shaft	4	Steel	61	D5211	Trough Training, 20°, Unequal Roll Lg.	5	Steel	27
B+4050	Return Training, Inclined Pivot	4	Steel	20	B+5212	Trough Training, 20°, Positive Arm	5	Steel	15
B+4051	Return Training, Actuating Shoe	4	Steel	19	C5212	Trough Training, 20°, Positive Arm	5	Steel	25
B+4052	Return Training, Positive Arm	4	Steel	19	D5212	Trough Training, 20°, Positive Arm	5	Steel	25
B4200	Trough, 20°	4	Steel	14	C5213	Trough Training, 20°, Positive Arm, Unequal Roll Length	5	Steel	27
B+4200	Trough, 20°	4	Steel	14	D5213	Trough Training, 20°, Positive Arm, Unequal Roll Length	5	Steel	27
B+4210	Trough Training, 20°, Actuating Shoe	4	Steel	15	C5218	Trough Training, 20°, Actuating Shoe	5	Poly.	46
B+4212	Trough Training, 20°, Positive Arm	4	Steel	15	C5264	Trough Training, 20°, Positive Arm	5	Poly.	46
B4300	Trough, 35°	4	Steel	16	B5300	Trough, 35°	5	Steel	16
B+4300	Trough, 35°	4	Steel	16	B+5300	Trough, 35°	5	Steel	16
B+4310	Trough Training, 35°, Actuating Shoe	4	Steel	17	C5300	Trough, 35°	5	Steel	28
B+4312	Trough Training, 35°, Positive Arm	4	Steel	17	D5300	Trough, 35°	5	Steel	28
B5020	Flat	5	Steel	18	C5301	Trough, 35°, Unequal Roll Length	5	Steel	30
B+5020	Flat	5	Steel	18	D5301	Trough, 35°, Unequal Roll Length	5	Steel	30
C5020	Flat	5	Steel	36	B+5302	Trough Impact, 35°	5	Rubber	16
D5020	Flat	5	Steel	36	C5302	Trough Impact, 35°	5	Rubber	28
C5021	Flat, Live Shaft	6	Steel	61	D5302	Trough Impact, 35°	5	Rubber	28
F5022	Flat, Impact Live Shaft	5	Rubber	61	C5303	Trough Impact, 35°, Unequal Roll Lg.	5	Rubber	30
C5025	Flat, Impact	5	Rubber	36	D5303	Trough Impact, 35°, Unequal Roll Lg.	5	Rubber	30
D5025	Flat, Impact	5	Rubber	36	C5306	Trough, 35°	5	Poly.	46
C5027	Flat	5	Poly.	46	B+5310	Trough Training, 35°, Actuating Shoe	5	Steel	17
B+5030	Flat Training, Actuating Shoe	5	Steel	20	C5310	Trough Training, 35°, Actuating Shoe	5	Steel	29
C5030	Flat Training, Actuating Shoe	5	Steel	38	D5310	Trough Training, 35°, Actuating Shoe	5	Steel	29
D5030	Flat Training, Actuating Shoe	5	Steel	38	C5311	Trough Training, 35°, Actuating Shoe, Unequal Roll Length	5	Steel	31
B+5031	Flat Training, Positive Arm	5	Steel	20	D5311	Trough Training, 35°, Actuating Shoe, Unequal Roll Length	5	Steel	31
C5031	Flat Training, Positive Arm	5	Steel	37	B+5312	Trough Training, 35°, Positive Arm	5	Steel	17
D5031	Flat Training, Positive Arm	5	Steel	37	C5312	Trough Training, 35°, Positive Arm	5	Steel	29
C5035	Flat Training, Actuating Shoe	5	Poly.	46	D5312	Trough Training, 35°, Positive Arm	5	Steel	29
C5036	Flat Training, Positive Arm	5	Poly.	46	C5313	Trough Training, 35°, Positive Arm, Unequal Roll Length	5	Steel	31
B5040	Return	5	Steel	18	D5313	Trough Training, 35°, Positive Arm, Unequal Roll Length	5	Steel	31
B+5040	Return	5	Steel	18	C5318	Trough Training, 35°, Actuating Shoe	5	Poly.	46
C5040	Return	5	Steel	36	C5364	Trough Training, 35°, Positive Arm	5	Poly.	46
F5041	Return, Live Shaft	5	Steel	61	C5400	Trough, 45°	5	Steel	32
B5043	Return, Disc	5	Rubber	21	D5400	Trough, 45°	5	Steel	32
B+5043	Return, Disc	5	Rubber	21	C5401	Trough, 45°, Unequal Roll Length	5	Steel	34
C5043	Return, Disc	5	Rubber	40	D5401	Trough, 45°, Unequal Roll Length	5	Steel	34
D5043	Return, Disc	5	Rubber	40	C5402	Trough Impact, 45°	5	Rubber	32
C5045	Return	5	Rubber	36	D5402	Trough Impact, 45°	5	Rubber	32
D5045	Return	5	Rubber	36	C5403	Trough Impact, 45°, Unequal Roll Lg.	5	Rubber	34
C5046	Return, Ribbed Covered	6-1/2	Rubber	41	D5403	Trough Impact, 45°, Unequal Roll Lg.	5	Rubber	34
D5046	Return, Ribbed Covered	6-1/2	Rubber	41	C5406	Trough, 45°	5	Poly.	46
C5047	Return	5	Poly.	46	C5410	Trough Training, 45°, Actuating Shoe	5	Steel	33
B+5050	Return Training, Inclined Pivot	5	Steel	20	D5410	Trough Training, 45°, Actuating Shoe	5	Steel	33
C5050	Return Training, Inclined Pivot	5	Steel	38	C5411	Trough Training, 45°, Actuating Shoe, Unequal Roll Length	5	Steel	35
D5050	Return Training, Inclined Pivot	5	Steel	38	D5411	Trough Training, 45°, Actuating Shoe, Unequal Roll Length	5	Steel	35
B+5051	Return Training, Actuating Shoe	5	Steel	19	C5412	Trough Training, 45°, Positive Arm	5	Steel	33
C5051	Return Training, Actuating Shoe	5	Steel	38	D5412	Trough Training, 45°, Positive Arm	5	Steel	33
D5051	Return Training, Actuating Shoe	5	Steel	38	C5413	Trough Training, 45°, Positive Arm, Unequal Roll Length	5	Steel	35
B+5052	Return Training, Positive Arm	5	Steel	19	D5413	Trough Training, 45°, Positive Arm, Unequal Roll Length	5	Steel	35
C5052	Return Training, Positive Arm	5	Steel	37	C5418	Trough Training, 45°, Actuating Shoe	5	Poly.	46
D5052	Return Training, Positive Arm	5	Steel	37	C5464	Trough Training, 45°, Positive Arm	5	Poly.	46
C5054	Return Training, Disc, Inclined Pivot	5	Rubber	40	C6020	Flat	6	Steel	36
D5054	Return Training, Disc, Inclined Pivot	5	Rubber	40					
C5056	Return Training, Disc, Positive Arm	5	Rubber	40					
D5056	Return Training, Disc, Positive Arm	5	Rubber	40					
C5059	Return Training, Positive Arm	5	Poly.	46					
C5070	Return Training, Actuating Shoe	5	Poly.	46					
B5200	Trough, 20°	5	Steel	14					
B+5200	Trough, 20°	5	Steel	14					
C5200	Trough, 20°	5	Steel	24					
D5200	Trough, 20°	5	Steel	24					
C5201	Trough, 20°, Unequal Roll Length	5	Steel	26					
D5201	Trough, 20°, Unequal Roll Length	5	Steel	26					

IDLER INDEX

Idler Number	Description	Roll Diam. In.	Roll Material	Page	Idler Number	Description	Roll Diam. In.	Roll Material	Page
D6020	Flat	6	Steel	36	D6213	Trough Training, 20°, Positive Arm, Unequal Roll Length	6	Steel	27
E6020	Flat	7	Steel	57	C6218	Trough Training, 20°, Actuating Shoe	6	Poly.	46
F6021	Flat, Live Shaft	6	Steel	61	C6264	Trough Training, 20°, Positive Arm	6	Poly.	46
F6022	Flat, Impact Live Shaft	6	Rubber	61	C6300	Trough, 35°	6	Steel	28
C6025	Flat, Impact	6	Rubber	36	D6300	Trough, 35°	6	Steel	28
D6025	Flat, Impact	6	Rubber	36	E6300	Trough, 35°	6	Steel	52
E6025	Flat, Impact	6	Rubber	57	C6301	Trough, 35°, Unequal Roll Length	6	Steel	30
C6027	Flat	6	Poly.	46	D6301	Trough, 35°, Unequal Roll Length	6	Steel	30
C6030	Flat Training, Actuating Shoe	6	Steel	38	C6302	Trough Impact, 35°	6	Rubber	28
D6030	Flat Training, Actuating Shoe	6	Steel	38	D6302	Trough Impact, 35°	6	Rubber	28
C6031	Flat Training, Positive Arm	6	Steel	37	C6303	Trough Impact, 35°, Unequal Roll Lg.	6	Rubber	30
D6031	Flat Training, Positive Arm	6	Steel	37	D6303	Trough Impact, 35°, Unequal Roll Lg.	6	Rubber	30
C6035	Flat Training, Actuating Shoe	6	Poly.	46	C6306	Trough, 35°	6	Poly.	46
D6035	Flat Training, Actuating Shoe	6	Poly.	46	C6310	Trough Training, 35°, Actuating Shoe	6	Steel	29
D6036	Flat Training, Positive Arm	6	Poly.	46	D6310	Trough Training, 35°, Actuating Shoe	6	Steel	29
C6040	Return	6	Steel	36	E6310	Trough Training, 35°, Actuating Shoe	6	Steel	53
D6040	Return	6	Steel	36	C6311	Trough Training, 35°, Actuating Shoe, Unequal Roll Length	6	Steel	31
E6040	Return	6	Steel	56	D6311	Trough Training, 35°, Actuating Shoe, Unequal Roll Length	6	Steel	31
F6041	Return, Live Shaft	6	Steel	61	C6312	Trough Training, 35°, Positive Arm	6	Steel	29
C6042	Return, Spiral	5-1/2	Rubber	39	D6312	Trough Training, 35°, Positive Arm	6	Steel	29
D6042	Return, Spiral	5-1/2	Rubber	39	E6312	Trough Training, 35°, Positive Arm	6	Steel	53
C6043	Return, Disc	6	Rubber	40	C6313	Trough Training, 35°, Positive Arm, Unequal Roll Length	6	Steel	35
D6043	Return, Disc	6	Rubber	40	D6313	Trough Training, 35°, Positive Arm, Unequal Roll Length	6	Steel	35
E6043	Return, Disc	6	Rubber	56	C6318	Trough Training, 35°, Actuating Shoe	6	Poly.	46
C6045	Return	6	Rubber	36	C6364	Trough Training, 35°, Positive Arm	6	Poly.	46
D6045	Return	6	Rubber	36	C6400	Trough, 45°	6	Steel	32
C6046	Return, Ribbed Covered	7-1/2	Rubber	41	D6400	Trough, 45°	6	Steel	32
D6046	Return, Ribbed Covered	7-1/2	Rubber	41	C6401	Trough, 45°, Unequal Roll Length	6	Steel	34
C6047	Return	6	Poly.	46	D6401	Trough, 45°, Unequal Roll Length	6	Steel	34
C6050	Return Training, Inclined Pivot	6	Steel	38	C6402	Trough Impact, 45°	6	Rubber	32
D6050	Return Training, Inclined Pivot	6	Steel	38	D6402	Trough Impact, 45°	6	Rubber	32
C6051	Return Training, Actuating Shoe	6	Steel	38	C6403	Trough Impact, 45°, Unequal Roll Lg.	6	Rubber	34
D6051	Return Training, Actuating Shoe	6	Steel	38	D6403	Trough Impact, 45°, Unequal Roll Lg.	6	Rubber	34
E6051	Return Training, Actuating Shoe	6	Steel	59	C6406	Trough, 45°	6	Poly.	46
C6052	Return Training, Positive Arm	6	Steel	37	C6410	Trough Training, 45°, Actuating Shoe	6	Steel	35
D6052	Return Training, Positive Arm	6	Steel	58	D6410	Trough Training, 45°, Actuating Shoe	6	Steel	33
E6052	Return Training, Positive Arm	6	Steel	58	C6411	Trough Training, 45°, Actuating Shoe, Unequal Roll Length	6	Steel	35
C6053	Return Training, Spiral, Inc. Pivot	5-1/2	Rubber	39	D6411	Trough Training, 45°, Actuating Shoe, Unequal Roll Length	6	Steel	35
D6053	Return Training, Spiral, Inc. Pivot	5-1/2	Rubber	39	C6412	Trough Training, 45°, Positive Arm	6	Steel	33
C6054	Return Training, Disc, Inclined Pivot	6	Rubber	40	D6412	Trough Training, 45°, Positive Arm	6	Steel	33
D6054	Return Training, Disc, Inclined Pivot	6	Rubber	40	C6413	Trough Training, 45°, Positive Arm, Unequal Roll Length	6	Steel	35
C6056	Return Training, Disc, Positive Arm	6	Rubber	40	D6413	Trough Training, 45°, Positive Arm, Unequal Roll Length	6	Steel	35
D6056	Return Training, Disc, Positive Arm	6	Rubber	40	C6418	Trough Training, 45°, Actuating Shoe	6	Poly.	46
E6056	Return Training, Disc, Positive Arm	6	Rubber	58	C6464	Trough Training, 45°, Positive Arm	6	Poly.	46
C6057	Return Training, Spiral, Positive Arm	5-1/2	Rubber	39	E7020	Flat	7	Steel	57
D6057	Return Training, Spiral, Positive Arm	5-1/2	Rubber	39	E7021	Flat, Live Shaft	7	Steel	61
D6058	Return Training, Ribbed	7-1/2	Rubber	42	F7022	Flat, Impact Live Shaft	7	Rubber	61
C6059	Return Training, Positive Arm	6	Poly.	46	E7025	Flat, Impact	7	Rubber	57
C6070	Return Training, Actuating Shoe	6	Poly.	46	E7040	Return	7	Steel	56
C6200	Trough, 20°	6	Steel	24	E7041	Return, Live Shaft	7	Steel	61
D6200	Trough, 20°	6	Steel	24	E7043	Return, Disc	7	Rubber	56
E6200	Trough, 20°	6	Steel	55	E7046	Return, Beater	7	Rod	60
C6201	Trough, 20°, Unequal Roll Length	6	Steel	26	E7051	Return Training, Actuating Shoe	7	Steel	59
D6201	Trough, 20°, Unequal Roll Length	6	Steel	26	E7052	Return Training, Positive Arm	7	Steel	58
C6202	Trough Impact, 20°	6	Rubber	24	E7056	Return Training, Disc., Positive Arm	7	Rubber	58
D6202	Trough Impact, 20°	6	Rubber	24	E7200	Trough, 20°	7	Steel	50
C6203	Trough Impact, 20°, Unequal Roll Lg.	6	Rubber	26	E7202	Trough, Impact, 20°	7	Rubber	50
D6203	Trough Impact, 20°, Unequal Roll Lg.	6	Rubber	26	E7210	Trough Training, 20°, Actuating Shoe	7	Steel	51
C6206	Trough, 20°	6	Poly.	46	E7212	Trough Training, 20°, Positive Arm	7	Steel	51
C6210	Trough Training, 20°, Actuating Shoe	6	Steel	25	E7300	Trough, 35°	7	Steel	52
D6210	Trough Training, 20°, Actuating Shoe	6	Steel	25	E7302	Trough Impact, 35°	7	Rubber	52
E6210	Trough Training, 20°, Actuating Shoe	6	Steel	51	E7310	Trough Training 35°, Actuating Shoe	7	Steel	53
C6211	Trough Training, 20°, Actuating Shoe, Unequal Roll Length	6	Steel	27	E7312	Trough Training 35°, Positive Arm	7	Steel	53
D6211	Trough Training, 20°, Actuating Shoe, Unequal Roll Length	6	Steel	27					
C6212	Trough Training, 20°, Positive Arm	6	Steel	25					
D6212	Trough Training, 20°, Positive Arm	6	Steel	25					
E6212	Trough Training, 20°, Positive Arm	6	Steel	51					
C6213	Trough Training, 20°, Positive Arm, Unequal Roll Length	6	Steel	27					

IDLER INDEX

IDLER STYLES AND PAGE LOCATION

Style No. (Last 2 Digits)	Idler Description			PAGE NUMBER										
				Series										
	Type	Roll		B and B+			C & D				E			
				Angle of Trough										
	Material	Length	0°	20°	35°	0°	20°	35°	45°	0°	20°	35°	45°	
00	Troughing	Steel	Equal	...	14	16	...	24	28	32	...	50	52	...
01	Troughing	Steel	Unequal	27	31	35
02	Troughing Impact	Rubber	Equal	...	14	16	...	24	28	32	...	50	52	...
03	Troughing Impact	Rubber	Unequal	26	30	34
04	Troughing, Catenary - 25°	Rubber
06	Troughing	Poly-ethylene	Equal	46	46	46
10	Troughing Training, Actuating Shoe	Steel	Equal	...	15	17	...	25	29	33	...	51	53	...
11	Troughing Training, Actuating Shoe	Steel	Unequal	27	31	35
12	Troughing Training, Positive Arm	Steel	Equal	...	15	17	...	25	29	33	...	51	53	...
13	Troughing Training, Positive Arm	Steel	Unequal	27	31	35
18	Troughing Training, Actuating Shoe	Poly-ethylene	Equal	46	46	46
20	Flat	Steel	...	18	36	57
21	Flat, Live Shaft (order as 41)	Steel	61
22	Flat, Impact Live Shaft	Rubber	61	61
25	Flat, Impact	Rubber	36	57
27	Flat	Poly-ethylene	46
30	Flat, Training, Actuating Shoe	Steel	...	20	38
31	Flat, Training, Positive Arm	Steel	...	20	37	60
35	Flat, Training, Actuating Shoe	Poly-ethylene	46
36	Flat, Training, Positive Arm	Poly-ethylene	46
40	Return	Steel	...	18	36	57
41	Return, Live Shaft	Steel	61
42	Return, Spiral	Rubber	39
43	Return, Disc	Rubber	...	21	40	56
44	Return, Catenary	Rubber
45	Return	Rubber	36
46	Return, Ribbed (C or S)	Rubber	41
46	Return, Beater, Rod	Steel (E)	60
47	Return	Poly-ethylene	46
49	Return, Impact	Rubber	36
50	Return Training, Inclined Pivot	Steel	...	20	38
51	Return Training, Actuating Shoe	Steel	...	19	38	59
52	Return Training, Positive Arm	Steel	...	19	37	58
53	Return Training, Spiral, Inclined Pivot	Rubber	39
54	Return Training, Disc, Inclined Pivot	Rubber	40
55	Return Training, Disc, Actuating Shoe	Rubber	59
56	Return Training, Disc, Positive Arm	Rubber	40	58
57	Return Training Spiral, Positive Arm	Rubber	39
58	Return Training, Ribbed	Rubber	42
59	Return Training, Positive Arm	Poly-ethylene	46
64	Troughing Training, Positive Arm	Poly-ethylene	Equal	46
70	Return Training, Actuating Shoe	Poly-ethylene	46

REX IDLER SEALS

SEAL FEATURES OF B, B+, C AND D

FACTORY SEALED: B SERIES has a 17mm “Sealed For Life” ball bearing protected by metal and polymeric covers.

A SPECIAL COMBINATION LABYRINTH AND OUTER SHIELD: B+, C AND D SERIES

REGREASABLE and **FACTORY SEALED** — The seal has a (5) passage labyrinth with a wiping component — filled with grease to block contaminants from reaching the bearing. The inner and outer seals are close tolerance, injection molded non-metallic components to retard corrosion. The labyrinth and rear seal retain the lubrication within the bearing cavity. The protective outer shield provides an additional barrier to further delay the penetration of contaminants.

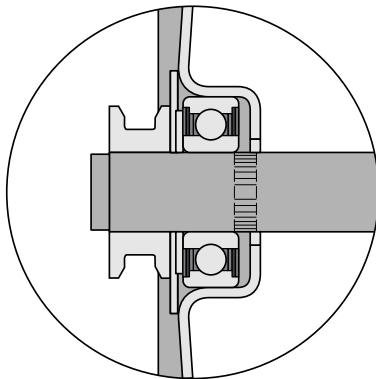

SERIES B
BALL BEARING
FACTORY SEALED

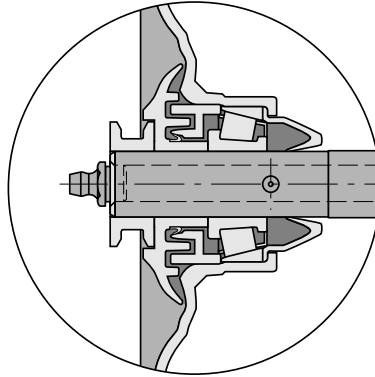

SERIES B+, C
ROLLER BEARING
REGREASABLE

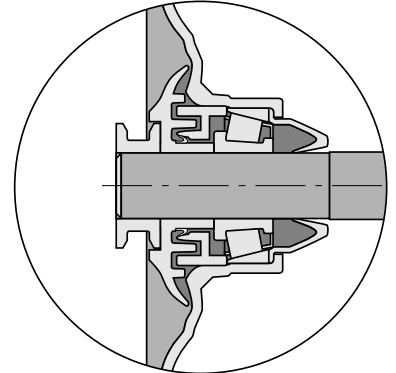

SERIES B+, C
ROLLER BEARING
FACTORY SEALED

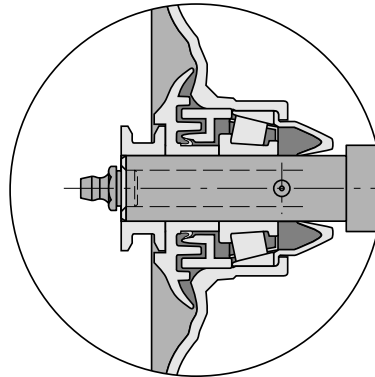

SERIES D
ROLLER BEARING
REGREASABLE

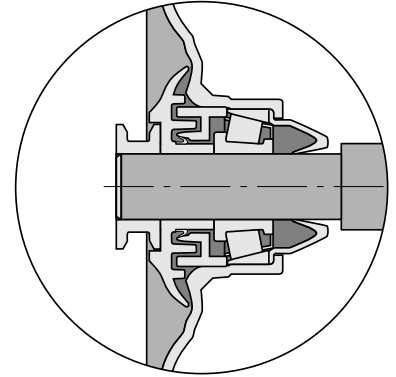

SERIES D
ROLLER BEARING
FACTORY SEALED

REGREASABLE

Regreasable idlers with the unique labyrinth/shield design are excellent for long overland conveyors. For installations where water is present or where frequent washdowns are required, regreasing is recommended.

Periodic regreasing will flush the bearings and seals of contaminants to provide extended roll life.

FACTORY SEALED

Factory sealed idlers with the same seal design and a solid shaft are a viable economic alternative for those installations where periodic regreasing will not be provided.

REX IDLERS

ECONO-B Series – CEMA B Factory Sealed 20° and 35° Trough – 4" and 5" Roll Diameter – 17 mm Solid Shaft

Longer Belt and Idler Life

The ECONO-B is the economical choice for light to moderate duty. A factory sealed ball bearing designed for optimum idler life means no lubrication is necessary.

Factory Sealed Idlers

Sealed-for-life by the "H" seal. Metal and polymeric covers protect the sealed bearing for longer life...
B Series.

Longer Idler Life

Rugged ball bearings and 17 mm diameter shafts provide ample load-carrying capacity ...
B Series.

A Rexnord exclusive manufacturing process

produces a unique rounded roll end. This EASY Roll protects the belt for longer life. The EASY Roll design also keeps the roll shell and end disc junction completely away from the wear area for more idler life. Meets or exceeds CEMA load rating requirements.

Longer Belt Life

Rex designed "Mini-Gap" provides smallest possible space between rollers for maximum "no pinch" belt protection... better belt support and longer belt life... **B and B+ Series.**

Roll Gap Rex Series B and B+

Roll Diameter Inches	Trough Angle	
	20°	35°
4	1/2"	17/32"
5	9/32"	5/16"

4" and 5" Diameter Roll Thickness

9 gauge (.149") increased roll life ... **B and B+ Series.**

Withstands Rough Handling

Rolls stay in proper position during shipment and installation, yet are easily removed to provide fast liftout roll replacement... **B and B+ Series.**

Interchangeability

...built to fit existing conveyor frame without cutting or fitting. Conforms to CEMA B dimensions... **B and B+ Series.**

Self-Cleaning Base

Inverted angle base prevents build-up of spillage... eliminates possible jamming of idler rolls... **B and B+ Series.**

Series B – CEMA B Idlers – 17 mm Solid Shaft – Factory Sealed Only

REX IDLERS

Series B+ – FACTORY SEALED or REGREASABLE 20° and 35° Trough – 4" and 5" Roll Diameter – 3/4" Shaft

More Capacity with an Option of Relubrication

The Rex B+ offers a tapered roller bearing and the patented "G" seal in the same envelope dimensions as the Series B. Available as factory sealed with solid shaft or regreasable. Exceeds CEMA load rating requirements.

Reduced Maintenance Costs

Positive, easy, convenient one point greasing, from either side, makes sure all bearings receive the proper amount of grease... saves time and grease... **B+ Series.**

Less Vibration

Uniform wall shells are assembled to precision-drawn end discs to form a rugged, integral roll assembly. Ends are simultaneously counterbored to provide true concentric rotation for smooth operation... **B and B+ Series.**

Extended Bearing Life

The patented "G" seal incorporates a rear sealing system that maintains pressure in the bearing cavity yet allows excess grease to purge, preventing bearing/seal damage... **B+ Series.**

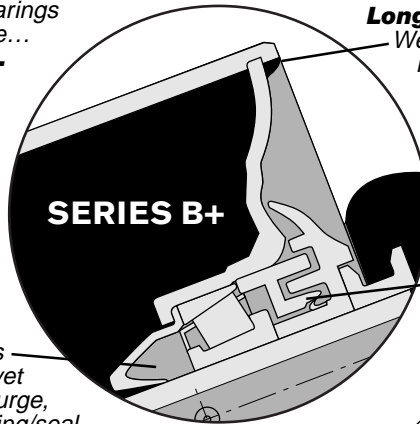

Longer Belt and Roll Life

Weld bead is located under the roll shell. No belt contact ... no wear... **B+ Series.**

Protection

Factory Sealed and Regreasable Idlers utilize the patented "G" seal which is a combination 5 passage horizontal labyrinth with positive wiper and outer shield. Excellent protection against abrasives and moisture... **B+ Series.**

Longer Idler Life

3/4" shaft with tapered roller bearings provide extra load carrying capacity ... **B+ Series.**

Total Indicated Roll Runout is .030" ... B and B+ Series.

Handles Surge Loading

Die formed, deep-pressed end brackets welded to inverted angle base assure rugged structural strength to prevent distortion... **B and B+ Series.**

	Roll Diameter
Polyethylene*	5"
Ceramic	4, 5"
Urethane	4, 5"
Rubber	4, 5"

*Options available in B+ only.

Note:

Grease transfer tube on regreasable idler only ... **B+ Series.**

Simple Belt Training Adjustment

of idlers is fast and easy using slotted mounting holes. Precision jig welded frame assures positive, accurate alignment... **B and B+ Series.**

Series B+ Idlers – 3/4" Shaft – Factory Sealed or Regreasable

REX IDLERS

SERIES B and B+

20° TROUGHING IDLER — EQUAL LENGTH ROLLS

REGREASABLE FACTORY SEALED

B+4200 RG B4200 FS
B+4200 FS

4-Inch Steel Rolls

B+5200 RG B5200 FS
B+5200 FS

5-Inch Steel Rolls

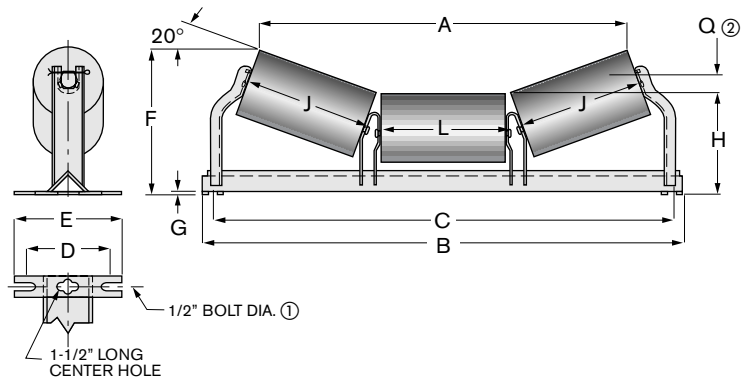

Dimensions in Inches — Average Weight in Pounds

Belt Width	A		B	C	D		E	F		G	H		J	L	Q	Idler Wgt.	
	4" Roll	5" Roll			Recom.	Minimum		4" Roll	5" Roll		4" Roll	5" Roll				4" Roll	5" Roll
18	21 ¹ / ₁₆	20 ³ / ₄	28 ¹ / ₂	27	6	5 ³ / ₈	7 ³ / ₄	9 ⁵ / ₁₆	9 ³ / ₄	1/4	6 ¹ / ₁₆	7 ⁵ / ₁₆	7	7	1 ⁵ / ₁₆	28	31
20	23 ¹ / ₁₆	22 ³ / ₄	30 ¹ / ₂	29	6	5 ³ / ₈	7 ³ / ₄	9 ⁹ / ₁₆	9 ³ / ₄	1/4	6 ¹ / ₁₆	7 ⁵ / ₁₆	7	9	1 ⁹ / ₁₆	29	33
24	26 ¹ / ₁₆	26 ¹ / ₂	34 ¹ / ₂	33	6	5 ³ / ₈	7 ³ / ₄	10	10 ¹ / ₂	1/4	6 ¹ / ₁₆	7 ⁵ / ₁₆	9	9	1 ¹ / ₄	33	37
30	32 ⁵ / ₈	32 ¹ / ₄	40 ¹ / ₂	39	6	5 ³ / ₈	7 ³ / ₄	10 ¹ / ₁₆	11 ¹ / ₈	1/4	6 ¹ / ₁₆	7 ⁵ / ₁₆	11	11	1 ⁹ / ₁₆	38	43
36	38 ³ / ₈	38	47	45	7 ¹ / ₂	5 ³ / ₄	9 ¹ / ₄	11 ³ / ₄	12 ¹ / ₄	5/16	7 ¹ / ₄	7 ³ / ₄	13	13	1 ¹ / ₁₆	47	53
42	44 ¹ / ₈	43 ³ / ₄	53	51	7 ¹ / ₂	5 ³ / ₄	9 ¹ / ₄	12 ¹ / ₂	12 ¹ / ₁₆	5/16	7 ¹ / ₄	7 ³ / ₄	15	15	2 ¹ / ₄	52	59
48	49 ⁷ / ₈	49 ¹ / ₂	59	57	7 ¹ / ₂	5 ³ / ₄	9 ¹ / ₄	13 ¹ / ₈	13 ³ / ₈	5/16	7 ¹ / ₄	7 ³ / ₄	17	17	2 ⁵ / ₈	58	66

① Use washers with 1/2" bolts.

□ Shaded sizes are most commonly used and are more readily available.

② Location of head pulley in relation to idler center roll.

20° TROUGHING IMPACT IDLER — EQUAL LENGTH ROLLS

REGREASABLE FACTORY SEALED

B+5202 RG B+5202 FS

5-Inch Rubber Rolls

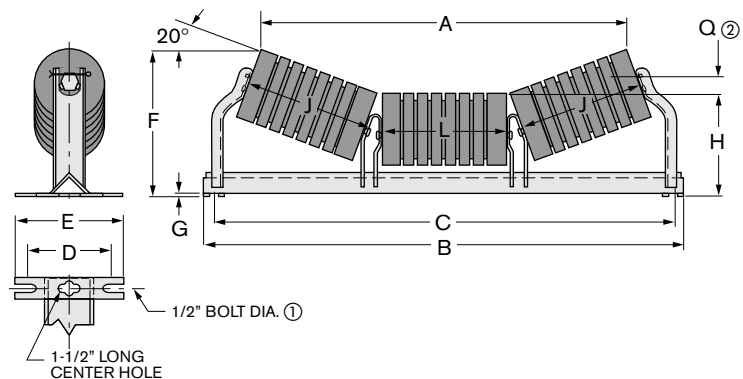

Dimensions in Inches — Average Weight in Pounds

Belt Width	A	B	C	D		E	F	G	H	J	L	Q	Idler Wgt.
				Recom.	Minimum								
18	20 ⁵ / ₈	28 ¹ / ₈	27	6	5 ³ / ₈	7 ³ / ₄	9 ³ / ₄	1/4	7 ⁵ / ₁₆	7	7	1 ⁵ / ₁₆	37
20	22 ⁵ / ₈	30 ¹ / ₂	29	6	5 ³ / ₈	7 ³ / ₄	9 ³ / ₄	1/4	7 ⁵ / ₁₆	7	9	1 ⁵ / ₁₆	39
24	26 ¹ / ₂	34 ¹ / ₂	33	6	5 ³ / ₈	7 ³ / ₄	10 ¹ / ₂	1/4	7 ⁵ / ₁₆	9	9	1 ¹ / ₄	41
30	32 ³ / ₁₆	40 ¹ / ₂	39	6	5 ³ / ₈	7 ³ / ₄	11 ¹ / ₈	1/4	7 ⁵ / ₁₆	11	11	1 ⁹ / ₁₆	57
36	37 ¹ / ₁₆	47	45	7 ¹ / ₂	5 ³ / ₄	9 ¹ / ₄	12 ¹ / ₄	5/16	7 ³ / ₄	13	13	1 ¹ / ₁₆	65
42	43 ¹ / ₁₆	53	51	7 ¹ / ₂	5 ³ / ₄	9 ¹ / ₄	12 ¹ / ₁₆	5/16	7 ³ / ₄	15	15	2 ¹ / ₄	74
48	49 ⁷ / ₁₆	59	57	7 ¹ / ₂	5 ³ / ₄	9 ¹ / ₄	13 ³ / ₈	5/16	7 ³ / ₄	17	17	2 ⁵ / ₈	87

① Use washers with 1/2" bolts.

□ Shaded sizes are most commonly used and are more readily available.

② Location of head pulley in relation to idler center roll.

Note: Dimensions subject to change. Certified drawings are supplied with orders upon request.

REX IDLERS

SERIES B+

20° TROUGHING TRAINING IDLER — EQUAL LENGTH ROLLS

Positive Arm^① Type — Belt Travel One Direction Only

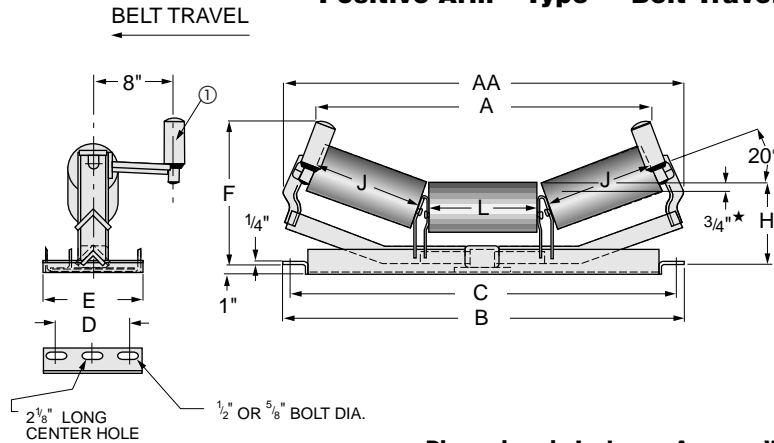

REGREASABLE FACTORY SEALED

B+4212 RG **B+4212 FS**
4-Inch Steel Rolls

B+5212 RG **B+5212 FS**
5-Inch Steel Rolls

Dimensions in Inches — Average Weight in Pounds

Belt Width	A	AA	B	C	D			E	F	H		J	L	Idler Wgt.	
					Recom.	Minimum	Maximum			4" Roll	5" Roll			4" Roll	5" Roll
18	23 ³ / ₁₆	28 ⁹ / ₁₆	28 ¹ / ₂	27	7 ¹ / ₂	5 ³ / ₄	8 ⁵ / ₈	10	13 ³ / ₈	7 ⁵ / ₈	8 ¹ / ₈	7	7	75	80
20	25 ³ / ₁₆	30 ⁹ / ₁₆	30 ¹ / ₂	29	7 ¹ / ₂	5 ³ / ₄	8 ⁵ / ₈	10	13 ³ / ₈	7 ⁵ / ₈	8 ¹ / ₈	7	9	78	84
24	28 ¹⁵ / ₁₆	34 ³ / ₁₆	34 ¹ / ₂	33	7 ¹ / ₂	5 ³ / ₄	8 ⁵ / ₈	10	14	7 ⁵ / ₈	8 ¹ / ₈	9	9	81	87
30	34 ¹ / ₁₆	40 ¹ / ₁₆	40 ¹ / ₂	39	7 ¹ / ₂	5 ³ / ₄	8 ⁵ / ₈	10	14 ¹¹ / ₁₆	7 ⁵ / ₈	8 ¹ / ₈	11	11	102	110
36	40 ¹ / ₂	45 ⁷ / ₁₆	46 ¹ / ₂	45	7 ¹ / ₂	5 ³ / ₄	8 ⁵ / ₈	10	15 ⁷ / ₁₆	7 ⁵ / ₈	8 ¹ / ₈	13	13	111	120
42	46 ¹ / ₄	51 ¹³ / ₁₆	52 ¹ / ₂	51	7 ¹ / ₂	5 ³ / ₄	10 ³ / ₄	14 ¹ / ₂	16 ⁷ / ₁₆	8	8 ¹ / ₂	15	15	121	132
48	52	57 ⁹ / ₁₆	58 ¹ / ₂	57	7 ¹ / ₂	5 ³ / ₄	10 ³ / ₄	14 ¹ / ₂	17 ¹ / ₈	8	8 ¹ / ₂	17	17	132	144

★ Approximate distance to the top of the center roll of other idlers.

□ Shaded sizes are most commonly used and are more readily available.

20° TROUGHING TRAINING IDLER — EQUAL LENGTH ROLLS

Actuating Shoe^① Type — Belt Travel Either Direction

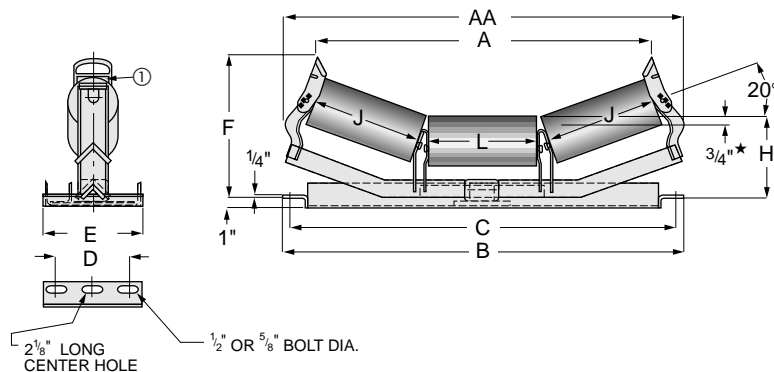

REGREASABLE FACTORY SEALED

B+4210 RG **B+4210 FS**
4-Inch Steel Rolls

B+5210 RG **B+5210 FS**
5-Inch Steel Rolls

Dimensions in Inches — Average Weight in Pounds

Belt Width	A	AA	B	C	D			E	F	H		J	L	Idler Wgt.	
					Recom.	Minimum	Maximum			4" Roll	5" Roll			4" Roll	5" Roll
18	23 ³ / ₄	28 ⁹ / ₁₆	28 ¹ / ₂	27	7 ¹ / ₂	5 ³ / ₄	8 ⁵ / ₈	10	12 ¹ / ₁₆	7 ⁵ / ₈	8 ¹ / ₈	7	7	75	80
20	25 ³ / ₄	30 ⁹ / ₁₆	30 ¹ / ₂	29	7 ¹ / ₂	5 ³ / ₄	8 ⁵ / ₈	10	12 ¹ / ₁₆	7 ⁵ / ₈	8 ¹ / ₈	7	9	78	84
24	29 ³ / ₄	34 ³ / ₁₆	34 ¹ / ₂	33	7 ¹ / ₂	5 ³ / ₄	8 ⁵ / ₈	10	12 ³ / ₄	7 ⁵ / ₈	8 ¹ / ₈	9	9	81	87
30	35 ¹ / ₄	40 ¹ / ₁₆	40 ¹ / ₂	39	7 ¹ / ₂	5 ³ / ₄	8 ⁵ / ₈	10	13 ⁷ / ₈	7 ⁵ / ₈	8 ¹ / ₈	11	11	102	110
36	41	45 ⁷ / ₁₆	46 ¹ / ₂	45	7 ¹ / ₂	5 ³ / ₄	8 ⁵ / ₈	10	14 ¹ / ₁₆	7 ⁵ / ₈	8 ¹ / ₈	13	13	111	120
42	46 ³ / ₄	51 ¹³ / ₁₆	52 ¹ / ₂	51	7 ¹ / ₂	5 ³ / ₄	10 ³ / ₄	14 ¹ / ₂	15 ³ / ₁₆	8	8 ¹ / ₂	15	15	121	132
48	52 ¹ / ₂	57 ⁹ / ₁₆	58 ¹ / ₂	57	7 ¹ / ₂	5 ³ / ₄	10 ³ / ₄	14 ¹ / ₂	15 ⁷ / ₈	8	8 ¹ / ₂	17	17	132	144

★ Approximate distance to the top of the center roll of other idlers.

□ Shaded sizes are most commonly used and are more readily available.

Note: Dimensions subject to change. Certified drawings are supplied with orders upon request.

REX IDLERS

SERIES B and B+

35° TROUGHING IDLER — EQUAL LENGTH ROLLS

REGREASABLE FACTORY SEALED

B+4300 RG **B4300 FS**
B+4300 FS

4-Inch Steel Rolls

B+5300 RG **B5300 FS**
B+5300 FS

5-Inch Steel Rolls

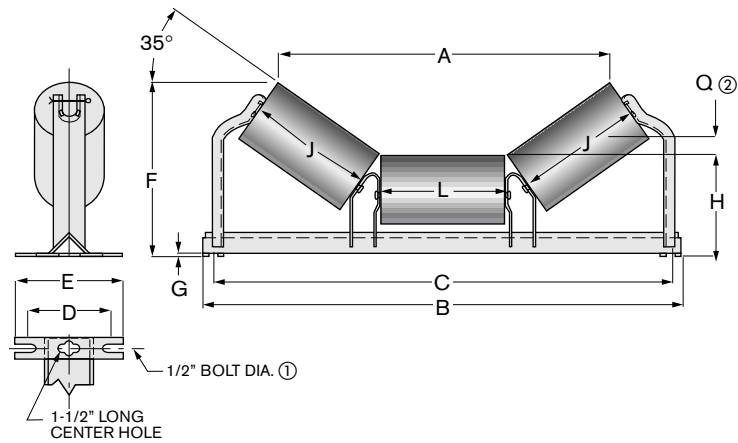

Dimensions in Inches — Average Weight in Pounds

Belt Width	A		B	C	D		E	F		G	H		J	L	Q	Idler Wgt.			
	4" Roll	5" Roll			Recom.	Minimum		4" Roll	5" Roll		4" Roll	5" Roll				4" Roll	5" Roll	4" Roll	5" Roll
18	19½	18⅞	28½	27	6	5⅝	7¾	11	11⅞	¼	6⅜	7⅞	7	7	1½	28	32		
20	21½	20⅞	30½	29	6	5⅝	7¾	11	11⅞	¼	6⅜	7⅞	7	9	1½	30	34		
24	24¾	24⅜	34½	33	6	5⅝	7¾	12⅞	12⅞	¼	6⅜	7⅞	9	9	2⅞	34	38		
30	30	29½	40½	39	6	5⅝	7¾	13¼	13¼	¼	6⅜	7⅞	11	11	2⅞	39	44		
36	35¼	34¾	47	45	7½	5¾	9¼	14⅞	15¼	⅝	7¼	7¾	13	13	3¼	48	54		
42	40⅞	40	53	51	7½	5¾	9¼	16	16⅞	⅝	7¼	7¾	15	15	3⅞	54	61		
48	45⅞	45¼	59	57	7½	5¾	9¼	17⅞	17⅞	⅝	7¼	7¾	17	17	4⅞	59	67		

① Use washers with ½" bolts.

□ Shaded sizes are most commonly used and are more readily available.

② Location of head pulley in relation to idler center roll.

35° TROUGHING IMPACT IDLER — EQUAL LENGTH ROLLS

REGREASABLE FACTORY SEALED

B+5302 RG **B+5302 FS**

5-Inch Rubber Rolls

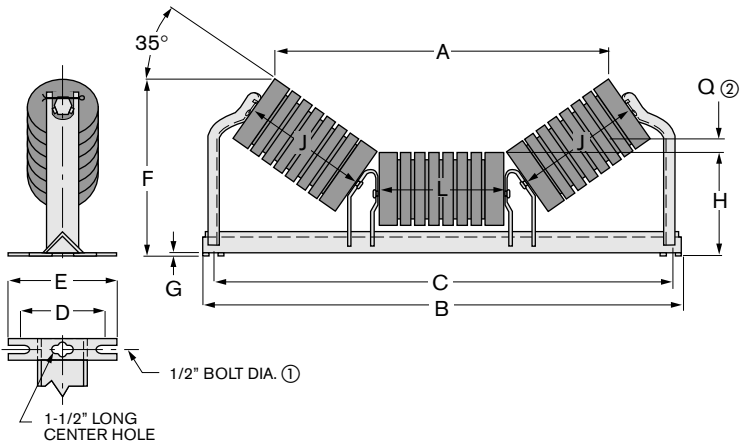

Dimensions in Inches — Average Weight in Pounds

Belt Width	A	B	C	D		E	F	G	H	J	L	Q	Idler Wgt.
				Recom.	Minimum								
18	18⅞	28½	27	6	5⅝	7¾	11⅞	¼	7⅞	7	7	1½	37
20	20⅞	30½	29	6	5⅝	7¾	11⅞	¼	7⅞	7	9	1½	40
24	24⅜	34½	33	6	5⅝	7¾	12⅞	¼	7⅞	9	9	2⅞	45
30	29½	40½	39	6	5⅝	7¾	13¼	¼	7⅞	11	11	2⅞	58
36	34¾	47	45	7½	5¾	9¼	15¼	⅝	7¾	13	13	3¼	66
42	40	53	51	7½	5¾	9¼	16⅞	⅝	7¾	15	15	3⅞	75
48	45¼	59	57	7½	5¾	9¼	17⅞	⅝	7¾	17	17	4⅞	88

① Use washers with ½" bolts.

□ Shaded sizes are most commonly used and are more readily available.

② Location of head pulley in relation to idler center roll.

Note: Dimensions subject to change. Certified drawings are supplied with orders upon request.

REX IDLERS

SERIES B+

35° TROUGHING TRAINING IDLER — EQUAL LENGTH ROLLS

Positive Arm^① Type — Belt Travel One Direction Only

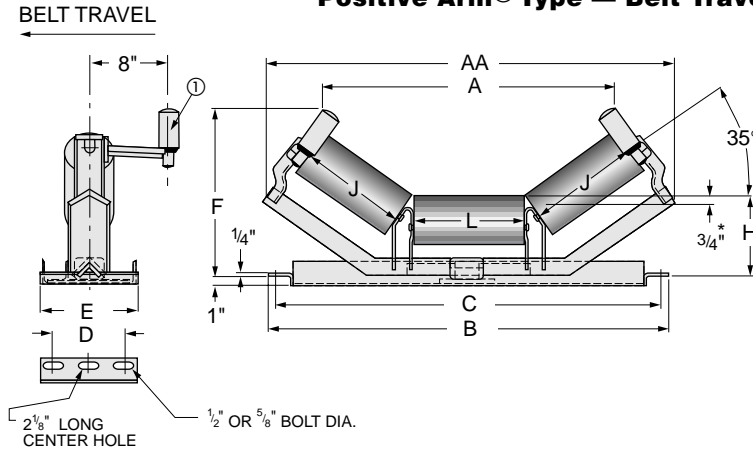

REGREASABLE FACTORY SEALED

B+4312 RG **B+4312 FS**
4-Inch Steel Rolls

B+5312 RG **B+5312 FS**
5-Inch Steel Rolls

Dimensions in Inches — Average Weight in Pounds

Belt Width	A	AA	B	C	D			E	F	H		J	L	Idler Wgt.	
					Recom.	Minimum	Maximum			4" Roll	5" Roll			4" Roll	5" Roll
18	20	30 ¹³ / ₁₆	28 ¹ / ₂	27	7 ¹ / ₂	5 ³ / ₄	8 ⁵ / ₈	10	14 ¹⁵ / ₁₆	7 ⁵ / ₈	8 ¹ / ₈	7	7	78	86
20	22	32 ¹³ / ₁₆	30 ¹ / ₂	29	7 ¹ / ₂	5 ³ / ₄	8 ⁵ / ₈	10	14 ¹⁵ / ₁₆	7 ⁵ / ₈	8 ¹ / ₈	7	9	80	88
24	23 ¹³ / ₁₆	36 ¹ / ₈	34 ¹ / ₂	33	7 ¹ / ₂	5 ³ / ₄	8 ⁵ / ₈	10	17 ¹ / ₈	7 ⁵ / ₈	8 ¹ / ₈	9	9	83	93
30	29 ¹ / ₁₆	41 ³ / ₈	40 ¹ / ₂	39	7 ¹ / ₂	5 ³ / ₄	8 ⁵ / ₈	10	18 ³ / ₁₆	7 ⁵ / ₈	8 ¹ / ₈	11	11	105	115
36	35 ³ / ₄	46 ¹¹ / ₁₆	46 ¹ / ₂	45	7 ¹ / ₂	5 ³ / ₄	8 ⁵ / ₈	10	19 ⁹ / ₁₆	7 ⁵ / ₈	8 ¹ / ₈	13	13	113	124
42	41 ¹ / ₁₆	52 ³ / ₈	52 ¹ / ₂	51	7 ¹ / ₂	5 ³ / ₄	10 ³ / ₄	14 ¹ / ₂	19 ⁹ / ₁₆	8	8 ¹ / ₂	15	15	128	140
48	46 ⁵ / ₁₆	57 ¹¹ / ₁₆	58 ¹ / ₂	57	7 ¹ / ₂	5 ³ / ₄	10 ³ / ₄	14 ¹ / ₂	21 ¹ / ₁₆	8	8 ¹ / ₂	17	17	140	156

★ Approximate distance to the top of the center roll of other idlers.

□ Shaded sizes are most commonly used and are more readily available.

35° TROUGHING TRAINING IDLER — EQUAL LENGTH ROLLS

Actuating Shoe^① Type — Belt Travel Either Direction

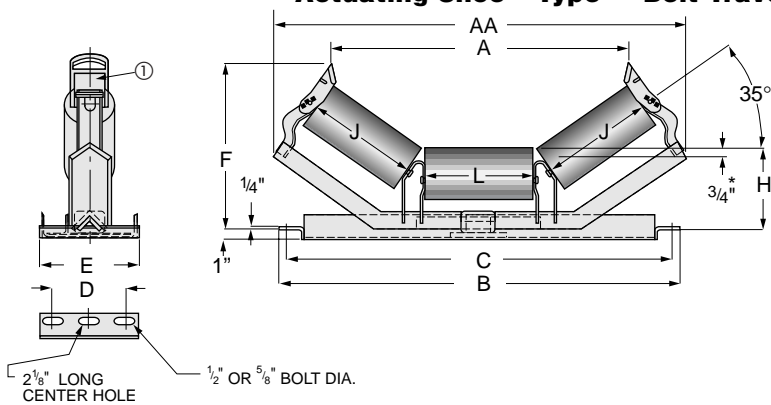

REGREASABLE FACTORY SEALED

B+4310 RG **B+4310 FS**
4-Inch Steel Rolls

B+5310 RG **B+5310 FS**
5-Inch Steel Rolls

Dimensions in Inches — Average Weight in Pounds

Belt Width	A	AA	B	C	D			E	F	H		J	L	Idler Wgt.	
					Recom.	Minimum	Maximum			4" Roll	5" Roll			4" Roll	5" Roll
18	20 ³ / ₈	29 ⁷ / ₁₆	28 ¹ / ₂	27	7 ¹ / ₂	5 ³ / ₄	8 ⁵ / ₈	10	13 ¹⁵ / ₁₆	7 ⁵ / ₈	8 ¹ / ₈	7	7	78	86
20	22 ³ / ₈	31 ⁷ / ₁₆	30 ¹ / ₂	29	7 ¹ / ₂	5 ³ / ₄	8 ⁵ / ₈	10	13 ¹⁵ / ₁₆	7 ⁵ / ₈	8 ¹ / ₈	7	9	80	88
24	25 ³ / ₈	34 ⁷ / ₁₆	34 ¹ / ₂	33	7 ¹ / ₂	5 ³ / ₄	8 ⁵ / ₈	10	15 ¹ / ₈	7 ⁵ / ₈	8 ¹ / ₈	9	9	83	93
30	30 ¹⁵ / ₁₆	40 ¹ / ₁₆	40 ¹ / ₂	39	7 ¹ / ₂	5 ³ / ₄	8 ⁵ / ₈	10	16 ¹ / ₄	7 ⁵ / ₈	8 ¹ / ₈	11	11	105	115
36	36 ³ / ₁₆	45 ⁷ / ₁₆	46 ¹ / ₂	45	7 ¹ / ₂	5 ³ / ₄	8 ⁵ / ₈	10	17 ³ / ₈	7 ⁵ / ₈	8 ¹ / ₈	13	13	113	124
42	41 ¹ / ₂	51 ¹ / ₁₆	52 ¹ / ₂	51	7 ¹ / ₂	5 ³ / ₄	10 ³ / ₄	14 ¹ / ₂	18 ¹⁵ / ₁₆	8	8 ¹ / ₂	15	15	128	140
48	46 ³ / ₄	56 ¹¹ / ₁₆	58 ¹ / ₂	57	7 ¹ / ₂	5 ³ / ₄	10 ³ / ₄	14 ¹ / ₂	20 ¹ / ₁₆	8	8 ¹ / ₂	17	17	140	156

★ Approximate distance to the top of the center roll of other idlers.

□ Shaded sizes are most commonly used and are more readily available.

Note: Dimensions subject to change. Certified drawings are supplied with orders upon request.

REX IDLERS

SERIES B and B+ RETURN IDLER

B+ Rolls can be furnished in polyethylene, ceramic coated or urethane coated.

REGREASABLE FACTORY SEALED

B+4040 RG **B4040 FS**
B+4040 FS

4-Inch Steel Roll

B+5040 RG **B5040 FS**
B+5040 FS

5-Inch Steel Roll

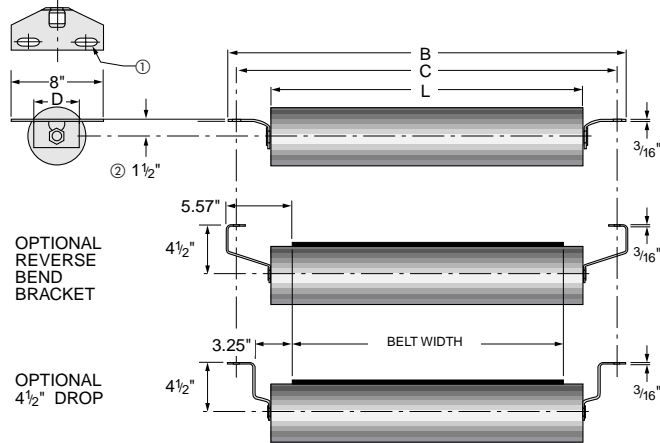

Dimensions in Inches — Average Weight in Pounds

Belt Width	B	C	D			L	Idler Wgt.	
			Recom.	Min.	Max.		4" Roll	5" Roll
18	28½	27	5	3¾	6¼	21	17	20
20	30½	29	5	3¾	6¼	23	18	21
24	34½	33	5	3¾	6¼	27	20	24
30	40½	39	5	3¾	6¼	33	24	29
36	46½	45	5	3¾	6¼	39	29	33
★42	52½	51	5	3¾	6¼	45	33	38
★48	58½	57	5	3¾	6¼	51	39	44

① ½" or ⅝" bolt dia.

② Also available with 11¼" and 16½" drop.

★ These idlers are Series B+.

□ Shaded sizes are most commonly used and are more readily available.

FLAT IDLER

B+ Rolls can be furnished in polyethylene, ceramic coated or urethane coated.

REGREASABLE FACTORY SEALED

B+4020 RG **B4020 FS**
B+4020 FS

4-Inch Steel Roll

B+5020 **B5020 FS**
B+5020 FS

5-Inch Steel Roll

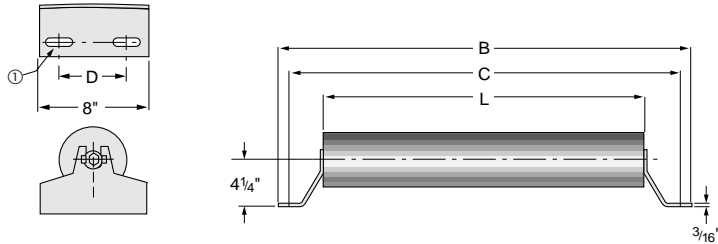

Dimensions in Inches — Average Weight in Pounds

Belt Width	B	C	Recom.		Minimum		Maximum		L	Idler Wgt.	
			D	D ₁	D	D ₁	D	D ₁		4" Roll	5" Roll
18	29	27	5	4	3¾	2¾	6¼	5	21	18	22
20	31	29	5	4	3¾	2¾	6¼	5	23	20	23
24	35	33	5	4	3¾	2¾	6¼	5	27	22	26
30	41	39	5	4	3¾	2¾	6¼	5	33	26	30
36	47	45	5	4	3¾	2¾	6¼	5	39	31	35
★42	53	51	5	4	3¾	2¾	6¼	5	45	35	40
★48	59	57	5	4	3¾	2¾	6¼	5	51	41	46

① ½" or ⅝" bolt.

★ These idlers are Series B+.

□ Shaded sizes are most commonly used and are more readily available.

Note: Dimensions subject to change. Certified drawings are supplied with orders upon request.

REX IDLERS

SERIES B+

RETURN TRAINING IDLER

Positive Arm^① Type — Belt Travel One Direction Only

This trainer can be furnished with a rubber disc, ceramic disc, urethane disc or spiral roll.

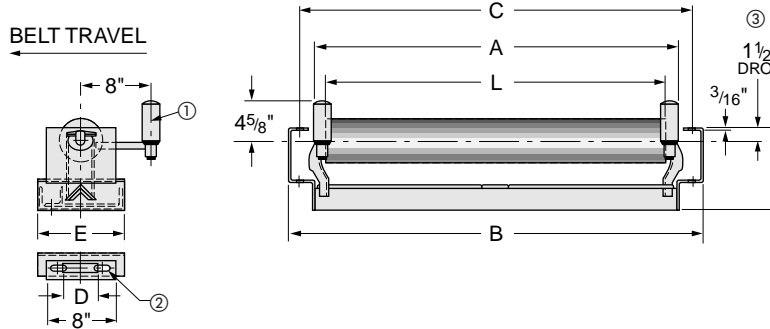

REGREASABLE FACTORY SEALED
B+4052 RG **B+4052 FS**
4-Inch Steel Roll
B+5052 RG **B+5052 FS**
5-Inch Steel Roll

Dimensions in Inches — Average Weight in Pounds

Belt Width	A	B	C	D			E	F	L	Idler Wgt.	
				Recom.	Minimum	Maximum				4" Roll	5" Roll
18	23 ⁵ / ₈	29 ¹ / ₂	27	5	3 ³ / ₄	6 ¹ / ₄	10	9 ¹ / ₂	21	83	90
20	25 ⁵ / ₈	31 ¹ / ₂	29	5	3 ³ / ₄	6 ¹ / ₄	10	9 ¹ / ₂	23	94	102
24	29 ⁵ / ₈	35 ¹ / ₂	33	5	3 ³ / ₄	6 ¹ / ₄	10	9 ¹ / ₂	27	100	110
30	35 ⁵ / ₈	41 ¹ / ₂	39	5	3 ³ / ₄	6 ¹ / ₄	10	9 ¹ / ₂	33	117	126
36	41 ⁵ / ₈	47 ¹ / ₂	45	5	3 ³ / ₄	6 ¹ / ₄	10	9 ¹ / ₂	39	137	148
42	47 ⁵ / ₈	53 ¹ / ₂	51	5	3 ³ / ₄	6 ¹ / ₄	14 ¹ / ₂	10	45	142	157
48	53 ⁵ / ₈	59 ¹ / ₂	57	5	3 ³ / ₄	6 ¹ / ₄	14 ¹ / ₂	10	51	153	167

① Positive Arm.

② 1/2" or 5/8" bolt dia.

③ Also available with 4 1/2" and 11 3/4" drop.

□ Shaded sizes are most commonly used and are more readily available.

RETURN TRAINING IDLER

Actuating Shoe^① Type — Belt Travel Either Direction

This trainer can be furnished with a rubber disc, ceramic disc, urethane disc or spiral roll.

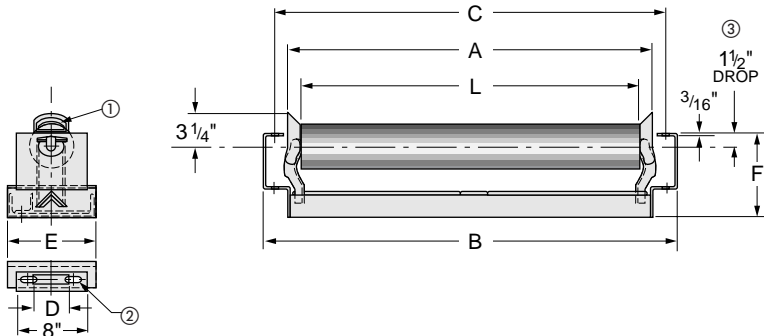

REGREASABLE FACTORY SEALED
B+4051 RG **B+4051 FS**
4-Inch Steel Roll
B+5051 RG **B+5051 FS**
5-Inch Steel Roll

Dimensions in Inches — Average Weight in Pounds

Belt Width	A	B	C	D			E	F	L	Idler Wgt.	
				Recom.	Minimum	Maximum				4" Roll	5" Roll
18	24 ¹ / ₈	29 ¹ / ₂	27	5	3 ³ / ₄	6 ¹ / ₄	10	9 ¹ / ₂	21	81	88
20	26 ¹ / ₈	31 ¹ / ₂	29	5	3 ³ / ₄	6 ¹ / ₄	10	9 ¹ / ₂	23	93	100
24	30 ¹ / ₈	35 ¹ / ₂	33	5	3 ³ / ₄	6 ¹ / ₄	10	9 ¹ / ₂	27	96	112
30	36 ¹ / ₈	41 ¹ / ₂	39	5	3 ³ / ₄	6 ¹ / ₄	10	9 ¹ / ₂	33	115	125
36	42 ¹ / ₈	47 ¹ / ₂	45	5	3 ³ / ₄	6 ¹ / ₄	10	9 ¹ / ₂	39	135	146
42	48 ¹ / ₈	53 ¹ / ₂	51	5	3 ³ / ₄	6 ¹ / ₄	14 ¹ / ₂	10	45	140	152
48	54 ¹ / ₈	59 ¹ / ₂	57	5	3 ³ / ₄	6 ¹ / ₄	14 ¹ / ₂	10	51	151	165

① Actuating Shoe.

② 1/2" or 5/8" bolt dia.

③ Also available with 4 1/2" and 11 3/4" drop.

□ Shaded sizes are most commonly used and are more readily available.

Note: Dimensions subject to change. Certified drawings are supplied with orders upon request.

REX IDLERS

SERIES B+

FLAT TRAINING IDLER

Positive Arm^① Type — Belt Travel One Direction Only

This trainer can be furnished with a rubber disc, ceramic disc, urethane disc or spiral roll.

REGREASABLE FACTORY SEALED
B+4031 RG **B+4031 FS**
4-Inch Steel Roll
B+5031 RG **B+5031 FS**
5-Inch Steel Roll

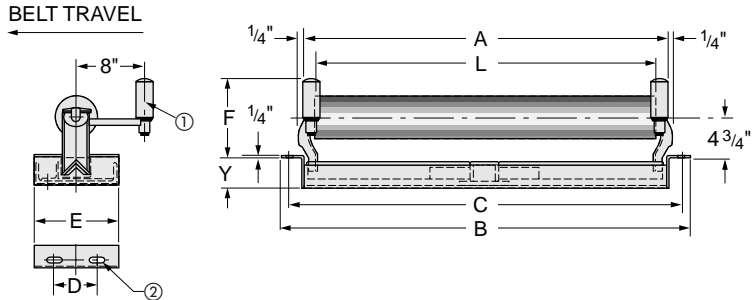

Dimensions in Inches — Average Weight in Pounds

Belt Width	A	B	C	D			E	F	L	Y	Idler Wgt.	
				Recom.	Min.	Max.					4" Roll	5" Roll
18	23 ⁵ / ₈	28 ³ / ₄	27	5	3 ³ / ₄	6 ¹ / ₄	10	9 ³ / ₈	21	3 ¹ / ₈	78	85
20	25 ⁵ / ₈	30 ³ / ₄	29	5	3 ³ / ₄	6 ¹ / ₄	10	9 ³ / ₈	23	3 ¹ / ₈	89	97
24	29 ⁵ / ₈	34 ³ / ₄	33	5	3 ³ / ₄	6 ¹ / ₄	10	9 ³ / ₈	27	3 ¹ / ₈	95	105
30	35 ⁵ / ₈	40 ³ / ₄	39	5	3 ³ / ₄	6 ¹ / ₄	10	9 ³ / ₈	33	3 ¹ / ₈	112	121
36	41 ⁵ / ₈	46 ³ / ₄	45	5	3 ³ / ₄	6 ¹ / ₄	10	9 ³ / ₈	39	3 ³ / ₁₆	132	143
42	47 ⁵ / ₈	52 ³ / ₄	51	5	3 ³ / ₄	6 ¹ / ₄	14 ¹ / ₂	9 ³ / ₈	45	3 ¹ / ₁₆	137	152
48	53 ⁵ / ₈	58 ³ / ₄	57	5	3 ³ / ₄	6 ¹ / ₄	14 ¹ / ₂	9 ³ / ₈	51	3 ¹ / ₁₆	148	162

① For belt travel in both directions replace positive arms with actuating shoes. □ Shaded sizes are most commonly used and are more readily available.
 ② 1/2" or 5/8" bolt dia.

RETURN TRAINING IDLER

Inclined Pivot Type — Belt Travel One Direction Only

This trainer can be furnished with a rubber disc, ceramic disc, urethane disc or spiral roll.

REGREASABLE FACTORY SEALED
B+4050 RG **B+4050 FS**
4-Inch Steel Roll
B+5050 RG **B+5050 FS**
5-Inch Steel Roll

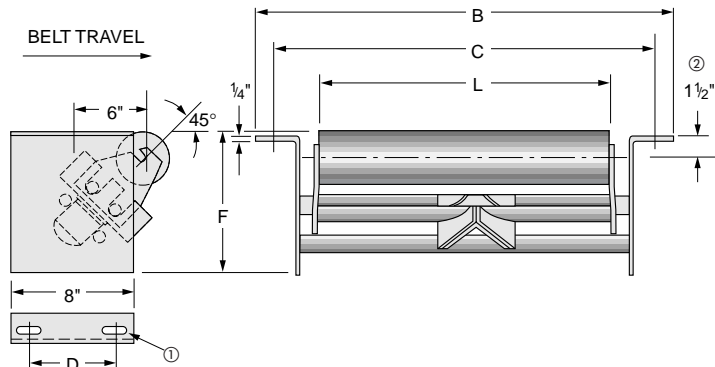

Dimensions in Inches — Average Weight in Pounds

Belt Width	B	C	D			F		L	Idler Wgt.	
			Recom.	Minimum	Maximum	4" Roll	5" Roll		4" Roll	5" Roll
18	29	27	5	3 ³ / ₄	6 ¹ / ₄	11 ¹ / ₁₆	12 ³ / ₁₆	21	74	81
20	31	29	5	3 ³ / ₄	6 ¹ / ₄	11 ¹ / ₁₆	12 ³ / ₁₆	23	77	85
24	35	33	5	3 ³ / ₄	6 ¹ / ₄	11 ¹ / ₁₆	12 ³ / ₁₆	27	85	94
30	41	39	5	3 ³ / ₄	6 ¹ / ₄	11 ¹ / ₁₆	12 ³ / ₁₆	33	98	108
36	47	45	5	3 ³ / ₄	6 ¹ / ₄	11 ¹ / ₁₆	12 ³ / ₁₆	39	108	119
42	53	51	5	3 ³ / ₄	6 ¹ / ₄	11 ¹ / ₁₆	12 ³ / ₁₆	45	120	133
48	59	57	5	3 ³ / ₄	6 ¹ / ₄	11 ¹ / ₁₆	12 ³ / ₁₆	51	132	146

① 1/2" or 5/8" bolt dia. □ Shaded sizes are most commonly used and are more readily available.
 ② Also available with a 4 1/2" or 11 3/4" drop.

Note: Dimensions subject to change. Certified drawings are supplied with orders upon request.

REX IDLERS

SERIES B+

DISC RETURN IDLER

Rex Disc Return Idlers minimize belt misalignment which can cause damage to the belt, resulting from material build-up on the return idler rolls. Available with rubber, ceramic or urethane discs.

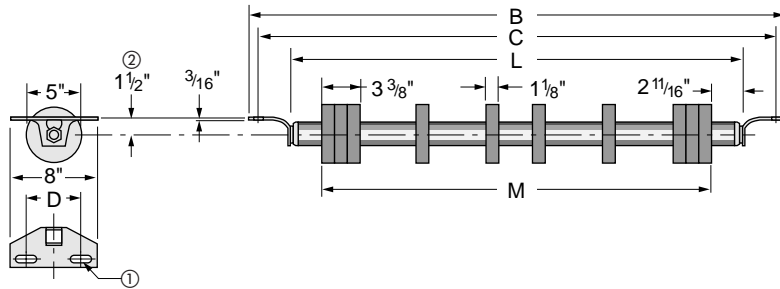

REGREASABLE FACTORY SEALED
B+5043 RG **B+5043 FS**
5-Inch Disc Roll

Dimensions in Inches — Average Weight in Pounds

Belt Width	B	C	D			L	M	No. of Discs	Idler Wgt.
			Recom.	Minimum	Maximum				
18	28½	27	5	¾	6¼	21	15¾	7	17
20	30½	29	5	¾	6¼	23	17¾	7	19
24	34½	33	5	¾	6¼	27	21¾	8	21
30	40½	39	5	¾	6¼	33	27¾	9	24
36	46½	45	5	¾	6¼	39	33¾	10	27
42	52½	51	5	¾	6¼	45	39¾	11	31
48	58½	57	5	¾	6¼	51	45¾	12	36

① ½" or ⅝" bolt dia.

② Also available with a 4½", 11¼", 16½" drop.
 For reverse bend brackets, see page 18.

□ Shaded sizes are most commonly used and are more readily available.

SERIES C SPIRAL RETURN IDLER

Belt Travel One Direction

Rex Spiral Return Idlers minimize belt fleet and damage on the return belt which would otherwise result from material build-up. The correct direction of rotation is important and is clearly marked on each idler. The "V" formed by right-hand and left-hand spirals should point in the direction of rotation.

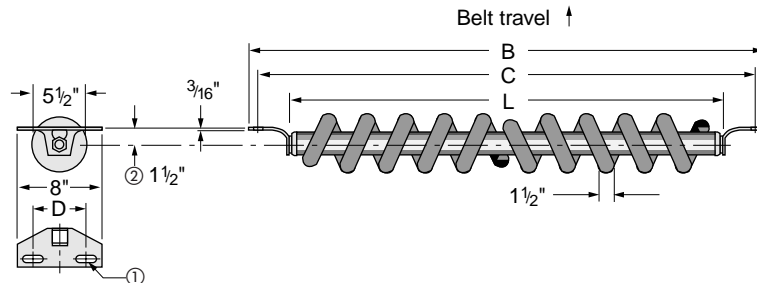

REGREASABLE FACTORY SEALED
C6042 RG **C6042 FS**
5½-Inch Rubber Spiral Roll

Dimensions in Inches — Average Weight in Pounds

Belt Width	B	C	D			L	Idler Wgt.
			Recom.	Minimum	Maximum		
18	28½	27	5	¾	6¼	21	19
20	30½	29	5	¾	6¼	23	22
24	34½	33	5	¾	6¼	27	24
30	40½	39	5	¾	6¼	33	28
36	46½	45	5	¾	6¼	39	33
42	52½	51	5	¾	6¼	45	39
48	58½	57	5	¾	6¼	51	44

① ½" or ⅝" bolt dia.

② Also available with a 4½", 11¼", 16½" drop.
 For reverse bend brackets, see page 18.

□ Shaded sizes are most commonly used and are more readily available.

Note: Dimensions subject to change. Certified drawings are supplied with orders upon request.

REX IDLERS

Series C and D — CEMA C and D 20°, 35° and 45° Trough — 5" and 6" Roll Diameter Regreasable or Factory Sealed Bearings

The complete line of Rex CEMA Series C and D Idlers, with off-the-shelf availability . . .

Reduced Regreasing Time

Easy, convenient, patented one-point greasing — from either side — provides positive through lubrication of all six bearings... saves time, cuts maintenance costs.

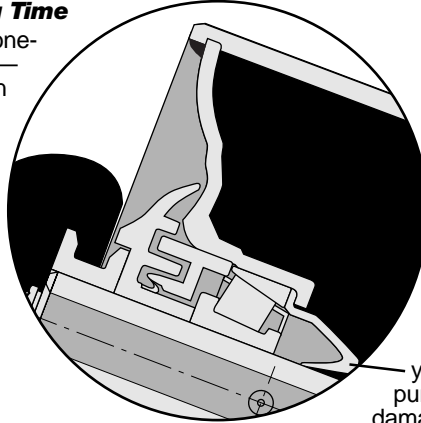

Controlled Greasing Extends Bearing Life

Rear grease seal keeps grease in bearing cavity only, yet allows excess grease to purge, preventing bearing damage through over greasing.

Less Chance of Belt Damage

Rex designed "Mini-Gap" provides smallest possible space between rollers for maximum no-pinch belt protection . . . better belt support and longer belt life.

Simple Belt Training Adjustment

of idlers is made fast and easy using slotted mounting holes. Precision jig welded frame assures positive, accurate alignment.

Grease transfer tubes are totally encapsulated in steel.

Interchangeability

... built to fit existing conveyor frame without cutting or fitting. Conforms to CEMA standards.

Regreasable Idlers

Better Protection Against Abrasives and Moisture

Rex offers a special combination labyrinth with wiping seal and protective outer shield for your operating environment. This seal has *five hard-to-get-through* passages filled with grease to block contaminants from the roller bearings. The outer and inner seals are close tolerance injection molded nonmetallic. The labyrinth/shield seal is particularly excellent for long overland horizontal conveyors, because of its low friction torque or for applications where water is present or when frequent washdowns are required.

REX IDLERS

Series C and D — CEMA C and D 20°, 35° and 45° Trough — 5" and 6" Roll Diameter Regreasable or Factory Sealed

offer low initial and maintenance costs, extra dependability for moderate to heavy duty applications.

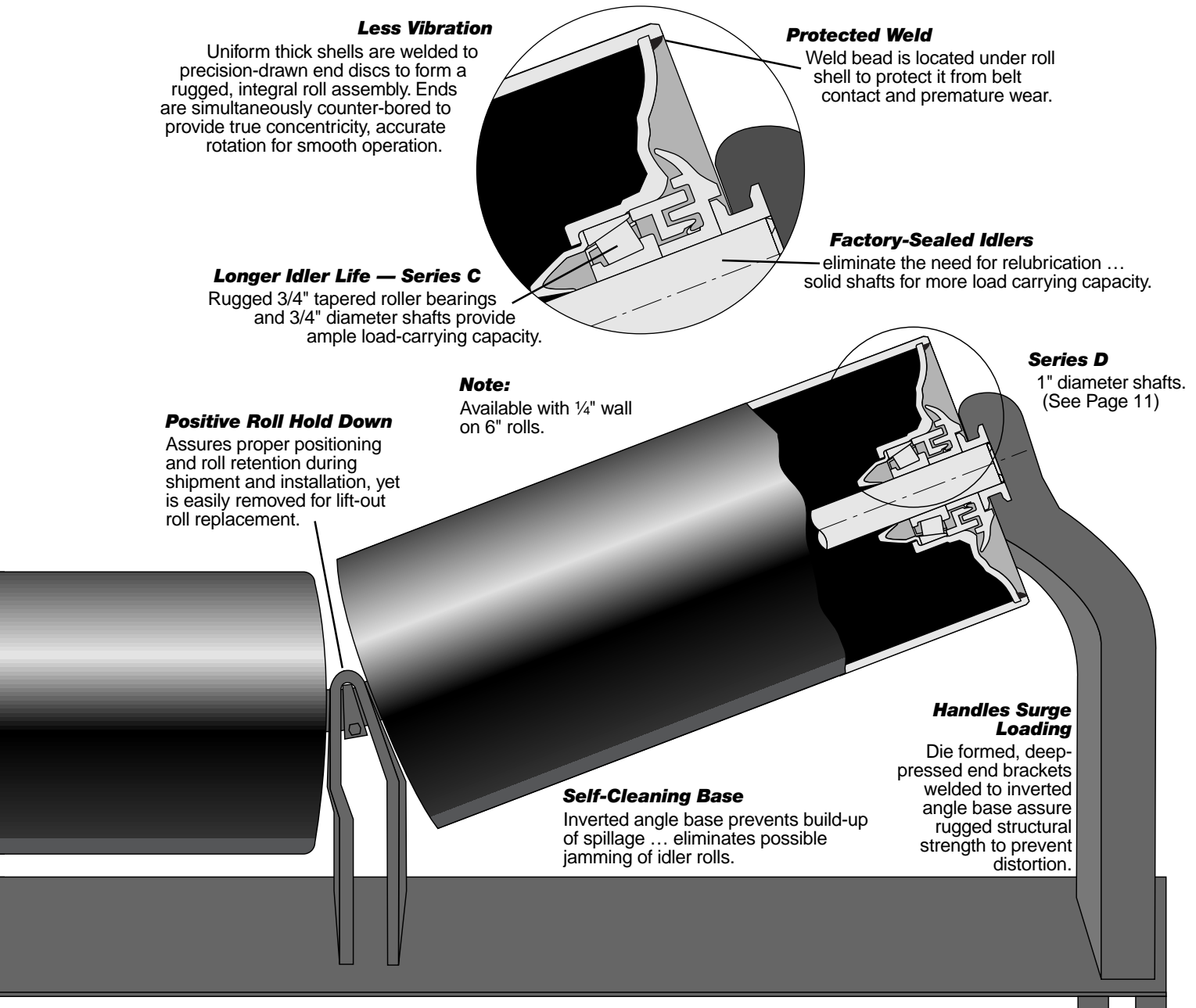

Factory-Sealed Idlers

Better Protection Against Abrasives

Rex offers a special combination labyrinth with wiping seal and protective outer shield for your operating environment. This seal has five hard-to-get-through passages filled with grease to block contaminants from the roller bearings. The outer and inner seals are close tolerance injection molded nonmetallic. This product will provide excellent service in most environments and where minimum maintenance can be provided. Solid shafts are standard.

REX IDLERS

SERIES C and D

20° TROUGHING IDLER — EQUAL LENGTH ROLLS

REGREASABLE FACTORY SEALED

C5200 RG C5200 FS
D5200 RG D5200 FS

5-Inch Steel Rolls

C6200 RG C6200 FS
D6200 RG D6200 FS

6-Inch Steel Rolls ③

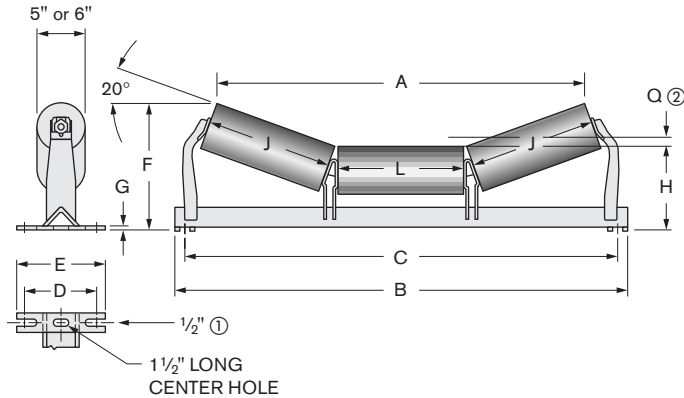

Dimensions in Inches — Average Weight in Pounds

Belt Width	A		B	C	D		E	F		G	H		J	L	Q	Idler Wgt. (Series C)	
	5" Roll	6" Roll			Recom.	Min.		5" Roll	6" Roll		5" Roll	6" Roll				5"	6"
	18	20 ¹³ / ₁₆			20 ¹ / ₂	29		27	7 ¹ / ₂		5 ³ / ₄	9 ¹ / ₄				11	11 ¹ / ₂
20	22 ¹³ / ₁₆	22 ¹ / ₂	31	29	7 ¹ / ₂	5 ³ / ₄	9 ¹ / ₄	11	11 ¹ / ₂	5 ¹ / ₁₆	8 ⁹ / ₁₆	9 ¹ / ₁₆	7	9	1 ⁵ / ₁₆	45	53
24	26 ¹ / ₂	26 ³ / ₁₆	35	33	7 ¹ / ₂	5 ³ / ₄	9 ¹ / ₄	11 ¹¹ / ₁₆	12 ³ / ₁₆	5 ¹ / ₁₆	8 ⁹ / ₁₆	9 ¹ / ₁₆	9	9	1 ¹ / ₄	49	58
30	32 ³ / ₁₆	31 ¹⁵ / ₁₆	41	39	7 ¹ / ₂	5 ³ / ₄	9 ¹ / ₄	12 ³ / ₈	12 ⁷ / ₈	5 ¹ / ₁₆	8 ⁹ / ₁₆	9 ¹ / ₁₆	11	11	1 ⁹ / ₁₆	57	64
36	38 ¹ / ₁₆	37 ¹ / ₁₆	47	45	7 ¹ / ₂	5 ³ / ₄	9 ¹ / ₄	13 ¹ / ₈	13 ³ / ₈	5 ¹ / ₁₆	8 ¹ / ₁₆	9 ³ / ₁₆	13	13	1 ¹⁵ / ₁₆	65	73
42	43 ¹³ / ₁₆	43 ⁷ / ₁₆	53	51	7 ¹ / ₂	5 ³ / ₄	9 ¹ / ₄	14 ¹ / ₈	14 ⁹ / ₁₆	5 ¹ / ₁₆	9	9 ¹ / ₂	15	15	2 ¹ / ₄	72	82
48	49 ⁹ / ₁₆	49 ³ / ₁₆	59	57	7 ¹ / ₂	5 ³ / ₄	9 ¹ / ₄	14 ¹³ / ₁₆	15 ¹ / ₄	5 ¹ / ₁₆	9	9 ¹ / ₂	17	17	2 ³ / ₈	83	92
54	55 ⁵ / ₁₆	55	65 ¹ / ₂	63	9	6 ³ / ₈	11 ¹ / ₂	15 ⁷ / ₈	16 ⁵ / ₈	3 ¹ / ₈	9 ¹ / ₄	9 ³ / ₄	19	19	3	94	105
60	61 ¹ / ₁₆	60 ¹ / ₄	71 ¹ / ₂	69	9	6 ³ / ₈	11 ¹ / ₂	16 ⁹ / ₁₆	17	3 ¹ / ₈	9 ¹ / ₄	9 ³ / ₄	21	21	3 ¹ / ₄	104	116
72	72 ³ / ₈	72 ³ / ₈	83 ¹ / ₂	81	9	7 ³ / ₄	11 ¹ / ₂	18 ⁹ / ₁₆	18 ³ / ₄	3 ¹ / ₈	9 ¹¹ / ₁₆	10 ³ / ₁₆	25	25	3 ³ / ₈	127	141

① Use washers on 1/2-inch bolts.

□ Shaded sizes are most commonly used and are more readily available.

② Location of head pulley in relation to idler center roll.

③ Available in 1/4" roll wall thickness.

20° TROUGHING IMPACT IDLER — EQUAL LENGTH ROLLS

REGREASABLE FACTORY SEALED

C5202 RG C5202 FS
D5202 RG D5202 FS

5-Inch Rolls

C6202 RG C6202 FS
D6202 RG D6202 FS

6-Inch Rolls

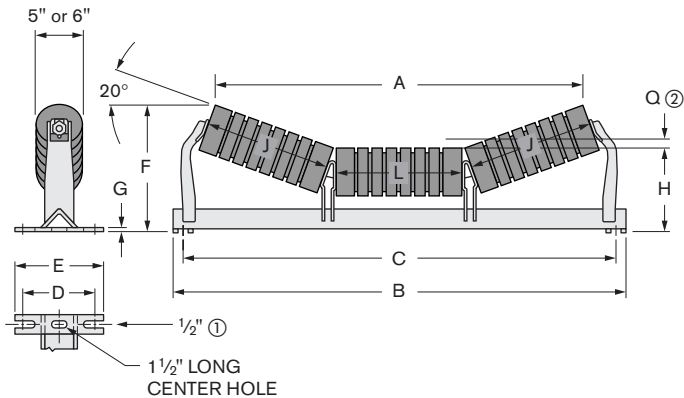

Dimensions in Inches — Average Weight in Pounds

Belt Width	A		B	C	D		E	F		G	H		J	L	Q	Idler Wgt. (Series C)	
	5" Roll	6" Roll			Recom.	Min.		5" Roll	6" Roll		5" Roll	6" Roll				5"	6"
	18	20 ¹³ / ₁₆			20 ¹ / ₂	29		27	7 ¹ / ₂		5 ³ / ₄	9 ¹ / ₄				11	11 ¹ / ₂
20	22 ¹³ / ₁₆	22 ¹ / ₂	31	29	7 ¹ / ₂	5 ³ / ₄	9 ¹ / ₄	11	11 ¹ / ₂	5 ¹ / ₁₆	8 ⁹ / ₁₆	9 ¹ / ₁₆	7	9	1 ⁵ / ₁₆	46	54
24	26 ¹ / ₂	26 ³ / ₁₆	35	33	7 ¹ / ₂	5 ³ / ₄	9 ¹ / ₄	11 ¹¹ / ₁₆	12 ³ / ₁₆	5 ¹ / ₁₆	8 ⁹ / ₁₆	9 ¹ / ₁₆	9	9	1 ¹ / ₄	50	60
30	32 ³ / ₁₆	31 ¹⁵ / ₁₆	41	39	7 ¹ / ₂	5 ³ / ₄	9 ¹ / ₄	12 ³ / ₈	12 ⁷ / ₈	5 ¹ / ₁₆	8 ⁹ / ₁₆	9 ¹ / ₁₆	11	11	1 ⁹ / ₁₆	60	68
36	38 ¹ / ₁₆	37 ¹ / ₁₆	47	45	7 ¹ / ₂	5 ³ / ₄	9 ¹ / ₄	13 ¹ / ₈	13 ³ / ₈	5 ¹ / ₁₆	8 ¹ / ₁₆	9 ³ / ₁₆	13	13	1 ¹⁵ / ₁₆	69	76
42	43 ¹³ / ₁₆	43 ⁷ / ₁₆	53	51	7 ¹ / ₂	5 ³ / ₄	9 ¹ / ₄	14 ¹ / ₈	14 ⁹ / ₁₆	5 ¹ / ₁₆	9	9 ¹ / ₂	15	15	2 ¹ / ₄	76	85
48	49 ⁹ / ₁₆	49 ³ / ₁₆	59	57	7 ¹ / ₂	5 ³ / ₄	9 ¹ / ₄	14 ¹³ / ₁₆	15 ¹ / ₄	5 ¹ / ₁₆	9	9 ¹ / ₂	17	17	2 ³ / ₈	86	97
54	55 ⁵ / ₁₆	55	65 ¹ / ₂	63	9	6 ³ / ₈	11 ¹ / ₂	15 ⁷ / ₈	16 ⁵ / ₈	3 ¹ / ₈	9 ¹ / ₄	9 ³ / ₄	19	19	3	98	109
60	61 ¹ / ₁₆	60 ¹ / ₄	71 ¹ / ₂	69	9	6 ³ / ₈	11 ¹ / ₂	16 ⁹ / ₁₆	17	3 ¹ / ₈	9 ¹ / ₄	9 ³ / ₄	21	21	3 ¹ / ₄	109	121
72	72 ³ / ₈	72 ³ / ₈	83 ¹ / ₂	81	9	7 ³ / ₄	11 ¹ / ₂	18 ⁹ / ₁₆	18 ³ / ₄	3 ¹ / ₈	9 ¹¹ / ₁₆	10 ³ / ₁₆	25	25	3 ³ / ₈	133	145

① Use washers on 1/2-inch bolts.

□ Shaded sizes are most commonly used and are more readily available.

② Location of head pulley in relation to idler center roll.

Note: Dimensions subject to change. Certified dimensions of ordered material furnished on request.

REX IDLERS

SERIES C and D

20° TROUGHING IDLER — EQUAL LENGTH ROLLS

Positive Arm Type — Belt Travel One Direction Only

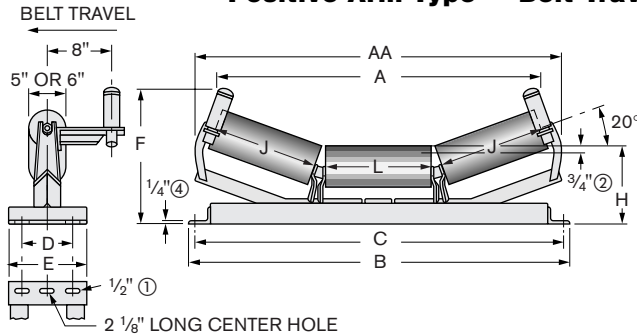

REGREASABLE FACTORY SEALED

C5212 RG C5212 FS
D5212 RG D5212 FS

5-Inch Steel Rolls

C6212 RG C6212 FS
D6212 RG D6212 FS

6-Inch Steel Rolls ③

Dimensions in Inches — Average Weight in Pounds

Belt Width	A	AA	B	C	D			E	F	H		J	L	Idler Wgt. (Series C)	
					Recom.	Min.	Max.			5" Roll	6" Roll			5"	6"
18	23 ³ / ₁₆	28 ⁹ / ₁₆	29	27	7 ¹ / ₂	5 ³ / ₄	8 ⁸ / ₁₆	10	14 ³ / ₁₆	9 ¹ / ₄	9 ³ / ₄	7	7	102	114
20	25 ³ / ₁₆	30 ⁹ / ₁₆	31	29	7 ¹ / ₂	5 ³ / ₄	8 ⁸ / ₁₆	10	14 ³ / ₁₆	9 ¹ / ₄	9 ³ / ₄	7	9	107	119
24	28 ¹⁵ / ₁₆	34 ⁹ / ₁₆	35	33	7 ¹ / ₂	5 ³ / ₄	8 ⁸ / ₁₆	10	14 ⁷ / ₁₆	9 ¹ / ₄	9 ³ / ₄	9	9	118	130
30	34 ¹ / ₁₆	40 ¹ / ₁₆	41	39	7 ¹ / ₂	5 ³ / ₄	8 ⁸ / ₁₆	10	15 ⁹ / ₁₆	9 ¹ / ₄	9 ³ / ₄	11	11	132	145
36	40 ¹ / ₂	45 ⁷ / ₁₆	47	45	7 ¹ / ₂	5 ³ / ₄	8 ⁸ / ₁₆	10	16 ³ / ₁₆	9 ⁹ / ₁₆	9 ¹³ / ₁₆	13	13	146	159
42	46 ¹ / ₁₆	51 ¹³ / ₁₆	53	51	7 ¹ / ₂	5 ³ / ₄	10 ³ / ₄	14 ¹ / ₂	17 ¹ / ₂	9 ¹³ / ₁₆	10 ⁵ / ₁₆	15	15	163	175
48	52	57 ⁹ / ₁₆	59	57	7 ¹ / ₂	5 ³ / ₄	10 ³ / ₄	14 ¹ / ₂	18 ³ / ₁₆	9 ¹³ / ₁₆	10 ⁹ / ₁₆	17	17	178	191
54	57 ¹ / ₄	63 ⁹ / ₁₆	65	63	9	5 ³ / ₄	10 ³ / ₄	14 ¹ / ₂	19 ¹ / ₄	10 ⁹ / ₁₆	10 ¹¹ / ₁₆	19	19	192	206
60	63 ¹ / ₂	69 ⁹ / ₁₆	71	69	9	5 ³ / ₄	10 ³ / ₄	14 ¹ / ₂	19 ¹⁵ / ₁₆	10 ⁹ / ₁₆	10 ¹¹ / ₁₆	21	21	208	221
72	75	80 ¹ / ₄	83	81	9	5 ³ / ₄	10 ³ / ₄	16 ¹ / ₂	21 ⁵ / ₁₆	10 ³ / ₁₆	10 ¹¹ / ₁₆	25	25	236	253

① Use washers on 1/2-inch bolts.

② Approximate distance to the top of the center roll of other idlers.

③ Available in 1/4" roll wall thickness.

④ .31"-.72" belt width

□ Shaded sizes are most commonly used and are more readily available.

20° TROUGHING IMPACT IDLER — EQUAL LENGTH ROLLS

Actuating Shoe Type — Belt Travel Either Direction

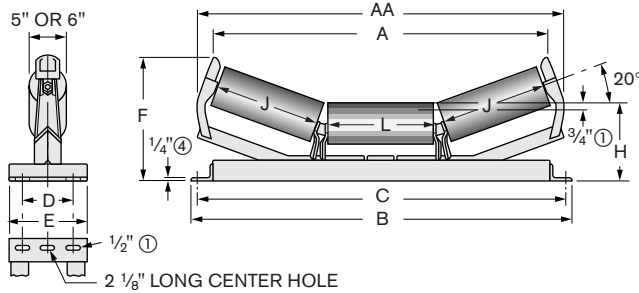

REGREASABLE FACTORY SEALED

C5210 RG C5210 FS
D5210 RG D5210 FS

5-Inch Steel Rolls

C6210 RG C6210 FS
D6210 RG D6210 FS

6-Inch Steel Rolls ③

Dimensions in Inches — Average Weight in Pounds

Belt Width	A		AA	B	C	D			E	F		H		J	L	Idler Wgt. (Series C)	
	5" Dia.	6" Dia.				Recom.	Min.	Max.		5" Dia.	6" Dia.	5" Dia.	6" Dia.			5"	6"
18	23 ³ / ₄	23 ³ / ₈	28 ⁹ / ₁₆	29	27	7 ¹ / ₂	5 ³ / ₄	8 ⁸ / ₁₆	10	13 ³ / ₁₆	14 ¹ / ₄	9 ¹ / ₄	9 ³ / ₄	7	7	100	112
20	25 ³ / ₄	25 ¹ / ₂	30 ⁹ / ₁₆	31	29	7 ¹ / ₂	5 ³ / ₄	8 ⁸ / ₁₆	10	13 ³ / ₁₆	14 ¹ / ₄	9 ¹ / ₄	9 ³ / ₄	7	9	105	117
24	29 ¹ / ₂	28 ⁷ / ₈	34 ⁹ / ₁₆	35	33	7 ¹ / ₂	5 ³ / ₄	8 ⁸ / ₁₆	10	13 ⁷ / ₈	14 ¹⁵ / ₁₆	9 ¹ / ₄	9 ³ / ₄	9	9	116	128
30	35 ¹ / ₄	34 ¹ / ₁₆	40 ¹ / ₁₆	41	39	7 ¹ / ₂	5 ³ / ₄	8 ⁸ / ₁₆	10	14 ⁹ / ₁₆	15 ¹ / ₈	9 ¹ / ₄	9 ³ / ₄	11	11	130	143
36	41	41 ⁷ / ₁₆	45 ⁷ / ₁₆	47	45	7 ¹ / ₂	5 ³ / ₄	8 ⁸ / ₁₆	10	15 ¹ / ₄	16 ³ / ₈	9 ⁹ / ₁₆	9 ¹³ / ₁₆	13	13	144	156
42	46 ³ / ₄	46 ³ / ₁₆	51 ¹³ / ₁₆	53	51	7 ¹ / ₂	5 ³ / ₄	10 ³ / ₄	14 ¹ / ₂	16 ¹ / ₂	17 ⁹ / ₁₆	9 ¹³ / ₁₆	10 ⁵ / ₁₆	15	15	160	172
48	52 ¹ / ₄	51 ¹³ / ₁₆	57 ⁹ / ₁₆	59	57	7 ¹ / ₂	5 ³ / ₄	10 ³ / ₄	14 ¹ / ₂	17 ⁹ / ₁₆	17 ⁹ / ₁₆	9 ¹³ / ₁₆	10 ⁹ / ₁₆	17	17	175	188
54	58 ¹ / ₄	57 ¹ / ₁₆	63 ⁹ / ₁₆	65	63	9	5 ³ / ₄	10 ³ / ₄	14 ¹ / ₂	18 ³ / ₁₆	19 ⁹ / ₁₆	10 ⁹ / ₁₆	10 ¹¹ / ₁₆	19	19	190	203
60	64	63 ⁷ / ₁₆	69 ⁹ / ₁₆	71	69	9	5 ³ / ₄	10 ³ / ₄	14 ¹ / ₂	18 ⁷ / ₁₆	20	10 ³ / ₁₆	10 ¹¹ / ₁₆	21	21	206	218
72	75 ⁵ / ₁₆	75	80 ¹ / ₄	83	81	9	5 ³ / ₄	10 ³ / ₄	16 ¹ / ₂	20 ¹ / ₄	21 ⁵ / ₁₆	10 ³ / ₁₆	10 ¹¹ / ₁₆	25	25	234	250

① Use washers on 1/2-inch bolts.

② Approximate distance to the top of the center roll of other idlers.

③ Available in 1/4" roll wall thickness.

④ .31"-.72" belt width

□ Shaded sizes are most commonly used and are more readily available.

Note: Dimensions subject to change. Certified dimensions of ordered material furnished on request.

REX IDLERS

SERIES C and D

20° TROUGHING IDLER — UNEQUAL LENGTH ROLLS

REGREASABLE FACTORY SEALED

C5201 RG C5201 FS
D5201 RG D5201 FS

5-Inch Steel Rolls

C6201 RG C6201 FS
D6201 RG D6201 FS

6-Inch Steel Rolls ③

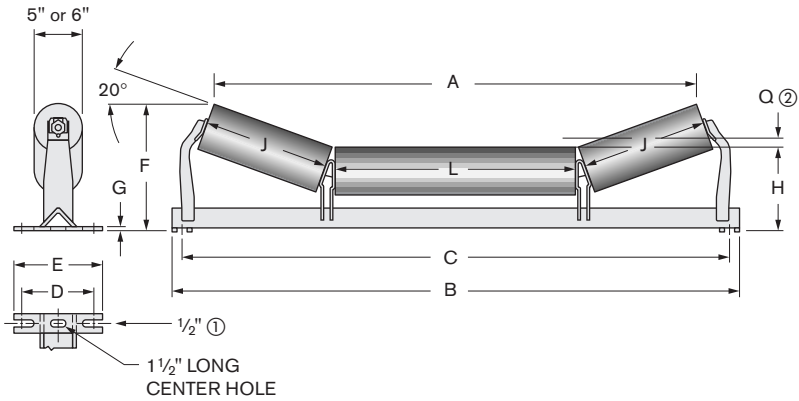

Dimensions in Inches — Average Weight in Pounds

Belt Width	A		B	C	D		E	F		G	H		J	L	Q	Idler Wgt. (Series C)	
	6" Roll	6" Roll			Recom.	Min.		5" Roll	6" Roll		5" Roll	6" Roll				5"	6"
	24	28 ¹⁵ / ₁₆			28½	35½		33	7½		5¾	9¼				11	11½
30	34 ¹⁵ / ₁₆	34½	41½	39	7½	5¾	9¼	11	11½	5/16	8 ⁹ / ₁₆	9 ¹ / ₁₆	7	21	1 ³ / ₁₆	57	64
36	40 ¹⁵ / ₁₆	40½	47½	45	7½	5¾	9¼	11 ¹ / ₁₆	11 ⁹ / ₁₆	5/16	8 ¹¹ / ₁₆	9 ³ / ₁₆	7	27	1 ³ / ₁₆	65	73
42	46 ¹⁵ / ₁₆	46½	53½	51	7½	5¾	9¼	11 ³ / ₁₆	11 ⁷ / ₁₆	5/16	9	9½	7	33	1 ³ / ₁₆	72	82
48	52 ¹⁵ / ₁₆	52½	59½	57	7½	5¾	9¼	11 ³ / ₁₆	11 ⁷ / ₁₆	5/16	9	9½	7	39	1 ³ / ₁₆	83	92
54	58 ¹⁵ / ₁₆	58½	65½	63	9	6¾	11½	11¾	12½	3/8	9¼	9¾	7	45	1 ³ / ₁₆	94	105
60	64 ¹⁵ / ₁₆	64½	71½	69	9	6¾	11½	11¾	12½	3/8	9¼	9¾	7	51	1 ³ / ₁₆	104	116
72	76 ¹⁵ / ₁₆	76½	83½	81	9	7¾	11½	11¾	12½	3/8	9¼	9¾	9	57	1 ³ / ₁₆	123	138

① Use washers on 1/2-inch bolts.

② Location of head pulley in relation to idler center roll.

③ Available in 1/4" roll wall thickness.

Contact Rexnord for load rating.

20° TROUGHING IMPACT IDLER — UNEQUAL LENGTH ROLLS

REGREASABLE FACTORY SEALED

C5203 RG C5203 FS
D5203 RG D5203 FS

5-Inch Rubber Rolls

C6203 RG C6203 FS
D6203 RG D6203 FS

6-Inch Rubber Rolls

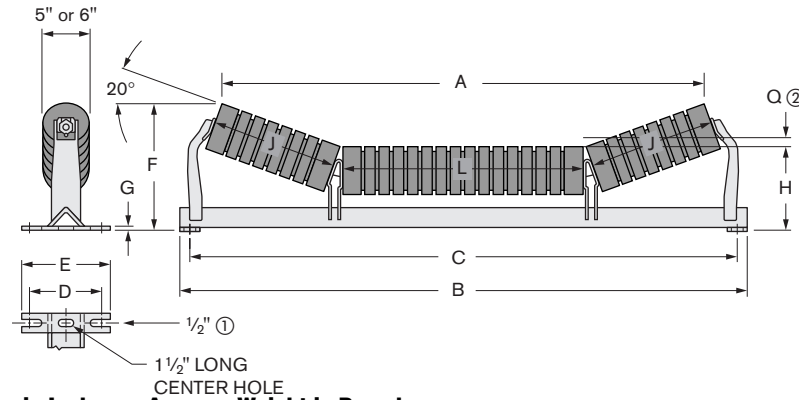

Dimensions in Inches — Average Weight in Pounds

Belt Width	A		B	C	D		E	F		G	H		J	L	Q	Idler Wgt. (Series C)	
	5" Roll	6" Roll			Recom.	Min.		5" Roll	6" Roll		5" Roll	6" Roll				5"	6"
	24	28 ¹⁵ / ₁₆			28½	35½		33	7½		5¾	9¼				11	11½
30	34 ¹⁵ / ₁₆	34½	41½	39	7½	5¾	9¼	11	11½	5/16	8 ⁹ / ₁₆	9 ¹ / ₁₆	7	21	1 ³ / ₁₆	60	68
36	40 ¹⁵ / ₁₆	40½	47½	45	7½	5¾	9¼	11 ¹ / ₁₆	11 ⁹ / ₁₆	5/16	8 ¹¹ / ₁₆	9 ³ / ₁₆	7	27	1 ³ / ₁₆	69	76
42	46 ¹⁵ / ₁₆	46½	53½	51	7½	5¾	9¼	11 ³ / ₁₆	11 ⁷ / ₁₆	5/16	9	9½	7	33	1 ³ / ₁₆	76	85
48	52 ¹⁵ / ₁₆	52½	59½	57	7½	5¾	9¼	11 ³ / ₁₆	11 ⁷ / ₁₆	5/16	9	9½	7	39	1 ³ / ₁₆	86	97
54	58 ¹⁵ / ₁₆	58½	65½	63	9	6¾	11½	11¾	12½	3/8	9¼	9¾	7	45	1 ³ / ₁₆	98	109
60	64 ¹⁵ / ₁₆	64½	71½	69	9	6¾	11½	11¾	12½	3/8	9¼	9¾	7	51	1 ³ / ₁₆	109	121
72	76 ¹⁵ / ₁₆	76½	83½	81	9	7¾	11½	11¾	12½	3/8	9¼	9¾	9	57	1 ³ / ₁₆	130	142

① Use washers on 1/2-inch bolts.

② Location of head pulley in relation to idler center roll.

Contact Rexnord for load rating.

Note: Dimensions subject to change. Certified dimensions of ordered material furnished on request.

REX IDLERS

SERIES C and D

20° TROUGHING IDLER — UNEQUAL LENGTH ROLLS

Positive Arm Type — Belt Travel One Direction Only

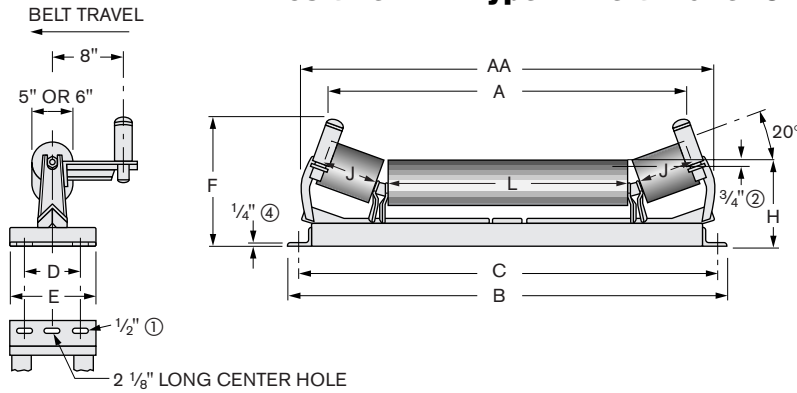

REGREASABLE FACTORY SEALED

C5213 RG C5213 FS
D5213 RG D5213 FS

5-Inch Steel Rolls

C6213 RG C6213 FS
D6213 RG D6213 FS

6-Inch Steel Rolls (3)

Dimensions in Inches — Average Weight in Pounds

Belt Width	A	AA	B	C	D			E	F	H		J	L	Idler Wgt. (Series C)	
					Recom.	Min.	Max.			5" Dia.	6" Dia.			5"	6"
24	29 ³ / ₁₆	34 ¹ / ₁₆	35	33	7 ¹ / ₂	5 ³ / ₄	8 ⁵ / ₁₆	10	14 ³ / ₁₆	9 ¹ / ₄	9 ³ / ₄	7	15	118	132
30	35 ³ / ₁₆	40 ¹ / ₁₆	41	39	7 ¹ / ₂	5 ³ / ₄	8 ⁵ / ₁₆	10	14 ³ / ₁₆	9 ¹ / ₄	9 ³ / ₄	7	21	132	145
36	41 ¹ / ₁₆	46 ¹ / ₁₆	47	45	7 ¹ / ₂	5 ³ / ₄	8 ⁵ / ₁₆	10	14 ¹ / ₄	9 ⁵ / ₁₆	9 ¹³ / ₁₆	7	27	146	159
42	47 ³ / ₁₆	52 ¹ / ₁₆	53	51	7 ¹ / ₂	5 ³ / ₄	10 ¹ / ₄	14 ¹ / ₂	14 ³ / ₄	9 ¹³ / ₁₆	10 ⁵ / ₁₆	7	33	163	175
48	53 ³ / ₁₆	58 ¹ / ₁₆	59	57	7 ¹ / ₂	5 ³ / ₄	10 ¹ / ₄	14 ¹ / ₂	14 ³ / ₄	9 ¹³ / ₁₆	10 ⁵ / ₁₆	7	39	178	192
54	59 ³ / ₁₆	64 ¹ / ₁₆	65	63	9	5 ³ / ₄	10 ¹ / ₄	14 ¹ / ₂	15 ¹ / ₈	10 ³ / ₁₆	10 ¹¹ / ₁₆	7	45	192	206
60	65 ³ / ₁₆	70 ¹ / ₁₆	71	69	9	5 ³ / ₄	10 ¹ / ₄	14 ¹ / ₂	15 ¹ / ₈	10 ³ / ₁₆	10 ¹¹ / ₁₆	7	51	208	221
72	76 ¹³ / ₁₆	82 ³ / ₈	84	81	9 ¹ / ₂	5 ³ / ₄	10 ¹ / ₄	16 ¹ / ₂	16 ³ / ₈	10 ⁹ / ₁₆	11 ¹ / ₁₆	9	57	227	239

① Use washers on 1/2-inch bolts.

② Approximate distance to the top of the center roll of other idlers.

③ Available in 1/4" roll wall thickness.

④ .31"-72" belt width

Contact Rexnord for load rating.

20° TROUGHING TRAINING IDLER — UNEQUAL LENGTH ROLLS

Actuating Shoe Type — Belt Travel Either Direction

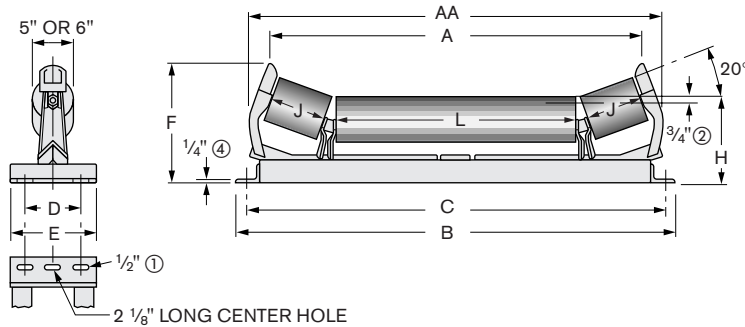

REGREASABLE FACTORY SEALED

C5211 RG C5211 FS
D5211 RG D5211 FS

5-Inch Steel Rolls

C6211 RG C6211 FS
D6211 RG D6211 FS

6-Inch Steel Rolls (3)

Dimensions in Inches — Average Weight in Pounds

Belt Width	A		AA	B	C	D			E	F		H		J	L	Idler Wgt. (Series C)	
	5" Dia.	6" Dia.				Recom.	Min.	Max.		5" Dia.	6" Dia.	5" Dia.	6" Dia.			5"	6"
24	29 ³ / ₁₆	29 ¹ / ₈	34 ¹ / ₁₆	35	33	7 ¹ / ₂	5 ³ / ₄	8 ⁵ / ₁₆	10	13 ³ / ₁₆	14 ¹ / ₄	9 ¹ / ₄	9 ³ / ₄	7	15	116	128
30	35 ³ / ₁₆	35 ¹ / ₈	40 ¹ / ₁₆	41	39	7 ¹ / ₂	5 ³ / ₄	8 ⁵ / ₁₆	10	13 ³ / ₁₆	14 ¹ / ₄	9 ¹ / ₄	9 ³ / ₄	7	21	130	143
36	41 ¹ / ₁₆	41 ¹ / ₈	46 ¹ / ₁₆	47	45	7 ¹ / ₂	5 ³ / ₄	8 ⁵ / ₁₆	10	13 ¹ / ₄	14 ⁵ / ₁₆	9 ⁵ / ₁₆	9 ¹³ / ₁₆	7	27	144	156
42	47 ³ / ₁₆	47 ¹ / ₈	52 ¹ / ₁₆	53	51	7 ¹ / ₂	5 ³ / ₄	10 ¹ / ₄	14 ¹ / ₂	13 ³ / ₄	14 ¹³ / ₁₆	9 ¹³ / ₁₆	10 ⁵ / ₁₆	7	33	160	172
48	53 ³ / ₁₆	53 ¹ / ₈	58 ¹ / ₁₆	59	57	7 ¹ / ₂	5 ³ / ₄	10 ¹ / ₄	14 ¹ / ₂	13 ³ / ₄	14 ¹³ / ₁₆	9 ¹³ / ₁₆	10 ⁵ / ₁₆	7	39	175	190
54	59 ³ / ₁₆	59 ¹ / ₈	64 ¹ / ₁₆	65	63	9	5 ³ / ₄	10 ¹ / ₄	14 ¹ / ₂	14 ¹ / ₈	15 ³ / ₁₆	10 ³ / ₁₆	10 ¹¹ / ₁₆	7	45	190	203
60	65 ³ / ₁₆	65 ¹ / ₈	70 ¹ / ₁₆	71	69	9	5 ³ / ₄	10 ¹ / ₄	14 ¹ / ₂	14 ¹ / ₈	15 ³ / ₁₆	10 ³ / ₁₆	10 ¹¹ / ₁₆	7	51	206	218
72	78 ³ / ₁₆	78 ¹ / ₈	81 ¹ / ₁₆	84	81	9 ¹ / ₂	5 ³ / ₄	10 ¹ / ₄	16 ¹ / ₂	14 ¹ / ₈	15 ³ / ₁₆	10 ⁹ / ₁₆	11 ¹ / ₁₆	9	57	225	237

① Use washers on 1/2-inch bolts.

② Approximate distance to the top of the center roll of other idlers.

③ Available in 1/4" roll wall thickness.

④ .31"-72" belt width

Contact Rexnord for load rating.

Note: Dimensions subject to change. Certified dimensions of ordered material furnished on request.

REX IDLERS

SERIES C and D

35° TROUGHING IDLER — EQUAL LENGTH ROLLS

REGREASABLE FACTORY SEALED

C5300 RG C5300 FS
D5300 RG D5300 FS

5-Inch Steel Rolls

C6300 RG C6300 FS
D6300 RG D6300 FS

6-Inch Steel Rolls ③

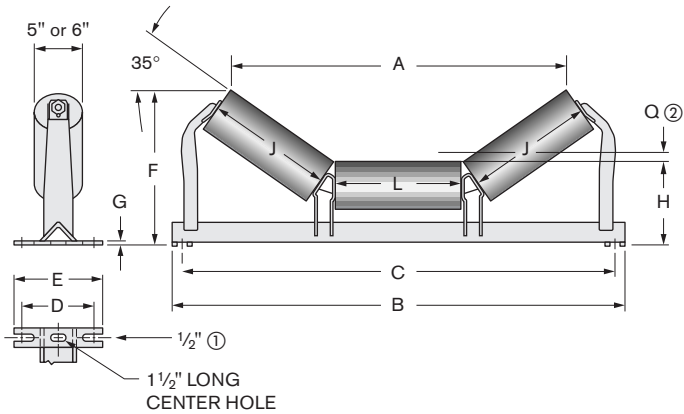

Dimensions in Inches — Average Weight in Pounds

Belt Width	A		B	C	D		E	F		G	H		J	L	Q	Idler Wgt. (Series C)	
	6\"	6\"			Recom.	Min.		5\"	6\"		5\"	6\"				5\"	6\"
	Roll	Roll						Roll	Roll		Roll	Roll					
18	18 ¹⁵ / ₁₆	18 ³ / ₈	29	27	7 ¹ / ₂	5 ³ / ₄	9 ¹ / ₄	12 ¹ / ₁₆	13 ¹ / ₁₆	5 ¹ / ₁₆	8 ⁹ / ₁₆	9 ¹ / ₁₆	7	7	1 ¹ / ₂	42	49
20	20 ¹⁵ / ₁₆	20 ³ / ₈	31	29	7 ¹ / ₂	5 ³ / ₄	9 ¹ / ₄	12 ¹ / ₁₆	13 ¹ / ₁₆	5 ¹ / ₁₆	8 ⁹ / ₁₆	9 ¹ / ₁₆	7	9	1 ¹ / ₂	46	54
24	24 ³ / ₁₆	23 ³ / ₈	35	33	7 ¹ / ₂	5 ³ / ₄	9 ¹ / ₄	13 ¹³ / ₁₆	14 ³ / ₈	5 ¹ / ₁₆	8 ⁹ / ₁₆	9 ¹ / ₁₆	9	9	2 ¹ / ₈	50	59
30	29 ⁷ / ₁₆	28 ⁷ / ₈	41	39	7 ¹ / ₂	5 ³ / ₄	9 ¹ / ₄	14 ¹³ / ₁₆	15 ⁵ / ₈	5 ¹ / ₁₆	8 ⁹ / ₁₆	9 ¹ / ₁₆	11	11	2 ¹¹ / ₁₆	58	69
36	34 ³ / ₄	34 ³ / ₁₆	47	45	7 ¹ / ₂	5 ³ / ₄	9 ¹ / ₄	16 ¹ / ₈	16 ⁹ / ₁₆	5 ¹ / ₁₆	8 ¹¹ / ₁₆	9 ⁹ / ₁₆	13	13	3 ¹ / ₄	69	78
42	40	39 ⁷ / ₁₆	53	51	7 ¹ / ₂	5 ³ / ₄	9 ¹ / ₄	17 ⁷ / ₈	18	5 ¹ / ₁₆	9	9 ¹ / ₂	15	15	3 ³ / ₁₆	77	88
48	45 ⁵ / ₁₆	44 ³ / ₄	59	57	7 ¹ / ₂	5 ³ / ₄	9 ¹ / ₄	18 ³ / ₄	19 ⁹ / ₁₆	5 ¹ / ₁₆	9	9 ¹ / ₂	17	17	4 ⁷ / ₁₆	90	101
54	50 ⁹ / ₁₆	50	65 ¹ / ₂	63	9	6 ³ / ₈	11 ¹ / ₂	20 ¹ / ₄	20 ¹¹ / ₁₆	3 ⁵ / ₈	9 ¹ / ₄	9 ³ / ₄	19	19	5	102	115
60	55 ⁷ / ₈	55 ¹ / ₄	71 ¹ / ₂	69	9	6 ³ / ₈	11 ¹ / ₂	21 ⁷ / ₁₆	21 ¹³ / ₁₆	3 ⁵ / ₈	9 ¹ / ₄	9 ³ / ₄	21	21	5 ⁹ / ₁₆	114	130
72	66 ¹ / ₄	65 ⁷ / ₈	83 ¹ / ₂	81	9	6 ¹ / ₄	11 ¹ / ₂	24	24 ¹ / ₂	3 ⁵ / ₈	9 ¹¹ / ₁₆	10 ³ / ₁₆	25	25	6 ¹ / ₁₆	148	157

① Use washers on 1/2-inch bolts.

□ Shaded sizes are most commonly used and are more readily available.

② Location of head pulley in relation to idler center roll.

③ Available in 1/4\" roll wall thickness.

35° TROUGHING IMPACT IDLER — EQUAL LENGTH ROLLS

REGREASABLE FACTORY SEALED

C5302 RG C5302 FS
D5302 RG D5302 FS

5-Inch Rubber Rolls

C6302 RG C6302 FS
D6302 RG D6302 FS

6-Inch Rubber Rolls

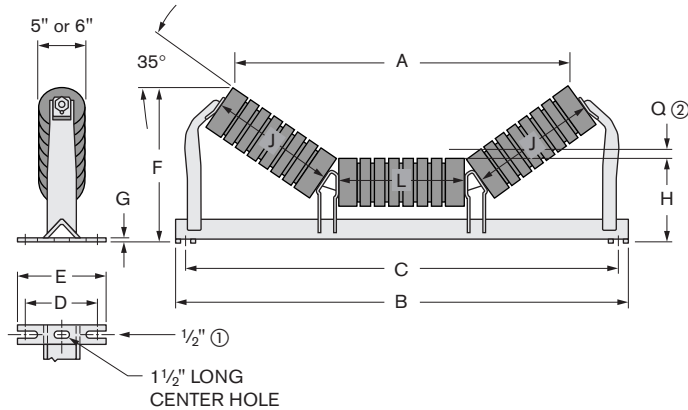

Dimensions in Inches — Average Weight in Pounds

Belt Width	A		B	C	D		E	F		G	H		J	L	Q	Idler Wgt. (Series C)	
	5\"	6\"			Recom.	Min.		5\"	6\"		5\"	6\"				5\"	6\"
	Roll	Roll						Roll	Roll		Roll	Roll					
18	18 ¹⁵ / ₁₆	18 ³ / ₈	29	27	7 ¹ / ₂	5 ³ / ₄	9 ¹ / ₄	12 ¹ / ₁₆	13 ¹ / ₁₆	5 ¹ / ₁₆	8 ⁹ / ₁₆	9 ¹ / ₁₆	7	7	1 ¹ / ₂	44	52
20	20 ¹⁵ / ₁₆	20 ³ / ₈	31	29	7 ¹ / ₂	5 ³ / ₄	9 ¹ / ₄	12 ¹ / ₁₆	13 ¹ / ₁₆	5 ¹ / ₁₆	8 ⁹ / ₁₆	9 ¹ / ₁₆	7	9	1 ¹ / ₂	48	57
24	24 ³ / ₁₆	23 ³ / ₈	35	33	7 ¹ / ₂	5 ³ / ₄	9 ¹ / ₄	13 ¹³ / ₁₆	14 ³ / ₈	5 ¹ / ₁₆	8 ⁹ / ₁₆	9 ¹ / ₁₆	9	9	2 ¹ / ₈	52	61
30	29 ⁷ / ₁₆	28 ⁷ / ₈	41	39	7 ¹ / ₂	5 ³ / ₄	9 ¹ / ₄	14 ¹⁵ / ₁₆	15 ⁵ / ₈	5 ¹ / ₁₆	8 ⁹ / ₁₆	9 ¹ / ₁₆	11	11	2 ¹¹ / ₁₆	61	72
36	34 ³ / ₄	34 ³ / ₁₆	47	45	7 ¹ / ₂	5 ³ / ₄	9 ¹ / ₄	16 ¹ / ₈	16 ⁹ / ₁₆	3 ¹ / ₁₆	8 ¹¹ / ₁₆	9 ⁹ / ₁₆	13	13	3 ¹ / ₄	73	82
42	40	39 ⁷ / ₁₆	53	51	7 ¹ / ₂	5 ³ / ₄	9 ¹ / ₄	17 ⁷ / ₈	18	5 ¹ / ₁₆	9	9 ¹ / ₂	15	15	3 ³ / ₁₆	81	92
48	45 ⁵ / ₁₆	44 ³ / ₄	59	57	7 ¹ / ₂	5 ³ / ₄	9 ¹ / ₄	18 ³ / ₄	19 ⁹ / ₁₆	5 ¹ / ₁₆	9	9 ¹ / ₂	17	17	4 ⁷ / ₁₆	94	105
54	50 ⁹ / ₁₆	50	65 ¹ / ₂	63	9	6 ³ / ₈	11 ¹ / ₂	20 ¹ / ₄	20 ¹¹ / ₁₆	3 ⁵ / ₈	9 ¹ / ₄	9 ³ / ₄	19	19	5	105	120
60	55 ⁷ / ₈	55 ¹ / ₄	71 ¹ / ₂	69	9	6 ³ / ₈	11 ¹ / ₂	21 ⁷ / ₁₆	21 ¹³ / ₁₆	3 ⁵ / ₈	9 ¹ / ₄	9 ³ / ₄	21	21	5 ⁹ / ₁₆	119	135
72	66 ¹ / ₄	65 ⁷ / ₈	83 ¹ / ₂	81	9	6 ¹ / ₄	11 ¹ / ₂	24	24 ¹ / ₂	3 ⁵ / ₈	9 ¹¹ / ₁₆	10 ³ / ₁₆	25	25	6 ¹ / ₁₆	145	161

① Use washers on 1/2-inch bolts.

□ Shaded sizes are most commonly used and are more readily available.

② Location of head pulley in relation to idler center roll.

Note: Dimensions subject to change. Certified dimensions of ordered material furnished on request.

REX IDLERS

SERIES C and D

35° TROUGHING TRAINING IDLER — EQUAL LENGTH ROLLS

Positive Arm Type — Belt Travel One Direction Only

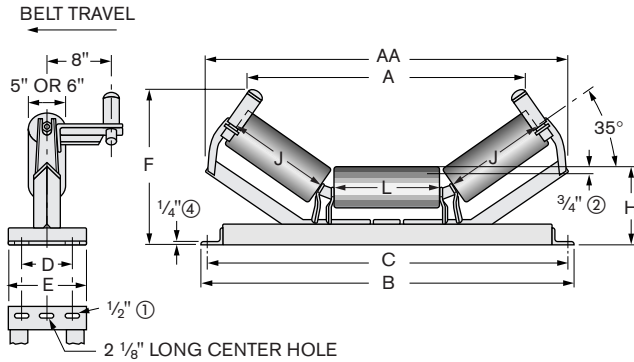

REGREASABLE FACTORY SEALED

C5312 RG C5312 FS
D5312 RG D5312 FS
5-Inch Steel Rolls

C6312 RG C6312 FS
D6312 RG D6312 FS
6-Inch Steel Rolls ③

Dimensions in Inches — Average Weight in Pounds

Belt Width	A	AA	B	C	D			E	F	H		J	L	Idler Wgt. (Series C)	
					Recom.	Min.	Max.			5" Dia.	6" Dia.			5"	6"
18	20	30 ¹³ / ₁₆	29	27	7 ¹ / ₂	5 ³ / ₄	8 ⁵ / ₈	10	16 ¹ / ₁₆	9 ¹ / ₄	9 ³ / ₄	7	7	104	116
20	22	32 ¹³ / ₁₆	31	29	7 ¹ / ₂	5 ³ / ₄	8 ⁵ / ₈	10	16 ¹ / ₁₆	9 ¹ / ₄	9 ³ / ₄	7	9	109	121
24	23 ¹³ / ₁₆	36 ¹ / ₈	35	33	7 ¹ / ₂	5 ³ / ₄	8 ⁵ / ₈	10	17	9 ¹ / ₄	9 ³ / ₄	9	9	120	132
30	29 ¹ / ₁₆	41 ³ / ₈	41	39	7 ¹ / ₂	5 ³ / ₄	8 ⁵ / ₈	10	18 ¹ / ₈	9 ¹ / ₄	9 ³ / ₄	11	11	135	147
36	35 ³ / ₄	46 ¹ / ₁₆	47	45	7 ¹ / ₂	5 ³ / ₄	8 ⁵ / ₈	10	19 ⁹ / ₁₆	9 ⁹ / ₁₆	9 ¹³ / ₁₆	13	13	149	162
42	41 ¹ / ₁₆	52 ³ / ₈	53	51	7 ¹ / ₂	5 ³ / ₄	10 ³ / ₄	14 ¹ / ₄	21 ¹ / ₄	9 ¹³ / ₁₆	10 ⁵ / ₁₆	15	15	166	178
48	46 ³ / ₁₆	57 ¹ / ₁₆	59	57	7 ¹ / ₂	5 ³ / ₄	10 ³ / ₄	14 ¹ / ₂	22 ³ / ₈	9 ¹³ / ₁₆	10 ⁹ / ₁₆	17	17	181	194
54	51 ⁵ / ₈	65 ³ / ₄	65	63	9	5 ³ / ₄	10 ³ / ₄	14 ¹ / ₂	23 ³ / ₈	10 ¹⁰ / ₁₆	10 ¹¹ / ₁₆	19	19	196	209
60	56 ⁷ / ₈	68 ⁹ / ₁₆	71	69	9	5 ³ / ₄	10 ³ / ₄	14 ¹ / ₂	25	10 ¹⁰ / ₁₆	10 ¹¹ / ₁₆	21	21	212	225
72	67 ¹ / ₁₆	79 ⁹ / ₁₆	83	81	9 ¹ / ₂	5 ³ / ₄	10 ³ / ₄	16 ¹ / ₂	27 ³ / ₈	10 ¹⁰ / ₁₆	10 ¹¹ / ₁₆	25	25	231	244

① Use washers on 1/2-inch bolts.

□ Shaded sizes are most commonly used and are more readily available.

② Approximate distance to the top of the center roll of other idlers.

③ Available in 1/4" roll wall thickness.

④ .31"-.72" belt width

35° TROUGHING TRAINING IDLER — EQUAL LENGTH ROLLS

Actuating Shoe Type — Belt Travel Either Direction

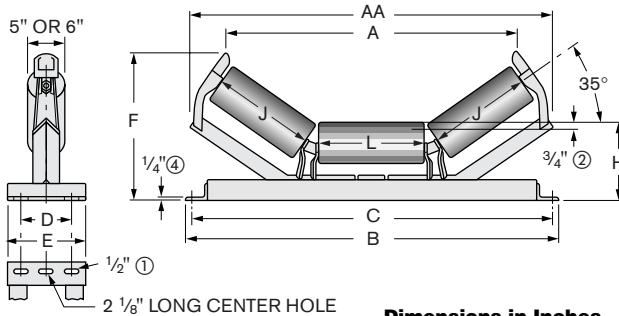

REGREASABLE FACTORY SEALED

C5310 RG C5310 FS
D5310 RG D5310 FS
5-Inch Steel Rolls

C6310 RG C6310 FS
D6310 RG D6310 FS
6-Inch Steel Rolls ③

Dimensions in Inches — Average Weight in Pounds

Belt Width	A		AA	B	C	D			E	F		H		J	L	Idler Wgt. (Series C)	
	5" Roll	6" Roll				Recom.	Min.	Max.		5" Dia.	6" Dia.	5" Dia.	6" Dia.			5"	6"
18	20 ³ / ₈	19 ¹ / ₁₆	30 ¹³ / ₁₆	29	27	7 ¹ / ₂	5 ³ / ₄	8 ⁵ / ₈	10	15 ¹ / ₁₆	16	9 ¹ / ₄	9 ³ / ₄	7	7	102	114
20	22 ³ / ₈	21 ¹ / ₁₆	32 ¹³ / ₁₆	31	29	7 ¹ / ₂	5 ³ / ₄	8 ⁵ / ₈	10	15 ¹ / ₁₆	16	9 ¹ / ₄	9 ³ / ₄	7	9	107	119
24	25 ⁵ / ₈	24 ⁵ / ₁₆	36 ¹ / ₈	35	33	7 ¹ / ₂	5 ³ / ₄	8 ⁵ / ₈	10	16 ¹ / ₄	17 ¹ / ₈	9 ¹ / ₄	9 ³ / ₄	9	9	118	130
30	30 ¹³ / ₁₆	29 ⁹ / ₁₆	41 ³ / ₈	41	39	7 ¹ / ₂	5 ³ / ₄	8 ⁵ / ₈	10	17 ⁷ / ₈	18 ¹ / ₄	9 ¹ / ₄	9 ³ / ₄	11	11	133	145
36	36 ³ / ₁₆	34 ⁷ / ₈	46 ¹ / ₁₆	47	45	7 ¹ / ₂	5 ³ / ₄	8 ⁵ / ₈	10	18 ¹ / ₈	19	9 ⁹ / ₁₆	9 ¹³ / ₁₆	13	13	147	160
42	41 ¹ / ₂	40 ⁹ / ₁₆	52 ³ / ₈	53	51	7 ¹ / ₂	5 ³ / ₄	10 ³ / ₄	14 ¹ / ₂	20 ¹ / ₄	21 ¹ / ₈	9 ¹³ / ₁₆	10 ⁵ / ₁₆	15	15	163	176
48	46 ³ / ₄	45 ⁷ / ₁₆	57 ¹ / ₁₆	59	57	7 ¹ / ₂	5 ³ / ₄	10 ³ / ₄	14 ¹ / ₂	21 ³ / ₈	22 ⁵ / ₁₆	9 ¹³ / ₁₆	10 ⁹ / ₁₆	17	17	178	191
54	52	50 ³ / ₄	65 ³ / ₄	65	63	9	5 ³ / ₄	10 ³ / ₄	14 ¹ / ₂	22 ¹⁵ / ₁₆	23 ¹³ / ₁₆	10 ¹⁰ / ₁₆	10 ¹¹ / ₁₆	19	19	193	206
60	57 ⁷ / ₁₆	56	68 ⁹ / ₁₆	71	69	9	5 ³ / ₄	10 ³ / ₄	14 ¹ / ₂	24 ¹ / ₁₆	24 ¹ / ₁₆	10 ¹⁰ / ₁₆	10 ¹¹ / ₁₆	21	21	209	222
72	67 ⁷ / ₈	67 ³ / ₄	79 ⁹ / ₁₆	83	81	9 ¹ / ₂	5 ³ / ₄	10 ³ / ₄	16 ³ / ₄	26 ³ / ₄	27 ¹ / ₄	10 ¹⁰ / ₁₆	10 ¹¹ / ₁₆	25	25	227	240

① Use washers on 1/2-inch bolts.

□ Shaded sizes are most commonly used and are more readily available.

② Approximate distance to the top of the center roll of other idlers.

③ Available in 1/4" roll wall thickness.

④ .31"-.72" belt width

Note: Dimensions subject to change. Certified dimensions of ordered material furnished on request.

REX IDLERS

SERIES C and D

35° TROUGHING IDLER — UNEQUAL LENGTH ROLLS

REGREASABLE FACTORY SEALED

C5301 RG C5301 FS
D5301 RG D5301 FS

5-Inch Steel Rolls

C6301 RG C6301 FS
D6301 RG D6301 FS

6-Inch Steel Rolls ③

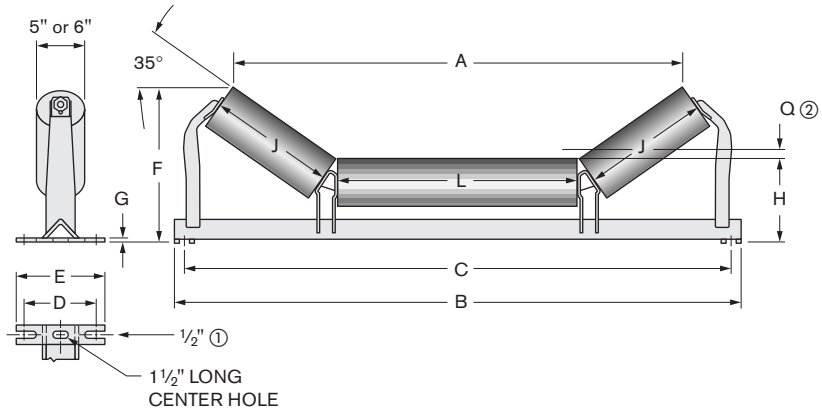

Dimensions in Inches — Average Weight in Pounds

Belt Width	A		B	C	D		E	F		G	H		J	L	Q	Idler Wgt. (Series C)			
	5" Roll	6" Roll			Recom.	Min.		5" Roll	6" Roll		5" Roll	6" Roll				5" Roll	6" Roll	5"	6"
30	30 ³ / ₁₆	29 ⁵ / ₁₆	41	39	7 ¹ / ₂	5 ³ / ₄	9 ¹ / ₄	13 ¹³ / ₁₆	14 ³ / ₁₆	5 ¹ / ₁₆	8 ⁹ / ₁₆	9 ¹ / ₁₆	9	15	2 ¹ / ₈	58	69		
36	36 ³ / ₁₆	35 ⁵ / ₁₆	47	45	7 ¹ / ₂	5 ³ / ₄	9 ¹ / ₄	13 ⁷ / ₁₆	14 ¹ / ₄	5 ¹ / ₁₆	8 ¹¹ / ₁₆	9 ⁹ / ₁₆	9	21	2 ¹ / ₈	69	78		
42	42 ³ / ₁₆	41 ⁵ / ₁₆	53	51	7 ¹ / ₂	5 ³ / ₄	9 ¹ / ₄	14 ³ / ₁₆	14 ⁹ / ₁₆	5 ¹ / ₁₆	9	9 ¹ / ₂	9	27	2 ¹ / ₈	77	88		
48	48 ³ / ₁₆	47 ⁵ / ₁₆	59	57	7 ¹ / ₂	5 ³ / ₄	9 ¹ / ₄	14 ³ / ₁₆	14 ⁹ / ₁₆	5 ¹ / ₁₆	9	9 ¹ / ₂	9	33	2 ¹ / ₈	90	101		
54	54 ³ / ₁₆	53 ⁵ / ₁₆	65 ¹ / ₂	63	9	6 ³ / ₈	11 ¹ / ₂	14 ⁹ / ₁₆	14 ¹⁵ / ₁₆	3 ³ / ₈	9 ¹ / ₄	9 ⁹ / ₁₆	9	39	2 ¹ / ₈	102	115		
60	60 ³ / ₁₆	59 ⁵ / ₁₆	71 ¹ / ₂	69	9	6 ³ / ₈	11 ¹ / ₂	14 ⁹ / ₁₆	14 ¹⁵ / ₁₆	3 ³ / ₈	9 ¹ / ₄	9 ⁹ / ₁₆	9	45	2 ¹ / ₈	114	130		
72	72 ³ / ₁₆	71 ⁵ / ₁₆	83 ¹ / ₂	81	9	7 ³ / ₄	11 ¹ / ₂	14 ⁷ / ₈	15 ¹ / ₄	3 ³ / ₈	9 ¹¹ / ₁₆	10 ³ / ₁₆	9	57	2 ¹ / ₈	129	145		

① Use washers on 1/2-inch bolts.

② Location of head pulley in relation to idler center roll.

③ Available in 1/4" roll wall thickness.

Contact Rexnord for load rating.

35° TROUGHING IMPACT IDLER — UNEQUAL LENGTH ROLLS

REGREASABLE FACTORY SEALED

C5303 RG C5303 FS
D5303 RG D5303 FS

5-Inch Rubber Rolls

C6303 RG C6303 FS
D6303 RG D6303 FS

6-Inch Rubber Rolls

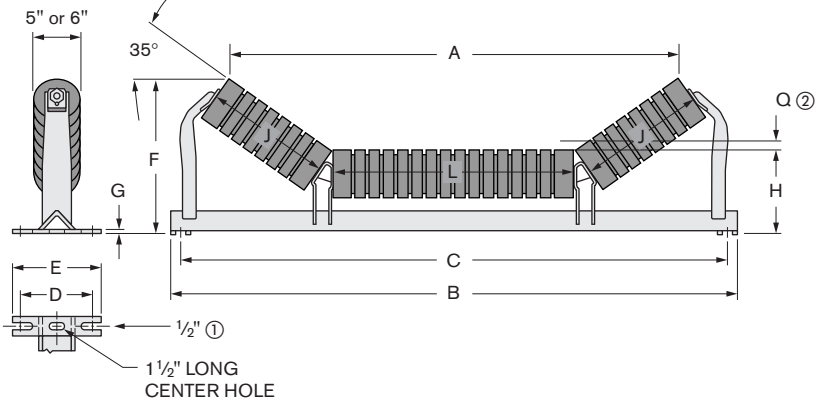

Dimensions in Inches — Average Weight in Pounds

Belt Width	A		B	C	D		E	F		G	H		J	L	Q	Idler Wgt. (Series C)			
	5" Roll	6" Roll			Recom.	Min.		5" Roll	6" Roll		5" Roll	6" Roll				5" Roll	6" Roll	5"	6"
30	30 ³ / ₁₆	29 ⁵ / ₁₆	41	39	7 ¹ / ₂	5 ³ / ₄	9 ¹ / ₄	13 ¹³ / ₁₆	14 ³ / ₁₆	5 ¹ / ₁₆	8 ⁹ / ₁₆	9 ¹ / ₁₆	9	15	2 ¹ / ₈	59	70		
36	36 ³ / ₁₆	35 ⁵ / ₁₆	47	45	7 ¹ / ₂	5 ³ / ₄	9 ¹ / ₄	13 ⁷ / ₁₆	14 ¹ / ₄	5 ¹ / ₁₆	8 ¹¹ / ₁₆	9 ⁹ / ₁₆	9	21	2 ¹ / ₈	70	79		
42	42 ³ / ₁₆	41 ⁵ / ₁₆	53	51	7 ¹ / ₂	5 ³ / ₄	9 ¹ / ₄	14 ³ / ₁₆	14 ⁹ / ₁₆	5 ¹ / ₁₆	9	9 ¹ / ₂	9	27	2 ¹ / ₈	79	90		
48	48 ³ / ₁₆	47 ⁵ / ₁₆	59	57	7 ¹ / ₂	5 ³ / ₄	9 ¹ / ₄	14 ³ / ₁₆	14 ⁹ / ₁₆	5 ¹ / ₁₆	9	9 ¹ / ₂	9	33	2 ¹ / ₈	92	103		
54	54 ³ / ₁₆	53 ⁵ / ₁₆	65 ¹ / ₂	63	9	6 ³ / ₈	11 ¹ / ₂	14 ⁹ / ₁₆	14 ¹⁵ / ₁₆	3 ³ / ₈	9 ¹ / ₄	9 ⁹ / ₁₆	9	39	2 ¹ / ₈	105	118		
60	60 ³ / ₁₆	59 ⁵ / ₁₆	71 ¹ / ₂	69	9	6 ³ / ₈	11 ¹ / ₂	14 ⁹ / ₁₆	14 ¹⁵ / ₁₆	3 ³ / ₈	9 ¹ / ₄	9 ⁹ / ₁₆	9	45	2 ¹ / ₈	117	133		
72	72 ³ / ₁₆	71 ⁵ / ₁₆	83 ¹ / ₂	81	9	7 ³ / ₄	11 ¹ / ₂	14 ⁷ / ₈	15 ¹ / ₄	3 ³ / ₈	9 ¹¹ / ₁₆	10 ³ / ₁₆	9	57	2 ¹ / ₈	132	147		

① Use washers on 1/2-inch bolts.

② Location of head pulley in relation to idler center roll.

Contact Rexnord for load rating.

Note: Dimensions subject to change. Certified dimensions of ordered material furnished on request.

REX IDLERS

SERIES C and D

35° TROUGHING TRAINING IDLER — UNEQUAL LENGTH ROLLS

Positive Arm Type — Belt Travel One Direction Only

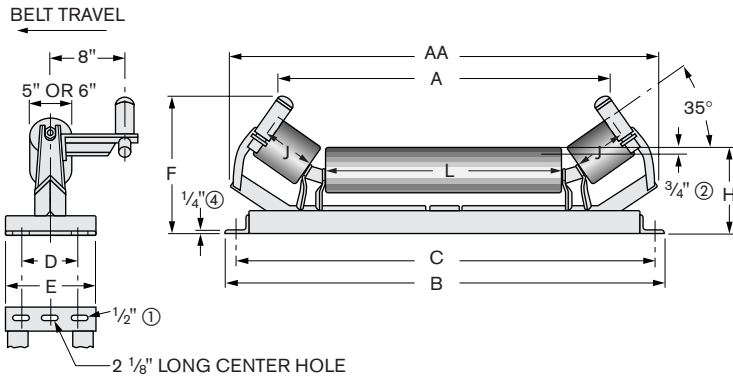

REGREASABLE	FACTORY SEALED
C5313 RG	C5313 FS
D5313 RG	D5313 FS
<i>5-Inch Steel Rolls</i>	
C6313 RG	C6313 FS
D6313 RG	D6313 FS
<i>6-Inch Steel Rolls</i> ③	

Dimensions in Inches — Average Weight in Pounds

Belt Width	A	AA	B	C	D			E	F	H		J	L	Idler Wgt. (Series C)	
					Recom.	Min.	Max.			5" Roll	6" Roll			5"	6"
30	31 1/4	42 1/8	41	39	7 1/2	5 3/4	8 5/8	10	17 5/16	9 1/4	9 3/4	9	15	135	147
36	37 1/4	48 1/8	47	45	7 1/2	5 3/4	8 5/8	10	17 3/8	9 5/16	9 13/16	9	21	149	162
42	43 1/4	54 5/8	53	51	7 1/2	5 3/4	10 3/4	14 1/2	17 7/8	9 13/16	10 5/16	9	27	166	178
48	49 1/4	60 9/16	59	57	7 1/2	5 3/4	10 3/4	14 1/2	17 7/8	9 13/16	10 5/16	9	33	181	194
54	55 1/4	66 7/8	65	63	9	5 3/4	10 3/4	14 1/2	18 1/4	10 3/16	10 11/16	9	39	196	209
60	61 1/4	72 7/8	71	69	9	5 3/4	10 3/4	14 1/2	18 1/4	10 3/16	10 11/16	9	45	212	225
72	72 1/4	85 1/4	83	81	9 1/2	5 3/4	10 3/4	16 1/2	18 1/4	10 3/16	10 11/16	9	57	231	243

- ① Use washers on 1/2-inch bolts.
 - ② Approximate distance to the top of the center roll of other idlers.
 - ③ Available in 1/4" roll wall thickness.
 - ④ .31"-72" belt width
- Contact Rexnord for load rating.

35° TROUGHING TRAINING IDLER — UNEQUAL LENGTH ROLLS

Actuating Shoe Type — Belt Travel Either Direction

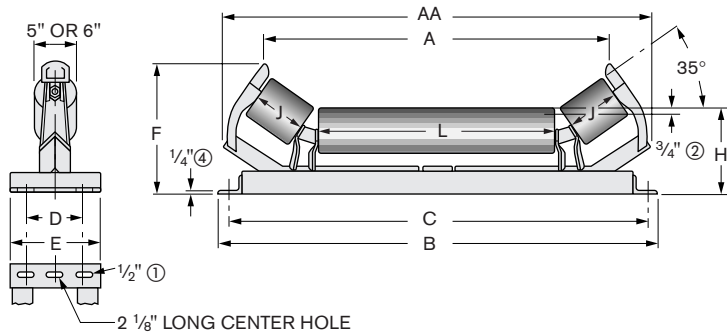

REGREASABLE	FACTORY SEALED
C5311 RG	C5311 FS
D5311 RG	D5311 FS
<i>5-Inch Steel Rolls</i>	
C6311 RG	C6311 FS
D6311 RG	D6311 FS
<i>6-Inch Steel Rolls</i> ③	

Dimensions in Inches — Average Weight in Pounds

Belt Width	A		AA	B	C	D			E	F		H		J	L	Idler Wgt. (Series C)	
	5" Roll	6" Roll				Recom.	Min.	Max.		5" Roll	6" Roll	5" Roll	6" Roll			5"	6"
30	31 5/16	30 5/16	42 1/8	41	39	7 1/2	5 3/4	8 5/8	10	16 5/16	17 1/8	9 1/4	9 3/4	9	15	132	145
36	37 5/16	36 5/16	48 1/8	47	45	7 1/2	5 3/4	8 5/8	10	16 3/8	17 3/8	9 5/16	9 3/4	9	21	147	160
42	43 5/16	46 5/16	54 1/8	53	51	7 1/2	5 3/4	10 3/4	14 1/2	16 7/8	17 11/16	9 13/16	10 5/16	9	27	163	176
48	49 5/16	48 5/16	60 9/16	59	57	7 1/2	5 3/4	10 3/4	14 1/2	16 7/8	17 11/16	9 13/16	10 5/16	9	33	178	191
54	55 5/16	54 5/16	66 7/8	65	63	9	5 3/4	10 3/4	14 1/2	17 1/4	18 1/16	10 3/16	10 11/16	9	39	193	206
60	61 5/16	60 5/16	72 7/8	71	69	9	5 3/4	10 3/4	14 1/2	17 1/4	18 1/16	10 3/16	10 11/16	9	45	209	222
72	73 5/16	72 1/2	85 1/4	83	81	9 1/2	5 3/4	10 3/4	16 1/2	17 1/2	18 5/8	10 3/16	10 11/16	9	57	229	240

- ① Use washers on 1/2-inch bolts.
 - ② Approximate distance to the top of the center roll of other idlers.
 - ③ Available in 1/4" roll wall thickness.
 - ④ .31"-72" belt width
- Contact Rexnord for load rating.

Note: Dimensions subject to change. Certified dimensions of ordered material furnished on request.

REX IDLERS

SERIES C and D

45° TROUGHING IDLER — EQUAL LENGTH ROLLS

REGREASABLE FACTORY SEALED

C5400 RG C5400 FS
D5400 RG D5400 FS

5-Inch Steel Rolls

C6400 RG C6400 FS
D6400 RG D6400 FS

6-Inch Steel Rolls ③

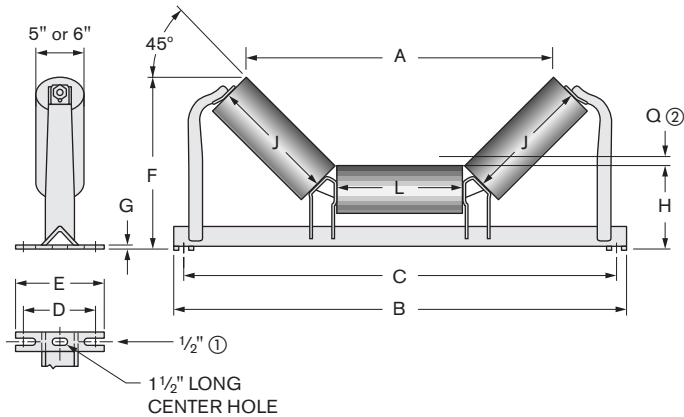

Dimensions in Inches — Average Weight in Pounds

Belt Width	A		B	C	D		E	F		G	H		J	L	Q	Idler Wgt. (Series C)	
	5" Roll	6" Roll			Recom.	Min.		5" Roll	6" Roll		5" Roll	6" Roll				5" Roll	6" Roll
18	17 ¹ / ₁₆	17	29	27	7 ¹ / ₂	5 ³ / ₄	9 ¹ / ₄	13 ³ / ₈	14	5 ¹ / ₁₆	8 ⁹ / ₁₆	9 ¹ / ₁₆	7	7	1 ¹⁵ / ₁₆	45	51
20	19 ¹ / ₁₆	19	31	29	7 ¹ / ₂	5 ³ / ₄	9 ¹ / ₄	13 ³ / ₈	14	5 ¹ / ₁₆	8 ⁹ / ₁₆	9 ¹ / ₁₆	7	9	1 ¹⁵ / ₁₆	49	57
24	22 ¹ / ₄	21 ⁹ / ₁₆	35	33	7 ¹ / ₂	5 ³ / ₄	9 ¹ / ₄	15 ¹ / ₁₆	15 ³ / ₈	5 ¹ / ₁₆	8 ⁹ / ₁₆	9 ¹ / ₁₆	9	9	2 ¹ / ₂	53	62
30	27 ¹ / ₁₆	26 ³ / ₈	41	39	7 ¹ / ₂	5 ³ / ₄	9 ¹ / ₄	16 ⁷ / ₁₆	16 ¹³ / ₁₆	5 ¹ / ₁₆	8 ⁹ / ₁₆	9 ¹ / ₁₆	11	11	3 ¹ / ₂	61	72
36	31 ¹⁵ / ₁₆	31 ³ / ₁₆	47	45	7 ¹ / ₂	5 ³ / ₄	9 ¹ / ₄	17 ¹⁵ / ₁₆	18 ⁵ / ₁₆	5 ¹ / ₁₆	8 ¹¹ / ₁₆	9 ⁹ / ₁₆	13	13	3 ⁷ / ₈	72	81
42	36 ³ / ₄	36 ¹ / ₁₆	53	51	7 ¹ / ₂	5 ³ / ₄	9 ¹ / ₄	19 ⁹ / ₁₆	20	5 ¹ / ₁₆	9	9 ¹ / ₂	15	15	4 ⁹ / ₁₆	80	92
48	41 ¹ / ₁₆	40 ⁷ / ₈	59	57	7 ¹ / ₂	5 ³ / ₄	9 ¹ / ₄	21 ¹ / ₁₆	21 ⁷ / ₁₆	5 ¹ / ₁₆	9	9 ¹ / ₂	17	17	5 ¹ / ₄	94	105
54	46 ³ / ₈	45 ¹ / ₁₆	65 ¹ / ₂	63	9	6 ³ / ₈	11 ¹ / ₂	22 ⁷ / ₁₆	23 ³ / ₁₆	3 ¹ / ₈	9 ¹ / ₄	9 ³ / ₄	19	19	5 ¹⁵ / ₁₆	106	119
60	51 ¹ / ₄	50 ¹ / ₂	71 ¹ / ₂	69	9	6 ³ / ₈	11 ¹ / ₂	24 ¹ / ₄	24 ⁵ / ₈	3 ¹ / ₈	9 ¹ / ₄	9 ³ / ₄	21	21	6 ³ / ₈	117	134
72	60 ¹⁵ / ₁₆	60 ¹ / ₄	83 ¹ / ₂	81	9	7 ³ / ₄	11 ¹ / ₂	27 ¹ / ₂	27 ¹³ / ₁₆	3 ¹ / ₈	9 ¹¹ / ₁₆	10 ³ / ₁₆	25	25	7 ¹ / ₈	146	163

① Use washers on 1/2-inch bolts.

② Location of head pulley in relation to idler center roll.

③ Available in 1/4" roll wall thickness.

□ Shaded sizes are most commonly used and are more readily available.

45° TROUGHING IMPACT IDLER — EQUAL LENGTH ROLLS

REGREASABLE FACTORY SEALED

C5402 RG C5402 FS
D5402 RG D5402 FS

5-Inch Rubber Rolls

C6402 RG C6402 FS
D6402 RG D6402 FS

6-Inch Rubber Rolls

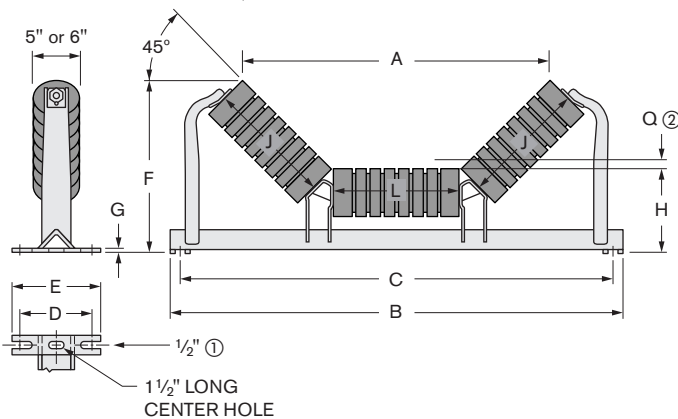

Dimensions in Inches — Average Weight in Pounds

Belt Width	A		B	C	D		E	F		G	H		J	L	Q	Idler Wgt. (Series C)	
	5" Roll	6" Roll			Recom.	Min.		5" Roll	6" Roll		5" Roll	6" Roll				5"	6"
18	17 ¹ / ₁₆	17	29	27	7 ¹ / ₂	5 ³ / ₄	9 ¹ / ₄	13 ³ / ₈	14	5 ¹ / ₁₆	8 ⁹ / ₁₆	9 ¹ / ₁₆	7	7	1 ¹⁵ / ₁₆	47	54
20	19 ¹ / ₁₆	19	31	29	7 ¹ / ₂	5 ³ / ₄	9 ¹ / ₄	13 ³ / ₈	14	5 ¹ / ₁₆	8 ⁹ / ₁₆	9 ¹ / ₁₆	7	9	1 ¹⁵ / ₁₆	51	60
24	22 ¹ / ₄	21 ⁹ / ₁₆	35	33	7 ¹ / ₂	5 ³ / ₄	9 ¹ / ₄	15 ¹ / ₁₆	15 ³ / ₈	5 ¹ / ₁₆	8 ⁹ / ₁₆	9 ¹ / ₁₆	9	9	2 ¹ / ₂	55	65
30	27 ¹ / ₁₆	26 ³ / ₈	41	39	7 ¹ / ₂	5 ³ / ₄	9 ¹ / ₄	16 ⁷ / ₁₆	16 ¹³ / ₁₆	5 ¹ / ₁₆	8 ⁹ / ₁₆	9 ¹ / ₁₆	11	11	3 ¹ / ₂	64	75
36	31 ¹⁵ / ₁₆	31 ³ / ₁₆	47	45	7 ¹ / ₂	5 ³ / ₄	9 ¹ / ₄	17 ¹⁵ / ₁₆	18 ⁵ / ₁₆	5 ¹ / ₁₆	8 ¹¹ / ₁₆	9 ⁹ / ₁₆	13	13	3 ⁷ / ₈	75	84
42	36 ³ / ₄	36 ¹ / ₁₆	53	51	7 ¹ / ₂	5 ³ / ₄	9 ¹ / ₄	19 ⁹ / ₁₆	20	5 ¹ / ₁₆	9	9 ¹ / ₂	15	15	4 ⁹ / ₁₆	84	96
48	41 ¹ / ₁₆	40 ⁷ / ₈	59	57	7 ¹ / ₂	5 ³ / ₄	9 ¹ / ₄	21 ¹ / ₁₆	21 ⁷ / ₁₆	5 ¹ / ₁₆	9	9 ¹ / ₂	17	17	5 ¹ / ₄	98	109
54	46 ³ / ₈	45 ¹ / ₁₆	65 ¹ / ₂	63	9	6 ³ / ₈	11 ¹ / ₂	22 ⁷ / ₁₆	23 ³ / ₁₆	3 ¹ / ₈	9 ¹ / ₄	9 ³ / ₄	19	19	5 ¹⁵ / ₁₆	110	123
60	51 ¹ / ₄	50 ¹ / ₂	71 ¹ / ₂	69	9	6 ³ / ₈	11 ¹ / ₂	24 ¹ / ₄	24 ⁵ / ₈	3 ¹ / ₈	9 ¹ / ₄	9 ³ / ₄	21	21	6 ³ / ₈	121	139
72	60 ¹⁵ / ₁₆	60 ¹ / ₄	83 ¹ / ₂	81	9	7 ³ / ₄	11 ¹ / ₂	27 ¹ / ₂	27 ¹³ / ₁₆	3 ¹ / ₈	9 ¹¹ / ₁₆	10 ³ / ₁₆	25	25	7 ¹ / ₈	148	167

① Use washers on 1/2-inch bolts.

② Location of head pulley in relation to idler center roll.

□ Shaded sizes are most commonly used and are more readily available.

Note: Dimensions subject to change. Certified dimensions of ordered material furnished on request.

REX IDLERS

SERIES C and D

45° TROUGHING TRAINING IDLER — EQUAL LENGTH ROLLS

Positive Arm Type — Belt Travel One Direction Only

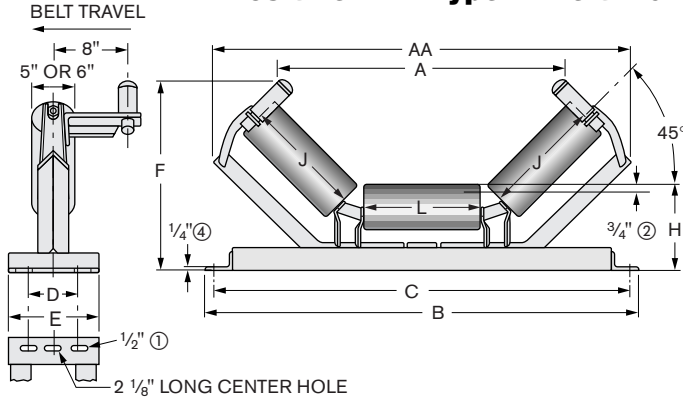

REGREASABLE	FACTORY SEALED
C5412 RG	C5412 FS
D5412 RG	D5412 FS
5-Inch Steel Rolls	
C6412 RG	C6412 FS
D6412 RG	D6412 FS
6-Inch Steel Rolls (3)	

Dimensions in Inches — Average Weight in Pounds

Belt Width	A	AA	B	C	D			E	F	H		J	L	Idler Wgt. (Series C)	
					Recom.	Min.	Max.			5" Roll	6" Roll			5"	6"
18	17 ³ / ₄	31 ⁷ / ₈	29	27	7 ¹ / ₂	5 ³ / ₄	8 ⁵ / ₈	10	17 ¹ / ₁₆	9 ¹ / ₄	9 ³ / ₄	7	7	106	118
20	19 ³ / ₄	33 ⁷ / ₈	31	29	7 ¹ / ₂	5 ³ / ₄	8 ⁵ / ₈	10	17 ¹ / ₁₆	9 ¹ / ₄	9 ³ / ₄	7	9	111	123
24	22 ⁹ / ₁₆	36 ³ / ₁₆	35	33	7 ¹ / ₂	5 ³ / ₄	8 ⁵ / ₈	10	18 ¹ / ₂	9 ¹ / ₄	9 ³ / ₄	9	9	122	134
30	27 ³ / ₈	41 ³ / ₈	41	39	7 ¹ / ₂	5 ³ / ₄	8 ⁵ / ₈	10	20	9 ¹ / ₄	9 ³ / ₄	11	11	137	149
36	32 ³ / ₁₆	46 ¹ / ₄	47	45	7 ¹ / ₂	5 ³ / ₄	8 ⁵ / ₈	10	21 ³ / ₈	9 ⁵ / ₁₆	9 ¹³ / ₁₆	13	13	149	164
42	37	51 ¹ / ₁₆	53	51	7 ¹ / ₂	5 ³ / ₄	10 ³ / ₄	14 ¹ / ₂	22 ³ / ₁₆	9 ¹³ / ₁₆	10 ⁵ / ₁₆	15	15	169	181
48	41 ⁷ / ₈	56 ³ / ₈	59	57	7 ¹ / ₂	5 ³ / ₄	10 ³ / ₄	14 ¹ / ₂	24 ³ / ₄	9 ¹³ / ₁₆	10 ⁵ / ₁₆	17	17	183	196
54	46 ¹ / ₁₆	61 ³ / ₈	65	63	9	5 ³ / ₄	10 ³ / ₄	14 ¹ / ₂	26 ¹ / ₂	10 ³ / ₁₆	10 ¹¹ / ₁₆	19	19	198	212
60	51 ¹ / ₂	66 ⁷ / ₁₆	71	69	9	5 ³ / ₄	10 ³ / ₄	14 ¹ / ₂	27 ¹⁵ / ₁₆	10 ³ / ₁₆	10 ¹¹ / ₁₆	21	21	215	227
72	60 ¹ / ₄	76 ³ / ₈	83	81	9 ¹ / ₂	5 ³ / ₄	10 ³ / ₄	16 ¹ / ₂	30 ¹ / ₂	10 ³ / ₁₆	10 ¹¹ / ₁₆	25	25	254	263

① Use washers on 1/2-inch bolts.

② Approximate distance to the top of the center roll of other idlers.

③ Available in 1/4" roll wall thickness.

④ .31"-.72" belt width

□ Shaded sizes are most commonly used and are more readily available.

45° TROUGHING TRAINING IDLER — EQUAL LENGTH ROLLS

Actuating Shoe Type — Belt Travel Either Direction

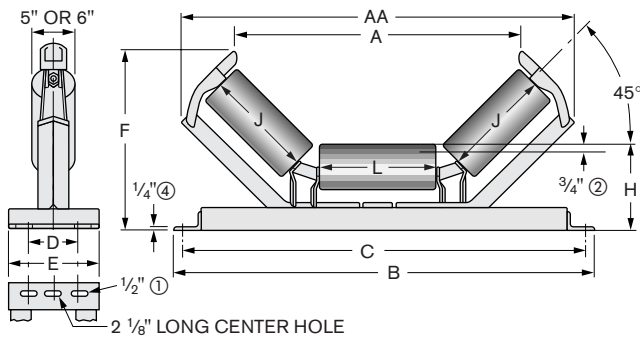

REGREASABLE	FACTORY SEALED
C5410 RG	C5410 FS
D6410 RG	C5410 FS
5-Inch Steel Rolls	
C6410 RG	C6410 FS
D6410 RG	D5410 FS
6-Inch Steel Rolls (3)	

Dimensions in Inches — Average Weight in Pounds

Belt Width	A		AA	B	C	D			E	F		H		J	L	Idler Wgt. (Series C)	
	5" Roll	6" Roll				Recom.	Min.	Max.		5" Roll	6" Roll	5" Roll	6" Roll			5"	6"
18	18 ¹ / ₄	16 ³ / ₈	31 ⁷ / ₈	29	27	7 ¹ / ₂	5 ³ / ₄	8 ⁵ / ₈	10	16 ³ / ₁₆	16 ¹⁵ / ₁₆	9 ¹ / ₄	9 ³ / ₄	7	7	104	116
20	20 ¹ / ₄	18 ³ / ₈	33 ⁷ / ₈	31	29	7 ¹ / ₂	5 ³ / ₄	8 ⁵ / ₈	10	16 ³ / ₁₆	16 ¹⁵ / ₁₆	9 ¹ / ₄	9 ³ / ₄	7	9	109	121
24	22 ⁹ / ₁₆	21 ¹ / ₂	35 ⁹ / ₁₆	35	33	7 ¹ / ₂	5 ³ / ₄	8 ⁵ / ₈	10	17 ⁹ / ₁₆	18 ⁵ / ₁₆	9 ¹ / ₄	9 ³ / ₄	9	9	120	132
30	27 ¹ / ₈	26 ³ / ₁₆	41 ³ / ₈	41	39	7 ¹ / ₂	5 ³ / ₄	8 ⁵ / ₈	10	19 ¹ / ₁₆	19 ³ / ₁₆	9 ¹ / ₄	9 ³ / ₄	11	11	135	147
36	32 ³ / ₄	31 ³ / ₈	46 ¹ / ₄	47	45	7 ¹ / ₂	5 ³ / ₄	8 ⁵ / ₈	10	20 ⁷ / ₁₆	21 ¹ / ₄	9 ⁵ / ₁₆	9 ¹³ / ₁₆	13	13	147	162
42	37 ¹ / ₁₆	35 ¹⁵ / ₁₆	51 ¹ / ₁₆	53	51	7 ¹ / ₂	5 ³ / ₄	10 ³ / ₄	14 ¹ / ₂	22 ³ / ₈	23 ¹ / ₈	9 ¹³ / ₁₆	10 ⁵ / ₁₆	15	15	165	178
48	42 ³ / ₈	40 ¹³ / ₁₆	56 ³ / ₈	59	57	7 ¹ / ₂	5 ³ / ₄	10 ³ / ₄	14 ¹ / ₂	23 ³ / ₄	24 ³ / ₁₆	9 ¹³ / ₁₆	10 ⁵ / ₁₆	17	17	180	193
54	47 ¹ / ₄	45 ⁵ / ₈	61 ³ / ₈	65	63	9	5 ³ / ₄	10 ³ / ₄	14 ¹ / ₂	25 ³ / ₁₆	26 ⁵ / ₁₆	10 ³ / ₁₆	10 ¹¹ / ₁₆	19	19	195	208
60	52 ¹ / ₁₆	50 ⁷ / ₁₆	66 ⁷ / ₁₆	71	69	9	5 ³ / ₄	10 ³ / ₄	14 ¹ / ₂	27	27 ³ / ₄	10 ³ / ₁₆	10 ¹¹ / ₁₆	21	21	211	224
72	62 ³ / ₁₆	60 ³ / ₄	76 ³ / ₈	83	81	9 ¹ / ₂	5 ³ / ₄	10 ³ / ₄	16 ¹ / ₂	29 ¹³ / ₁₆	30 ⁹ / ₁₆	10 ³ / ₁₆	10 ¹¹ / ₁₆	25	25	249	260

① Use washers on 1/2-inch bolts.

② Approximate distance to the top of the center roll of other idlers.

③ Available in 1/4" roll wall thickness.

④ .31"-.72" belt width

□ Shaded sizes are most commonly used and are more readily available.

Note: Dimensions subject to change. Certified dimensions of ordered material furnished on request.

REX IDLERS

SERIES C and D

45° TROUGHING IDLER — UNEQUAL LENGTH ROLLS

REGREASABLE FACTORY SEALED

C5401 RG C5401 FS
D5401 RG D5401 FS

5-Inch Steel Rolls

C6401 RG C6401 FS
D6401 RG D6401 FS

6-Inch Steel Rolls ③

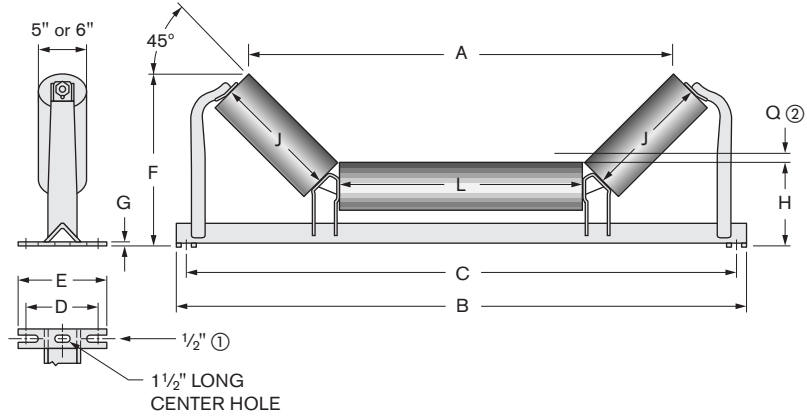

Dimensions in Inches — Average Weight in Pounds

Belt Width	A		B	C	D		E	F		G	H		J	L	Q	Idler Wgt. (Series C)	
	5" Roll	6" Roll			Recom.	Min.		5" Roll	6" Roll		5" Roll	6" Roll				5"	6"
	30	28 1/4			27 9/16	41		39	7 1/2		5 3/4	9 3/4				15 1/16	15 3/8
36	34 1/4	33 3/16	47	45	7 1/2	5 3/4	9 3/4	15 1/8	15 7/16	5/16	8 11/16	9 3/16	9	21	2 1/2	75	79
42	40 1/4	39 9/16	53	51	7 1/2	5 3/4	9 3/4	15 7/16	15 3/4	5/16	9	9 1/2	9	27	2 1/2	82	91
48	46 1/4	45 9/16	59	57	7 1/2	5 3/4	9 3/4	15 7/16	15 3/4	5/16	9	9 1/2	9	33	2 1/2	91	101
54	52 1/4	51 9/16	65 1/2	63	9	6 3/8	11 1/2	15 13/16	16 1/8	3/8	9 1/4	9 3/4	9	39	2 1/2	102	115
60	58 1/4	57 9/16	71 1/2	69	9	6 3/8	11 1/2	15 13/16	16 1/8	3/8	9 1/4	9 3/4	9	45	2 1/2	114	130
72	70 1/4	69 9/16	83 1/2	81	9	7 3/4	11 1/2	15 13/16	16 1/8	3/8	9 1 1/16	10 3/16	9	57	2 1/2	141	157

① Use washers on 1/2-inch bolts.

② Location of head pulley in relation to idler center roll.

③ Available in 1/4" roll wall thickness.

Contact Rexnord for load rating.

45° TROUGHING IMPACT IDLER — UNEQUAL LENGTH ROLLS

REGREASABLE FACTORY SEALED

C5403 RG C5403 FS
D5403 RG D5403 FS

5-Inch Rubber Rolls

C6403 RG C6403 FS
D6403 RG D6403 FS

6-Inch Rubber Rolls

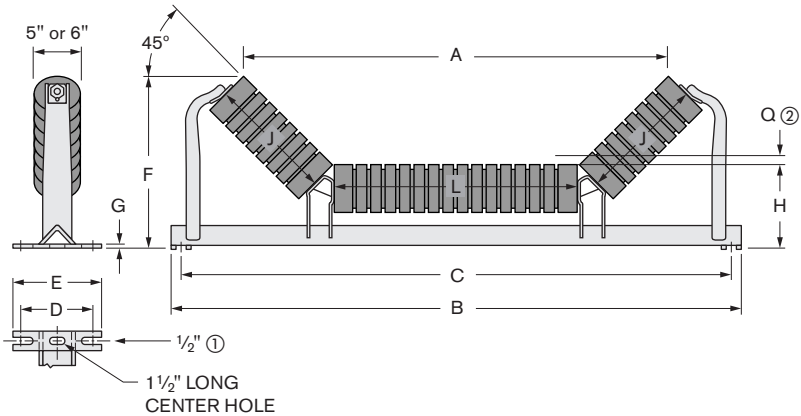

Dimensions in Inches — Average Weight in Pounds

Belt Width	A		B	C	D		E	F		G	H		J	L	Q	Idler Wgt. (Series C)	
	5" Roll	6" Roll			Recom.	Min.		5" Roll	6" Roll		5" Roll	6" Roll				5"	6"
	30	28 1/4			27 9/16	41		39	7 1/2		5 3/4	9 3/4				15 1/16	15 3/8
36	34 1/4	33 3/16	47	45	7 1/2	5 3/4	9 3/4	15 1/8	15 7/16	5/16	8 11/16	9 3/16	9	21	2 1/2	73	82
42	40 1/4	39 9/16	53	51	7 1/2	5 3/4	9 3/4	15 7/16	15 3/4	5/16	9	9 1/2	9	27	2 1/2	81	93
48	46 1/4	45 9/16	53	57	7 1/2	5 3/4	9 3/4	15 7/16	15 3/4	5/16	9	9 1/2	9	33	2 1/2	95	106
54	52 1/4	51 9/16	65 1/2	63	9	6 3/8	11 1/2	15 13/16	16 1/8	3/8	9 1/4	9 3/4	9	39	2 1/2	106	119
60	58 1/4	57 9/16	71 1/2	69	9	6 3/8	11 1/2	15 13/16	16 1/8	3/8	9 1/4	9 3/4	9	45	2 1/2	117	135
72	70 1/4	69 9/16	83 1/2	81	9	7 3/4	11 1/2	15 13/16	16 1/8	3/8	9 1 1/16	10 3/16	9	57	2 1/2	143	161

① Use washers on 1/2-inch bolts.

② Location of head pulley in relation to idler center roll.

Contact Rexnord for load rating.

Note: Dimensions subject to change. Certified dimensions of ordered material furnished on request.

REX IDLERS

SERIES C and D

45° TROUGHING TRAINING IDLER — UNEQUAL LENGTH ROLLS

Positive Arm Type — Belt Travel One Direction Only

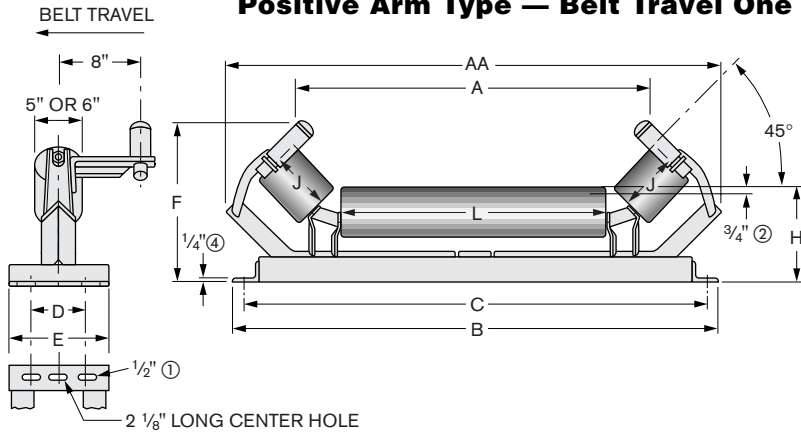

REGREASABLE FACTORY SEALED

C5413 RG C5413 FS
D5413 RG D5413 FS

5-Inch Steel Rolls

C6413 RG C6413 FS
D6413 RG D6413 FS

6-Inch Steel Rolls ③

Dimensions in Inches — Average Weight in Pounds

Belt Width	A	AA	B	C	D			E	F	H		J	L	Idler Wgt. (Series C)	
					Recom.	Min.	Max.			5" Roll	6" Roll			5"	6"
30	28 ⁹ / ₁₆	42 ⁹ / ₁₆	41	39	7 ¹ / ₂	5 ³ / ₄	8 ⁵ / ₈	10	18 ¹ / ₂	9 ¹ / ₄	9 ³ / ₄	9	15	135	147
36	34 ⁹ / ₁₆	48 ⁵ / ₈	47	45	7 ¹ / ₂	5 ³ / ₄	8 ⁵ / ₈	10	18 ⁵ / ₁₆	9 ⁵ / ₁₆	9 ¹³ / ₁₆	9	21	147	162
42	40 ⁹ / ₁₆	55 ¹ / ₁₆	53	51	7 ¹ / ₂	5 ³ / ₄	10 ³ / ₄	14 ¹ / ₂	19 ¹ / ₁₆	9 ¹³ / ₁₆	10 ⁵ / ₁₆	9	27	166	180
48	46 ⁹ / ₁₆	61 ¹ / ₁₆	59	57	7 ¹ / ₂	5 ³ / ₄	10 ³ / ₄	14 ¹ / ₂	19 ¹ / ₁₆	9 ¹³ / ₁₆	10 ⁵ / ₁₆	9	33	180	193
54	52 ⁹ / ₁₆	67 ¹ / ₂	65	63	9	5 ³ / ₄	10 ³ / ₄	14 ¹ / ₂	19 ⁷ / ₁₆	10 ³ / ₁₆	10 ¹¹ / ₁₆	9	39	194	208
60	58 ⁹ / ₁₆	73 ¹ / ₂	71	69	9	5 ³ / ₄	10 ³ / ₄	14 ¹ / ₂	19 ⁷ / ₁₆	10 ³ / ₁₆	10 ¹¹ / ₁₆	9	45	211	223
72	69 ⁹ / ₁₆	86	83	81	9 ¹ / ₂	5 ³ / ₄	10 ³ / ₄	16 ¹ / ₂	19 ⁷ / ₁₆	10 ³ / ₁₆	10 ¹¹ / ₁₆	9	57	248	259

① Use washers on 1/2-inch bolts.

② Approximate distance to the top of the center roll of other idlers.

③ Available in 1/4" roll wall thickness.

④ .31"-.72" belt width

Contact Rexnord for load rating.

45° TROUGHING TRAINING IDLER — UNEQUAL LENGTH ROLLS

Actuating Shoe Type — Belt Travel Either Direction

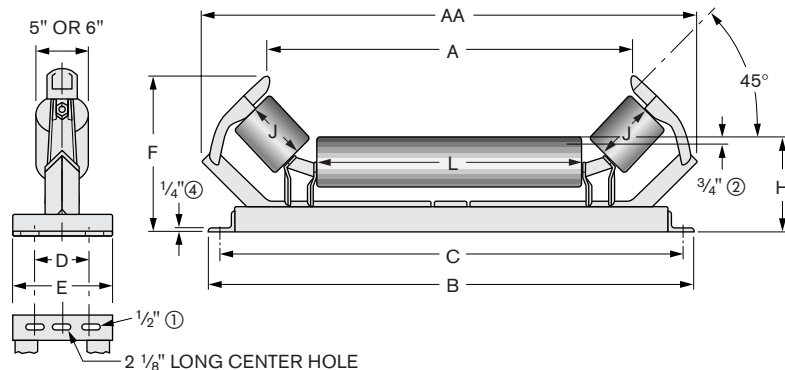

REGREASABLE FACTORY SEALED

C5411 RG C5411 FS
D5411 RG D5411 FS

5-Inch Steel Rolls

C6411 RG C6411 FS
D6411 RG D6411 FS

6-Inch Steel Rolls ③

Dimensions in Inches — Average Weight in Pounds

Belt Width	A		AA	B	C	D			E	F		H		J	L	Idler Wgt. (Series C)	
	5" Roll	6" Roll				Recom.	Min.	Max.		5" Roll	6" Roll	5" Roll	6" Roll			5"	6"
30	29 ¹ / ₁₆	27 ¹ / ₂	42 ⁹ / ₁₆	41	39	7 ¹ / ₂	5 ³ / ₄	8 ⁵ / ₈	10	17 ⁹ / ₁₆	18 ⁵ / ₁₆	9 ¹ / ₄	9 ³ / ₄	9	15	133	145
36	35 ¹ / ₁₆	33 ¹ / ₂	48 ⁵ / ₈	47	45	7 ¹ / ₂	5 ³ / ₄	8 ⁵ / ₈	10	17 ⁵ / ₈	18 ⁵ / ₈	9 ⁵ / ₁₆	9 ¹³ / ₁₆	9	21	145	160
42	41 ¹ / ₁₆	39 ¹ / ₂	55 ¹ / ₁₆	53	51	7 ¹ / ₂	5 ³ / ₄	10 ³ / ₄	14 ¹ / ₂	18 ¹ / ₄	18 ⁵ / ₈	9 ¹³ / ₁₆	10 ⁵ / ₁₆	9	27	162	177
48	47 ¹ / ₁₆	45 ¹ / ₂	61 ¹ / ₁₆	59	57	7 ¹ / ₂	5 ³ / ₄	10 ³ / ₄	14 ¹ / ₂	18 ¹ / ₄	18 ⁵ / ₈	9 ¹³ / ₁₆	10 ⁵ / ₁₆	9	33	177	190
54	53 ¹ / ₁₆	51 ¹ / ₂	67 ¹ / ₂	65	63	9	5 ³ / ₄	10 ³ / ₄	14 ¹ / ₂	18 ⁵ / ₈	19 ¹ / ₄	10 ³ / ₁₆	10 ¹¹ / ₁₆	9	39	191	204
60	59 ¹ / ₁₆	57 ¹ / ₂	73 ¹ / ₂	71	69	9	5 ³ / ₄	10 ³ / ₄	14 ¹ / ₂	18 ⁵ / ₈	19 ¹ / ₄	10 ³ / ₁₆	10 ¹¹ / ₁₆	9	45	207	220
72	71 ¹ / ₁₆	69 ¹ / ₂	80 ⁹ / ₁₆	83	81	9 ¹ / ₂	5 ³ / ₄	10 ³ / ₄	16 ¹ / ₂	18 ⁵ / ₈	19 ¹ / ₄	10 ³ / ₁₆	10 ¹¹ / ₁₆	9	57	241	255

① Use washers on 1/2-inch bolts.

② Approximate distance to the top of the center roll of other idlers.

③ Available in 1/4" roll wall thickness.

④ .31"-.72" belt width

Contact Rexnord for load rating.

Note: Dimensions subject to change. Certified dimensions of ordered material furnished on request.

REX IDLERS

SERIES C and D

RETURN STEEL OR RUBBER IDLER

REGREASABLE	FACTORY SEALED	REGREASABLE	FACTORY SEALED
C5040 RG	C5040 FS	C5049 RG	C5049 FS
D5040 RG	D5040 FS	D5049 RG	D5049 FS
<i>5-Inch Steel Roll</i>		<i>5-Inch Rubber Roll</i>	
C6040 RG	C6040 FS	C6049 RG	C6049 FS
D6040 RG	D6040 FS	D6049 RG	D6049 FS
<i>6-Inch Steel Roll</i> ③		<i>6-Inch Rubber Roll</i>	

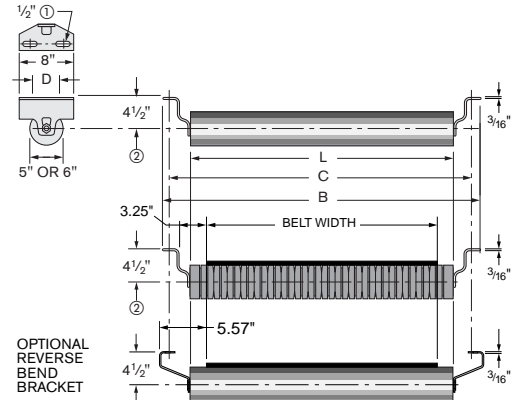

Dimensions in Inches — Average Weight in Pounds

Belt Width	B	C	D			L	Idler Wgt. and Thickness (Series C)				
			Recom.	Min.	Max.		5"		6"		
							Steel	Rubber	Steel	Steel	Rubber
							.149"	1.47"	.165"	.250"	1.97"
18	29	27	5	3 3/4	6 1/4	21	22	32	33	41	39
20	31	29	5	3 3/4	6 1/4	23	24	32	35	44	39
24	35	33	5	3 3/4	6 1/4	27	26	38	38	49	47
30	41	39	5	3 3/4	6 1/4	33	32	49	44	58	57
36	47	45	5	3 3/4	6 1/2	39	37	57	50	56	66
42	53	51	5	3 3/4	6 1/4	45	42	64	56	75	75
48	59	57	5	3 3/4	6 1/4	51	47	73	62	83	84
★54	65	63	5	3 3/4	6 1/4	57	58	85	70	95	92
★60	71	69	5	3 3/4	6 1/4	63	63	90	79	107	100
★72	83	81	5	3 3/4	6 1/4	75	74	106	93	126	116

① Use washers on 1/2-inch bolts.

② Available with 1 1/2, 1 1/4 or 1 3/8 inch drop.

③ Available in 1/4" roll wall thickness.

□ Shaded sizes are most commonly used and are more readily available.

★ These idlers are Series D only.

FLAT STEEL OR RUBBER IDLER

REGREASABLE	FACTORY SEALED	REGREASABLE	FACTORY SEALED
C5020 RG	C5020 FS	C5025 RG	C5025 FS
D5020 RG	D5020 FS	D5025 RG	D5025 FS
<i>5-Inch Steel Roll</i>		<i>5-Inch Rubber Roll</i>	
C6020 RG	C6020 FS	C6025 RG	C6025 FS
D6020 RG	D6020 FS	D6025 RG	D6025 FS
<i>6-Inch Steel Roll</i> ③		<i>6-Inch Rubber Roll</i>	

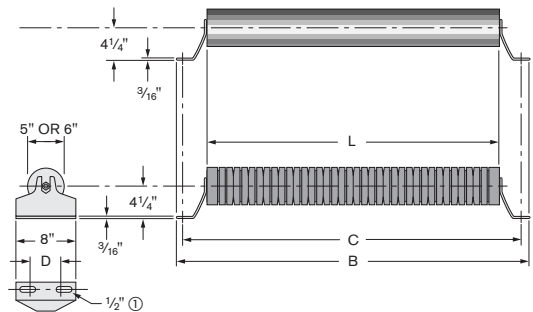

Dimensions in Inches — Average Weight in Pounds

Belt Width	B	C	D			L	Idler Wgt. and Thickness (Series C)				
			Recom.	Min.	Max.		5"		6"		
							Steel	Rubber	Steel	Steel	Rubber
							.149"	1.47"	.165"	.250"	1.97"
18	29	27	5	3 3/4	6 1/4	21	22	32	33	41	39
20	31	29	5	3 3/4	6 1/4	23	24	32	35	44	39
24	35	33	5	3 3/4	6 1/4	27	26	38	38	49	47
30	41	39	5	3 3/4	6 1/4	33	32	49	44	58	57
36	47	45	5	3 3/4	6 1/2	39	37	57	50	56	66
42	53	51	5	3 3/4	6 1/4	45	42	64	56	75	75
48	59	57	5	3 3/4	6 1/4	51	47	73	62	83	84
★54	65	63	5	3 3/4	6 1/4	57	58	85	70	95	92
★60	71	69	5	3 3/4	6 1/4	63	63	90	79	107	100
★72	83	81	5	3 3/4	6 1/4	75	74	106	93	126	116

① Use washers on 1/2-inch bolts.

□ Shaded sizes are most commonly used and are more readily available.

★ These idlers are Series D only.

Note: Dimensions subject to change. Certified dimensions of ordered material furnished on request.

REX IDLERS

SERIES C and D

RETURN TRAINING IDLER

Positive Arm Type — Belt Travel One Direction Only

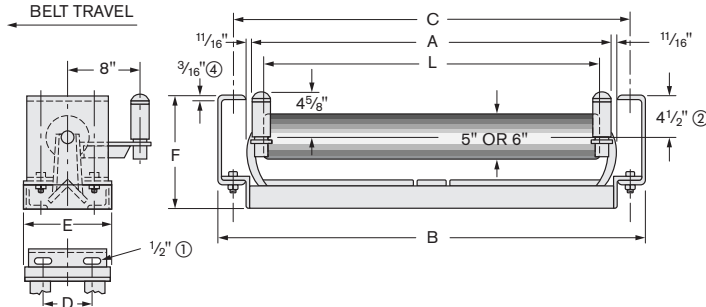

REGREASABLE FACTORY SEALED

C5052 RG C5052 FS
D5052 RG D5052 FS
5-Inch Steel Roll

C6052 RG C6052 FS
D6052 RG D6052 RG
6-Inch Steel Roll ③

Dimensions in Inches — Average Weight in Pounds

Belt Width	A	B	C	D			E	F	L	Idler Wgt. and Thickness (Series C)		
				Recom.	Min.	Max.				5"	6"	6"
										.149"	.165"	.250"
18	23 ⁵ / ₈	29 ¹ / ₂	27	5	3 ³ / ₄	6 ¹ / ₄	10	12 ¹ / ₂	21	90	105	114
20	25 ⁵ / ₈	31 ¹ / ₂	29	5	3 ³ / ₄	6 ¹ / ₄	10	12 ¹ / ₂	23	102	117	127
24	29 ⁵ / ₈	35 ¹ / ₂	33	5	3 ³ / ₄	6 ¹ / ₄	10	12 ¹ / ₂	27	110	129	140
30	35 ⁵ / ₈	41 ¹ / ₂	39	5	3 ³ / ₄	6 ¹ / ₄	10	12 ¹ / ₂	33	126	141	155
36	41 ⁵ / ₈	47 ¹ / ₂	45	5	3 ³ / ₄	6 ¹ / ₄	10	12 ¹ / ₂	39	148	153	169
42	47 ⁵ / ₈	53 ¹ / ₂	51	5	3 ³ / ₄	6 ¹ / ₄	14 ¹ / ₂	13	45	157	165	184
48	53 ⁵ / ₈	59 ¹ / ₂	57	5	3 ³ / ₄	6 ¹ / ₄	14 ¹ / ₂	13	51	167	182	204
★54	59 ⁵ / ₈	65 ¹ / ₂	63	5	3 ³ / ₄	6 ¹ / ₄	14 ¹ / ₂	13	57	178	192	216
★60	65 ⁵ / ₈	71 ¹ / ₂	69	5	3 ³ / ₄	6 ¹ / ₄	14 ¹ / ₂	13	63	188	200	227
★72	77 ⁵ / ₈	83 ¹ / ₂	81	5	3 ³ / ₄	6 ¹ / ₄	16 ¹ / ₂	13 ¹ / ₄	75	208	214	238

- ① Use washers on 1/2-inch bolts. □ Shaded sizes are most commonly used and are more readily available.
② Available with 1 1/2 or 1 1/4 inch drop. ★ These idlers are Series D only.
③ Available in 1/4" roll wall thickness.
④ 1/4"-.72" belt width

FLAT TRAINING IDLER

Positive Arm Type — Belt Travel One Direction Only

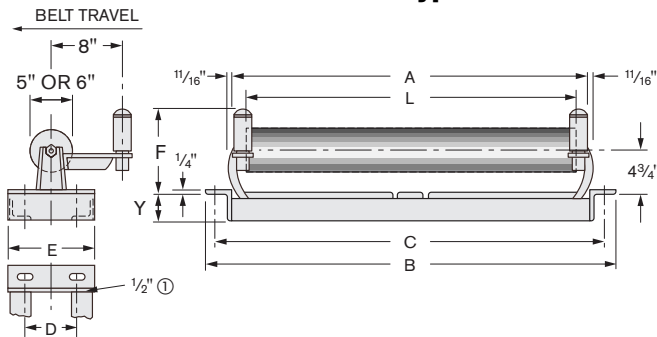

REGREASABLE FACTORY SEALED

C5031 RG C5031 FS
D5031 RG D5031 FS
5-Inch Steel Roll

C6031 RG C6031 FS
D6031 RG D6031 FS
6-Inch Steel Roll ②

Dimensions in Inches — Average Weight in Pounds

Belt Width	A	B	C	D			E	F	L	Y	Idler Wgt. and Thickness (Series C)		
				Recom.	Min.	Max.					5"	6"	6"
											.149"	.165"	.250"
18	23 ⁵ / ₈	28 ³ / ₄	27	5	3 ³ / ₄	6 ¹ / ₄	10	9 ³ / ₈	21	3 ³ / ₈	85	100	109
20	25 ⁵ / ₈	30 ³ / ₄	29	5	3 ³ / ₄	6 ¹ / ₄	10	9 ³ / ₈	23	3 ³ / ₈	97	112	122
24	29 ⁵ / ₈	34 ³ / ₄	33	5	3 ³ / ₄	6 ¹ / ₄	10	9 ³ / ₈	27	3 ¹ / ₂	105	124	135
30	35 ⁵ / ₈	40 ³ / ₄	39	5	3 ³ / ₄	6 ¹ / ₄	10	9 ³ / ₈	33	3 ¹ / ₂	121	136	150
36	41 ⁵ / ₈	46 ³ / ₄	45	5	3 ³ / ₄	6 ¹ / ₄	10	9 ³ / ₈	39	3 ¹ / ₂	143	148	165
42	47 ⁵ / ₈	52 ³ / ₄	51	5	3 ³ / ₄	6 ¹ / ₄	14 ¹ / ₂	9 ³ / ₈	45	3 ¹ / ₁₆	152	160	179
48	53 ⁵ / ₈	58 ³ / ₄	57	5	3 ³ / ₄	6 ¹ / ₄	14 ¹ / ₂	9 ³ / ₈	51	3 ¹ / ₁₆	162	177	199
★54	59 ⁵ / ₈	64 ³ / ₄	63	5	3 ³ / ₄	6 ¹ / ₄	14 ¹ / ₂	9 ³ / ₈	57	3 ⁹ / ₁₆	173	187	211
★60	65 ⁵ / ₈	70 ³ / ₄	69	5	3 ³ / ₄	6 ¹ / ₄	14 ¹ / ₂	9 ³ / ₈	63	3 ⁹ / ₁₆	183	198	225
★72	77 ⁵ / ₈	82 ³ / ₄	81	5	3 ³ / ₄	6 ¹ / ₄	16 ¹ / ₂	9 ³ / ₄	75	3 ⁹ / ₁₆	202	208	234

- ① Use washers on 1/2-inch bolts. □ Shaded sizes are most commonly used and are more readily available.
② Available in 1/4" roll wall thickness. ★ These idlers are Series D only.

Note: Dimensions subject to change. Certified dimensions of ordered material furnished on request.

REX IDLERS

SERIES C and D

RETURN TRAINING IDLER

Actuating Shoe Type — Belt Travel Either Direction

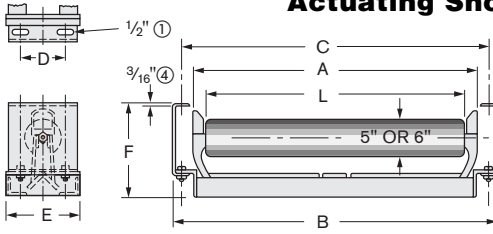

Dimensions in Inches — Average Weight in Pounds

Belt Width	A	B	C	Recom.	Min.	Max.	E	F	L	Idler Wgt. & Thick. (Series C)		
										5"	6"	6"
										.149"	.165"	.250"
18	24 $\frac{1}{8}$	29 $\frac{1}{2}$	27	5	3 $\frac{3}{4}$	6 $\frac{1}{4}$	10	12 $\frac{1}{2}$	21	88	102	111
20	26 $\frac{1}{8}$	31 $\frac{1}{2}$	29	5	3 $\frac{3}{4}$	6 $\frac{1}{4}$	10	12 $\frac{1}{2}$	23	100	115	125
24	30 $\frac{1}{8}$	35 $\frac{1}{2}$	33	5	3 $\frac{3}{4}$	6 $\frac{1}{4}$	10	12 $\frac{1}{2}$	27	112	127	139
30	36 $\frac{1}{8}$	41 $\frac{1}{2}$	39	5	3 $\frac{3}{4}$	6 $\frac{1}{4}$	10	12 $\frac{1}{2}$	33	125	139	153
36	42 $\frac{1}{8}$	47 $\frac{1}{2}$	45	5	3 $\frac{3}{4}$	6 $\frac{1}{4}$	10	12 $\frac{1}{2}$	39	146	151	167
42	48 $\frac{1}{8}$	53 $\frac{1}{2}$	51	5	3 $\frac{3}{4}$	6 $\frac{1}{4}$	14 $\frac{1}{2}$	13	45	152	163	182
48	54 $\frac{1}{8}$	59 $\frac{1}{2}$	57	5	3 $\frac{3}{4}$	6 $\frac{1}{4}$	14 $\frac{1}{2}$	13	51	165	180	201
★54	60 $\frac{1}{8}$	65 $\frac{1}{2}$	63	5	3 $\frac{3}{4}$	6 $\frac{1}{4}$	14 $\frac{1}{2}$	13	57	176	190	214
★60	66 $\frac{1}{8}$	71 $\frac{1}{2}$	69	5	3 $\frac{3}{4}$	6 $\frac{1}{4}$	14 $\frac{1}{2}$	13	63	186	201	227
★72	78 $\frac{1}{8}$	83 $\frac{1}{2}$	81	5	3 $\frac{3}{4}$	6 $\frac{1}{4}$	16 $\frac{1}{2}$	13 $\frac{15}{16}$	75	205	219	251

REGREASABLE FACTORY SEALED

C5051 RG C5051 FS
D5051 RG D5051 FS

5-Inch Steel Roll

C6051 RG C6051 FS
D6051 RG D6051 FS

6-Inch Steel Roll ③

- ① Use washers on 1/2-inch bolts.
- ② Available with 1 1/2 or 1 13/16 inch drop.
- ③ Available in 1/4" roll wall thickness.
- ④ 1/4"-.72" belt width
- ★ These idlers are Series D only.
- Shaded sizes are most commonly used and are more readily available.

RETURN TRAINING IDLER

Inclined Pivot Type — Belt Travel One Direction Only

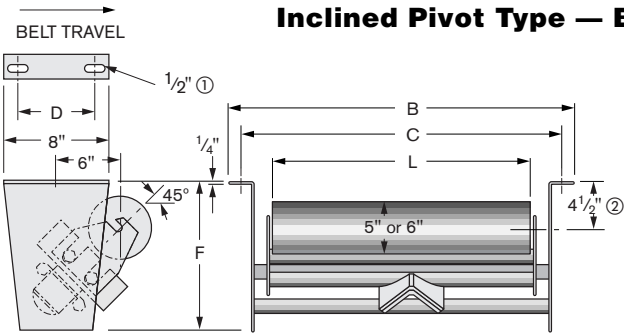

Dimensions in Inches — Average Weight in Pounds

Belt Width	B	C	D			F	L	Idler Wgt. & Thick. (Series C)		
			Recom.	Min.	Max.			5"	6"	6"
			.149"	.165"	.250"					
18	29	27	5	3 $\frac{3}{4}$	6 $\frac{1}{4}$	14 $\frac{3}{16}$	21	81	74	83
20	31	29	5	3 $\frac{3}{4}$	6 $\frac{1}{4}$	14 $\frac{3}{16}$	23	85	90	100
24	35	33	5	3 $\frac{3}{4}$	6 $\frac{1}{4}$	14 $\frac{3}{16}$	27	94	106	118
30	41	39	5	3 $\frac{3}{4}$	6 $\frac{1}{4}$	14 $\frac{3}{16}$	33	108	122	136
36	47	45	5	3 $\frac{3}{4}$	6 $\frac{1}{4}$	14 $\frac{3}{16}$	39	119	136	152
42	53	51	5	3 $\frac{3}{4}$	6 $\frac{1}{4}$	14 $\frac{3}{16}$	45	133	152	171
48	59	57	5	3 $\frac{3}{4}$	6 $\frac{1}{4}$	14 $\frac{3}{16}$	51	146	167	188
★54	65	63	5	3 $\frac{3}{4}$	6 $\frac{1}{4}$	14 $\frac{3}{16}$	57	185	199	223
★60	71	69	5	3 $\frac{3}{4}$	6 $\frac{1}{4}$	14 $\frac{3}{16}$	63	200	215	281
★72	83	81	5	3 $\frac{3}{4}$	6 $\frac{1}{4}$	14 $\frac{3}{16}$	75	231	247	279

REGREASABLE FACTORY SEALED

C5050 RG C5050 FS
D5050 RG D5050 FS

5-Inch Steel Roll

C6050 RG C6050 FS
D6050 RG D6050 FS

6-Inch Steel Roll ③

- ① Use washers on 1/2-inch bolts.
- ② Available with 1 1/2 or 1 13/16 inch drop.
- ③ Available in 1/4" roll wall thickness.
- ★ These idlers are Series D only.
- Shaded sizes are most commonly used and are more readily available.

FLAT TRAINING IDLER

Actuating Shoe Type — Belt Travel Either Direction

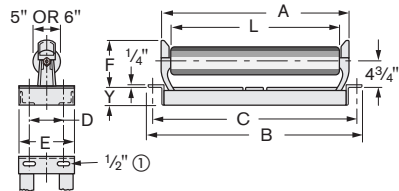

Dimensions in Inches — Average Weight in Pounds

Belt Width	A	B	C	D			E	F		L	Y	Idler Wgt. and Thick. (Series C)		
				Recom.	Min.	Max.		5" Dia.	6" Dia.			5"	6"	6"
				.149"	.165"	.250"								
18	24 $\frac{1}{8}$	28 $\frac{3}{4}$	27	5	3 $\frac{3}{4}$	6 $\frac{1}{4}$	10	8	9 $\frac{1}{8}$	21	3 $\frac{1}{8}$	83	98	107
20	26 $\frac{1}{8}$	30 $\frac{3}{4}$	29	5	3 $\frac{3}{4}$	6 $\frac{1}{4}$	10	8	9 $\frac{1}{8}$	23	3 $\frac{1}{8}$	95	110	120
24	30 $\frac{1}{8}$	34 $\frac{3}{4}$	33	5	3 $\frac{3}{4}$	6 $\frac{1}{4}$	10	8	9 $\frac{1}{8}$	27	3 $\frac{1}{8}$	107	122	134
30	36 $\frac{1}{8}$	40 $\frac{3}{4}$	39	5	3 $\frac{3}{4}$	6 $\frac{1}{4}$	10	8	9 $\frac{1}{8}$	33	3 $\frac{1}{8}$	120	134	148
36	42 $\frac{1}{8}$	46 $\frac{3}{4}$	45	5	3 $\frac{3}{4}$	6 $\frac{1}{4}$	10	8	9 $\frac{1}{8}$	39	3 $\frac{1}{8}$	141	146	162
42	48 $\frac{1}{8}$	52 $\frac{3}{4}$	51	5	3 $\frac{3}{4}$	6 $\frac{1}{4}$	14 $\frac{1}{2}$	8	9 $\frac{1}{8}$	45	3 $\frac{11}{16}$	147	158	177
48	54 $\frac{1}{8}$	58 $\frac{3}{4}$	57	5	3 $\frac{3}{4}$	6 $\frac{1}{4}$	14 $\frac{1}{2}$	8	9 $\frac{1}{8}$	51	3 $\frac{11}{16}$	160	175	196
★54	60 $\frac{1}{8}$	64 $\frac{3}{4}$	63	5	3 $\frac{3}{4}$	6 $\frac{1}{4}$	14 $\frac{1}{2}$	8	9 $\frac{1}{8}$	57	3 $\frac{9}{16}$	171	185	209
★60	66 $\frac{1}{8}$	70 $\frac{3}{4}$	69	5	3 $\frac{3}{4}$	6 $\frac{1}{4}$	14 $\frac{1}{2}$	8	9 $\frac{1}{8}$	63	3 $\frac{9}{16}$	181	196	222
★72	78 $\frac{1}{8}$	82 $\frac{3}{4}$	81	5	3 $\frac{3}{4}$	6 $\frac{1}{4}$	16 $\frac{1}{2}$	8	9 $\frac{1}{8}$	75	3 $\frac{9}{16}$	200	215	247

REGREASABLE FACTORY SEALED

C5030 RG C5030 FS
D5030 RG D5030 FS

5-Inch Steel Roll

C6030 RG C6030 FS
D6030 RG D6030 FS

6-Inch Steel Roll ②

- ① Use washers on 1/2-inch bolts.
- ② Available in 1/4" roll wall thickness.
- ★ These idlers are Series D only.
- Shaded sizes are most commonly used and are more readily available.

Note: Dimensions subject to change. Certified dimensions of ordered material furnished on request.

REX IDLERS

SERIES C and D

SPIRAL RETURN IDLER

Belt Travel One Direction Only

Rex Spiral Return Idlers minimize belt fleet and damage on the return belt which would otherwise result from material build-up. The correct direction of rotation is important and is clearly marked on each idler. The "V" formed by right-hand and left-hand spirals should point in the direction of rotation.

Dimensions in Inches — Average Weight in Pounds

Belt Width	B	C	D			L	Idler Wgt. (Series C)
			Recom.	Min.	Max.		
18	29	27	5	3 ³ / ₄	6 ¹ / ₄	21	20
20	31	29	5	3 ³ / ₄	6 ¹ / ₄	23	23
24	35	33	5	3 ³ / ₄	6 ¹ / ₄	27	25
30	41	39	5	3 ³ / ₄	6 ¹ / ₄	33	29
36	47	45	5	3 ³ / ₄	6 ¹ / ₄	39	34
42	53	51	5	3 ³ / ₄	6 ¹ / ₄	45	40
48	59	57	5	3 ³ / ₄	6 ¹ / ₄	51	45
★54	65	63	5	3 ³ / ₄	6 ¹ / ₄	57	58
★60	71	69	5	3 ³ / ₄	6 ¹ / ₄	63	67
★72	83	81	5	3 ³ / ₄	6 ¹ / ₄	75	85

① Use washers on 1/2-inch bolts.

② Available with 1 1/2, 1 1/4 or 1 1/2 inch drop.

★ These idlers are Series D only.

□ Shaded sizes are most commonly used and are more readily available.

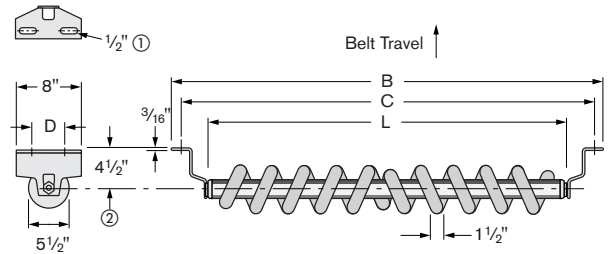

REGREASABLE FACTORY SEALED

C6042 RG
D6042 RG

C6042 FS
D6042 FS

5/2-Inch Rubber Spiral Roll

SPIRAL RETURN TRAINING IDLER

Positive Arm Type — Belt Travel One Direction Only

Dimensions in Inches — Average Weight in Pounds

Belt Width	A	B	C	D			E	F	L	Idler Wgt. (Series C)
				Recom.	Min.	Max.				
18	23 ⁵ / ₈	29 ¹ / ₂	27	5	3 ³ / ₄	6 ¹ / ₄	10	12 ¹ / ₂	21	88
20	25 ⁵ / ₈	31 ¹ / ₂	29	5	3 ³ / ₄	6 ¹ / ₄	10	12 ¹ / ₂	23	98
24	29 ⁵ / ₈	35 ¹ / ₂	33	5	3 ³ / ₄	6 ¹ / ₄	10	12 ¹ / ₂	27	110
30	35 ⁵ / ₈	41 ¹ / ₂	39	5	3 ³ / ₄	6 ¹ / ₄	10	12 ¹ / ₂	33	123
36	41 ⁵ / ₈	47 ¹ / ₂	45	5	3 ³ / ₄	6 ¹ / ₄	10	12 ¹ / ₂	39	135
42	47 ⁵ / ₈	53 ¹ / ₂	51	5	3 ³ / ₄	6 ¹ / ₄	14 ¹ / ₂	13	45	143
48	53 ⁵ / ₈	59 ¹ / ₂	57	5	3 ³ / ₄	6 ¹ / ₄	14 ¹ / ₂	13	51	159
★54	59 ⁵ / ₈	65 ¹ / ₂	63	5	3 ³ / ₄	6 ¹ / ₄	14 ¹ / ₂	13	57	169
★60	65 ⁵ / ₈	71 ¹ / ₂	69	5	3 ³ / ₄	6 ¹ / ₄	14 ¹ / ₂	13	63	179
★72	77 ⁵ / ₈	83 ¹ / ₂	81	5	3 ³ / ₄	6 ¹ / ₄	16 ¹ / ₂	13 ¹⁵ / ₁₆	75	197

① Use washers on 1/2-inch bolts.

② Available with 1 1/2 or 1 1/4 inch drop.

③ 1/4"-.72" belt width

★ These idlers are Series D only.

□ Shaded sizes are most commonly used and are more readily available.

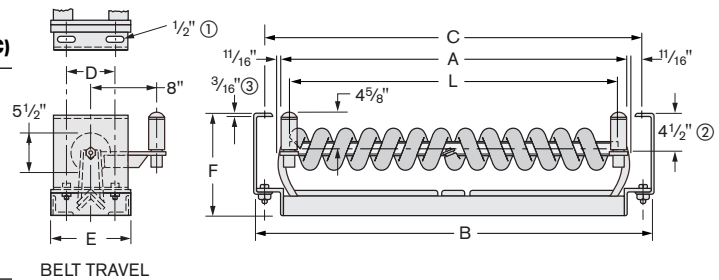

REGREASABLE FACTORY SEALED

C6057 RG
D6057 RG

C6057 FS
D6057 FS

5/2-Inch Rubber Spiral Roll

SPIRAL RETURN TRAINING IDLER

Inclined Pivot Type — Belt Travel One Direction Only

Dimensions in Inches — Average Weight in Pounds

Belt Width	B	C	D			F	L	Idler Wgt. (Series C)
			Recom.	Min.	Max.			
18	29	27	5	3 ³ / ₄	6 ¹ / ₄	14 ³ / ₁₆	21	76
20	31	29	5	3 ³ / ₄	6 ¹ / ₄	14 ³ / ₁₆	23	81
24	35	33	5	3 ³ / ₄	6 ¹ / ₄	14 ³ / ₁₆	27	90
30	41	39	5	3 ³ / ₄	6 ¹ / ₄	13 ³ / ₁₆	33	104
36	47	45	5	3 ³ / ₄	6 ¹ / ₄	14 ³ / ₁₆	39	115
42	53	51	5	3 ³ / ₄	6 ¹ / ₄	14 ³ / ₁₆	45	130
48	59	57	5	3 ³ / ₄	6 ¹ / ₄	14 ³ / ₁₆	51	144
★54	65	63	5	3 ³ / ₄	6 ¹ / ₄	14 ³ / ₁₆	57	173
★60	71	69	5	3 ³ / ₄	6 ¹ / ₄	14 ³ / ₁₆	63	188
★72	83	81	5	3 ³ / ₄	6 ¹ / ₄	14 ³ / ₁₆	75	215

① Use washers on 1/2-inch bolts.

② Available with 1 1/2 or 1 1/4 inch drop.

★ These idlers are Series D only.

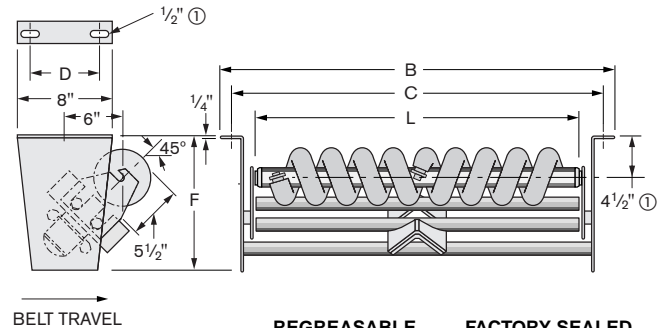

REGREASABLE FACTORY SEALED

C6053 RG
D6053 RG

C6053 FS
D6053 FS

5/2-Inch Rubber Spiral Roll

Note: Dimensions subject to change. Certified dimensions of ordered material furnished on request.

REX IDLERS

SERIES C and D

DISC RETURN IDLER

Rex Disc Return Idlers minimize belt misalignment which can cause damage to the belt, resulting from material build-up on the return idler rolls. Available with rubber, ceramic or urethane discs.

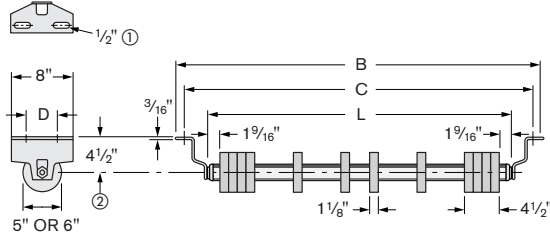

Four discs on each end is standard.

REGREASABLE FACTORY SEALED

C5043 RG C5043 FS
D6043 RG D5043 FS

5-Inch Disc Roll

C6043 RG C6043 FS
D6043 RG D5043 FS

6-Inch Disc Roll

Dimensions in Inches — Average Weight in Pounds

Belt Width	B	C	D			L	No. of Discs	Idler Wgt. (Series C)	
			Recom.	Min.	Max.			5"	6"
18	29	27	5	3 ³ / ₄	6 ¹ / ₄	21	9	20	26
20	31	29	5	3 ³ / ₄	6 ¹ / ₄	23	9	22	28
24	35	33	5	3 ³ / ₄	6 ¹ / ₄	27	10	24	30
30	41	39	5	3 ³ / ₄	6 ¹ / ₄	33	11	27	34
36	47	45	5	3 ³ / ₄	6 ¹ / ₄	39	12	31	37
42	53	51	5	3 ³ / ₄	6 ¹ / ₄	45	13	35	42
48	59	57	5	3 ³ / ₄	6 ¹ / ₄	51	14	41	48
★54	65	63	5	3 ³ / ₄	6 ¹ / ₄	57	15	49	56
★60	71	69	5	3 ³ / ₄	6 ¹ / ₄	63	16	54	62
★72	83	81	5	3 ³ / ₄	6 ¹ / ₄	75	18	65	73

① Use washers on 1/2-inch bolts.

② Available with 1 1/2, 1 1/4 or 1 1/8 inch drop.

★ These idlers are Series D only.

□ Shaded sizes are most commonly used and are more readily available.

DISC RETURN TRAINING IDLER Positive Arm Type — Belt Travel One Direction Only

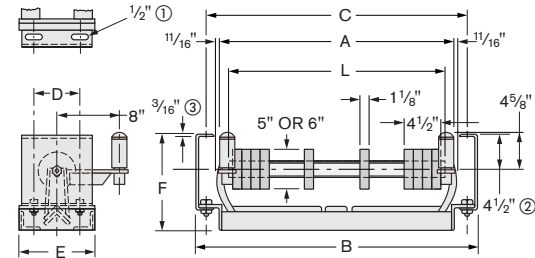

Four discs on each end is standard.

REGREASABLE FACTORY SEALED

C5056 RG C5056 FS
D5056 RG D5056 FS

5-Inch Disc Roll

C6056 RG C6056 FS
D6056 RG D6056 FS

6-Inch Disc Roll

Dimensions in Inches — Average Weight in Pounds

Belt Width	A	B	C	D			E	F	No. of Discs	L	Idler Wgt. (Series C)	
				Recom.	Min.	Max.					5"	6"
18	23 ³ / ₈	29 ¹ / ₂	27	5	3 ³ / ₄	6 ¹ / ₄	10	12 ¹ / ₂	9	21	94	97
20	25 ³ / ₈	31 ¹ / ₂	29	5	3 ³ / ₄	6 ¹ / ₄	10	12 ¹ / ₂	9	23	106	109
24	29 ³ / ₈	35 ¹ / ₂	33	5	3 ³ / ₄	6 ¹ / ₄	10	12 ¹ / ₂	10	27	118	121
30	35 ³ / ₈	41 ¹ / ₂	39	5	3 ³ / ₄	6 ¹ / ₄	10	12 ¹ / ₂	11	33	131	134
36	41 ³ / ₈	47 ¹ / ₂	45	5	3 ³ / ₄	6 ¹ / ₄	10	12 ¹ / ₂	12	39	143	146
42	47 ³ / ₈	53 ¹ / ₂	51	5	3 ³ / ₄	6 ¹ / ₄	14 ¹ / ₂	13	13	45	156	159
48	53 ³ / ₈	59 ¹ / ₂	57	5	3 ³ / ₄	6 ¹ / ₄	14 ¹ / ₂	13	14	51	167	171
★54	59 ³ / ₈	65 ¹ / ₂	63	5	3 ³ / ₄	6 ¹ / ₄	14 ¹ / ₂	13	15	57	183	187
★60	65 ³ / ₈	71 ¹ / ₂	69	5	3 ³ / ₄	6 ¹ / ₄	14 ¹ / ₂	13	16	63	195	199
★72	77 ³ / ₈	83 ¹ / ₂	81	5	3 ³ / ₄	6 ¹ / ₄	16 ¹ / ₂	13 ⁵ / ₁₆	18	75	216	221

① Use washers on 1/2-inch bolts.

② Available with 1 1/2 or 1 1/4 inch drop.

③ 1/4"-.72" belt width

★ These idlers are Series D only.

□ Shaded sizes are most commonly used and are more readily available.

DISC RETURN TRAINING IDLER Inclined Pivot Type — Belt Travel One Direction Only

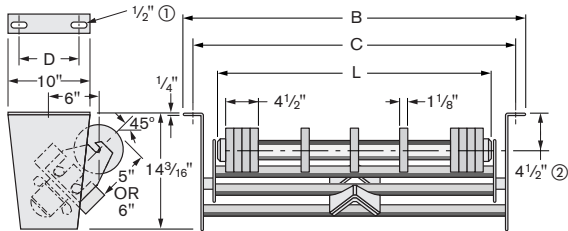

Four discs on each end is standard.

REGREASABLE FACTORY SEALED

C5054 RG C5054 FS
D5054 RG D5054 FS

5-Inch Disc Roll

C6054 RG C6054 FS
D6054 RG D6054 FS

6-Inch Disc Roll

Dimensions in Inches — Average Weight in Pounds

Belt Width	B	C	D			L	No. of Discs	Idler Wgt. (Series C)	
			Recom.	Min.	Max.			5"	6"
18	29	27	5	3 ³ / ₄	6 ¹ / ₄	21	9	67	69
20	31	29	5	3 ³ / ₄	6 ¹ / ₄	23	9	69	71
24	35	33	5	3 ³ / ₄	6 ¹ / ₄	27	10	73	76
30	41	39	5	3 ³ / ₄	6 ¹ / ₄	33	11	80	83
36	47	45	5	3 ³ / ₄	6 ¹ / ₄	39	12	106	109
42	53	51	5	3 ³ / ₄	6 ¹ / ₄	45	13	116	120
48	59	57	5	3 ³ / ₄	6 ¹ / ₄	51	14	127	131
★54	65	63	5	3 ³ / ₄	6 ¹ / ₄	57	15	161	165
★60	71	69	5	3 ³ / ₄	6 ¹ / ₄	63	16	174	178
★72	83	81	5	3 ³ / ₄	6 ¹ / ₄	75	18	197	202

① Use washers on 1/2-inch bolts.

② Available with 1 1/2 or 1 1/4 inch drop.

★ These idlers are Series D only.

□ Shaded sizes are most commonly used and are more readily available.

Note: Dimensions subject to change. Certified dimensions of ordered material furnished on request.

REX IDLERS

SERIES C and D

RIBBED COVERED RETURN IDLER

The REX RIBBED COVERED RETURN IDLERS are standard Rex return idlers covered with a tough extruded, one piece, ribbed rubber sleeve. The sleeve is offered in either a **straight-ribbed** or **chevron** pattern. The **straight-ribbed** idler acts as an effective belt beater removing carry-back from the underside of the belt. It comes

complete with special hangers for longer life. The **chevron ribbed** cover also removes material but runs smoothly without idler build-up making an effective return idler for severe operating conditions. Both styles offer "rubber on rubber" belt protection, prevent idler build-up, remove carry back and operate with dual direction bolts.



STRAIGHT RIBBED (S)



CHEVRON RIBBED (C)

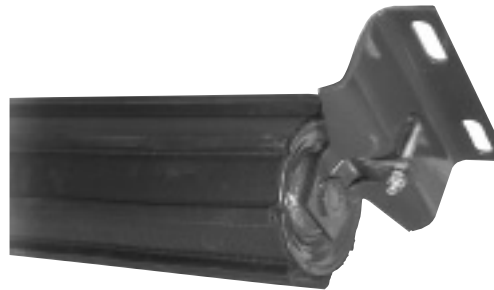

Only available with 4 1/2" drop bracket shown here with positive roll hold down clamp.

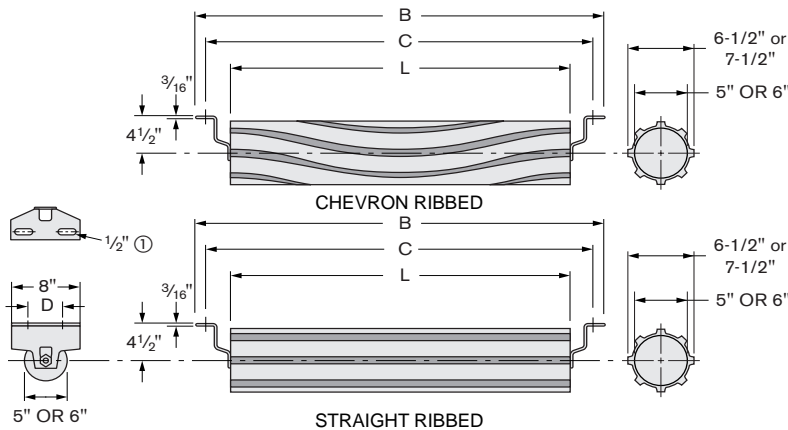

REGREASABLE	FACTORY SEALED
C5046 RG	C5046 FS
D5046 RG	D5046 FS
<i>6 1/2 Inch Rubber Roll</i>	
C6046 RG	C6046 FS
D6046 RG	D6046 FS
<i>7 1/2-Inch Rubber Roll</i>	

Dimensions in Inches — Average Weight in Pounds

Belt Width	B	C	D			L	Idler Wgt. (Series C)	
			Recom.	Min.	Max.		6 1/2" Roll	7 1/2" Roll
18	29	27	5	3 3/4	6 1/4	21	33	39
20	31	29	5	3 3/4	6 1/4	23	35	42
24	35	33	5	3 3/4	6 1/4	27	39	47
30	41	39	5	3 3/4	6 1/4	33	48	56
36	47	45	5	3 3/4	6 1/4	39	56	65
42	53	51	5	3 3/4	6 1/4	45	63	74
48	59	57	5	3 3/4	6 1/4	51	70	83
★54	65	63	5	3 3/4	6 1/4	57	84	92
★60	71	69	5	3 3/4	6 1/4	63	92	100
★72	83	81	5	3 3/4	6 1/4	75	98	108

① Use washers on 1/2-inch bolts.

Add suffix "C" for chevron and "S" for straight, i.e. 48-C6046RG-S.

□ Shaded sizes are most commonly used and are more readily available.

★ These idlers are Series D.

REX IDLERS

SERIES D

REX RIBBED® TRAINING IDLER

The REX RIBBED TRAINING IDLER functions by sensing misalignment and immediately reacting to it. A Rex cartridge self-aligning roller bearing centered inside the rubber covered steel roll provides a rugged pivot. The cartridge bearing is well protected with "M" seals and by its location inside the roll. The tough ribbed rubber cover helps eliminate material build-up. The REX RIBBED TRAINING IDLER is especially effective on reversing conveyors.

Model D6058 7 1/2-Inch Rubber Roll

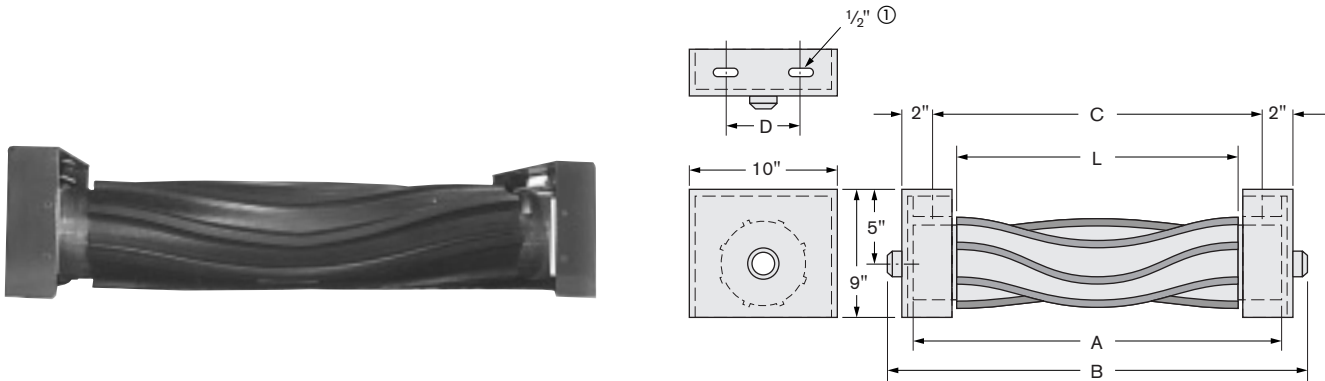

The REX RIBBED TRAINING IDLER utilizes a steel six inch diameter hollow tube. This tube is placed into a fluted rubber sleeve which is 7 1/2" diameter. The rubber sleeve has a chevron pattern for superior training.

Dimensions in Inches — Average Weight in Pounds

Belt Width	A	B	C	D			L	Idler Wgt.
				Recom.	Min.	Max.		
24	36	38½	33	4	3¼	8¼	29½	93
30	42	44½	39	4	3¼	8¼	35½	103
36	48	50½	45	4	3¼	8¼	41½	115
42	54	56½	51	4	3¼	8¼	47½	127
48	60	62½	57	4	3¼	8¼	53½	138
54	66	68½	63	4	3¼	8¼	59½	154
60	72	74½	69	4	3¼	8¼	65½	165
72	84	86½	81	4	3¼	8¼	77½	183

① Use washers on ½" bolts.

□ Shaded sizes are most commonly used and are more readily available.

REX IDLERS

SERIES C and D

V - RETURN IDLER - 15°

Factory Sealed

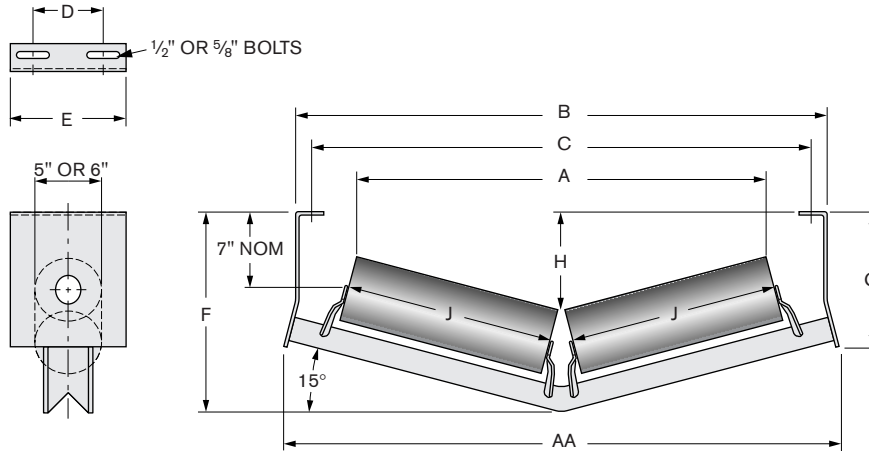

C5140V15 FS D5140V15 FS
5-Inch Disc Roll

C6140V15 FS D6140V15 FS
6-Inch Disc Roll

Dimensions in Inches — Average Weight in Pounds

Belt Width	A		AA	B	C	A			E	F	G	H		J	Idler Wgt. (Series C)	
	5" Roll	6" Roll				Recom.	Min.	Max				5" Roll	6" Roll		5"	6"
18	21½	21¼	32¼	30	27	6¼	¾	8½	10	16¼	12½	7½	7	11	59	62
20	21½	21¼	34¼	32	29	6¼	¾	8½	10	16¼	12½	7½	7	11	60	63
24	25¾	25½	38¼	36	33	6¼	¾	8½	10	16¾	12½	8	7½	13	66	70
30	33½	32¾	44¼	42	39	6¼	¾	8½	10	17¾	12½	9	8½	17	76	81
36	37	36¾	50¼	48	45	6¼	¾	8½	10	18½	12½	9¾	9½	19	83	88
42	44¾	44½	56¼	54	51	6¼	¾	8½	10	19¼	12½	10½	10	23	93	100
48	48½	48¼	62¼	60	57	6¼	¾	8½	10	20	12½	11¼	10¾	25	99	107
54	56¼	56	68¼	66	63	6¼	¾	8½	10	21	12½	12½	11½	29	110	119
60	64	63¾	74¼	72	69	6¼	¾	8½	10	21¾	12½	12¾	12¾	33	120	130
72	75¾	75¾	86¼	84	81	6¼	¾	8½	10	22½	12½	13¾	13¼	39	137	149

Available in: Rubber Disk, Rubber Roll, Steel ¼" wall in 6" diameter, Rex Ribbed Covered Roll, Polyethylene Roll and Urethane, Ceramic or Rubber Coated Roll.
Part number example: 36 C6140V15 FS

REX IDLERS

Series B+, C and D

(5" Roll diameter only for B+)

POLYETHYLENE ROLL IDLERS Regreasable or Factory Sealed

A durable roll shell that resists corrosion and material build-up.

Longer Belt Life

Unlike steel, high density polyethylene rolls resist corrosion.

Consequently they deliver exceptional life in corrosive applications that quickly destroy conventional steel rolls. In the unlikely event of a stall, polyethylene rolls won't cut or damage conveyor belts.

Resists Corrosion

Using a proprietary formulation of high molecular weight polyethylene, Teflon® and carbon black, Rexnord's high density polyethylene rolls are manufactured using a patented extrusion process. The result is a roll that not only resists corrosion, but one that also resists material build-up. Clean rolls help extend belt life, and help eliminate training problems and conveyor vibration.

Less Chance of Belt Damage

Longer belt life is assured because polyethylene roll shell resists material build-up, and Rex designed "Mini-Gap" provides smallest possible space between rollers for better belt support and no-pinch belt protection.

Handles Surge Loading

Die formed, deep-pressed end brackets welded to inverted angle base assure rugged structural strength to prevent distortion.

Simple Belt Training Adjustment

of idlers is made fast and easy using slotted mounting holes. Precision jig welded frame assures positive, accurate alignment.

Less Material Build-Up

Truly self-cleaning inverted base angle — resists build-up of spillage — helps eliminate possible jamming of idler rolls.

Grease transfer tubes are totally encapsulated in steel.

Regreasable Idlers

Better Protection Against Abrasives and Moisture

Rex offers a special combination labyrinth with wiping seal and protective outer shield for your operating environment. This seal has five hard-to-get-through passages filled with grease to block contaminants from the roller bearings. The outer and inner seals are close tolerance injection molded nonmetallic. The labyrinth/shield seal is particularly excellent for long overland horizontal conveyors, because of its low friction torque or for applications where water is present or when frequent washdowns are required.

REX IDLERS

Series B+, C and D

(5" Roll diameter only for B+)

POLYETHYLENE ROLL IDLERS Regreasable or Factory Sealed

Other Features Include:

- A wide variety of available sizes — in 5 and 6-inch diameters and 18- to 72-inch widths.
- Galvanized frames with plated hardware for additional corrosion protection (optional).
- Polyethylene rolls are interchangeable with Rex steel rolls.

Typical Applications:

- Chemicals
- Acid
- Oil
- Pulp & paper
- Chemical compounds
- Coke
- Tar sands
- Wood Chips
- Salt
- Coal
- Phosphates
- Asphalt

Longer Idler Life — Series C

Rugged 3/4" tapered roller bearings and 3/4" diameter shafts provide ample load-carrying capacity.

Factory-Sealed Idlers

eliminate the need for relubrication ... solid shafts for more load carrying capacity.

See Page 46 for ordering information.

Refer to pages 22
thru 42 for
dimensional data.

Series D

1" diameter shafts.
(See Page 11)

Positive Roll Hold Down

Assures proper positioning and roll retention during shipment and installation, yet is easily removed for lift-out roll replacement.

Interchangeability

No need to cut base pads. Designed with slotted holes for easy adjustment — built to fit existing conveyor frame without cutting and fitting — conforms to CEMA standards.

Factory-Sealed Idlers

Better Protection Against Abrasives

Rex offers a special combination labyrinth with wiping seal and protective outer shield for your operating environment. This seal has five hard-to-get-through passages filled with grease to block contaminants from the roller bearings. The outer and inner seals are close tolerance injection molded nonmetallic. This product will provide excellent service in most environments and where minimum maintenance can be provided. Solid shafts are standard.

REX IDLERS

POLYETHYLENE ROLL IDLERS ORDERING INFORMATION — ORDER BY MODEL NUMBER

DESCRIPTION	MODEL NUMBER ◆	
	5" Roll (B+, C and D)	6" Roll (C and D)
Flat	X5027 FS	X6027 FS
Flat -Training - Actuating Shoe	X5035 FS	X6035 FS
Flat - Training- Positive Arm	X5036 FS	X6036 FS
Return	X5047 FS	X6047 FS
Return - Training - Positive Arm	X5059 FS	X6059 FS
Return - Training - Actuating Shoe	X5070 FS	X6070 FS
20° Troughing	X5206 FS	X6206 FS
20° Troughing - Training - Actuating Shoe	X5218 FS	X6218 FS
20° Troughing - Training - Positive Arm	X5264 FS	X6264 FS
35° Troughing	X5306 FS	X6306 FS
35° Troughing -Training - Actuating Shoe	X5318 FS	X6318 FS
35° Troughing- Training - Positive Arm	X5364 FS	X6364 FS
45° Troughing- Training - Positive Arm	X5406 FS	X6406 FS
45° Troughing- Training - Actuating Shoe	X5418 FS	X6418 FS
45°Troughing - Training - Positive Arm	X5464 FS	X6464 FS

If galvanized frame required; specify "galvanized frame"

Insert CEMA Classification for "X".

◆ FS is factory sealed; specify RG for regreasable.

SIDE GUIDE IDLERS

The use of side guide idlers is not normally recommended. There are some applications where conditions may require their use. On a new installation, side guide idlers are sometimes installed during the belt training period and then removed before the conveyor is placed in actual operation.

Side guide idlers tend to cause belt-edge wear. Training idlers are much preferred to assure proper belt alignment since they do not damage the belt.

Factory sealed ball bearings insure free roll rotation to keep belt edge wear to a minimum.

FOR TROUGHED BELTS

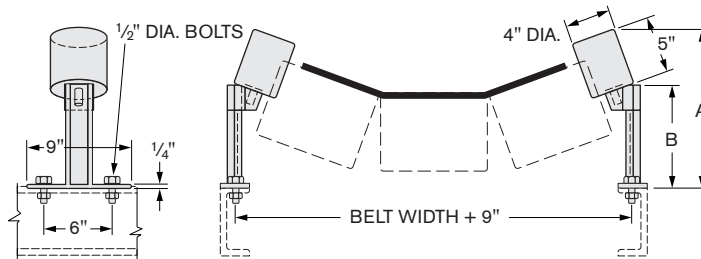

Dimensions in Inches — Average Weight in Pounds

Side Guide Part No.	20° Idlers			A	B	Idler Wgt. Lbs.	Side Guide Part No.	35° Idlers			A	B	Idler Wgt.
	Idler Series							Idler Series					
	B, B+	C, D						B, B+	C, D				
		5	6						5	6			
Belt Widths				Belt Widths									
611-20444	18-20	—	—	13 ¹ / ₈	7 ²⁵ / ₃₂	9.2	611-20445	18-20	—	—	15 ¹ / ₂	10 ⁷ / ₁₆	10.3
601-3327	24-36	18-20	18-20	14 ¹¹ / ₃₂	9 ⁹ / ₃₂	9.4	611-20446	24-30	18-20	17 ³ / ₃₂	12 ³ / ₃₂	10.6	
601-3328	42	24-36	24-30	15 ³ / ₄	10 ¹¹ / ₁₆	10.0	601-3333	36	24-30	18 ¹ / ₄	13 ⁷ / ₁₆	10.9	
601-3329	48	42-48	36-48	17 ¹⁵ / ₁₆	12 ⁷ / ₈	10.4	601-3334	42	36	20 ³ / ₃₂	15 ¹¹ / ₃₂	11.2	
601-3330	—	54-60	54-60	19 ¹¹ / ₁₆	14 ⁵ / ₈	10.8	601-3335	48	42-48	22 ³ / ₁₆	17 ³ / ₈	11.9	
							601-3336	—	54-60	24 ³ / ₄	19 ¹⁵ / ₁₆	13.1	

45° Side Guide Idlers also available upon request.

SIDE GUIDE IDLERS

FOR RETURN BELTS

Side Guide Part No.	Idler Series All Belt Sizes	Idler Wgt.
601-3518	B, B+ C, D	6.0

* For use with 1 1/2" drop brackets

Side Guide Part No.	Idler Series All Belt Sizes	Idler Wgt.
601-3519	C, D	10.0

* For use with 4 1/2" drop brackets

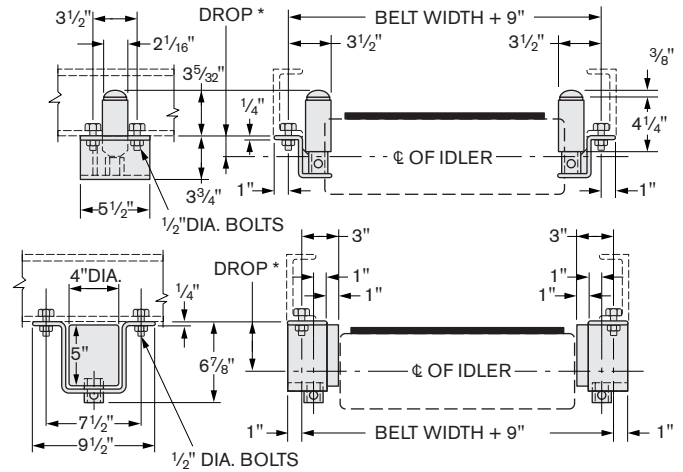

FOR FLEX WALL RETURN BELTS

Regreasable or factory sealed.

Side Guide Part No.	Diameter ①		Length	Over All Length	Wall Thickness	Weight
	Shaft	Roll				
611-21651	0.75	5	5.25	10	0.149	8
611-21963	0.75	4	5	10	0.149	6.7
611-22131	0.75	6	5.75	10	0.165	10
611-22132	0.75	6	5.75	10	0.25	11.1

① Thread is 16 UNF.

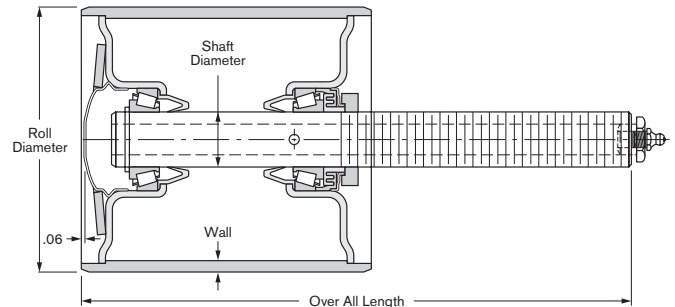

FOR FLAT BELTS

Side Guide Part No.	Idler Series All Belt Sizes	Idler Wgt.
601-3520	B C, D	17.0

* For use with 4 1/4" rise brackets

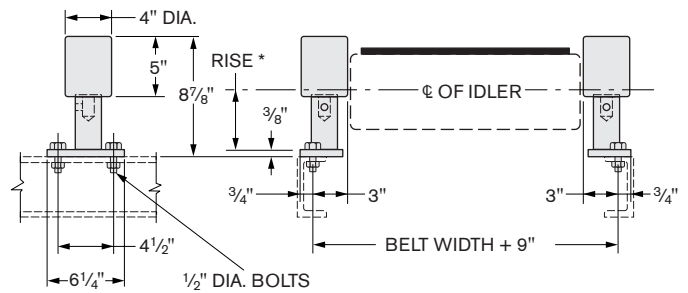

All items are normally available from stock

Note: Dimensions subject to change. Certified dimensions of ordered material furnished on request.

REX IDLERS

Series E — CEMA E 20°, 35° and 45° Trough — 6" and 7" Roll Diameter Regreasable or Factory Sealed

Increased Idler Capacity with Tapered Roller Bearings

Precision tapered roller bearings and 1¼" diameter shafts assure freer-turning rolls and less belt wear.

Maintenance Cost Reduced

Single point grease through lubrication with relief fitting and center tube minimizes maintenance cost.

Better Protection Against Abrasives and Moisture

Triple-labyrinth cartridge type grease seal protects bearings.

Roll Shaft Locks

Heavy end retainer provides locking of roll shaft.

Positive Through Greasing to all Bearing Cavities and Seals

Eliminates costly and troublesome exterior lubrication lines. Lowers maintenance cost and time.

Increased Bearing Life

Bearing life is increased by using a solid shaft to minimize deflection and resulting bearing misalignment

No-Pinch Belt Protection

Rex minimum gap provides smallest possible space between rolls.

Additional Bearing Protection

Machined steel adjusting nuts with deflector caps resist impact loads and provide additional bearing protection.

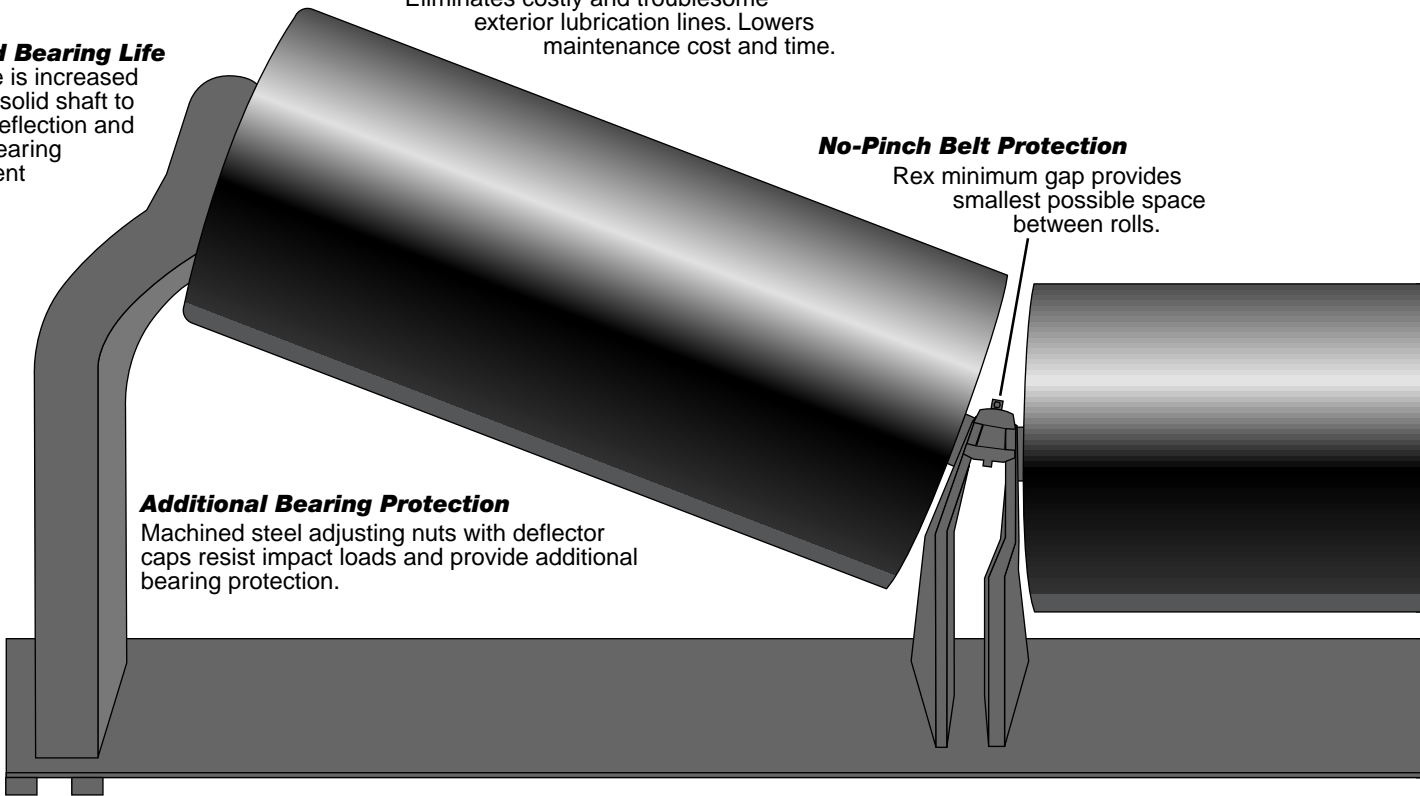

No Need to Cut or Fit Base Pads

Pads are designed to fit existing conveyor frames without recutting and fitting. Meet all CEMA standards.

Handles Surge Loading

Die-pressed, deep formed end brackets of rugged cross section give solid support and idler roll alignment.

REX IDLERS

Series E — CEMA E 20°, 35° and 45° Trough — 6" and 7" Roll Diameter Regreasable or Factory Sealed

Longer Roll Life

Superior sealing protection and true concentricity of rolls assure longer roll life under severest operating conditions.

Moisture Proof Assembly

Rigid construction and moisture-proof assembly result from continuously welded center tube joint.

No Lubrication Required

Factory lubricated and sealed idlers can be furnished as an optional feature, replacing the standard fittings with pipe plugs.

Ease of Assembly and Disassembly

Assures proper positioning of roll. Yet roll lift-out is simple and quick. Remove the hold down on center and end brackets and roll lifts out.

Reduced Downtime

Increased clearance between rolls and brackets minimizes material wedging between rolls and end brackets which cause roll stoppages.

Bearing Alignment Assured

Bearing seats are concentrically bored after welding to assure correct bearing alignment.

Moisture Proof

Moisture-proof assembly results from continuously welded shell, center tube and head.

Reduces Roll Damage

Inverted angle base prevents build-up of spillage ... eliminates possible jamming of idler rolls.

Ease of Maintenance

Jig welded frame assures positive, accurate roll alignment. Slotted mounting holes in base pad simplify adjustments.

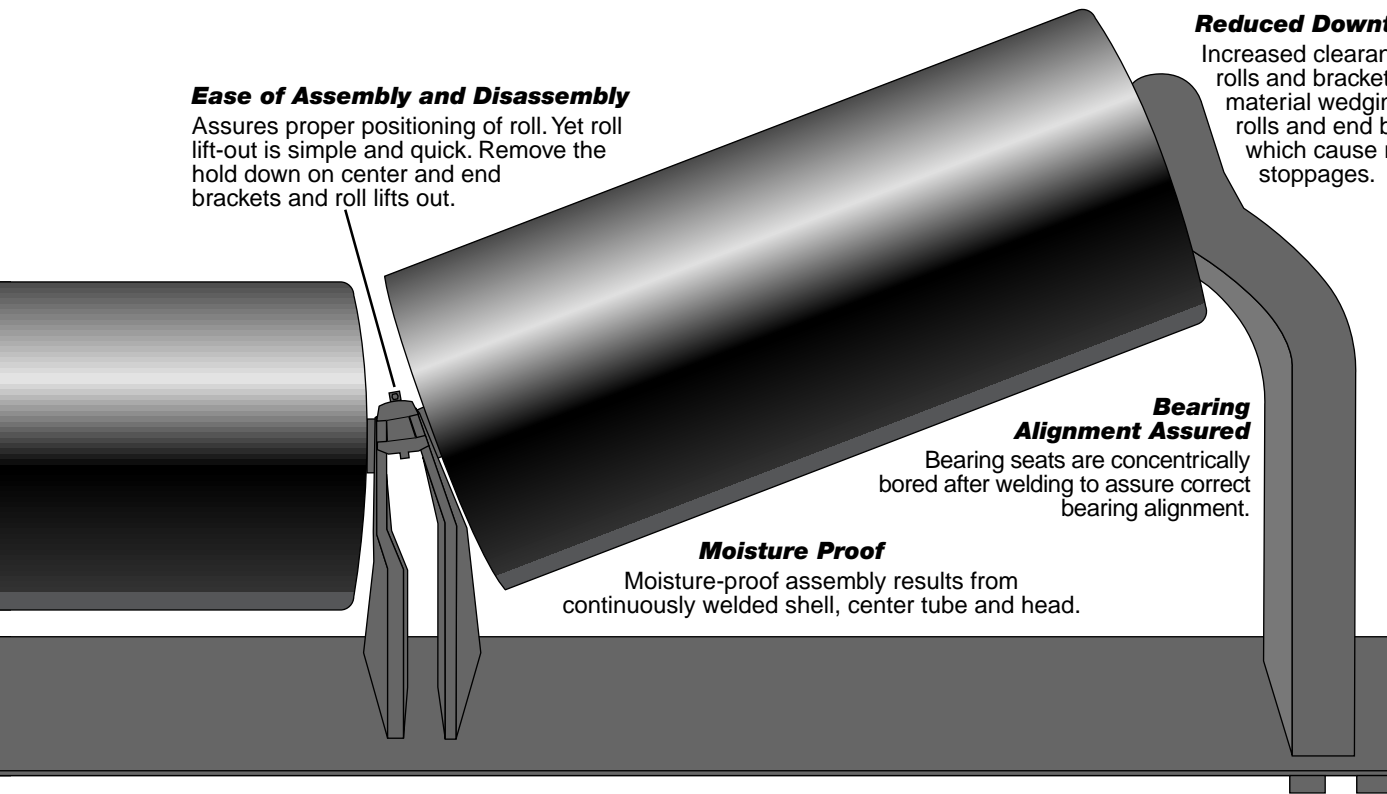

REX IDLERS

SERIES E

20° TROUGHING IDLER — EQUAL LENGTH ROLLS

REGREASABLE FACTORY SEALED

E6200 RG E6200 FS
6-Inch Steel Rolls

E7200 RG E7200 FS
7-Inch Steel Rolls

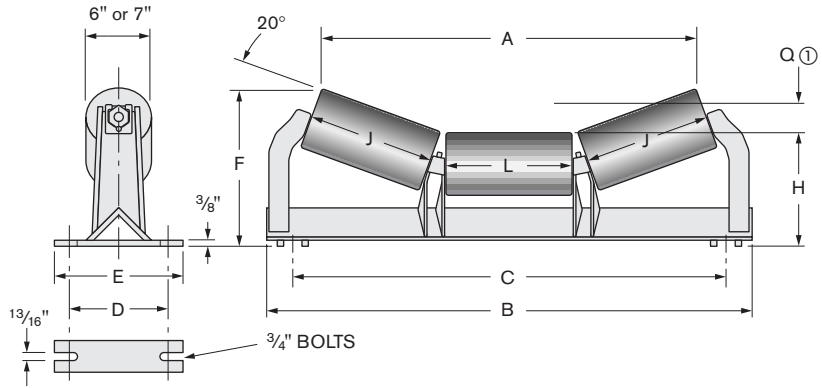

Dimensions in Inches — Average Weight in Pounds

Belt Width	A		B	C	D Min.	E	F		H		J	L	Q ^①	Idler Wgt.	
	6" Roll	7" Roll					6" Roll	7" Roll	6" Roll	7" Roll				6" Roll	7" Roll
36	41	40 ⁵ / ₈	50 ¹ / ₂	45	9	12	15 ³ / ₈	15 ³ / ₄	10 ¹ / ₂	11	13 ⁹ / ₁₆	13 ⁹ / ₁₆	1 ⁷ / ₈	140	168
42	46 ³ / ₄	46 ³ / ₈	56	51	9	12	16	16 ¹ / ₂	10 ¹ / ₂	11	15 ¹ / ₁₆	15 ¹ / ₁₆	2 ¹ / ₄	154	187
48	52 ¹ / ₂	52 ¹ / ₈	62	57	9	12	16 ³ / ₄	17 ¹ / ₈	10 ¹ / ₂	11	17 ⁹ / ₁₆	17 ⁹ / ₁₆	2 ¹ / ₂	167	203
54	58 ³ / ₈	58	68	63	9	12	17 ³ / ₈	17 ⁷ / ₈	10 ¹ / ₂	11	19 ⁹ / ₁₆	19 ⁹ / ₁₆	3	180	220
60	63 ¹ / ₂	63 ³ / ₈	74	69	9	12	18	18 ¹ / ₂	10 ¹ / ₂	11	21 ³ / ₈	21 ³ / ₈	3 ³ / ₄	192	236
72	74 ⁵ / ₈	74 ¹ / ₄	86	81	9	12	20 ¹ / ₈	20 ¹ / ₂	11 ¹ / ₄	11 ³ / ₄	25 ¹ / ₄	25 ¹ / ₄	3 ¹ / ₂	233	285
84	86 ¹ / ₈	85 ³ / ₄	98	93	11 ¹ / ₂	14 ¹ / ₂	22 ¹ / ₄	22 ⁵ / ₈	12	12 ¹ / ₂	29 ¹ / ₄	29 ¹ / ₄	4 ⁵ / ₈	304	363
96	97 ⁵ / ₈	97 ¹ / ₄	110	105	11 ¹ / ₂	14 ¹ / ₂	23 ³ / ₈	24	12	12 ¹ / ₂	33 ¹ / ₄	33 ¹ / ₄	5 ¹ / ₄	337	406

① Location of head pulley in relation to idler center roll.

20° TROUGHING IMPACT IDLER — EQUAL LENGTH ROLLS

REGREASABLE FACTORY SEALED

E6202 RG E6202 FS
6-Inch Rubber Rolls

E7202 RG E7202 FS
7-Inch Rubber Rolls

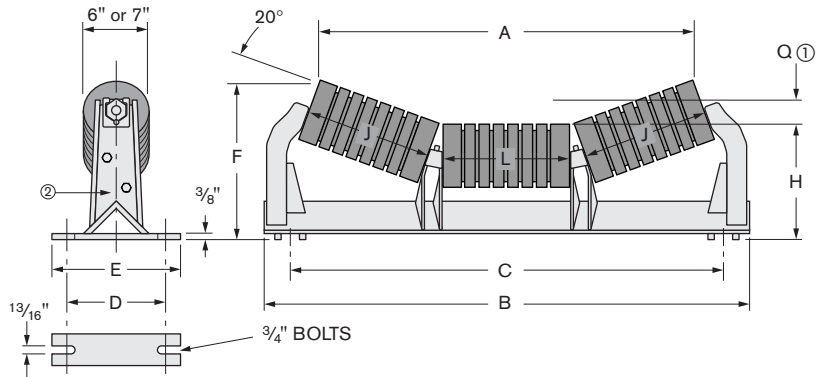

Dimensions in Inches — Average Weight in Pounds

Belt Width	A		B	C	D Min.	E	F		H		J	L	Q ^①	Idler Wgt.	
	6" Roll	7" Roll					6" Roll	7" Roll	6" Roll	7" Roll				6" Roll	7" Roll
36	40 ¹¹ / ₁₆	40 ³ / ₈	50 ¹ / ₂	45	9	12	15 ¹ / ₄	15 ¹¹ / ₁₆	10 ⁷ / ₁₆	10 ¹⁵ / ₁₆	13 ¹ / ₁₆	13 ¹ / ₁₆	1 ⁷ / ₈	145	161
42	46 ⁷ / ₁₆	46 ¹ / ₈	56	51	9	12	15 ¹⁵ / ₁₆	16 ³ / ₈	10 ⁷ / ₁₆	10 ¹⁵ / ₁₆	15 ¹ / ₁₆	15 ¹ / ₁₆	2 ¹ / ₄	165	183
48	52 ¹ / ₄	51 ⁷ / ₈	62	57	9	12	16 ³ / ₈	17 ¹ / ₁₆	10 ⁷ / ₁₆	10 ¹⁵ / ₁₆	17 ¹ / ₁₆	17 ¹ / ₁₆	2 ¹ / ₂	182	202
54	58 ¹ / ₈	57 ¹³ / ₁₆	68	63	9	12	17 ⁷ / ₁₆	17 ³ / ₄	10 ⁷ / ₁₆	10 ¹⁵ / ₁₆	19 ¹ / ₈	19 ¹ / ₈	3	199	222
60	63 ³ / ₁₆	62 ⁷ / ₈	74	69	9	12	17 ⁷ / ₈	18 ³ / ₈	10 ⁷ / ₁₆	10 ¹⁵ / ₁₆	20 ⁷ / ₈	20 ⁷ / ₈	3 ¹ / ₄	214	239
72	74 ³ / ₈	74	86	81	9	12	19 ¹⁵ / ₁₆	20 ⁷ / ₁₆	11 ³ / ₁₆	11 ¹¹ / ₁₆	24 ³ / ₄	24 ³ / ₄	3 ¹ / ₂	265	294
84	85 ⁷ / ₈	85 ¹ / ₁₆	98	93	11 ¹ / ₂	14 ¹ / ₂	22 ¹ / ₁₆	22 ¹ / ₂	11 ¹⁵ / ₁₆	12 ⁷ / ₁₆	28 ³ / ₄	28 ³ / ₄	4 ⁵ / ₈	364	397
96	97 ⁵ / ₈	97 ¹ / ₁₆	110	105	11 ¹ / ₂	14 ¹ / ₂	23 ⁷ / ₁₆	23 ³ / ₈	11 ¹⁵ / ₁₆	12 ⁷ / ₁₆	32 ³ / ₄	32 ³ / ₄	5 ¹ / ₄	407	444

① Location of head pulley in relation to idler center roll.

② Demountable end brackets.

Note: Dimensions subject to change. Certified dimensions of ordered material furnished on request.

REX IDLERS

SERIES E

20° TROUGHING TRAINING IDLER — EQUAL LENGTH ROLLS

Positive Arm Type — Belt Travel One Direction Only

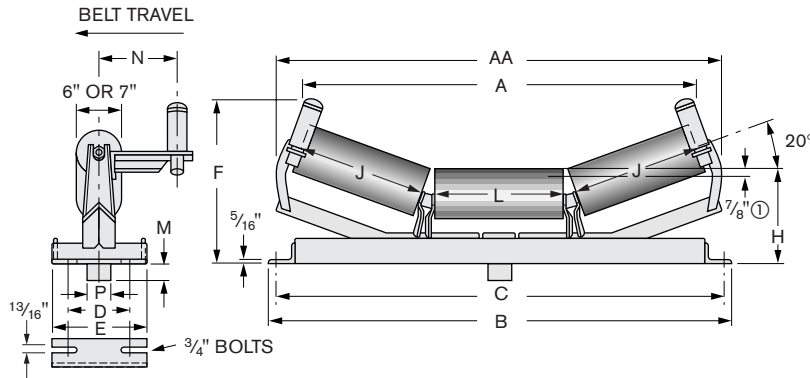

REGREASABLE FACTORY SEALED

E6212 RG E6212 FS
6-Inch Steel Rolls

E7212 RG E7212 FS
7-Inch Steel Rolls

Dimensions in Inches — Average Weight in Pounds

Belt Width	A	AA	B	C	D Min.	E	F	H		J	L	M	N	P	Idler Wgt.	
								6" Dia.	7" Dia.						6" Dia.	7" Dia.
36	42¾	51¾	47	45	9	12	18¾	11¾	11⅞	13⅞	13⅞	3⅞	10	3½	237	265
42	48½	57½	53	51	9	12	19⅞	11¾	11⅞	15⅞	15⅞	3⅞	10	3½	258	290
48	54¼	62¾	59	57	9	12	20⅞	11¾	11⅞	17⅞	17⅞	3⅞	10	3½	278	315
54	60¾	68¾	65	63	9	12	20¾	11¾	11⅞	19⅞	19⅞	3⅞	15	3½	300	339
60	65¼	74	71	69	9	12	21⅞	11¾	11⅞	21⅞	21⅞	3⅞	15	3½	318	362
72	76¾	85¾	83	81	9	12	23⅞	12½	12½	25¼	25¼	4¾	15	5¼	434	485

① Approximate distance to the top of the center roll of other idlers.

20° TROUGHING TRAINING IDLER — EQUAL LENGTH ROLLS

Actuating Shoe Type — Belt Travel Either Direction

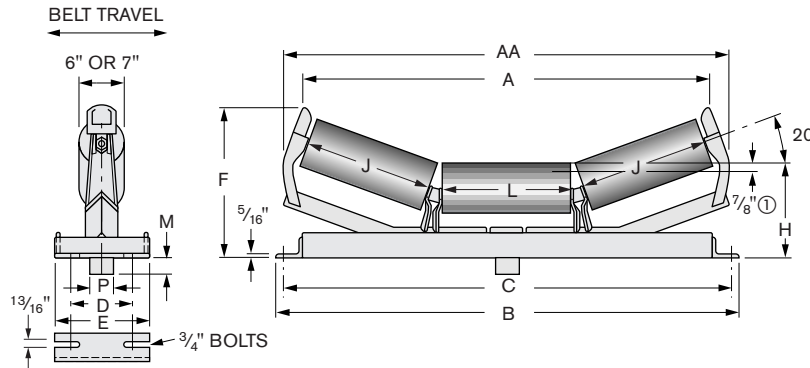

REGREASABLE FACTORY SEALED

E6210 RG E6210 FS
6-Inch Steel Rolls

E7210 RG E7210 FS
7-Inch Steel Rolls

Dimensions in Inches — Average Weight in Pounds

Belt Width	A	AA	B	C	D Min.	E	F	H		J	L	M	N	P	Idler Wgt.	
								6" Dia.	7" Dia.						6" Dia.	7" Dia.
36	44¾	44	51¾	47	45	9	12	17¾	11¾	11⅞	13⅞	3⅞	13⅞	3½	224	252
42	50½	49¾	57½	53	51	9	12	18¾	11¾	11⅞	15⅞	3⅞	15⅞	3½	245	277
48	55¾	55½	62¾	59	57	9	12	19⅞	11¾	11⅞	17⅞	3⅞	17⅞	3½	265	301
54	61¾	61¾	68¾	65	63	9	12	19¾	11¾	11⅞	19⅞	3⅞	19⅞	3½	286	326
60	66¾	66½	74	71	69	9	12	20¾	11¾	11⅞	21⅞	3⅞	21⅞	3½	305	348
72	78	77¾	85¾	83	81	9	12	22½	12½	12½	25¼	4¾	25¼	5¼	421	472

① Approximate distance to the top of the center roll of other idlers.

Note: Dimensions subject to change. Certified dimensions of ordered material furnished on request.

REX IDLERS

SERIES E

35° TROUGHING IDLER — EQUAL LENGTH ROLLS

REGREASABLE FACTORY SEALED

E6300 RG E6300 FS
6-Inch Steel Rolls

E7300 RG E7300 FS
7-Inch Steel Rolls

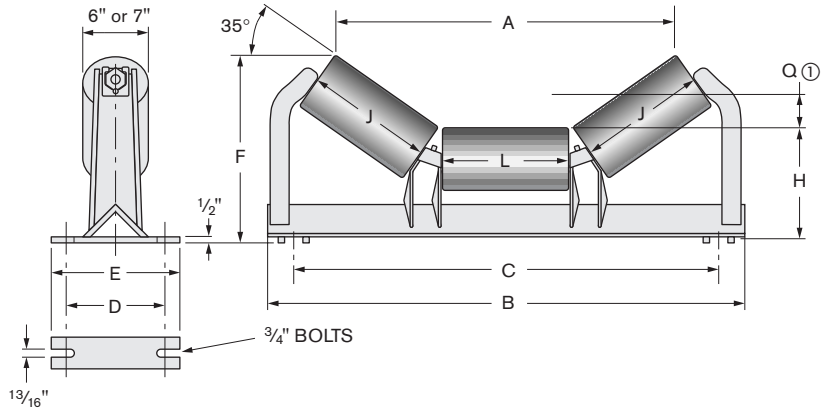

Dimensions in Inches — Average Weight in Pounds

Belt Width	A		B	C	D Min.	E	F		H		J	L	Q ^①	Idler Wgt.	
	6" Roll	7" Roll					6" Roll	7" Roll	6" Roll	7" Roll				6" Roll	7" Roll
36	37 ¹ / ₁₆	36 ⁷ / ₈	50 ¹ / ₂	45	9	12	18 ⁷ / ₁₆	19	10 ⁷ / ₁₆	11	13 ⁹ / ₁₆	13 ⁹ / ₁₆	3 ³ / ₈	149	175
42	42 ³ / ₈	42 ¹ / ₈	56	51	9	12	19 ⁹ / ₁₆	20 ¹ / ₈	10 ⁷ / ₁₆	11	15 ⁹ / ₁₆	15 ⁹ / ₁₆	3 ³ / ₄	168	193
48	47 ⁹ / ₈	47 ³ / ₈	61 ¹ / ₄	57	9	12	20 ³ / ₄	21 ¹ / ₄	10 ⁷ / ₁₆	11	17 ⁹ / ₁₆	17 ⁹ / ₁₆	4 ¹ / ₄	181	212
54	53 ¹ / ₁₆	52 ⁷ / ₈	67	63	9	12	21 ¹⁵ / ₁₆	22 ¹ / ₂	10 ⁷ / ₁₆	11	19 ⁹ / ₁₆	19 ⁹ / ₁₆	4 ⁷ / ₈	199	230
60	57 ³ / ₄	57 ¹ / ₂	71 ³ / ₄	69	9	12	22 ¹⁵ / ₁₆	23 ¹ / ₂	10 ⁷ / ₁₆	11	21 ³ / ₈	21 ³ / ₈	5 ¹ / ₂	213	246
72	67 ¹⁵ / ₁₆	67 ³ / ₄	83 ¹ / ₂	81	9	12	25 ¹³ / ₁₆	26 ³ / ₈	11 ¹ / ₈	11 ³ / ₄	25 ¹ / ₄	25 ¹ / ₄	6 ⁵ / ₈	260	296
84	78 ⁷ / ₁₆	78 ¹ / ₄	95 ¹ / ₂	93	11 ¹ / ₂	14 ¹ / ₂	28 ⁷ / ₈	29 ¹ / ₂	11 ⁷ / ₈	12 ¹ / ₂	29 ¹ / ₄	29 ¹ / ₄	7 ¹ / ₄	337	377
96	89	89 ³ / ₄	107 ¹ / ₂	105	11 ¹ / ₂	14 ¹ / ₂	31 ³ / ₁₆	31 ³ / ₄	11 ⁷ / ₈	12 ¹ / ₂	33 ¹ / ₄	33 ¹ / ₄	8 ⁷ / ₈	378	423

① Location of head pulley in relation to idler center roll.

35° TROUGHING IMPACT IDLER — EQUAL LENGTH ROLLS

REGREASABLE FACTORY SEALED

E6302 RG E6302 FS
6-Inch Rubber Rolls

E7302 RG E7302 FS
7-Inch Rubber Rolls

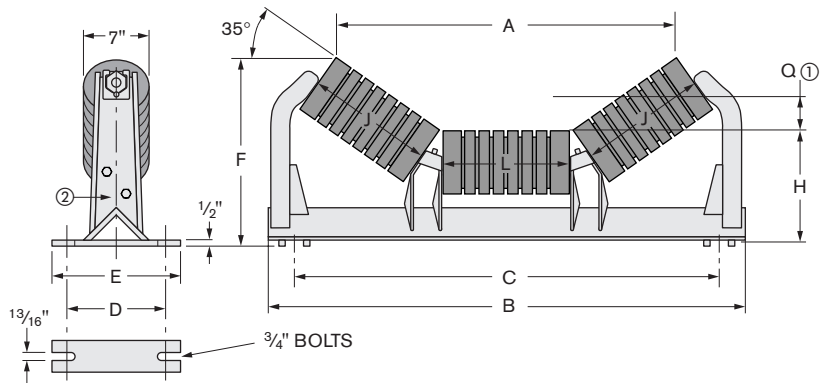

Dimensions in Inches — Average Weight in Pounds

Belt Width	A		B	C	D Min.	E	F		H		J	L	Q ^①	Idler Wgt.	
	6" Roll	7" Roll					6" Roll	7" Roll	6" Roll	7" Roll				6" Roll	7" Roll
36	37	36 ⁷ / ₁₆	50 ¹ / ₂	45	9	12	18 ⁷ / ₁₆	18 ¹³ / ₁₆	10 ⁷ / ₁₆	10 ¹⁵ / ₁₆	13 ¹ / ₁₆	13 ¹ / ₁₆	3 ³ / ₈	160	176
42	42 ⁵ / ₁₆	41 ¹¹ / ₁₆	56	51	9	12	19 ⁹ / ₁₆	20	10 ⁷ / ₁₆	10 ¹⁵ / ₁₆	15 ¹ / ₁₆	15 ¹ / ₁₆	3 ³ / ₄	181	199
48	47 ⁹ / ₁₆	47	61 ¹ / ₄	57	9	12	20 ³ / ₄	21 ¹ / ₈	10 ⁷ / ₁₆	10 ¹⁵ / ₁₆	17 ¹ / ₁₆	17 ¹ / ₁₆	4 ¹ / ₄	199	219
54	53	52 ⁷ / ₁₆	67	63	9	12	21 ⁷ / ₈	22 ⁹ / ₁₆	10 ⁷ / ₁₆	10 ¹⁵ / ₁₆	19 ¹ / ₈	19 ¹ / ₈	4 ⁷ / ₈	217	240
60	57 ⁹ / ₈	57 ¹ / ₁₆	71 ³ / ₄	69	9	12	22 ⁷ / ₈	23 ³ / ₁₆	10 ⁷ / ₁₆	10 ¹⁵ / ₁₆	20 ⁷ / ₈	20 ⁷ / ₈	5 ¹ / ₂	233	258
72	67 ⁷ / ₈	67 ⁹ / ₁₆	83 ¹ / ₂	81	9	12	25 ¹³ / ₁₆	26 ¹ / ₄	11 ³ / ₈	11 ¹¹ / ₁₆	24 ³ / ₄	24 ³ / ₄	6 ⁵ / ₈	285	314
84	78 ⁷ / ₁₆	77 ¹³ / ₁₆	95 ¹ / ₂	93	11 ¹ / ₂	14 ¹ / ₂	28 ⁷ / ₈	29 ⁹ / ₁₆	11 ¹⁵ / ₁₆	12 ⁷ / ₁₆	28 ³ / ₄	28 ³ / ₄	7 ¹ / ₄	376	409
96	88 ¹³ / ₁₆	88 ³ / ₈	107 ¹ / ₂	105	11 ¹ / ₂	14 ¹ / ₂	31 ³ / ₁₆	31 ⁹ / ₁₆	11 ¹⁵ / ₁₆	12 ⁷ / ₁₆	32 ³ / ₄	32 ³ / ₄	8 ⁷ / ₈	421	458

① Location of head pulley in relation to idler center roll.

② Demountable end brackets.

Note: Dimensions subject to change. Certified dimensions of ordered material furnished on request.

REX IDLERS

SERIES E

35° TROUGHING TRAINING IDLER — EQUAL LENGTH ROLLS

Positive Arm Type — Belt Travel One Direction Only

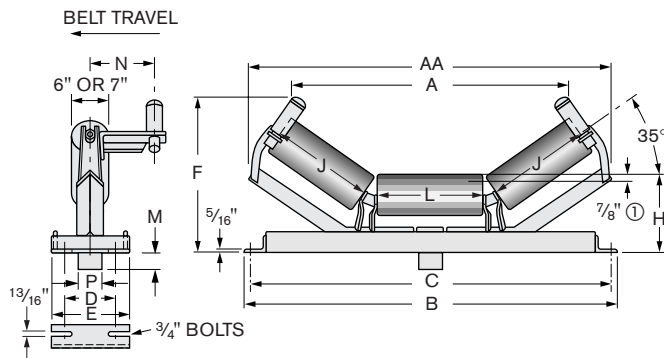

REGREASABLE	FACTORY SEALED
E6312 RG	E6312 FS
	6-Inch Steel Rolls
E7312 RG	E7312 FS
	7-Inch Steel Rolls

Dimensions in Inches — Average Weight in Pounds

Belt Width	A	AA	B	C	D Min.	E	F	H		J	L	M	N	P	Idler Wgt.	
								6" Dia.	7" Dia.						6" Dia.	7" Dia.
36	38 ¹ / ₈	53 ³ / ₈	47	45	9	12	22 ³ / ₈	11 ³ / ₈	11 ⁷ / ₈	13 ⁹ / ₁₆	13 ⁹ / ₁₆	3 ¹ / ₁₆	10	3 ¹ / ₂	242	270
42	43 ¹ / ₂	58 ³ / ₈	53	51	9	12	23 ¹ / ₂	11 ³ / ₈	11 ⁷ / ₈	15 ⁹ / ₁₆	15 ⁹ / ₁₆	3 ¹ / ₁₆	10	3 ¹ / ₂	263	295
48	48 ³ / ₄	63 ³ / ₈	59	57	9	12	24 ⁵ / ₈	11 ³ / ₈	11 ⁷ / ₈	17 ⁹ / ₁₆	17 ⁹ / ₁₆	3 ¹ / ₁₆	10	3 ¹ / ₂	283	320
54	54 ¹ / ₈	69 ¹ / ₄	65	63	9	12	25 ³ / ₄	11 ³ / ₈	11 ⁷ / ₈	19 ⁹ / ₁₆	19 ⁹ / ₁₆	3 ¹ / ₁₆	15	3 ¹ / ₂	304	344
60	58 ³ / ₄	73 ⁷ / ₈	71	69	9	12	26 ³ / ₄	11 ³ / ₈	11 ⁷ / ₈	21 ³ / ₈	21 ³ / ₈	3 ¹ / ₁₆	15	3 ¹ / ₂	319	362
72	69	85 ⁷ / ₈	83	81	9	12	29 ³ / ₄	12 ¹ / ₈	12 ³ / ₈	25 ¹ / ₄	25 ¹ / ₄	4 ³ / ₄	15	5 ¹ / ₄	434	486

① Location of head pulley in relation to idler center roll.

35° TROUGHING TRAINING IDLER — EQUAL LENGTH ROLLS

Actuating Shoe Type — Belt Travel Either Direction

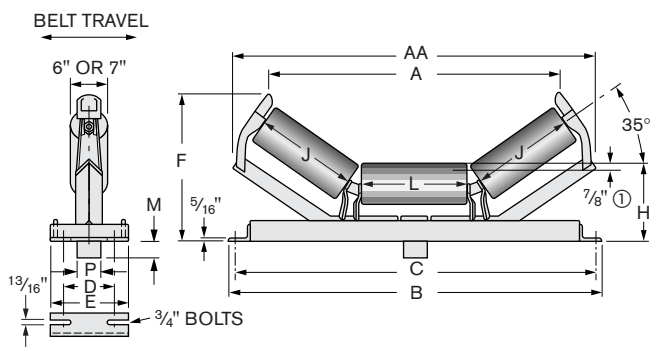

REGREASABLE	FACTORY SEALED
E6310 RG	E6310 FS
	6-Inch Steel Rolls
E7310 RG	E7310 FS
	7-Inch Steel Rolls

Dimensions in Inches — Average Weight in Pounds

Belt Width	A		AA	B	C	D Min.	E	F		H ^①		J	L	M	P	Idler Wgt.	
	6" Dia.	7" Dia.						6" Dia.	7" Dia.	6" Dia.	7" Dia.					6" Dia.	7" Dia.
36	39 ⁷ / ₈	39 ³ / ₈	53 ³ / ₈	47	45	9	12	21 ⁵ / ₁₆	21 ¹ / ₁₆	11 ³ / ₈	11 ⁷ / ₈	13 ⁹ / ₁₆	13 ⁹ / ₁₆	3 ¹ / ₁₆	3 ¹ / ₂	229	257
42	45 ¹ / ₄	44 ³ / ₈	58 ³ / ₈	53	51	9	12	22 ⁵ / ₁₆	22 ³ / ₁₆	11 ³ / ₈	11 ⁷ / ₈	15 ⁹ / ₁₆	15 ⁹ / ₁₆	3 ¹ / ₁₆	3 ¹ / ₂	250	282
48	50 ¹ / ₂	49 ⁷ / ₈	63 ³ / ₈	59	57	9	12	23 ⁹ / ₁₆	23 ⁵ / ₁₆	11 ³ / ₈	11 ⁷ / ₈	17 ⁹ / ₁₆	17 ⁹ / ₁₆	3 ¹ / ₁₆	3 ¹ / ₂	270	306
54	55 ⁷ / ₈	55 ³ / ₈	69 ¹ / ₄	65	63	9	12	24 ¹ / ₁₆	25 ³ / ₁₆	11 ³ / ₈	11 ⁷ / ₈	19 ⁹ / ₁₆	19 ⁹ / ₁₆	3 ¹ / ₁₆	3 ¹ / ₂	291	331
60	60 ¹ / ₂	60	73 ⁷ / ₈	71	69	9	12	25 ¹ / ₁₆	26 ³ / ₁₆	11 ³ / ₈	11 ⁷ / ₈	21 ³ / ₈	21 ³ / ₈	3 ¹ / ₁₆	3 ¹ / ₂	306	349
72	70 ³ / ₄	70 ¹ / ₄	85 ⁷ / ₈	83	81	9	12	28 ¹ / ₁₆	29 ¹ / ₁₆	12 ³ / ₈	12 ³ / ₈	25 ¹ / ₄	25 ¹ / ₄	4 ³ / ₄	5 ¹ / ₄	421	473

① Location of head pulley in relation to idler center roll.

Note: Dimensions subject to change. Certified dimensions of ordered material furnished on request.

REX IDLERS

SERIES E 45° TROUGHING IDLER — EQUAL LENGTH ROLLS

REGREASABLE FACTORY SEALED

E6400 RG E6400 FS
6-Inch Steel Rolls

E7400 RG E7400 FS
7-Inch Steel Rolls

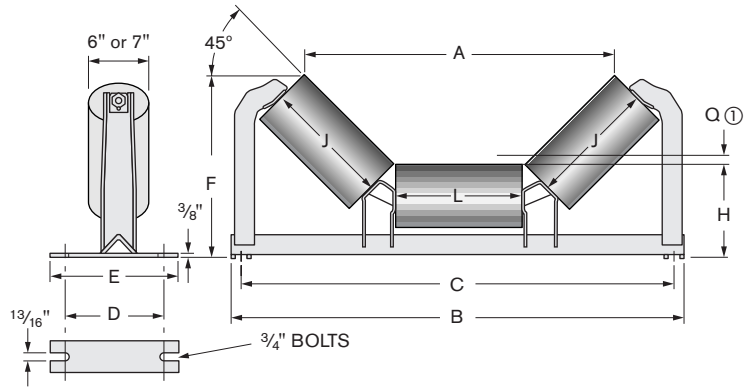

Dimensions in Inches — Average Weight in Pounds

Belt Width	A		B	C	D Min.	E	F		H		J	L	Q ^①	Idler Wgt.	
	6" Roll	7" Roll					6" Roll	7" Roll	6" Roll	7" Roll				6" Roll	7" Roll
	36	33 ⁷ / ₈					33 ¹ / ₄	54	45	9				12	20 ³ / ₈
42	38 ³ / ₄	38	59 ¹ / ₂	51	9	12	21 ¹³ / ₁₆	22 ³ / ₁₆	10 ¹ / ₂	11	15 ¹ / ₁₆	15 ¹ / ₁₆	4 ⁵ / ₈	167	198
48	43 ⁵ / ₈	42 ⁷ / ₈	65 ¹ / ₂	57	9	12	23 ³ / ₁₆	23 ³ / ₁₆	10 ¹ / ₂	11	17 ⁹ / ₁₆	17 ⁹ / ₁₆	5 ³ / ₈	180	217
54	48 ¹ / ₂	47 ⁷ / ₈	71 ¹ / ₂	63	9	12	24 ¹¹ / ₁₆	25	10 ¹ / ₂	11	19 ⁹ / ₁₆	19 ⁹ / ₁₆	6 ¹ / ₈	196	236
60	52 ³ / ₄	52 ¹ / ₂	74	69	9	12	25 ⁷ / ₈	26 ¹ / ₄	10 ¹ / ₂	11	21 ¹ / ₈	21 ¹ / ₈	6 ³ / ₄	209	253
72	62 ¹ / ₈	61 ¹ / ₂	87	81	9	12	29 ³ / ₄	29 ³ / ₄	11 ¹ / ₄	11 ³ / ₄	25 ¹ / ₄	25 ¹ / ₄	7 ⁷ / ₈	253	304

① Location of head pulley in relation to idler center roll.

45° TROUGHING IMPACT IDLER — EQUAL LENGTH ROLLS

REGREASABLE FACTORY SEALED

E6402 RG E6402 FS
6-Inch Rubber Rolls

E7402 RG E7402 FS
7-Inch Rubber Rolls

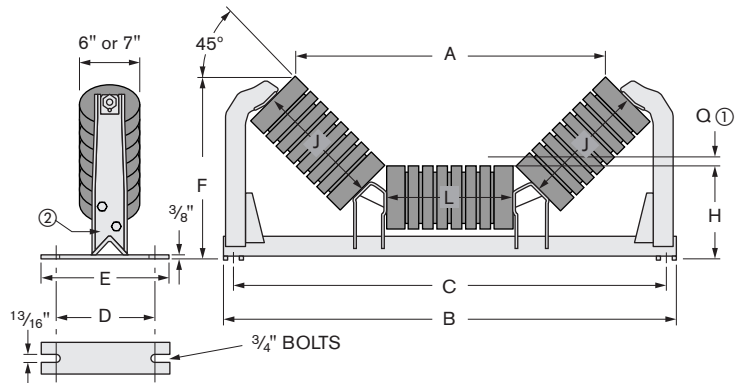

Dimensions in Inches — Average Weight in Pounds

Belt Width	A		B	C	D Min.	E	F		H		J	L	Q ^①	Idler Wgt.	
	6" Roll	7" Roll					6" Roll	7" Roll	6" Roll	7" Roll				6" Roll	7" Roll
	36	33 ⁷ / ₈					33 ¹ / ₈	54	45	9				12	20 ¹ / ₄
42	38 ¹¹ / ₁₆	37 ¹⁵ / ₁₆	59 ¹ / ₂	51	9	12	21 ¹¹ / ₁₆	22 ¹ / ₁₆	10 ⁷ / ₁₆	10 ¹⁵ / ₁₆	15 ¹ / ₁₆	15 ¹ / ₁₆	4 ⁵ / ₈	185	204
48	43 ¹ / ₂	42 ¹³ / ₁₆	65 ¹ / ₂	57	9	12	23 ³ / ₁₆	23 ³ / ₁₆	10 ⁷ / ₁₆	10 ¹⁵ / ₁₆	17 ¹ / ₁₆	17 ¹ / ₁₆	5 ³ / ₈	204	224
54	48 ¹ / ₂	47 ³ / ₄	71 ¹ / ₂	63	9	12	24 ⁹ / ₁₆	24 ⁷ / ₈	10 ⁷ / ₁₆	10 ¹⁵ / ₁₆	19 ¹ / ₈	19 ¹ / ₈	6 ¹ / ₈	223	246
60	52 ¹¹ / ₁₆	52	74	69	9	12	25 ¹³ / ₁₆	26 ¹ / ₈	10 ⁷ / ₁₆	10 ¹⁵ / ₁₆	21 ¹ / ₈	21 ¹ / ₈	6 ³ / ₄	240	265
72	62 ¹ / ₈	61 ³ / ₈	87	81	9	12	29 ¹ / ₄	29 ⁵ / ₁₆	11 ¹ / ₁₆	11 ¹¹ / ₁₆	24 ³ / ₄	24 ³ / ₄	7 ⁷ / ₈	293	322

① Location of head pulley in relation to idler center roll.

② Demountable end brackets.

Note: Dimensions subject to change. Certified dimensions of ordered material furnished on request.

REX IDLERS

SERIES E

20° TROUGHING TRAINING IDLER — UNEQUAL LENGTH ROLLS

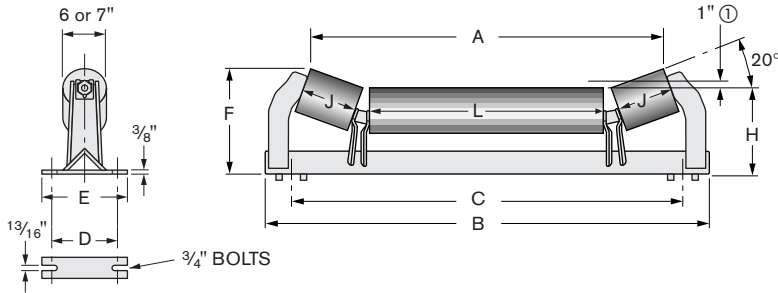

REGREASABLE FACTORY SEALED

E6201 RG E6201 FS
6-Inch Steel Rolls

E7201 RG E7201 FS
7-Inch Steel Rolls

Dimensions in Inches — Average Weight in Pounds

Belt Width	A		B	C	D Min.	E	F		H		J	L	Idler Wgt.	
	6" Dia.	7" Dia.					6" Dia.	7" Dia.	6" Dia.	7" Dia.			6" Dia.	7" Dia.
36	41	40 ³ / ₄	50 ¹ / ₂	45	9	12	13 ¹ / ₈	13 ³ / ₁₆	10 ⁷ / ₁₆	10 ¹⁵ / ₁₆	7 ³ / ₈	25 ¹ / ₄	138	167
42	46 ⁷ / ₈	46 ⁵ / ₈	56	51	9	12	13 ¹ / ₈	13 ³ / ₁₆	10 ⁷ / ₁₆	10 ¹⁵ / ₁₆	7 ³ / ₈	31 ¹ / ₈	146	179
48	52 ⁷ / ₈	52 ⁵ / ₈	62	57	9	12	13 ¹ / ₈	13 ³ / ₁₆	10 ⁷ / ₁₆	10 ¹⁵ / ₁₆	7 ³ / ₈	37 ¹ / ₈	158	195
54	58 ⁷ / ₈	58 ⁵ / ₈	68	63	9	12	13 ¹ / ₈	13 ³ / ₁₆	10 ⁷ / ₁₆	10 ¹⁵ / ₁₆	7 ³ / ₈	43 ¹ / ₈	177	218
60	64 ⁷ / ₈	64 ⁵ / ₈	74	69	9	12	13 ¹ / ₈	13 ³ / ₁₆	10 ⁷ / ₁₆	10 ¹⁵ / ₁₆	7 ³ / ₈	49 ¹ / ₈	190	233
72	76 ⁷ / ₈	76 ⁵ / ₈	86	81	9	12	13 ¹ / ₈	14 ³ / ₈	11 ¹ / ₈	11 ¹ / ₈	7 ³ / ₈	61 ¹ / ₈	229	280

① Location of head pulley in relation to idler center roll.

20° TROUGHING TRAINING IDLER — UNEQUAL LENGTH ROLLS

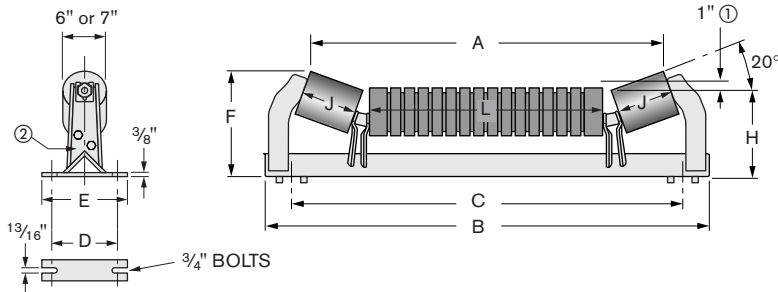

REGREASABLE FACTORY SEALED

E6203 RG E6203 FS
6-Inch Steel & Rubber Rolls

E7203 RG E7203 FS
7-Inch Steel & Rubber Rolls

Dimensions in Inches — Average Weight in Pounds

Belt Width	A		B	C	D Min.	E	F		H		J	L	Idler Wgt.	
	6" Dia.	7" Dia.					6" Dia.	7" Dia.	6" Dia.	7" Dia.			6" Dia.	7" Dia.
36	40 ¹³ / ₁₆	40 ¹ / ₂	50 ¹ / ₂	45	9	12	13 ¹ / ₈	13 ³ / ₁₆	10 ⁷ / ₁₆	10 ¹⁵ / ₁₆	7 ³ / ₈	24 ³ / ₄	137	158
42	46 ¹¹ / ₁₆	46 ³ / ₈	56	51	9	12	13 ¹ / ₈	13 ³ / ₁₆	10 ⁷ / ₁₆	10 ¹⁵ / ₁₆	7 ³ / ₈	30 ⁵ / ₈	153	176
48	52 ¹¹ / ₁₆	52 ³ / ₈	62	57	9	12	13 ¹ / ₈	13 ³ / ₁₆	10 ⁷ / ₁₆	10 ¹⁵ / ₁₆	7 ³ / ₈	36 ³ / ₈	169	194
54	58 ¹¹ / ₁₆	58 ³ / ₈	68	63	9	12	13 ¹ / ₈	13 ³ / ₁₆	10 ⁷ / ₁₆	10 ¹⁵ / ₁₆	7 ³ / ₈	42 ³ / ₈	185	213
60	64 ¹¹ / ₁₆	64 ³ / ₈	74	69	9	12	13 ¹ / ₈	13 ³ / ₁₆	10 ⁷ / ₁₆	10 ¹⁵ / ₁₆	7 ³ / ₈	48 ⁵ / ₈	201	231
72	76 ¹¹ / ₁₆	76 ³ / ₈	86	81	9	12	13 ¹ / ₈	14 ³ / ₈	11 ¹ / ₈	11 ¹ / ₈	7 ³ / ₈	60 ³ / ₈	250	285

① Location of head pulley in relation to idler center roll.

② Demountable end bracket.

Note: Dimensions subject to change. Certified dimensions of ordered material furnished on request.

REX IDLERS

SERIES E RETURN IDLER

REGREASABLE FACTORY SEALED
E6040 RG **E6040 FS**
6-Inch Steel Roll
E7040 RG **E7040 FS**
7-Inch Steel Roll

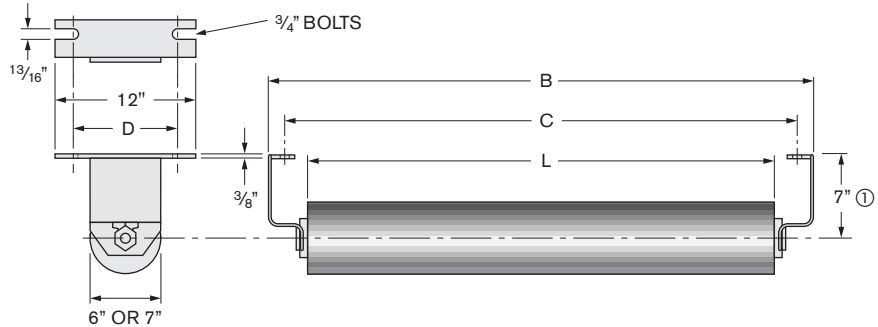

Dimensions in Inches — Average Weight in Pounds

Belt Width	B	C	D Minimum	L	Idler Weight	
					6" Roll	7" Roll
36	48 $\frac{1}{4}$	45	9	39 $\frac{7}{8}$	82	109
42	54 $\frac{1}{4}$	51	9	45 $\frac{7}{8}$	90	121
48	60 $\frac{1}{4}$	57	9	51 $\frac{7}{8}$	99	133
54	66 $\frac{1}{4}$	63	9	57 $\frac{7}{8}$	107	145
60	72 $\frac{1}{4}$	69	9	63 $\frac{7}{8}$	115	156
72	84 $\frac{1}{4}$	81	9	75 $\frac{7}{8}$	131	181

① Also available with 4 $\frac{1}{2}$ " drop.

DISC RETURN IDLER

Belt Travel Either Direction

Available with rubber or urethane discs.

REGREASABLE FACTORY SEALED
E6043 RG **E6043 FS**
6-Inch Rubber Disc Roll
E7043 RG **E7043 FS**
7-Inch Rubber Disc Roll

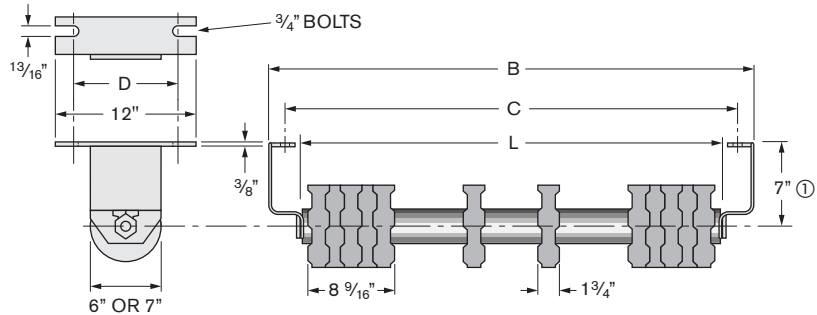

Five discs on each end is standard.

Dimensions in Inches — Average Weight in Pounds

Belt Width	B	C	D Minimum	L	Idler Weight		Number of Discs
					6" Roll	7" Roll	
36	48 $\frac{1}{4}$	45	9	39 $\frac{11}{16}$	88	92	13
42	54 $\frac{1}{4}$	51	9	45 $\frac{11}{16}$	96	100	14
48	60 $\frac{1}{4}$	57	9	51 $\frac{11}{16}$	104	108	15
54	66 $\frac{1}{4}$	63	9	57 $\frac{11}{16}$	112	118	16
60	72 $\frac{1}{4}$	69	9	63 $\frac{11}{16}$	121	127	17
72	84 $\frac{1}{4}$	81	9	75 $\frac{11}{16}$	137	143	19

① Also available with 4 $\frac{1}{2}$ " drop.

Note: Dimensions subject to change. Certified dimensions of ordered material furnished on request.

REX IDLERS

SERIES E FLAT STEEL IDLER

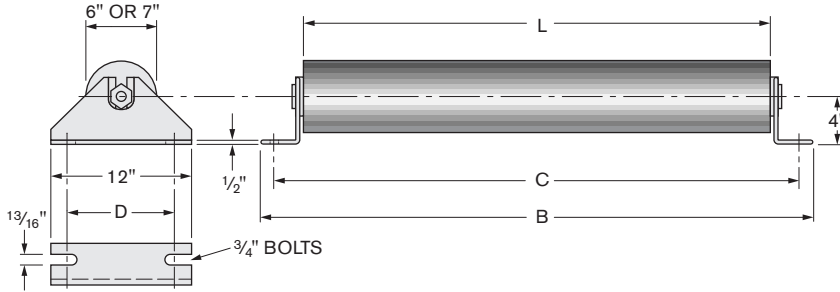

REGREASABLE	FACTORY SEALED
E6020 RG	E6020 FS
	<i>6-Inch Steel Roll</i>
E7020 RG	E7020 FS
	<i>7-Inch Steel Roll</i>

Dimensions in Inches — Average Weight in Pounds

Belt Width	B	C	D Minimum	L	Idler Weight	
					6" Roll	7" Roll
36	47 ⁷ / ₁₆	45	9	39 ⁷ / ₈	81	108
42	53 ⁷ / ₁₆	51	9	45 ⁷ / ₈	89	120
48	59 ⁷ / ₁₆	57	9	51 ⁷ / ₈	98	132
54	65 ⁷ / ₁₆	63	9	57 ⁷ / ₈	106	144
60	71 ⁷ / ₁₆	69	9	63 ⁷ / ₈	114	155
72	83 ⁷ / ₁₆	81	9	75 ⁷ / ₈	130	180

FLAT RUBBER IDLER

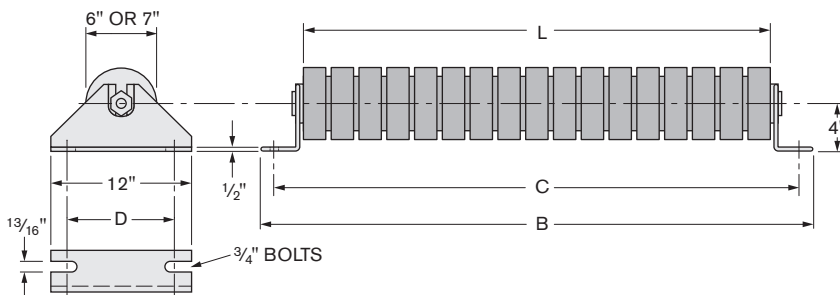

REGREASABLE	FACTORY SEALED
E6025 RG	E6025 FS
	<i>6-Inch Rubber Roll</i>
E7025 RG	E7025 FS
	<i>7-Inch Rubber Roll</i>

Dimensions in Inches — Average Weight in Pounds

Belt Width	B	C	D Minimum	L	Idler Weight	
					6" Roll	7" Roll
36	47 ⁷ / ₁₆	45	9	38	126	139
42	53 ⁷ / ₁₆	51	9	44 ⁷ / ₈	140	156
48	59 ⁷ / ₁₆	57	9	50 ⁷ / ₈	155	173
54	65 ⁷ / ₁₆	63	9	56 ⁷ / ₈	170	190
60	71 ⁷ / ₁₆	69	9	62 ⁷ / ₈	185	207
72	83 ⁷ / ₁₆	81	9	74 ⁷ / ₈	214	241

Note: Dimensions subject to change. Certified dimensions of ordered material furnished on request.

REX IDLERS

SERIES E

RETURN TRAINING IDLER

Positive Arm Type - Belt Travel One Direction Only

REGREASABLE FACTORY SEALED

E6052 RG E6052 FS
6-Inch Steel Roll

E7052 RG E7052 FS
7-Inch Steel Roll

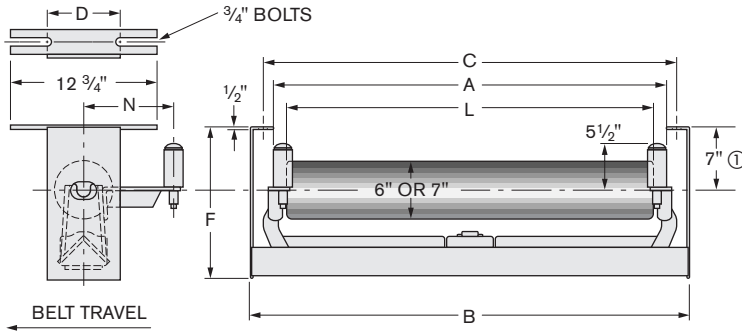

Dimensions in Inches — Average Weight in Pounds

Belt Width	A	B	C	D Minimum	F	L	N	Idler Weight	
								6" Roll	7" Roll
36	44 ³ / ₈	48 ¹ / ₂	45	9	18 ⁹ / ₁₆	39 ⁷ / ₈	10	254	281
42	50 ³ / ₈	54 ¹ / ₂	51	9	18 ⁹ / ₁₆	45 ⁷ / ₈	10	310	341
48	56 ³ / ₈	60 ¹ / ₂	57	9	18 ⁹ / ₁₆	51 ⁷ / ₈	10	331	366
54	62 ³ / ₈	66 ¹ / ₂	63	9	18 ⁹ / ₁₆	57 ⁷ / ₈	15	348	386
60	68 ³ / ₈	72 ¹ / ₂	69	9	18 ⁹ / ₁₆	63 ⁷ / ₈	15	374	414
72	80 ³ / ₈	84 ¹ / ₂	81	9	19 ¹ / ₁₆	75 ⁷ / ₈	15	520	570

① 1 3/4" or 4 1/4" can be furnished for wide base idlers.

DISC RETURN TRAINING IDLER

Positive Arm Type — Belt Travel One Direction Only

REGREASABLE FACTORY SEALED

E6056 RG E6056 FS
6-Inch Rubber Disc Roll

E7056 RG E7056 FS
7-Inch Rubber Disc Roll

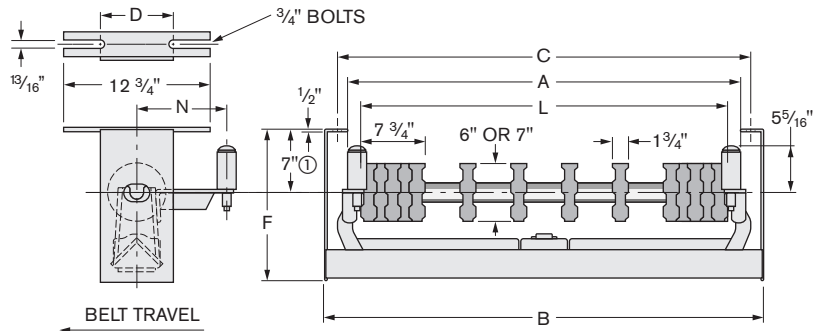

Five discs on each end is standard.

Dimensions in Inches — Average Weight in Pounds

Belt Width	A	B	C	D Minimum	F	L	N	Number of Discs	Idler Weight	
									6" Roll	7" Roll
36	44 ³ / ₈	48 ¹ / ₂	45	9	18 ⁹ / ₁₆	39 ¹ / ₁₆	10	13	260	264
42	50 ³ / ₈	54 ¹ / ₂	51	9	18 ⁹ / ₁₆	45 ¹ / ₁₆	10	14	316	320
48	56 ³ / ₈	60 ¹ / ₂	57	9	18 ⁹ / ₁₆	51 ¹ / ₁₆	10	15	337	341
54	62 ³ / ₈	66 ¹ / ₂	63	9	18 ⁹ / ₁₆	57 ¹ / ₁₆	15	16	353	359
60	68 ³ / ₈	72 ¹ / ₂	69	9	18 ⁹ / ₁₆	63 ¹ / ₁₆	15	17	379	385
72	80 ³ / ₈	84 ¹ / ₂	81	9	19 ¹ / ₁₆	75 ¹ / ₁₆	15	19	525	531

① 1 3/4" or 4 1/4" can be furnished for wide base idlers.

Note: Dimensions subject to change. Certified dimensions of ordered material furnished on request.

REX IDLERS

SERIES E FLAT TRAINING IDLER

Positive Arm Type - Belt Travel One Direction Only

REGREASABLE FACTORY SEALED

E6031 RG E6031 FS
6-Inch Steel Roll

E7031 RG E7031 FS
7-Inch Steel Roll

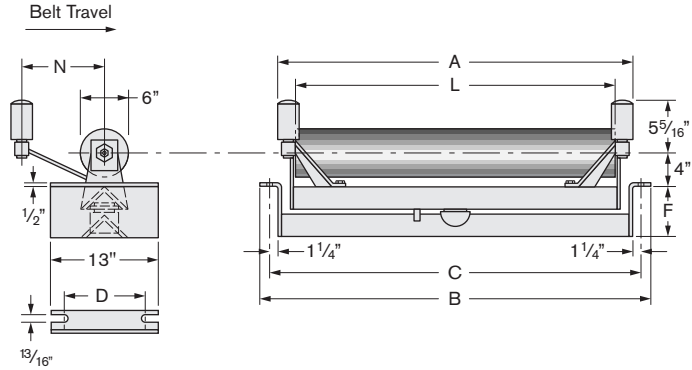

Dimensions in Inches — Average Weight in Pounds

Belt Width	A	B	C	D Minimum	F	L	N	Idler Weight	
								6" Roll	7" Roll
36	42 3/8	47 1/2	45	9	7 1/16	37 7/8	10	201	228
42	48 3/8	53 1/2	51	9	7 1/16	43 3/8	10	227	258
48	54 3/8	59 1/2	57	9	7 1/16	49 3/8	10	253	287
54	60 3/8	65 1/2	63	9	7 1/16	55 3/8	15	283	310
60	66 3/8	71 1/2	69	9	7 1/16	61 3/8	15	292	332
72	78 3/8	83 1/2	81	9	9 3/8	73 3/8	15	404	454

① 1 3/4" or 4 1/4" can be furnished for wide base idlers.

RETURN BEATER IDLER

REGREASABLE FACTORY SEALED

E7046 RG E7046 FS
7-Inch Steel Rod Roll

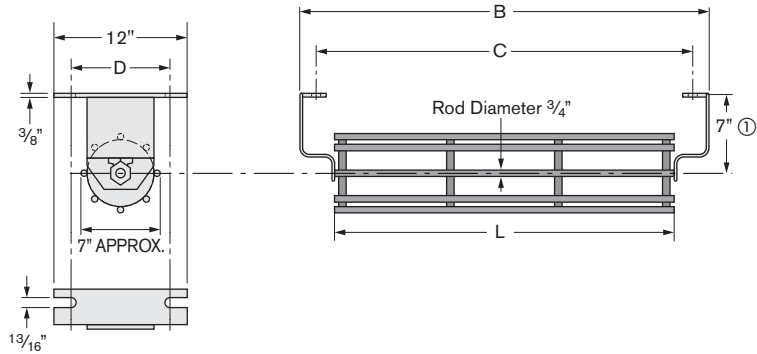

Dimensions in Inches — Average Weight in Pounds

Belt Width	B	C	D Minimum	L	Idler Weight
					7" Roll
36	48 1/4	45	9	39 7/8	109
42	54 1/4	51	9	45 7/8	121
48	60 1/4	57	9	51 7/8	133
54	66 1/4	63	9	57 7/8	146
60	72 1/4	69	9	63 7/8	158
72	84 1/4	81	9	75 7/8	183

① 1 3/4" or 4 1/4" can be furnished for wide base idlers.

Note: Dimensions subject to change. Certified dimensions of ordered material furnished on request.

LIVE SHAFT IDLERS

SERIES F

LIVE SHAFT RETURN OR FLAT IDLER

Dimensions in Inches — Average Weight in Pounds

Belt Width	B	C	D			E	L	R	S	Idler Wgt.		
			Recom.	Min.	Max.					4" Roll	5" Roll	6" Roll
18	29	27	4 ⁵ / ₈	4 ¹ / ₄	5	6	21	1/2	1 ³ / ₁₆	24	27	32
20	31	29	4 ⁵ / ₈	4 ¹ / ₄	5	6	23	1/2	1 ³ / ₁₆	27	31	38
24	35	33	4 ⁵ / ₈	4 ¹ / ₄	5	6	27	1/2	1 ³ / ₁₆	31	37	44
30	41	39	4 ⁵ / ₈	4 ¹ / ₄	5	6	33	1/2	1 ³ / ₁₆	36	42	51
36	47	45	4 ⁵ / ₈	4 ¹ / ₄	5	6	39	1/2	1 ³ / ₁₆	41	48	57
42	53	51	4 ⁵ / ₈	4 ¹ / ₄	5	6	45	1/2	1 ³ / ₁₆	47	54	65
48	59	57	4 ⁵ / ₈	4 ¹ / ₄	5	6	51	1/2	1 ³ / ₁₆	53	60	72
54	65	63	4 ⁵ / ₈	4 ¹ / ₄	5	6	57	1/2	1 ³ / ₁₆	79
60	71	69	4 ⁵ / ₈	4 ¹ / ₄	5	6	63	1/2	1 ³ / ₁₆	85

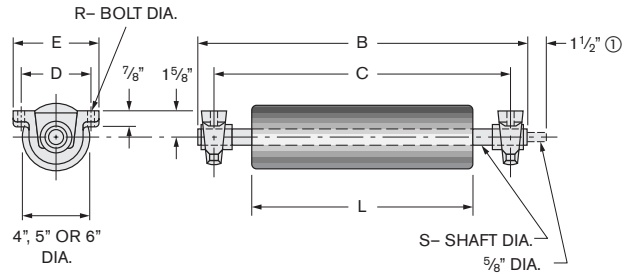

- ① Idlers with stub shaft extension are available on request.
- ② Also available in 1/4" roll wall thickness.

Note: Return Idler shown.
Rotate pillow blocks 180° for Flat Idler.

F4041

4-Inch Steel Roll

F5041

5-Inch Steel Roll

F6041

6-Inch Steel Roll ②

SERIES F – HEAVY DUTY

(Photograph on Page 6)

LIVE SHAFT FLAT IMPACT IDLER

Dimensions in Inches — Average Weight in Pounds

Belt Width	B	C	D			L	Idler Wgt.	
			Recom.	Min.	Max.		5" Roll	6" Roll
18	29 ⁷ / ₈	27	6 ¹ / ₄	6	7 ¹ / ₄	21	45	51
20	31 ⁷ / ₈	29	6 ¹ / ₄	6	7 ¹ / ₄	23	55	61
24	35 ⁷ / ₈	33	6 ¹ / ₄	6	7 ¹ / ₄	27	63	71
30	41 ⁷ / ₈	39	6 ¹ / ₄	6	7 ¹ / ₄	33	72	81
36	47 ⁷ / ₈	45	6 ¹ / ₄	6	7 ¹ / ₄	39	80	91
42	53 ⁷ / ₈	51	6 ¹ / ₄	6	7 ¹ / ₄	45	89	101
48	59 ⁷ / ₈	57	6 ¹ / ₄	6	7 ¹ / ₄	51	97	111
54	65 ⁷ / ₈	63	6 ¹ / ₄	6	7 ¹ / ₄	57	106	122
60	71 ⁷ / ₈	69	6 ¹ / ₄	6	7 ¹ / ₄	63	115	132

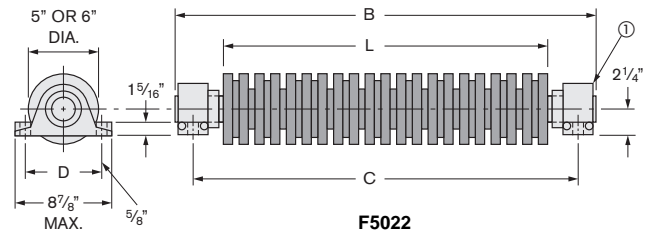

- ① Shaft is 2¹/₁₆" and has 1⁵/₁₆" roller bearing pillow blocks.
- ☐ Shaded sizes are most commonly used and are more readily available.

F5022

5-Inch Rubber Roll

F6022

6-Inch Rubber Roll

SERIES F – SUPER DUTY

LIVE SHAFT FLAT IMPACT IDLER

Dimensions in Inches — Average Weight in Pounds

Belt Width	B	C	D			L	Rise ②	Idler Wgt.
			Recom.	Min.	Max.			
30	43 ³ / ₄	39	7 ¹ / ₈	6 ⁷ / ₈	8 ³ / ₄	34	2 ¹³ / ₁₆	130
36	49 ³ / ₄	45	7 ¹ / ₈	6 ⁷ / ₈	8 ³ / ₄	40	2 ¹⁵ / ₁₆	150
42	55 ³ / ₄	51	7 ¹ / ₈	6 ⁷ / ₈	8 ³ / ₄	46	3 ¹ / ₄	170
48	61 ³ / ₄	57	7 ¹ / ₈	6 ⁷ / ₈	8 ³ / ₄	52	3 ¹ / ₂	190
54	67 ³ / ₄	63	7 ¹ / ₈	6 ⁷ / ₈	8 ³ / ₄	58	3 ¹ / ₂	210
60	73 ³ / ₄	69	7 ¹ / ₈	6 ⁷ / ₈	8 ³ / ₄	64	3 ¹ / ₂	230
72	85 ³ / ₄	81	7 ¹ / ₈	6 ⁷ / ₈	8 ³ / ₄	76	3 ¹⁵ / ₁₆	270
84	97 ³ / ₄	93	7 ¹ / ₈	6 ⁷ / ₈	8 ³ / ₄	88	—	310
96	109 ³ / ₄	105	7 ¹ / ₈	6 ⁷ / ₈	8 ³ / ₄	100	—	350

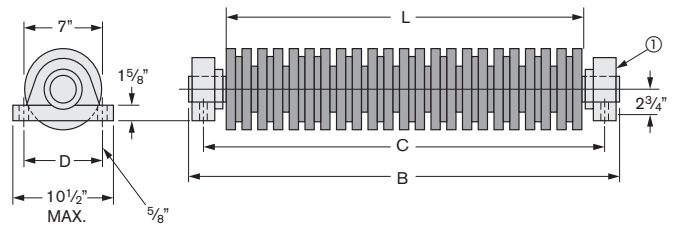

- ① Has 2²/₃₂" shaft and 2⁷/₁₆" roller bearing pillow blocks.
- ② Required rise when interspersed with Series C - 6" impact idlers.
- ☐ Shaded sizes are most commonly used and are more readily available.

F7022

7-Inch Rubber Roll

Note: Dimensions subject to change. Certified dimensions of ordered material furnished on request.

REX IDLER PROBLEM SOLVERS

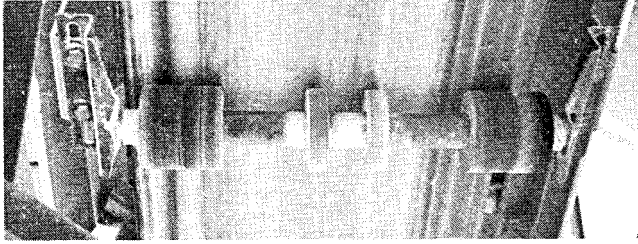

Disc Idlers

RUBBER disc idlers are designed to allow material to fall off the belt, keeping the belt clean. Used in abrasive applications where temperatures do not exceed 200°F.

URETHANE disc idlers provide longer life due to higher wear resistance. Temperatures not to exceed 200°F.

CERAMIC disc idlers are recommended for extremely abrasive applications. Temperatures not to exceed 200°F.

NOTE: Ceramic is brittle and must be handled with care.

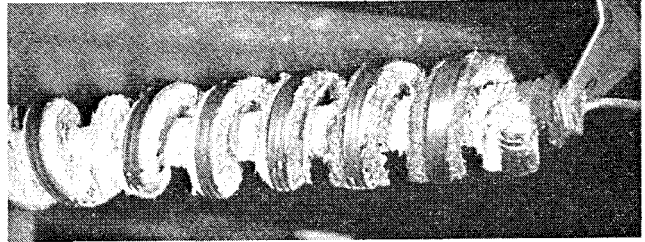

Spiral Idlers

The unique **SPIRAL** return idler has an ever changing point of contact, providing a scrubbing action to resist material build-up. In most applications, four or five spiral idlers after the head pulley will adequately clean the belt. Temperatures not to exceed 200°F.

NOTE: Should not be used on reversing conveyors.

ABRASION

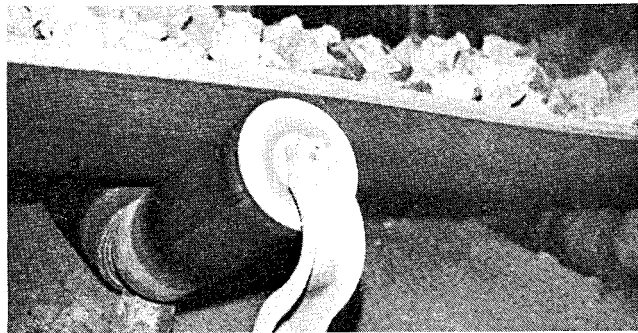

Coated Rolls

Steel rolls can be coated to provide extended roll life:

RUBBER for corrosion and material build-up. Temperature not to exceed 200°F.

URETHANE for corrosion and abrasion. ¼" and ⅝" coating is available (⅜" available up to 40" only.) Temperature not to exceed 200°F.

CERAMIC for corrosion and extreme abrasion. Standard thickness is .010". Temperatures not to exceed 200°F.

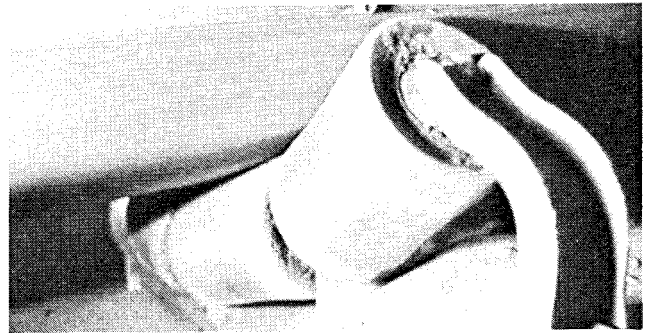

Polyethylene Roll Idlers

Polyethylene roll idlers resist corrosion and material build-up. Temperatures not to exceed 160°F. Refer to pages 44 -46.



Return Idler

Six inch steel return idlers are available in ¼" wall at a nominal premium for abrasive and corrosive applications. Available in B+, C, D and E.

REX IDLERS

TO ORDER COMPLETE ROLL ASSEMBLIES, SPECIFY:

Steel Roll Assembly

Idler Model Number
Regreasable or Factory Sealed

(If Model Number is not known, specify idler series, belt width, roll diameter and length)



Steel Roll

Impact Roll Assembly

Idler Model Number
Regreasable or Factory Sealed

(If Model Number is not known, specify idler series, belt width, roll diameter and length)



Impact Roll

Spiral Roll Assembly

Idler Model Number
Regreasable or Factory Sealed

(If Model Number is not known, specify idler series, belt width and roll diameter)

Spiral Clincher Strip Only

Idler Series
(Available in 50-foot coils only)



Spiral Return Roll

Disc Roll Assembly

Idler Model Number
Regreasable or Factory Sealed

(If Model Number is not known, specify idler series, belt width and roll diameter)

Discs Only

Idler Series and Roll Diameter
Rubber, Urethane or Ceramic



Disc Roll

Urethane Covered Roll Assembly

Idler Model Number
Regreasable or Factory Sealed

(If Model Number is not known, specify idler series, belt width, roll diameter and length)



Urethane Covered Roll

Ceramic Coated Roll Assembly

Idler Model Number
Regreasable or Factory Sealed

(If Model Number is not known, specify idler series, belt width, roll diameter and length)



Ceramic Coated Roll

Polyethylene Roll Assembly

Idler Model Number
Regreasable or Factory Sealed

(If Model Number is not known, specify idler series, belt width, roll diameter and length)



Polyethylene Roll

REX IDLERS

SERIES B (Old Pre 97) IDLER IDENTIFICATION BRACKETS

PRE 97 (OLD) CEMA B NUT

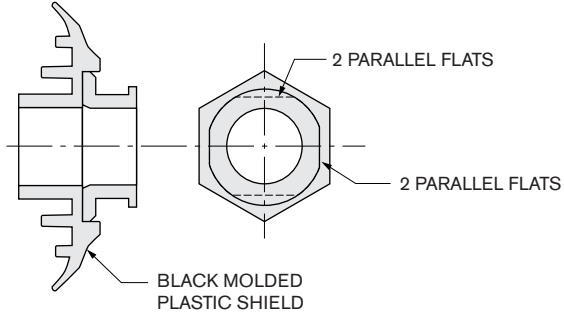

NEW CEMA B NUT

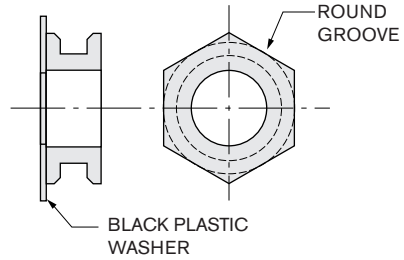

(OLD STYLE) DROP BRACKETS SERIES B

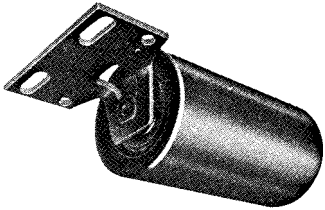

Standard 1 1/2" Drop (shown)
Part No. 111-20130-01
Optional 3" Drop
Part No. 111-20083-01

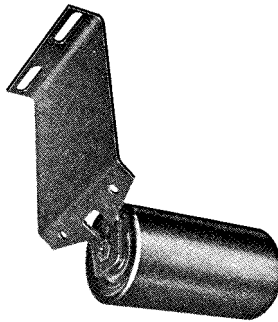

Optional 1 3/4" Drop (shown)
Part No. 111-20132-01
Optional 4 1/4" Drop
Part No. 111-20131-01

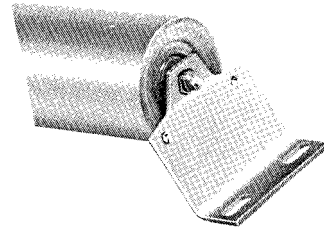

Standard 4 1/4" Rise/Drop Combination
Part No. 111-20084-01
Optional 1 1/2" Rise #111-20082-01
Optional 3" Rise #111-20083-01

REX IDLERS

SERIES B, B+, C and D

IDLER IDENTIFICATION, BRACKETS AND SEAL KITS

CEMA B NUT

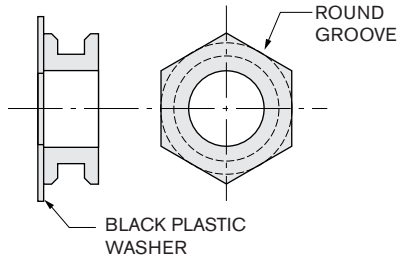

CEMA B+, C and D NUT

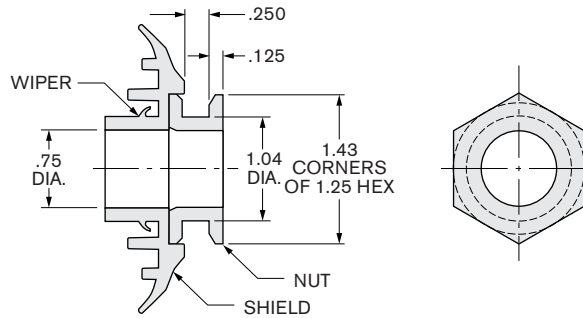

DROP BRACKETS SERIES B, B+, C & D

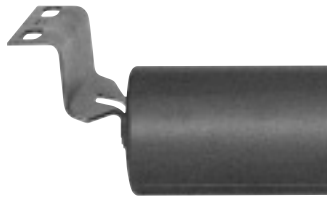

Standard 4 1/2" Drop (shown)
Part No. 101-60672-1

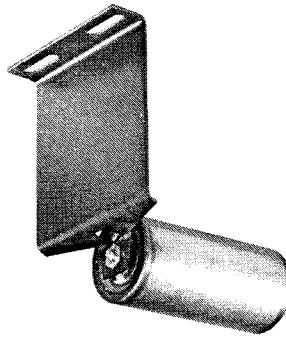

Optional 11 1/4" Drop (shown)
Part No. 101-60672-2

Optional 16 1/2" Drop
Part No. 101-60672-9

RISE BRACKETS SERIES B, B+, C & D

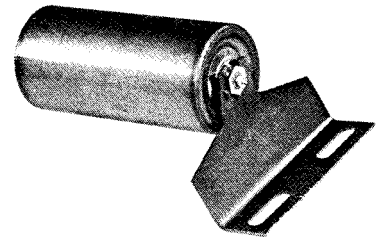

Standard 4 1/4" Rise
Part No. 101-60676-1

REVERSE DROP BRACKET SERIES B, B+, C & D



4 1/2" Drop Only
These brackets are used to allow more belt fleet.
Part No. 101-60673-5

Series B+, C and D (Excluding spiral and disc designs - contact factory) .750" Bearing Bore

To order, specify
Part #611-21084-01

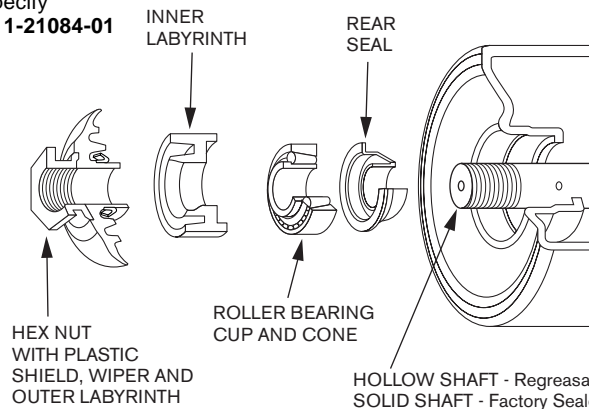

To order kit for previous design — Part #601-2901-1
(Hex nut without plastic shield)

REX IDLERS

SERIES B, B+, C and D

IDLER IDENTIFICATION, BRACKETS AND SEAL KITS

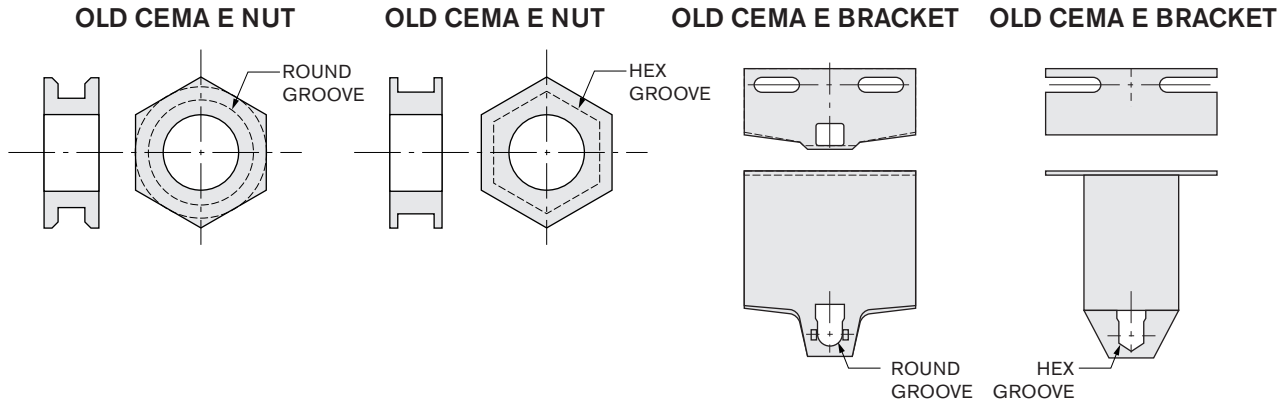

DROP BRACKETS SERIES E

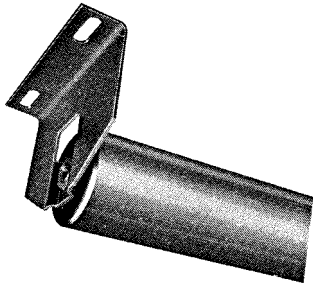

Standard 7" Drop (shown)
Part No. 111-20026-01
Optional 4½" Drop
Part No. 111-20026-04

RISE BRACKETS SERIES E

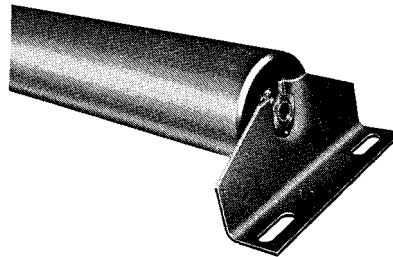

Standard 4" Rise
Part No. 111-20024-01

Series "E" Labyrinth Seal with Wiper 1.250" Bearing Bore

To order either the roller bearing or the labyrinth seal, the entire kit must be ordered.
Specify series E part number **601-3901-1**.
Seal Kit contains Bearings and Seals for one complete roll.

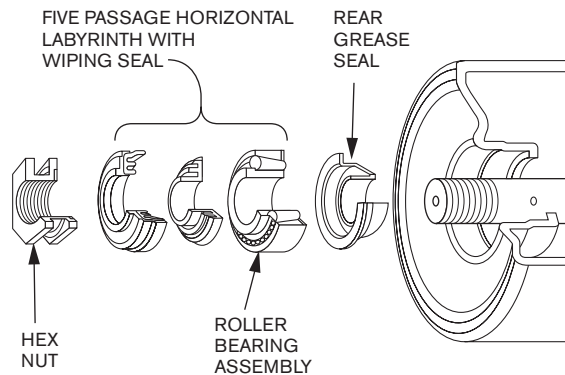

REX BELT IDLERS INTERCHANGEABILITY

To convert any standard CEMA B, B+, C and D troughing idler to belt width plus 14", 15", or 16".

Order proper idler clip.

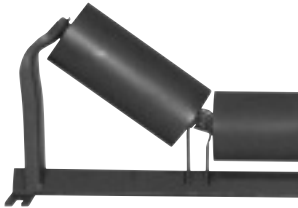

Belt Width Plus

14"

15"

Clip No.

101-60685-1

101-60685-2

These clips can be welded on standard idlers as shown.

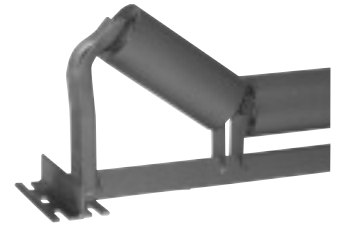

To Convert Troughing Idlers to Impact Idlers

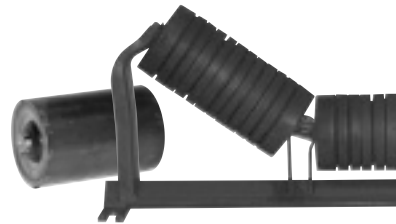
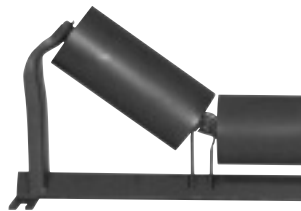

Remove the steel rolls and replace with impact rolls.
NOTE: Both 5" and 6" diameter rolls are interchangeable.

TRAINING IDLERS

To Convert Return Training Idlers to Flat Training Idlers Remove the Hanger Brackets



Convert positive type return trainer to flat training idler by removing the hanger brackets.

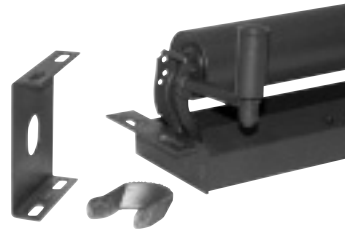

Convert actuating type return trainer to flat training idler by removing the hanger brackets.

Conversion of Positive Type to Actuating Shoe Type Training Idler

Convert any "positive" type training idler to "actuating shoe" type training idler by removing the positive arms and adding actuating shoes to the end brackets.

Actuating shoes vary with roll diameter

Roll Dia.

4"-5"

6"

Part No.

411-20009-01

411-20010-01

NOTE: Bolt holes are provided on all positive trainers for conversion to actuating shoe.

Use 5/16 x 1 Hex Hd. Cap Screw and Nut

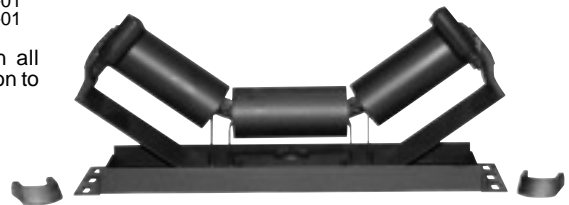

REX CATENARY IDLERS

The Rex Catenary Idler is designed to handle wet, sticky or hot materials in such applications as glass plants, fertilizer plants, quarries and food processing operations. Rubber rolls and steel cable in the roll element resist material buildup through continuous flexing action. Overall flexibility of the roll assembly provides smooth han-

dling of lumpy materials. End bearings are double-sealed and factory lubricated for minimum maintenance. The roll is suspended from a mounting hook and swivel assembly which offers additional flexibility and exceptional ease in installation.



ROLL BENEFITS

Bearings and Seals

- Assure longer life due to double contact seal.
- Last longer due to downward position which ejects troublesome dirt.
- Run cooler away from the hot belt.
- Improves belt life by preventing belt contamination by leaking grease.
- Reduce maintenance — only two bearings per idler.

Rolls

- Resist buildup because of flexing action.
- More versatile — can rotate either direction.
- Reduce belt damage — rubber roll surface cannot cut belt covers.
- Give longer life since they are corrosion resistant.
- Provide smooth flowing ride when handling lumpy material.

BASE BENEFITS

Mounting Hook and Swivel

- Permits roll to adapt to varying load conditions by allowing greater roll articulation.
- Assures easy roll installation.

Base Pipe

- Rectangular pipe provides structural strength.

End Stands

- Absorb maximum loads since the rectangular shape gives added strength in the direction of maximum loads.

INSTALLATION

It is essential that the brackets be installed in a straight line and square with the center line of the conveyor. Upon installation, if the idler does not contact the troughed belt completely across its width, it will be necessary to increase the spacing between the idlers to drop the belt or shim up the brackets; in some cases, both of the procedures may be necessary.

When installing an idler next to a conventional steel idler roll, the backing dimension (height at the center of the idler) should be 1/2- to 1-inch higher than the center of the steel idler, as measured from the deck on the top of the roller.

Height of the drive and tail pulleys also is important in relation to the top of the center of the idler. The top of the center should be 1/2- to 1-inch higher than the top of the pulley.

Rex Catenary Idlers should be applied using the 20-degree troughing idler capacity charts on page 74. Use the chart below to determine proper idler spacing.

Material Weight in Lbs./Cu. Ft.	Maximum Lump Size — Inches	Troughing Idler Spacing — Feet	Return Idler Spacing — Feet
20-50	5	6	10
55-70	4	6	10
75-125	3	5	10

REX CATENARY IDLERS

CATENARY TROUGHING IDLER

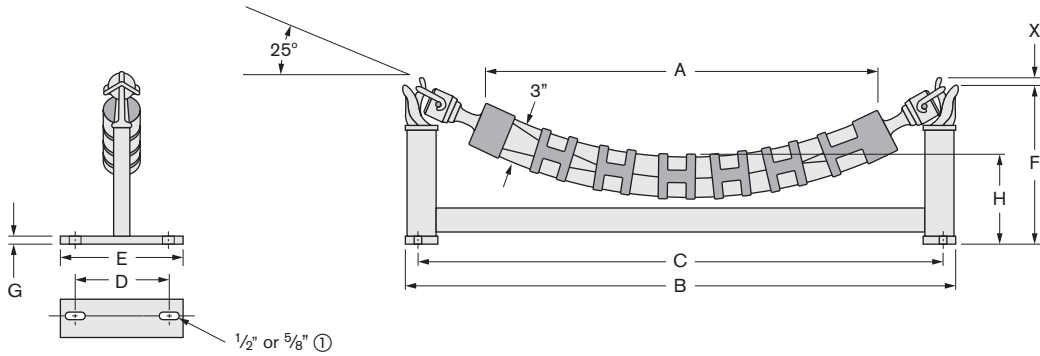

O3204
3-Inch Rubber Roll

Dimensions in Inches — Average Weight in Pounds

Belt Width	A	B	C	D			E	F	G	H	X	Weight
				Recom.	Min.	Max.						
18	19½	29¾	27	4½	4	5	6⅞	10¾	¾	8¼	1⅝	30
20	21½	31¾	29	4½	4	5	6⅞	10⅞	¾	8¼	1⅝	31
24	25½	35¾	33	4½	4	5	6⅞	11⅞	¾	8¼	1⅝	34
30	31¼	41	39	7½	7	8	9⅞	12⅝	¾	9	1⅝	43
36	37¼	47	45	7½	7	8	9⅞	13	¾	9	1⅝	46

① Use washers on ½-inch bolts.

CATENARY RETURN IDLER

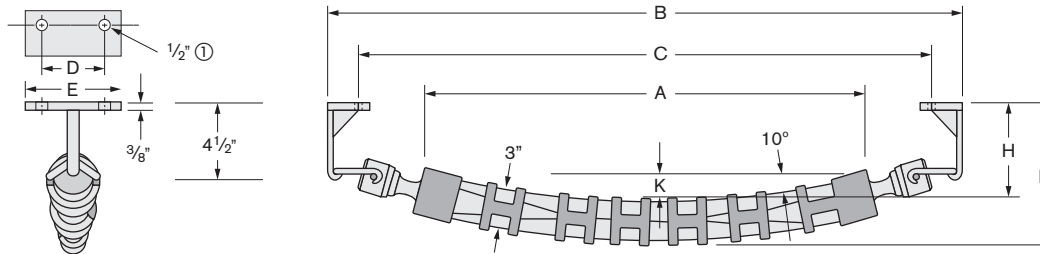

O3144
3-Inch Rubber Roll

Dimensions in Inches — Average Weight in Pounds

Belt Width	A	B	C	D	E	F	H	K	Weight
18	20⅞	31	27	5	6	6⅞	3⅞	⅞	15
20	22⅞	33	29	5	6	7⅞	4⅞	1⅞	15
24	26⅞	37	33	5	6	7⅞	4⅞	1⅞	16
30	31⅞	42¼	39	5	6	7⅞	4⅞	1⅞	18
36	38	48¼	45	5	6	7⅞	4⅞	1½	20

① Use washers on ½-inch bolts.

SOLID SHAFT RETURN IDLER

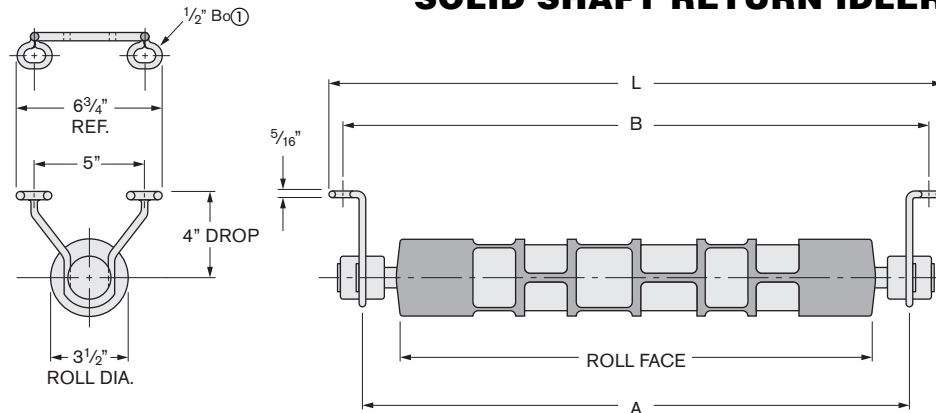

O4044
3½-Inch Rubber Roll

Belt Width	Roll Face	Dimensions In Inches		
		A	B	L
18	21¾	24⅞	27	28⅞
20	23¾	26⅞	29	30⅞
24	27¾	30⅞	33	34⅞
30	33¾	36⅞	39	40⅞
36	39¾	42⅞	45	46⅞

① Use washers on ½-inch bolts.

Note: Dimensions subject to change. Certified dimensions of ordered material furnished on request.

REX IDLERS

WEIGHT OF ROTATING PARTS FOR STEEL ROLLS

The weights of rotating parts of the idler rolls are used in determining the additional forces required to overcome roller friction. For convenience, the following tabulation of average weights of rotating parts may be used in these calculations. The weights listed include only the rotating parts of the carrying and return rolls.

Series No.	Roll Diameter	Belt Width Inches	Troughing Idlers Lbs.	Flat or Return Idlers Lbs.
B	4 inch	18	13.42	11.58
		20	14.43	12.59
		24	16.46	14.62
		30	19.50	17.66
		36	22.55	20.71
		42	25.59	23.75
B	5 Inch	48	28.64	26.80
		18	16.18	14.70
		20	17.46	15.98
		24	20.02	18.54
		30	23.85	22.37
		36	27.69	26.21
B+, C and D	5 Inch	42	31.52	30.04
		48	35.36	33.88
		18	18.61	15.21
		20	19.90	16.50
		24	22.47	19.07
		30	26.33	22.93
C and D	6 Inch	36	30.19	26.79
		42	34.05	30.65
		48	37.91	34.51
		54	41.77	38.37
		60	45.63	42.23
		18	23.10	20.26
E	6 Inch	20	24.81	21.97
		24	28.24	25.40
		30	33.38	30.54
		36	38.52	35.68
		42	43.66	40.82
		48	48.81	45.97
E	6 Inch	54	53.95	51.11
		60	59.09	56.25
		36	62.6	54.8
		42	70.3	62.5
		48	78.0	70.1
		54	85.7	77.8
E	7 Inch	60	93.4	85.5
		72	108.7	100.8
		84	124.0	116.2
		96	139.4	131.5
		36	60.8	60.1
		42	69.8	69.1
E	7 Inch	48	78.9	78.1
		54	87.9	87.1
		60	96.9	96.1
		72	114.9	114.2
		84	132.9	132.2
		96	150.9	150.2

REX IDLERS

SELECTION OF BELT CONVEYOR IDLERS Determination of Belt Width and Speed

Belt width and belt speed can be determined by using the material characteristics and required conveyor capacity.

Basis for Selection

Required Conveyor Capacity — Amount of material to be handled, (tons per hour). This figure should reflect peak or surge volume rather than average volume.

Material Characteristics — A precise description of the material to be handled. The description should include the following:

- A. **Material Weight** — In pounds per cubic foot. (Table 1, pages 72-73)
- B. **Maximum Lump Size** — (largest measurement) and percentage of lumps and fines.
- C. **Flowability of the Material** — Free-flowing, average or sluggish.
- D. **Abrasiveness of Material** — Non-abrasive, mildly abrasive or very abrasive. (Table 1, pages 72-73).
- E. **Corrosiveness of Material** — Non-corrosive, mildly corrosive or very corrosive. (Table 1, pages 72-73).
- F. **Surcharge Angle** — This is the angle from the horizontal assumed by the conveyed material as it is carried on a belt passing over idlers. The surcharge angle is normally 5° to 15° less than the angle of repose.
- G. **Angle of Repose** — This is the angle from the horizontal assumed by the material in a freely formed pile on a horizontal surface.

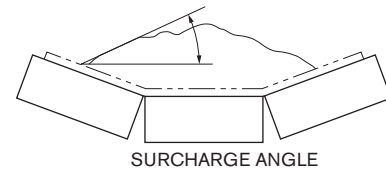
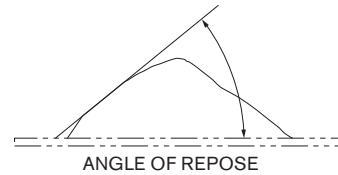

Selection Procedure

1. From Tables 2, 3, or 4 (pages 74-76) — Determine the **minimum belt width** based on lump size, surcharge angle and percentage of lumps and fines. (The minimum belt width is the same for any troughing angle.) Read down the appropriate right hand column until the required lump size is reached — then read across to the left hand column for minimum belt width.
2. From Tables 2, 3 or, 4 (pages 74-76) — Refer to the footnotes and select the symbol which most closely represents the material to be conveyed based on flowability and abrasiveness.

Next, determine the design capacity. The capacities shown in the tables are based on material weight of 100 pounds per cubic foot. For other materials, use the following formula to convert required capacity to design capacity:

$$\frac{100 \times \text{Required Capacity (TPH)}}{\text{Actual Material Wgt. (Lbs/Cu.Ft.)}} = \text{Design Capacity (TPH)}$$

To find **maximum belt speed**, enter the table at the belt width from paragraph 1 and read to the right until the selected symbol is reached. Then read down - following the selected symbol across columns if necessary - to the required design capacity at the proper surcharge angle. Normal belt speed is usually 100-200 fpm less than the maximum.

3. To determine **optimum** belt width and speed - deduct at least 100 fpm and increase belt width as required.

NOTES: Do not select any belt width narrower than minimum belt width determined in Step 1.

Do not select any belt speed faster than maximum belt speed determined in Step 2.

A minimum belt speed of 300 fpm is recommended for proper discharge from 35° and 45° troughed belts.

REX IDLERS

TABLE 1A – CEMA MATERIAL CLASS DESCRIPTION

Weights and Conveying Characteristics of Materials

Table (1A) lists CEMA material class descriptions and corresponding codes referred to in Table (1). Table (1) lists typical values. Some materials, particularly ores, vary widely. Weight and angle of repose depend largely on the size distribution in a given material. Degree of aeration may be important factor in density of very fine material. Angle of repose may increase with the percentage of fines as well as the angularity of the particles. Fines carry most of the moisture content, which is often the controlling factor. For these reasons, the values given can only be approximate.

	Material Characteristics	Code
SIZE	Very fine – 100 mesh and under	A
	Fine – 1/8 inch and under	B
	Granular – under 1/2 inch	C
	Lumpy – containing over 1/2 inch	D
	Irregular – stringy, interlocking, mats together	E
FLOWABILITY ANGLE OF REPOSE	Very free flowing – angle of repose than 20°	1
	Free flowing – angle of repose 20° to 30°	2
	Average flowing – angle of repose 30° to 45°	3
	Sluggish – angle of repose 45° and over	4
ABRASIVENESS	Non-abrasive	5
	Abrasive	6
	Very abrasive	7
	Very sharp – cuts or gouges belt covers	8
MISCELLANEOUS CHARACTERISTICS (Sometimes more than one of these characteristics may apply.)	Very dusty	L
	Aerates and develops fluid characteristics	M
	Contains explosive dust	N
	Contaminable, affecting use of saleability	P
	Degradable, affecting use of saleability	Q
	Gives off harmful fumes or dust	R
	Highly corrosive	S
	Mildly corrosive	T
	Hygroscopic	U
	Interlocks of mats	V
	Oils or chemicals present – may affect rubber products	W
	Packs under pressure	X
	Very light and fluffy – may be wind swept	Y
	Elevated temperature	Z

**Table 1
Conveying Properties of Materials
(For Additional Information See CEMA Handbook)**

Material	Lbs. per Cu. Ft.	Angle of Repose	Recom'd Max. Incln.	Code	Material	Lbs. per Cu. Ft.	Angle of Repose	Recom'd Max. Incln.	Code
Alfalfa meal	17	45°	...	B46Y	Carborundum, 3" and under	100	20-29°	...	D27
Alum, fine	45-50	30-44°	...	B35	Casein	36	30-44°	...	B35
Alum, lumpy	50-60	30-44°	...	D35	Cast iron chips	90-120	45°	...	A46
Alumina	50-65	22°	10-12°	B27M	Cement, Portland	72-99	30-44°	20-23°	A36M
*Aluminum chips	7-15	45°	...	E46Y	Cement, Portland, aerated	60-75	A16M
Aluminum hydrate	18	34°	20-24°	C35	Cement, rock (see limestone)	100-110	D36
Aluminum oxide	70-120	29°	...	A27M	Cement clinker	75-95	30-40°	18-20°	D37
Aluminum silicate	49	30-44°	...	B35S	Chalk, lumpy	75-85	45°	...	D46
Aluminum sulphate	54	32°	17°	D35	*Charcoal	18-25	35°	20-25°	D36Q
Ammonium chloride, crystalline	45-52	30-44°	...	B36S	Chrome ore (chromite)	125-140	30-44°	...	D37
Ammonium nitrate	45	30-44°	...	*C36NUS	Cinders, blast furnace	57	35°	18-20°	*D37T
Ammonium sulphate, granular	45-58	44°	...	*C35TU	Cinders, coal	40	35°	20°	*D37T
Asbestos, ore or rock	81	30-44°	...	D37R	Clay, calcined	80-100	B37
Asbestos, shred	20-25	45°	...	E46XY	Clay, dry, fines	100-120	35°	20-22°	C37
Ashes, coal, dry, 3" and under	35-40	45°	...	D46T	Clay, dry, lumpy	60-75	35°	18-20°	D36
Ashes, coal, wet, 3" and under	45-50	45°	...	D46T	Coal, anthracite, sized	55-60	27°	16°	C26
Ashes, fly	40-45	42°	20-25°	A37	Coal, bituminous, mined 50 mesh and less	50-54	45°	24°	B45T
Ashes, gas-producer, wet	78	D47T	Coal, bituminous, mined and sized ..	45-55	35°	16°	D35T
Asphalt, binder for paving	80-85	C45	Coal, bituminous, mined, run of mine	45-55	38°	18°	D35T
Asphalt, crushed, 1/2" and under	45	30-44°	...	C35	Coal, bituminous, stripping, not cleaned	50-60	D36T
					Coal, lignite	40-45	38°	22°	D36T
Bagasse	7-10	45°	...	E45Y	Coke, loose	23-35	30-44°	18°	B37QVT
Bakelite and similar plastics, powdered	35-45	45°	...	B45	Coke, petroleum calcined	35-45	30-44°	20°	D36Y
Barite	180	30-44°	...	B36	Coke breeze, 1/4" and under	25-35	30-44°	20-22°	C37Y
Barium carbonate	72	45°	...	A45	Compost	30-50	E45ST
Barium oxide	150-200	A46	Concrete, cinder	90-100	...	12-30°	D46
*Bark, wood, refuse	10-20	45°	27°	E45VY	Copper ore	120-150	30-44°	20°	*D37
Basalt	80-103	20-28°	...	B26	Copper sulfate	75-85	31°	17°	D36
Bauxite, ground, dry	68	20-29°	20°	B26	Cork, granulated	12-15	C45
Bauxite, mine run	80-90	31°	17°	E37	Corn, shelled	45	21°	10°	C25NW
Bauxite, crushed, 3" and under	75-85	30-44°	20°	D37	Cottonseed cake, crushed	40-45	30-44°	...	B35
*Bentonite, crude	35-40	42-44°	...	D36X	Cottonseed cake, lumpy	40-45	30-44°	...	D35W
Bentonite, 100 mesh and under	50-60	42°	20°	A36XY	Cottonseed meal	35-40	35°	22°	B35W
Boneblack, 100 mesh and under	20-25	20-29°	...	A25Y	Cottonseed meats	40	30-44°	...	B35W
Bonechar	27-40	30-44°	...	B36	Cryolite, dust	75-90	30-44°	...	A36
Bonemeal	50-60	30-44°	...	B36	Cryolite, lumpy	90-100	30-44°	...	D36
Borate of lime	60	30-44°	...	A35	Cullet	80-120	30-44°	20°	D37Z
Borax, 1/2" screenings	55-60	30-44°	...	C36					
Borax, 3" and under	60-70	30-44°	...	D35	Diatomaceous earth	11-14	30-44°	...	A36MY
Boric acid, fine	55	20-29°	...	B26T	Dicalcium phosphate	40-50	45°	...	A45
Brewer's grain, spent, dry	25-30	45°	...	C45	Disodium phosphate	25-31	30-44°	...	B36QT
Brewer's grain, spent, wet	55-60	45°	...	C45T	Dolomite, lumpy	80-100	30-44°	22°	D36
Calcium carbide, crushed	70-80	30-44°	...	D36N	Earth, as excavated — dry	70-80	35°	20°	B36
Carbon, activated, dry, fine	8-20	20-29°	...	B26Y	Earth, wet, containing clay	100-110	45°	23°	B46
Carbon black, pelletized	20-25	25°	...	B25Q	Ebonite, crushed 1/2" and under	65-70	30-44°	...	C35
Carbon black, powder	4-7	30-44°	...	*A35Y	Emery	230	20-29°	...	A27
					Epson salts	40-50	30-44°	...	B35

* May vary considerably – consult a CEMA member

REX IDLERS

SELECTION PROCEDURE —from CEMA Standard 502-1998

Step 5. K3B = Effect of roll diameter on predicted bearing life

For a given belt speed, using larger diameter rolls will increase idler L_{10} life. Figure 10 depicts L_{10} life adjustment for various roll diameters using a 4" diameter as a value of 1.0. Percent life increase can be calculated for each roll diameter increase.

Example: $\frac{1.5 \text{ for 6" dia.}}{1.25 \text{ for 5" dia.}} = 1.20$ for 20% increase in L_{10} life.

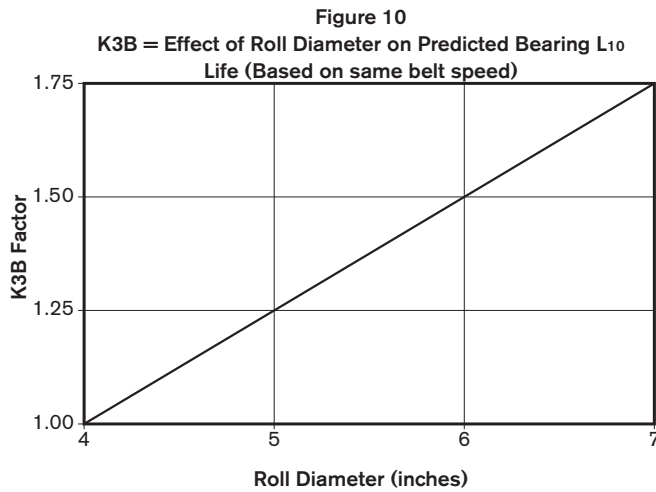

Step 6. K4 = Environmental, maintenance, and other conditions

Figure 11 K4A - Effect of maintenance on potential idler life

Figure 12 K4B - Effect of environment on potential idler life

Figure 13 K4C - Effect of operating temperature on potential idler life

Based on collective application experience by CEMA idler manufacturers, these conditions are very important in determining potential idler life. However, exact mathematical basis is very subjective, so contact Rexnord for assistance, or for any unusual conditions not listed.

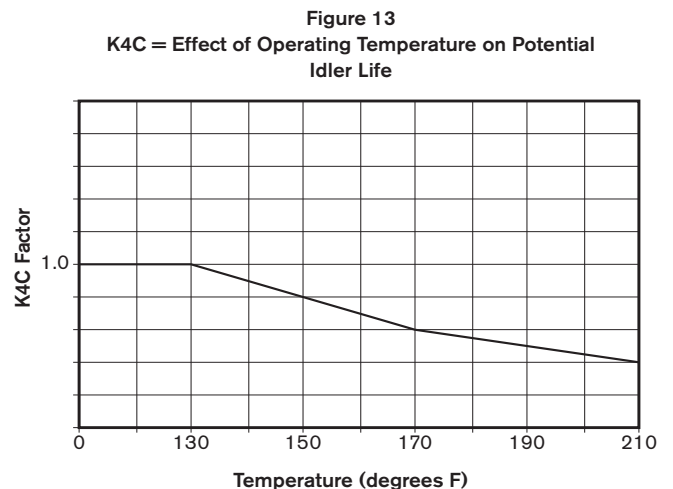
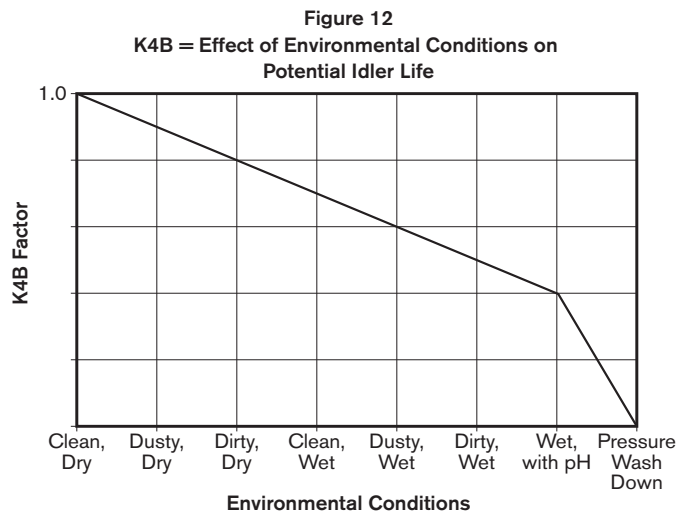
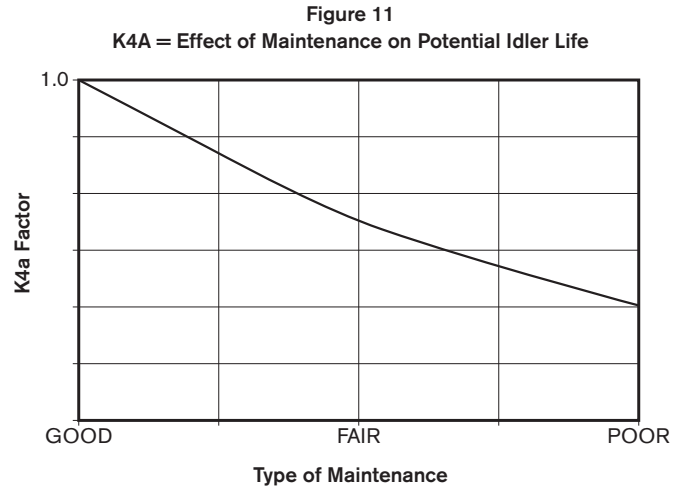

REX IDLERS

SELECTION PROCEDURE —Cont'd

Table 15
Idler Roll Recommendations

Material Characteristics	Idler Roll Recommendations	
	Troughing or Flat	Return
NA — Non Abrasive MA — Mildly Abrasive NC — Non Corrosive MC — Mildly Corrosive	Standard — Steel	Standard — Steel
VA — Very Abrasive	Larger roll diameter Thicker roll shell — steel Coated roll (Ceramic) Rubber cover or Urethane cover	Rubber, Urethane, Ceramic Disc or Rubber Spiral Thicker roll shell — steel Larger roll diameter Coated roll (Ceramic) Rubber cover or Urethane cover
VC — Very Corrosive	Thicker roll shell — steel Coated roll (Ceramic) Rubber cover or Urethane cover Polyethylene	Thicker roll shell — steel Coated roll (Ceramic) Rubber cover or Urethane cover Rubber, Urethane, Ceramic Disc or Rubber Spiral Polyethylene
Materials which adhere to belt and idlers.	Rubber Disc or Urethane disc Catenary Rubber cover or Urethane cover Polyethylene	Rubber or Urethane Disc or Rubber Spiral Catenary Polyethylene

Table 16
Terminals — Distance between nearest standard carrying idler and pulley.

Carrying Idler Spacing at Terminals		
Troughing Angle	Distance in Inches Pulley to closest standard idler	Transition Idlers — If distance to the closest standard idler is greater than the recommended spacing in table 17 below, the use of the following transition idlers are recommended.
20°	1.0 x belt width	...
35°	1.5 x belt width	20° idler
45°	2.0 x belt width	20° idler and 35° idler

Table 17
Recommended Minimum Transition Distance

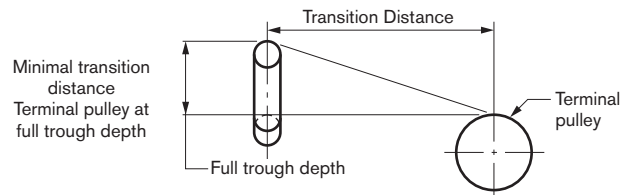
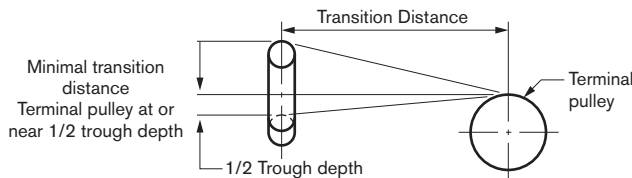

Idler Angle	% Rated Tension	Fabric Belts	Steel Cable Belts
20°	Over 90	.9b	2.0b
	60 to 90	.8b	1.6b
	Less than 60	.6b	1.0b
35°	Over 90	1.6b	3.4b
	60 to 90	1.3b	2.6b
	Less than 60	1.0b	1.8b
45°	Over 90	2.0b	4.0b
	60 to 90	1.6b	3.2b
	Less than 60	1.3b	2.3b

Idler Angle	% Rated Tension	Fabric Belts	Steel Cable Belts
20°	Over 90	1.8b	4.0b
	60 to 90	1.6b	3.2b
	Less than 60	1.2b	2.8b
35°	Over 90	3.2b	6.8b
	60 to 90	2.4b	5.2b
	Less than 60	1.8b	3.6b
45°	Over 90	4.0b	8.0b
	60 to 90	3.2b	6.4b
	Less than 60	2.4b	4.4b

b = Belt width

REX IDLER SPECIFICATIONS

REGREASABLE IDLERS

Regreasable idlers are designed to provide positive thru-lubrication to all bearings from a single fitting and are recommended for those installations where a regular re-lubrication program is scheduled.

Series B+

Idlers are Rexnord Light Duty type conforming to the dimension requirements for CEMA B. The idlers exceed CEMA B Load Ratings by utilizing a CEMA C roll.

4" and 5" diameter rolls are manufactured from #9 gauge (.149") welded steel tubing, counterbored for deep drawn steel end discs which are welded in place assuring concentricity and balance. Total indicated runout to be .030" or less. Rolls shall have 3/4" hollow shafts to permit thru greasing and 3/4" tapered roller bearings designed to operate at 100% of the CEMA C rated idler load. Seals shall be of the five passage horizontal labyrinth with wiper type. The combination outer seal and shield and inner seal are close tolerance injection molded non-metallic components.

The idler frame shall consist of an inverted angle, formed end and center brackets with slotted mounting pads. Frame strength shall be equal or greater than the CEMA B idler load ratings.

Gap between the center and end roll shall not exceed the following:

Roll Diameter Inches	Trough Angle	
	20°	35°
4	1/2"	17/32"
5	9/32"	5/16"

Positive roll retention locks are provided for end and center rolls. Roll locks are easily removeable for roll replacement. Both ends of the idler are equipped with a ball check type grease fitting to allow lubrication from either side of the idler.

Series C & D Troughing Idler

Idlers are Rexnord Medium Duty type conforming to the requirements for CEMA C in dimension. Rex Idlers meet or exceed CEMA load rating requirements. Available with 5" and 6" diameter rolls with single point thru-greasing.

Rolls shall be manufactured from welded steel tubing. The 5 inch diameter roll shall have a wall thickness of #9 gauge (.149") and the 6 inch diameter roll shall have a wall thickness of #8 gauge (.165"). The roll shell shall be counterbored for deep drawn steel end discs which will be welded in place assuring concentricity and balance. T.I.R. to be .030" or less. Rolls shall have 3/4" diameter hollow shafts (1" diameter for Series D); to permit thru-greasing and 3/4" tapered roller bearings designed to operate at 100% of the rated idler load. Seals shall be of the five passage horizontal labyrinth with wiper type. The combination outer seal and shield and inner seal are close tolerance injection molded non-metallic components.

The idler frame shall consist of an inverted steel angle, end and center brackets and slotted mounting pads. Frame strength shall be equal to or greater than the CEMA D idler load ratings.

Gap between the center and end roll shall not exceed the following:

Roll Diameter Inches	Trough Angle		
	20°	35°	45°
5	5/16"	9/32"	5/16"
6	3/8"	7/32"	3/16"

Positive retention heavy duty roll locks are to be provided for end and center rolls and are to be easily removable for roll replacement. Center roll locks are to provide support and protection for the thru-grease connector tube.

Both ends of the idler are equipped with a ball check type grease fitting to allow lubrication from either side of the idler.

Series E Troughing Idler

Idlers are Heavy Duty type conforming to the requirements for CEMA E in dimensions and load rating and are available with 6" and 7" diameter rolls with single point thru-greasing.

Rolls are manufactured from 1/4" welded steel tubing, counterbored for deep drawn steel end discs which will be welded in place assuring concentricity and balance. T.I.R. to be .040". Rolls shall have 1 1/4" diameter shafts and 1 1/4" tapered roller bearings designed to operate at 100% of the rated idler loads. Seals shall be of the triple labyrinth cartridge type with deflector caps.

The idler frame shall consist of an inverted steel angle, end and center brackets and slotted mounting pads. Frame strength shall be equal to or greater than the idler load ratings.

Roll gap between the center and end roll shall not exceed the following:

Roll Diameter Inches	Trough Angle	
	20°	35°
6	29/32"	3/4"
7	3/4"	7/16"

Positive retention heavy duty roll locks are to be provided for end and center rolls and are to be easily removable for roll replacement. Center roll locks are to provide protection for the thru-grease connector tube.

Each idler shall have a standard grease fitting on one end and a pressure relief fitting on the opposite end.

REX IDLER SPECIFICATIONS

FACTORY SEALED IDLERS

Factory sealed idlers are designed to provide longer roll life for those installations where a regular re-lubrication program will not be maintained.

Series B Troughing Idler

Idlers are Rexnord Light Duty type conforming to the dimensional requirements for CEMA B. These idlers exceed CEMA B load ratings. Available in 4" and 5" diameter rolls.

Rolls are manufactured from #9 gauge (.149") welded steel tubing, counterbored for steel end discs. The end discs are pressed into the roll shell at which time the roll ends are formed to lock the disc securely assuring concentricity and balance. The 17mm solid shaft with ball bearings has dual shields and seals. An outer shield protects the bearing from larger contaminants.

The idler frame shall consist of an inverted steel angle, formed end and center brackets and slotted mounting pads. Frame strength shall be equal to or greater than the idler load ratings.

Gap between the center and end roll shall not exceed the following:

Roll Diameter Inches	Trough Angle	
	20°	35°
4	1/2"	17/32"
5	9/32"	5/16"

Positive roll retention is to be provided for end and center rolls, to be easily removable for roll replacement.

Series C & D Troughing Idler

Idlers are Rexnord Medium Duty type conforming to the requirements for CEMA Series C in dimension. Available with 5" and 6" diameter rolls. Rex idlers meet or exceed CEMA load rating requirements.

Rolls shall be manufactured from welded steel tubing. The 5 inch diameter roll shall have a wall thickness of #9 Gauge (.149") and the 6 inch diameter roll shall have a wall thickness of #8 Gauge (.165"). The roll shell shall be counterbored for deep drawn steel end discs which will be welded in place assuring concentricity and balance. T.I.R. to be .030" or less. Rolls shall have 3/4" diameter solid shafts (1" diameter for Series D); and 3/4" tapered roller bearings designed to operate at 100% of the rated idler load. Seals shall be of the five passage horizontal labyrinth with wiper type. The combination outer seal and shield and inner seal are close tolerance injection molded non-metallic components.

The idler frame shall consist of an inverted steel angle, end and center brackets and slotted mounting pads. Frame strength shall be equal to or greater than the CEMA D idler load ratings.

Gap between the center and end roll shall not exceed the following:

Roll Diameter Inches	Trough Angle		
	20°	35°	45°
5	5/16"	9/32"	5/16"
6	3/8"	7/32"	3/16"

Positive retention heavy duty roll locks are to be provided for end and center rolls and are to be easily removable for roll replacement.

SPECIFIC FUNCTION IDLERS

Return and Flat Idlers — Return and Flat idlers are to have the same specifications for roll construction as the troughing idlers. Hanger or support brackets shall have a strength equal to or greater than the idler load rating.

Impact Idlers — Troughing — To be used where the impact force exceeds 40 foot pounds. Impact idler rolls shall be of molded rubber specifically selected for shock absorbing characteristics, with alternate deep and shallow grooving for impact absorption, and press fit onto a steel inner tube.

Impact Idlers — Flat — Flat impact idler rolls are to have the same specifications as the troughing impact rolls, except they are to be mounted on a solid steel shaft with outboard roller bearing pillow blocks.

Spiral Return Idlers — Spiral return idlers shall consist of an extruded rubber, formed to fit over a heavy steel spiral which is welded to a steel inner tube. These idlers are to be used on unidirectional conveyors only.

Rubber Disc Return Idlers — Rubber disc return idlers shall have square corner, abrasion resistant rubber discs with an encapsulated steel ring to maintain a compression fit between the disc and inner tube.

Urethane Disc Return/Idlers — Urethane disc return idlers shall have square corner, abrasion resistant urethane discs with an encapsulated steel ring to maintain a compression fit between the disc and inner tube.

Ceramic Disc Return/Idlers — Ceramic disc return idlers shall have extremely abrasion resistant ceramic discs with a urethane bushing to maintain a compression fit between the disc and inner tube.

Training Idlers (Positive Type) — Training idlers shall be provided with ball bearing activating rollers mounted on both ends of the idler frame. The idler frame shall be free to swivel within controlled limits about a pivot housing on tapered roller bearings. Belt travel one direction only.

Training Idlers (Actuating Shoe) — Training idlers shall be provided with actuating shoes mounted on both ends of the idler frame. The idler shall be free to swivel within controlled limits about a pivot housing on tapered roller bearings. Belt travel either direction.

Training Idlers (Inclined Pivot) — Training idlers shall be constructed to allow the weight of the belt to direct the roll to a belt centering position. Belt travel one direction only.

Ceramic Covered Rolls — Rolls shall be standard steel idler rolls with a ceramic covering for increased roll shell wear life. Ceramic material is not to chip off roll face until backup metal is deformed. Rolls are to be interchangeable with standard roll assemblies of the same series.

Urethane Covered Rolls — Rolls shall be standard steel idler rolls with a 1/8" or 1/4" thick bonded urethane covering for increased roll shell wear life. Rolls are interchangeable with standard roll assemblies of the same series.

Polyethylene Roll Idlers — Polyethylene rolls are made of a proprietary formulation of high molecular weight polyethylene, Teflon® and carbon black to provide a roll that resists corrosion and material build-up.

REX IDLERS

INSTALLATION, CARE AND MAINTENANCE

A belt conveyor is one of the most economical means of transporting bulk material. It can operate in almost any weather condition, and it can traverse terrain which would severely limit other means of transport. A belt conveyor system represents a substantial capital investment . . . and it must be kept running to obtain full value.

In a system, the belt can easily represent half the total conveyor cost. . . and is the most fragile part of the conveyor. The structure and various mechanical components of a system serve primarily to drive, guide, and protect the belt.

IMPORTANT — Safety Instructions

Compliance with safety standards, including OSHA and other Federal, State, local codes or regulations is the responsibility of the user of the conveyor installation. Placement of guards and other safety equipment in accordance with safety standards is dependent upon the area and use to which the system is put. A safety study should be made of the conveyor application and guards should be installed wherever appropriate. "Safety Standards For Conveyors And Related Equipment" ANSI B20.1 is a guide for safe construction, installation, operation and maintenance of conveyors and related equipment.

GENERAL RECOMMENDATIONS

1. Alignment of the structure is critical if the belt is to train properly on the idlers. Idler and pulley supports must be equidistant from the conveyor centerline and level across the conveyor width.

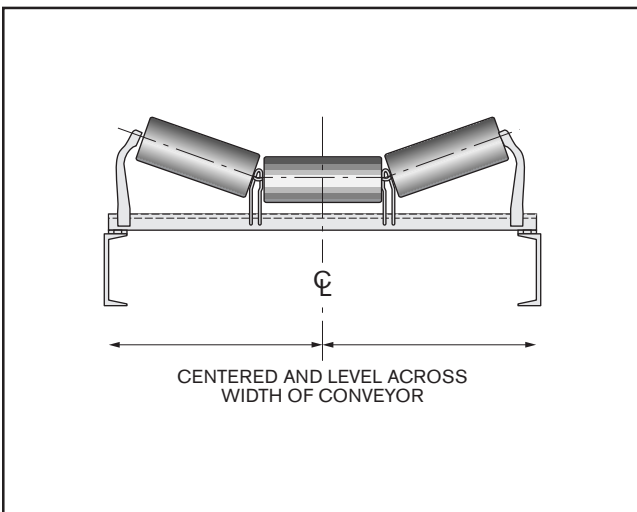

2. Pulley shaft assemblies must be square to centerline of conveyor, level and in line.
3. Belt must be properly spliced so it runs straight and true.

STORAGE AND PREPARATION

Belt conveyor idlers are usually shipped to the job site mounted on skids and shrink wrapped. As idlers often arrive well in advance of their installation, they should be stored under cover to protect them from exposure to the weather and other adverse conditions.

Prior to installation, check all idlers for evidence of damage to the rolls or frame due to mishandling. Check all rolls to make sure that they turn freely.

INSTALLATION

Place idlers in position by sliding them downstream, firmly against the mounting bolts and lightly tighten. Final alignment requires that the centerline of all idlers is in a straight line, perpendicular to the line of belt travel, properly spaced and level. When alignment is complete, bolt idlers securely in place.

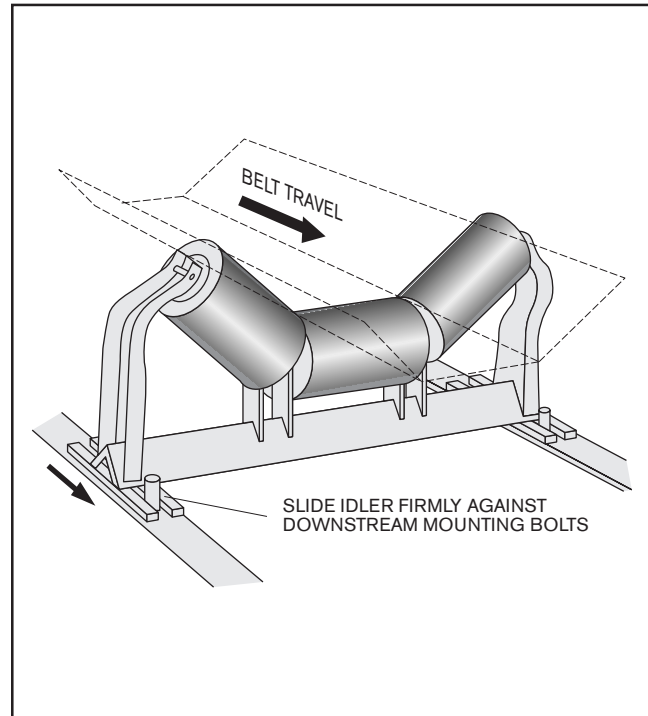

IDLER ALIGNMENT

When the idlers and belt have been installed, the system should be started while empty and checked for alignment. A properly aligned conveyor has the belt running evenly in the center of the idlers and, therefore, prevents damage to the belt edges from contact with supporting structures or other objects. If a misalignment problem exists, it is not advisable to attempt to correct it by readjusting the head or tail pulley, as this will cause undue strains on the pulley bearings, belt, belt splice or joint, and on the conveyor frames. Pulleys should be carefully aligned when installed and should not be moved for purposes of belt training. (Continued)

REX IDLERS

INSTALLATION, CARE AND MAINTENANCE

IDLER ALIGNMENT — Cont'd

If one section of a belt runs true and another section runs out of line, either the belt is bowed from improper storage or handling or the belt is not properly spliced. If the belt runs out of line consistently at one point in the conveyor, the condition can be attributed to misaligned idlers. Usually the idlers that require adjustment will be located upstream of the point at which the belt runs out of line.

Proper alignment is achieved by loosening the mounting bolts on several idlers on the upstream side and skewing them slightly. When one side of an idler is shifted ahead of the other, the belt shifts to the side which is behind. Retighten the mounting bolts before restarting the conveyor.

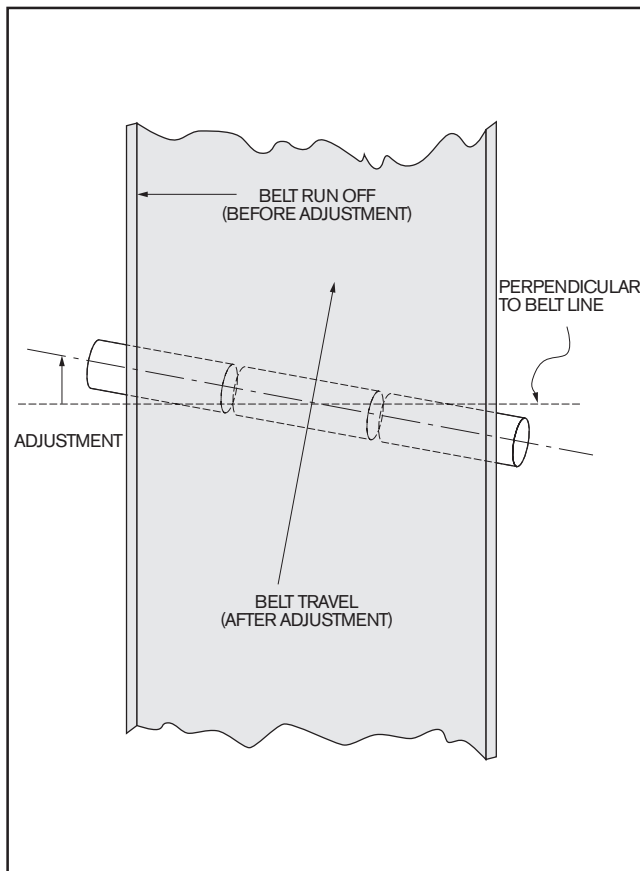

Do not shift idlers on a reversing belt as this will detrain the belt when it travels in the opposite direction.

Once constant central alignment has been achieved on the return and carrying run with an empty belt, the conveyor should be checked while carrying a full load.

LOADING

Start with a light load and gradually work up to the load that the conveyor was designed to handle. Check chutes to see that the material is being directed onto the center of the belt. Off-center loading is harmful to belt, idlers, and shafting. An off-center load will affect belt alignment in that the belt will run off center. An on-center load will maintain belt alignment.

To insure maximum **belt protection** for optimum life and to reduce skirtboard leakage the **impact idlers** should be at least **six inch diameter** and spaced at **one foot intervals**.

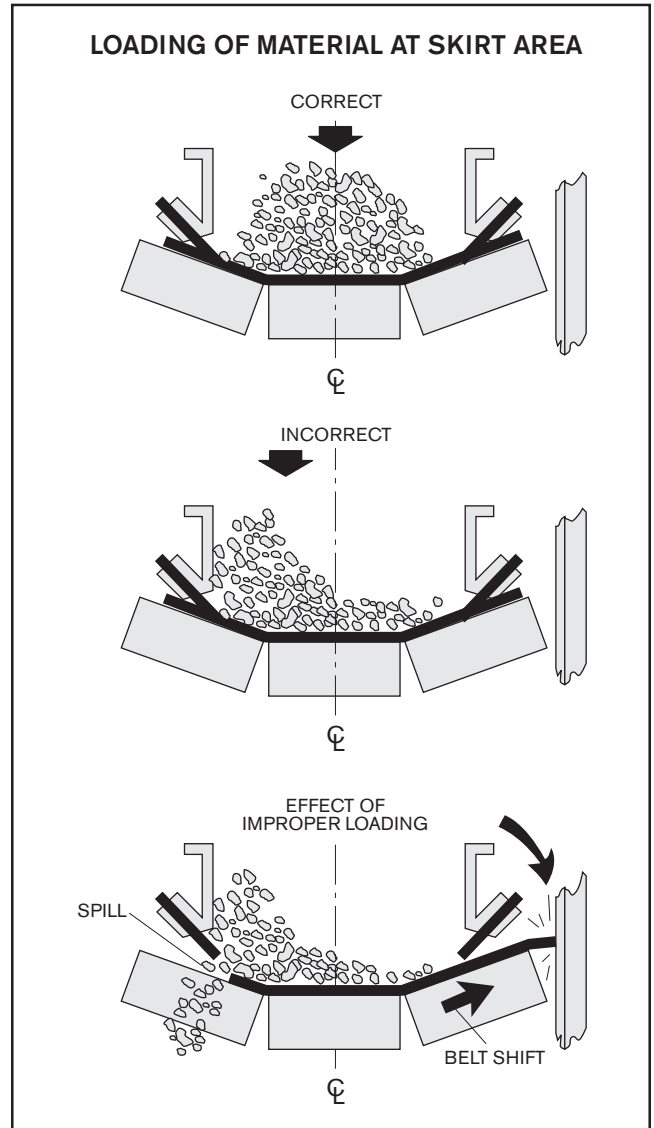

The loading area of a belt conveyor is the critical point. Here the conveyor receives its major abrasion and practically all of its impact. The ideal condition is to have the material pass from chute to belt at the same speed and direction of travel as the belt, with a minimum amount of impact, and to load the belt on center.

The skirts must be adjusted to prevent side spillage of material and to keep the load central on the belt. The maximum distance between skirtboards customarily is two thirds the width of a troughed belt. It is desirable, when possible, to reduce this spacing to one half the width of the troughed belt especially for free flowing materials.

The skirt lengths are designed to stop side spillage. The material should also be at rest on the belt before it reaches the end of the skirt. If the material is still tumbling as it passes the skirt end, the skirts should be lengthened.

TRAINING IDLERS

A properly aligned and centrally loaded belt will track in the center of the idlers without using training idlers. Training idlers are used to compensate for occasional irregular loading, the effects of wind, and other varying conditions.

REX IDLERS

INSTALLATION, CARE AND MAINTENANCE

TROUGHING TRAINING IDLERS

Troughing training idlers are installed along the conveyor length, as required, but not closer than fifty feet from a pulley. Positive arm types are used on belts traveling in one direction only. Actuating shoe types are used on reversing belts and on belts with traveling trippers or stackers.

RETURN TRAINING IDLERS

Return training idlers are installed along the conveyor length, as required, but not closer than fifty feet from a pulley. Positive arm and inclined pivot types are used on belts traveling in one direction only; actuating shoe types are used on reversing belts.

TILTING IDLERS

Tilting the troughing idlers forward (not over 2 degrees) in the direction of belt travel produces an aligning effect. This may be accomplished by placing a tilting block or steel washer under the rear of the idler stand. If the angle of tilt exceeds 2 degrees, excessive wear may occur on the belt and on the idler rolls, since the rolls are rotating on an axis which is not at right angles to the path of belt travel. This method has the advantage over shifting idlers in that it will correct movement on the belt before and after the idler, hence, it is useful for training erratic belts.

Both shifting and tilting idlers are unidirectional adjustments. They are obviously not effective for a reversing belt.

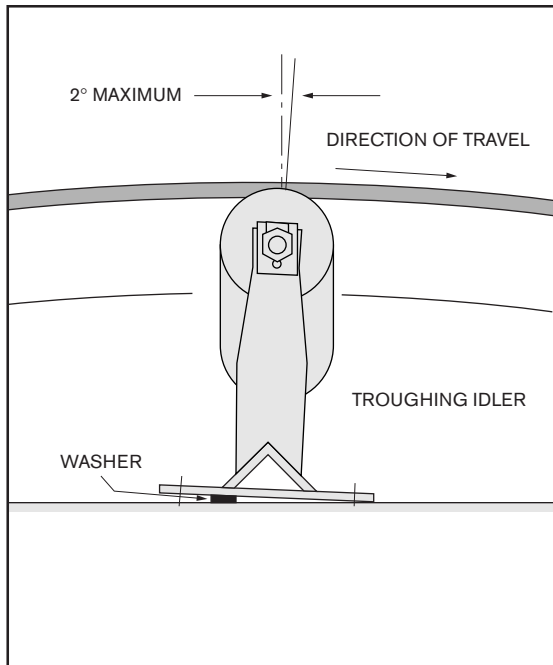

Return idlers cannot be tilted, however, by shifting their axis, they can be used to provide a corrective effect.

This can be done by slightly advancing and raising the alternate ends of the return rolls nearest the tail pulley. This can be done for expediency on a *temporary basis*. If this area is a training problem, a self-aligning return idler should be installed about the 2nd or 3rd idler from the tail pulley.

NOTE

Shifting or tilting of idlers for belt training can only be used for belts traveling in **one direction only**. This remedy cannot be used for **reversing belt** conveyors.

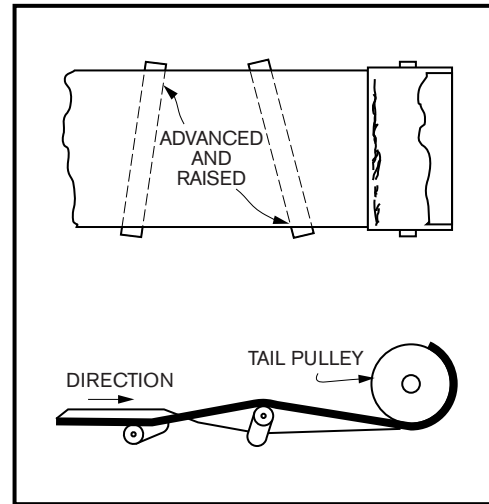

SIDE GUIDE IDLERS

Side guide idlers do not train a belt. They are sometimes used to prevent a belt from running off the pulleys and to prevent the belt from damage caused by contacting the conveyor structure and other objects.

They should be installed so that they do not touch the belt edge when it is running normally. If the belt runs against a side guide idler continually, even though the rolls are free to rotate, belt edge wear can occur.

REX IDLERS

INSTALLATION, CARE AND MAINTENANCE

LUBRICATION

All Rex idlers are prelubricated at the factory and are ready for operation. All external lubrication lines (if added by the customer) should be filled with grease when installed to insure that the idlers will get grease when the lubrication cycle is started.

Under normal conditions, relubrication should be every 4000 to 6000 hours until a clean bead of grease appears around the final opening of each seal.

The lubrication cycle can be lengthened in applications where operating conditions are clean, dry, of moderate temperature and slow speed. The cycle should be shortened in applications where severe dirt, high humidity, elevated temperatures, high speeds, free water, prolonged shutdown, or other extreme conditions are encountered. Periodic inspection during the first few years of operation will provide the best determination of required relubrication frequency.

Rex idlers are greased at the factory with Lithium EP grease with a NLGI #2 consistency having the following characteristics:

1. Lithium soap base
2. Mineral oil
3. Worked penetration 265-295" 77°F
4. Operating range of +225°F to -10°F
5. Bleed rate 3% maximum

It is recommended that an equivalent grease be used. When using any other type of grease, it is imperative that it be compatible with the original grease.

When lubricating idlers, the use of high pressure equipment is not only unnecessary but is actually undesirable unless used with great care. High pressure may cause damage to bearings and seals. It is recommended that a VOLUME TYPE GREASE GUN BE USED: one that delivers an ounce of grease per seven to ten strokes of the lever.

All fittings should be wiped clean before lubricating so as not to introduce dirt into the system.

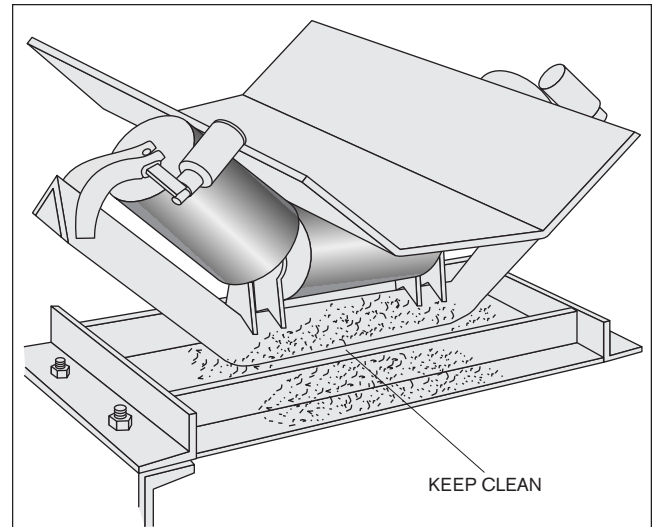
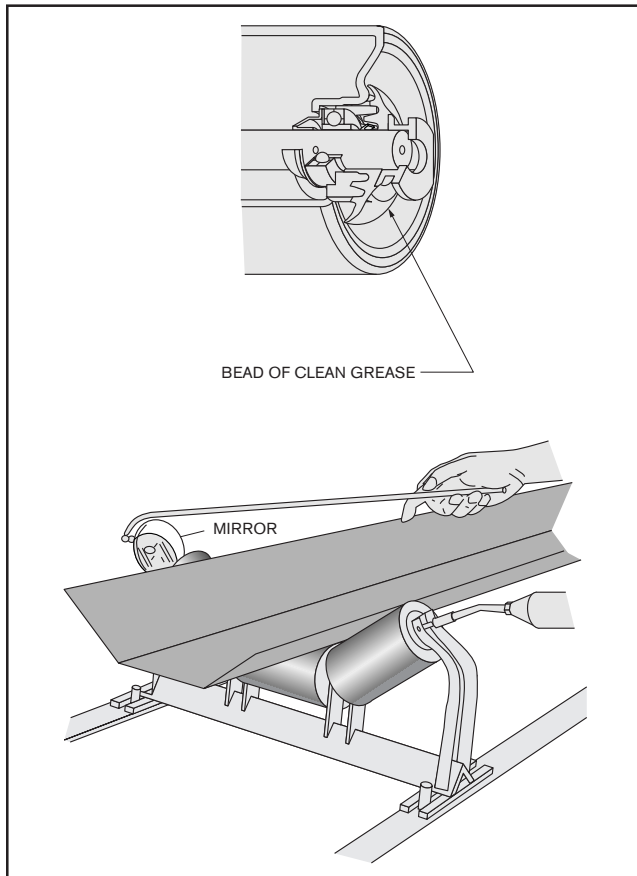

TROUGHING TRAINING IDLER

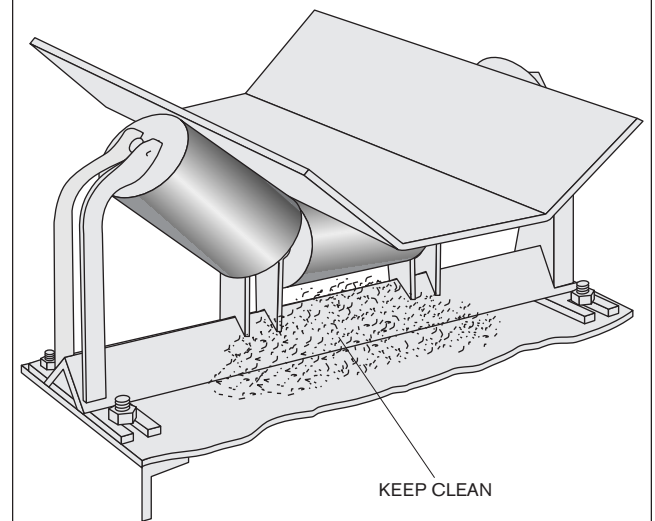

TROUGHING IDLER

INSPECTION AND MAINTENANCE

A scheduled maintenance program, followed faithfully by trained people, can usually help avoid costly interruptions in production and repairs to equipment. Many operators make a cursory check at least once a day to find obvious problems. A more comprehensive inspection is made at periodic intervals.

Inspection should entail the following:

1. Inspect belt for breaks and cuts or for indications that the belt edge is rubbing.
2. The belt should be centered on the idlers.
3. Check loading areas - material should be loaded evenly, and on the center of the belt.
4. Rubber skirts on chutes and skirt plates are adjusted to prevent spillage.
5. Belt cleaners are properly adjusted and working.
6. Rex idlers are designed to be self cleaning. Accumulation of material must not be allowed to prevent idler rolls from rotating or training idlers from pivoting.
7. All idler rolls should be rotating. A stalled roll will cause excessive roll shell and belt wear and should be replaced.

REX IDLERS

INSTALLATION, CARE AND MAINTENANCE Effective Through-Greasing System

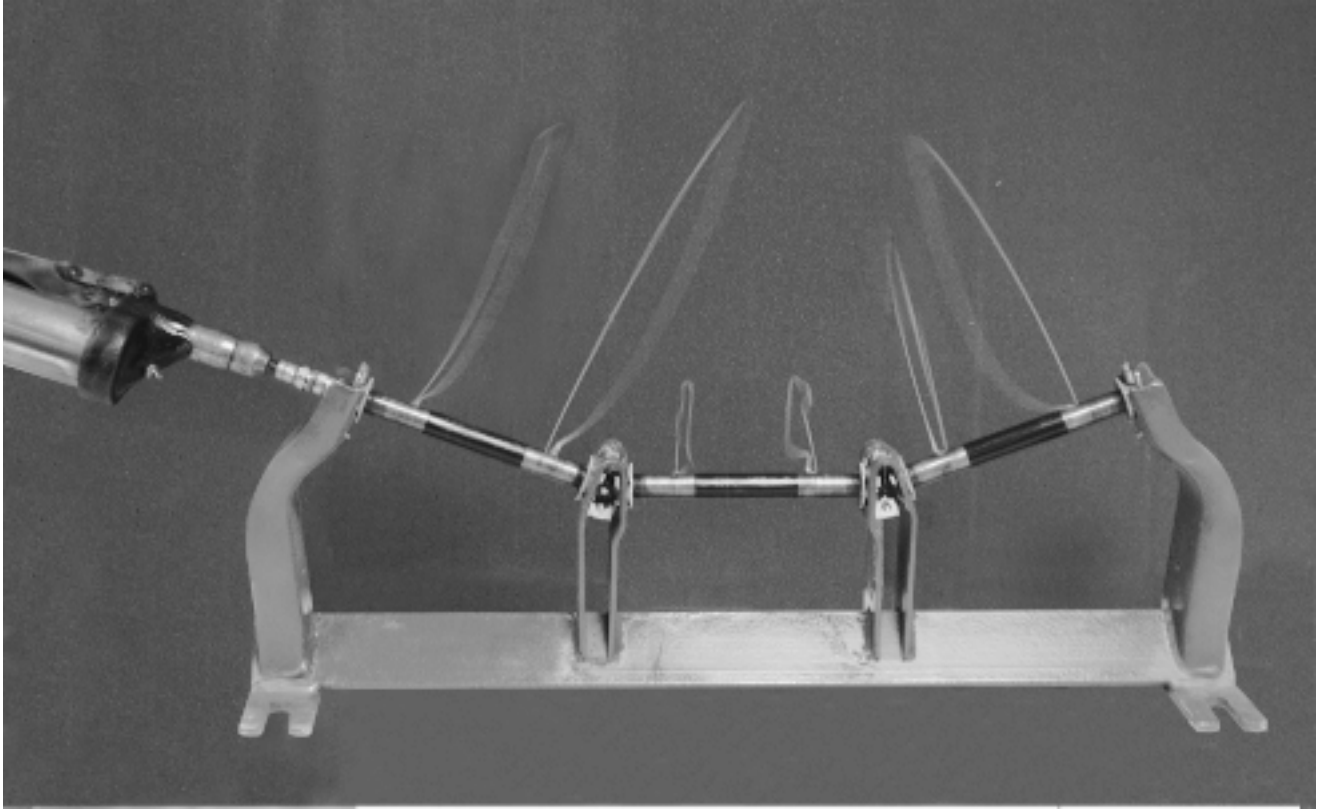

EFFECTIVE THROUGH-GREASING SYSTEM

Rex® patented metered greasing system make use of an engineered grease restrictor in the shafts at each bearing. This develops equalized pressures throughout all roll shafts to provide grease to each bearing cavity without depending on the seals to pressurize the system.

This pressurized system within the shafts allows grease to flow to all bearings without high pressure buildup in the bearing cavities.

This system allows the grease to flow outward through the bearings and seals, purging them of detrimental contaminants that could stop bearing rotation.

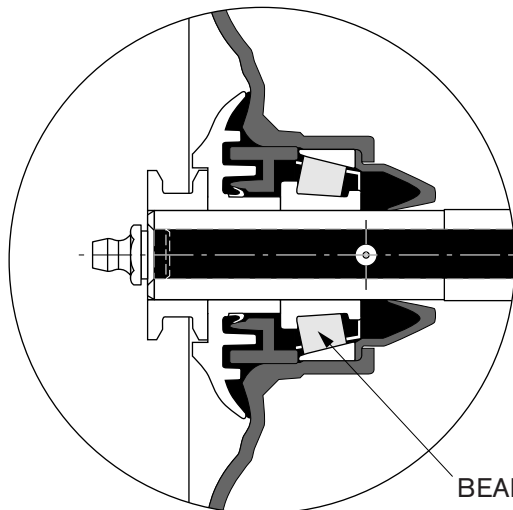

- NON-ROTATING PARTS
- GREASE
- ROTATING PARTS

BEARING

REX IDLERS

BELT CONVEYOR TROUBLE-SHOOTING

Any belt conveyor installation can be subject to a wide variety of problems which may become costly in terms of replacement and plant downtime unless quickly diagnosed and corrected. This guide is intended to point out the majority of belt conveyor problems and to set forth their probable causes and solutions.

Locate the specific problem in the "problem" column below and note the numbers to the right. They represent the most likely causes for the problem, in order of probable occurrence, and how to correct them. The list at the bottom of the page details the causes and solutions by number.

COMMON BELT CONVEYOR PROBLEMS

PROBLEM	CAUSE AND SOLUTION In Order of Probable Occurrence					
	7	15	14	17	21	—
Belt runs off at tail pulley.	7	15	14	17	21	—
Entire belt runs off at all points of the conveyor.	26	17	15	21	4	16
One belt section runs off at all points of the conveyor.	2	11	1	—	—	—
Belt runs off at head pulley.	15	22	21	16	—	—
Belt runs to one side throughout entire length at specified idlers.	15	16	21	—	—	—
Belt slip.	19	7	21	14	22	—
Belt slip on start-up.	19	7	22	10	—	—
Excessive belt stretch.	13	10	21	6	9	8
Belt breaks at or behind fasteners; fasteners tear loose.	2	23	13	22	20	10
Vulcanized splice separation.	13	23	10	20	2	9

PROBLEM	CAUSE AND SOLUTION In Order of Probable Occurrence					
	12	25	17	21	8	5
Excessive wear, including rips, gouges, ruptures and tears.	12	25	17	21	8	5
Excessive bottom cover wear.	21	14	5	19	20	22
Excessive edge wear, broken edges.	26	4	17	8	1	21
Cover swells in spots or streaks.	8	—	—	—	—	—
Belt hardens or cracks.	8	23	22	18	—	—
Covers become checked or brittle.	8	18	—	—	—	—
Longitudinal grooving or cracking of top cover.	27	14	21	12	—	—
Longitudinal grooving or cracking of bottom cover.	14	21	22	—	—	—
Fabric decay, carcass cracks, ruptures, gouges (soft spots inbelt).	12	20	5	10	8	24
Ply separation.	13	23	11	8	3	—

PROBABLE CAUSES AND SOLUTIONS

- Belt bowed** — Avoid telescoping belt rolls or storing them in damp locations. A new belt should straighten out when "broken in" or it must be replaced.
- Belt improperly spliced or wrong fasteners** — Use correct fasteners. Retighten after running for a short while. If improperly spliced, remove belt splice and make new splice. Set up regular inspection schedule.
- Belt speed too fast** — Reduce belt speed.
- Belt strained on one side** — Allow time for new belt to "break in." If belt does not break in properly or is not new, remove strained section and splice in a new piece.
- Breaker strip missing or inadequate** — When service is lost, install belt with proper breaker strip.
- Counterweight too heavy** — Recalculate weight and adjust counterweight accordingly. (If using screw takeups, reduce takeup tension to point of slip, then tighten slightly.)
- Counterweight too light** — Recalculate weight required and adjust counterweight accordingly. (If using screw takeups, increase tension.)
- Damage by abrasives, acid, chemicals, heat, mildew, oil** — Use belt designed for specific condition. For abrasive materials working into cuts and between plies, make spot repairs with cold patch or with Permanent Repair Patch. Seal metal fasteners or replace with vulcanized step splice. Enclose conveyor for protection against rain, snow and sun. Don't over-lubricate idlers.
- Differential speed wrong on dual pulleys** — Make necessary adjustment.
- Drive underbelted** — Recalculate maximum belt tensions and select correct belt. If conveyor is over-extended, consider using two-flight system with transfer point. If carcass is not rigid enough for load, install belt with proper flexibility when service is lost.
- Edge worn or broken** — Repair belt edge. Remove badly worn or out-of-square section and splice in a new piece.
- Excessive impact of material on belt or fasteners** — Use correctly designed chutes and baffles. Make vulcanized splices. Install impact idlers. Where possible, load fines first. Where material is trapped

under skirts, adjust skirtboards to minimum clearance.

- Excessive tension** — Recalculate and adjust tension. Use vulcanized splice within recommended limits.
- Idler rolls not turning** — Correct or replace stalled rolls. Lubricate. Improve maintenance. (Don't over-lubricate.)
- Idlers or pulleys out-of-square with center line of conveyor** — Realign. Install limit switches for greater safety.
- Idlers improperly placed** — Relocate idlers or insert additional idlers spaced to support belt.
- Improper loading, spillage** — Feed should be in direction of belt travel and at belt speed, centered on the belt. Control flow with feeders, chutes and skirtboards.
- Improper storage or handling** — Refer to your belt supplier for storage and handling tips.
- Insufficient traction between belt and pulley** — Increase wrap with snub pulleys. Lag drive pulley. In wet conditions, use grooved lagging. Install correct cleaning devices on belt. Install centrifugal switch for safety.
- Material between belt and pulley** — Use skirtboards properly. Remove accumulation. Improve maintenance.
- Material build-up** — Remove accumulation. Install cleaning devices, scrapers, and inverted "V" decking. Improve housekeeping.
- Pulley lagging worn** — Replace worn pulley lagging. Use grooved lagging for wet conditions.
- Pulleys too small** — Use larger-diameter pulleys.
- Radius of convex vertical curve too small** — Increase radius by vertical realignment of idlers to prevent excessive edge tension.
- Relative loading velocity too high or too low** — Adjust chutes or correct belt speed. Consider use of impact idlers.
- Side loading** — Load in direction of belt travel, in center of conveyor.
- Skirts improperly placed** — Install skirtboards so that they do not rub against belt.

Rex Whisperol® Idlers

Take a closer look.



Quiet. Whisperol® polymeric rollers are quiet! They run considerably quieter than steel rollers with ball bearings because they're made completely of engineering grade polymeric materials. Only the hex shaft is metal.



Resists Corrosion. Whisperol's polymeric construction eliminates rust and corrosion. Only the shaft is metal, and that is available in corrosion resistant stainless steel. Or, it can be nickel plated.

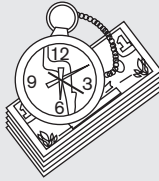

Saves Time and Money. Spring loaded hex shafting makes quick work of Whisperol installation and removal. Whisperol roller lengths come in increments of 1/4" ensuring that any current roller length you have can be matched with a replacement Whisperol.

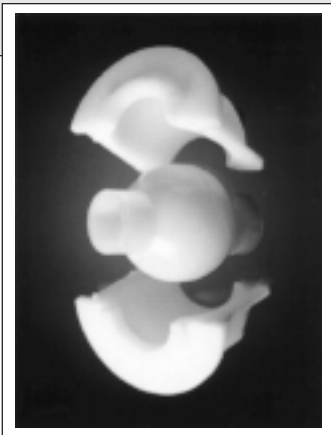

Unique in the roller industry, Whisperol spherical bearings allow for a large amount of misalignment without affecting rolling friction. Low friction, engineering grade polymeric materials give exceptional wear life and create very little sound. This patented bearing makes

Whisperol polymeric rollers the most feature filled product for the price.

Options.

- Nickel plated shafting – corrosion resistance for frequent washdown applications.
- Stainless steel shafting – excellent corrosion resistance against acid and chemical washdowns used in the food and beverage industry.
- Dual drive grooves for a line shaft conveying applications. Not available on the 250 Series with a 7/16" shaft.
- Steel internal sleeves can be inserted inside the polymeric roll shell for greater impact resistance and rigidity. Allows wider "BF" dimensions.

Note: The 250 Series Whisperol rollers use a unique sleeve bearing to provide greater support in heavy duty applications. The same engineering grade polymeric materials are used.

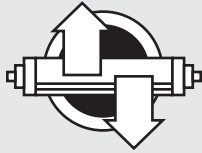

Self-Aligning Bearings. Patented spherical bearing handles misalignment up to 5° and still operates at peak efficiency.



Long Lasting. Durable engineered polymeric materials give excellent performance and a long uninterrupted life. Self-lubricated and self-aligning, Whisperol operates for years without an ounce of attention. You'll forget they're there!

FDA Approved. Whisperol polymeric rollers are made of FDA approved materials. They may be used for packaged product handling in inspected food plants.



Protects Your Products. Whisperol's polymeric roll shell resists build-up of glues, starches and other common packaging contaminants. The smooth, slippery surfaces of the polymeric roll shell don't give contaminants a place to hang on. Plus, they're antistatic, further reducing the chances for build-up to collect on the roll shell.



Lower Maintenance Costs. No lubrication or maintenance is required. What this means to you is Whisperol quietly goes about its business with no attention from your maintenance staff.



Whisperol® rollers will quietly handle any type of packaged product: beverage cases, packaged foods and general unit handling. The polymeric roll shell resists static charges, thereby reducing the attraction of dirt and debris.

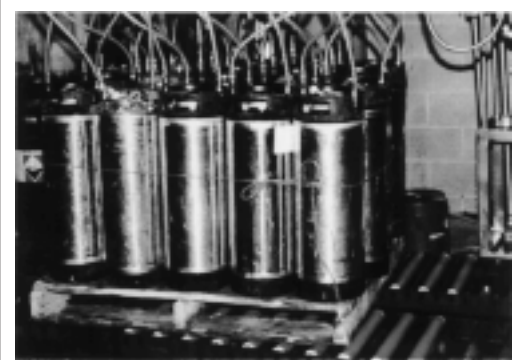

Whisperol® rollers can handle a variety of product configurations and loading ranges. As this photo demonstrates, even heavily loaded wooden pallets may be conveyed. If you need to roll it, Whisperol polymeric rollers can do the job quietly and cleanly.

How to determine load per roller.

Typical roller design will assure that 3 rollers will come in contact with the package at all times. In the figure below, the package leaves roller "A" at the same time it comes in contact with roller "D".

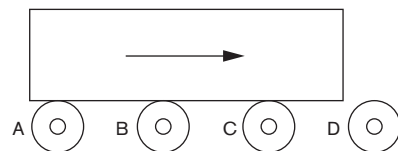

How to calculate roller loading.

1. Verify that the existing roller spacing actually maintains 3 rollers under the package at all times.
2. Divide the package length by 4 to get the proper roller spacing that will assure roller contact at all times.
3. Now divide the package weight by 3 to get the actual load per

roller spacing and load per roller.

In many instances, more than 3 rollers are supporting the package. In these cases, use that quantity of rollers divided into the package weight to determine the load per roller quantity found in Step 3.

REX WHISPEROL® IDLERS

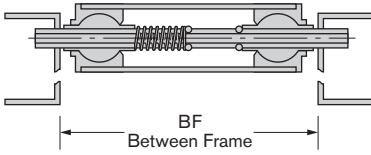

Normal-duty roller conveyors.
(1.9" dia. 7/16" hex shaft)

The 190 Series was designed to deliver superior service, quiet running and low maintenance for a variety of conveyor applications. With a full range of options available, the 190 Series can be adapted to virtually any application.

190 SERIES

Size Ranges • Available in increments of 1/4" from 6" BF to 33" BF
Load Capacity • 40 lbs.
 Requires internal steel sleeve for BF>38"

Whisperol® conveyor roller application data-1.9" dia. roller on 7/16" hex shaft

Belt Speed FPM	Belt Speed FPM	Dynamic Friction for Power Calculations-%					Operating Conditions
		Load/Roller - in Pounds At 75°F ambient temperature*					
		10#	15#	20#	30#	40#	
100	200	4.0%	4.0%	4.0%	4.0%	3.5%	Continuous Service Power or Gravity Conveyor Intermittent Service at stated. Load and Speed up to 60% of the time. Powered Conveyor.
150	300	4.0%	4.0%	4.0%	4.0%	4.0%	
200	400	4.0%	4.0%	4.0%	4.0%	4.0%	
225	450	4.0%	4.0%	4.0%	4.0%	4.0%	
250	500	4.0%	4.0%	4.0%	4.0%	4.0%	
275	550	4.5%	4.0%	4.0%	4.0%	4.0%	
300	600	4.5%	4.0%	4.0%	4.0%	4.0%	

*At 90°F to 100°F Ambient Temperatures, operate these rollers at only 50% of continuous service at a maximum speed of 125 RPM.
 Note: Spring loaded shafts available as standard.

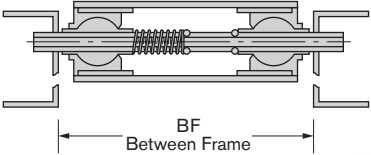

For wider conveyor applications.
(2.25" dia. 7/16" hex shaft)

With its thicker shell, the 225 Series delivers wider load carrying capabilities - up to 54". The spring-loaded shaft simplifies installation.

225 SERIES

Size Ranges • Available in increments of 1/4" from 6" BF to 54" BF
Load Capacity • 40 lbs.
 Requires internal steel sleeve for BF>40"

Whisperol® conveyor roller application data-2.25" dia. roller on 7/16" hex shaft

Belt Speed FPM	Belt Speed FPM	Dynamic Friction for Power Calculations-%					Operating Conditions
		Load/Roller - in Pounds At 75°F ambient temperature*					
		10#	15#	20#	30#	40#	
100	200	4.0%	4.0%	4.0%	4.0%	3.5%	Continuous Service Power or Gravity Conveyor Intermittent Service at stated. Load and Speed up to 60% of the time. Powered Conveyor.
150	300	4.0%	4.0%	4.0%	4.0%	4.0%	
200	400	4.0%	4.0%	4.0%	4.0%	4.0%	
225	450	4.0%	4.0%	4.0%	4.0%	4.0%	
250	500	4.0%	4.0%	4.0%	4.0%	4.0%	
275	550	4.5%	4.0%	4.0%	4.0%	4.0%	
300	600	4.5%	4.0%	4.0%	4.0%	4.0%	

*At 90°F to 100°F Ambient Temperatures, operate these rollers at only 50% of continuous service at a maximum speed of 125 RPM.
 Note: Spring loaded shafts available as standard.

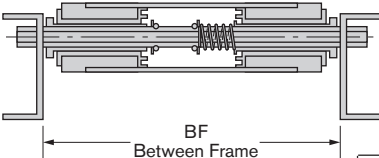

For heavy-duty handling conveyors.
(2.50" dia. 7/16" or 1 1/16" hex shaft)

With 1 1/16" hex shaft and cylindrical bearings, the heavy-duty 250 Series is built to handle loads smoothly and quietly.

250 SERIES

Size Ranges • Available in increments of 1/4" from 10" BF to 63" BF (54" BF with 7/16" hex shaft).
Load Capacity • 250 lbs. with 1 1/16" hex shaft (optional spring-loaded shaft).
 • 40 lbs. with 7/16" hex shaft (spring-loaded shaft standard).

Whisperol® conveyor roller application data-2.50" dia. roller on 1 1/16" hex shaft

Belt Speed FPM	Belt Speed FPM	Dynamic Friction for Power Calculations-%				Operating Conditions
		Load/Roller - in Pounds At 75°F ambient temperature*				
		100#	150#	200#	250#	
50	77	4.0%	4.0%	4.0%	4.0%	Continuous Service Power or Gravity Conveyor Intermittent Service at stated. Load and Speed up to 60% of the time. Powered Conveyor.
75	115	4.0%	4.0%	4.0%	4.0%	
100	155	4.0%	4.0%	4.0%	4.0%	
150	230	4.0%	4.0%	4.0%	4.0%	
200	310	4.0%	4.0%	3.5%	3.5%	

*At 90°F to 100°F Ambient Temperatures, operate these rollers at only 50% of continuous service at a maximum speed of 125 RPM.
 Note: Standard roller shafts are spring loaded shafts construction. Cottered shafts available as option.
 Center support bearings are furnished as standard on rollers above 31" BF.

How to order Whisperol®

1. Measure between frame (BF) dimension (in inches).
2. Select roll diameter: 1.9", 2.25" or 2.5"
3. Specify options:
 - special shaft materials
 - drive grooves
 - internal steel sleeve.
4. Determine quantity (10 pc. Minimum) of rollers needed.

Important dimensions

Dimension	Models	
	190, 225 and 250 (7/16" shaft)	250 (1 1/16" shaft)
A-Shaft Length	BF + 1 1/2"	BF + 2"
B-Bearing to Bearing Length	BF - 1/4"	BF - 1/4"

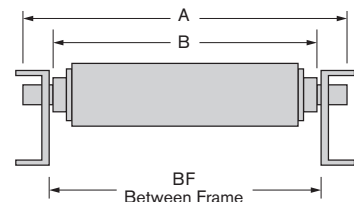

REX FLAT SPRAY NOZZLES

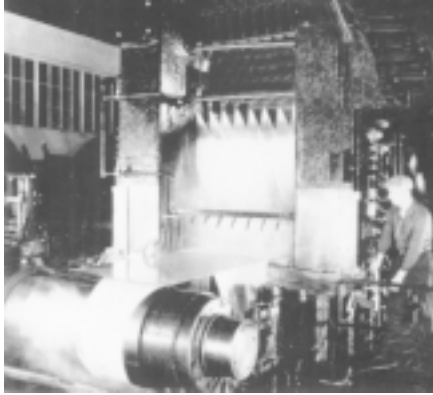

STEEL: Steel sheets are cooled with blades of water from Rex Flat Spray Nozzles.

FOR PRECISION:

- **COOLING**
- **WASHING**
- **CLEANING**
- **DESCALING**



Rock: Efficient use of Rex Flat Spray Nozzles cleans rock with a minimum of water and power.

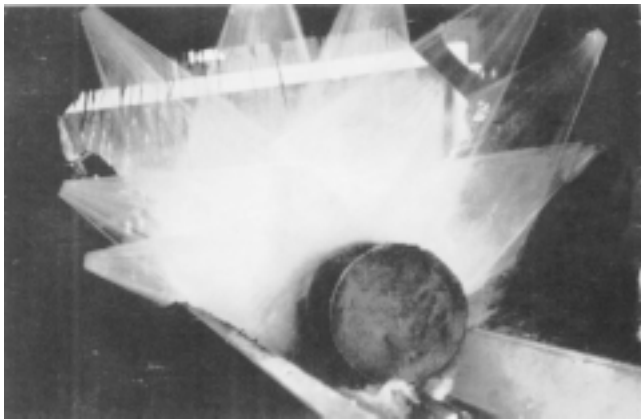

LUMBER: Rex Flat Spray Nozzles remove all saw-destroying grit and dirt from logs.

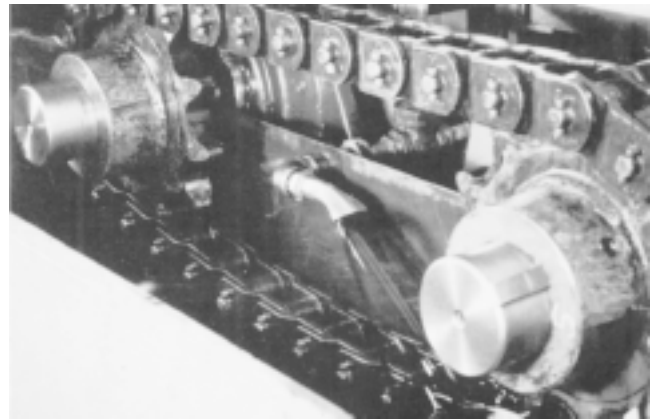

LUBRICATION: High Speed chain is lubricated and cooled with a Rex Flat Spray Nozzle.

Precise Spray Pattern

The wide range of deflectors and venturis offers a choice of liquid patterns from high velocity micro-thin to delicate low velocity at the correct pressure, quantity and angle of impact.

Precision-Controlled Pattern

Guide vanes, designed for a specific application, produce a sharp-edged blade of liquid for uniform cutting or cooling. There is no loss of liquid in side splatter. Can cut liquid usage as much as 80%.

Precision-Controlled Impact

The perfectly flat, polished deflector makes sure that every drop of liquid works hard — that every drop is kept in line to form an efficient micro-thin water blade. The venturi throat is uniformly tapered to eliminate turbulence and guide every drop of liquid onto the deflector with maximum force.

Performance Inspected — Each Rex Flat Spray Nozzle is hand-finished. They are not released for delivery until final inspection — under actual operating conditions — shows the blade pattern to be perfect. This is your guarantee of performance.

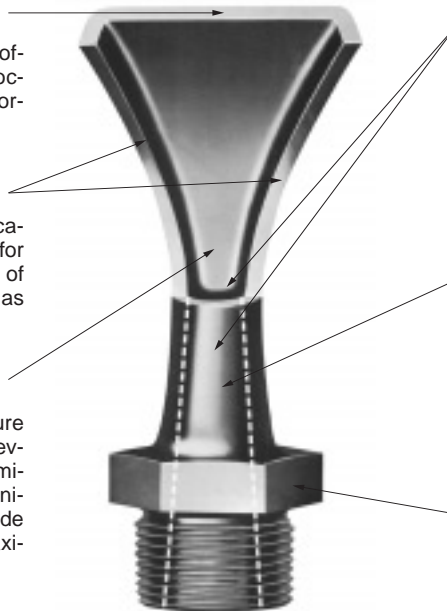

Dependable Performance

The circular orifice and tapered throat keep the Rex Flat Spray Nozzles working under conditions that would quickly plug ordinary slotted openings. The Rexnord design provides a maximum-size opening to allow particles used for cleaning to pass through easily, to assure long clog-free operation.

Long Operating Life

Rex Flat Spray Nozzles are designed for various applications and pressures. Suitable blade construction materials and proper proportioning of the shank and deflector give rugged durability under the working pressures for which each was designed. There is a Rex Flat Spray Nozzle for any working pressure from 20 to 1500 p.s.i.

Simple, Quick, Permanent Installation

One-piece construction, with standard pipe threads and standard hex for wrenches, means simple, easy installation. No adjustments are required at any time during or after installation.

REX FLAT SPRAY NOZZLES

SELECTION PROCEDURE

THE AVAILABLE WATER PRESSURE (PSI) MUST BE KNOWN.

- From the typical application tables (pages 95 — 96), select an application similar to the one under consideration.
- Estimate the distance from the Spray Nozzle to the line of impingement and enter selected application table.
- Select orifice size based on available pressure. Use smallest orifice for minimum water usage. Use largest orifice for highest impact force and greatest water discharge.
- After determining the orifice size, read down to the bottom of the chart and find the patterns available and the pipe thread size.
- Using Table 1, select the proper Material Code that is compatible with the washing solution being used.
- Check Table 2 to determine which of the patterns from Step 4 are available in the material selection from Step 5.
- Having determined the pattern, turn to Table 13, page 97, to determine spray width.
- To determine quantity required, divide the total coverage needed by the spray width.
- To order, list quantity, pattern number, material code, and orifice size.

NOTE: To determine discharge rate in gallons per minute (GPM) for any orifice size and pressure, see page 98.

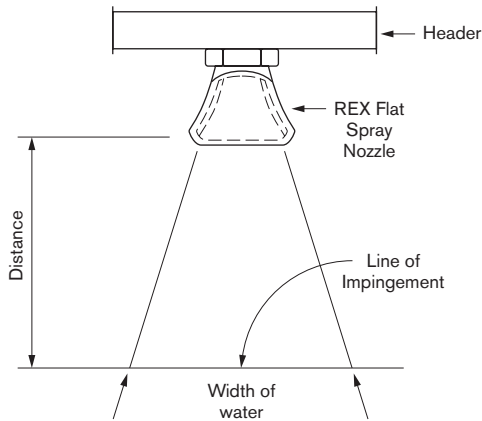

**Table 1
Nozzle Material Selection Code**

Liquid Solution	Pressure Range in Pounds per Square Inch (p.s.i.)						
	0-50	51-100	101-200	201-300	301-600	601-1000	1001-1500
1. Clear Water	B or MB	B or MB	BH	BH	AH	AH	AAH
2. Water with some Silt	B or MB	BH	AH	AH	AAH	AAH	AAH
3. Water with some Sand	BH	AH	AH	AH	AAH	AAH	
4. Water with Detergent	S or Z	S or Z	SH or ZH	AAH	AAH		
5. Mildly Acid Solution	B or MB	B or MB	AAH	AAH			
6. Harsh Acid Solution	SS	SS	AAH				

Read step 5 here

Example

Cooling Steel in Mill
(see page 95, Table 8)

16"
300 PSI
16.4 GPM
12 Orifice

70488A or 70488B or 70873A.
3/8" Pipe Thread

Clear Water
Code BH.

Aluminum Bronze is available for patterns
70488A & 70488B. Use 70488B (See footnote ★)

12"
 $\frac{148}{12} = 13$

13 pcs. 70488B — BH-12

NOTE: Use smallest orifice size as impact force not required for this application.

**Table 2
Pattern Selection**

Mat'l. Code ▲	Material Description	Pipe Thread Size			
		3/8"		3/4"	
		Orifice Number Range			
		6-16	16-20	22-28	32-36
Pattern Number ★					
A	416 Stainless Steel	70488B		70608A 74493A	On Appl.
AH	416 Stainless Steel - Heat Treated	70488B		70608A	On Appl.
AAH	440C Stainless Steel - Heat Treated	70488A	70608B		
B	Aluminum Bronze	70488A 70488B	70608B	70608A 70229A 73889A	
BH	Aluminum Bronze - Heat Treated	70488A 70488B	70608B	70608A	
MB	Manganese Bronze	70873A	70608B	70608A	70494A
MBP	Mn. Br. - Polished	70873A	70608B	70608A	
S	8617 Steel	70488B			
SH	8617 St. - Heat Treated	70488B			
SS	303 Stainless Steel	70488A 70488B			
SSP	303 S. S. - Polished	70488B			
Z	Cast Iron		70608B	70608A 74493A	70494A
ZH	Cast Iron - Heat Treated		70608B	70608A 74493A	70494A

Read step 6 here

- ▲ Suffix letter "P" indicates material with polished finish only.
- Suffix letter "H" indicates hardened material with polished finish.
- ★ If more than one pattern is shown, consider the following: The pattern with the lesser angle of discharge will give the greater impact. The pattern with the wider deflector blade will produce a wider spray pattern but less impact. (See page 97).

Note: Dimensions subject to change. Certified dimensions of ordered material furnished on request.

REX FLAT SPRAY NOZZLES

TYPICAL APPLICATION TABLES

Table 3
Log Washing
Gallons Per Minute

Distance Inches	PSI	Orifice		
		28	32	36
16	40		42.5	53.9
	50	36.4	47.6	60.2
	60	39.9	52.1	66.0
	70	44.0	56.1	71.1
	80	46.1	60.2	76.2
	100	51.5	67.7	85.1
	125	57.6	75.2	
24	70			71.1
	80			76.2
	90			80.7
	100			85.1
	125			95.2
150			104.3	
Pattern	70229A 70608A&B 73889A 74493A	70494A		
PipeThread	¾"	1"		

Table 4
Washing Hard Vegetables
Gallons Per Minute

Distance Inches	PSI	Orifice							
		6	7	8	9	10	11	12	
16	40	1.5							
	24	30	1.3	1.8					
36	40	1.5	2.0						
	50	1.7							
	20		1.9	2.4	2.9				
48	30			2.3	2.9	3.6			
	40			2.7	3.4	4.2			
	50			3.0			2.9	3.6	4.2
	60						3.6	4.4	5.2
Pattern	70488A—70488B—70873A								
Pipe Thread	¾"								

Table 5
Can and Bottle Washing
Gallons Per Minute

Distance Inches	PSI	Orifice			
		6	7	8	9
12	60	1.8			
	70	1.9			
	80	2.1			
	90	2.3			
16	40				3.4
	50				3.8
	60			3.0	4.1
	70			3.3	4.4
	80			3.8	
Pattern	70488A—70488B—70873A				
Pipe Thread	¾"				

Table 6
Descaling Steel
Gallons Per Minute

Distance Inches	PSI	Orifice			
		6	7	8	9
12	400				10.6
	450				11.3
	500				11.9
	600		7.9	9.4	13.0
	700		8.5	11.1	14.1
	800	6.7	9.1	11.9	15.1
	900	7.1	9.7	12.6	
	1200	8.2	10.2		
Pattern	70488A—70488B—70873A				
Pipe Thread	¾"				

Table 7
Washing Felts and Paper —GPM

Distance Inches	PSI	Orifice									
		6	7	8	9	10	11	12	14	16	18
8	40	1.5									
	50	1.7									
12	30				2.9						
	40			2.7	3.4						
	50		2.3	3.0							
	60	1.8	2.5								
	70	2.0									
16	30						4.4				
	40						5.0				
	50			3.0	3.8	4.2					
	70		2.5	3.3							
24	30							7.1			
	40							8.1			
	50				3.8	4.6	5.0	6.0	7.1		
	70				4.1	5.1	5.6	6.7	8.1	9.2	11.7
36	30								8.1	9.2	11.7
	40								9.1	10.6	
	50								7.3		
	60										
Pattern	70488A—70488B—70873A					70229A—70608A&B 73889A—74493A					
PipeThread	¾"					¾"					

Table 8
Cooling Steel in Mill — GPM

Distance Inches	PSI	Orifice							
		9	10	11	12	14	16	18	
12	150				11.6				
	175				12.5				
	200	7.5	9.3	10.5	13.4				
	250	8.4	10.4	12.6	15.0				
	300	9.2	11.4	13.8	16.4				
	350	10.0	12.3	14.9	17.7				
	400	10.6	13.1	15.9	18.9				
	450	11.3	13.9						
	500	11.9							
	16	175							28.2
200								30.1	
250							18.2	23.8	33.7
300					16.4	22.3	29.1	36.9	
350					17.7	24.1	31.5		
400				18.9	25.8				
450				20.1					
500				21.2					
Pattern	70488A—70488B—70673A							70229A 70608A&B 73889A 74493A	
PipeThread	¾"							¾"	

Read step 1 here

Read step 3 here

Read step 2 here

Read step 4 here

Read step 4 here

Note: Dimensions subject to change. Certified dimensions of ordered material furnished on request.

REX FLAT SPRAY NOZZLES

TYPICAL APPLICATION TABLES

Table 9
Washing Soft Vegetables — GPM

Distance Inches	PSI	Orifice							
		6	7	8	9	10	11	12	
16	40	1.5							
	50	1.7							
24	30		1.8						
	40	1.5	2.0						
	50	1.7							
36	20			1.9	2.4	2.9			
	30			2.3	2.9	3.6			
	40			2.7	3.4	4.2			
	50			3.0	3.8	4.6			
48	20						3.6	4.2	
	30						4.4	5.2	
	40						5.0	6.0	
	50						5.6	6.7	
	60						6.2		
Pattern	70488A— 70488B — 70873A								
Pipe Thread	3/8"								

Table 11
Meat Cleaning — GPM

Distance Inches	PSI	Orifice									
		6	7	8	9	10	11	12	14		
12	110		3.3								
	125		3.6								
	150	2.9									
	175	3.1									
16	100			4.2	5.3						
	125			4.7	5.9						
	150			5.1							
24	100					6.6	7.9				
	125					7.3					
36	80										11.5
	100										12.9
Pattern	70488A — 70873A										
Pipe Thread	3/8"										

Table 10
Washing Ore & Gravel — GPM

Distance Inches	PSI	Orifice									
		14	16	18	20	22	24	28	32	36	
12	30			11.7	14.4						
	40		10.6	13.5	16.6						
	50	9.1	11.9	15.5	18.6						
	60	10.0	13.0	16.5	20.4						
	70	10.7	14.0	18.2	21.9						
	80	11.5	15.0	19.0							
	90	12.2	15.9								
	100	12.9									
	16	30				17.4	20.7				
		40			13.5	16.6	20.1	23.9			
50				15.1	18.6	22.5	26.8				
60				16.5	20.4	24.6	29.3				
70				18.2	21.9	27.5	31.6				
80				19.0	23.5						
90				20.4							
24	30						28.2	36.8			
	40						23.9	32.6	42.5		
	50					22.5	26.8	36.4	47.6		
	60					24.6	29.3	39.9			
	80					27.5	31.6				
36	30							42.5	53.9	46.0	
	40							47.6	60.2	53.9	
	50							52.1	66.0	60.2	
	70							56.1	71.1	71.1	
	80							60.2			
Pattern	70488A&B 73889A		70229A — 70608A&B 73889A — 74493A					70494A			
Pipe Thread	3/8"		3/4"					1"			

Table 12
Washing Vehicles & Scum Removal — GPM

Distance Inches	PSI	Orifice															
		6	7	8	9	10	11	12	14	16	18	20	22	24	28		
8	40					4.2											
	50					4.6											
	60				3.3	4.1	5.1										
	70			2.7	3.5	4.5											
	80			2.9	3.8												
	90			3.1													
	12	50					5.1	5.6	6.7								
60						6.2	7.3	7.9									
70					4.5	5.5	6.7	7.9									
80					4.8	5.9	7.1										
90					5.1	6.3											
100					5.3												
16	40																
	50											11.9	15.1				
	60										10.0	13.0	13.5				
	70									7.9	10.7						
	90									8.5	9.0						
24	40												11.9	15.1	16.6		
	50												11.9	15.1	18.6		
	60										10.0	13.0	16.5				
	80										10.7	14.0					
36	30																
	40																
	50																
	60																
	70															23.9	
	80														26.8	28.2	
														16.5	18.6	22.5	26.8
														17.8	21.9	24.6	28.2
Pattern	70488A — 70488B — 70873A										73889A — 74493A 73889A — 74493A						
Pipe Thread	3/8"										3/4"						

Note: Dimensions subject to change. Certified dimensions of ordered material furnished on request.

REX FLAT SPRAY NOZZLES

SPRAY PATTERN WIDTHS (Table 13)

Width of Water Spray (Inches) at Line of Impingement at 60 P.S.I.★

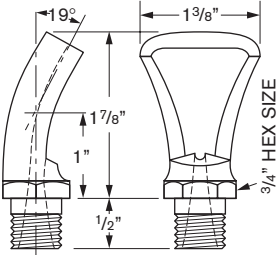
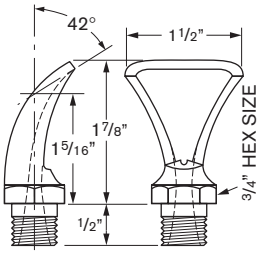
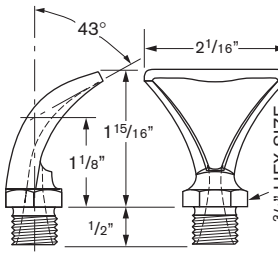
3/8" Pipe Thread	Pattern No. 70488A Approx. Shipping Wt.: 3 oz.		Pattern No. 70488B Approx. Shipping Wt.: 4 oz.		Pattern No. 70873A Approx. Shipping Wt.: 4 oz.																				
																									
	Orifice Sizes in 64th Inches		Orifice Sizes in 64th Inches		Orifice Sizes in 64th Inches																				
Distance from Point of Discharge to Point of Impingement	6	7	8	9	10	11	12	14	16	6	7	8	9	10	11	12	14	16	9	10	11	12	14	16	
4	3	3	3	3	3	3	4	4	4	3	3	3	3	4	4	4	4	4	4	5	5	6	6	6	7
8	4	4	4	4	5	5	6	7	7	5	5	5	6	6	6	6	7	7	8	8	9	10	10	11	12
12	6	6	7	8	8	9	9	10	11	6	7	7	8	8	8	9	10	11	12	12	13	14	15	16	18
16	8	8	9	10	10	11	11	13	14	8	9	9	10	10	11	12	13	14	16	16	17	18	19	21	23
20	9	10	11	12	13	14	14	16	17	10	10	11	12	12	13	14	15	17	20	20	21	22	23	26	28
24	11	12	13	14	15	16	16	18	20	11	12	13	14	15	16	17	18	20	24	24	25	27	28	31	34
32	14	16	17	19	20	21	21	24	26	14	16	16	18	19	20	22	24	26	30	30	32	35	36	40	45
40	18	19	21	24	24	26	26	30	32	18	19	20	22	22	26	27	29	32	38	38	40	44	45	50	56
48	21	23	25	28	29	31	32	36	39	21	23	24	27	28	30	32	35	38	45	45	48	52	54	60	65

Read step 7 here

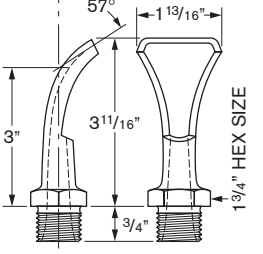
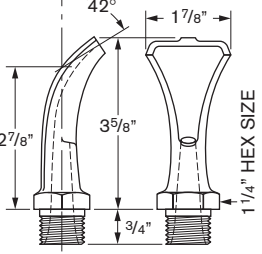
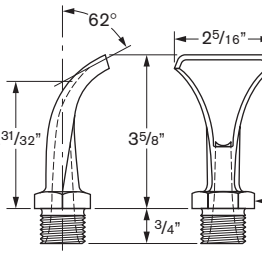
3/4" Pipe Thread	Pattern No. 70229A Approx. Shipping Wt.: 7 oz.		Pattern No. 70608A & 70608B Approx. Shipping Wt.: 8.5 oz.		Pattern No. 73889A & 74493A Approx. Shipping Wt.: 8.5 oz.			
								
	Orifice Sizes in 64th Inches		Orifice Sizes in 64th Inches		Orifice Sizes in 64th Inches			
Distance from Point of Discharge to Point of Impingement	22		70608B		70608A			
			16	20	22	24	28	22
4		5	4	4	5	5	6	7
8		8	6	8	9	9	10	11
12		12	8	11	13	13	14	15
16		15	10	14	16	17	18	19
20		18	12	17	20	21	22	24
24		22	15	21	24	25	26	28
32		28	19	27	31	32	34	36
40		35	24	33	38	40	43	44
48		42	29	39	44	46	51	53

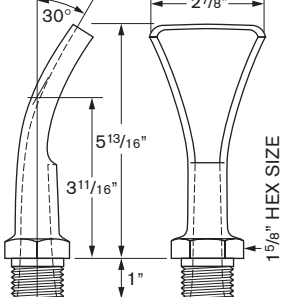
1" Pipe Thread	Pattern No. 7049A Approx. Shipping Wt.: 24 oz.	
		
	Distance from Point of Discharge to Point of Impingement	Orifice Size in 64th Inches
	36	
4	8	
8	13	
12	18	
16	23	
20	28	
24	33	
32	43	
40	52	
48	62	

★ Spray width will vary slightly at other pressures. However, use widths listed for all pressures. For other liquids, consult Rexnord.

Note: Dimensions subject to change. Certified dimensions of ordered material furnished on request.

REX FLAT SPRAY NOZZLES

HOW TO ORDER

1. Number of units. 2. List Pattern No. — Material Code — Orifice Size

Pattern Numbers and Orifice Sizes

Pipe Thread	Pattern Number †	Orifice Size No.													Pipe Thread	Pattern Number †	Orifice Size No.						
		6	7	8	9	10	11	12	13	14	15	16	18	20			22	24	28	36			
		Orifice Diam. In.															Orifice Diam. In.						
		3/32	7/64	1/8	9/64	5/32	11/64	3/16	13/64	7/32	15/64	1/4	9/32	5/16			11/32	3/8	7/16	9/16			
3/8	70488A-AAH	■	□	□	□	□	□	□	■	□	□	□	□	□	□	□	□	3/4	70229A-B	■	□	□	□
3/8	70488A-B	■	■	■	■	■	■	■	■	■	■	■	■	■	■	■	■	3/4	70608A-A	□	□	□	□
3/8	70488A-BH	■	■	□	□	□	□	□	□	□	□	□	□	□	□	□	□	3/4	70608A-AH	□	□	□	□
3/8	70488A-SS	□	□	□	□	□	□	□	□	□	□	□	□	□	□	□	□	3/4	70608A-B	□	□	□	□
3/8	70488B-A	■	□	■	□	□	□	□	■	□	□	□	■	□	□	□	□	3/4	70608A-BH	□	□	□	□
3/8	70488B-AH	□	□	□	□	□	□	□	□	□	□	□	□	□	□	□	□	3/4	70608A-MB	■	□	□	□
3/8	70488B-B	■	■	■	■	■	■	■	■	■	■	■	■	■	■	■	■	3/4	70608A-MBP	□	□	□	□
3/8	70488B-BH	□	□	■	□	□	□	□	□	□	□	□	□	□	□	□	□	3/4	70608A-Z	■	□	□	□
3/8	70488B-S	■	■	■	■	■	■	■	■	■	■	■	■	■	■	■	■	3/4	70608A-ZH	□	□	□	□
3/8	70488B-SH	□	□	□	□	□	□	□	□	□	□	□	□	□	□	□	□	3/4					
3/8	70488B-SS	■	■	■	□	□	□	□	■	□	□	□	□	□	□	□	□	3/4	73889A-B	■	□	□	□
3/8	70488B-SSP	□	□	□	□	□	□	□	□	□	□	□	□	□	□	□	□	3/4	73889A-BH	□	□	□	□
3/8	70873A-MB				■	□	□	■	□	□	□	□	■	□	□	□	□	3/4	74493A-A	□	□	□	□
3/8	70873A-MBP				□	□	□	□	□	□	□	□	□	□	□	□	□	3/4	74493A-AH	□	□	□	□
																		3/4	74493A-Z	■	□	□	□
																		3/4	74493A-ZH	□	□	□	□
3/4	70608B-AAH												□	□	□	□	□	1	70494A-AH				□
3/4	70608B-B												□	□	□	□	□	1	70494A-MB				□
3/4	70608B-BH												□	□	□	□	□	1	70494A-MBP				■
3/4	70608B-MB												■	□	□	□	□	1	70494A-Z				■
3/4	70608B-MBP												□	□	□	□	□	1	70494A-ZH				□
3/4	70608B-Z												□	□	□	□	□	1					
3/4	70608B-ZH												□	□	□	□	□	1					

† See Table 2 for Material Code (Page 94).

■ Stock Size.

□ Order Size — Ten Piece Minimum Quantity.

Discharge Rates in GPM (By Orifice Number)

PSI	6	7	8	9	10	11	12	14	16	18	20	22	24	28	32	36
15	.9	1.2	1.6	2.1	2.5	3.1	3.7	5.0	6.5	8.2	10.2	12.3	14.7	19.9	26.1	33.0
20	1.1	1.4	1.9	2.4	2.9	3.6	4.2	5.8	7.5	9.5	11.8	14.2	16.9	23.0	30.1	38.1
30	1.3	1.8	2.3	2.9	3.6	4.4	5.2	7.1	9.2	11.7	14.4	17.4	20.7	28.2	36.8	46.6
40	1.5	2.0	2.7	3.4	4.2	5.0	6.0	8.1	10.6	13.5	16.6	20.1	23.9	32.6	42.5	53.9
50	1.7	2.3	3.0	3.8	4.6	5.6	6.7	9.1	11.9	15.1	18.6	22.5	26.8	36.4	47.6	60.2
60	1.8	2.5	3.3	4.1	5.1	6.2	7.3	10.0	13.0	16.5	20.4	24.6	29.3	39.9	52.1	66.0
80	2.1	2.9	3.8	4.8	5.9	7.1	8.5	11.5	15.0	19.0	23.5	28.4	33.8	46.1	60.2	76.2
100	2.4	3.2	4.2	5.3	6.6	7.9	9.5	12.9	16.8	21.3	26.3	31.8	37.8	51.5	67.3	85.1
125	2.6	3.6	4.7	5.9	7.3	8.9	10.6	14.4	18.8	23.8	29.4	35.6	42.3	57.6	75.2	95.2
150	2.9	3.9	5.1	6.5	8.0	9.7	11.6	15.8	20.6	26.1	32.2	38.9	46.3	63.1	82.4	104.3
175	3.1	4.3	5.6	7.0	8.7	10.5	12.5	17.0	22.2	28.2	34.8	42.1	50.1	68.1	89.0	112.6
200	3.3	4.6	5.9	7.5	9.3	11.2	13.4	18.2	23.8	30.1	37.2	45.0	53.5	72.8	95.1	120.4
250	3.7	5.1	6.6	8.4	10.4	12.6	15.0	20.4	26.6	33.7	41.6	50.3	59.8	81.4	106.4	134.6
300	4.1	5.6	7.3	9.2	11.4	13.8	16.4	22.3	29.1	36.9	45.5	55.1	65.5	89.2	116.5	147.5
350	4.4	6.0	7.9	10.0	12.3	14.9	17.7	24.1	31.5	39.8	49.2	59.5	70.8	96.4	125.9	159.3
400	4.7	6.4	8.4	10.6	13.1	15.9	18.9	25.8	33.6	42.6	52.6	63.6	75.7	103.0	134.6	170.3
450	5.0	6.8	8.9	11.3	13.9	16.9	20.1	27.3	35.7	45.2	55.7	67.5	80.3	109.3	142.7	180.6
500	5.3	7.2	9.4	11.9	14.7	17.8	21.2	28.8	37.6	47.6	58.8	71.1	84.6	115.2	150.4	190.4
550	5.5	7.5	9.9	12.5	15.4	18.6	22.2	30.2	39.4	49.9	61.6					
600	5.8	7.9	10.3	13.0	16.1	19.5	23.2	31.5	41.2	52.1	64.4					
650	6.0	8.2	10.7	13.6	16.7	20.3	24.1	32.8	42.9	54.3	67.0					
700	6.3	8.5	11.1	14.1	17.4	21.0	25.0	34.1	44.5	56.3	69.6					
750	6.5	8.8	11.5	14.6	18.0	21.8	25.9	35.3	46.1	58.3	72.0					
800	6.7	9.1	11.9	15.1	18.6	22.5	26.8	36.4	47.6	60.2	74.3					
850	6.9	9.4	12.3	15.5	19.2	23.2	27.6	37.5	49.0	62.1	76.6					
900	7.1	9.7	12.6	16.0	19.7	23.8	28.4	38.6	50.5	63.9	78.8					
950	7.3	9.9	13.0	16.4	20.2	24.5	29.2	39.7	51.8	65.6	81.0					
1000	7.5	10.2	13.3	16.8	20.8	25.1	29.9	40.7	53.2	67.3	83.1					
1100	7.8	10.7	13.9	17.6	21.8	26.4	31.4									
1200	8.2	11.2	14.6	18.4	22.8	27.5	32.8									
1300	8.5	11.6	15.2	19.2	23.7	28.7	34.1									
1400	8.8	12.0	15.7	19.9	24.6	29.7	35.4									
1500	9.2	12.5	16.3	20.6	25.4	30.8	36.6									

Note: Dimensions subject to change. Certified dimensions of ordered material furnished on request.