

Link-Belt® Ultr-O-Life™ O-Ring Roller Chain

Superior Sealing and Self-Lubrication Extend Chain Life for Savings in Maintenance and Greater Productivity

No doubt you've seen it before: an application that quickly zaps the life out of conventional roller chains. It's common in applications where relubrication borders on the impossible; or in situations where the chain environment is full of contaminants, requiring frequent and costly labor-intensive maintenance. So for extraordinary applications such as these, Rexnord recommends an extraordinary chain – the Ultr-O-Life™ O-Ring Roller Chain, specially engineered for demanding applications.

O-RING SEALS THE LUBRICATION BETWEEN THE PINS AND BUSHING

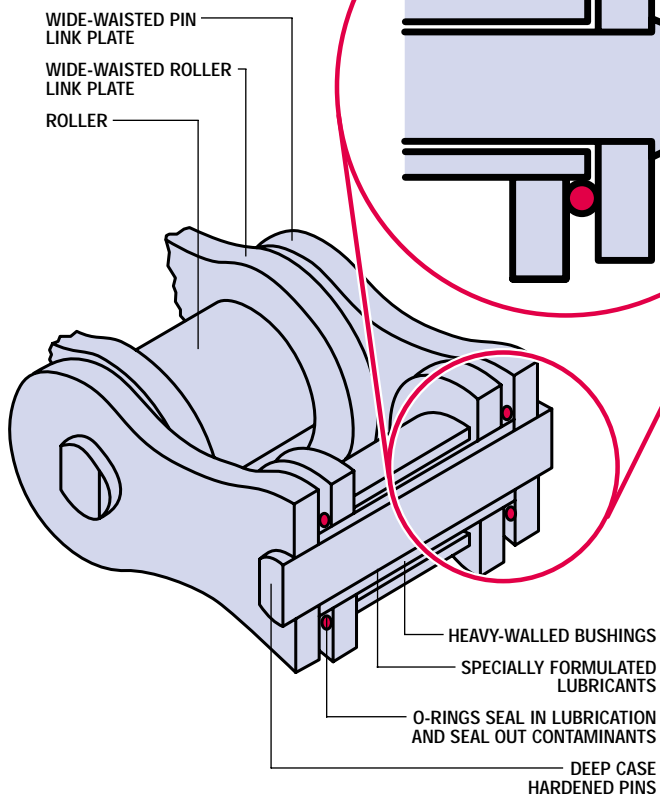

Link-Belt® Ultr-O-Life™ Chain Lasts More Than Three Times Longer Than Standard Roller Chain

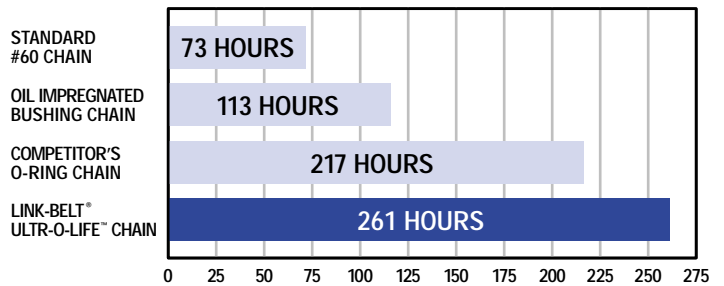

Up to 10 Times More Wear Life than Standard Roller Chain

As the name implies, the Ultr-O-Life™ O-Ring Roller Chain from Rexnord features specifically designed O-rings in each link. These rings seal in a specially formulated lubricant, virtually eliminating the need for relubrication. Plus the O-rings seal out dirt, moisture, and other contaminants, protecting internal pins and bushings, and offering the ultimate protection against accelerated wear.

The result is a virtually maintenance-free chain that lasts up to three times longer than conventional roller chain in severe duty applications, and up to ten times longer in less demanding applications.

The Right Choice for a Wide Range of Demanding Applications

The Ultr-O-Life's™ superior sealing and self-lubricating properties are ideally suited for many industrial applications. It's an excellent choice for food and paper applications where ordinary lubricants and lubrication procedures pose an unacceptable contamination risk or equipment wash-down procedures prohibit lubrication effectiveness. In fact, wherever moisture or abrasives are present, the Ultr-O-Life™ O-Ring Roller Chain is a superior choice.

The Ultr-O-Life™ O-Ring Roller Chain seals in lubrication and seals out contaminants. So use the Ultr-O-Life™ O-Ring Roller Chain wherever dirt, mud, moisture or other destructive contaminants penetrate ordinary lubricants to damage pins and bushings. Plus, Ultr-O-Life™ O-ring seals have been specially designed to trap pre-lube in the joint. That makes the Ultr-O-Life™ O-Ring Roller Chain the first choice for applications where relubrication is next to impossible.

For Worldwide Sales and Superior Service

International

AUSTRALIA

Rexnord Australia Pty. Ltd.
P.O. Box 304
Padstow, N.S.W. 2211
Australia
Telephone: 61-2-9773-0575
Fax: 61-2-9774-5514

BRAZIL

Rexnord Correntes Ltda.
Caixa Postal, 290
93001 Sao Leopoldo – RS
Brazil
Telephone: 55-51-588-3000
Fax: 55-51-588-1334

CHINA

Rexnord Shanghai
Conch Building, Suite 621
1271 Zhenshan XI Rd.
Shanghai, China 200051
Telephone: 86-21-62 701942
Fax: 86-21-62 701943

EUROPE

Rexnord PT
Rexnord Belgium N.V.
Airport Ring Center
Maalbeekweg 17
1930 Zaventem
Belgium
Telephone: 32-2-725-4060
Fax: 32-2-720-1023

LATIN AMERICA

Rexnord International
4695 W. Greenfield Avenue
Milwaukee, WI 53204, USA
Telephone: 414/643-2242
Fax: 414/643-3222

MEXICO

Cadenas y Componentes
Rexnord, S.A. de C.V.
Boulevard Bernardo
Quintano 155-Segundo Nivel
Querétaro, Qro. 76060
México
Telephone: 52-42-23-51-99
Fax: 52-42-23-51-37

SINGAPORE

Rexnord International Inc.
36 Purvis Street
#02-01/04
Singapore 188613
Telephone: 65-338-5622
Fax: 65-338-5422

Canada

ALBERTA

9783 - 45 Avenue
Edmonton, Alberta
T6E 5V8
Telephone: 403/463-9444
Fax: 403/450-4973

BRITISH COLUMBIA

4211 Kingsway, Ste. 204
Burnaby, British Columbia
V5H 1Z6
Telephone: 604/435-5000
Fax: 604/435-6516

ONTARIO

81 Maybrook Drive
Scarborough, Ontario
M1V 3Z2
Telephone: 416/297-6868
Fax: 416/297-6873

QUEBEC

9255 Cote de Liesse Rd.
Dorval, Quebec
H9P 2N9
Telephone: 514/631-4444
Fax: 514/631-9163

U.S. Sales Offices

ATLANTA

2300 Lake Park Drive – #150
Smyrna, GA 30080
Telephone: 770/431-7300
Fax: 770/431-7298

BIRMINGHAM

3100 Lorna Road, Suite 200
Birmingham, AL 35216
Telephone: 205/822-7708
Fax: 205/979-0010

CHICAGO

2232 Wisconsin Avenue
Downers Grove, IL 60515
Telephone: 630/968-7553
Fax: 630/810-1081

CINCINNATI

8040 Hosbrook Rd. – #202
Cincinnati, OH 45236-2908
Telephone: 513/791-0601
Fax: 513/792-8793

HOUSTON

17171 Park Rd. – #150
Houston, TX 77084-4927
Telephone: 713/398-9570
Fax: 713/398-9569

KANSAS CITY

9225 Ward Parkway – #115
Kansas City, MO 64114-3324
Telephone: 816/361-8889
Fax: 816/523-5403

LOS ANGELES

444 E. Huntington Dr., Suite 208
Arcadia, CA 91006-3768
Telephone: 626/294-2310
Fax: 626/294-2314

MILWAUKEE

4601-D W. Greenfield Ave.
Milwaukee, WI 53214
Telephone: 414/643-2410
Fax: 414/643-2430

PHILADELPHIA

1004 W. Ninth Avenue
Continental Plaza
King of Prussia, PA 19406-1205
Telephone: 610/962-9980
Fax: 610/962-9984

ROANOKE

2715 Brambleton Ave. S.W.
Roanoke, VA 24015
Telephone: 540/772-0451
Fax: 540/772-3328

SEATTLE

33305 1st Way So. – #103
Federal Way, WA 98003
Telephone: 206/927-6609
Fax: 206/927-6832

U.S. Service Centers

ATLANTA

2300 Lake Park Drive – #150
Smyrna, GA 30080
Telephone: 770/431-7200
Fax: 770/431-7299

COLUMBUS

4040 Fondorf Drive
P.O. Box 28502
Columbus, OH 43228-1026
Telephone: 614/276-7235
Fax: 614/276-1137

DALLAS

1217 Corporate Drive West
Arlington, TX 76006-6103
Telephone: 817/640-3332
Fax: 817/640-8704

FRESNO

1080 W. Sierra Avenue
Suite 102
Fresno, CA 93711-2063
Telephone: 209/435-1111
Fax: 209/439-6887



Rexnord Corporation
Roller Chain Division
Box 346
Indianapolis, IN 46206
FAX: 317/267-2200
PH: 317/267-2248
www.rexnord.com