

# Linear Bushings and Shafts Inch Series

The Drive and Control Company



# Linear Motion Technology

## Linear Bushings and Shafts

Linear Bushings  
Pillow Block Sets  
Shafts  
Shaft Support Rails  
Shaft Support Blocks  
  
Ball Transfer Units  
  
Other Engineered Products

## Profiled Rail Systems

Ball Rail® Systems  
  
Roller Rail™ Systems

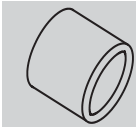
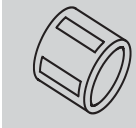
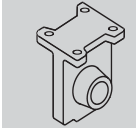
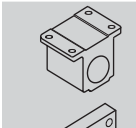
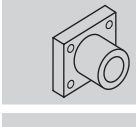
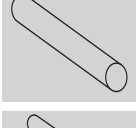
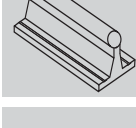
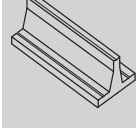
## Screw Drives

Precision Ball Screw Assemblies  
  
End Bearings and Housings

## Linear Motion Systems

Linear Motion Slides  
  
Linear Modules  
Robotic Erector System, Accessories  
  
Compact Modules  
Compact Slides  
  
Ball Rail® Tables  
  
Components for Customized  
Positioning Systems  
  
Controllers  
Electrical Accessories

# Linear Bushings and Shafts - Inch Series PAGE

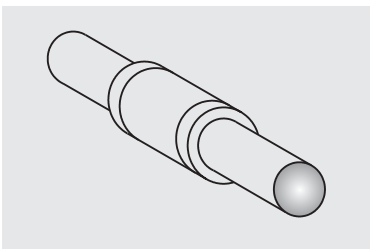
Product Overview	4	
Quick Reference Dimensions and Load Capacities	6	
General Technical Data and Mounting Instructions	8	
Standard Linear Bushings 0750-../ 0751-../ 0752-../ 0753-..	16	
Super Linear Bushings 0755-../ 0756-..	24	
Cast Iron Pillow Block Sets 1750-../ 1752-../ 1753-..	30	
Aluminum Pillow Block Sets	38	
- Single Sets      1755-../ 1756-../ 1757-..		
- Twin Sets        1760-../ 1762-../ 1763-..		
Precision Steel Shaft 1700-../ 1771-..	50	
Shaft Support Rail Assemblies 1769-../1770-..	59	
Shaft Support Rails	62	
- High Profile      1767-..		
- Low Profile        1768-..		
Shaft Support Blocks 1759-..	65	
External Retaining Rings XR-..A / XRS-..A	66	

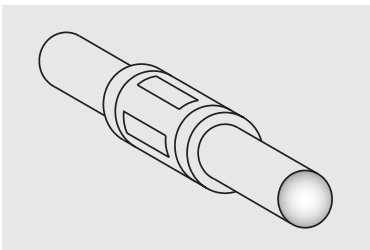
# Rexroth Linear Bushings and Shafts

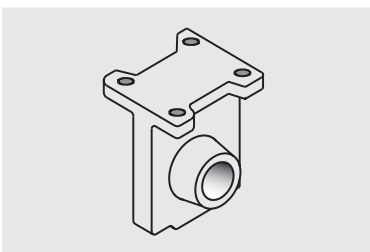
## Product Overview

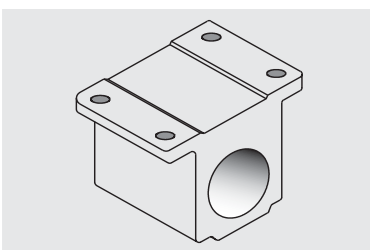
<b>Linear Bushings</b>	<b>Standard</b> 0750-..to 0753-..	<b>Features:</b>	<b>Closed/Adjustable/Open</b> Precision Bore With or without Internal Seals Corrosion Resistant
	<b>Super</b> 0755-..to 0756-..	<b>Features:</b>	<b>Closed/Open</b> Self-aligning/Adjustable Bore With or without Internal Seals Lightweight/High Load Capacity
<b>Linear Pillow Block Sets</b>	<b>Cast Iron Blocks</b> 1750-..to 1753-..	<b>Features:</b>	<b>Closed/Adjustable/Open</b> Rigid Cast Iron Self-aligning Sleeve Standard Bushing Insert
<b>Linear Shaft &amp; Assemblies</b>	<b>Aluminum Blocks</b> Single 1755...to 1757-.. Twin 1760-..to 1763-..	<b>Features:</b>	<b>Closed/Adjustable/Open</b> Super Bushing Insert Lightweight Anodized Blocks
	<b>Precision Steel Shaft</b> 1700-.., 1771-..	<b>Features:</b>	<b>Carbon/Stainless Steel</b> Plain or Predrilled Class L and S
	<b>Shaft Support Rail Assemblies</b> 1769-.. to 1770-..		<b>Aluminum/Steel</b>
<b>Shaft Supports</b>	<b>Support Rails</b> 1767-.. to 1768-..	<b>Features:</b>	<b>Aluminum/Steel Material</b> With or Without Base Flange Standard and Low profile Rigid Cast Iron Block
	<b>Support Blocks</b> 1759-..		<b>Machined Base</b>

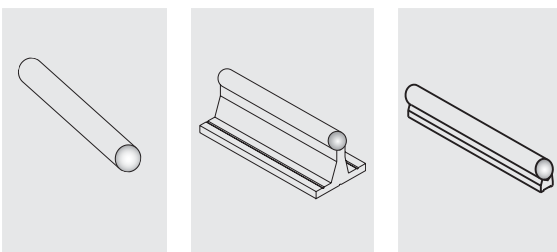
**PAGE**

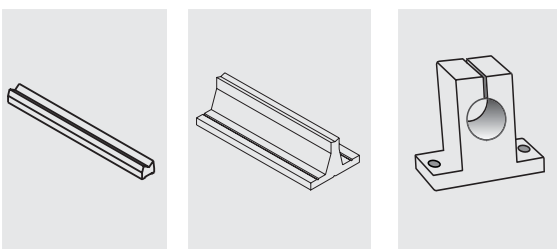
<p><b>16</b></p>		<p>Sizes 1/4" thru 4"</p> <p>Load Capacities: 46 to 4061 lbs.</p>
------------------	---	---

<p><b>24</b></p>		<p>Sizes 1/4" thru 2"</p> <p>Load Capacities: 60 to 3110 lbs.</p>
------------------	---	---

<p><b>30</b></p>		<p>Sizes 1/2" thru 2"</p> <p>Load Capacities: 177 to 1320 lbs.</p>
------------------	--	--

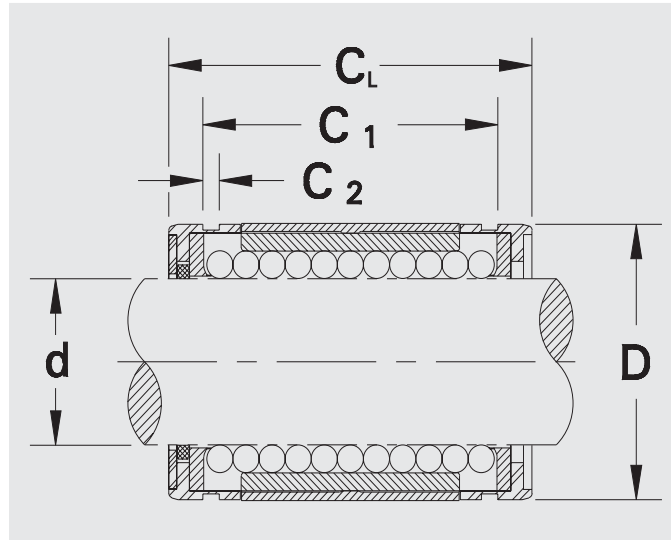
<p><b>38</b></p>		<p>Sizes 1/4" thru 2" (Single and Twin Blocks)</p> <p>Load Capacities: 42 to 4000 lbs.</p>
------------------	---	--

<p><b>50</b></p>		<p>Shaft Diameters 1/4" thru 4"</p> <p>Assemblies 1/2" thru 2"</p>
------------------	---	--

<p><b>62</b></p>		<p>Support Rails Sizes 1/2" thru 2"</p> <p>Support Blocks Sizes 1/4" thru 2"</p>
------------------	---	--

# Quick Reference - Dimensions and Load Capacities Standard and Super Linear Bushings

## Basic Mounting Dimensions



(Figure 1)

Nominal Shaft Diameter	Standard Linear Bushings				Super Linear Bushings			
	D	C <sub>L</sub>	C <sub>1</sub>	*C <sub>2</sub>	D	C <sub>L</sub>	C <sub>1</sub>	*C <sub>2</sub>
0.2500	0.5000	0.7500	0.5110	0.0390	0.5000	0.750	0.515	0.0390
0.3750	0.6250	0.8750	0.6385	0.0390	0.6250	0.875	0.703	0.0390
0.5000	0.8750	1.2500	0.9625	0.0459	0.8750	1.250	1.032	0.0459
0.6250	1.1250	1.5000	1.1039	0.0559	1.1250	1.500	1.112	0.0559
0.7500	1.2500	1.6250	1.1657	0.0559	1.2500	1.625	1.272	0.0559
1.0000	1.5625	2.2500	1.7547	0.0679	1.5625	2.250	1.886	0.0679
1.2500	2.0000	2.6250	2.0047	0.0679	2.0000	2.625	2.011	0.0679
1.5000	2.3750	3.0000	2.4118	0.0859	2.3750	3.000	2.422	0.0859
2.0000	3.0000	4.0000	3.1917	0.1029	3.0000	4.000	3.206	0.1029
2.5000	3.7500	5.0000	3.9760	0.1200				
3.0000	4.5000	6.0000	4.7260	0.1200				
4.0000	6.0000	8.0000	6.2580	0.1389				

(Table 1)

\*Groove dimensions conform to MIL-R-21248B (Industrial External Retaining Rings)

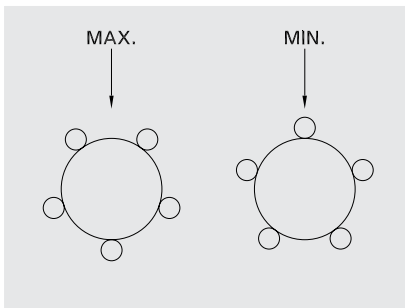
Note: Dimensions listed are nominal measurements in inches. (See bushing spec sheets for tolerances.)

## Load Capacities

Load Correction Factor  $-f_{max}$

$$C_{max} = C_{min} \cdot f_{max}$$

Figure 2 illustrates the basic theory of Load Capacity  $C_{min}$  and  $C_{max}$  given in table 3.  $C_{min}$  and  $C_{max}$  represent the bushing capacity rating if the direction of load in relation to ball position is known. The  $f_{max}$  load correction factor is used to calculate the maximum load capacity when the direction of load is known, and is shared by two or more ball circuits depending on the size of Linear Bushing.



(Figure 2)

Nominal Shaft Diameter (Standard)	Load Correction Factor $f_{max}$	Nominal Shaft Diameter (Super)	Load Correction Factor $f_{max}$
1/4"	1.000	1/4" - 1/2"	1.414
3/8"-5/8"	1.414	5/8"	1.463
3/4"	1.463	3/4" - 2"	1.280
1-4"	1.280		

(Table 2)

Nominal Shaft Diameter	Standard Linear Bushings			Super Linear Bushing		
	C (lbf) min.	C (lbf) **max.	$C_o$ (lbf)	C (lbf) min.	C (lbf) **max.	$C_o$ (lbf)
0.2500	46	46	60	60	85	80
0.3750	51	72	71	95	134	120
0.5000	115	163	176	230	325	290
0.6250	174	246	266	401	587	502
0.7500	194	284	308	470	602	592
1.0000	221	283	353	851	1089	1062
1.2500	353	452	617	1231	1576	1532
1.5000	491	628	905	1483	1898	1852
2.0000	860	1101	1787	2430	3110	3038
2.5000	1058	1354	2250			
3.0000	1654	2117	3600			
4.0000	3173	4061	7830			

(Table 3)

\*\*Max. ratings are based upon the use of Load Correction Factor  $-f_{max}$  in Table 2

Note: Load ratings are based upon a nominal travel life of 2,000,000 inches, operating on a shaft with a hardness range of  $R_c$  58-64.

# Rexroth Linear Bushings

## General Technical Data and Mounting Instructions

### Calculating Travel Life

In determining travel life of a Linear Bushing, there are several factors to be considered. These factors are the load rating of linear bushing, resultant forces acting on the linear bushing, shaft hardness, and operating temperature.

The values for dynamic load capacities (C), have been calculated based on a nominal travel life of 2,000,000 inches.

The formula for calculating travel life is as follows:

$$L = \left[ \frac{C \cdot f_H \cdot f_t}{P} \right]^3 \cdot 2 \cdot 10^6$$

$$L_h = \frac{L}{2 \cdot s \cdot n \cdot 60}$$

L = nominal travel life (inches)

C = basic dynamic load rating (lbs)

P = resultant of external forces (lbs)

$f_H$  = shaft hardness factor

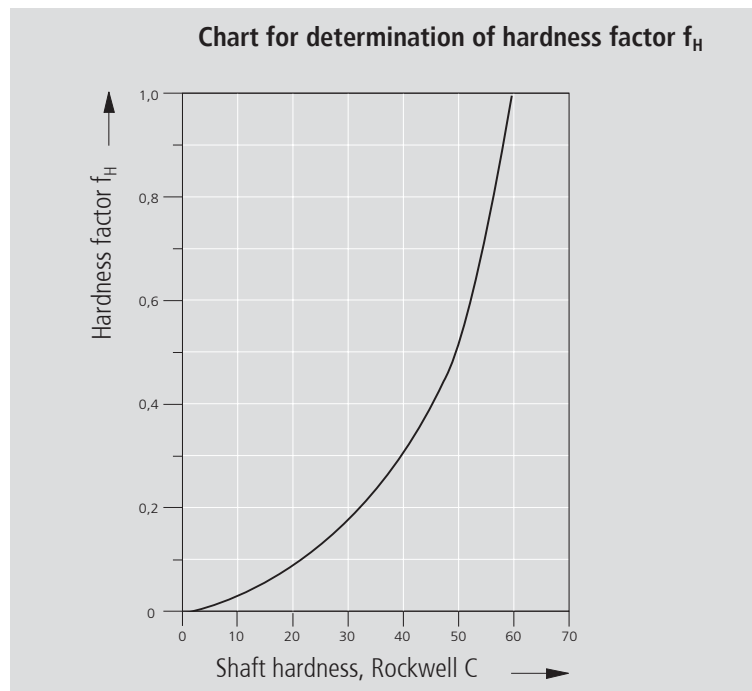
$f_t$  = temperature factor

$L_h$  = nominal rated life (hrs)

s = stroke length (inches)

n = stroke repetition rate (full cycle) (min<sup>-1</sup>)

### Shaft Hardness Factor - $f_H$



### Operating Temperature Factor - $f_t$

Bushing temperature, °F	212	255	300	345	395
Temperature factor, $f_t$	1	0.95	0.90	0.84	0.73

(Table 4)



## Calculating Load Capacity

The formula for calculating load capacity is as follows:

$$C = \frac{P}{f_H \cdot f_t \cdot f_L}$$

C = dynamic load capacity (lbs)

P = resultant of external forces (lbs)

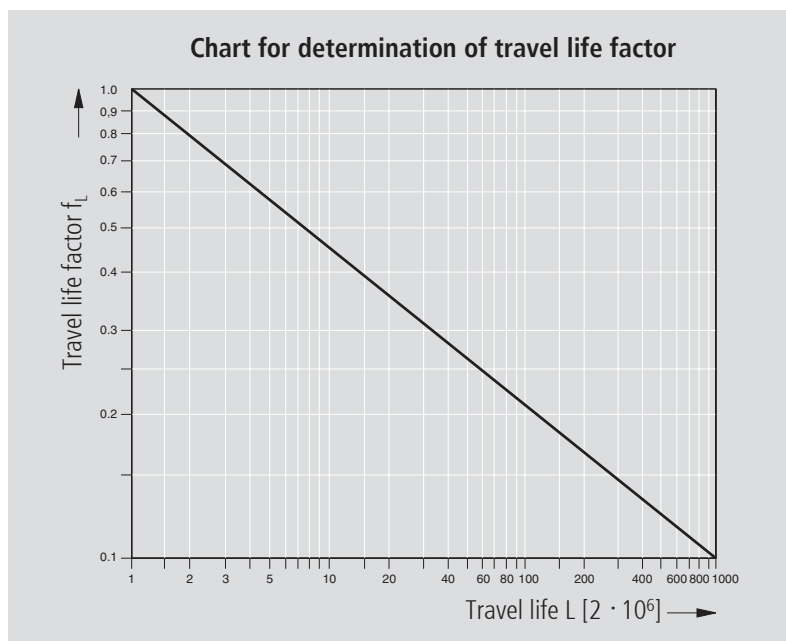
$f_H$  = shaft hardness factor

$f_t$  = temperature factor

$f_L$  = travel life factor (inches)

Travel Life Factor -  $f_L$

Chart for determination of travel life factor -  $f_L$



## Friction Evaluation - F

Calculating frictional resistance requires values for load and seal resistance.

Frictional Resistance is expressed:

$$F = \mu \cdot P + f$$

F = frictional resistance (lbs)  
 $\mu$  = coefficient of friction - (Table 5)  
 P = load (lbs)  
 f\* = seal resistance (lbs)  
 \*(range .4 to 1.1 lbs)

## Coefficient of Friction - $\mu$

Transition from low to high speeds in the Bosch Rexroth Assemblies is smooth due to the extremely low friction coefficients.

Bushing Type	*Coefficient of friction
Standard -0750 to 0753	0.002 to 0.004
Super -0755 to 0756	0.002 to 0.003

(Table 5)

\* Based upon normal loading factors and proper lubrication.

# Rexroth Linear Bushings

## General Technical Data and Mounting Instructions

### Maximum Velocity

Type	V <sub>max</sub> (ft/s)
Standard and Super Bushing $\phi$ d 1/4" - 4"	5

(Table 6)

### Lubrication

Rexroth Linear Bushings are supplied with an anti-corrosion agent that provides protection for their steel components as well as the initial lubrication properties for operation. It is recommended that either grease or oil be used as the primary lubricant.

In most cases, the use of grease as a lubricant is preferable because it is more viscous than oil. Therefore, the grease will help to seal off the Linear Bushing and adhere to its surfaces better than oil. Longer relube intervals will result.

For Lubrication\*: Use either a petroleum or ester base lubricant, or turbine oil conforming to ISO Standards G32 to G68 or lithium based grease grade NLGI 2.

Examples of factors affecting lubrication intervals:

- Load
- Velocity
- Motion sequence
- Temperature

Where short relube intervals may be necessary:

- High loads
- High velocity (up to V<sub>max</sub>)
- Short stroke (stroke is shorter than length of linear bushing)
- Low resistance to aging in the lubricant

Normal re-lubrication service intervals are recommended to be performed every 500,000 inches of travel or as needed.

\*Note: For best results, observe the lubricant manufacturer's instruction for use.

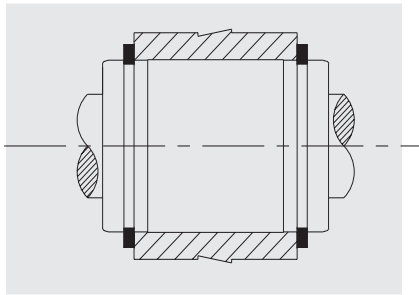
## Installation and Mounting

Proper housing bore dimension, shaft diameter, and shaft alignment are critical for accuracy and extended service life of a Linear Bushing assembly. Rexroth recommends a slight press fit on both the Standard and Super Linear Bushing series. This can vary depending upon assembly configuration.

### Examples of Mounting

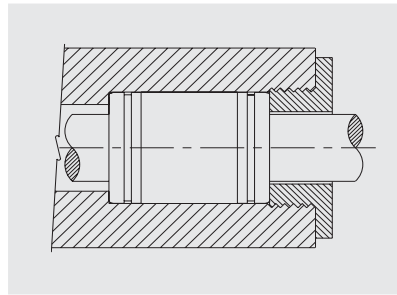
**Figure 1**

Retention by external retaining rings.



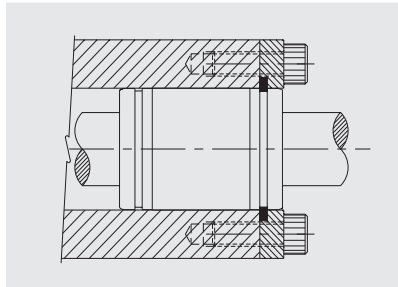
**Figure 2**

Retention by housing shoulder and threaded cap.



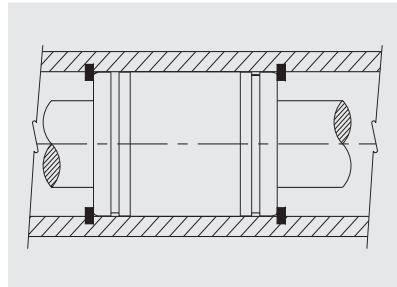
**Figure 3**

Retention by cover plate and external snap ring.

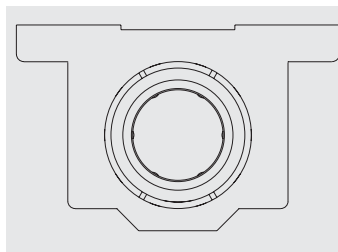


**Figure 4**

Retention by internal retaining rings.



### Pillow Blocks



For simple bushing installation use Rexroth Aluminum or Cast Iron Pillow Blocks.

Available in closed, adjustable, open, single, twin, or flange styles.

(See the section for Pillow Block Sets starting on Page 30.)

Note: Linear Bushings should be handled with care during installation into the housing bore. A slight chamfer is preferred on the leading edge of the housing bore to prevent damage to the Linear Bushing during installation.

# Rexroth Linear Bushings

## General Technical Data and Mounting Instructions

### Assembly Considerations

Debris and foreign material must be kept from entering the Linear Bushing assembly during installation, as this could cause early failure of the bushing.

In order for components to operate properly, ensure that the mounting surface, bore tolerance and the proper shaft diameter are accurate prior to installation.

### Housing Bore Considerations

Clearance between the bushing bore and shaft is controlled by the housing bore tolerance and shaft diameter tolerance. These should be matched for a close tolerance fit.

Be careful of an interference fit between the outside diameter of the Linear Bushing and the bore diameter of the housing. An interference between the Linear Bushing and housing bore may cause a reduction in life for both the bushing and shaft, and may also effect the performance.

### Shaft Alignment

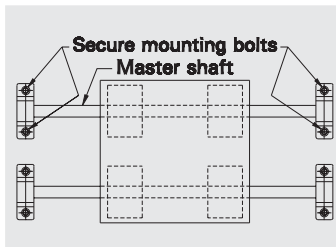
Parallelism on shaft alignment is critical for accuracy and to prevent binding of the assembly during operation.

Bosch Rexroth recommends that parallelism not exceed .001" between shafts along the length of the assembly.

### Example of Shaft Alignment

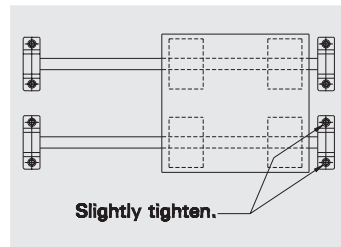
#### Step 1

Align the Master Shaft to reference points that are parallel to the centerline then secure mounting bolts.



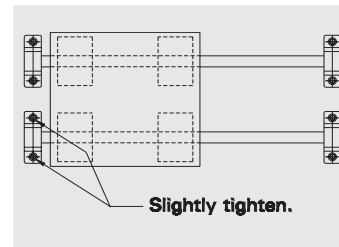
#### Step 2

Once the Master Shaft is in place, mount a second shaft in place positioned off the same reference points. (Slightly tighten.)



#### Step 3

As the assembly is moved one end to the other, the mounting bolts should be secured. Then the mounting bolts may be tightened down for the final operation.



Note: Self-aligning bushings will not compensate for shaft out-of-parallelism specifications.

# Shafts and Housings

## Shaft Considerations

To ensure the optimal performance of Rexroth Linear Bushings, precision shafts and housings are essential.

Appropriate clearance between the Rexroth Bushings and shaft is necessary for reliable performance. Inadequate radial clearance could cause premature failure as well as rough travel.

Dimensional tolerance, hardness and surface finish of the shaft greatly affect the operational performance of Linear Bushings.

The shaft must meet these specifications:

- Correct O.D. tolerance of the nominal shaft size on table 60, page 56.
- Hardness of HRC 60-64. Hardness of less than HRC 60 will dramatically reduce life and permissible load. Hardness over HRC 64 will accelerate ball wear.
- Depth must be a minimum of .04 inches.
- Surface finish of 14 RA microinches ( $R_a$  0.35) or less.

## Recommended Tolerance for Housing Bore

Proper selection and sizing of a housing bore will ensure consistent bushing performance. Rexroth Bushing housing bore recommendations offer slip-fit with the bushing O.D. for improved service life.

See 'Recommended Housing Bore' section in the Dimensions and Specifications pages for Linear Inch Bushings. ISO recommendations are indicated in Table 7, page 14.

# General Technical Data and Mounting Instructions

## Metric Tolerances for inside dimensions

Tolerances in  $\mu\text{m} = 0.001 \text{ mm}$

Rated dimensions (mm)	ISO Tolerances for inside dimensions														
	G7	H5	H6	H7	H8	H11	H12	H13	JS6	JS7	JS14	K6	K7	M6	P9
between 3 and 6	+16 +4	+5 0	+8 0	+12 0	+18 0	+75 0	+120 0	+180 0	+4 -4	+6 -6	+150 -150	+2 -6	+3 -9	-1 -9	-12 -42
between 6 and 10	+20 +5	+6 0	+9 0	+15 0	+22 0	+90 0	+150 0	+220 0	+4.5 -4.5	+7.5 -7.5	+180 -180	+2 -7	+5 -10	-3 -12	-15 -51
between 10 and 18	+24 +6	+8 0	+11 0	+18 0	+27 0	+110 0	+180 0	+270 0	+5.5 -5.5	+9 -9	+215 -215	+2 -9	+6 -12	-4 -15	-18 -61
between 18 and 30	+28 +7	+9 0	+13 0	+21 0	+33 0	+130 0	+210 0	+330 0	+6.5 -6.5	+10.5 -10.5	+260 -260	+2 -11	+6 -15	-4 -17	-22 -74
between 30 and 50	+34 +9	+11 0	+16 0	+25 0	+39 0	+160 0	+250 0	+390 0	+8 -8	+12.5 -12.5	+310 -310	+3 -13	+7 -18	-4 -20	-26 -88
between 50 and 80	+40 +10	+13 0	+19 0	+30 0	+46 0	+190 0	+300 0	+460 0	+9.5 -9.5	+15 -15	+370 -370	+4 -15	+9 -21	-5 -24	-32 -106
between 80 and 120	+47 +12	+15 0	+22 0	+35 0	+54 0	+220 0	+350 0	+540 0	+11 -11	+17.5 -17.5	+435 -435	+4 -18	+10 -25	-6 -28	-37 -124
between 120 and 180	+54 +14	+18 0	+25 0	+40 0	+63 0	+250 0	+400 0	+630 0	+12.5 -12.5	+20 -20	+500 -500	+4 -21	+12 -28	-8 -33	-43 -143
between 180 and 250	+61 +15	+20 0	+29 0	+46 0	+72 0	+290 0	+460 0	+720 0	+14.5 -14.5	+23 -23	+575 -575	+5 -24	+13 -33	-8 -37	-50 -165

(Table 7)

Conversion from millimeters to inches

	Millimeters	$\mu\text{m}$	Inches
<b>1 millimeter</b>	1	1000	0.0393701
<b>1 <math>\mu\text{m}</math></b>	0.001	1	$3.93701 \times 10^{-5}$
<b>1 inch</b>	25.4	25400	1

(Table 8)

Example of conversion from  $\mu\text{m}$  to inches:

What are the tolerances (in inches) for a bore of 3.5 inch diameter?

Bore diameter 3.5 inch =  $3.5 \cdot 25.4 \text{ mm} = 88.9 \text{ mm}$

For a bore diameter of 88.9 mm and a tolerance range of H7, the upper tolerance limit is +35  $\mu\text{m}$  and the lower tolerance limit 0  $\mu\text{m}$

Max. size = +35  $\mu\text{m} = +35 \cdot 3.93701 \times 10^{-5} \text{ inch} = 1.3779 \times 10^{-3} \text{ inch}$

Min. size = 0  $\mu\text{m}$  (0 inch)

## Metric Tolerances for outside dimensions

Tolerances in  $\mu\text{m} = 0.001 \text{ mm}$

Rated dimensions (mm)	ISO Tolerances for outside dimensions														
	g7	h5	h6	h7	h8	h11	h12	h13	js6	js7	js14	k6	k7	m6	p9
between 3 and 6	-4 -16	0 -5	0 -8	0 -12	0 -18	0 -75	0 -120	0 -180	+4 -4	+6 -6	+150 -150	+9 +1	+13 +1	+12 +4	+42 +12
between 6 and 10	-5 -20	0 -6	0 -9	0 -15	0 -22	0 -90	0 -150	0 -220	+4.5 -4.5	+7.5 -7.5	+180 -180	+10 +1	+16 +1	+15 +6	+51 +15
between 10 and 18	-6 -24	0 -8	0 -11	0 -18	0 -27	0 -110	0 -180	0 -270	+5.5 -5.5	+9 -9	+215 -215	+12 +1	+19 +1	+18 +7	+61 +18
between 18 and 30	-7 -28	0 -9	0 -13	0 -21	0 -33	0 -130	0 -210	0 -330	+6.5 -6.5	+10.5 -10.5	+260 -260	+15 +2	+23 +2	+21 +8	-
between 30 and 50	-9 -34	0 -11	0 -16	0 -25	0 -39	0 -160	0 -250	0 -390	+8 -8	+12.5 -12.5	+310 -310	+18 +2	+27 +2	+25 +9	-
between 50 and 80	-10 -40	0 -13	0 -19	0 -30	0 -46	0 -190	0 -300	0 -460	+9.5 -9.5	+15 -15	+370 -370	+21 +2	+32 +2	+30 +11	-
between 80 and 120	-12 -47	0 -15	0 -22	0 -35	0 -54	0 -220	0 -350	0 -540	+11 -11	+17.5 -17.5	+435 -435	+25 +3	+38 +3	+35 +13	-
between 120 and 180	-14 -54	0 -18	0 -25	0 -40	0 -63	0 -250	0 -400	0 -630	+12.5 -12.5	+20 -20	+500 -500	+28 +3	+43 +3	+40 +15	-
between 180 and 250	-15 -61	0 -20	0 -29	0 -46	0 -72	0 -290	0 -460	0 -720	+14.5 -14.5	+23 -23	+575 -575	+33 +4	+50 +4	+46 +17	-

(Table 9)

# Rexroth Linear Bushings

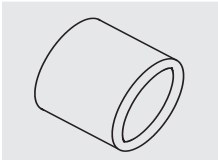
## Linear Bushings - Overview

Page

### Standard Series

#### **Closed Type**

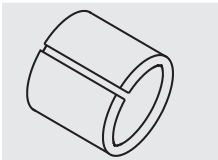
Standard bushing with precision fixed bore.



18

#### **Adjustable Type**

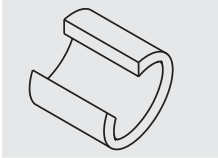
For use when zero clearance or pre-load is required.



20

#### **Open Type**

For use with assemblies where the shaft is fully supported.

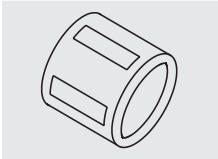


22

### Super Series

#### **Closed Type**

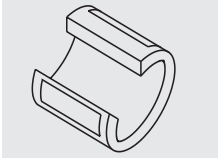
Self-aligning bushing with high load capacity and adjustable working bore.



26

#### **Open Type**

For use with the assemblies where the shaft is fully supported.



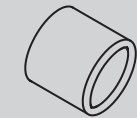
28



## Standard Linear Bushings

### The Rexroth Standard Linear Bushing consists of:

- A hardened and ground outer sleeve
- Low noise resin ball retainer
- Balls made of quality anti-friction bearing steel
- Available integral seal design
- Also available in corrosion resistant material



### Types

- Closed



- Adjustable



- Open



### Advantages

- Low friction
- High running speeds
- Sturdy, solid steel construction suited to industrial workshop environments
- Insensitive to dirt, an important feature for industrial environments

### Temperature Ratings

- Continuous: - 4°F to 180°F

# Rexroth Standard Linear Bushings

## Standard Linear Bushings, 0750-

Closed type - for use on unsupported shaft

### Structural design

- Hardened and ground outer sleeve
- Low noise, lightweight resin ball retainer
- Balls made of high quality anti-friction bearing steel
- With or without integral seals



### Ordering Data

Nominal Shaft Diameter (in.)	Part Numbers		Mass (lb)	Corresponding External Retaining Ring <sup>(1)</sup>
	without seals	with two seals		
0.2500	0750-004-00	0750-204-00	0.02	XR-4A
0.3750	0750-006-00	0750-206-00	0.03	XR-6A
0.5000	0750-008-00	0750-208-00	0.09	XR-8A
0.6250	0750-010-00	0750-210-00	0.19	XR-10A
0.7500	0750-012-00	0750-212-00	0.23	XR-12A
1.0000	0750-016-00	0750-216-00	0.44	XR-16A
1.2500	0750-020-00	0750-220-00	0.98	XR-20A
1.5000	0750-024-00	0750-224-00	1.48	XR-24A
2.0000	0750-032-00	0750-232-00	2.52	XR-32A
2.5000	*0750-040-00	*0750-240-00	5.73	XR-40**
3.0000	*0750-048-00	*0750-248-00	9.66	XR-48**
4.0000	*0750-064-00	*0750-264-00	22.49	XR-64**

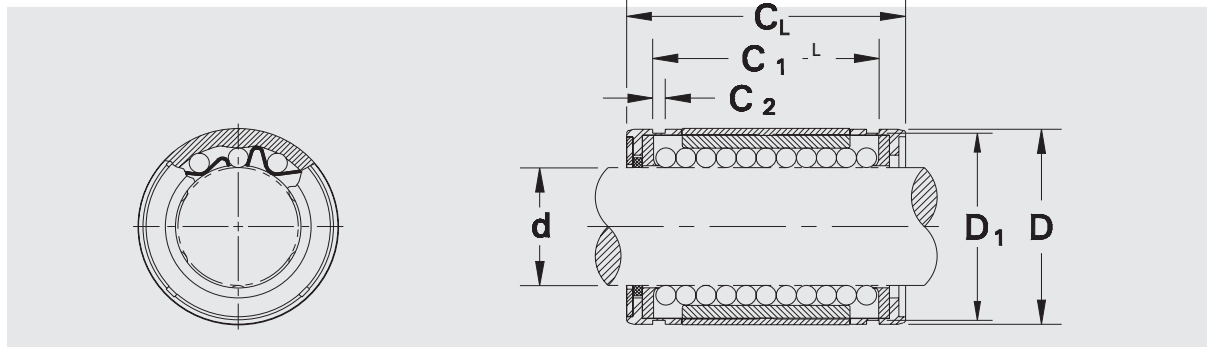
(Table 10)

- Consult factory for details and availability:  
 Single seal versions 0750-1...  
 Extra precision bore series 0751-...  
 Corrosion resistant series 0750-...53

\* Sizes available in steel ball cage only  
 \*\*Commercial series XR-rings with end lugs

(1) See page 71 for retaining ring dimensions

## Dimensions and Specifications



(Figure 3)

### Dimensions (inches)

Bore d	D <sub>(1)</sub>	C <sub>L(2)</sub>	C <sub>1</sub>	C <sub>2</sub>	D <sub>1</sub>
.2500/.2496	0.5000	0.7500	0.5110	0.0390	0.4687
.3750/.3746	0.6250	0.8750	0.6358	0.0390	0.5880
.5000/.4996	0.8750	1.2500	0.9625	0.0459	0.8209
.6250/.6246	1.1250	1.5000	1.1039	0.0559	1.0590
.7500/.7496	1.2500	1.6250	1.1657	0.0559	1.1760
1.0000/.9996	1.5625	2.2500	1.7547	0.0679	1.4687
1.2500/1.2495	2.0000	2.6250	2.0047	0.0679	1.8859
1.5000/1.4995	2.3750	3.0000	2.4118	0.0859	2.2389
2.0000/1.9995	3.0000	4.0000	3.1917	0.1029	2.8379
2.5000/2.4994	3.7500	5.0000	3.9760	0.1200	3.5519
3.0000/2.9994	4.5000	6.0000	4.7260	0.1200	4.3100
4.0000/3.9992	6.0000	8.0000	6.2580	0.1389	5.7450

(Table 11)

### Specifications

Nominal Shaft Diameter (in.)	Recommended Housing Bore <sup>(3)</sup>	Load Capacity <sup>(4)</sup>		No. of Ball Circuits
		dyn. C (lbf)	stat. C <sub>0</sub> (lbf)	
0.2500	0.5000 / 0.5004	46	60	3
0.3750	0.6250 / 0.6254	51	71	4
0.5000	0.8750 / 0.8755	115	176	4
0.6250	1.1250 / 1.1255	174	266	4
0.7500	1.2500 / 1.2506	194	308	5
1.0000	1.5625 / 1.5631	221	353	6
1.2500	2.0000 / 2.0007	353	617	6
1.5000	2.3750 / 2.3757	491	905	6
2.0000	3.0000 / 3.0007	860	1787	6
2.5000	3.7500 / 3.7509	1058	2250	6
3.0000	4.5000 / 4.5009	1654	3600	6
4.0000	6.0000 / 6.0010	3173	7830	6

(Table 12)

Notes:

(1) Outer diameter tolerance see ISO table, page 15.

(2) Length tolerance -

Bore size -

d 0.2500- 0.7500 + 0/ -0.008"

d 1.0000 - 2.5000 + 0/ -0.012"

d 3.0000 - 4.0000 + 0/ -0.016"

(3) Transition fit

(4) See table 2 -page 7 for load correction factors

# Rexroth Standard Adjustable Linear Bushing

**Standard linear Bushings, 0752-**  
Adjustable type - for use on unsupported shaft

## Structural design

- Adjustable radial clearance
- Hardened and ground outer sleeve
- Low noise, lightweight resin ball retainer
- Balls made of high quality anti-friction bearing steel
- With or without integral seals



## Ordering Data

Nominal Shaft Diameter (inches)	Part Numbers		Mass (lb)	Corresponding External Retaining Ring <sup>(1)</sup>
	without seals	with two seals		
0.5000	0752-008-00	0752-208-00	0.09	XR-8A
0.6250	0752-010-00	0752-210-00	0.18	XR-10A
0.7500	0752-012-00	0752-212-00	0.22	XR-12A
1.0000	0752-016-00	0752-216-00	0.45	XR-16A
1.2500	0752-020-00	0752-220-00	0.96	XR-20A
1.5000	0752-024-00	0752-224-00	1.47	XR-24A
2.0000	0752-032-00	0752-232-00	2.48	XR-32A
2.5000	*0752-040-00	*0752-240-00	5.64	XR-40**
3.0000	*0752-048-00	*0752-248-00	9.59	XR-48**
4.0000	*0752-064-00	*0752-264-00	22.38	XR-64**

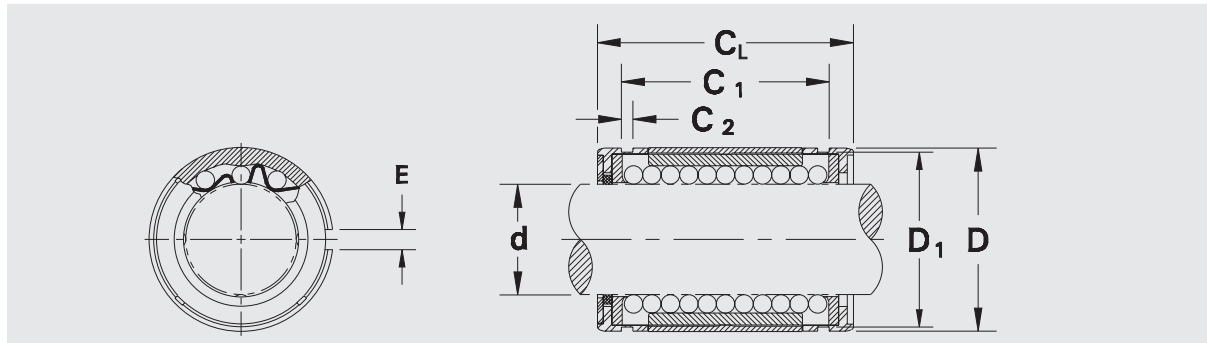
(Table 13)

- Consult factory for details and availability:  
Single seal versions 0752-1...  
Corrosion resistant series 0752-...-53

\* Sizes available with steel ball cage only  
\*\*Commercial series XR-rings with end lugs

(1) See page 71 for retaining ring dimensions

## Dimensions and Specifications



(Figure 4)

### Dimensions (inches)

Bore d	D <sub>(1)</sub>	C <sub>L(2)</sub>	C <sub>1</sub>	C <sub>2</sub>	D <sub>1</sub>	E
.5000/.4996	0.8750	1.2500	0.9625	0.0459	0.8209	0.06
.6250/.6246	1.1250	1.5000	1.1039	0.0559	1.0590	0.06
.7500/.7496	1.2500	1.6250	1.1657	0.0559	1.1760	0.06
1.0000/.9996	1.5625	2.2500	1.7547	0.0679	1.4687	0.06
1.2500/1.2495	2.0000	2.6250	2.0047	0.0679	1.8859	0.10
1.5000/1.4995	2.3750	3.0000	2.4118	0.0859	2.2389	0.12
2.0000/1.9995	3.0000	4.0000	3.1917	0.1029	2.8379	0.12
2.5000/2.4994	3.7500	5.0000	3.9760	0.1200	3.5519	0.12
3.0000/2.9994	4.5000	6.0000	4.7260	0.1200	4.3100	0.12
4.0000/3.9992	6.0000	8.0000	6.2580	0.1389	5.7450	0.12

(Table 14)

### Specifications

Nominal Shaft Diameter	Recommended Housing Bore <sup>(3)</sup>	Load Capacity <sup>(4)</sup>		No. of Ball Circuits
		dyn. C (lbf)	stat. C <sub>0</sub> (lbf)	
0.5000	0.8750 / 0.8755	115	176	4
0.6250	1.1250 / 1.1255	174	266	4
0.7500	1.2500 / 1.2506	194	308	5
1.0000	1.5625 / 1.5631	221	353	6
1.2500	2.0000 / 2.0007	353	617	6
1.5000	2.3750 / 2.3757	491	905	6
2.0000	3.0000 / 3.0007	860	1787	6
2.5000	3.7500 / 3.7509	1058	2250	6
3.0000	4.5000 / 4.5009	1654	3600	6
4.0000	6.0000 / 6.0010	3173	7830	6

(Table 15)

Notes:

(1) Outer diameter tolerance see ISO table, page 15.

(2) Length tolerance -

Bore size -

d 0.2500- 0.7500 + 0/ -0.008"

d 1.0000 - 2.5000 + 0/ -0.012"

d 3.0000 - 4.0000 + 0/ -0.016"

(3) Transition fit

(4) See table 2 -page 7 for load correction factors

# Rexroth Standard Open Linear Bushings

## Standard Linear Bushing, 0753-

Open type - for use on supported shaft

### Structural design

- Hardened and ground outer sleeve
- Low noise, lightweight resin ball retainer
- Balls made of high quality anti-friction bearing steel
- With or without integral seals



### Ordering Data

Nominal Shaft Diameter	Part Numbers		Mass (lb)	Corresponding External Retaining Ring <sup>(1)</sup>
	without seals	with two seals		
0.5000	0753-008-00	0753-208-00	0.07	XR-8A
0.6250	0753-010-00	0753-210-00	0.14	XR-10A
0.7500	0753-012-00	0753-212-00	0.19	XR-12A
1.0000	0753-016-00	0753-216-00	0.42	XR-16A
1.2500	0753-020-00	0753-220-00	0.86	XR-20A
1.5000	0753-024-00	0753-224-00	1.34	XR-24A
2.0000	0753-032-00	0753-232-00	2.47	XR-32A
2.5000	*0753-040-00	*0753-240-00	4.92	n/a
3.0000	*0753-048-00	*0753-248-00	8.27	n/a
4.0000	*0753-064-00	*0753-264-00	19.27	n/a

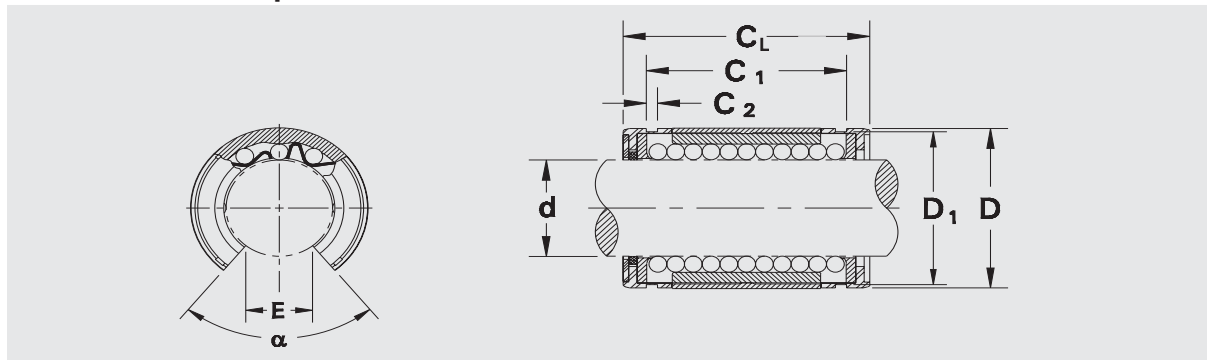
(Table 16)

- Consult factory for details and availability:  
 Single seal versions 0753-1...-..  
 Corrosion resistant series 0753-...-53

\* Sizes available with steel ball cage only

(1) See page 71 for retaining ring dimensions

## Dimensions and Specifications



(Figure 5)

### Dimensions (inches)

Bore d	D <sub>(1)</sub>	C <sub>L(2)</sub>	C <sub>1</sub>	C <sub>2</sub>	D <sub>1</sub>	E	α
.5000/.4996	0.8750	1.2500	0.9625	0.0459	0.8209	0.340	80°
.6250/.6246	1.1250	1.5000	1.1039	0.0559	1.0590	0.375	80°
.7500/.7496	1.2500	1.6250	1.1657	0.0559	1.1760	0.438	60°
1.0000/.9996	1.5625	2.2500	1.7547	0.0679	1.4687	0.563	50°
1.2500/1.2495	2.0000	2.6250	2.0047	0.0679	1.8859	0.625	50°
1.5000/1.4995	2.3750	3.0000	2.4118	0.0859	2.2389	0.750	50°
2.0000/1.9995	3.0000	4.0000	3.1917	0.1029	2.8379	1.000	50°
2.5000/2.4994	3.7500	5.0000	3.9760	0.1200	3.5519	1.250	50°
3.0000/2.9994	4.5000	6.0000	4.7260	0.1200	4.3100	1.500	50°
4.0000/3.9992	6.0000	8.0000	6.2580	0.1389	5.7450	2.000	50°

(Table 17)

### Specifications

Nominal Shaft Diameter (in.)	Recommended Housing Bore <sup>(3)</sup>	Load Capacity <sup>(4), (5)</sup>		No. of Ball Circuits
		dyn. C (lbf)	stat. C <sub>0</sub> (lbf)	
0.5000	0.8750 / 0.8755	115	176	3
0.6250	1.1250 / 1.1255	174	266	3
0.7500	1.2500 / 1.2506	194	308	5
1.0000	1.5625 / 1.5631	221	353	5
1.2500	2.0000 / 2.0007	353	617	5
1.5000	2.3750 / 2.3757	491	905	5
2.0000	3.0000 / 3.0007	860	1787	5
2.5000	3.7500 / 3.7509	1058	2250	5
3.0000	4.5000 / 4.5009	1654	3600	5
4.0000	6.0000 / 6.0010	3173	7830	5

(Table 18)

Notes:

(1) Outer diameter tolerance see ISO table, page 15.

(2) Length tolerance -

Bore size -

d 0.2500- 0.7500 + 0/ -0.008"

d 1.0000 - 2.5000 + 0/ -0.012"

d 3.0000 - 4.0000 + 0/ -0.016"

(3) Transition fit

(4) See table 2 -page 7 for load correction factors

(5) 50% derating required when load is applied through open side.

# Super Linear Bushings

## Super Linear Bushing Self-aligning

### The Super Linear Bushing consists of:

- Ball retainer and outer sleeve made of light weight polyamide
- Hardened steel load plates with ground ball tracks
- Balls made of high quality anti-friction bearing steel
- Adjustable bores (open and closed)
- With or without integral seals



### Types

- closed



- open



### Advantages

- Low friction operation
- Low noise, lightweight
- Self-aligning to one degree inclusive
- Radial clearance adjustable
- High load capacities

### Temperature Ratings

- Continuous: -4°F to 180°F



## Self-alignment

Rexroth's Super Linear Bushings compensate for alignment errors of up to one degree without reduction of load capacity.

The steel load plates are designed with the central portion of the plate slightly larger than the ends. This design serves as a fulcrum point to allow for each load plate to compensate for minor errors in alignment between shaft and housing bore caused by inaccurate machining or shaft deflection.

### Results:

Much smoother operation, higher load capacity and substantially longer travel life than conventional Linear Bushings.

## Ground Ball Tracks

Each load plate has a ground surface raceway providing low friction and high load.

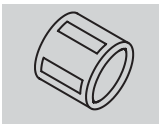
## Cost Effective Design

With its high load capacity and ability to compensate for inaccurate machine tolerances, the Super Linear Bushing allows for use of smaller components in the application. Shaft, bushing, and housing can be reduced, thereby saving money and design consideration of all the elements.

## Load Capacity and Travel Life

The Super Linear Bushing provides up to three times the load capacity and 27 times the travel life of Standard Linear Bushings, due to its special load plate design.

**Note:** Contact the factory for details on the Rexroth Super Linear Bushing design and rating information.



# Rexroth Super Linear Bushing

## Super Linear Bushing, 0755-

Closed type - for use on unsupported shaft

### Structural design

- Lightweight resin retainer and outer sleeve
- Hardened and ground steel bearing load plates
- Balls made of high quality anti-friction bearing steel
- With or without integral seals
- Self-aligning to one degree inclusive



### Ordering Data

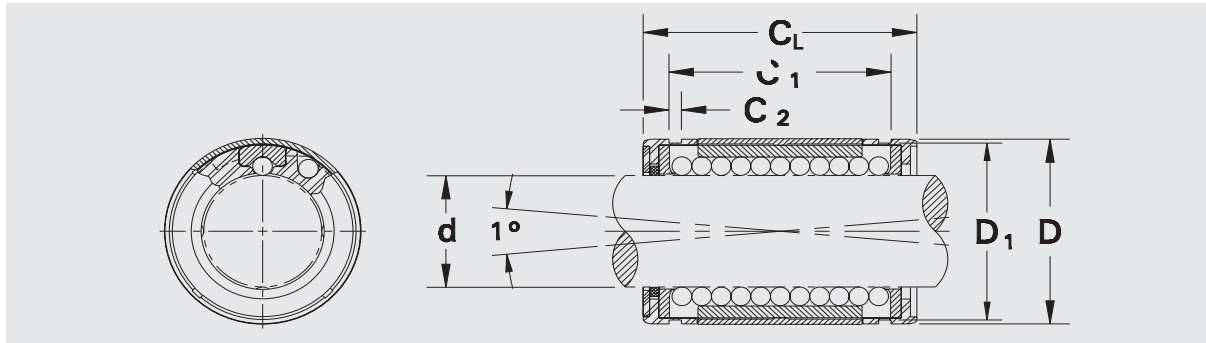
Nominal Shaft Diameter (inches)	Part Numbers		Mass (lb)	Corresponding External Retaining Ring <sup>(1)</sup>
	without seals	with two seals		
0.2500	0755-004-00	0755-204-00	0.01	XR-4A
0.3750	0755-006-00	0755-206-00	0.01	XR-6A
0.5000	0755-008-00	0755-208-00	0.04	XR-8A
0.6250	0755-010-00	0755-210-00	0.10	XR-10A
0.7500	0755-012-00	0755-212-00	0.12	XR-12A
1.0000	0755-016-00	0755-216-00	0.26	XR-16A
1.2500	0755-020-00	0755-220-00	0.49	XR-20A
1.5000	0755-024-00	0755-224-00	0.75	XR-24A
2.0000	0755-032-00	0755-232-00	1.39	XR-32A

(Table 19)

- Consult factory for details and availability:  
Single seal versions 0755-1...-

(1) See page 71 for retaining ring dimensions

## Dimensions and Specifications



(Figure 6)

### Dimensions (inches)

Bore d	D	$C_{L(1)}$	$C_1$	$C_2$	$D_1$
.2500/.2495	0.5000	0.7500	0.5150	0.0390	0.4687
.3750/.3745	0.6250	0.8750	0.7030	0.0390	0.5880
.5000/.4995	0.8750	1.2500	1.0320	0.0459	0.8209
.6250/.6245	1.1250	1.5000	1.1120	0.0559	1.0590
.7500/.7495	1.2500	1.6250	1.2720	0.0559	1.1760
1.0000/.9995	1.5625	2.2500	1.8860	0.0679	1.4687
1.2500/1.2494	2.0000	2.6250	2.0110	0.0679	1.8859
1.5000/1.4994	2.3750	3.0000	2.4220	0.0859	2.2389
2.0000/1.9992	3.0000	4.0000	3.2060	0.1029	2.8379

(Table 20)

### Specifications

Nominal Shaft Diameter (in.)	Recommended Housing Bore <sup>(2)</sup>	Load Capacity <sup>(3)</sup>		No. of Ball Circuits
		dyn. C (lbf)	stat. $C_o$ (lbf)	
0.2500	0.5000 / 0.5005	60	80	4
0.3750	0.6250 / 0.6255	95	120	4
0.5000	0.8750 / 0.8755	230	290	4
0.6250	1.1250 / 1.1255	400	502	5
0.7500	1.2500 / 1.2505	470	592	6
1.0000	1.5625 / 1.5630	850	1062	6
1.2500	2.0000 / 2.0008	1230	1532	6
1.5000	2.3750 / 2.3760	1483	1852	6
2.0000	3.0000 / 3.0010	2430	3038	6

(Table 21)

#### Notes:

(1) Length tolerance -  
Bore size -

d 0.2500 - 0.3750	+ 0/ -0.015"
d 0.5000 - 1.0000	+ 0/ -0.020"
d 1.2500	+ 0/ -0.025"
d 1.5000	+ 0/ -0.030"
d 2.0000	+ 0/ -0.040"

(2) Transition fit

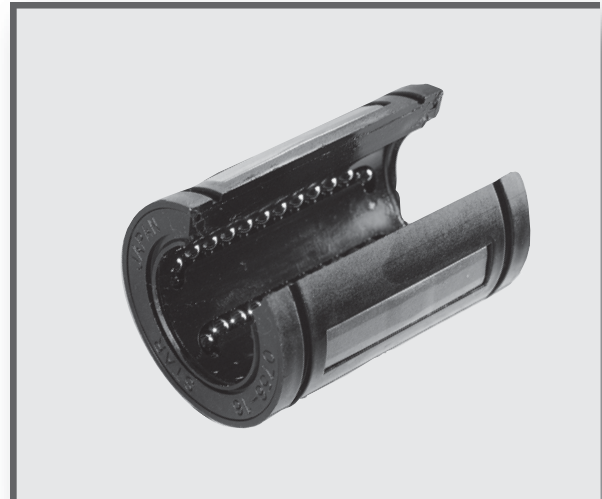
(3) See table 2 -page 7 for load  
correction factors

# Rexroth Super Linear Bushings

**Super Linear Bushing, 0756-**  
Open type - for use on supported shaft

## Structural design

- Lightweight resin retainer and outer sleeve
- Hardened and ground steel bearing load plates
- Balls made of high quality anti-friction bearing steel
- With or without integral seals
- Self-aligning to one degree inclusive



## Ordering Data

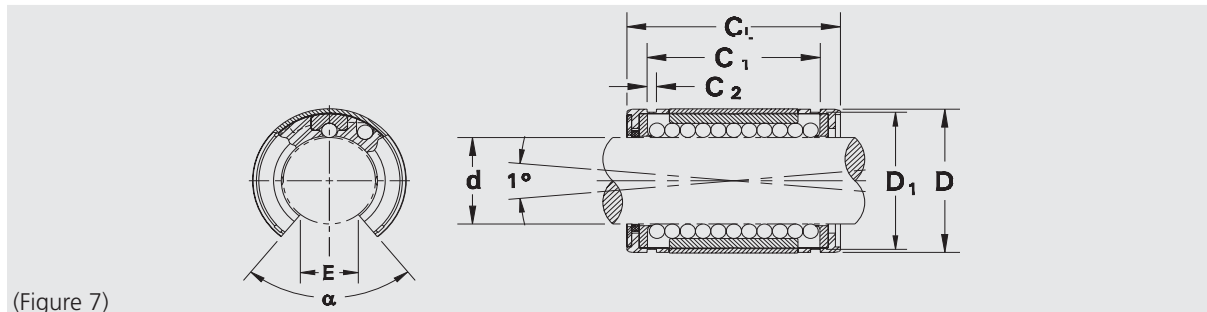
Nominal Shaft Diameter (in.)	Part Numbers		Mass (lb)	Corresponding External Retaining Ring <sup>(1)</sup>
	without seals	with two seals		
0.5000	0756-008-00	0756-208-00	0.03	XR-8A
0.6250	0756-010-00	0756-210-00	0.08	XR-10A
0.7500	0756-012-00	0756-212-00	0.10	XR-12A
1.0000	0756-016-00	0756-216-00	0.22	XR-16A
1.2500	0756-020-00	0756-220-00	0.40	XR-20A
1.5000	0756-024-00	0756-224-00	0.62	XR-24A
2.0000	0756-032-00	0756-232-00	1.15	XR-32A

(Table 22)

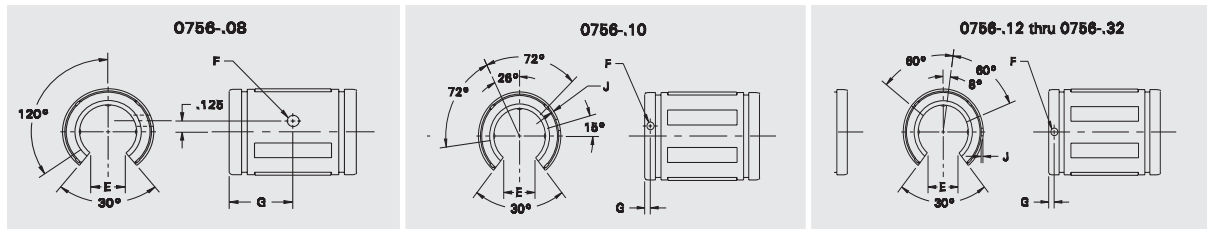
- Consult factory for details and availability:  
Single seal versions 0756-1...-

(1) See page 71 for retaining ring dimensions

## Dimensions and Specifications



(Figure 7)



(Figure 8)

(Figure 9)

(Figure 10)

### Dimensions (inches)

Bore d	D	$C_{L(1)}$	$C_1$	$C_2$	$D_1$	E	$\alpha$
.5000/.4995	0.8750	1.2500	1.0320	0.0459	0.8209	0.313	30°
.6250/.6245	1.1250	1.5000	1.1120	0.0559	1.0590	0.375	30°
.7500/.7495	1.2500	1.6250	1.2720	0.0559	1.1760	0.438	30°
1.0000/.9995	1.5625	2.2500	1.8860	0.0679	1.4687	0.563	30°
1.2500/1.2494	2.0000	2.6250	2.0110	0.0679	1.8859	0.625	30°
1.5000/1.4994	2.3750	3.0000	2.4220	0.0859	2.2389	0.750	30°
2.0000/1.9992	3.0000	4.0000	3.2060	0.1029	2.8379	1.000	

(Table 23)

### Specifications

Nominal Shaft Diameter (in.)	Recommended Housing Bore (2)	Load Capacity (3), (4)		No. of Ball Circuits
		dyn. C (lbf)	stat. $C_o$ (lbf)	
0.5000	0.8750 / 0.8755	230	290	3
0.6250	1.1250 / 1.1255	400	502	4
0.7500	1.2500 / 1.2505	470	592	5
1.0000	1.5625 / 1.5630	850	1062	5
1.2500	2.0000 / 2.0008	1230	1532	5
1.5000	2.3750 / 2.3760	1483	1852	5
2.0000	3.0000 / 3.0010	2430	3038	5

(Table 24)

Nominal Shaft Diameter (in.)	F Hole Dia.	J Depth
0.5000	0.136	Thru hole
0.6250	0.105	0.0390
0.7500	0.136	0.0590
1.0000	0.136	0.0470
1.2500	0.201	0.0900
1.5000	0.201	0.0900
2.0000	0.265	Thru hole

(Table 25)

Note: For notes 1, 2, and 3 refer to page 27  
 (4) 50 % derating required when load is applied through open side.

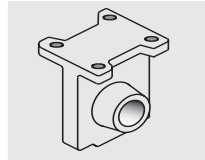
# Rexroth Linear Pillow Block Sets

## Pillow Block Sets - Overview

### Cast Iron Series

#### **Closed Type**

Standard type with fixed bore and self-aligning spherical sleeve.

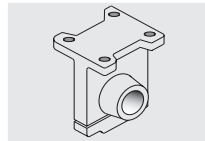


Page

32

#### **Adjustable Type**

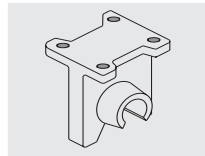
For use when zero clearance or preload is required.



34

#### **Open Type**

For use with long guideways when the shaft is fully supported.



36

### Aluminum Series

#### Single Sets

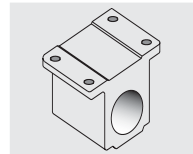
Page

#### Twin Sets

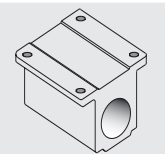
Page

#### **Closed Type**

Standard type with self-aligning insert used for high load.



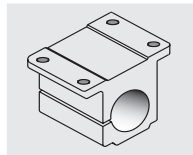
38



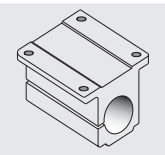
44

#### **Adjustable Type**

For use when zero clearance or preload is required.



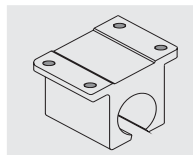
40



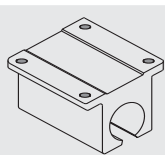
46

#### **Open Type**

For use with long guideways when the shaft is fully supported.



42



48

# Advantages

## Notes for Mounting

### High Load Capacity and Rigidity

Pillow Block Sets provide high rigidity regardless of the direction of load, even when the maximum load carrying capacities are achieved.

### Compact Block Design and Ease of Mounting the Aluminum Series

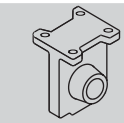
The Super Linear Bushing is completely enclosed in the compact housing to protect it against all external impacts. Pre-machined blocks provide accurate bore tolerance for smooth operation.

Mounting holes in the four corners provide rigid mounting to carriage assemblies.

Adjustable versions are available to achieve zero clearance assemblies.

### Vertical Dimensions

The tables for the Pillow Block Sets contain tolerance values for the height dimension "A". These tolerance values have been obtained by statistical methods and are representative of the values to be expected in actual practice.



### Cast Iron Pillow Block Sets

The Cast Iron series consists of three major components:

- 1) A rigid, high quality, one-piece cast iron block;
- 2) A precision, machined, spherical sleeve;
- 3) A sealed, pre-lubricated Linear Bushing.

All three series, closed, adjustable, and open, are adjusted to proper clearances at the factory. In addition, the integral spherical sleeve provides three degrees self-alignment in all directions.

### Aluminum Pillow Block Sets

The Super Pillow Block Sets combine the many benefits of the Super Linear Bushing with the simplicity of a rugged, lightweight mounting assembly.

The Super Pillow Block Set consists of:

- 1) A precision machined aluminum housing with lube ports;
- 2) A sealed, pre-lubricated Super Linear Bushing.

Note: Standard Linear Bushings may be used in some of the Aluminum Pillow Block Sets - contact the factory for details.

# Rexroth Linear Pillow Block Sets

## Cast Iron Pillow Block Set, 1750-

Closed type - for use on unsupported shaft

### Structural design

- Rigid cast iron block
- Self-aligning sleeve
- Standard bushing insert
- Fully sealed both ends



### Ordering Data

Nominal Shaft Diameter (in.)	Part Number	Mass (lb)
	with two seals	
0.5000	1750-208-00	0.50
0.7500	1750-212-00	1.30
1.0000	1750-216-00	2.10
1.2500	1750-220-00	4.40
1.5000	1750-224-00	5.70
2.0000	1750-232-00	10.50

(Table 26)

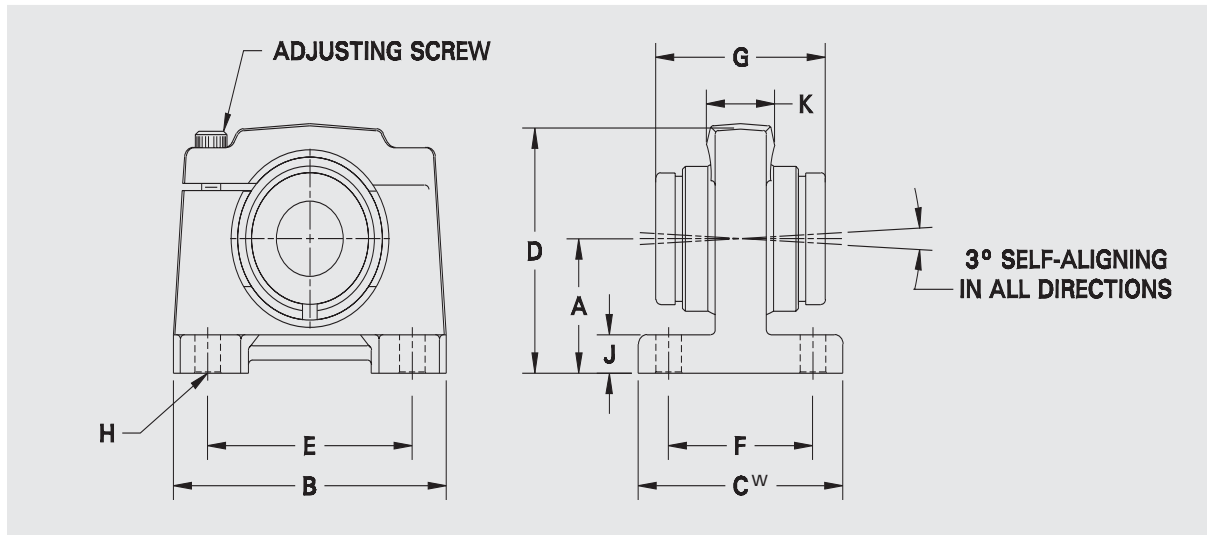
*Consult factory for details and availability:*

*No seal versions 1750-0..*

*Corrosion resistant series 1750-.-53*



## Dimensions and Specifications



(Figure 11)

### Dimensions (inches)

Nominal Shaft Diameter	A <sup>(1)</sup>	B	C <sub>w</sub>	D	E <sup>(2)</sup>	F <sup>(3)</sup>	G <sup>(4)</sup>	J	K
.5000	0.875	2.000	1.500	1.6250	1.500	1.000	1.250	0.2500	0.5000
.7500	1.125	2.750	2.000	2.1250	2.000	1.375	1.625	0.3125	0.6250
1.0000	1.375	3.250	2.250	2.5625	2.500	1.500	2.250	0.3750	1.0000
1.2500	1.750	4.000	2.750	3.2500	3.000	1.875	2.625	0.4375	1.2500
1.5000	2.000	4.750	3.000	3.7500	3.500	2.000	3.000	0.5000	1.4375
2.0000	2.500	6.000	3.500	4.7500	4.500	2.500	4.000	0.6250	1.6250

(Table 27)

### Specifications

Nominal Shaft Diameter (in.)	Load Capacity		No. of Ball Circuits	H Mounting Hole	
	dyn. C (lbf)	stat. C <sub>o</sub> (lbf)		Bolt	Hole
0.5000	115	176	4	#8	3/16
0.7500	194	308	5	#10	7/32
1.0000	221	353	6	1/4	9/32
1.2500	353	617	6	5/16	11/32
1.5000	491	905	6	5/16	11/32
2.0000	860	1787	6	3/8	13/32

(Table 28)

### Notes:

- (1) Center line tolerance +/- .005"
- (2) Bolt hole location tolerance +/- .010"
- (3) Bolt hole location tolerance +/- .010"
- (4) Bushing insert length tolerance  
Reference note 2 - page 19

# Rexroth Linear Pillow Block Sets

## Cast Iron Pillow Block Set, 1752-

Adjustable type - for use on unsupported shaft

### Structural design

- Rigid cast iron block
- Self-aligning sleeve
- Standard bushing insert
- Fully sealed both ends
- Adjustable bore



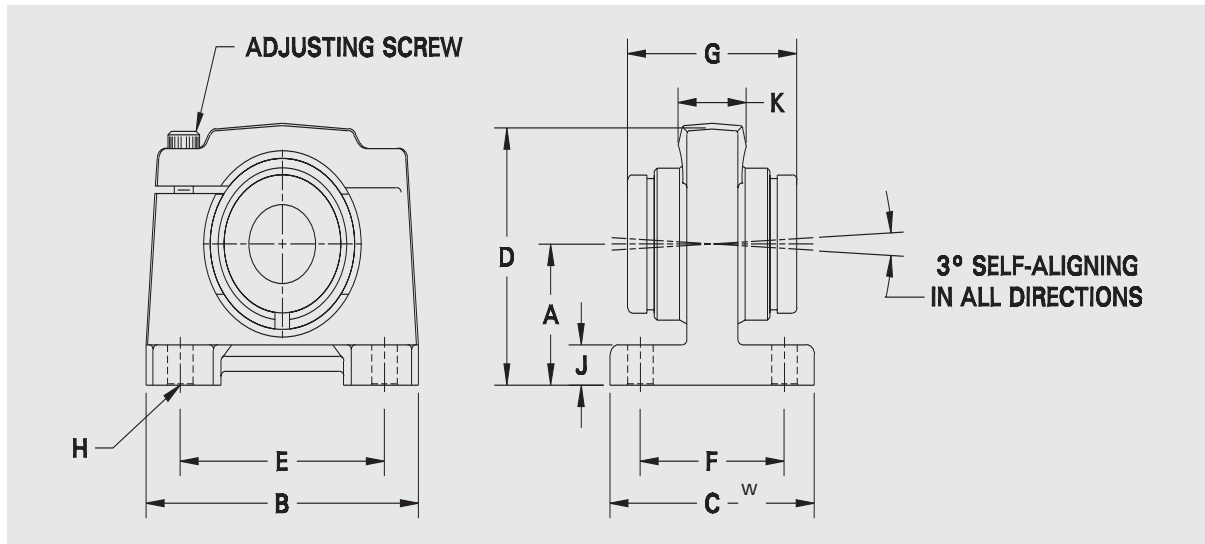
### Ordering Data

Nominal Shaft Diameter (in.)	Part Number	Mass (lb)
	with two seals	
0.5000	1752-208-00	0.50
0.7500	1752-212-00	1.30
1.0000	1752-216-00	2.10
1.2500	1752-220-00	4.40
1.5000	1752-224-00	5.70
2.0000	1752-232-00	10.50

(Table 29)

*Consult factory for details and availability:  
 No seal versions 1752-0..  
 Corrosion resistant series 1752-..-53*

## Dimensions and Specifications



(Figure 12)

### Dimensions (inches)

Nominal Shaft Diameter	A <sub>(1)</sub>	B	C <sub>w</sub>	D	E <sub>(2)</sub>	F <sub>(3)</sub>	G <sub>(4)</sub>	J	K
.5000	0.875	2.000	1.500	1.6250	1.500	1.000	1.250	0.2500	0.5000
.7500	1.125	2.750	2.000	2.1250	2.000	1.375	1.625	0.3125	0.6250
1.0000	1.375	3.250	2.250	2.5625	2.500	1.500	2.250	0.3750	1.0000
1.2500	1.750	4.000	2.750	3.2500	3.000	1.875	2.625	0.4375	1.2500
1.5000	2.000	4.750	3.000	3.7500	3.500	2.000	3.000	0.5000	1.4375
2.0000	2.500	6.000	3.500	4.7500	4.500	2.500	4.000	0.6250	1.6250

(Table 30)

### Specifications

Nominal Shaft Diameter (in.)	Load Capacity		No. of circuits	H Mounting Hole	
	dyn. C (lbf)	stat. C <sub>o</sub> (lbf)		Bolt	Hole
0.5000	115	176	4	#8	3/16
0.7500	194	308	5	#10	7/32
1.0000	221	353	6	1/4	9/32
1.2500	353	617	6	5/16	11/32
1.5000	491	905	6	5/16	11/32
2.0000	860	1787	6	3/8	13/32

(Table 31)

### Notes:

- (1) Center line tolerance +/- .005"
- (2) Bolt hole location tolerance +/- .010"
- (3) Bolt hole location tolerance +/- .010"
- (4) Bushing insert length tolerance  
Reference note 2 - page 19

# Rexroth Linear Pillow Block Sets

## Cast Iron Pillow Block Set, 1753- Open type - for use on supported shaft

### Structural design

- Rigid cast iron block
- Self-aligning sleeve
- Standard bushing insert
- Fully sealed both ends
- Adjustable open bore



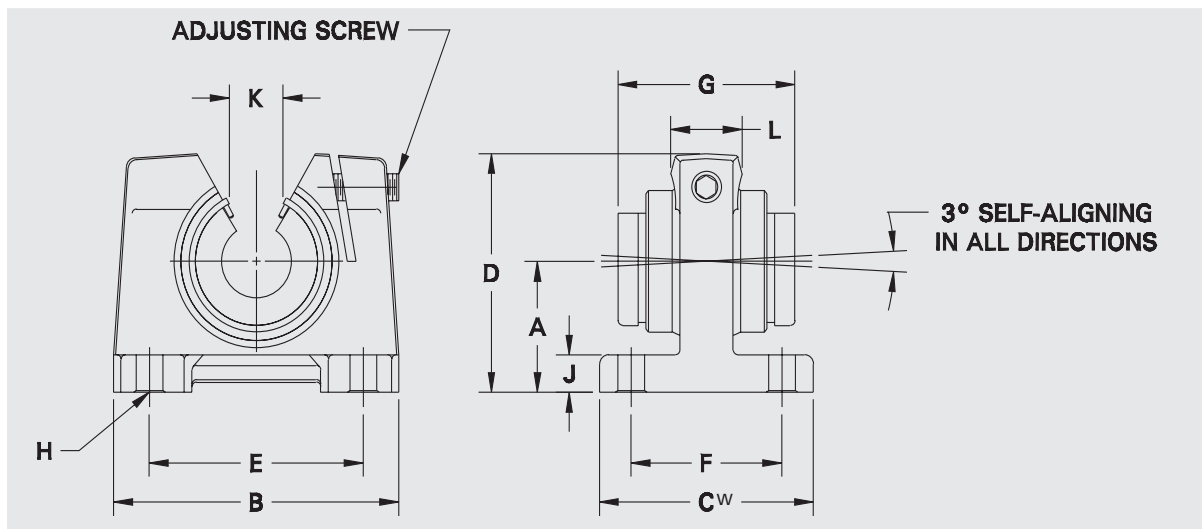
### Ordering Data

Nominal Shaft Diameter (in.)	Part Number	Mass (lb)
	with two seals	
0.5000	1753-208-00	0.50
0.7500	1753-212-00	1.30
1.0000	1753-216-00	2.10
1.5000	1753-224-00	5.70
2.0000	1753-232-00	10.50

(Table 32)

*Consult factory for details and availability:  
No seal versions 1753-0..  
Corrosion resistant series 1753-..-53*

## Dimensions and Specifications



(Figure 13)

### Dimensions (inches)

Nominal Shaft Diameter	A <sub>(1)</sub>	B	C <sub>w</sub>	D	E <sub>(2)</sub>	F <sub>(3)</sub>	G <sub>(4)</sub>	J	K
.5000	0.875	2.000	1.500	1.5938	1.500	1.000	1.250	0.2500	0.3125
.7500	1.125	2.750	2.000	2.0938	2.000	1.375	1.625	0.3125	0.4375
1.0000	1.375	3.250	2.250	2.5313	2.500	1.500	2.250	0.3750	0.5625
1.2500	1.750	4.000	2.750	3.2188	3.000	1.875	2.625	0.4375	0.6250
1.5000	2.000	4.750	3.000	3.7188	3.500	2.000	3.000	0.5000	0.7500
2.0000	2.500	6.000	3.500	4.6563	4.500	2.500	4.000	0.6250	1.0000

(Table 33)

### Specifications

Nominal Shaft Diameter (in.)	Load Capacity <sup>(5)</sup>		No. of circuits	H Mounting Hole		L
	dyn. C (lbf)	stat. C <sub>o</sub> (lbf)		Bolt	Hole	
0.5000	115	176	3	#8	3/16	15/32
0.7500	194	308	4	#10	7/32	19/32
1.0000	221	353	5	1/4	9/32	15/16
1.2500	353	617	5	5/16	11/32	1 5/32
1.5000	491	905	5	5/16	11/32	1 5/16
2.0000	860	1787	5	3/8	13/32	1 1/2

(Table 34)

### Notes:

- (1) Center line tolerance +/- .005"
- (2) Bolt hole location tolerance +/- .010"
- (3) Bolt hole location tolerance +/- .010"
- (4) Bushing insert length tolerance  
Reference note 2 - page 19
- (5) 50% derating required when load is applied through open side.

# Rexroth Linear Pillow Block Sets

## Aluminum Pillow Block Set, 1755-

Closed type - for use on unsupported shaft

### Structural design

- Precision, lightweight aluminum housing
- Super Linear Bushing insert
- Self-aligning feature
- Fully sealed both ends
- Access for lubrication



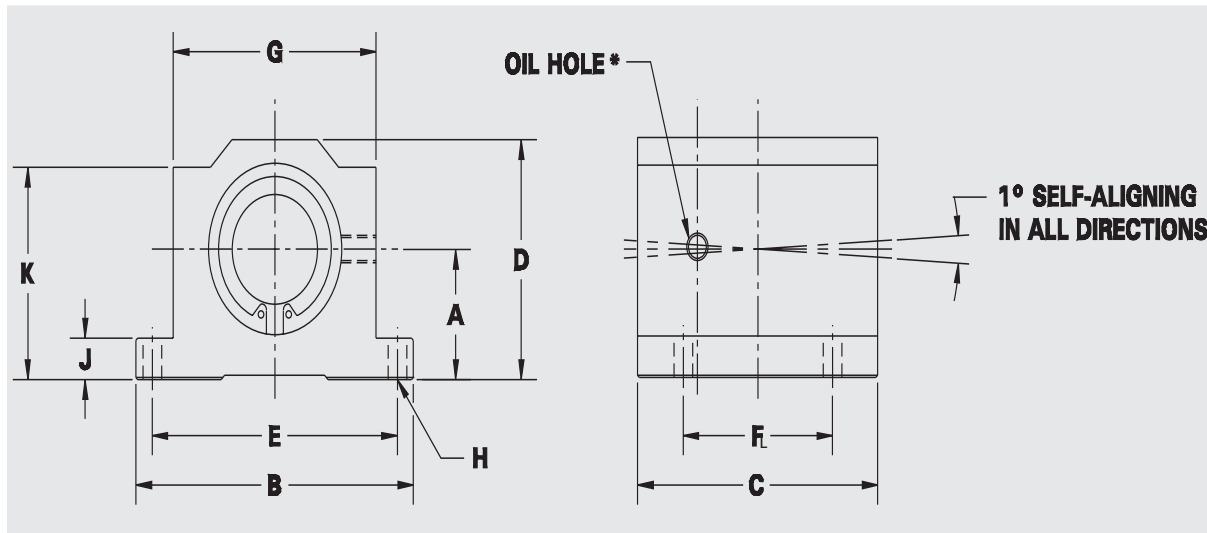
### Ordering Data

Nominal Shaft Diameter (in.)	Part Number	Mass (lb)
	with two seals	
0.2500	1755-704-00	0.09
0.3750	1755-706-00	0.12
0.5000	1755-708-00	0.24
0.6250	1755-710-00	0.47
0.7500	1755-712-00	0.57
1.0000	1755-716-00	1.18
1.2500	1755-720-00	2.40
1.5000	1755-724-00	3.50
2.0000	1755-732-00	6.90

(Table 35)

*Consult factory for details and availability:  
No seal versions 1755-0..*

## Dimensions and Specifications



(Figure 14)

### Dimensions (inches)

Nominal Shaft Diameter	A <sub>(1)</sub>	B	C <sub>L</sub>	D	E <sub>(2)</sub>	F <sub>(3)</sub>	G	J	K
0.2500	0.4370	1.625	1.188	0.813	1.312	0.750	1.000	0.188	0.750
0.3750	0.5000	1.750	1.313	0.938	1.437	0.875	1.125	0.188	0.875
0.5000	0.6870	2.000	1.688	1.250	1.688	1.000	1.375	0.250	1.125
0.6250	0.8750	2.500	1.938	1.625	2.125	1.125	1.750	0.281	1.437
0.7500	0.9370	2.750	2.063	1.750	2.375	1.250	1.875	0.313	1.563
1.0000	1.1870	3.250	2.813	2.188	2.875	1.750	2.375	0.375	1.938
1.2500	1.5000	4.000	3.625	2.813	3.500	2.000	3.000	0.438	2.500
1.5000	1.7500	4.750	4.000	3.250	4.125	2.500	3.500	0.500	2.875
2.0000	2.1250	6.000	5.000	4.063	5.250	3.250	4.500	0.625	3.625

(Table 36)

### Specifications

Nominal Shaft Diameter (in.)	Load Capacity		No. of Ball Circuits	H Mounting Hole		L
	dyn. C (lbf)	stat. C <sub>0</sub> (lbf)		Bolt	Hole	
0.2500	60	80	4	#6	5/32	0.394
0.3750	95	120	4	#6	5/32	0.433
0.5000	230	290	4	#6	5/32	0.591
0.6250	400	502	5	#8	3/16	0.709
0.7500	470	592	6	#8	3/16	0.717
1.0000	850	1062	6	#10	7/32	0.969
1.2500	1230	1532	6	#10	7/32	1.311
1.5000	1483	1852	6	1/4	9/32	1.378
2.0000	2430	3038	6	3/8	13/32	1.654

(Table 37)

### Notes:

- (1) Center line tolerance +/- .0012"
- (2) Bolt hole location tolerance +/- .010"
- (3) Bolt hole location tolerance +/- .010"

\* Provided with push-in oil fitting for sizes .2500" to .5000".  
 Sizes .6250" to 2" offer a 1/4 - 28 tapped hole with plug.

# Rexroth Linear Pillow Block Sets

## Aluminum Pillow Block Set, 1756-

Adjustable type - for use on unsupported shaft

### Structural design

- Precision, lightweight aluminum housing
- Super Linear Bushing insert
- Self-aligning feature
- Fully sealed both ends
- Adjustable bore
- Access for lubrication



### Ordering Data

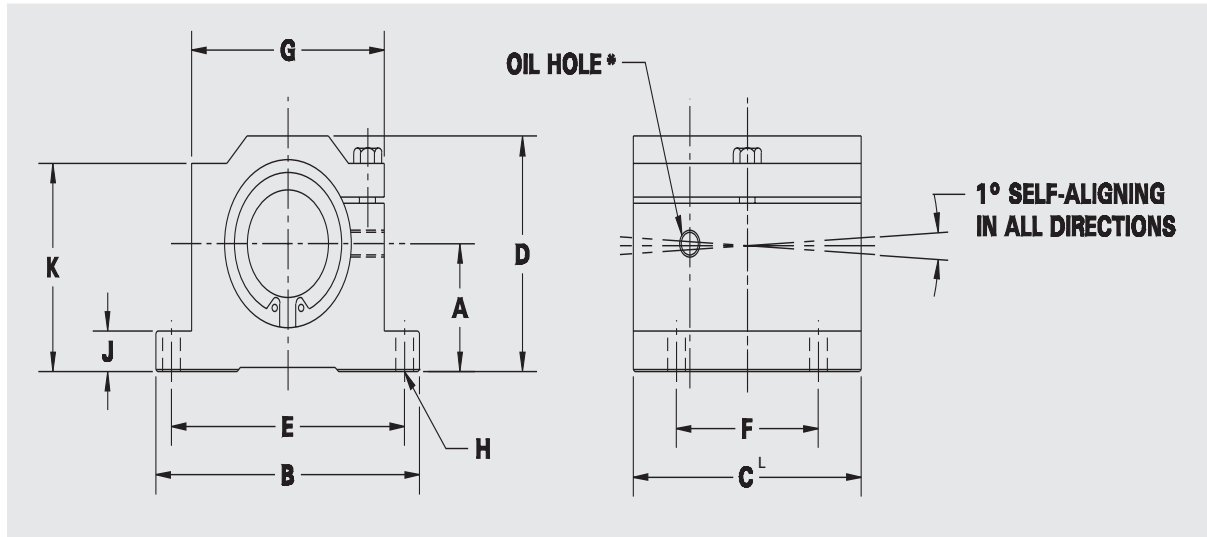
Nominal Shaft Diameter (in.)	Part Numbers	Mass (lb)
	with two seals	
0.2500	1756-704-00	0.09
0.3750	1756-706-00	0.12
0.5000	1756-708-00	0.24
0.6250	1756-710-00	0.47
0.7500	1756-712-00	0.57
1.0000	1756-716-00	1.18
1.2500	1756-720-00	2.40
1.5000	1756-724-00	3.50
2.0000	1756-732-00	6.90

(Table 38)

*Consult factory for details and availability:  
No seal versions 1756-0..*



## Dimensions and Specifications



(Figure 15)

### Dimensions (inches)

Nominal Shaft Diameter	A <sub>(1)</sub>	B	C <sub>L</sub>	D	E <sub>(2)</sub>	F <sub>(3)</sub>	G	J	K
0.2500	0.4370	1.625	1.188	0.813	1.312	0.750	1.000	0.188	0.750
0.3750	0.5000	1.750	1.313	0.938	1.437	0.875	1.125	0.188	0.875
0.5000	0.6870	2.000	1.688	1.250	1.688	1.000	1.375	0.250	1.125
0.6250	0.8750	2.500	1.938	1.625	2.125	1.125	1.750	0.281	1.437
0.7500	0.9370	2.750	2.063	1.750	2.375	1.250	1.875	0.313	1.563
1.0000	1.1870	3.250	2.813	2.188	2.875	1.750	2.375	0.375	1.938
1.2500	1.5000	4.000	3.625	2.813	3.500	2.000	3.000	0.438	2.500
1.5000	1.7500	4.750	4.000	3.250	4.125	2.500	3.500	0.500	2.875
2.0000	2.1250	6.000	5.000	4.063	5.250	3.250	4.500	0.625	3.625

(Table 39)

### Specifications

Nominal Shaft Diameter (in.)	Load Capacity		No. of Ball Circuits	H Mounting Hole		L
	dyn. C (lbf)	stat. C <sub>o</sub> (lbf)		Bolt	Hole	
0.2500	60	80	4	#6	5/32	0.394
0.3750	95	120	4	#6	5/32	0.433
0.5000	230	290	4	#6	5/32	0.591
0.6250	400	502	5	#8	3/16	0.709
0.7500	470	592	6	#8	3/16	0.717
1.0000	850	1062	6	#10	7/32	0.969
1.2500	1230	1532	6	#10	7/32	1.311
1.5000	1483	1852	6	1/4	9/32	1.378
2.0000	2430	3038	6	3/8	13/32	1.654

(Table 40)

#### Notes:

- (1) Center line tolerance +/- .0012"
- (2) Bolt hole location tolerance +/- .010"
- (3) Bolt hole location tolerance +/- .010"

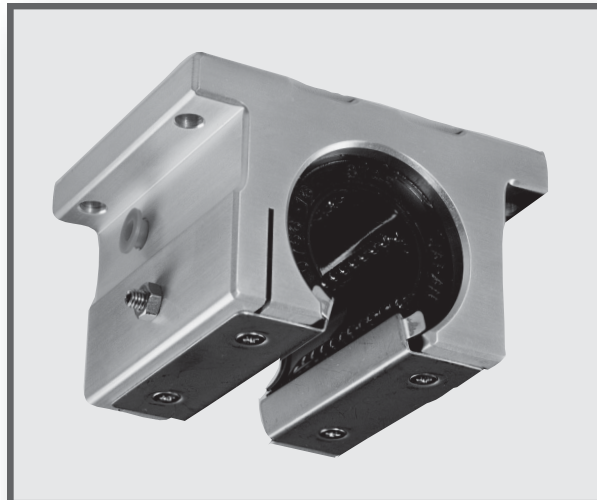
\* Provided with push-in oil fitting for sizes .2500" to .5000".  
 Sizes .6250" to 2" offer a 1/4 - 28 tapped hole with plug.

# Rexroth Linear Pillow Block Sets

## Aluminum Pillow Block Set, 1757- Open type - for use on supported shaft

### Structural design

- Precision, lightweight aluminum housing
- Super Linear Bushing insert
- Self-aligning feature
- Fully sealed both ends
- Adjustable open bore
- Access for lubrication



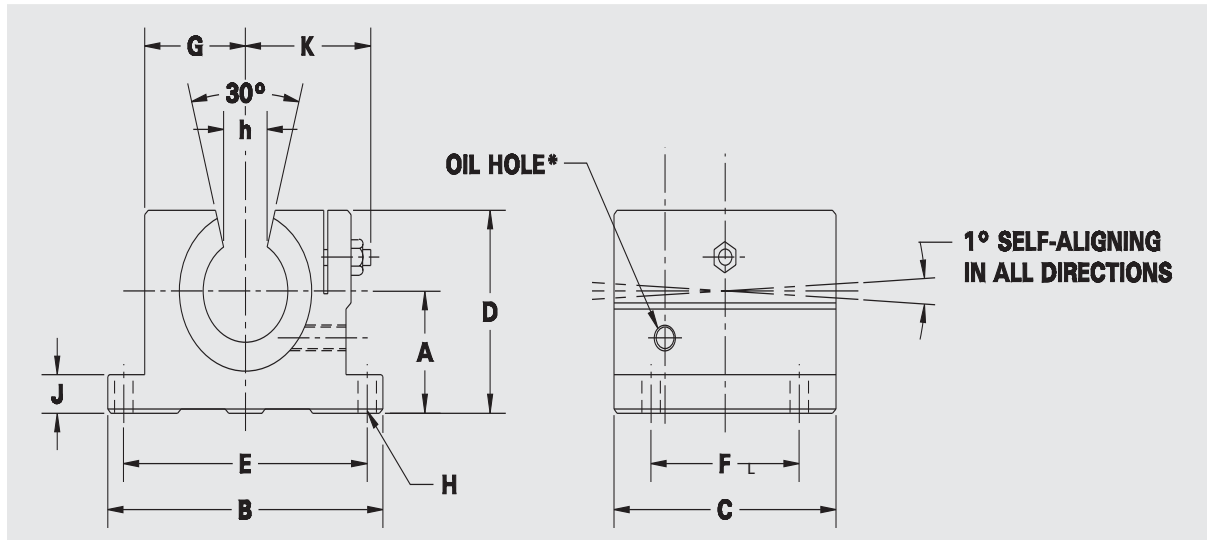
### Ordering Data

Nominal Shaft Diameter (in.)	Part Number	Mass (lb)
	with two seals	
0.5000	1757-708-00	0.19
0.6250	1757-710-00	0.37
0.7500	1757-712-00	0.50
1.0000	1757-716-00	1.07
1.2500	1757-720-00	2.04
1.5000	1757-724-00	3.07
2.0000	1757-732-00	5.92

(Table 41)

*Consult factory for details and availability:  
No seal versions 1757-0..*

## Dimensions and Specifications



(Figure 16)

### Dimensions (inches)

Nominal Shaft Diameter	A <sup>(1)</sup>	B	C <sub>L</sub>	D	E <sup>(2)</sup>	F <sup>(3)</sup>	G	J	K	h
0.5000	0.6870	2.000	1.500	1.100	1.688	1.000	0.688	0.250	0.905	0.260
0.6250	0.8750	2.500	1.750	1.405	2.125	1.125	0.875	0.281	1.095	0.319
0.7500	0.9370	2.750	1.875	1.535	2.375	1.250	0.937	0.315	1.161	0.386
1.0000	1.1870	3.250	2.625	1.975	2.875	1.750	1.188	0.375	1.457	0.512
1.2500	1.5000	4.000	3.375	2.485	3.500	2.000	1.500	0.437	1.831	0.569
1.5000	1.7500	4.750	3.750	2.910	4.125	2.500	1.750	0.500	2.087	0.681
2.0000	2.1250	6.000	4.750	3.660	5.250	3.250	2.250	0.625	2.638	0.933

(Table 42)

### Specifications

Nominal Shaft Diameter (in.)	Load Capacity		No. of Ball Circuits	H Mounting Hole		L
	dyn. C (lbf)	stat. C <sub>o</sub> (lbf)		Bolt	Hole	
0.5000	230	290	3	#6	5/32	0.980
0.6250	400	502	4	#8	3/16	1.070
0.7500	470	592	5	#8	3/16	1.150
1.0000	850	1062	5	#10	7/32	1.750
1.2500	1230	1532	5	#10	7/32	2.180
1.5000	1483	1852	5	1/4	9/32	2.500
2.0000	2430	3038	5	3/8	13/32	3.150

(Table 43)

### Notes:

- (1) Center line tolerance +/- .0012"
- (2) Bolt hole location tolerance +/- .010"
- (3) Bolt hole location tolerance +/- .010"

\* Provided with push-in oil fitting for size .5000". Sizes .6250" to 2.000" offer a 1/4 - 28 tapped hole with plug.

# Rexroth Linear Twin Pillow Block Sets

## Aluminum Twin Pillow Block Set, 1760-

Closed type - for use on unsupported shaft

### Structural design

- Precision, lightweight aluminum housing
- Twin style housing
- Two Super Linear Bushing inserts
- Self-aligning feature
- Fully sealed both ends
- Access for lubrication



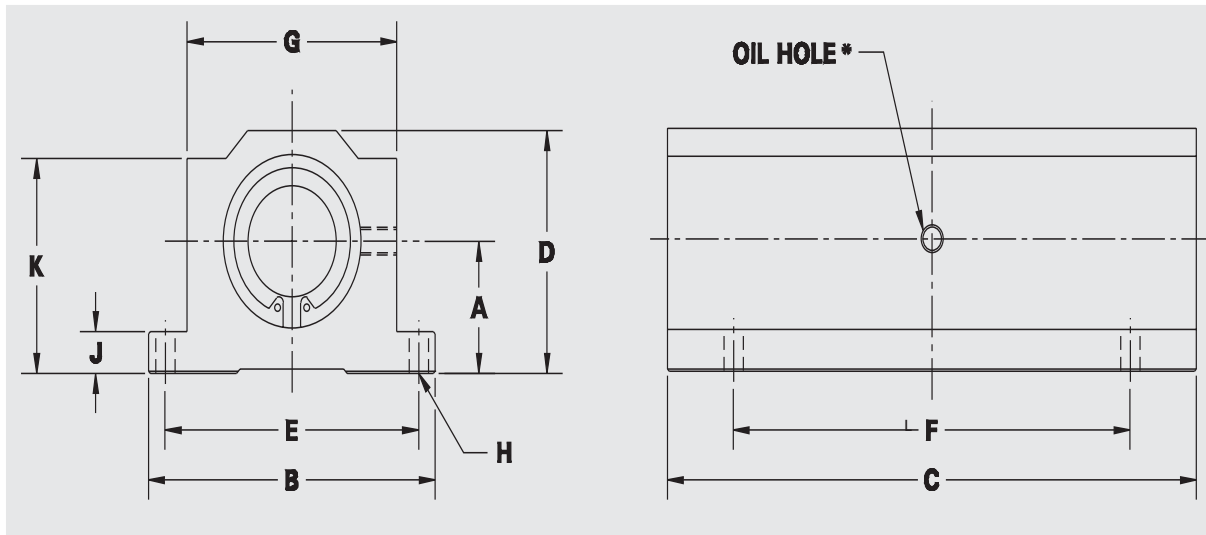
### Ordering Data

Nominal Shaft Diameter (in.)	Part Number	Mass (lb)
	with two seals	
0.2500	1760-704-00	0.19
0.3750	1760-706-00	0.24
0.5000	1760-708-00	0.49
0.6250	1760-710-00	0.96
0.7500	1760-712-00	1.25
1.0000	1760-716-00	2.50
1.2500	1760-720-00	5.00
1.5000	1760-724-00	7.80

(Table 44)

*Consult factory for details and availability:  
No seal versions 1760-0..*

## Dimensions and Specifications



(Figure 17)

### Dimensions (inches)

Nominal Shaft Diameter	A <sup>(1)</sup>	B	C <sub>L</sub>	D	E <sup>(2)</sup>	F <sup>(3)</sup>	G	J	K
0.2500	0.4370	1.625	2.500	0.813	1.312	2.000	1.000	0.188	0.750
0.3750	0.5000	1.750	2.750	0.938	1.437	2.250	1.125	0.188	0.875
0.5000	0.6870	2.000	3.500	1.250	1.688	2.500	1.375	0.250	1.125
0.6250	0.8750	2.500	4.000	1.625	2.125	3.000	1.750	0.281	1.437
0.7500	0.9370	2.750	4.500	1.750	2.375	3.500	1.875	0.313	1.563
1.0000	1.1870	3.250	6.000	2.188	2.875	4.500	2.375	0.375	1.938
1.2500	1.5000	4.000	7.500	2.813	3.500	5.500	3.000	0.438	2.500
1.5000	1.7500	4.750	9.000	3.250	4.125	6.500	3.500	0.500	2.875

(Table 45)

### Specifications

Nominal Shaft Diameter (in.)	Load Capacity		No. of Ball Circuits	H Mounting Hole	
	dyn. C (lbf)	stat. C <sub>o</sub> (lbf)		Bolt	Hole
0.2500	96	160	8	#6	5/32
0.3750	150	240	8	#6	5/32
0.5000	370	580	8	#6	5/32
0.6250	640	1000	10	#8	3/16
0.7500	750	1184	12	#8	3/16
1.0000	1360	2124	12	#10	7/32
1.2500	1925	3064	12	#10	7/32
1.5000	2360	3685	12	1/4	9/32

(Table 46)

### Notes:

- (1) Center line tolerance +/- .0012"
- (2) Bolt hole location tolerance +/- .010"
- (3) Bolt hole location tolerance +/- .010"

\* Provided with push-in oil fitting for sizes .2500" to .5000". Sizes .6250" to 1.500" offer a 1/4 - 28 tapped hole with plug.

# Rexroth Linear Twin Pillow Block Sets

## Aluminum Twin Pillow Block Set, 1762-

Adjustable type - for use on unsupported shaft

### Structural design

- Precision, lightweight aluminum housing
- Twin style housing
- Two Super Linear Bushing inserts
- Self-aligning feature
- Fully sealed both ends
- Adjustable bore
- Access for lubrication



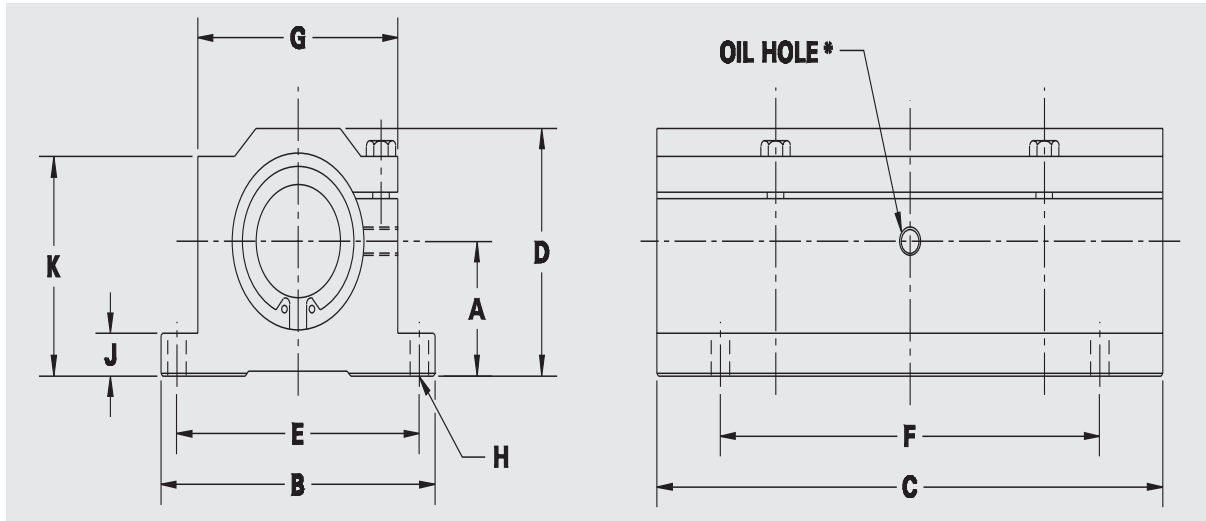
### Ordering Data

Nominal Shaft Diameter (in.)	Part Number	Mass (lb)
	with two seals	
0.2500	1762-704-00	0.19
0.3750	1762-706-00	0.25
0.5000	1762-708-00	0.50
0.6250	1762-710-00	0.96
0.7500	1762-712-00	1.25
1.0000	1762-716-00	2.50
1.2500	1762-720-00	5.00
1.5000	1762-724-00	7.80

(Table 47)

*Consult factory for details and availability:  
No seal versions 1762-0..*

## Dimensions and Specifications



(Figure 18)

### Dimensions (inches)

Nominal Shaft Diameter	A <sub>(1)</sub>	B	C <sub>L</sub>	D	E <sub>(2)</sub>	F <sub>(3)</sub>	G	J	K
0.2500	0.4370	1.625	2.500	0.813	1.312	2.000	1.000	0.188	0.750
0.3750	0.5000	1.750	2.750	0.938	1.437	2.250	1.125	0.188	0.875
0.5000	0.6870	2.000	3.500	1.250	1.688	2.500	1.375	0.250	1.125
0.6250	0.8750	2.500	4.000	1.625	2.125	3.000	1.750	0.281	1.437
0.7500	0.9370	2.750	4.500	1.750	2.375	3.500	1.875	0.313	1.563
1.0000	1.1870	3.250	6.000	2.188	2.875	4.500	2.375	0.375	1.938
1.2500	1.5000	4.000	7.500	2.813	3.500	5.500	3.000	0.438	2.500
1.5000	1.7500	4.750	9.000	3.250	4.125	6.500	3.500	0.500	2.875

(Table 48)

### Specifications

Nominal Shaft Diameter (in.)	Load Capacity		No. of Ball Circuits	H Mounting Hole	
	dyn. C (lbf)	stat. C <sub>o</sub> (lbf)		Bolt	Hole
0.2500	96	160	8	#6	5/32
0.3750	150	240	8	#6	5/32
0.5000	370	580	8	#6	5/32
0.6250	640	1000	10	#8	3/16
0.7500	750	1184	12	#8	3/16
1.0000	1360	2124	12	#10	7/32
1.2500	1925	3064	12	#10	7/32
1.5000	2360	3685	12	1/4	9/32

(Table 49)

### Notes:

- (1) Center line tolerance +/- .0012"
- (2) Bolt hole location tolerance +/- .010"
- (3) Bolt hole location tolerance +/- .010"

\* Provided with push-in oil fitting for sizes .2500" to .5000".  
 Sizes .6250" to 1.500" offer a 1/4 - 28 tapped hole with plug.

# Rexroth Linear Twin Pillow Block Sets

**Aluminum Twin Pillow Block Set, 1763-**  
Open type - for use on supported shaft

## Structural design

- precision, lightweight aluminum housing
- twin style housing
- two Super Linear Bushing inserts
- self-aligning feature
- fully sealed both ends
- adjustable open bore
- access for lubrication



## Ordering Data

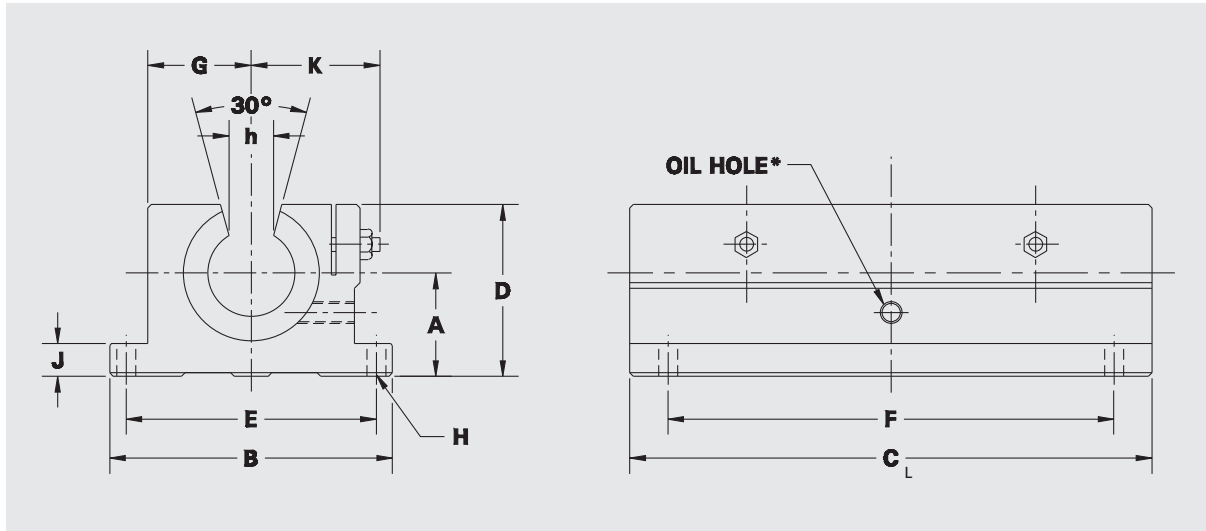
Nominal Shaft Diameter (in.)	Part Number	Mass (lb)
	with two seals	
0.5000	1763-708-00	0.40
0.6250	1763-710-00	0.80
0.7500	1763-712-00	1.00
1.0000	1763-716-00	2.00
1.2500	1763-720-00	4.20
1.5000	1763-724-00	6.70

(Table 50)

-Consult factory for details and availability:  
No seal versions 1763-0..



## Dimensions and Specifications



(Figure 19)

### Dimensions (inches)

Nominal Shaft Diameter	A <sup>(1)</sup>	B	C <sub>L</sub>	D	E <sup>(2)</sup>	F <sup>(3)</sup>	G	J	K	h
0.5000	0.6870	2.000	3.500	1.100	1.688	2.500	0.688	0.250	0.905	0.260
0.6250	0.8750	2.500	4.000	1.405	2.125	3.000	0.875	0.281	1.095	0.319
0.7500	0.9370	2.750	4.500	1.535	2.375	3.500	0.937	0.315	1.161	0.386
1.0000	1.1870	3.250	6.000	1.975	2.875	4.500	1.188	0.375	1.457	0.512
1.2500	1.5000	4.000	7.500	2.485	3.500	5.500	1.500	0.437	1.831	0.569
1.5000	1.7500	4.750	9.000	2.910	4.125	6.500	1.750	0.500	2.087	0.681

(Table 51)

### Specifications

Nominal Shaft Diameter (in.)	Load Capacity		No. of Ball Circuits	H Mounting Hole	
	dyn. C (lbf)	stat. C <sub>o</sub> (lbf)		Bolt	Hole
0.5000	370	580	6	#6	5/32
0.6250	640	1000	8	#8	3/16
0.7500	750	1184	10	#8	3/16
1.0000	1360	2124	10	#10	7/32
1.2500	1924	3064	10	#10	7/32
1.5000	2360	3685	10	1/4	9/32

(Table 52)

### Notes:

- (1) Center line tolerance +/- .0012"
- (2) Bolt hole location tolerance +/- .010"
- (3) Bolt hole location tolerance +/- .010"

\* Provided with push-in oil fitting for sizes .5000". Sizes .6250" to 1.500" offer a 1/4 - 28 tapped hole with plug.

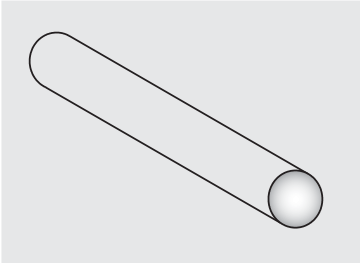
# Rexroth Precision Steel Shafts

## Shaft Products - Overview

### Precision Shafts

1700-..

Case hardened polished and ground shaft.. Carbon or stainless material used in end supported Linear Assemblies.



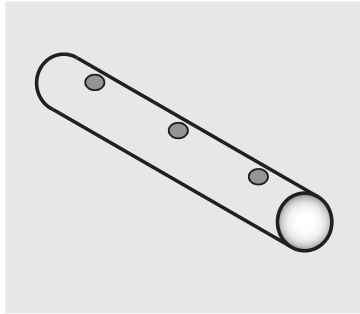
Page

55

### Predrilled Shafts

1771-..

Case hardened polished and ground shaft. Carbon or stainless material. Pre-drilled radial taps provide mounting capability when used with shaft support rails.

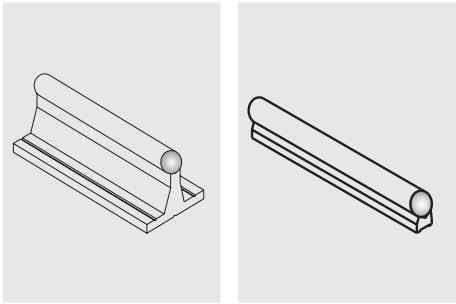


62

### Shaft Support Rail Assemblies

1769-../ 1770-..

Combination of predrilled shaft mounted to predrilled shaft support rails. Available with carbon or stainless shaft and aluminum shaft support rails. Continuous support to shaft over length of assembly.



65

## Precision Shaft

A critical component of the Linear Bushings Assembly is the shaft. Consideration for proper surface finish, hardness, and diameter is essential for performance of the assembly.

Rexroth Precision Steel Shafts are induction hardened and centerless ground to ensure quality fit and performance, complimenting the Linear Bushing line of Rexroth products.

In addition to the shaft acting as guideways with Linear Bushings, they also have a long and successful service in the following applications:

- Guide rods
- Control rods
- Rollers
- Pistons
- Axles
- Guide pins
- Tie rods
- Spindles
- Guide columns
- Mandrels and other similar applications

### **Precision Shafts offer the following features:**

- Diameter range between 1/4" to 4" nominal diameter
- Class L and S O.D. tolerances
- Carbon steel and stainless steel materials
- Random lengths up to 244" long
- Plain and predrilled shaft material
- Case hardened to R<sub>c</sub>60-64

# Rexroth Precision Steel Shafts

## Technical Data

### Dimensional accuracy and tolerance zones

The diameters of inch Precision Steel Shafts are accurate to within the tolerance zones of Classes L and S. Details on the dimensional accuracy of these shafts are compiled in the table on the right. The tolerance for the diameter of soft-annealed shaft sections may be greater than the tolerance zones quoted.

For special diameter tolerances, please contact the factory.

### Straightness

Because of the length of the shafts, it would be uneconomical to use the straightness measurement method specified in DIN ISO 1101 section 14.1. Instead of direct measurement for straightness, the shafts are tested for runout tolerance as described in DIN ISO 1101 section 14.13.1. See "Measurement of straightness".

### Tolerances for inch-size steel shafts

Nominal diameter	(in)	over up to	0	1/4	3/8	5/8	1	2	3
			1/4	3/8	5/8	1	2	3	4
Roundness	L	(in)	.00025	.00015	.00020	.00024	.00028	.00032	.00039
	S	(in)	.00020	.00024	.00032	.00035	.00043	.00051	.00059
Taper, Convexity, Concavity	L	(in)	.00020	.00024	.00032	.00035	.00043	.00051	.00059
	S	(in)	.00032	.00035	.00043	.00051	.00063	.00075	.00087
Straightness		(in/ft)	.0015	.0015	.0015	.0015	.0015	.0015	.0015
Measured value $t_1^{1)}$		(in/ft)	.0047	.0047	.0047	.0047	.0047	.0047	.0047
Surface roughness maximum (RA) <sup>2)</sup>		( $\mu\text{in}$ )	13	13	13	13	13	13	13

(Table 59)

<sup>1)</sup> Dial gauge reading during straightness measurement. For lengths of less than 303 ft., the lowest possible value is .0015in. This corresponds to a straightness tolerance of .0008 in.

<sup>2)</sup> Applies to shafts made of heat-treatable or anti-friction bearing steel only. Please contact us for surface finish and surface roughness (RA) tolerances for corrosion-resistant steel shafts.

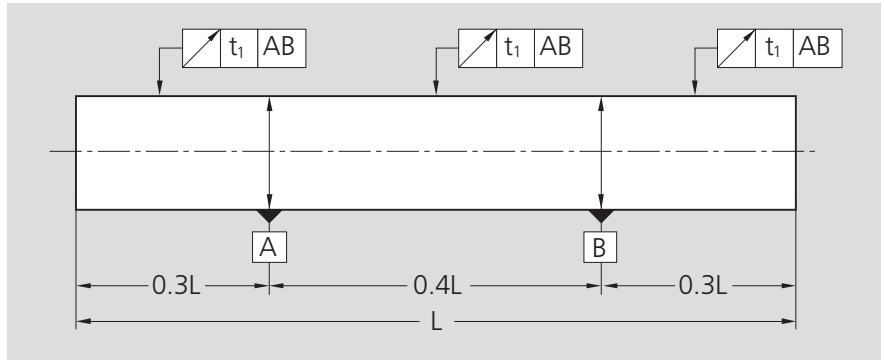
Shaft Ø d		Class "L"		Class "S" <sup>3)</sup>	
(Inch)	(mm)	(Inch)	(mm)	(Inch)	(mm)
1/4	6.35	-0.0005 -0.0010	-0.013 -0.025	-0.0010 -0.0015	-0.025 -0.038
3/8	9.525	-0.0005 -0.0010	-0.013 -0.025	-0.0010 -0.0015	-0.025 -0.038
1/2	12.70	-0.0005 -0.0010	-0.013 -0.025	-0.0010 -0.0015	-0.025 -0.038
5/8	15.875	-0.0005 -0.0010	-0.013 -0.025	-0.0010 -0.0015	-0.025 -0.038
3/4	19.05	-0.0005 -0.0010	-0.013 -0.025	-0.0010 -0.0015	-0.025 -0.038
1	25.40	-0.0005 -0.0010	-0.013 -0.025	-0.0010 -0.0015	-0.025 -0.038
1 1/4	31.75	-0.0005 -0.0010	-0.013 -0.025	-0.0010 -0.0015	-0.025 -0.038
1 1/2	38.1	-0.0006 -0.0011	-0.015 -0.028	-0.0011 -0.0016	-0.028 -0.041
2	50.8	-0.0006 -0.0013	-0.015 -0.033	-0.0013 -0.0020	-0.033 -0.051
3	76.2	-0.008 -0.0017	-0.020 -0.043	-0.0017 -0.0026	-0.043 -0.066
4	101.6	-0.0012 -0.0024	-0.030 -0.061	-0.0024 -0.0036	-0.061 -0.091

<sup>3)</sup> Class "S" by special request only.

(Table 60)

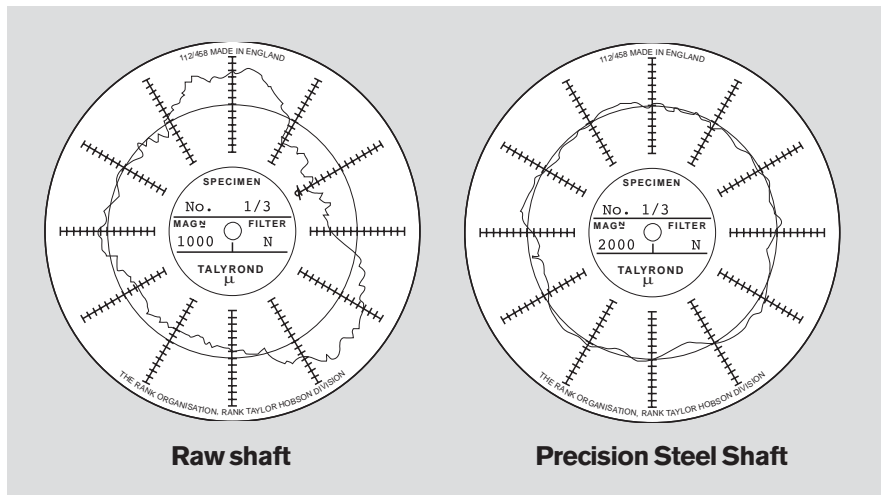
### Measurement of straightness

Measurements are performed at points equidistant between the support points and the overhanging ends of the shaft. The measured values are then halved and the resulting value  $t_1$  gives the straightness.



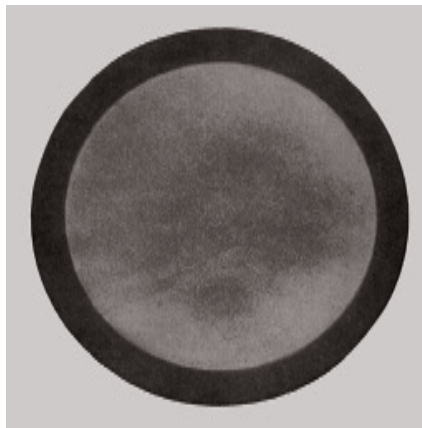
### Measurement of roundness

The figure shows the roundness of a raw shaft compared with that of a finished Precision Steel Shaft.



### Shaft hardness

The surface of the shaft is induction-hardened to a depth of at least 0.015 up to 0.125 inches, depending on the shaft diameter. Surface hardness and depth of hardness are extremely uniform, both in the axial and in the circumferential direction. This is the reason for the excellent dimensional consistency and the long service life of Precision Steel Shafts.



The photographs opposite show a longitudinal and a transverse section through a hardened and ground Precision Steel Shaft. The hardened surface zone has been made visible by caustic etching.

Shaft $\varnothing$ d	(in)	over	3/8	3/8	5/8	1	2	3
		up to	3/8	5/8	1	2	3	4
Depth of hardness <sup>1</sup>	(in)	min.	0.019	0.027	0.043	0.059	0.086	0.125

(Table 61)

<sup>1</sup> Please contact us to obtain the depth of hardness for corrosion-resistant steel shafts.

# Rexroth Precision Steel Shafts

## Technical Data

Minimum hardness Solid and tubular shafts HRC 60 Corrosion-resistant steel shafts HRC 53 to DIN 17230 / EN 10088

The figure opposite shows the microstructure in the surface zone of a shaft cross section (magnification approx. 10x). The hardened outer layer of martensite and the smooth transition to the tough inner core structure are clearly visible.



Induction-hardened surface zone  
Structure: martensite  
hardness • HRC 60 (Rockwell C)

Transitional structure:  
martensite  
troostite  
pearlite

Core structure:  
pearlite and ferrite

## Shaft deflection

When steel shafts are used as linear motion guideways for linear bushings it is important that the shaft deflection occurring under load is kept within certain limits, as otherwise the proper functioning and the service life of the assembly could be impaired<sup>1</sup>. To facilitate the determination of shaft deflection by calculation, we have compiled the most common load cases together with the associated deflection equations in the table below. The equations for calculation of the inclination of the shaft in the linear bushing ( $\tan \alpha$ ) can also be taken from this table.

Case No.	Loading conditions	Deflection equation	Shaft inclination in linear bushings
1		$f_1 = \frac{F \cdot a^3}{6 \cdot E \cdot J} \cdot \left(2 - \frac{3 \cdot b}{l}\right)$ $f_{m1} = \frac{F \cdot a^2}{24 \cdot E \cdot J} \cdot (3l - 4a)$	$\tan \alpha_{(x=a)} = \frac{F \cdot a^2 \cdot b}{2 \cdot E \cdot J \cdot l}$
2		$f_2 = \frac{F \cdot l^3}{2 \cdot E \cdot J} \cdot \frac{a^2}{l^2} \cdot \left(1 - \frac{4}{3} \cdot \frac{a}{l}\right)$ $f_{m2} = \frac{F \cdot l^3}{8 \cdot E \cdot J} \cdot \frac{a}{l} \cdot \left(1 - \frac{4}{3} \cdot \frac{a^2}{l^2}\right)$	$\tan \alpha_{(x=a)} = \frac{F \cdot a \cdot b}{2 \cdot E \cdot J}$
3		$f_3 = \frac{F \cdot l^3}{3 \cdot E \cdot J} \cdot \frac{a^3 \cdot b^3}{l^3 \cdot l^3}$ $f_{m3} = \frac{2 \cdot F \cdot l^3}{3 \cdot E \cdot J} \cdot \frac{a^3}{l^3} \cdot \frac{b^2}{l^2} \cdot \left(\frac{l}{l+2a}\right)^2$	$\tan \alpha_{(x=b)} = \frac{F \cdot a^2 \cdot b^2}{2 \cdot E \cdot J \cdot l^2} \cdot \left(1 - \frac{2 \cdot b}{l}\right)$
4		$f_4 = \frac{F \cdot l^3}{3 \cdot E \cdot J} \cdot \frac{a^2 \cdot b^2}{l^2 \cdot l^2}$ $f_{m4} = f_4 \cdot \frac{l+b}{3 \cdot b} \cdot \sqrt{\frac{l+b}{3 \cdot a}}$	$\tan \alpha_{(x=b)} = \frac{F \cdot a}{6 \cdot E \cdot J \cdot l} \cdot (3b^2 - l^2 + a^2)$
5		$f_5 = \frac{5 \cdot F \cdot l^3}{384 \cdot E \cdot J}$	$\tan \alpha_{(x=0)} = \frac{F \cdot l^2}{24 \cdot E \cdot J}$

(Table 62)

<sup>1</sup> There will be no loss of load-carrying capacity or service life in Super Linear Bushings provided the shaft deflection does not exceed 30' ( $\tan 30' = 0.0087$ ).

The tables below give the values for the maximum permissible shaft inclination ( $\tan \alpha_{\max}$ ) for each size of Standard Linear Bushing.

At  $\tan \alpha = \tan \alpha_{\max}$  the permissible static load capacity is approx.  $0.4 C_O$ .

Shaft Ø d (in.)	$\tan \alpha_{\max}$
1/4	$12.3 \cdot 10^{-4}$
3/8	$10.0 \cdot 10^{-4}$
1/2	$10.1 \cdot 10^{-4}$
5/8	$8.5 \cdot 10^{-4}$
3/4	$8.5 \cdot 10^{-4}$
1	$7.2 \cdot 10^{-4}$

(Table 63)

Shaft Ø d (in.)	$\tan \alpha_{\max}$
1 1/4	$6.4 \cdot 10^{-4}$
1 1/2	$7.3 \cdot 10^{-4}$
2	$6.3 \cdot 10^{-4}$
3	$5.7 \cdot 10^{-4}$
4	$5.7 \cdot 10^{-4}$

(Table 64)

#### Values for E x J and mass for steel shafts

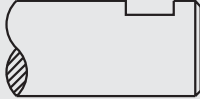







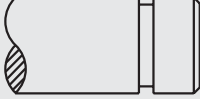

Solid shafts			
Ø d		E x J	Mass
(Inches)	(mm)	(lb x in <sup>2</sup> )	(lb/in)
1/4	6.35	$1.16 \times 10^5$	0.014
3/8	9.525	$5.85 \times 10^5$	0.031
1/2	12.7	$1.85 \times 10^6$	0.056
5/8	15.875	$4.51 \times 10^6$	0.087
3/4	19.05	$9.38 \times 10^6$	0.125
1	25.4	$2.96 \times 10^7$	0.223
1 1/4	31.75	$7.25 \times 10^7$	0.348
1 1/2	38.1	$1.50 \times 10^8$	0.501
2	50.8	$4.74 \times 10^8$	0.890
2 1/2	63.5	$1.16 \times 10^9$	1.391
3	76.2	$2.40 \times 10^9$	2.003
4	101.6	$7.59 \times 10^9$	3.560

(Table 65)

# Rexroth Precision Steel Shafts

## Machining

Examples of standard shaft machining services available are illustrated below. Many custom features can also be provided. A print or sketch must be provided to Bosch Rexroth indicating all dimensions, tolerances and the quantity required.

Standard Machining Options:		Standard Machining Options	Rexroth Tolerance		
		Three-place decimal Two-place decimal One-place decimal	+0.005" +0.010" +0.020"		
Flat				Keyway	
					
Tapped Hole	Radial Hole			Threaded End	
					
Coaxial Hole	Retaining Ring Groove			Reduced End	

When no tolerances are specified, Bosch Rexroth will apply the following standard tolerances based upon the range of precision indicated by the blueprint.

Example	
<u>Blueprint Dimensions</u>	<u>Tolerance</u>
.XXX -three place decimal	+/- .005"
.XX -two place decimal	+/- .010"
.X -one place decimal	+/- .020"



## Series 1700-0XX Precision Steel Shaft Specifications

- Materials: --Ck55 or C55 carbon steel (similar to AISI C-1055), case hardened to min. R<sub>c</sub>60 to 64  
Case depth shown in table 66.  
--X46Cr13 stainless steel (similar to AISI 430C), case hardened to min. R<sub>c</sub>53.  
Case depth shown in table 66.
- Surface finish: 8 to 13 RA microinches
- Length tolerances: +/- 1/32" for shafts up to 1.25" in diameter  
+/- 1/16" for shafts up to 1.5" in diameter and over  
\* closer tolerances are available at additional costs
- Straightness tolerance: .0015" per foot
- End Conditions: Shaft ends are chamfered approximately 1/32" X 45° up to 1.25" diameter shaft and 1/16" X 45° to 1.5" diameter and up. Other chamfers can be provided at additional costs.

### Shaft Selection Table

Nominal Shaft Diameter (in.)	Part Numbers <sup>(1)</sup> Class L -08 Class S -09	Actual Diameter		Weight lb/in	*Random Length (Avg.)	Case Depth (min.)
		Class L	Class S			
1/4	1700-004-08 / 09	.2495/.2490	.2490/.2485	0.014	244"	0.019
3/8	1700-006-08 / 09	.3745/.3740	.3740/.3735	0.031	244"	0.027
1/2	1700-008-08 / 09	.4995/.4990	.4990/.4985	0.056	244"	0.031
5/8	1700-010-08 / 09	.6245/.6240	.6240/.6235	0.087	244"	0.043
3/4	1700-012-08 / 09	.7495/.7490	.7490/.7485	0.125	244"	0.047
1	1700-016-08 / 09	.9995/.9990	.9990/.9985	0.223	244"	0.059
1 1/4	1700-020-08 / 09	1.2495/1.2490	1.2490/1.2485	0.348	244"	0.059
1 1/2	1700-024-08 / 09	1.4994/1.4989	1.4989/1.4984	0.501	244"	0.062
2	1700-032-08 / 09	1.9994/1.9987	1.9987/1.9980	0.890	244"	0.086
2 1/2	1700-040-08 / 09	2.4993/2.4985	2.4985/2.4977	1.391	244"	0.086
3	1700-048-08 / 09	2.9992/2.9983	2.9983/2.9974	2.003	208"	0.086
4	1700-064-08 / 09	3.9988/3.9976	3.9976/3.9964	3.560	208"	0.110

(Table 66)

\*Consult Bosch Rexroth for details on longer lengths

(1)Stainless Steel Shaft: For Stainless Steel Shaft Class L use suffix -28  
For Stainless Steel Shaft Class S use suffix -29

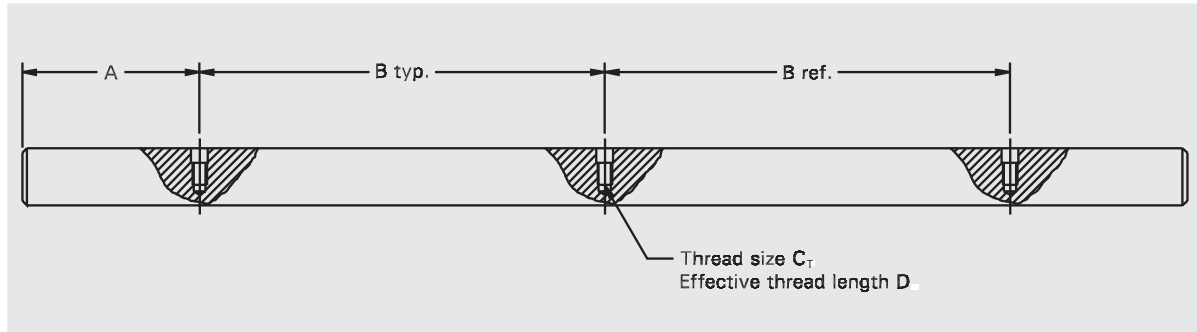
Order Example:

**Part Number ---- 1700-004-08,48"**

material ---- Standard carbon steel  
diameter ---- 1/4" nominal

# Rexroth Precision Steel Shafts

## Series 1771-0XX Pre-drilled Shaft Specifications



(Figure 23)

### Shaft Selection Table

(Old Series 1700-5..)

Nominal Shaft Diameter (in.)	Part Numbers <sup>(1)</sup>		A +/- 0.005	B +/- 0.010	*Random Lengths (Avg.)	C <sub>T</sub> Size	D Depth
	Carbon Steel CK-55 Class L	Stainless Steel x 46 Class L					
1/2	1771-008-08	1771-008-28	2.00	4.00	200"	#6-32	0.250
5/8	1771-010-08	1771-010-28	2.00	4.00	200"	#8-32	0.320
3/4	1771-012-08	1771-012-28	3.00	6.00	200"	#10-32	0.380
1	1771-016-08	1771-016-28	3.00	6.00	200"	1/4-20	0.500
1 1/4	1771-020-08	1771-020-28	3.00	6.00	200"	5/16-18	0.630
1 1/2	1771-024-08	1771-024-28	4.00	8.00	200"	3/8-16	0.750
2	1771-032-08	1771-032-28	4.00	8.00	200"	1/2-13	1.000

(Table 67)

\*Consult Bosch Rexroth for details on longer lengths  
 (1) For Class S Shaft use suffix -09  
 For Stainless Steel Shaft Class S use suffix -29

Materials: Ck-55 carbon steel (similar to AISI C-1055), case hardened to R<sub>c</sub>60 to 64  
 X 46 Cr13 stainless steel (similar to AISI 440C), case hardened to R<sub>c</sub>52 to 56.

Surface finish: 8 to 13 RA microinches

Length tolerances: +/- 1/32" for shafts up to 1.25" in diameter  
 +/- 1/16" for shafts up to 1.5" in diameter and over

Straightness tolerance: .0015" per foot

#### Order Example:

**Part Number ---- 1771-012-08,144"**

material----Standard carbon steel

diameter----3/4" nominal

Tolerance----Class L diameter

Length----144" long

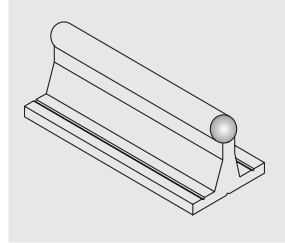
# Rexroth Shaft Support Rail Assemblies

## Shaft Support Rail Assemblies - Overview

### High Profile Assembly

**1769-0..**

Flange style shaft support rail available plain or predrilled. Provides support to shaft assemblies where deflection is a concern.



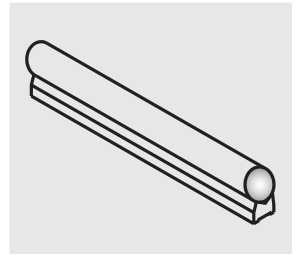
Page

60

### Low Profile Assembly

**1770-0..**

Low profile shaft support rail available in plain or predrilled. Provide a rigid support and a lower center of gravity for shaft assemblies.



61

Shaft support assemblies are designed to provide a rigid structure and eliminate shafts bending under load. The Rexroth Shaft Support Rail Assemblies are delivered in ready mount from sections.

The basic design consists of Rexroth Precision Shaft and Support Rails. Various shaft diameters and materials are available for whatever design requirements are necessary.

### Advantages

- Prevent shaft deflection
- Ensure efficient running of linear motion assemblies
- Eliminate the need for time consuming and costly designs

Continuous support of the shaft is possible by assembling individual supports end to end underneath the corresponding shaft. This ensures complete and uninterrupted support along the entire assembly.

Support assemblies are sized 1/2" nominal shaft diameter to 2" nominal shaft diameter in standard lengths up to 200" long.

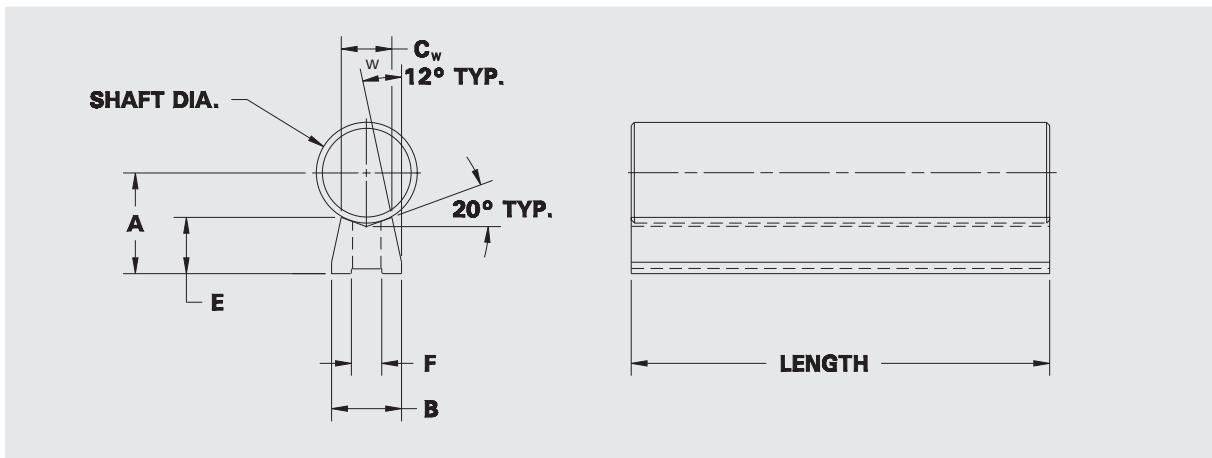
Other lengths and modifications may be made to the shaft/rail assemblies at additional costs. A print or sketch is required for quotation.



# Rexroth Shaft Support Rail Assemblies

## Series 1770-0XX Low Profile Shaft Support Assembly

Specifications:	Materials:	Support rails: AISI 1018 Steel Shaft: CK-55 carbon steel / X46 Cr13 stainless steel
	Surface Finish:	Support rail: Steel mill finish Shaft: 8 to 13 RA micro inches
	Base hole location:	+/- .005" non-cumulative



(Figure 25)

### Support Rail Assembly Selection Table

(Old Series 1700-6XX-37)

Nominal Shaft Diameter (in.)	Shaft/Rail Assembly Part Number <sup>(1)</sup> Carbon Steel Cf-60 Class L	A +/-0.002	B +/-0.010	C <sub>w</sub> +/-0.010	E Ref.	F		Part Number for Rail Support <sup>(2)</sup>
						Bolt	Hole	
1/2	1770-008-08	0.562	0.370	0.250	0.341	6-32	0.169	1768-108-00
3/4	1770-012-08	0.750	0.510	0.375	0.420	10-32	0.221	1768-112-00
1	1770-016-08	1.000	0.690	0.500	0.560	1/4-20	0.281	1768-116-00

(Table 69)

Note:

- (1) For Class S shaft use suffix -09  
For Stainless Steel shaft use suffix -2X
- (2) See page 69 for specification on Rail Supports

Order Example:

**Part Number ---- 1770-016-08,120"**

material----Standard carbon steel  
diameter----1" nominal class L  
Support Rail mounted to shaft  
Length----120" long

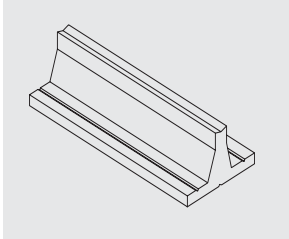
# Rexroth Shaft Support Rails

## Shaft Support Rail Products- Overview

Page

### High Profile Rails 1767-1../ 1767-0..

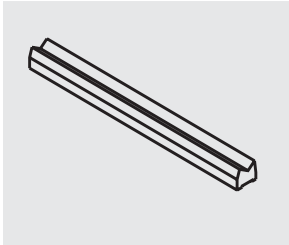
Flange style shaft support rail available plain or predrilled. Provides support to shaft assemblies where deflection is a concern.



63

### Low Profile Rails 1768-1../ 1768-0..

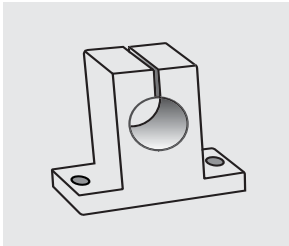
Low profile shaft support rail available in plain or predrilled. Provide a rigid support and a lower center of gravity for shaft assemblies.



64

### Support Blocks 1759-00..

Provides a quick and effective way to support a shaft assembly where there is little or no concern for deflection.



65

# Rexroth Support Rails

## Series 1767-1XX-00 High Profile Support Rails

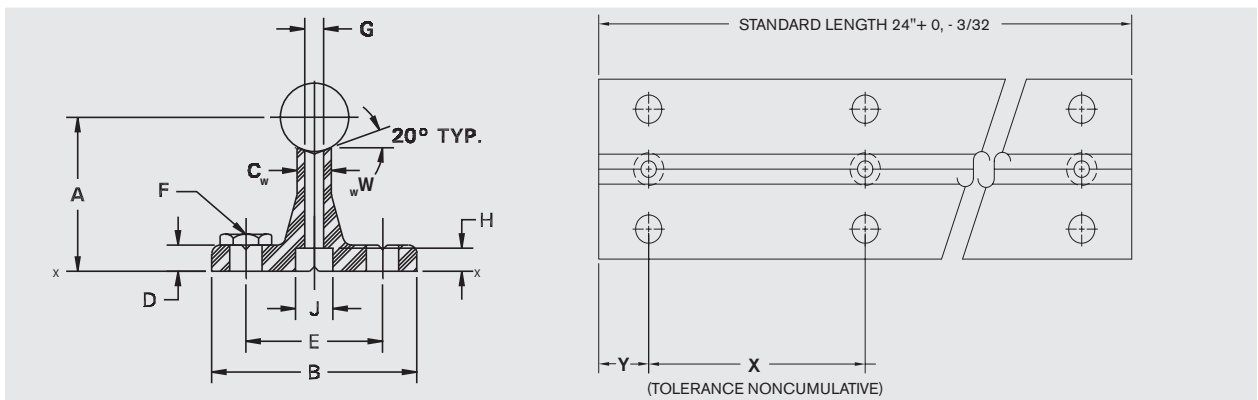
Rexroth Shaft support rails are available in three configurations: Plain, predrilled or special machined.

Support rails are available in shaft diameter sizes 1/2" to 2" as specified in the table below. For shaft sizes not listed, select the closest to that needed. If a shaft falls midway between specified diameters, use the next larger rail.

Standard rails are 24" long. To support longer shafts, several rails may be used in tandem. For shorter shafts, rails may be ordered pre-cut to fit. Also for user convenience, Rexroth support rails have pre-grooved centerlines for easy, accurate drilling of additional holes.

### Specifications

Materials:	6061-T6 aluminum extrusion
Surface finish:	Aluminum mill finish
Length:	24" (tolerance +0, -3/32")
Base hole location:	+/- 0.015" noncumulative



(Figure 25)

### Support Rail Selection Table

Nominal Shaft Diameter (in.)	Part Number <sup>(1)</sup> Predrilled	A +/- 0.002	B	C <sub>w</sub>	D	E	F	G Assembly Bolt	H	X	Y
1/2	1767-108-00	1.125	1.50	0.25	0.19	1.000	#6	6-32x7/8	0.17	4.00	2.00
5/8	1767-110-00	1.125	1.62	0.31	0.25	1.125	#8	8-32x7/8	0.19	4.00	2.00
3/4	1767-112-00	1.500	1.75	0.38	0.25	1.250	#10	10-32x1-1/4	0.22	6.00	3.00
1	1767-116-00	1.750	2.12	0.50	0.25	1.500	1/4	1/4-20x1-1 1/2	0.29	6.00	3.00
1 1/4	1767-120-00	2.125	2.50	0.56	0.31	1.875	5/16	5/16-18x1-3/4	0.34	6.00	3.00
1 1/2	1767-124-00	2.500	3.00	0.69	0.38	2.250	5/16	3/8-16x2	0.41	8.00	4.00
2	1767-132-00	3.250	3.75	0.88	0.50	2.750	3/8	1/2-13x2-1/2	0.53	8.00	4.00

(Table 70)

Note:

(1) Part number for non-drilled rail support is 1767-0XX-00.

# Rexroth Support Rails

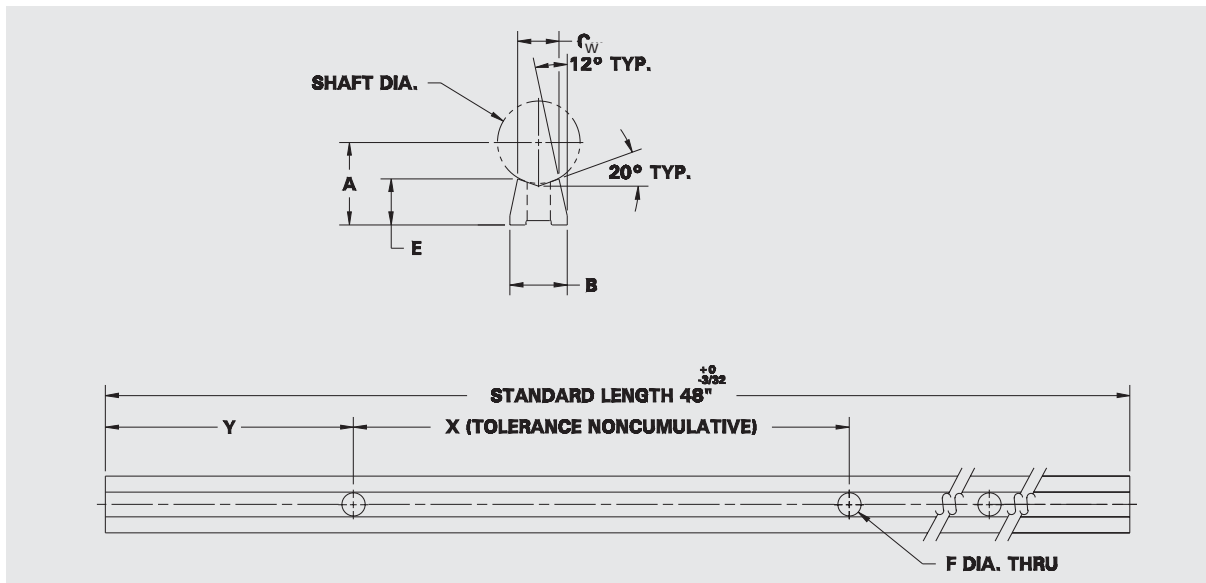
## Series 1768-1XX Low Profile Support Rails

Rexroth Low support rails provide for a very compact and rigid assembly, ideal for designs where the steel shaft can be mounted from below. This ensures a rigid structure by securing the mounting surface, low support rail and shaft together at each mounting point.

Each low support rail is available in standard lengths of 48".

### Specifications

Materials: AISI 1018 Steel  
 Length: 48" (tolerance +0, -3/32")  
 Base hole location: +/- 0.005" noncumulative



(Figure 26)

### Support Rail Selection Table

(Old Series 1767-XXX-37)

Nominal Shaft Diameter (in.)	Part Numbers Predrilled	A +/-0.002	B +/-0.010	C <sub>w</sub> +/-0.010	E Ref.	F Bolt	F Hole	X +/-0.005	Y +/-0.005
1/2	1768-108-00	0.562	0.370	0.250	0.341	6-32	0.169	4.000	2.000
3/4	1768-112-00	0.750	0.510	0.375	0.420	10-32	0.221	6.000	3.000
1	1768-116-00	1.000	0.690	0.500	0.560	1/4-20	0.281	6.000	3.000

(Table 71)

Note:

(1) Part number for non-drilled rail support is 1768-**0**XX-00

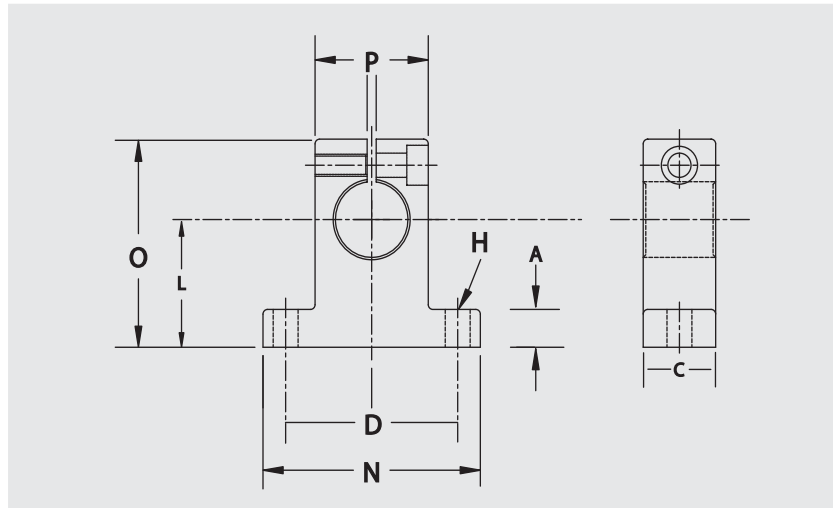
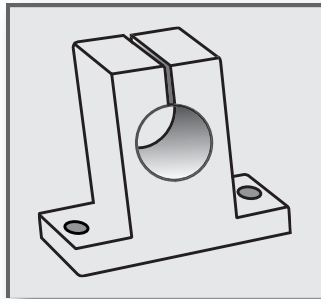


# Rexroth Support Blocks

## Series 1759-XXX Support Blocks

Rexroth Series 1759 - Shaft Support Blocks may be used at end or intermediate positions on stationary shafts. They are ideal where loads are light and deflections between supports pose no problem.

Supports must not interfere with bushing or carriage travel. Shimming is suggested for high precision applications to eliminate the effect of variations in base flatness or support manufacturing tolerances. These blocks provide quick, firm clamping of shafts, reducing the need for specialized mountings and miscellaneous hardware.



(Figure 27)

### Support Block Selection Table

Nominal Shaft Diameter (in.)	Part Number*	L	N	C	O	D	A	P	Weight (lbs)
1/2	1759-008-01	1.00	2.00	0.63	1.63	1.50	0.25	0.88	0.20
3/4	1759-012-01	1.25	2.50	0.75	2.13	2.00	0.31	1.25	0.41
1	1759-016-01	1.50	3.06	1.00	2.56	2.50	0.38	1.50	0.76
1 1/4	1759-020-01	1.75	3.75	1.13	3.00	3.00	0.44	2.00	1.30
1 1/2	1759-024-01	2.00	4.38	1.25	3.50	3.50	0.50	2.25	1.87
2	1759-032-01	2.50	5.50	1.50	4.50	4.50	0.63	3.00	3.74

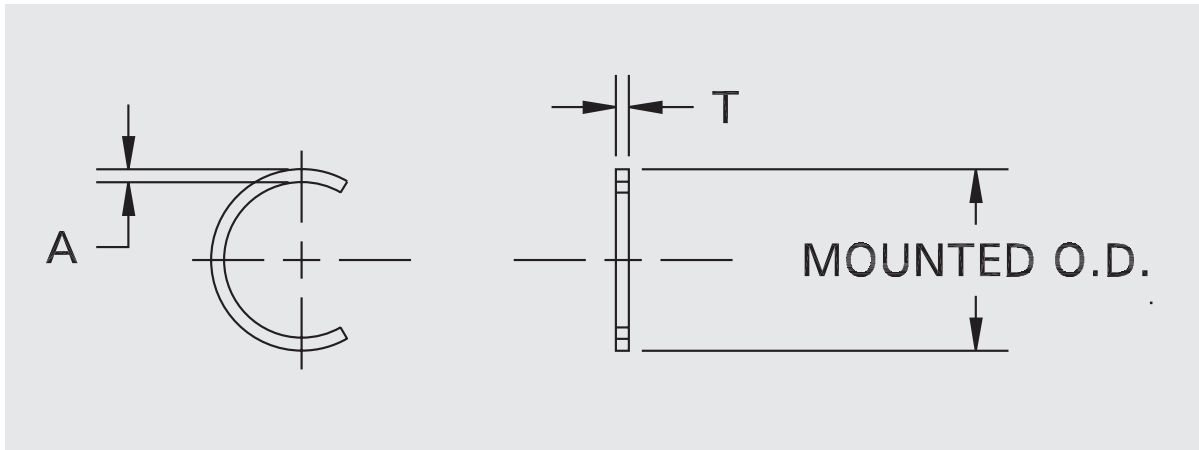
Nominal Shaft Diameter (in.)	Part Number**	H Mounting Hole	
		Bolt	Hole
1/2	1759-008-01	#8	3/16
3/4	1759-012-01	#10	7/32
1	1759-016-01	1/4	9/32
1 1/4	1759-020-01	5/16	11/32
1 1/2	1759-024-01	5/16	11/32
2	1759-032-01	3/8	13/32

(Table 72)

\* Packaged in sets of two.

\*\* 1759-0XX-00 cast iron blocks (Consult factory for dimensional details)

# Rexroth External Retaining Rings



(Figure 28)

## External Ring Selection Table

Part No.	Free I.D.		Mounted O.D. <sub>(1)</sub>	A +/- .001	T +/- .001
	φ	Tol.			
XR-4A	0.469	+0.000	0.539	0.035	0.035
**XRS-4A		- 0.020			
XR-6A	0.588	+0.000	0.658	0.035	0.035
**XRS-6A		- 0.025			
XR-8A	0.821	+0.000	0.905	0.042	0.042
**XRS-8A		- 0.035			
XR-10A	1.059	+0.000	1.159	0.050	0.050
**XRS-10A		- 0.040			
XR-12A	1.176	+0.000	1.276	0.050	0.050
**XRS-12A		- 0.045			
XR-16A	1.468	+0.000	1.592	0.062	0.062
**XRS-16A		- 0.055			
XR-20A	1.886	+0.000	2.036	0.075	0.062
		- 0.065		+/- .002	
XR-24A	2.239	+0.000	2.395	0.078	0.078
		- 0.080			
XR-32A	2.838	+0.000	3.024	0.093	0.093
		- 0.100			
XR-40 <sub>(2)</sub>	3.468	+ .0200	4.310	-----	0.109
		- .0300			+/- .003
XR-48 <sub>(2)</sub>	4.223	+ .0200	5.180	-----	0.109
		- .0300			+/- .003
XR-64 <sub>(2)</sub>	5.631	+ .0200	6.910	-----	0.125
		- .0400			+/- .004

(Table 73)

(1) Reference dimension only

(2) Commercial type with end lugs

\*\*Corrosion resistant material

Note: XR-type made of Spring Steel, XRS-type made of Nickel Plated Spring Steel

# Notes

Bosch Rexroth Corporation  
Linear Motion and  
Assembly Technologies  
14001 South Lakes Drive  
Charlotte, NC 28273  
Telephone (800) 438-5983  
Facsimile (704) 583-0523  
[www.boschrexroth-us.com](http://www.boschrexroth-us.com)

Bosch Rexroth Corporation  
Corporate Headquarters  
5150 Prairie Stone Parkway  
Hoffman Estates, IL 60192-3707  
Telephone (847) 645-3600  
Facsimile (847) 645-6201

Bosch Rexroth Corporation  
Industrial Hydraulics  
2315 City Line Road  
Bethlehem, PA 18017-2131  
Telephone (610) 694-8300  
Facsimile (610) 694-8467

Bosch Rexroth Corporation  
Electric Drives and Controls  
5150 Prairie Stone Parkway  
Hoffman Estates, IL 60192-3707  
Telephone (847) 645-3600  
Facsimile (847) 645-6201

Bosch Rexroth Corporation  
Pneumatics  
1953 Mercer Road  
Lexington, KY 40511-1021  
Telephone (859) 254-8031  
Facsimile (859) 281-3491

Bosch Rexroth Corporation  
Mobile Hydraulics  
1700 Old Mansfield Road  
Wooster, OH 44691-0394  
Telephone (330) 263-3300  
Facsimile (330) 263-3333