

## STAR – Cam Roller Guides

# STAR Linear Motion Technology

## Ball Rail Systems

Standard Ball Rail Systems  
Ball Rail Systems with Aluminum Runner Blocks  
Super Ball Rail Systems  
Wide Ball Rail Systems  
Miniature Ball Rail Systems

## Cam Roller Guides

Accessories

## Roller Rail Systems

## Linear Bushings and Shafts

Linear Bushings  
Linear Sets  
Shafts  
Shaft Support Rails  
Shaft Support Blocks  
Ball Transfer Units

## Screw Drives

Precision Ball Screw Assemblies  
End Bearings and Housings

## Linear Motion Systems

Linear Motion Slides  
Linear Modules  
Compact Modules  
Ball Rail Tables  
Linear Actuators  
ALU-STAR Profile System  
Controllers, Motors, Electrical Accessories

Deutsche Star GmbH  
D-97419 Schweinfurt



REG. No.  
1617 - 03



STAR, Ball Rail and  are trademarks registered for Deutsche Star GmbH, Germany.

Roller Rail is a trademark of Deutsche Star GmbH, Germany.



## STAR – Cam Roller Guides

Product Overview	4
Maximum Permissible Loads	10
Technical Data	14
Life Expectancy and Static Load Safety Factor	17
Mounting Instructions	19
Lubrication	23
Standard Runner Blocks – Dimensions and Part Numbers	24
Guide Rails – Dimensions and Part Numbers	30
Single/Double Bearing Runner Blocks – Dimensions and Part Numbers	36
Guide Rails for Single/Double Bearing Runner Blocks – Dimensions and Part Numbers	40
U-type Cam Roller Guides – Dimensions and Part Numbers	46
Accessories	50
Cam Rollers with Spigots, Assembly Kits	52

# STAR – Cam Roller Guides

## Product Overview

STAR Cam Roller Guides have been specially developed for use in handling and automation applications.

Features:

- high permissible speeds
- compact design
- light weight
- easy mounting
- low friction and extremely low-noise operation
- complete guideway systems
- interchangeability
- elements can be individually ordered and separately stocked

### STAR Profile Runner Block

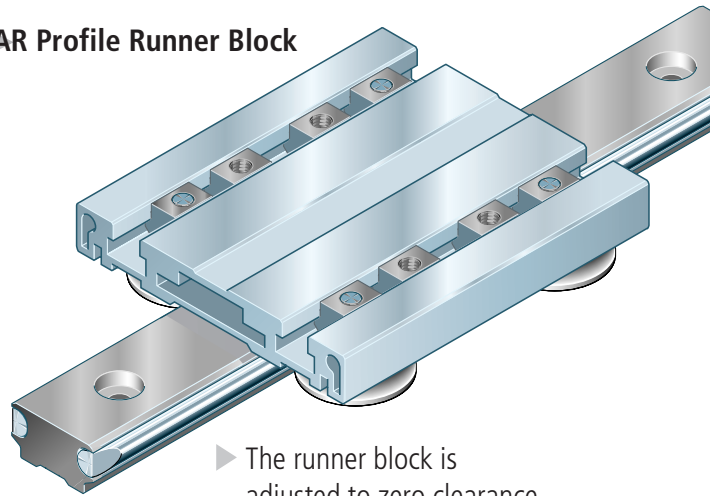

▶ The runner block is adjusted to zero clearance before leaving the factory

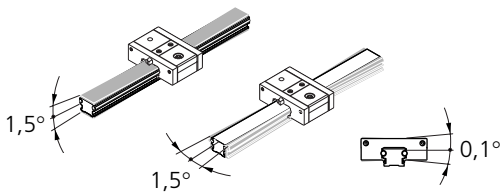

For uneven mounting surfaces or other alignment errors:

### STAR Super Runner Blocks

### STAR Standard Runner Blocks

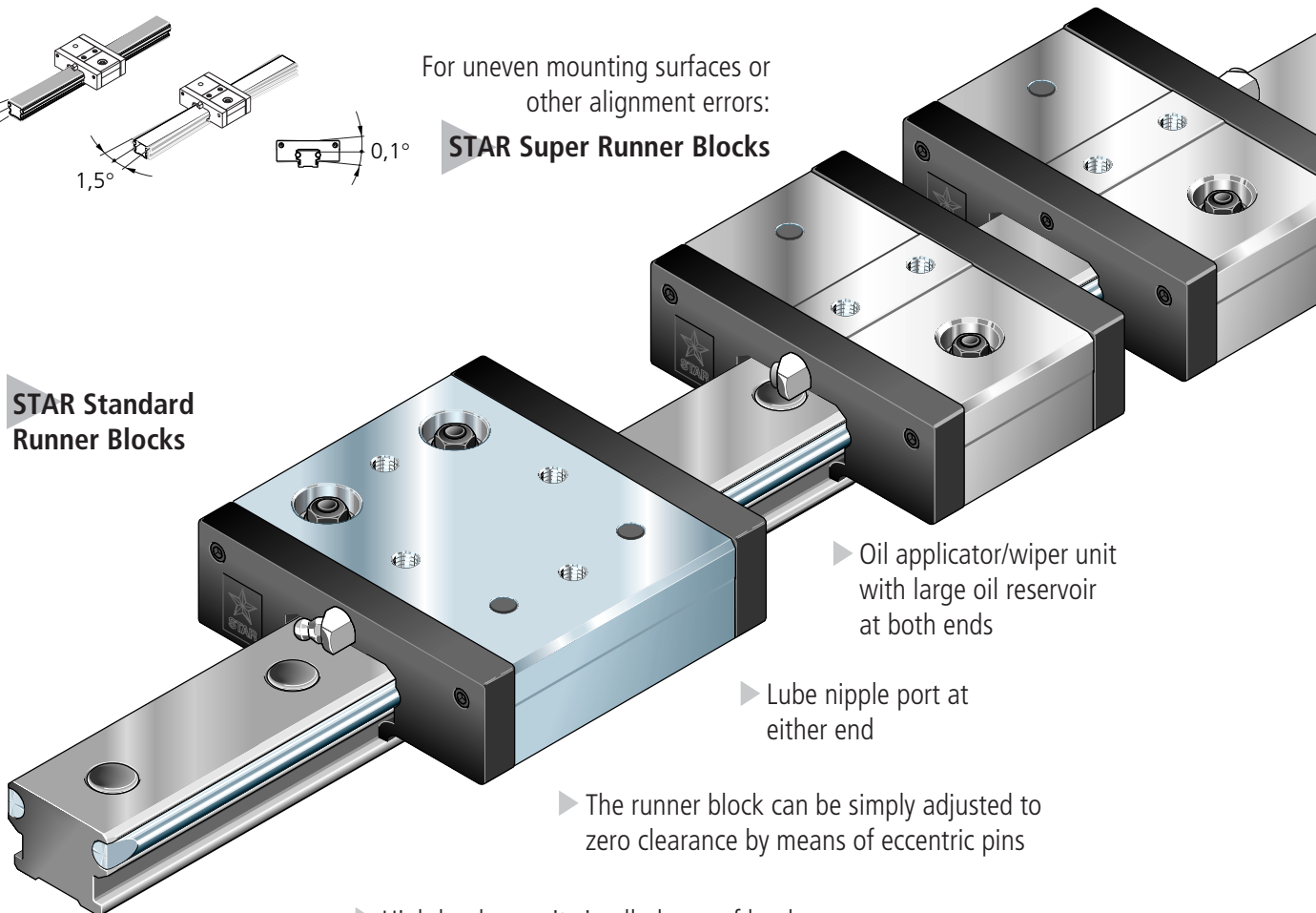

▶ Oil applicator/wiper unit with large oil reservoir at both ends

▶ Lube nipple port at either end

▶ The runner block can be simply adjusted to zero clearance by means of eccentric pins

▶ High load capacity in all planes of load application. High moment capacity about all axes

Standard guide rail

▶ Guide shaft support made of anodized aluminum; optional mounting hole plugs



**STAR Single Bearing Runner Blocks**

Two half-rails

**STAR Double Bearing Runner Blocks**

▶ 2-row angular contact thrust ball bearing, sealed and lubricated for life

▶ Corrosion resistant precision steel shafts as running tracks

**STAR U-type Cam Roller Guides**

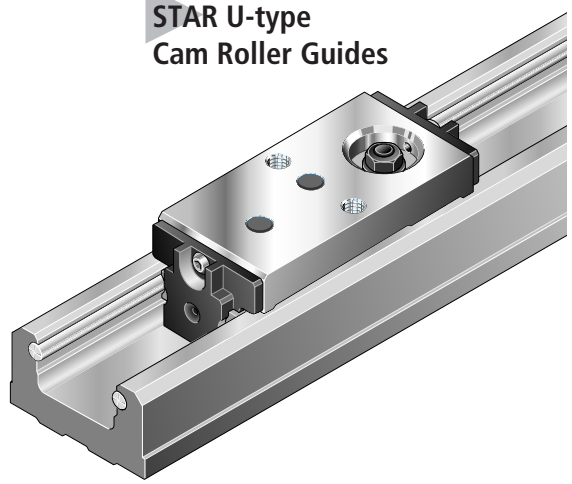

# STAR – Cam Roller Guides

## Product Overview

### Combination options

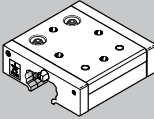
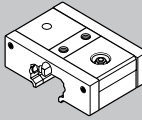
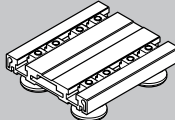
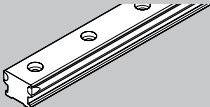
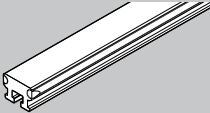
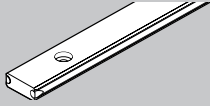
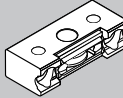
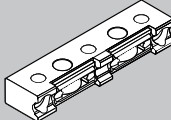
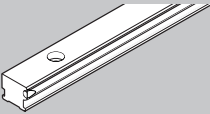
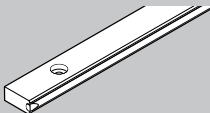
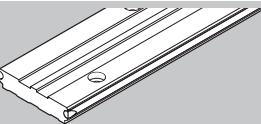
		Page	20	
Standard Runner Block		24	1902-119-00	
Super Runner Block		26	1906-119-00	
Profile Runner Block		28		
Guide Rails	 Standard	30	1921-119-31	
	 With T-Slot	32		
	 Low-profile	34		
Single Bearing Runner Block		36		
Double Bearing Runner Block		38		
Guide Rails for Single/Double Bearing Runner Blocks	 Standard half-rail	40		
	 Low-profile half-rail	42		
	 Wide	44		

Size						
25	32		42	52		
Part number / Size - Version						
1902-125-00	1902-132-00			1902-152-00	1902-252-00 <b>52-h</b> (high loads)	1902-352-00 <b>52-sh</b> (extreme loads)
1906-125-00						
			1907-142-00			
1921-125-31	1921-132-31	1921-232-31 <b>32-2</b> (twice as many mounting holes)	1921-142-31	1921-152-31	1921-252-31 <b>52-2</b> (twice as many mounting holes)	1921-452-31 <b>52-4</b> (four times as many mounting holes)
1922-025-31	1922-032-31			1922-052-31		
	1924-132-31	1924-232-31 <b>32-2</b> (twice as many mounting holes)		1924-152-31	1924-252-31 <b>52-2</b> (twice as many mounting holes)	1924-452-31 <b>52-4</b> (four times as many mounting holes)
	1903-132-10			1903-152-10	1903-252-10 <b>52-h</b> (high loads)	1903-352-10 <b>52-sh</b> (extreme loads)
	1904-132-10			1904-152-10	1904-252-10 <b>52-h</b> (high loads)	1904-352-10 <b>52-sh</b> (extreme loads)
	1925-132-31	1925-232-31 <b>32-2</b> (twice as many mounting holes)		1925-152-31	1925-252-31 <b>52-2</b> (twice as many mounting holes)	1925-452-31 <b>52-4</b> (four times as many mounting holes)
	1926-132-31	1926-232-31 <b>32-2</b> (twice as many mounting holes)		1926-152-31	1926-252-31 <b>52-2</b> (twice as many mounting holes)	1926-452-31 <b>52-4</b> (four times as many mounting holes)
					1927-152-31	

# STAR – Cam Roller Guides

## Product Overview

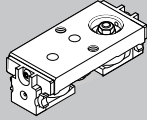
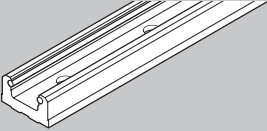
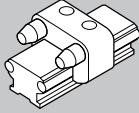
		20	
		Page	
U-type Runner Block		46	1905-119-00
U-type Guide Rail	 U-type	48	1923-119-31
Accessories	 Dead stop	50	



Size			
	25	32	52
Part number / Size - Version			
		1910-532-00	1910-552-00

# STAR – Cam Roller Guides

## Maximum Permissible Loads

**Important:** Not to be used for calculating service life!  
 For service life calculations use the load capacities and moments given in the tables relating to the individual versions.

### Maximum permissible force loads

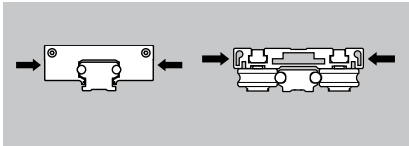
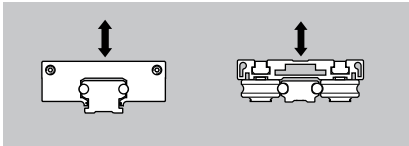
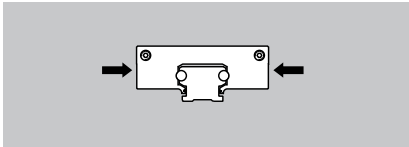
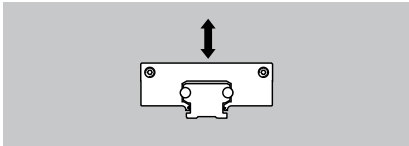
		20	
Standard Runner Block 1902-, 1907-		$F_{\max y}$ (N)*	700
		$F_{\max y0}$ (N)*	700
		$F_{\max z}$ (N)	400
		$F_{\max z0}$ (N)	600
Super Runner Block		$F_{\max y}$ (N)*	350
		$F_{\max y0}$ (N)*	350
		$F_{\max z}$ (N)	200
		$F_{\max z0}$ (N)	300

### Maximum permissible moment loads

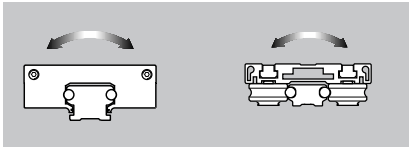
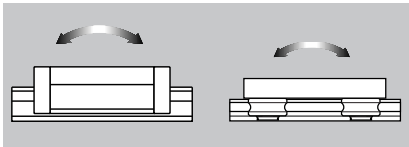
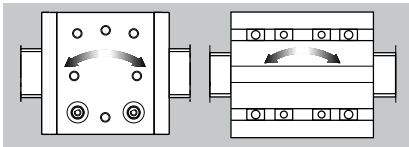
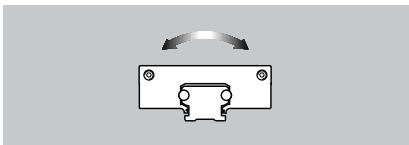
Standard Runner Block 1902-, 1907-		$M_{\max x}$ (Nm)	3.2
		$M_{\max x0}$ (Nm)	4.8
		$M_{\max y}$ (Nm)	6.8
		$M_{\max y0}$ (Nm)	10.2
		$M_{\max z}$ (Nm)	12
		$M_{\max z0}$ (Nm)	12
Super Runner Block		$M_{\max x}$ (Nm)	1.6
		$M_{\max x0}$ (Nm)	2.4

Size - Version								
	25	32	32 32-2	42 	52	52 52-2	52-h 52-2	52-sh 52-4
	700	1000	1400	3000	2500	3500	4500	8000
	700	1000	1400	3000	2500	3500	4500	8000
	400	850	850	1500	1500	1500	2400	4800
	660	1400	1400	2500	2500	2500	4000	7900
	350							
	350							
	200							
	330							

	3.8	11	11	27	32	32	50	101
	6	18	18	42	52	52	84	166
	9	26	26	63	45	45	126	288
	15	42	42	106	75	75	210	474
	16	30	42	127	75	105	236	480
	16	30	42	127	75	105	236	480
	1.9							
	3							

\* Observe permissible side force on the rail (see Mounting Instructions).

# STAR – Cam Roller Guides



## Maximum Permissible Loads

**Important:** Not to be used for calculating service life!  
 For service life calculations use the load capacities and moments given in the tables relating to the individual versions.

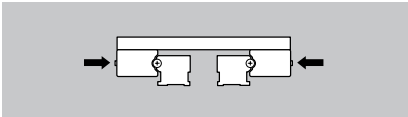
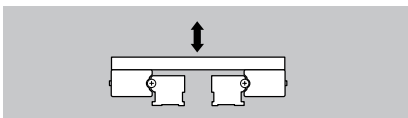
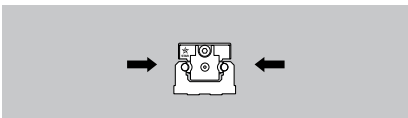
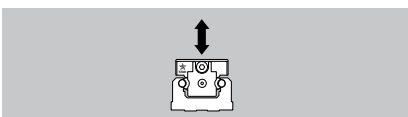
### Maximum permissible force loads

		20	
<b>Four Single/Two Double Bearing Runner Blocks</b>		$F_{\max y}$ (N)	
		$F_{\max z}$ (N)	
<b>U-type Runner Block</b>		$F_{\max y}$ (N)	350
		$F_{\max z}$ (N)	200
		$F_{\max y0}$ (N)	350
		$F_{\max z0}$ (N)	300

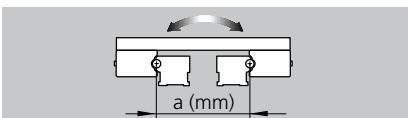
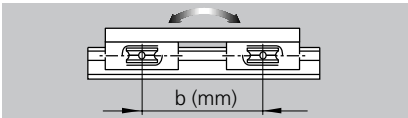
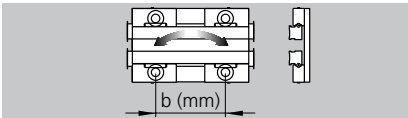
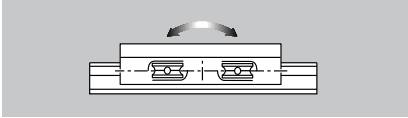
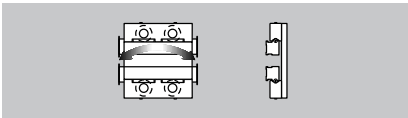
### Maximum permissible moment loads

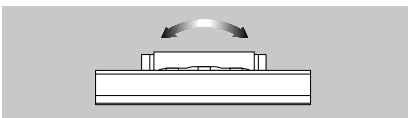
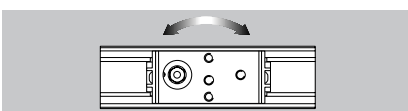
<b>Four Single/Two Double Bearing Runner Blocks</b>		$M_{\max x}$ (Nm)	
		$M_{\max x0}$ (Nm)	
<b>Four Single Bearing Runner Blocks</b>		$M_{\max y}$ (Nm)	
		$M_{\max y0}$ (Nm)	
		$M_{\max z}$ (Nm)	
		$M_{\max z0}$ (Nm)	
<b>Two Double Bearing Runner Blocks</b>		$M_{\max y}$ (Nm)	
		$M_{\max y0}$ (Nm)	
		$M_{\max z}$ (Nm)	
		$M_{\max z0}$ (Nm)	
<b>U-type Runner Block</b>		$M_{\max x}$ (Nm)	1.4
		$M_{\max x0}$ (Nm)	2.2
		$M_{\max y}$ (Nm)	3.4
		$M_{\max y0}$ (Nm)	5.1
		$M_{\max z}$ (Nm)	6.1
		$M_{\max z0}$ (Nm)	6.1

Size - Version							
	25	32	32 32-2	52	52 52-2	52-h 52-2	52-sh 52-4
		1000	1400	2500	3500	4500	8000
		1000	1400	2500	3500	4500	8000
		850	850	1500	1500	2400	4800
		1400	1400	2500	2500	4000	7900
		0.42 · a	0.42 · a	0.75 · a	0.75 · a	1.2 · a	2.4 · a
		0.7 · a	0.7 · a	1.2 · a	1.2 · a	2 · a	3.9 · a
		0.42 · b	0.42 · b	0.75 · b	0.75 · b	1.2 · b	2.4 · b
		0.7 · b	0.7 · b	1.2 · b	1.2 · b	2 · b	3.9 · b
		0.5 · b	0.7 · b	1.2 · b	1.7 · b	2.2 · b	4 · b
		0.5 · b	0.7 · b	1.2 · b	1.7 · b	2.2 · b	4 · b
		21	21	49	49	91	194
		35	35	83	83	152	320
		25	35	83	116	171	324
		25	35	83	116	171	324



# STAR – Cam Roller Guides

## Technical Data

**Maximum travel speed**  
at medium loads

$$v_{\max} = 10 \text{ m/s}$$

**Permissible operating temperature**

$$t = -20 \text{ °C bis } + 80 \text{ °C}$$

### Acceleration

Higher acceleration rates are permissible as long as slip is avoided.

To do this, adjust preload  $F_v$  using the eccentric rollers, see chart.

**⚠** Increasing the preload will reduce the maximum permissible load.

$$a_{\max} = 50 \text{ m/s}^2$$

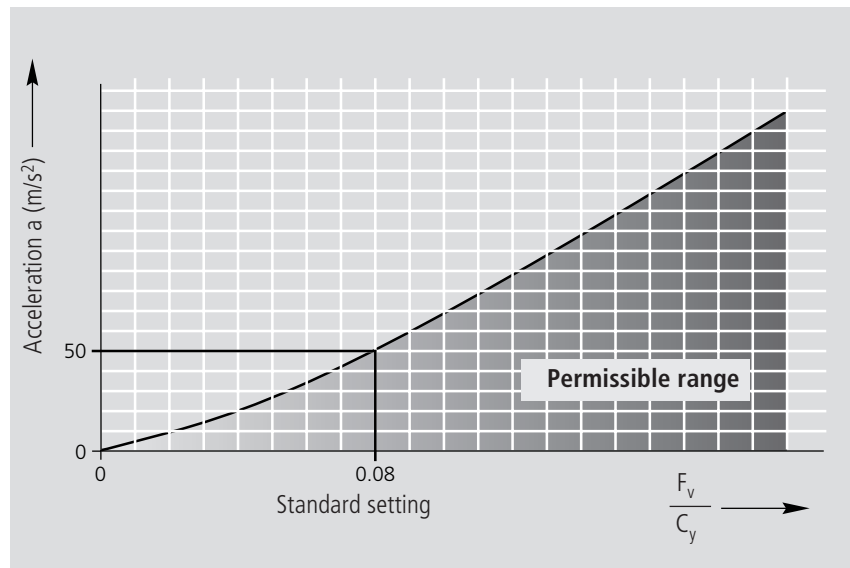

### Rigidity

The rigidity can be improved by increasing the preload using the eccentric rollers.

## Accuracy

STAR Guide Rails are manufactured to very high precision standards.

Higher accuracies are available on request.

Tolerance for H:  
 $\pm 0.2$  mm

Maximum difference in H  
on the same guide rail:  
0.1 mm

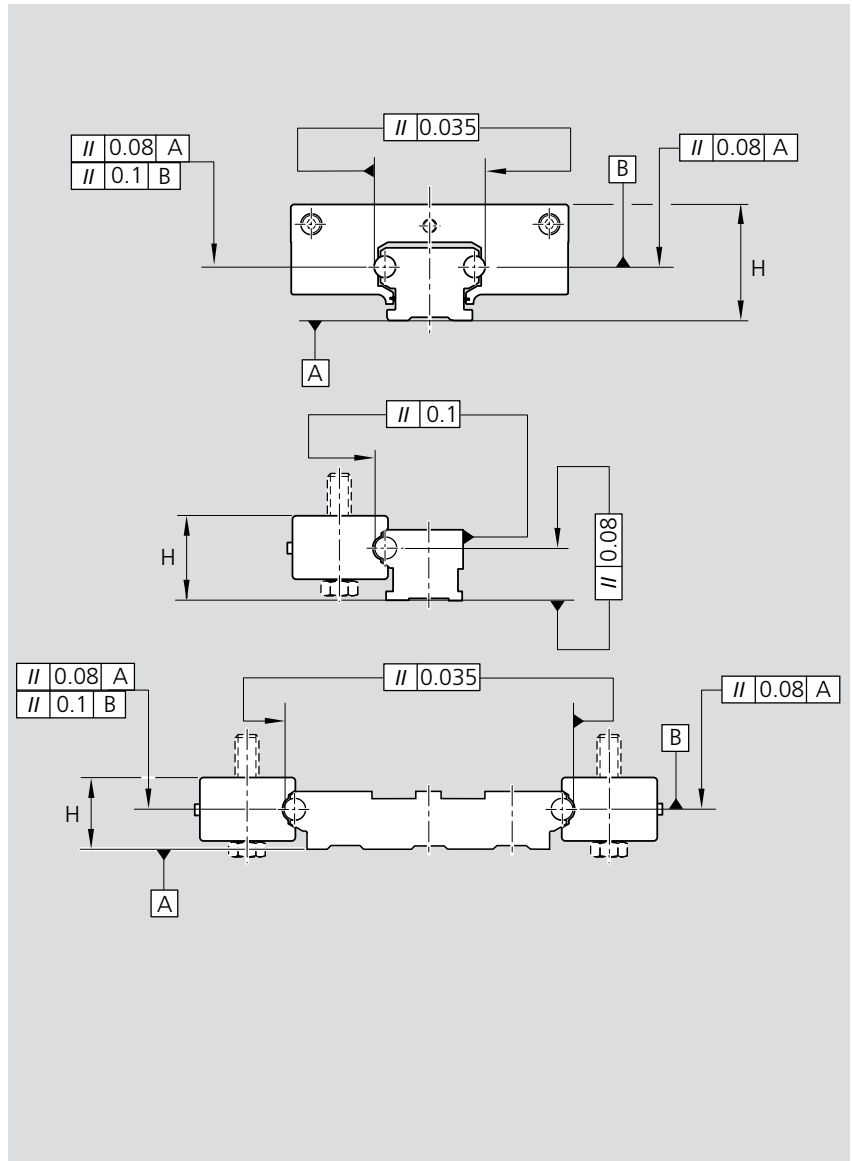

# STAR – Cam Roller Guides

## Technical Data

### Sectional characteristics of guide rails

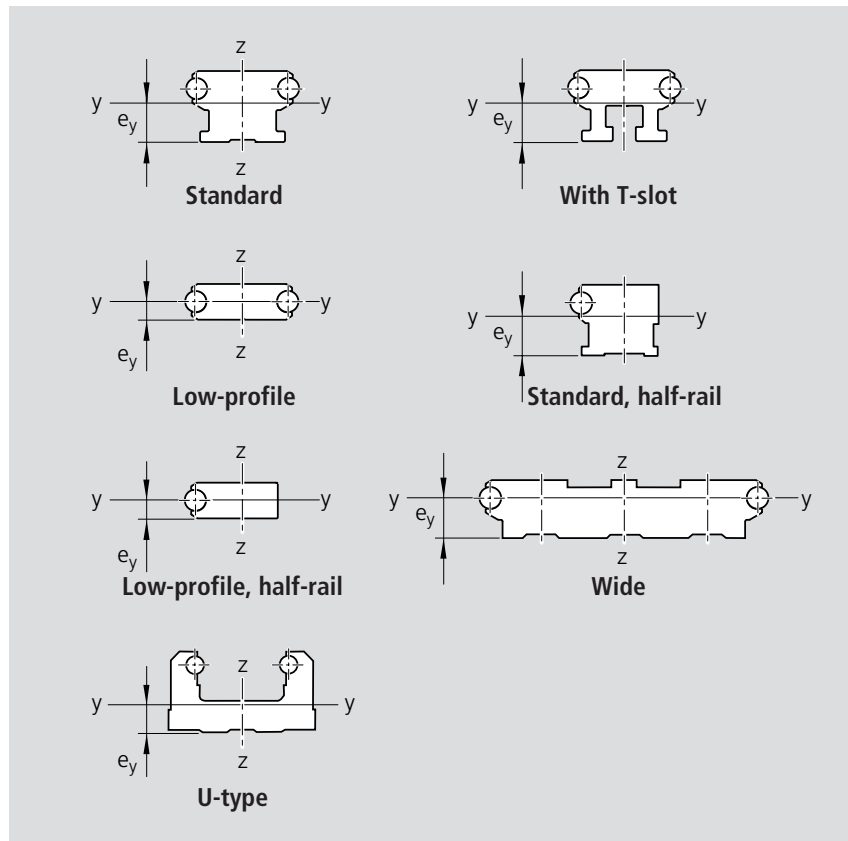

$e_y$ : Centroid distance  
 $I_{y,z}$ : Second moment of inertia  
 $W_{y,z}$ : Section modulus

	Size	Cross-sectional area A (mm <sup>2</sup> )	Neutral axis				
			$e_y$ (mm)	y-y $I_y$ (mm <sup>4</sup> )	$W_y$ (mm <sup>3</sup> )	z-z $I_z$ (mm <sup>4</sup> )	$W_z$ (mm <sup>3</sup> )
Standard	20	168	6.0	2060	343	3090	364
	25	244	7.4	4738	623	6432	613
	32	435	10.4	14551	1399	19272	1357
	42	685	11.4	19628	1722	78534	4363
	52	1222	17.6	117945	6701	148971	6477
With T-slot	25	194	8.1	4155	513	6191	590
	32	355	11.4	12295	1079	18666	1315
	52	913	17.6	82725	4596	140984	6130
Low-profile	32	234	5.0	2163	433	11412	804
	52	690	9.0	20750	2306	91104	3961
Standard, half-rail	32	397	10.5	13182	1255	14724	1115
	52	1116	17.7	105926	5985	111856	5251
Low-profile, half-rail	32	217	5.0	1913	383	8841	665
	52	633	9.0	18142	2016	68209	3202
Wide	52	2492	12.4	119636	2099	2378777	41733
U-type	20	360	7.0	8604	782	42000	2545



# Life Expectancy and Static Load Safety Factor

## Life Expectancy of one Cam Roller

The nominal service life expectancy  $L$  in meters or  $L_h$  in hours is attained or

exceeded by at least 90% of a large number of identical rollers.

### when subject to force loads

If the Cam Roller Guide is subject to a centrally-acting force  $F_y$  or  $F_z$ , calculate the nominal travel life using formulas (1) and (2):

The force  $F$  must not exceed the maximum permissible force given in the "Maximum Permissible Loads" tables.

$(1) \quad L = \left( \frac{C_{y,z}}{F} \right)^3 \cdot 10^5$ $(2) \quad L_h = \frac{L}{2 \cdot s \cdot n \cdot 60}$	$L$ = nominal life expectancy (m) $L_h$ = nominal life expectancy (h) $C_{y,z}$ = dynamic load capacity (N) $F$ = equivalent dynamic load (N) $s$ = length of stroke (m) $n$ = stroke repetition rate (min <sup>-1</sup> ) (complete cycles)
--	---

### when subject to moment loads

If the Cam Roller Guide is subject to a moment  $M$  acting about the x, y or z axis only, calculate the nominal travel life using formulas (3) and (4):

The moment  $M$  must not exceed the maximum permissible moment load given in the "Maximum Permissible Loads" tables.

$(3) \quad L = \left( \frac{M_{x,y,z}}{M} \right)^3 \cdot 10^5$ $(4) \quad L_h = \frac{L}{2 \cdot s \cdot n \cdot 60}$	$L$ = nominal life expectancy (m) $L_h$ = nominal life expectancy (h) $M_{x,y,z}$ = dynamic moment (Nm) $M$ = equivalent dynamic moment load (Nm) $s$ = length of stroke (m) $n$ = stroke repetition rate (min <sup>-1</sup> ) (complete cycles)
--	---

### Note

The above formulas for calculation of life expectancy apply only in applications subject to a single force acting centrally in the y or z axis, or a single moment acting about the x, y or z axis. For applications subject to a combination

of forces from different directions or moments about different axes, or any combination of forces and moments, consult STAR.

### Coordinate system

The following coordinate system is used to define the direction of action of forces and moments:

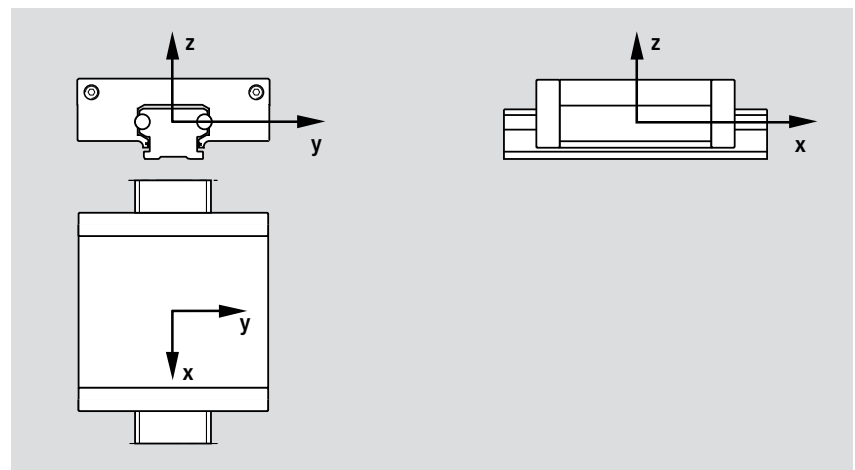

# STAR – Cam Roller Guides

## Life Expectancy and Static Load Safety Factor

### Static Load Safety Factor

#### when subject to force loads

If the Cam Roller Guide is subject to a centrally-acting force  $F_{y0}$  or  $F_{z0}$ , calculate the static load safety factor using formula (5):

The force  $F_0$  must not exceed the maximum permissible force given in the "Maximum Permissible Loads" tables.

$(5) \quad S_0 = \frac{C_{y0, z0}}{F_0}$	$S_0$ = static load safety factor (-) $C_{y0, z0}$ = static load capacity (N) $F_0$ = equivalent static load (N)
--	--

#### when subject to moment loads

If the Cam Roller Guide is subject to a moment  $M_0$  acting about the x, y or z axis only, calculate the static load safety factor using formula (6):

The moment  $M_0$  must not exceed the maximum permissible moment load given in the "Maximum Permissible Loads" tables.

$(6) \quad S_0 = \frac{M_{x0, y0, z0}}{M_0}$	$S_0$ = static load safety factor (-) $M_{x0, y0, z0}$ = static moment (Nm) $M_0$ = equivalent static moment load (Nm)
--	--

#### Note

The above formulas for calculation of the static load safety factor apply only in applications subject to a single force acting centrally in the y or z axis, or a single moment acting about the x, y or z axis.

For applications subject to a combination of forces from different directions or moments about different axes, or any combination of forces and moments, consult STAR.

# Mounting Instructions

## General Instructions

STAR Cam Roller Guides are high-quality products and should be treated with the utmost care during transportation and mounting.

All steel parts are coated with preservative oil. The preservative coating need not be removed provided the recommended lubricants are used in the application.

Unfavorable environmental conditions (vibrations, major temperature fluctuations, etc.) can cause a relative shift between the aluminum frame and the rolled-in (or pressed-in) steel shafts of all guide rails. To prevent this phenomenon we recommend a positive-locking axial retention.

## Guide Rail Mounting

### To mount the guide rail:

- Slightly tighten screws.
- Align guide rail.
- Tighten screws to torque as shown in the table.

Standard Guide Rail (1921-...):  
If the maximum permissible load is to be utilized, install washers to DIN 433.

Guide Rail with T-slot (1922-...):  
Washers are supplied with the rail.

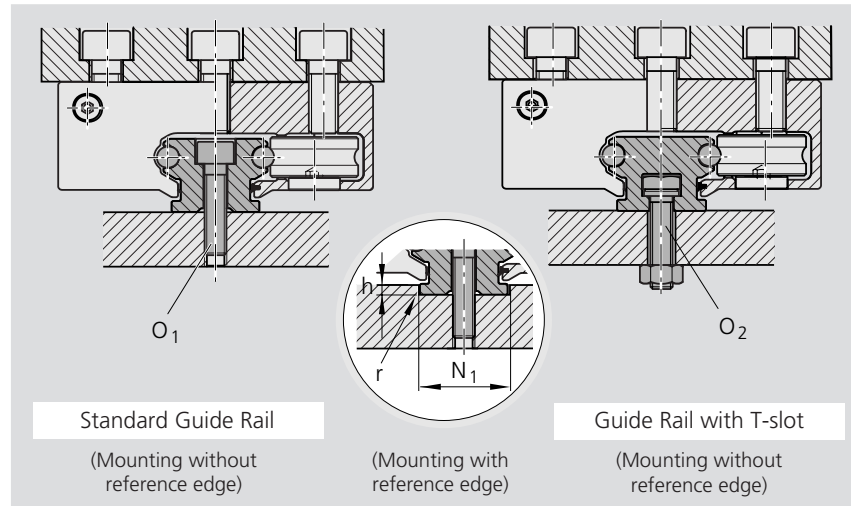

## Screw sizes for guide rails

Standard  
With T-slot

Size - Version	20	25	32	32-2	42	52	52-2	52-4
<b>O<sub>1</sub> (DIN 912)</b>	M4x16	M5x20	M6x25	M6x25	M8x25	M10x40	M10x40	M12x40
<b>O<sub>2</sub> (DIN 931/933)</b>	–	M5	M6	–	–	M10	–	–
<b>N<sub>1</sub> min. (mm)</b>	17.1	21.1	24.1	24.1	–	40.1	40.1	40.1
<b>h max. (mm)</b>	1.0	1.5	3.0	3.0	–	5.0	5.0	5.0
<b>r max. (mm)</b>	0.2	0.2	0.2	0.2	–	0.2	0.2	0.2

## Permissible side loads

Recommended values for permissible side forces without additional lateral retention of the rail.

Size - Version	20	25	32	32-2	42	52	52-2	52-4
<b>F<sub>per</sub> (N)</b>	200	330	450	900	1000	1000	1600	4000

## Composite Guide Rails made up of several sections

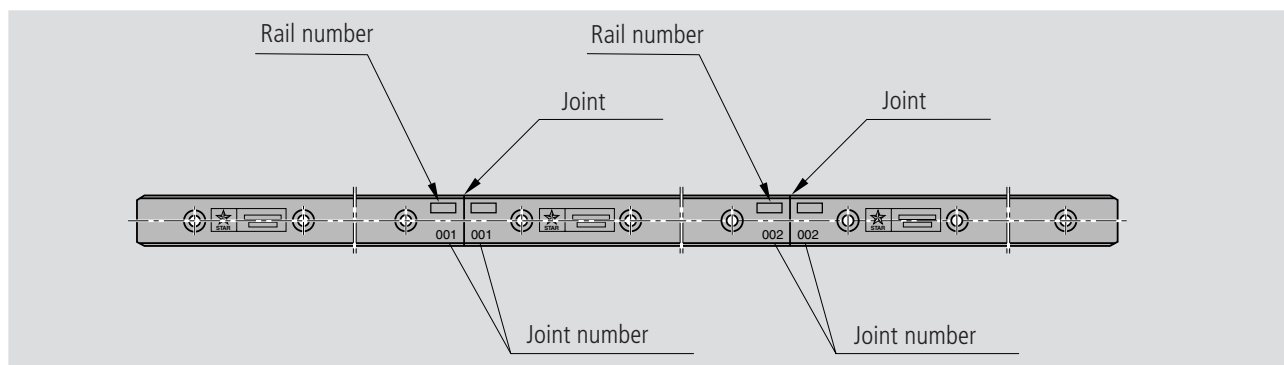

# STAR – Cam Roller Guides Mounting Instructions

## Instructions for mounting Standard and Super Runner Blocks to the Guide Rail

To mount the runner block:

The oil applicator and wiper units ("oiling units" for short) are delivered separate to facilitate installation work.

- Push on the first oiling unit (1):  
The felt wiper strips are automatically pressed in by the chamfers on the steel shafts.
- Carefully slide the runner block (2) onto the guide rail.

- Adjust the eccentric rollers (4a), until a slight shifting force  $F_R$  is felt (see table for recommended values).
- Tighten the hex nut to torque as shown in the table using a hex wrench to stop the pin from turning (4b).
- Mount the second oiling unit (3).
- Screw the two oiling units to the runner block (5).

**⚠** After mounting, the runner block should move freely when pushed.

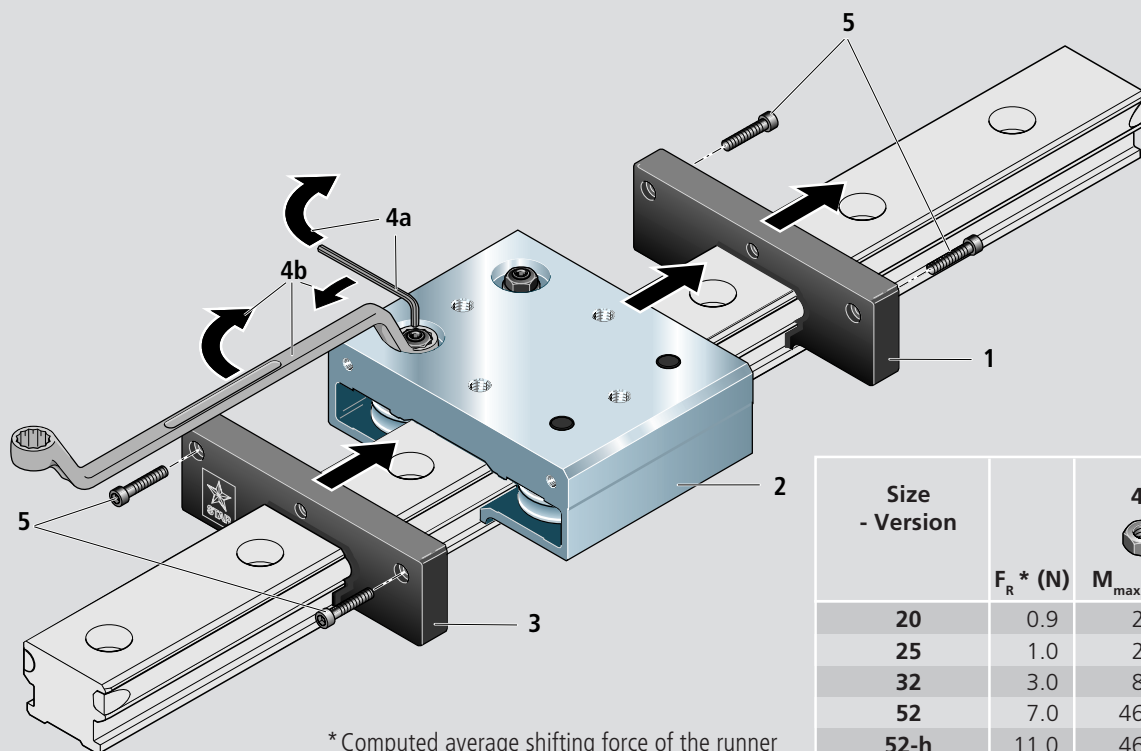
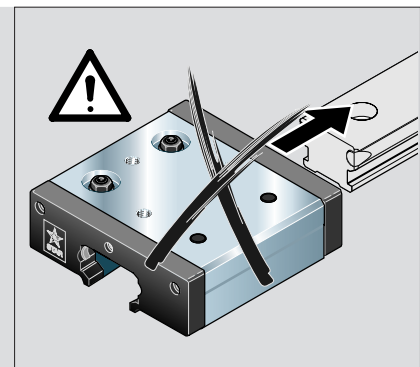
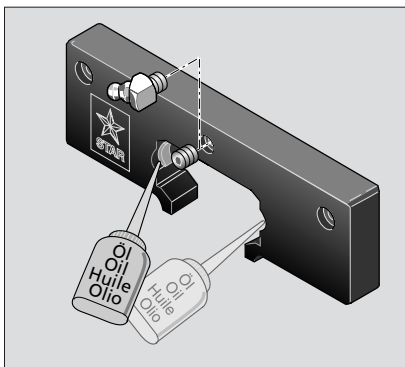

\* Computed average shifting force of the runner block for standard adjustment 0.08 C

Size - Version	4b	
	$F_R$ * (N)	$M_{max}$ (Nm)
20	0.9	2.0
25	1.0	2.7
32	3.0	8.0
52	7.0	46.0
52-h	11.0	46.0
52-sh	13.0	80.0

## Mounting Superstructures on Runner Blocks:

### Standard Runner Block 1902-, 1906-

- Use screws as per table. Do not use overlong screws! Observe the minimum material strength N!
- Align the superstructure.
- Torque up the screws to the values given in the table.

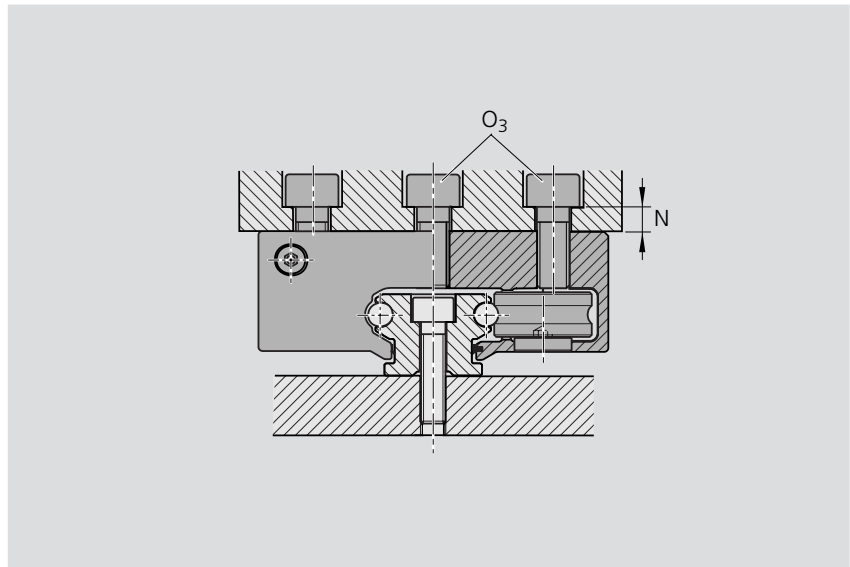

### Profile Runner Block 1907-

- Use screws as per table. Do not use overlong screws! Observe the minimum material strength N!
- Align the superstructure.
- Torque up the screws to the values given in the table.

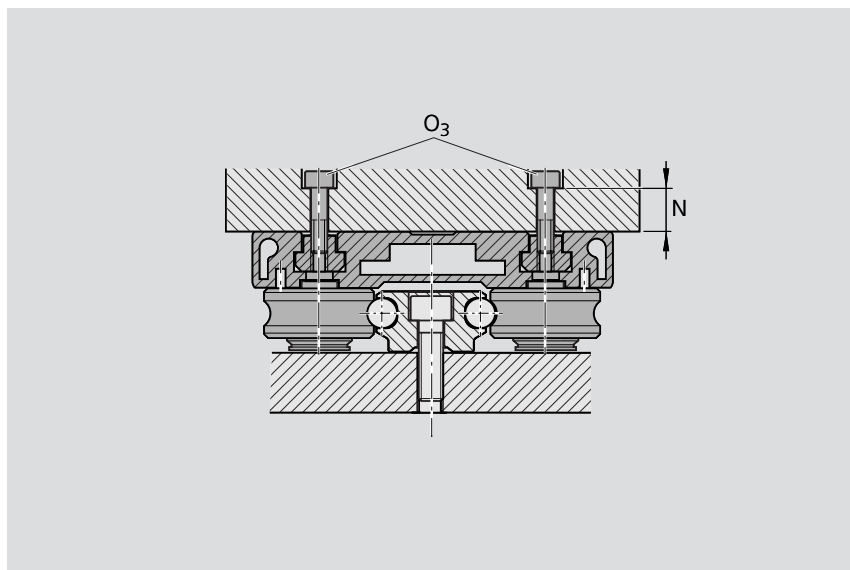

### Runner Blocks

Size - Version	20	25	32	42	52	52-h	52-sh
<b>O<sub>3</sub></b> (DIN 912)	M5x16	M5x16	M8x25	M8x20	M10x30	M10x35	M12x35
<b>N</b> (mm)	8	7	7	7	12	12	12

### Tightening torques for mounting screws

	8.8	M4	M5	M6	M8	M10	M12
 (Nm)		2.7	5.5	9.5	23	46	80

### Design of mounting surface

Unevenness or distortion of mounting surfaces (adjoining structures) will impair the accuracy of the guideway and should be kept to a minimum.

# STAR – Cam Roller Guides Mounting Instructions

## Mounting Single/Double Bearing Runner Blocks with Adjustment Screws

### 1. Mounting

- Align and mount the rails.
- Preassemble runner blocks (1+2) on the carriage (3). Do not yet tighten the screws.
- Align the runner blocks on one side (1) of the carriage (3) and tighten the mounting screws (4) alternately until tightening torque  $M_A$  is reached.
- Slide the carriage (3) onto the rails (5).
- Adjust the runner blocks on the opposite side (2) to zero clearance against the guide rail using adjustment screws (6). Adjust the preload.
- Alternately tighten the mounting screws (7) on the runner blocks (2) until tightening torque  $M_A$  is reached.

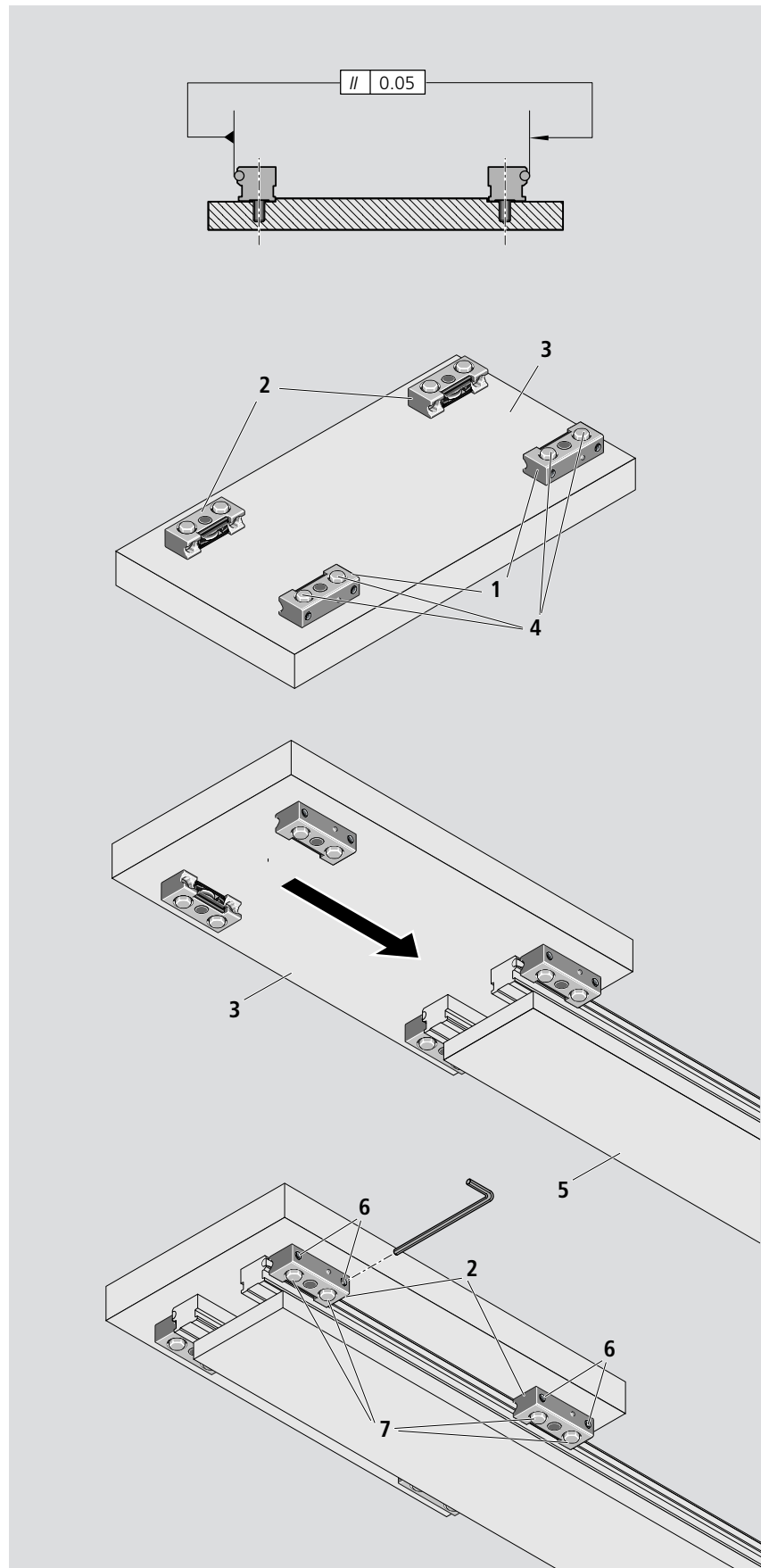

Size	32	52	52-h	52-sh
- Version				
$M_A$ (Nm)	23	46	80	80

# Lubrication

## Lubrication

The runner blocks have an oiling unit at each end.

Apply oil to the felt wiper strips before installing runner blocks.

The oiling unit incorporates a large oil reservoir. To ensure long lubrication intervals, completely fill the reservoir until excess oil emerges.

### Oiling unit with large oil reservoir 1910-4..-00 (see table for volumes)

- Longer travel until in-service lubrication required: 15 · 10<sup>5</sup> m stroke.
- Dual function: simultaneous lubricating and wiping.
- Targeted shaft lubrication.
- Lubrication even at 90° orientation.

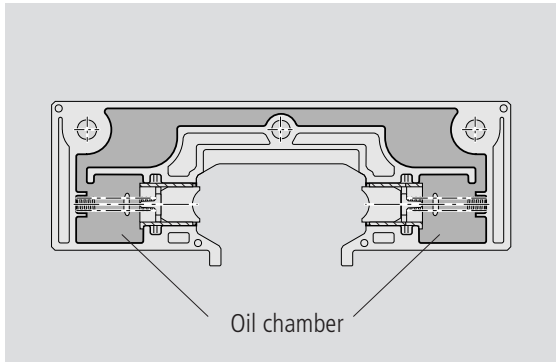

Size - Version	Oil volume (cm <sup>3</sup> )
20	2.5
25	3.0
32	6.5
52	18.0
52-h	20.0
52-sh	20.0

### Lubricant:

#### Oil lubrication of runner blocks (including U-type)

We recommend the use of oil with a viscosity of about 680 mm<sup>2</sup>/s at 40 °C.

#### Grease lubrication of single/double bearing runner blocks

We recommend grease lubricants to DIN 51825 - K2K .

Caution: Do not use greases containing solid lubricant particles (e.g., graphite or MoS<sub>2</sub>).

In-service lubricating intervals will depend on the application and the ambient conditions.

- Lubricate S/D bearing runner blocks until excess grease emerges.

- For double bearing runner blocks, use both lube nipples (8)!

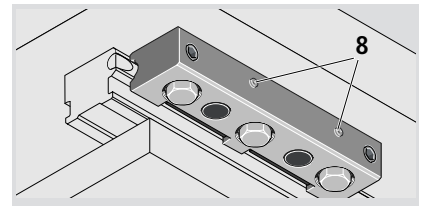

### Minimum stroke length

As a rule, the stroke length should not be less than the length of the runner block. For applications with shorter stroke lengths, consult STAR.

### Angular contact bearings

The angular contact ball bearings in the roller elements are sealed and lubricated for life.

# STAR – Cam Roller Guides Standard Runner Blocks

## Runner Block 1902-

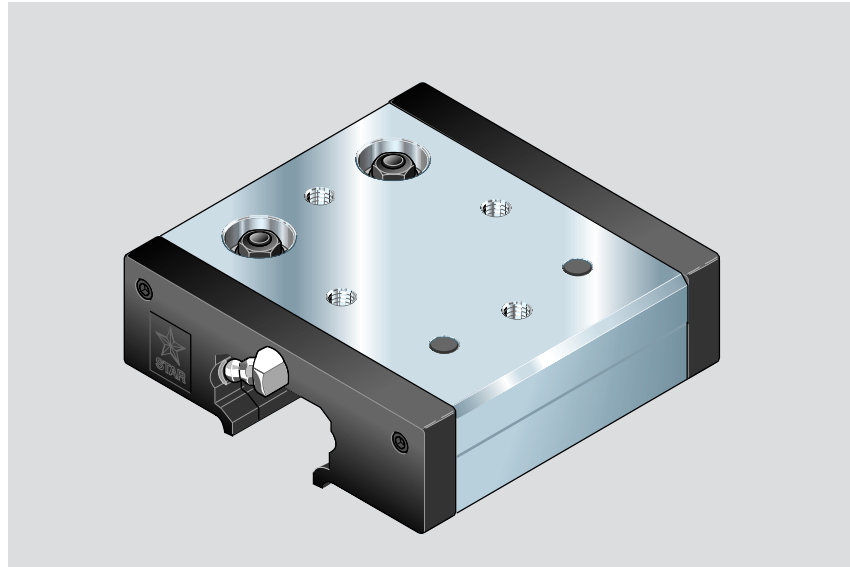

Part numbers,  
load capacities and moments for calculating service life

Size - Version	Part number	Load capacities and moments									
		$C_y$ (N)	$C_{y0}$ (N)	$C_z$ (N)	$C_{z0}$ (N)	$M_x$ (Nm)	$M_{x0}$ (Nm)	$M_y$ (Nm)	$M_{y0}$ (Nm)	$M_z$ (Nm)	$M_{z0}$ (Nm)
20	1902-119-00	2300	1600	1336	783	10.7	6.3	22.7	13.3	39	27
25	1902-125-00	2550	1780	1357	803	13.0	7.6	30.5	18.0	57	40
32	1902-132-00	7335	4560	4300	2200	56.0	29.0	129.0	66.0	220	137
52	1902-152-00	17150	10200	10050	4900	211.0	103.0	301.0	147.0	515	306
52-h	1902-252-00	27900	15400	16775	7630	352.0	160.0	880.0	400.0	1465	808
52-sh	1902-352-00	31000	18200	18400	8750	390.0	184.0	1100.0	520.0	1860	1100

### Important:

Observe maximum permissible loads due to forces and moments as shown in the "Maximum Permissible Loads" tables!

The part numbers refer to runner blocks with oiling units.

Part numbers for runner blocks without oiling units:

1901- ...-00 (otherwise as shown in table)

Part numbers for oiling units without runner blocks:

1910- 4..-00 (otherwise as shown in table)



Adjustment of eccentric pin

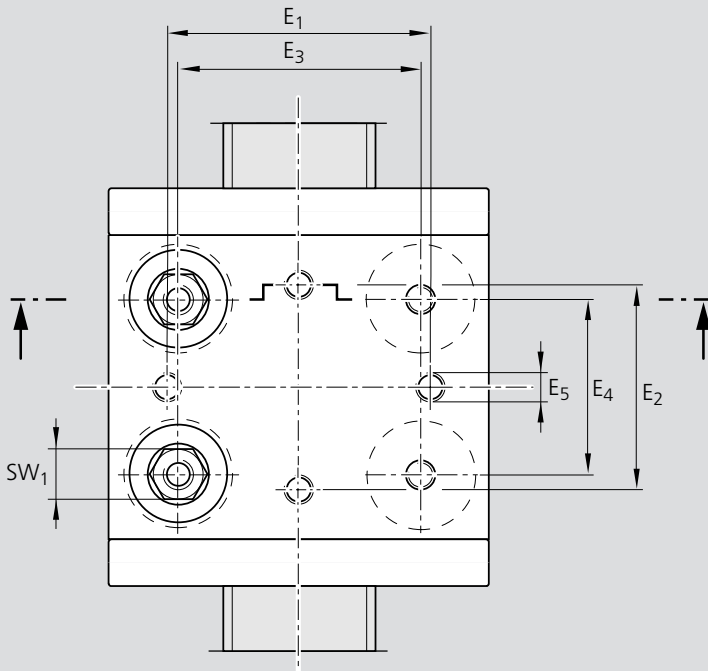
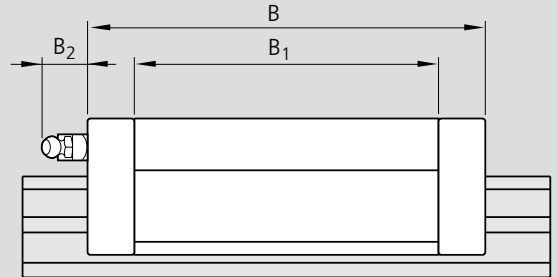
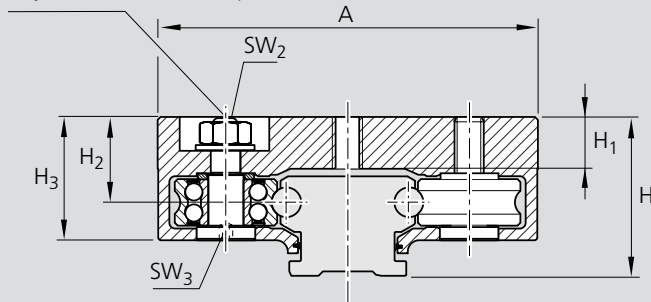

### Lube nipples

#### Size 20 – 32:

Funnel-type nipple  
Type B - Thread size M3

#### Size 52 – 52-sh:

Tapered lube nipple  
BM 6 DIN 71412

Lube nipple port at either end.

Center pins are already tightened on delivery

Size - Version	Dimensions (mm)															Mass (kg)	
	A	B	B <sub>1</sub>	B <sub>2</sub>	H	H <sub>1</sub>	H <sub>2</sub>	H <sub>3</sub>	E <sub>1</sub>	E <sub>2</sub>	E <sub>3</sub>	E <sub>4</sub>	E <sub>5</sub>	SW <sub>1</sub>	SW <sub>2</sub>		SW <sub>3</sub>
20	56	79	59	7	22.0	8.5	13.0	20.0	39	49	34.0	34	M5	7	2	2	0.20
25	65	95	75	7	25.0	9.0	14.4	22.3	50	60	40.0	45	M5	7	2	2	0.25
32	86	112	92	7	35.5	13.0	20.5	29.5	59	70	54.0	60	M8	10	3	4	0.56
52	130	136	104	16	54.3	19.4	29.2	42.2	90	70	83.3	60	M10	16	4	6	1.50
52-h	145	186	154	16	60.4	24.0	35.3	51.0	105	110	90.0	105	M10	16	4	6	2.60
52-sh	155	205	173	16	60.4	24.0	35.3	51.0	115	140	95.0	120	M12	18	6	8	3.30

# STAR – Cam Roller Guides Super Runner Blocks

## Runner Block 1906-

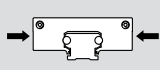
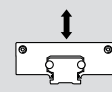
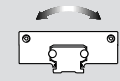

Part numbers,  
load capacities and moments for calculating service life

Size - Version	Part number	Load capacities and moments					
		 $C_y$ (N)   $C_{y0}$ (N)		 $C_z$ (N)   $C_{z0}$ (N)		 $M_x$ (Nm)   $M_{x0}$ (Nm)	
20	1906-119-00	1150	800	660	390	5.4	3.1
25	1906-125-00	1275	890	670	400	6.5	3.8

### Important:

Observe maximum permissible loads due to forces and moments as shown in the "Maximum Permissible Loads" tables!

The part numbers refer to runner blocks with oiling units.

Part numbers for runner blocks without oiling units:  
1906- 1..-30 (otherwise as shown in table)

Part numbers for oiling units without runner blocks:  
1910- 4..-00 (otherwise as shown in table)

Adjustment of eccentric pin

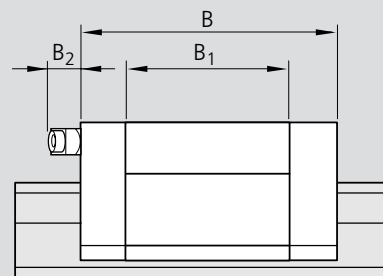
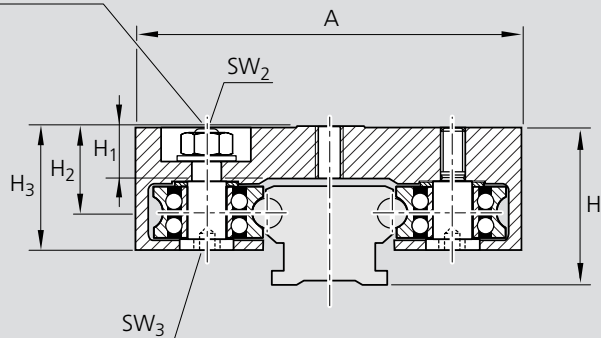

### Lube nipples

Funnel-type nipple  
Type B - Thread size M3

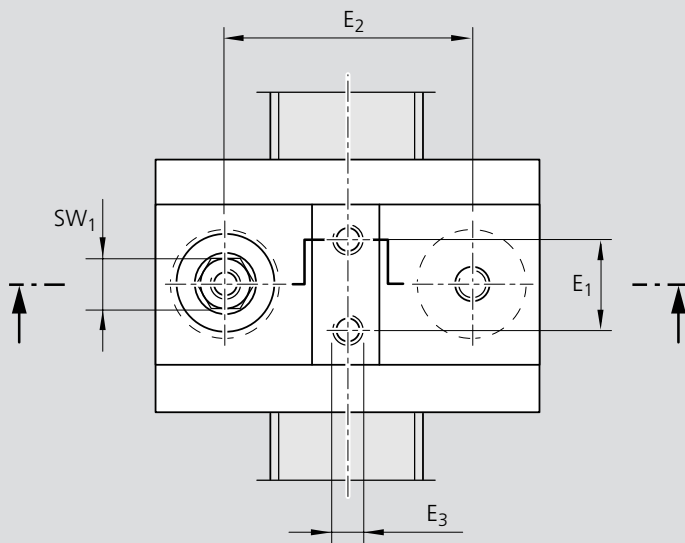

Center pins are already tightened on delivery

Size - Version	Dimensions (mm)														Mass (kg)
	A	B	B <sub>1</sub>	B <sub>2</sub>	H	H <sub>1</sub>	H <sub>2</sub>	H <sub>3</sub>	E <sub>1</sub>	E <sub>2</sub>	E <sub>3</sub>	SW <sub>1</sub>	SW <sub>2</sub>	SW <sub>3</sub>	
20	56	50	30	7	22.0	8.5	13.0	20.0	17	34	M5	7	2	2	0.10
25	65	50	30	7	25.0	9.0	14.4	22.3	20	40	M5	7	2	2	0.10

# STAR – Cam Roller Guides Runner Blocks

## Profile Runner Block 1907-

Lubrication unit in preparation.

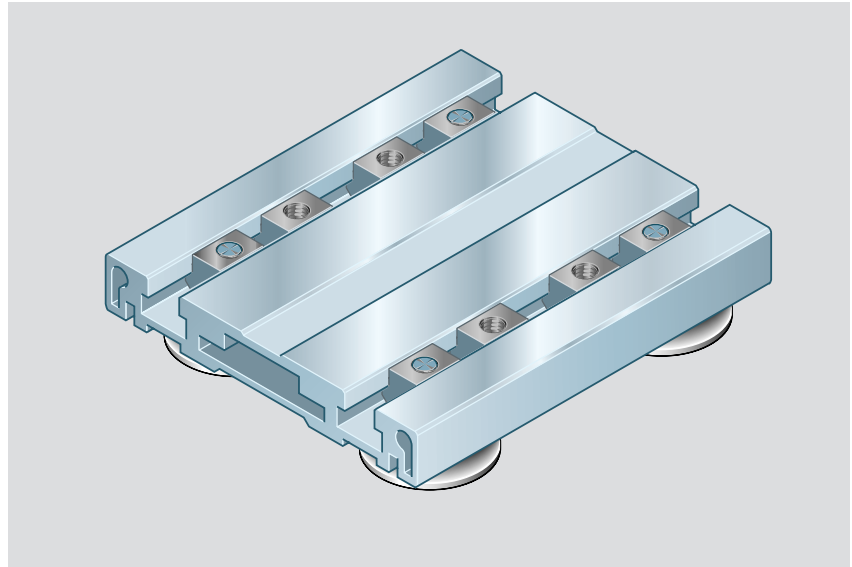

Part numbers,  
load capacities and moments for calculating service life

Size - Version	Part number	Load capacities and moments									
		$C_y$ (N)	$C_{y0}$ (N)	$C_z$ (N)	$C_{z0}$ (N)	$M_x$ (Nm)	$M_{x0}$ (Nm)	$M_y$ (Nm)	$M_{y0}$ (Nm)	$M_z$ (Nm)	$M_{z0}$ (Nm)
42	1907-142-00	17150	10200	10050	4900	162	97	430	258	729	433

### Important:

Observe maximum permissible loads due to forces and moments as shown in the "Maximum Permissible Loads" tables!

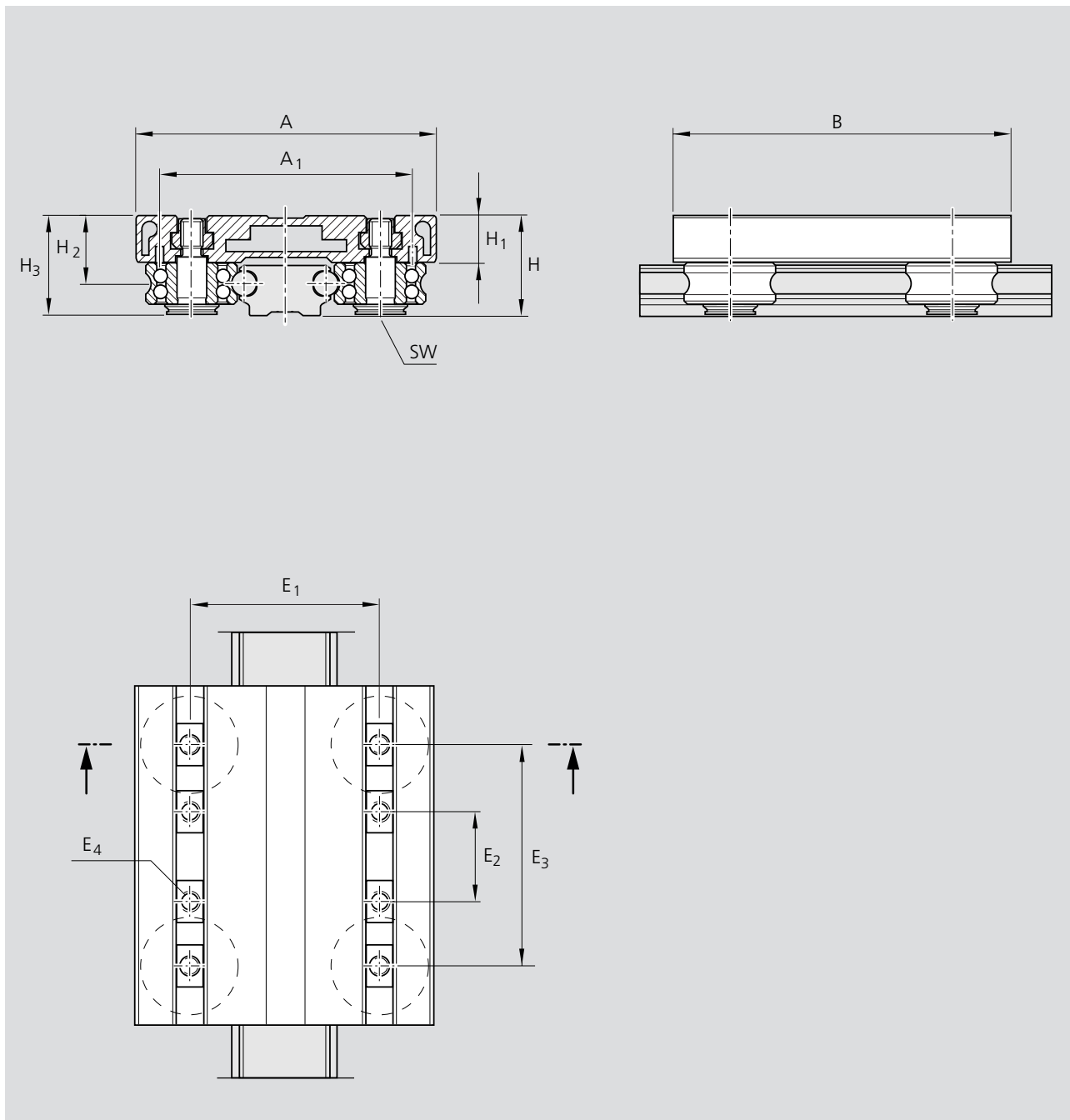

Size - Version	Dimensions (mm)												Mass
	A	A <sub>1</sub>	B	H	H <sub>1</sub>	H <sub>2</sub>	H <sub>3</sub>	E <sub>1</sub>	E <sub>2</sub>	E <sub>3</sub>	E <sub>4</sub>	SW	(kg)
42	116	98.5	150	39	18	26.4	38.1	73	15 - 55	85	M8	6	1.03

# STAR – Cam Roller Guides

## Guide Rails

### Guide Rail standard 1921-

- For mounting from above
- Optional mounting hole plugs (to be ordered separately)
- Corrosion resistant steel shafts to DIN 17230 / EN 10088

**⚠** Standard Guide Rails are not suitable for use with the ALU-STAR Profile System. For guide rails with hole spacing  $T = 60$  mm for the ALU-STAR Profile System, see the ALU-STAR Profile System catalog 82 852.

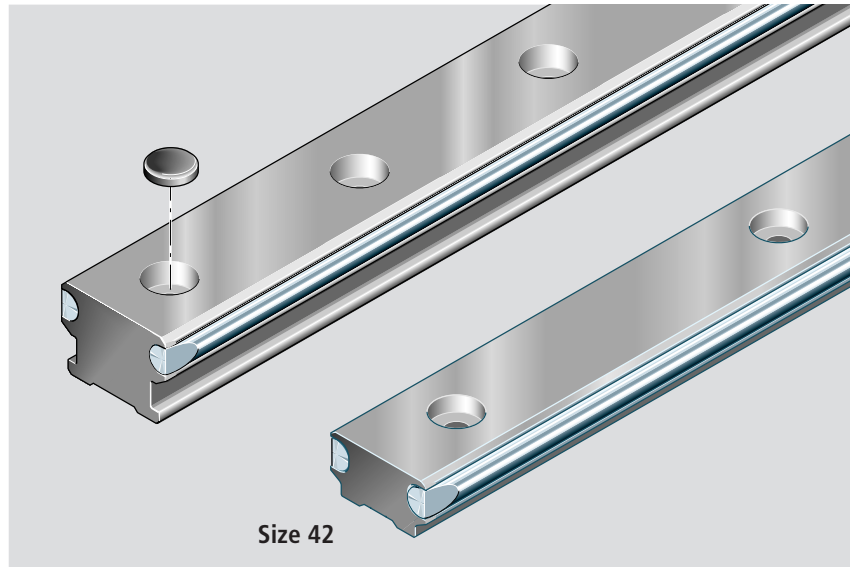

### Part numbers, lengths

Size - Version	Standard length <sup>1)</sup> (mm)	L <sub>max</sub> (mm)	without holes	with holes	Mounting hole plugs	
			Part number Length:,...(mm)	Part number Length:,...(mm)	Part number Quantity:,...	Holes per meter <sup>2)</sup>
20	3500	7000	1921-019-31,...	1921-119-31,...	1605-800-90,...	16
25	3500	7000	1921-025-31,...	1921-125-31,...	1605-800-90,...	16
32	3500	7000	1921-032-31,...	1921-132-31,...	1605-200-90,...	8
32-2	3500	7000	–	1921-232-31,...	1605-200-90,...	16
42	3500	7000	1921-042-31,...	1921-142-31,...	1605-300-90,...	8
52	3500	7000	1921-052-31,...	1921-152-31,...	1605-400-90,...	4
52-2	3500	7000	–	1921-252-31,...	1605-400-90,...	8
52-4	3500	7000	–	1921-452-31,...	1605-500-90,...	16

<sup>1)</sup> Running tracks up to 3500 mm are made of one-piece precision steel shafts.

<sup>2)</sup> Number for one meter at preferred length  $T_{15}$

Size - Version	Hole spacing T (mm)	Recommended rail lengths			
		Number of holes/Rail length L (mm)			
20, 25, 32-2, 52-4	62.5	2/121	10/621	18/1121	40/2496
		4/246	12/746	20/1246	50/3125
		6/371	14/871	24/1496	56/3496
		8/496	16/996	30/1871	
32, 42, 52-2	125	2/246	10/1246	18/2246	28/3496
		4/496	12/1496	20/2496	
		6/746	14/1746	22/2746	
		8/996	16/1996	24/2996	
52	250	2/496	6/1496	14/3496	
		3/746	8/1996		
		4/996	10/2496		
		5/1246	12/2996		

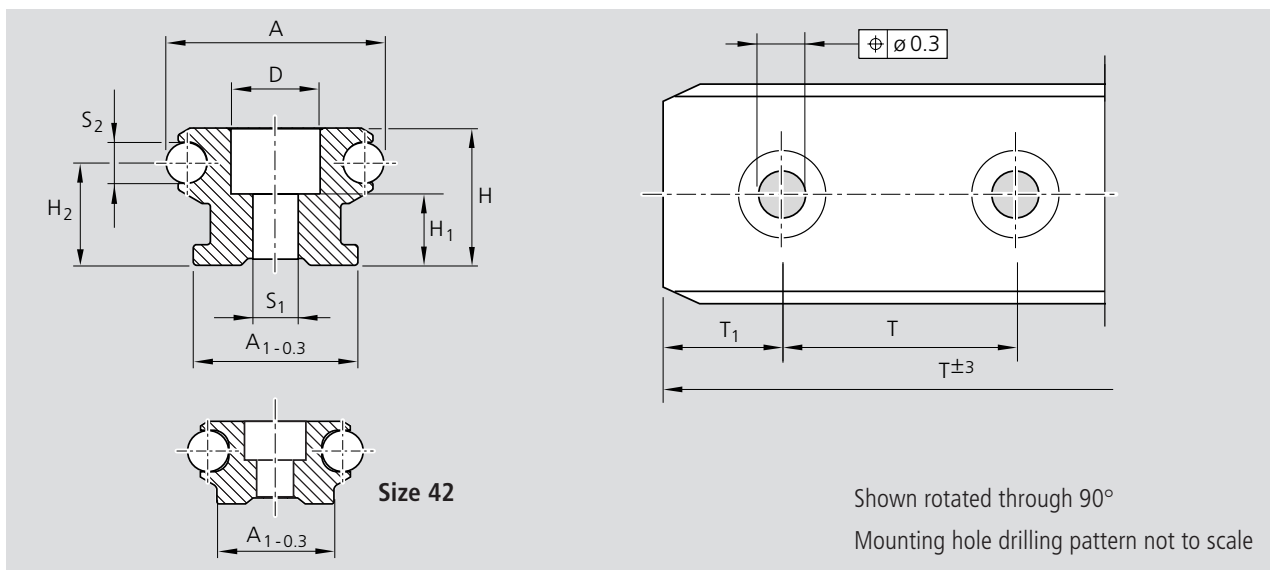

Size - Version	Dimensions (mm)											Mass kg/m
	A	A <sub>1</sub>	H	H <sub>1</sub>	H <sub>2</sub>	D	S <sub>1</sub>	S <sub>2</sub>	T	T <sub>1s</sub>	T <sub>1 min.</sub>	
20	20	17	12	5.0	9.0	9.4	4.5	4	62.5	29.25	13	0.60
25	25	21	15	6.0	10.6	9.4	5.5	6	62.5	29.25	13	1.00
32	32	24	20	9.5	15.0	11.0	6.5	6	125.0	60.50	13	1.60
32-2	32	24	20	9.5	15.0	11.0	6.5	6	62.5	29.25	13	1.60
42	42	28	20	9.0	12.6	15.0	9.0	10	125.0	60.50	13	2.68
52	52	40	34	19.0	25.1	20.0	11.0	10	250.0	123.00	20	4.40
52-2	52	40	34	19.0	25.1	20.0	11.0	10	125.0	60.50	20	4.40
52-4	52	40	34	17.0	25.1	24.0	13.0	10	62.5	29.25	20	4.40

### Ordering a guide rail

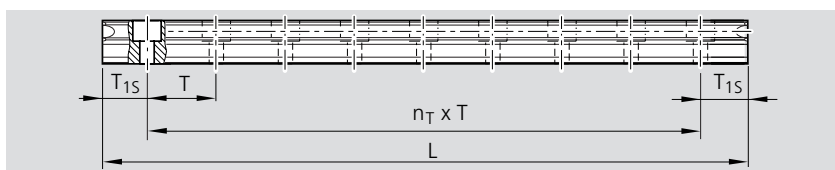

### Calculating guide rail length

Recommendation:

Use preferred length T<sub>1s</sub>.

- Observe minimum spacing T<sub>1 min</sub>! (see table)
- T<sub>1</sub> is the same at either end of the rail.

$$L = n_B \cdot T - 4$$

or

$$L = n_T \cdot T + 2 \cdot T_{1s}$$

L = rail length (mm)  
 T = hole spacing\*) (mm)  
 T<sub>1s</sub> = preferred dimension\*) (mm)  
 n<sub>B</sub> = number of holes  
 n<sub>T</sub> = number of spaces  
 \*) see table for values

### Ordering example

Guide rail: size 25  
 Desired length: 620 to 625 mm  
 $n_B = 620/T = 620/62.5 = 9.92$   
 rounded to whole numbers  
 = 10 holes,  
 $n_T = n_B - 1 = 9$

Rail ordering data:  
 Part number, length (mm)  
 T<sub>1</sub> / n<sub>T</sub> x T / T<sub>1</sub> (mm)  
**1921-125-31, 621**  
**29.25 / 9 x 62.5 / 29.25**

Mounting hole plug ordering data:  
 Part number, quantity  
**1605-800-90, 10**

### Length to be ordered

L = 10 · 62.5 - 4 = 621 mm or  
 L = 9 · 62.5 + 2 · 29.25 = 621 mm

# STAR – Cam Roller Guides

## Guide Rails

### Guide Rail with T-slot 1922-

- For mounting from below
- Washers supplied (quantity according to spacing T)
- Corrosion resistant steel shafts to DIN 17230 / EN 10088

**⚠** Standard Guide Rails are not suitable for use with the ALU-STAR Profile System. For guide rails with hole spacing  $T = 60$  mm for the ALU-STAR Profile System, see the ALU-STAR Profile System catalog 82 852.

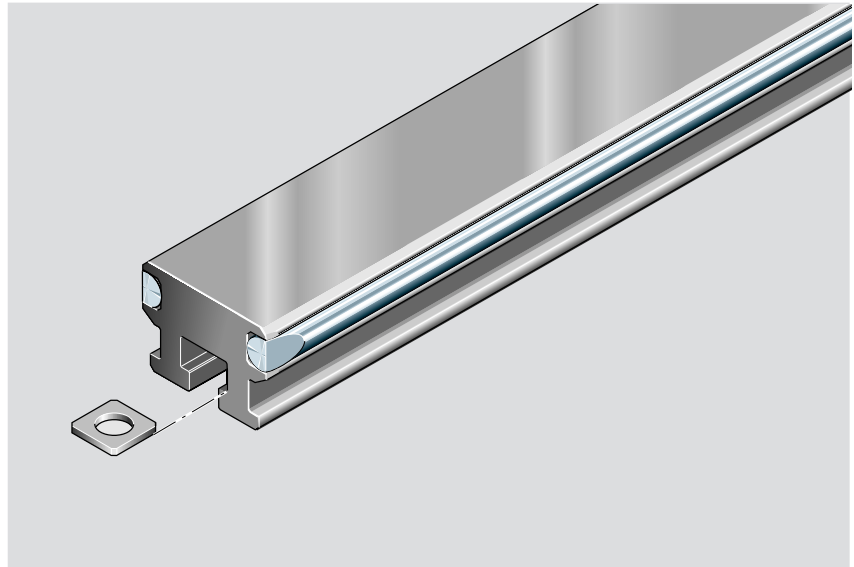

### Part numbers, lengths

Guide Rail with T-slot			
Size	Standard length <sup>1)</sup>	L <sub>max</sub> (mm)	Part number Length:,...(mm)
25	3500	7000	1922-025-31,...
32	3500	7000	1922-032-31,...
52	3500	7000	1922-052-31,...

<sup>1)</sup> Running tracks up to 3500 mm are made of one-piece precision steel shafts.



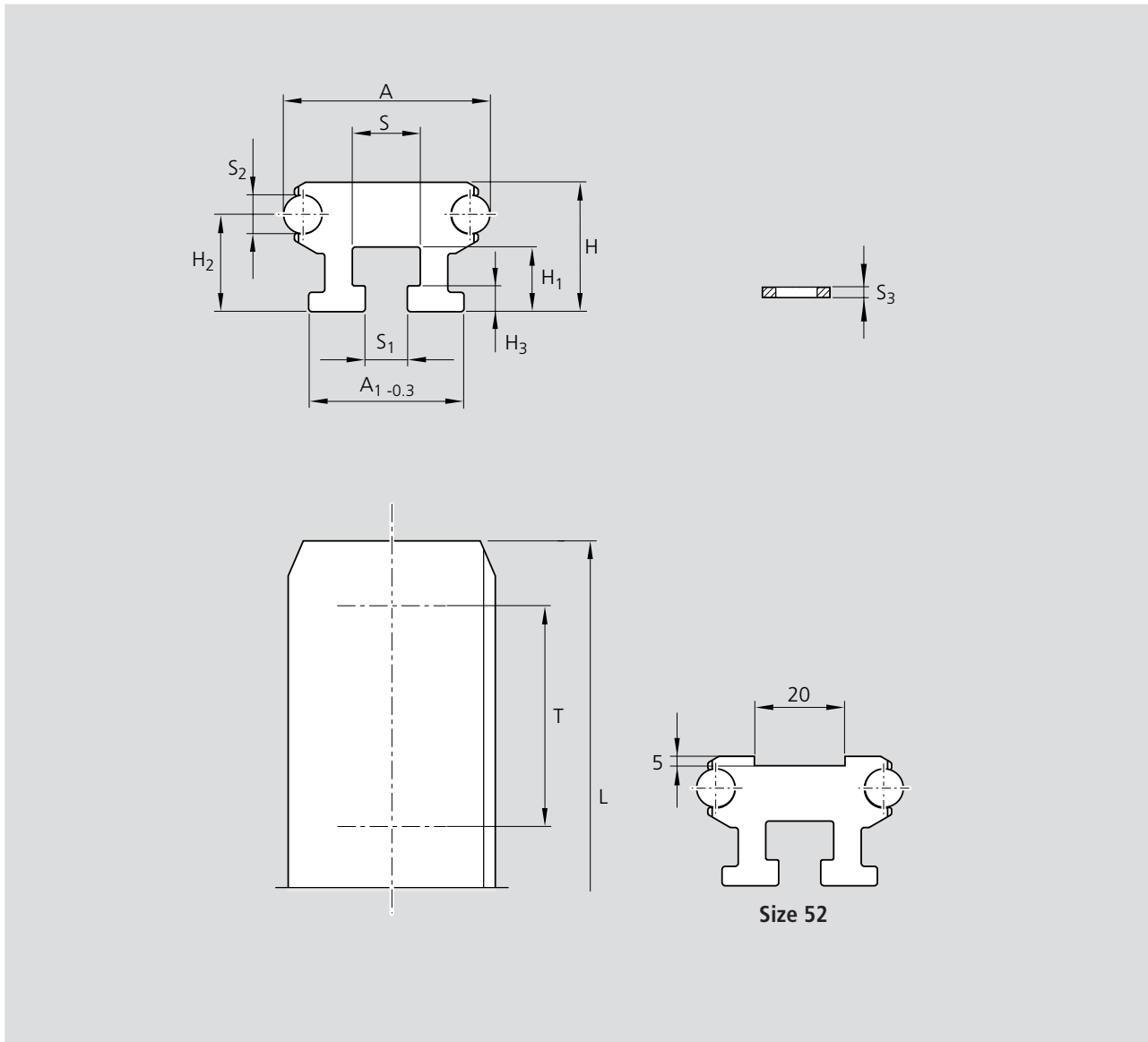

**Note**

See "Mounting Instructions, Guide Rail Mounting".

Size	Dimensions (mm)											Mass
	A	A <sub>1</sub>	H	H <sub>1</sub>	H <sub>2</sub>	H <sub>3</sub>	S	S <sub>1</sub>	S <sub>2</sub>	S <sub>3</sub>	T	kg/m
<b>25</b>	25	21	15	8.0	10.6	3.0	8.2	5.5	6	1.0	62.5	0.95
<b>32</b>	32	24	20	10.0	15.0	4.0	10.5	6.5	6	1.6	125.0	1.60
<b>52</b>	52	40	34	15.4	25.1	6.4	18.5	11.0	10	1.6	250.0	3.60

T = Maximum distance between mounting screws

# STAR – Cam Roller Guides

## Guide Rails

### Guide Rail, low profile 1924-

– Corrosion resistant steel shafts to  
DIN 17230 / EN 10088

**⚠** Standard Guide Rails are not suitable for use with the ALU-STAR Profile System. For guide rails with hole spacing  $T = 60$  mm for the ALU-STAR Profile System, see the ALU-STAR Profile System catalog 82 852.

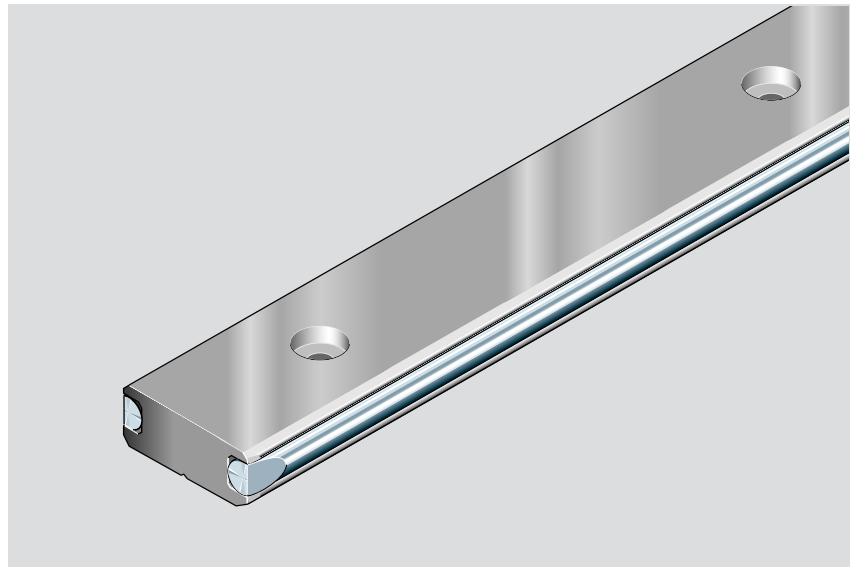

### Teilenummern und Längen

Guide Rail, low profile			without holes	with holes
Size	Standard length <sup>1)</sup> (mm)	L <sub>max</sub> (mm)	Part number Length;...(mm)	Part number Length;...(mm)
32	3500	7000	1924-032-31,...	1924-132-31,...
32-2	3500	7000	–	1924-232-31,...
52	3500	7000	1924-052-31,...	1924-152-31,...
52-2	3500	7000	–	1924-252-31,...
52-4	3500	7000	–	1924-452-31,...

<sup>1)</sup> Running tracks up to 3500 mm are made of one-piece precision steel shafts.

Recommended rail lengths					
Size - Version	Hole spacing T (mm)	Number of holes/Rail length L (mm)			
32-2, 52-4	62.5	2/121	10/621	18/1121	40/2496
		4/246	12/746	20/1246	50/3125
		6/371	14/871	24/1496	56/3496
		8/496	16/996	30/1871	
32, 52-2	125	2/246	10/1246	18/2246	28/3496
		4/496	12/1496	20/2496	
		6/746	14/1746	22/2746	
		8/996	16/1996	24/2996	
52	250	2/496	6/1496	14/3496	
		3/746	8/1996		
		4/996	10/2496		
		5/1246	12/2996		

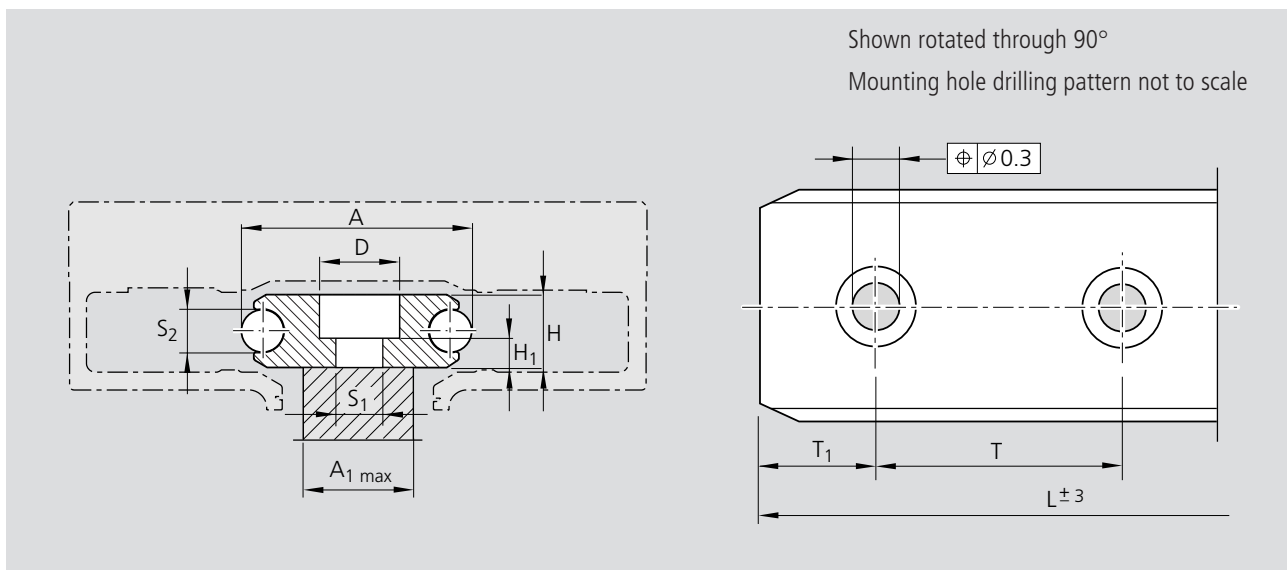

Size - Version	Dimensions (mm)											Mass kg/m
	A	A <sub>1 max</sub>	H	H <sub>1</sub>	H <sub>2</sub>	D	S <sub>1</sub>	S <sub>2</sub>	T	T <sub>1s</sub>	T <sub>1 min.</sub>	
32	32	19	10	3.5	5	11	6.5	6	125.00	60.50	13	1.1
32-2	32	19	10	3.5	5	11	6.5	6	62.50	29.25	13	1.1
52	52	32	18	7.0	9	20	11.0	10	250.00	123.00	20	3.1
52-2	52	32	18	7.0	9	20	11.0	10	125.00	60.50	20	3.1
52-4	52	32	18	7.0	9	20	11.0	10	62.50	29.25	20	3.1

### Ordering a guide rail

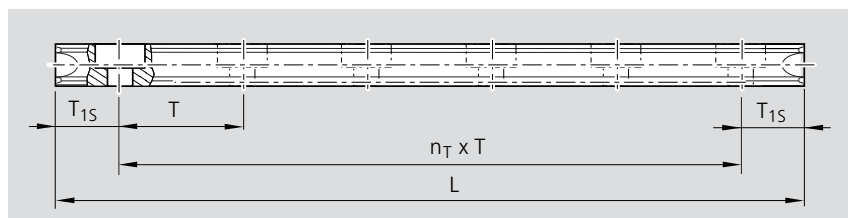

### Calculating guide rail length

Recommendation:

Use preferred length T<sub>1s</sub>.

- Observe minimum spacing T<sub>1 min</sub>! (see table)
- T<sub>1</sub> is the same at either end of the rail.

$$L = n_B \cdot T - 4$$

or

$$L = n_T \cdot T + 2 \cdot T_{1s}$$

L = rail length (mm)  
 T = hole spacing\*) (mm)  
 T<sub>1s</sub> = preferred dimension\*) (mm)  
 n<sub>B</sub> = number of holes  
 n<sub>T</sub> = number of spaces  
 \*) see table for values

### Ordering example

Guide rail: size 32-2

Desired length: 620 to 625 mm

$$n_B = 620/T = 620/62.5 = 9.92$$

rounded to whole numbers  
= 10 holes,

$$n_T = n_B - 1 = 9$$

Rail ordering data:

Part number, length (mm)

$$T_1 / n_T \times T / T_1 \text{ (mm)}$$

**1924-232-31, 621**

**29.25 / 9 x 62.5 / 29.25**

### Length to be ordered

$$L = 10 \cdot 62.5 - 4 = 621 \text{ mm} \quad \text{or}$$

$$L = 9 \cdot 62.5 + 2 \cdot 29.25 = 621 \text{ mm}$$

# STAR – Cam Roller Guides

## Single/Double Bearing Runner Blocks with Adjustment Screws

### Single Bearing Runner Blocks 1903-

#### Special features:

- Freely selectable carriage structure spacing.
- Zero-clearance adjustment using socket hex screws (1) on the rear side of the runner blocks.
- Tough all-round sealing gives excellent wiper performance.  
Grease lubricant recommended.

**⚠** Standard S/D Bearing Runner Blocks are not suitable for use with the ALU-STAR Profile System. For suitable runner blocks, see the ALU-STAR Profile System catalog 82 852.

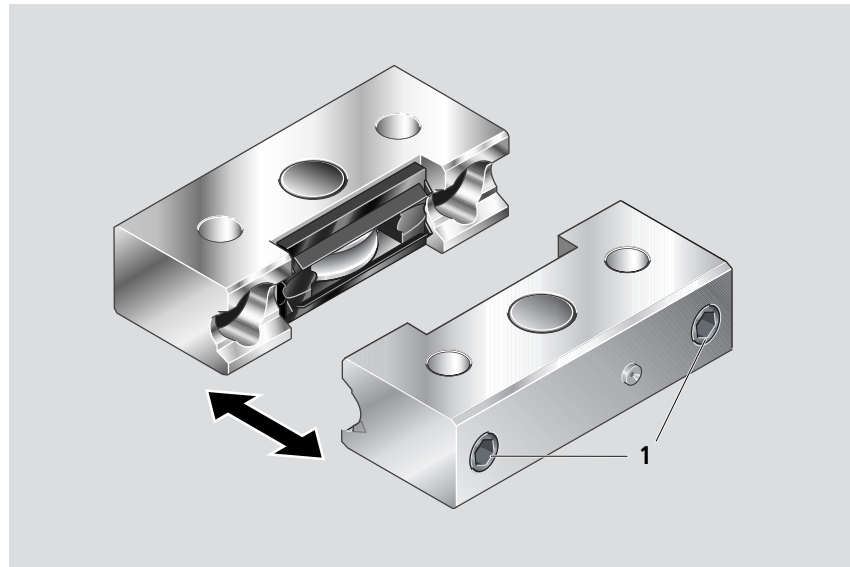

**Part numbers,  
Load capacities and moment loads for calculating service life  
when using four single bearing runner blocks**

Size - Version	Part number	Load capacities				Moment loads					
		$C_y$ (N)	$C_{y0}$ (N)	$C_z$ (N)	$C_{z0}$ (N)	$M_x$ (Nm)	$M_{x0}$ (Nm)	$M_y$ (Nm)	$M_{y0}$ (Nm)	$M_z$ (Nm)	$M_{z0}$ (Nm)
32	1903-132-10	7335	4560	4300	2200	$2.1 \cdot a$	$1.1 \cdot a$	$2.1 \cdot b$	$1.1 \cdot b$	$3.6 \cdot b$	$2.2 \cdot b$
52	1903-152-10	17150	10200	10050	4900	$5.0 \cdot a$	$2.4 \cdot a$	$5.0 \cdot b$	$2.4 \cdot b$	$8.5 \cdot b$	$5.1 \cdot b$
52-h	1903-252-10	27900	15400	16775	7630	$8.3 \cdot a$	$3.8 \cdot a$	$8.3 \cdot b$	$3.8 \cdot b$	$13.9 \cdot b$	$7.6 \cdot b$
52-sh	1903-352-10	31000	18200	18400	8750	$9.3 \cdot a$	$4.4 \cdot a$	$9.2 \cdot b$	$4.3 \cdot b$	$15.5 \cdot b$	$9.1 \cdot b$

### Advantage

The adjustment screws provide for zero-clearance running.

These screws can be used to rotate the runner block slightly about the z axis or shift it along the y axis to obtain optimal alignment.

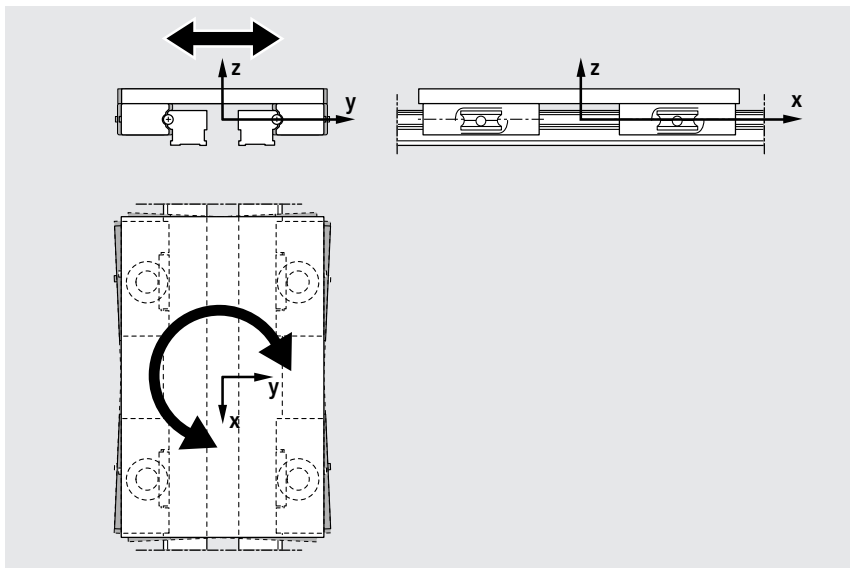

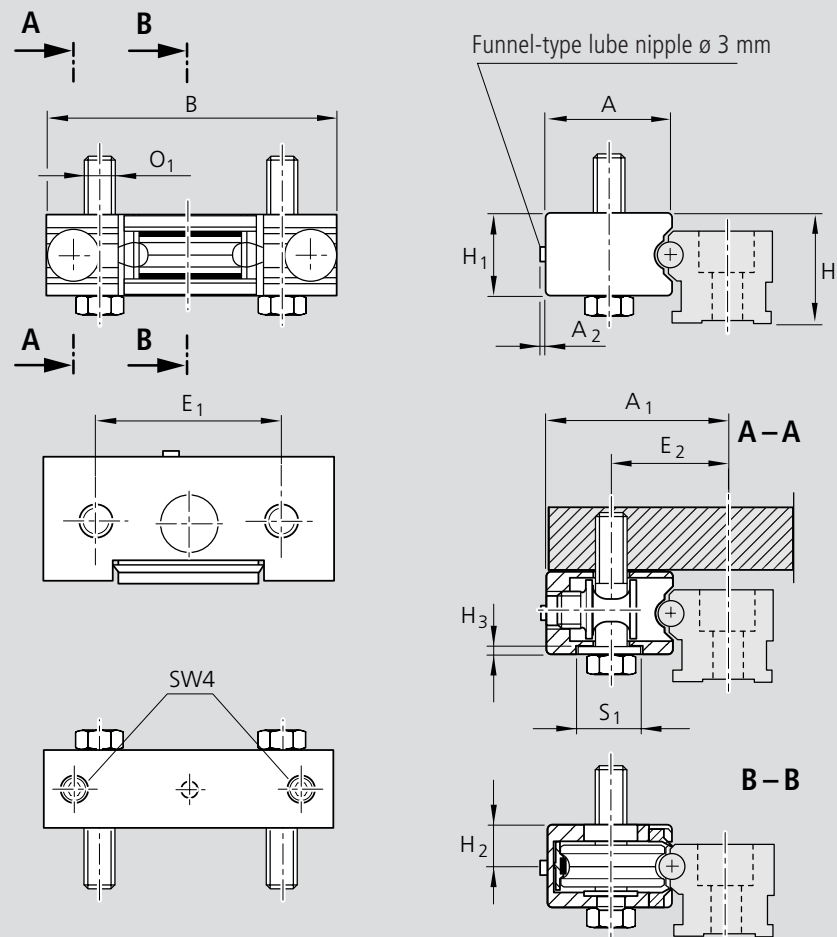

Size - Version	Dimensions (mm)											
	A	A <sub>1</sub>	A <sub>2</sub>	B	H	H <sub>1</sub>	H <sub>2</sub>	H <sub>3</sub>	E <sub>1</sub>	E <sub>2</sub>	S <sub>1</sub>	O <sub>1</sub> <sup>1)</sup>
32	31.0	43.0	2	87.0	26	20.5	11.0	2.5	54	27.0	18	M8
52	44.5	65.0	2	104.0	40	29.5	14.9	2.5	66	42.0	22	M10
52-h	52.0	72.5	2	118.5	42	33.5	16.9	3.0	76	45.0	26	M12
52-sh	57.0	77.5	2	123.5	42	33.5	16.9	3.0	81	47.5	26	M12

<sup>1)</sup> Mounting screws are not included in the supply.  
For screws to DIN 931-8.8, install a washer to DIN 125.

# STAR – Cam Roller Guides

## Double Bearing Runner Blocks 1904-

### Special features:

- Freely selectable carriage structure spacing.
- Zero-clearance adjustment using socket hex screws (1) on the rear side of the runner blocks.
- Tough all-round sealing gives excellent wiper performance.  
Grease lubricant recommended.

**⚠ Standard S/D Bearing Runner Blocks are not suitable for use with the ALU-STAR Profile System. For suitable runner blocks, see the ALU-STAR Profile System catalog 82 852.**

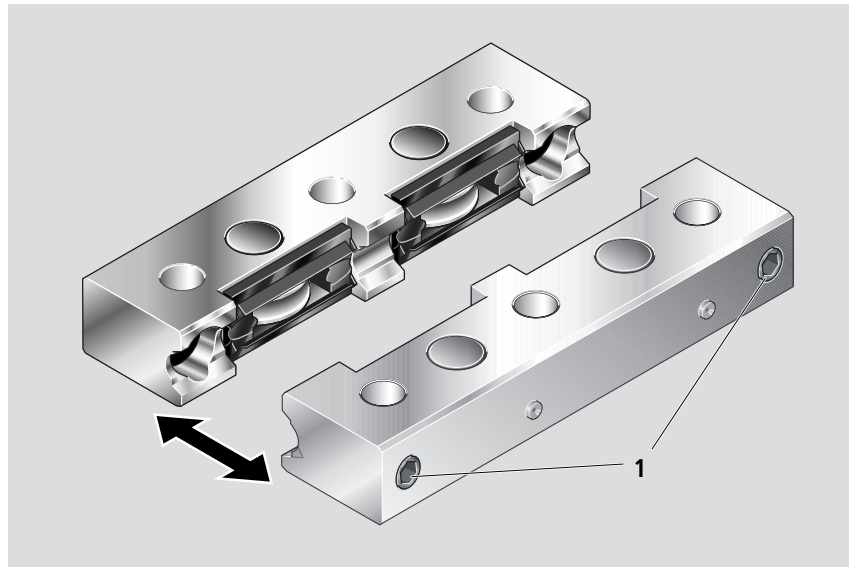

### Part numbers, Load capacities and moment loads for calculating service life when using two double bearing runner blocks

Size - Version	Part number	Load capacities				Moment loads					
		$C_y$ (N)	$C_{y0}$ (N)	$C_z$ (N)	$C_{z0}$ (N)	$M_x$ (Nm)	$M_{x0}$ (Nm)	$M_y$ (Nm)	$M_{y0}$ (Nm)	$M_z$ (Nm)	$M_{z0}$ (Nm)
32	1904-132-10	7335	4560	4300	2200	$2.1 \cdot a$	$1.1 \cdot a$	105	55	180	110
52	1904-152-10	17150	10200	10050	4900	$5.0 \cdot a$	$2.4 \cdot a$	330	158	561	337
52-h	1904-252-10	27900	15400	16775	7630	$8.3 \cdot a$	$3.8 \cdot a$	631	289	1056	578
52-sh	1904-352-10	31000	18200	18400	8750	$9.3 \cdot a$	$4.4 \cdot a$	740	350	1260	740

### Advantage

The adjustment screws provide for zero-clearance running.

These screws can be used to rotate the runner block slightly about the z axis or shift it along the y axis to obtain optimal alignment.

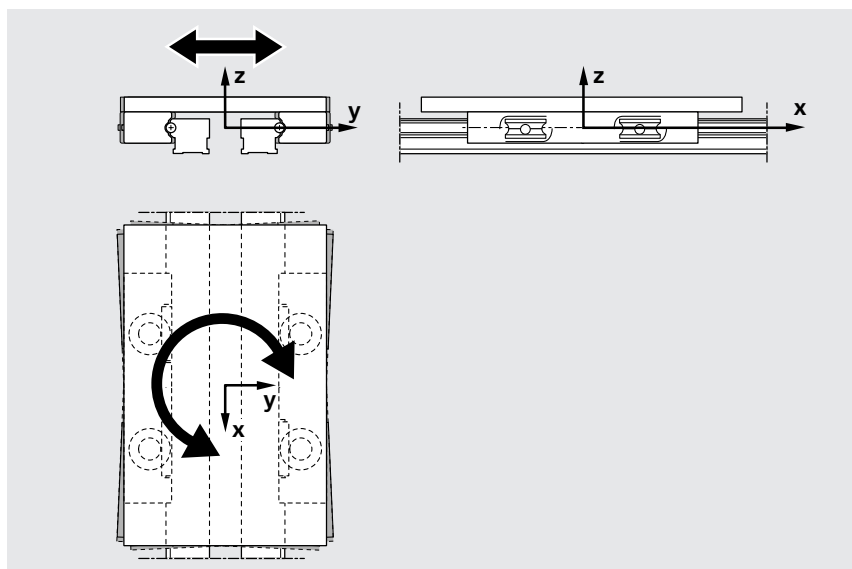

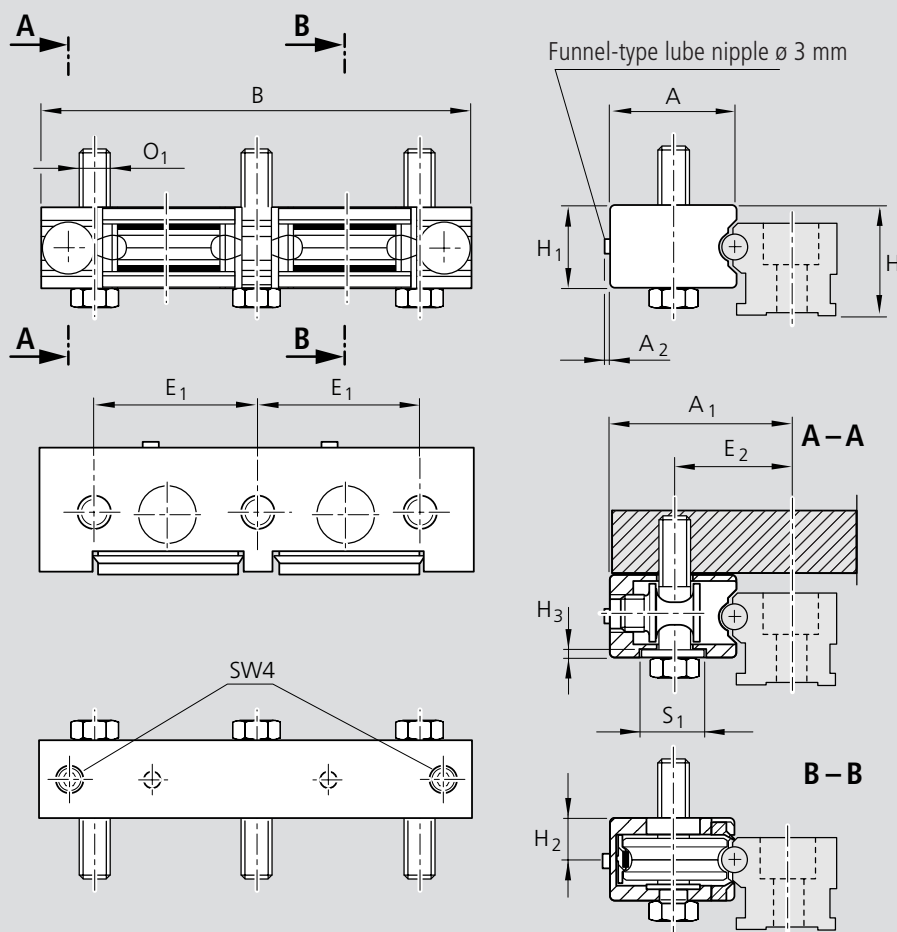

Size - Version	Dimensions (mm)											
	A	A <sub>1</sub>	A <sub>2</sub>	B	H	H <sub>1</sub>	H <sub>2</sub>	H <sub>3</sub>	E <sub>1</sub>	E <sub>2</sub>	S <sub>1</sub>	O <sub>1</sub> <sup>1)</sup>
<b>32</b>	31.0	43.0	2	129.0	26	20.5	11.0	2.5	48.0	27.0	18	M8
<b>52</b>	44.5	65.0	2	159.0	40	29.5	14.9	2.5	60.5	42.0	22	M10
<b>52-h</b>	52.0	72.5	2	184.5	42	33.5	16.9	3.0	71.0	45.0	26	M12
<b>52-sh</b>	57.0	77.5	2	194.5	42	33.5	16.9	3.0	76.0	47.5	26	M12

<sup>1)</sup> Mounting screws are not included in the supply.  
For screws to DIN 931-8.8, install a washer to DIN 125.

# STAR – Cam Roller Guides

## Guide Rails

### Guide Rail standard half-rail 1925-

- For mounting from above
- Optional mounting hole plugs
- Corrosion resistant steel shafts to DIN 17230 / EN 10088

**⚠** Standard Guide Rails are not suitable for use with the ALU-STAR Profile System. For guide rails with hole spacing  $T = 60$  mm for the ALU-STAR Profile System, see the ALU-STAR Profile System catalog 82 852.

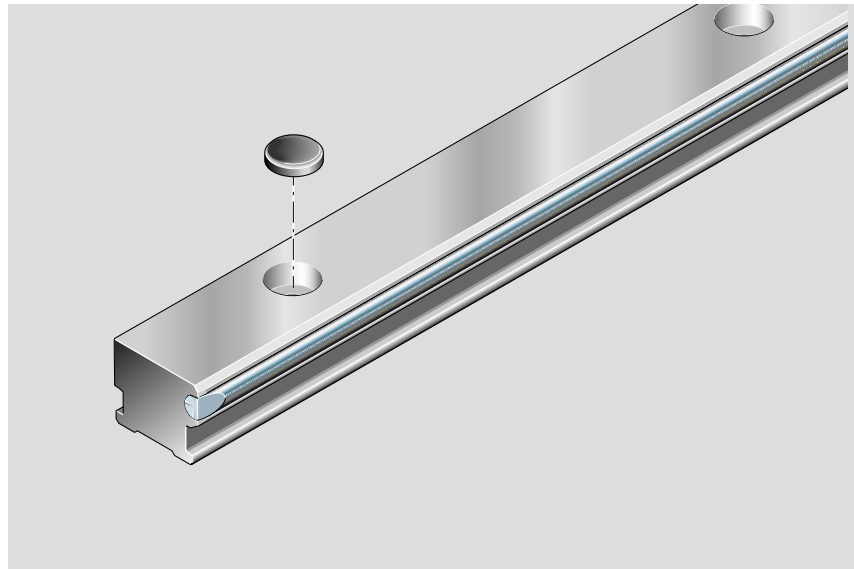

### Part numbers, lengths

Guide Rail: standard half-rail			without holes	with holes	Mounting hole plugs (optional)	
Size - Version	Standard length <sup>1)</sup> (mm)	L <sub>max</sub> (mm)	Part number Length:,...(mm)	Part number Length:,...(mm)	Part number Quantity:,...	Holes per meter <sup>2)</sup>
32	3500	7000	1925-032-31,...	1925-132-31,...	1605-200-90,...	8
32-2	3500	7000	–	1925-232-31,...	1605-200-90,...	16
52	3500	7000	1925-052-31,...	1925-152-31,...	1605-400-90,...	4
52-2	3500	7000	–	1925-252-31,...	1605-400-90,...	8
52-4	3500	7000	–	1925-452-31,...	1605-500-90,...	16

<sup>1)</sup> Running tracks up to 3500 mm are made of one-piece precision steel shafts.

<sup>2)</sup> Number for one meter at preferred length  $T_{15}$

Recommended rail lengths					
Size - Version	Hole spacing T (mm)	Number of holes/Rail length L (mm)			
32-2, 52-4	62.5	2/121	10/621	18/1121	40/2496
		4/246	12/746	20/1246	50/3125
		6/371	14/871	24/1496	56/3496
		8/496	16/996	30/1871	
32, 52-2	125	2/246	10/1246	18/2246	28/3496
		4/496	12/1496	20/2496	
		6/746	14/1746	22/2746	
		8/996	16/1996	24/2996	
52	250	2/496	6/1496	14/3496	
		3/746	8/1996		
		4/996	10/2496		
		5/1246	12/2996		



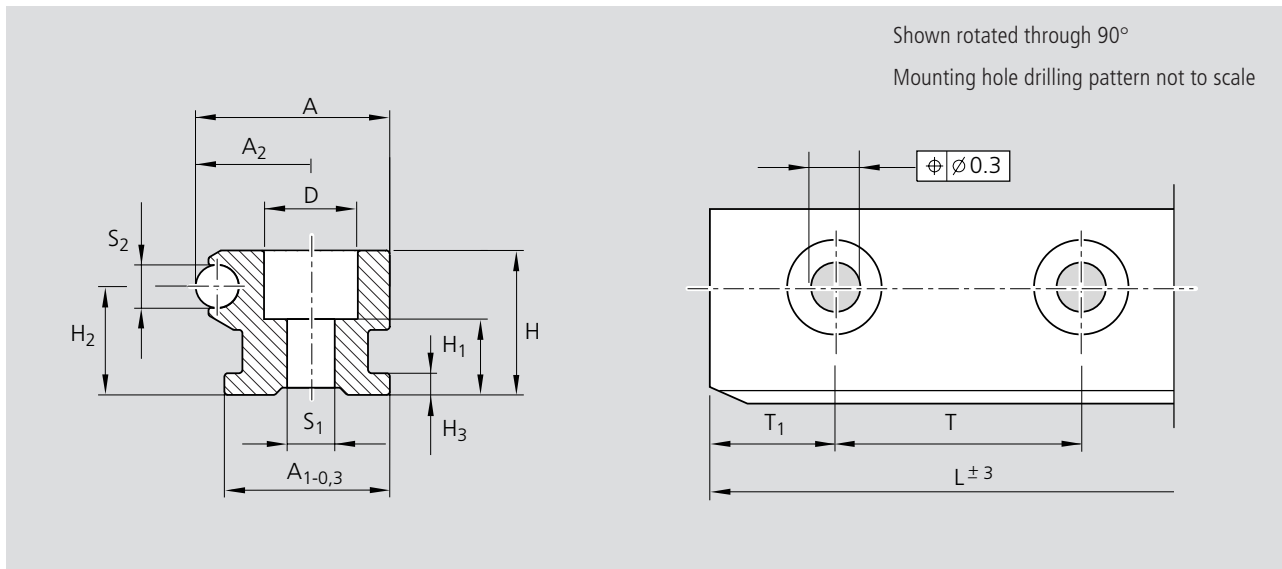

Size - Version	Dimensions (mm)													Mass
	A	A <sub>1</sub>	A <sub>2</sub>	H	H <sub>1</sub>	H <sub>2</sub>	H <sub>3</sub>	D	S <sub>1</sub>	S <sub>2</sub>	T	T <sub>15</sub>	T <sub>1 min.</sub>	kg/m
32	26	22	16	20	9.5	15.0	3	11.0	6.5	6	125.0	60.50	13	1.3
32-2	26	22	16	20	9.5	15.0	3	11.0	6.5	6	62.5	29.25	13	1.3
52	42	36	26	34	19.0	25.1	5	20.0	11.0	10	250.0	123.00	20	3.5
52-2	42	36	26	34	19.0	25.1	5	20.0	11.0	10	125.0	60.50	20	3.5
52-4	42	36	26	34	17.0	25.1	5	24.0	13.0	10	62.5	29.25	20	3.5

### Ordering a guide rail

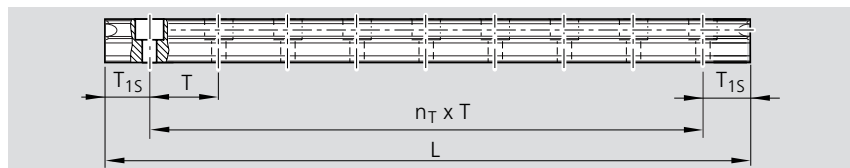

### Calculating guide rail length

Recommendation:

Use preferred length T<sub>15</sub>.

- Observe minimum spacing T<sub>1 min</sub>! (see table)
- T<sub>1</sub> is the same at either end of the rail.

$$L = n_B \cdot T - 4$$

or

$$L = n_T \cdot T + 2 \cdot T_{15}$$

L = rail length (mm)  
 T = hole spacing\*) (mm)  
 T<sub>15</sub> = preferred dimension\*) (mm)  
 n<sub>B</sub> = number of holes  
 n<sub>T</sub> = number of spaces  
 \*) see table for values

### Ordering example

Guide rail: size 32-2

Desired length: 620 to 625 mm

$$n_B = 620/T = 620/62.5 = 9.92$$

rounded to whole numbers  
= 10 holes,

$$n_T = n_B - 1 = 9$$

Rail ordering data:

Part number, length (mm)

T<sub>1</sub> / n<sub>T</sub> x T / T<sub>1</sub> (mm)

**1925-232-31, 621**

**29.25 / 9 x 62.5 / 29.25**

Mounting hole plug ordering data:

Part number, quantity

**1605-200-90, 10**

### Length to be ordered

$$L = 10 \cdot 62.5 - 4 = 621 \text{ mm} \quad \text{or}$$

$$L = 9 \cdot 62.5 + 2 \cdot 29.25 = 621 \text{ mm}$$

# STAR – Cam Roller Guides

## Guide Rails

### Guide Rail

#### low-profile, half-rail 1926-

- For mounting from above
- Corrosion resistant steel shafts to DIN 17230 / EN 10088

**⚠** Standard Guide Rails are not suitable for use with the ALU-STAR Profile System. For guide rails with hole spacing  $T = 60$  mm for the ALU-STAR Profile System, see the ALU-STAR Profile System catalog 82 852.

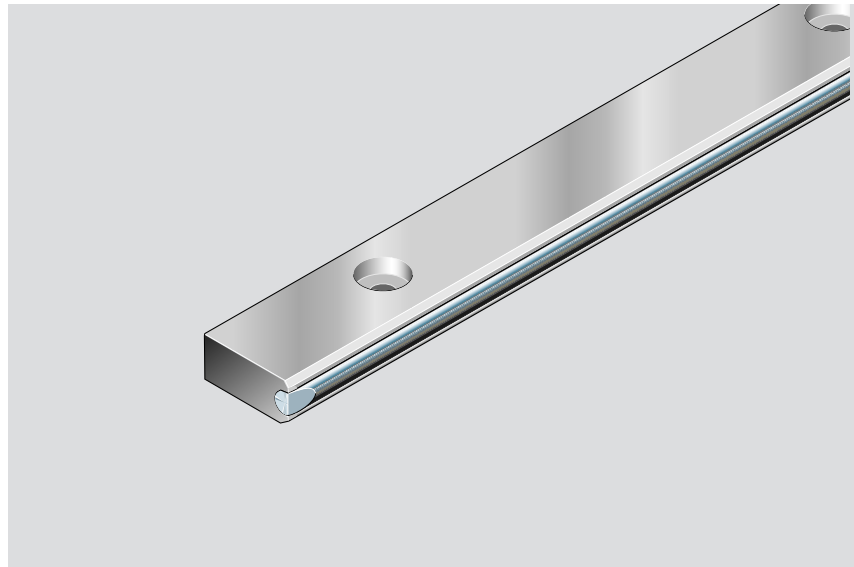

### Part numbers, lengths

Guide rail: low-profile, half-rail			without holes	with holes
Size	Standard length <sup>1)</sup> (mm)	L <sub>max</sub> (mm)	Part number Length;...(mm)	Part number Length;...(mm)
32	3500	7000	1926-032-31,...	1926-132-31,...
32-2	3500	7000	–	1926-232-31,...
52	3500	7000	1926-052-31,...	1926-152-31,...
52-2	3500	7000	–	1926-252-31,...
52-4	3500	7000	–	1926-452-31,...

<sup>1)</sup> Running tracks up to 3500 mm are made of one-piece precision steel shafts.

Recommended rail lengths					
Size - Version	Hole spacing T (mm)	Number of holes/Rail length L (mm)			
32-2, 52-4	62.5	2/121	10/621	18/1121	40/2496
		4/246	12/746	20/1246	50/3125
		6/371	14/871	24/1496	56/3496
		8/496	16/996	30/1871	
32, 52-2	125	2/246	10/1246	18/2246	28/3496
		4/496	12/1496	20/2496	
		6/746	14/1746	22/2746	
		8/996	16/1996	24/2996	
52	250	2/496	6/1496	14/3496	
		3/746	8/1996		
		4/996	10/2496		
		5/1246	12/2996		

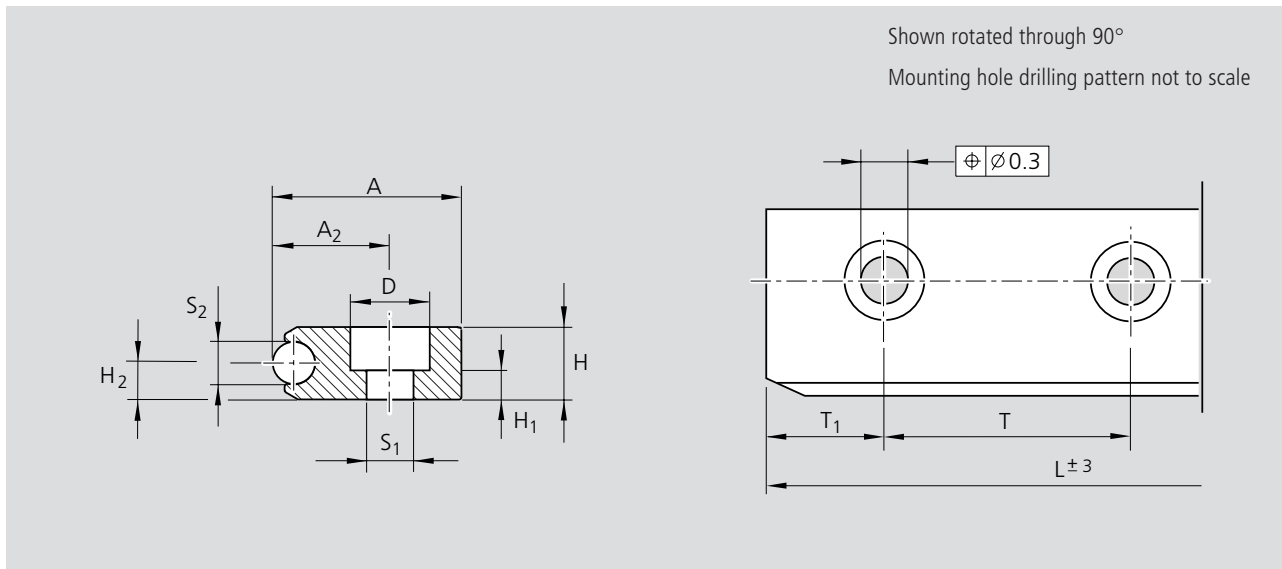

Size - Version	Dimensions (mm)											Mass kg/m
	A	A <sub>2</sub>	H	H <sub>1</sub>	H <sub>2</sub>	D	S <sub>1</sub>	S <sub>2</sub>	T	T <sub>1s</sub>	T <sub>1 min.</sub>	
32	26	16	10	3.5	5	11.0	6.5	6	125.0	60.50	13	0.8
32-2	26	16	10	3.5	5	11.0	6.5	6	62.5	29.25	13	0.8
52	42	26	18	7.0	9	20.0	11.0	10	250.0	123.00	20	2.3
52-2	42	26	18	7.0	9	20.0	11.0	10	125.0	60.50	20	2.3
52-4	42	26	18	7.0	9	24.0	13.0	10	62.5	29.25	20	2.3

### Ordering a guide rail

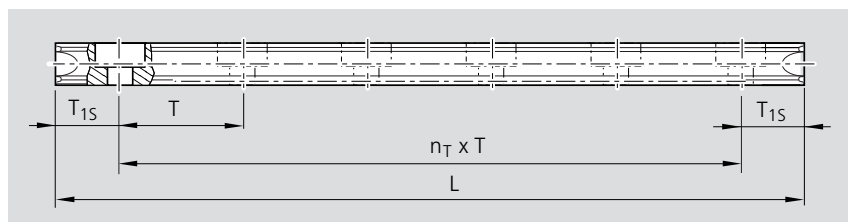

### Calculating guide rail length

Recommendation:

Use preferred length T<sub>1s</sub>.

- Observe minimum spacing T<sub>1 min</sub>! (see table)
- T<sub>1</sub> is the same at either end of the rail.

$L = n_B \cdot T - 4$ <p>or</p> $L = n_T \cdot T + 2 \cdot T_{1s}$	<p>L = rail length (mm)</p> <p>T = hole spacing*) (mm)</p> <p>T<sub>1s</sub> = preferred dimension*) (mm)</p> <p>n<sub>B</sub> = number of holes</p> <p>n<sub>T</sub> = number of spaces</p> <p>*) see table for values</p>
--	---

### Ordering example

Guide rail: size 32-2

Desired length: 620 to 625 mm

$$n_B = 620/T = 620/62.5 = 9.92$$

rounded to whole numbers  
= 10 holes,

$$n_T = n_B - 1 = 9$$

Rail ordering data:

Part number, length (mm)

$$T_1 / n_T \times T / T_1 \text{ (mm)}$$

**1926-232-31, 621**

**29.25 / 9 x 62.5 / 29.25**

### Length to be ordered

$$L = 10 \cdot 62.5 - 4 = 621 \text{ mm} \quad \text{or}$$

$$L = 9 \cdot 62.5 + 2 \cdot 29.25 = 621 \text{ mm}$$

# STAR – Cam Roller Guides

## Guide Rails

### Guide Rail wide 1927-

- For mounting from above
- Optional mounting hole plugs
- Corrosion resistant steel shafts to DIN 17230 / EN 10088

**⚠** Standard Guide Rails are not suitable for use with the ALU-STAR Profile System. For guide rails with hole spacing  $T = 180$  mm for the ALU-STAR Profile System, see the ALU-STAR Profile System catalog 82 852.

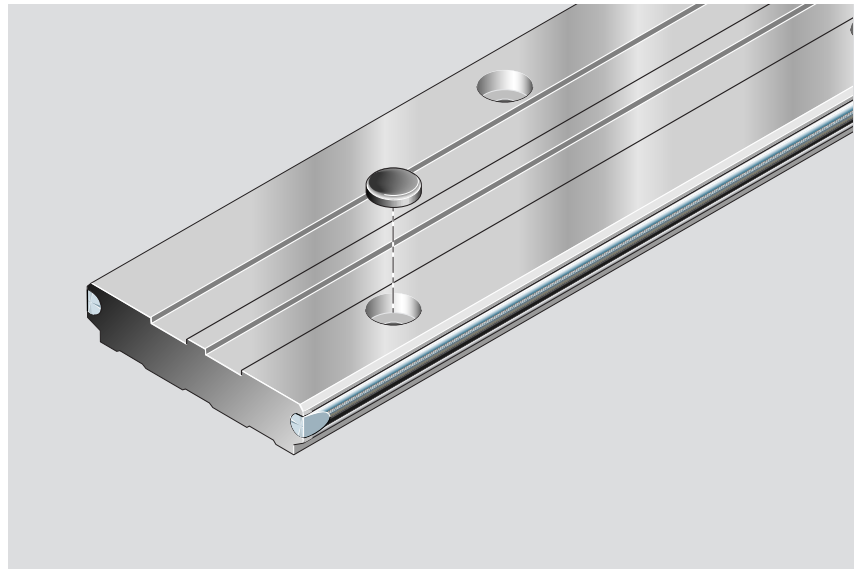

### Part numbers, lengths

Guide rail: wide			without holes	with holes	Mounting hole plugs (optional)	
Size - Version	Standard length <sup>1)</sup> (mm)	$L_{max}$ (mm)	Part number Length:,...(mm)	Part number Length:,...(mm)	Part number Quantity:,...	Holes per meter <sup>2)</sup>
52/120	3500	7000	1927-052-31,...	1927-152-31,...	1605-400-90,...	8

<sup>1)</sup> Running tracks up to 3500 mm are made of one-piece precision steel shafts.

<sup>2)</sup> Number for one meter at preferred length

### Ordering a guide rail

Wherever possible, use the recommended rail lengths (1.).

Intermediate lengths (2.) or special lengths (3.) may also be manufactured on request.

$L$	= rail length	(mm)
$n_B$	= number of holes	(both rows)
$n_T$	= number of spaces between holes	( $n_T = n_B - 1$ )
$T_1, T_2$	= end spaces, see drawings	(mm)
$T$	= hole spacing	(125 mm)

### Ordering data

#### 1. Recommended rail length:

Odd number of holes  $n_B$

$$T_1 \neq T_2$$

Preferred dimensions  $T_1$ : 60.5 mm,  
 $T_2$ : 185.5 mm

By turning the rail over it is possible to alternate between mounting hole pattern 1a) and 1b). When this is done,  $T_1$  becomes  $T_2$  and vice versa.

#### Calculating the rail length

- Observe minimum spacing  $T_{1,2 \min}$ ! (see table)

Rail ordering data:

**Part number, length  $L$  (mm)**

$$T_1 / n_T \times T / T_2 \text{ (mm)}$$

1 a)

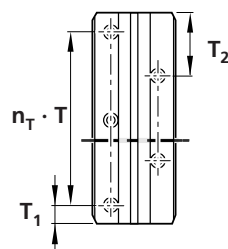

Mounting hole plug ordering data:

**Part number, quantity =  $n_B$**

**Example: 1605-400-90, 11**

1 b)

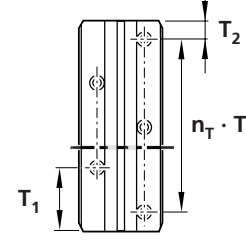

- |     |                           |
|-----|---------------------------|
| (1) | $L = n_B \cdot 125 - 4$   |
|     | or                        |
| (2) | $L = n_T \cdot 125 + 121$ |

Example

- |     |                                     |
|-----|-------------------------------------|
| (1) | $L = 11 \cdot 125 - 4 = 1371$ mm or |
| (2) | $L = 10 \cdot 125 + 121 = 1371$ mm  |

### Ordering example for recommended rail length

**1927-152-31, 1371**  
**60.5 / 10 x 125 / 185.5**

Number of holes  $n_B = 11$   
Number of spaces between holes  $n_T = 10$



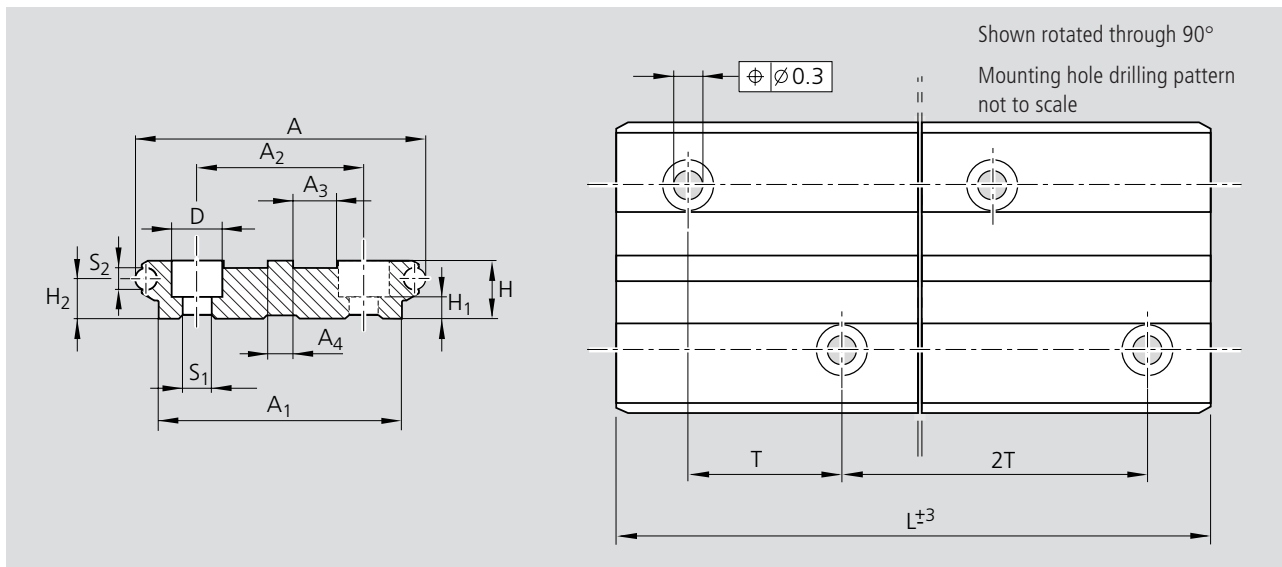

Size	Dimensions (mm)													Mass
	- Version	A	A <sub>1</sub>	A <sub>2</sub>	A <sub>3</sub>	A <sub>4</sub>	H	H <sub>1</sub>	H <sub>2</sub>	D	S <sub>1</sub>	S <sub>2</sub>	T	
52/120	120	100	68	18	10	25	10	16.1	20	11	10	125	13	7.8

## 2. Intermediate length:

### Even number of holes $n_B$

The mounting hole drilling pattern remains the same when the rail is turned over. Dimensions  $T_1$  and  $T_2$  remain the same and can therefore not be matched to a different pre-drilled hole pattern.

$T_1 = T_2 = 60.5$  mm or

$T_1 = T_2 = 185.5$  mm

(preferred dimensions)

Calculate the length according to item 1.  
"Recommended rail length"

2 a)

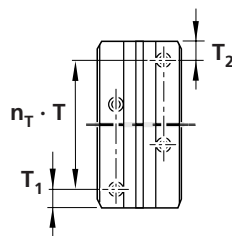

Ordering example: Rail 2a:

1927-152-31, 1496 mm  
60.5 / 11 x 125 / 60.5

2 b)

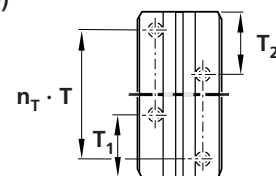

Ordering example: Rail 2b:

1927-152-31, 1496 mm  
185.5 / 11 x 125 / 185.5

## 3. Special length:

### Odd (3a) or even (3b) number of holes $n_B$

If the preferred dimensions  $T_1$  and  $T_2$  cannot be used (neither the recommended rail lengths nor intermediate lengths), determine  $T_1$  and  $T_2$  as required.

$T_1$  and  $T_2$  must not fall within the following ranges:

0 to 13 and 112 to 139 mm

3 a)

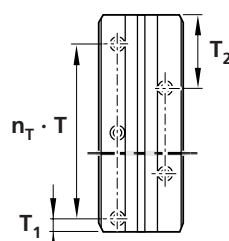

Ordering example: Rail 3a:

1927-152-31, 1305 mm  
20 / 10 x 125 / 160

3 b)

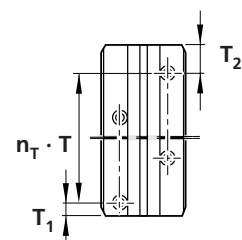

Ordering example: Rail 3b:

1927-152-31, 1435 mm  
20 / 11 x 125 / 40

# STAR – Cam Roller Guides

## U-type Runner Blocks

U-type Runner Block 1905-

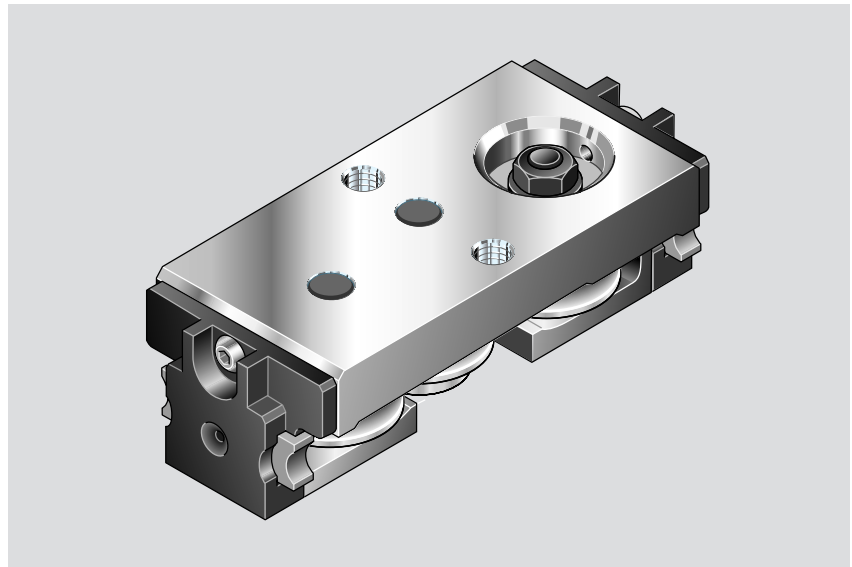

Part numbers,  
load capacities and moments for calculating service life

Size - Version	Part number	Load capacities and moments									
		$C_y$ (N)	$C_{y0}$ (N)	$C_z$ (N)	$C_{z0}$ (N)	$M_x$ (Nm)	$M_{x0}$ (Nm)	$M_y$ (Nm)	$M_{y0}$ (Nm)	$M_z$ (Nm)	$M_{z0}$ (Nm)
20	1905-119-00	1150	800	668	392	4.8	2.8	11.3	6.6	19.5	13.5

**Important:** Observe maximum permissible loads due to forces and moments as shown in the "Maximum Permissible Loads" tables!

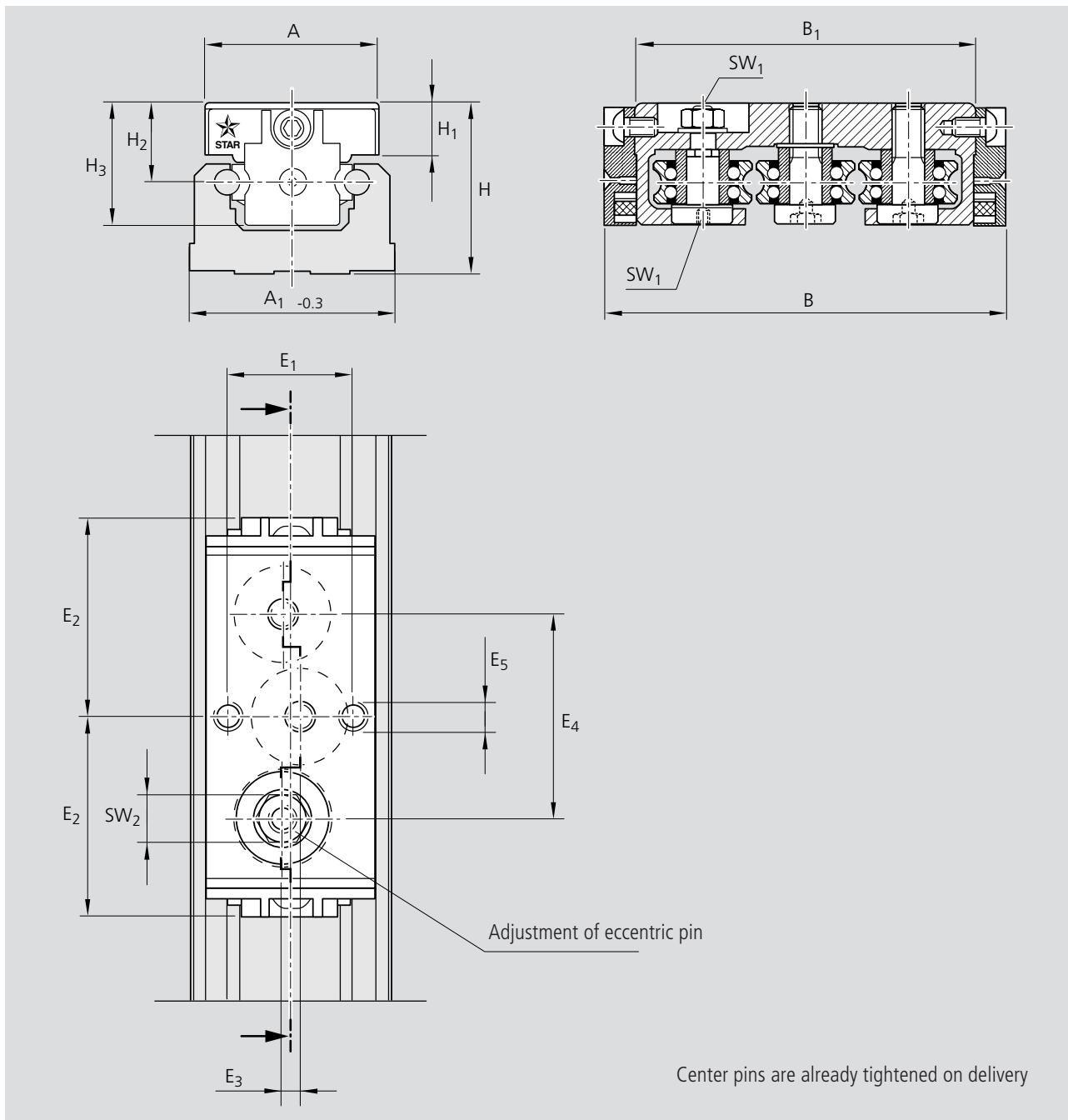

Size - Version	Dimensions (mm)															Mass (kg)
	A	A <sub>1</sub>	B	B <sub>1</sub>	H	H <sub>1</sub>	H <sub>2</sub>	H <sub>3</sub>	E <sub>1</sub>	E <sub>2</sub>	E <sub>3</sub>	E <sub>4</sub>	E <sub>5</sub>	SW <sub>1</sub>	SW <sub>2</sub>	
20	28	33	66	56	28	8.5	13	20	20	33	3	34	M5	2	7	0.08

# STAR – Cam Roller Guides

## U-type Guide Rails

### U-type Guide Rail 1923-

- For mounting from above
- Corrosion resistant steel shafts to DIN 17230 / EN 10088

**⚠** Standard Guide Rails are not suitable for use with the ALU-STAR Profile System. For guide rails with hole spacing  $T = 60$  mm for the ALU-STAR Profile System, see the ALU-STAR Profile System catalog 82 852.

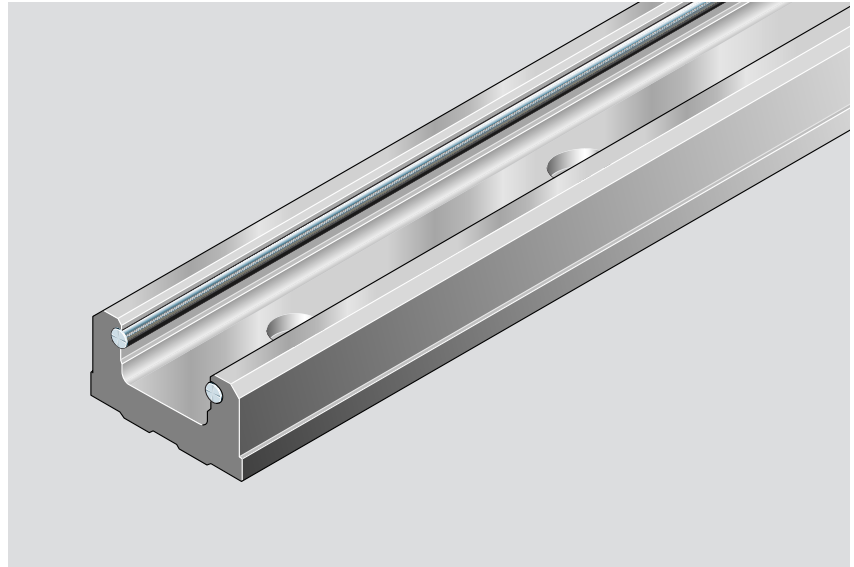

### Part numbers, lengths

Guide Rail: U-type		without holes	with holes
Size	Standard length <sup>1)</sup> (mm)	L <sub>max</sub> (mm)	Part number Length:,...(mm)
20	3500	7000	1923-019-31,...
			1923-119-31,...

<sup>1)</sup> Running tracks up to 3500 mm are made of one-piece precision steel shafts.

Size - Version	Hole spacing T (mm)	Recommended rail lengths			
		Number of holes/Rail length L (mm)			
20	62.5	2/121	10/621	18/1121	40/2496
		4/246	12/746	20/1246	50/3125
		6/371	14/871	24/1496	56/3496
		8/496	16/996	30/1871	



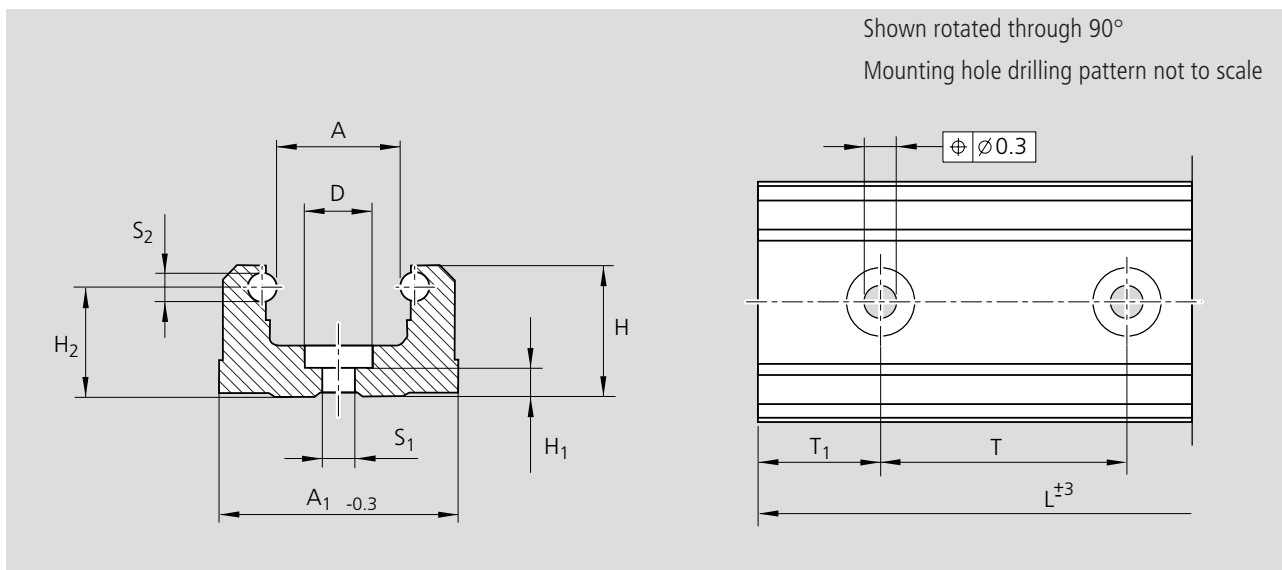

Dimensions (mm)												Mass
Size - Version	A	A <sub>1</sub>	H	H <sub>1</sub>	H <sub>2</sub>	D	S <sub>1</sub>	S <sub>2</sub>	T	T <sub>1S</sub>	T <sub>1 min.</sub>	kg/m
20	17	33	18	3.4	15	9.4	4.5	4	62.5	29.25	13	1.10

### Ordering a guide rail

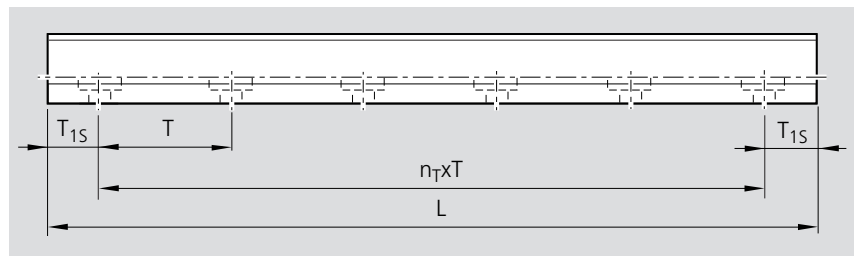

### Calculating guide rail length

Recommendation:

Use preferred length T<sub>1S</sub>.

- Observe minimum spacing T<sub>1 min</sub>! (see table)
- T<sub>1</sub> is the same at either end of the rail.

$$L = n_B \cdot T - 4$$

or

$$L = n_T \cdot T + 2 \cdot T_{1S}$$

L = rail length (mm)  
 T = hole spacing\*) (mm)  
 T<sub>1S</sub> = preferred dimension\*) (mm)  
 n<sub>B</sub> = number of holes  
 n<sub>T</sub> = number of spaces  
 \*) see table for values

### Ordering example

Guide rail: size 20  
 Desired length: 620 to 625 mm  
 $n_B = 620/T = 620/62.5 = 9.92$   
 rounded to whole numbers  
 = 10 holes,  
 $n_T = n_B - 1 = 9$

Rail ordering data:  
 Part number, length (mm)  
 T<sub>1</sub> / n<sub>T</sub> x T / T<sub>1</sub> (mm)  
**1923-119-31, 621**  
**29.25 / 9 x 62.5 / 29.25**

### Length to be ordered

$$L = 10 \cdot 62.5 - 4 = 621 \text{ mm} \quad \text{or}$$

$$L = 9 \cdot 62.5 + 2 \cdot 29.25 = 621 \text{ mm}$$

# STAR – Cam Roller Guides

## Accessories

### Dead stop 1910-5..-00

The dead stop can be used with guide rails 1921- (standard), 1922- (with T-slot) and 1924 (low-profile).

Holding force: 1500 N

If a set screw to ISO 7434 is used without a soft-metal pin, there will be a pressure point in the guide rail.

The resulting contour locking effect will increase the holding force.

The lubrication unit is reinforced in the area corresponding to the dead stop.

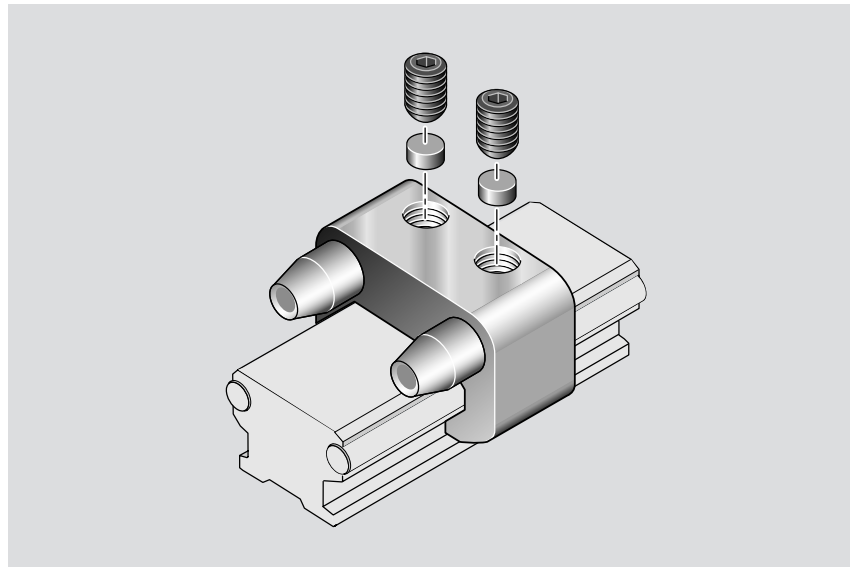

Size	Dead stop	For guide rails:
	Part number	Part number
32	1910-532-00,...	1921-, 1922-, 1924-
52	1910-552-00,...	1921-, 1922-, 1924-

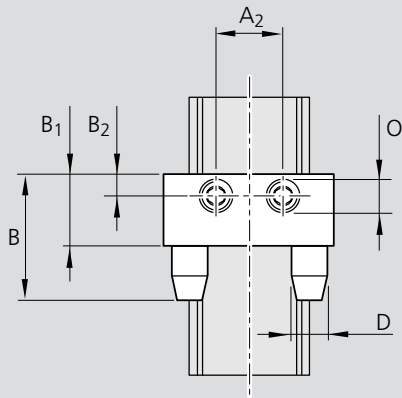
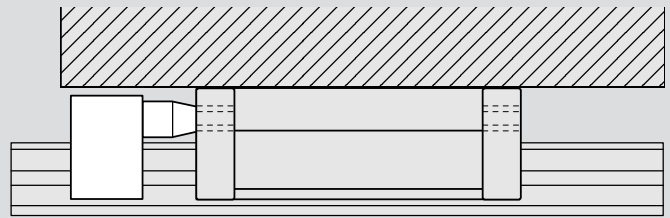
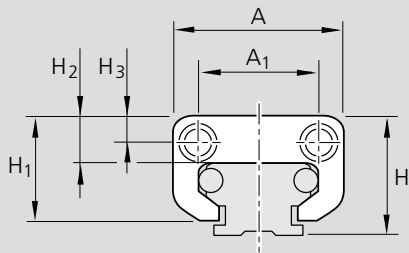

Size - Version	Dimensions (mm)												Mass (kg)
	A	A <sub>1</sub>	A <sub>2</sub>	B	B <sub>1</sub>	B <sub>2</sub>	D	H	H <sub>1</sub>	H <sub>2</sub>	H <sub>3</sub>	O	
32	46	33	18	35	20	5.5	10	33.5	29	13	7.5	M8	0.05
52	70	46	32	43	23	5.5	16	53.0	42	18	9.0	M8	0.11

# STAR – Cam Roller Guides

## Cam Rollers with Spigots, Assembly Kits

### Cam Roller with eccentric spigot 1900-...-0

For mounting customer-built carriages, with central and eccentric spigots for zero-clearance adjustment to the guide rail.



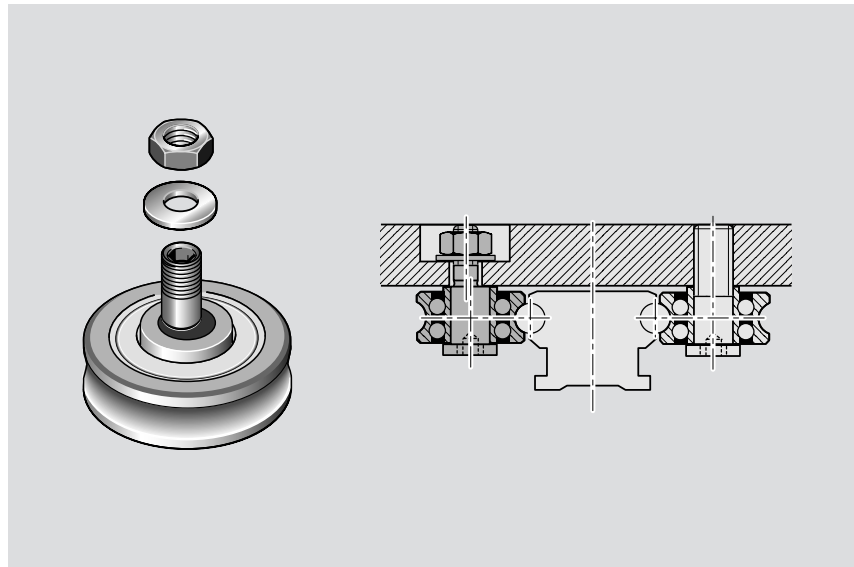

For applications where even the versatile standard range does not offer the optimum solution to your problem.



### Part numbers

#### Load capacities for calculating service life

#### Maximum permissible loads

Size - Version	Part number	Load capacities				Maximum permissible loads	
		 $C_y$ (N)	$C_{y0}$ (N)	 $C_z$ (N)	$C_{z0}$ (N)	 $F_{y \max}$ (N)	 $F_{z \max}$ (N)
20	1900-119-00	1150	800	330	190	350	100
25	1900-125-00	1280	890	340	200	350	100
32	1900-132-00	3670	2280	1080	550	550	180
52	1900-152-00	8580	5100	2510	1230	2500	700
52-h	1900-152-10	13950	7700	4190	1910	2600	800
52-sh	1900-152-20	15500	9100	4600	2190	5300	1600

## Dimensions

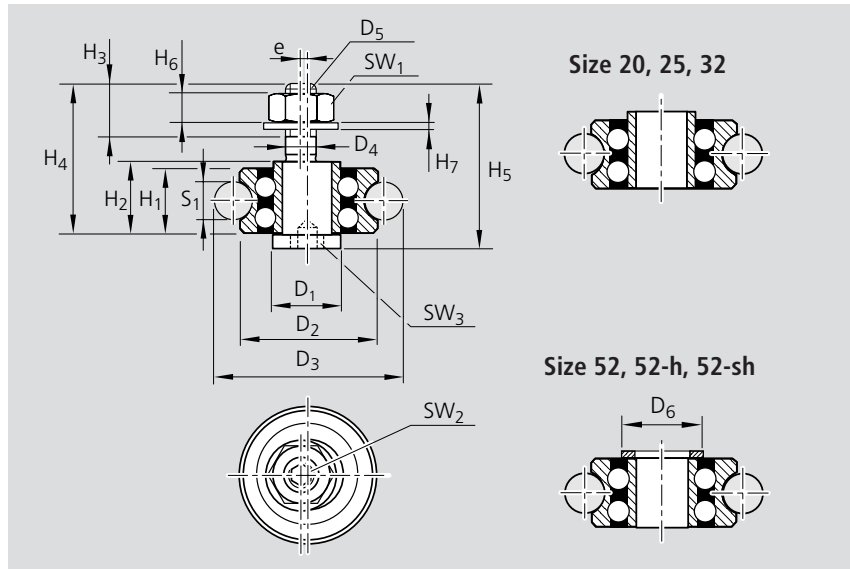

Size - Version	Dimensions (mm)																		
	$D_1$	$D_2$	$D_3$	$D_4$	$D_5$	$D_6$	$H_1$	$H_2$	$H_3$	$H_4$	$H_5$	$H_6$	$H_7$	$SW_1$	$SW_2$	$SW_3$	$e$	$s_1$	
	g6			g6															
20	10	16	22.0	4	M4	9.0	7.0	8.5	4.6	16.0	19.5	3.2	0.8	7	2	2	0.45	4	
25	10	17	27.0	4	M4	9.0	7.0	8.5	5.5	17.4	21.4	3.2	0.8	7	2	2	0.45	6	
32	14	24	34.0	6	M6	11.8	11.0	12.5	7.0	25.5	29.0	5.2	1.6	10	3	4	0.90	6	
52	20	35	51.3	10	M10	19.0	15.9	17.9	11.0	36.5	41.5	8.4	2.0	16	4	6	0.90	10	
52-h	20	42	58.0	10	M10	19.0	19.0	21.0	11.0	44.3	50.3	8.4	2.0	16	4	6	0.90	10	
52-sh	25	47	63.3	12	M12	24.0	19.0	21.0	13.0	44.3	50.3	10.8	2.5	18	6	8	0.90	10	

## Recommended hole spacing when using the following STAR Cam Roller Guide Rails:

- Standard 1921-
- With T-slot 1922-
- Low-profile 1924-

The drawing shows a cross-section of the cam roller guide rail assembly with dimensions  $D_7$ ,  $E_3$ , and  $H_8$  indicated.

Size - Version	$E_3$ $\pm 0.2$	$D_7$	$H_8$
20	33.8	15	3.0
25	39.8	15	3.6
32	54.0	18	5.5
52	83.3	30	7.3
52-h	90.0	30	11.8
52-sh	95.0	34	9.3

# STAR – Cam Roller Guides

## Cam Rollers with Spigots, Assembly Kits

### Cam Roller with central spigot 1900-...-1

For mounting customer-built carriages, with central and eccentric spigots for zero-clearance adjustment to the guide rail.

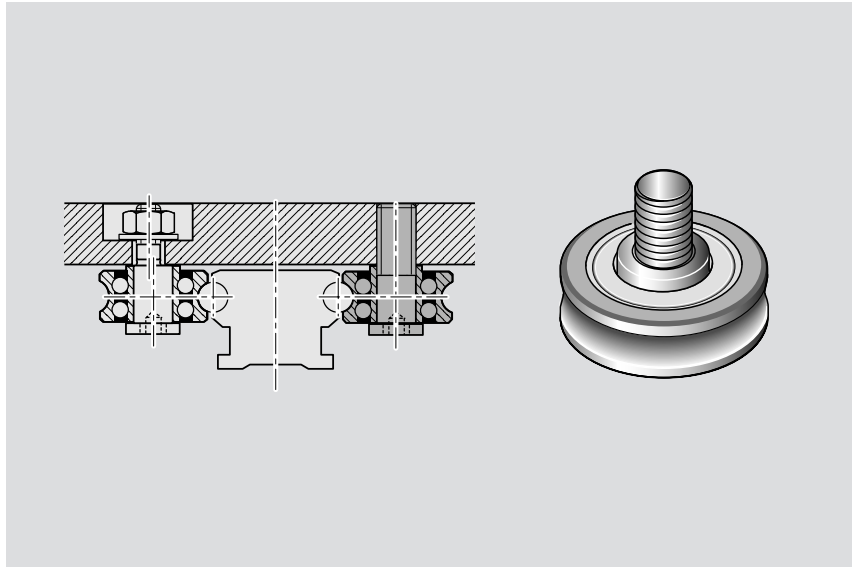

For applications where even the versatile standard range does not offer the optimum solution to your problem.



### Part numbers

Load capacities for calculating service life

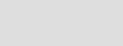
Maximum permissible loads

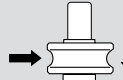
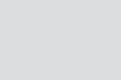
Size - Version	Part number	Load capacities				Maximum permissible loads	
		 $C_y$ (N)	 $C_{y0}$ (N)	 $C_z$ (N)	 $C_{z0}$ (N)	 $F_{y \max}$ (N)	 $F_{z \max}$ (N)
20	1900-119-01	1150	800	330	190	350	100
25	1900-125-01	1280	890	340	200	350	100
32	1900-132-01	3670	2280	1080	550	550	180
52	1900-152-01	8580	5100	2510	1230	2500	700
52-h	1900-152-11	13950	7700	4190	1910	2600	800
52-sh	1900-152-21	15500	9100	4600	2190	5300	1600

## Dimensions

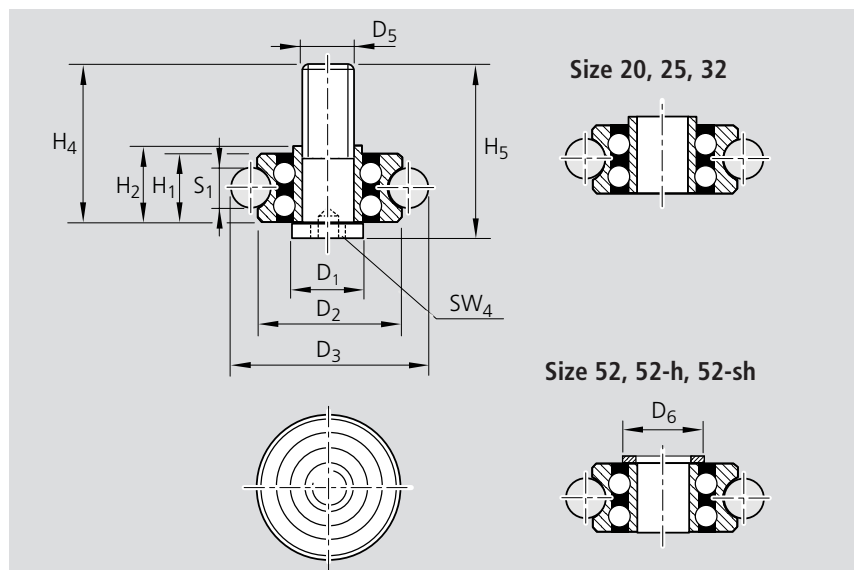

Size - Version	Dimensions (mm)															
	D <sub>1</sub> g6	D <sub>2</sub>	D <sub>3</sub>		D <sub>5</sub>	D <sub>6</sub>	H <sub>1</sub>	H <sub>2</sub>		H <sub>4</sub>	H <sub>5</sub>			SW <sub>4</sub>	s <sub>1</sub>	
20	10	16	22.0		M5	9.0	7.0	8.5		16.0	19.5			4	0.45	4
25	10	17	27.0		M5	9.0	7.0	8.5		17.4	21.4			4	0.45	6
32	14	24	34.0		M8	11.8	11.0	12.5		25.5	29.0			5	0.90	6
52	20	35	51.3		M10	19.0	15.9	17.9		36.5	41.5			8	0.90	10
52-h	20	42	58.0		M12	19.0	19.0	21.0		44.3	50.3			8	0.90	10
52-sh	25	47	63.3		M12	24.0	19.0	21.0		44.3	50.3			10	0.90	10

## Recommended hole spacing when using the following STAR Cam Roller Guide Rails:

- Standard 1921-
- With T-slot 1922-
- Low-profile 1924-

Size - Version	E <sub>3</sub> ± 0.2
20	33.8
25	39.8
32	54.0
52	83.3
52-h	90.0
52-sh	95.0

Great care has been taken during the compilation of this publication to ensure all the information contained is accurate. We accept no responsibility however for any damage resulting from incorrect or incomplete information contained.

For deliveries and other services in the course of commercial business, the general terms and conditions for supplies and services contained in the valid price lists and the confirmations of order apply.

As our products are constantly in the process of further development, they are subject to alteration without notice.

STAR, Ball Rail and  are trademarks registered for Deutsche Star GmbH, Germany.

Roller Rail is a trademark of Deutsche Star GmbH, Germany.

Reproduction of this document, even in extract form, is only permitted with our approval.

#### **Deutsche Star GmbH**

D-97419 Schweinfurt

Telephone +49-9721-937-0

Telefax +49-9721-937-275  
(general)

Telefax +49-9721-937-250  
(direct)

Cam Roller Guides

RE 82 101/04.99