

ALUMINUM TELESCOPIC RAILS

LTA34BT Series

The LTA34BT series telescopic are small, aluminum alloy, three-beam ball bearing rails. In addition to other outstanding features it has an integral latching system which locks the rails when fully extended and retains it when fully closed. A firm initial pull is all that is necessary to open it, after which the rail travels freely. The rail is symmetrical.

The photograph shows the framework side in order to show the latch, which is pressed downwards to release.

The mechanical properties of both beams give the rail excellent load-carrying capabilities. Ball bearings, held in steel cages, ensure smooth and easy operation.

Dimensions in mm

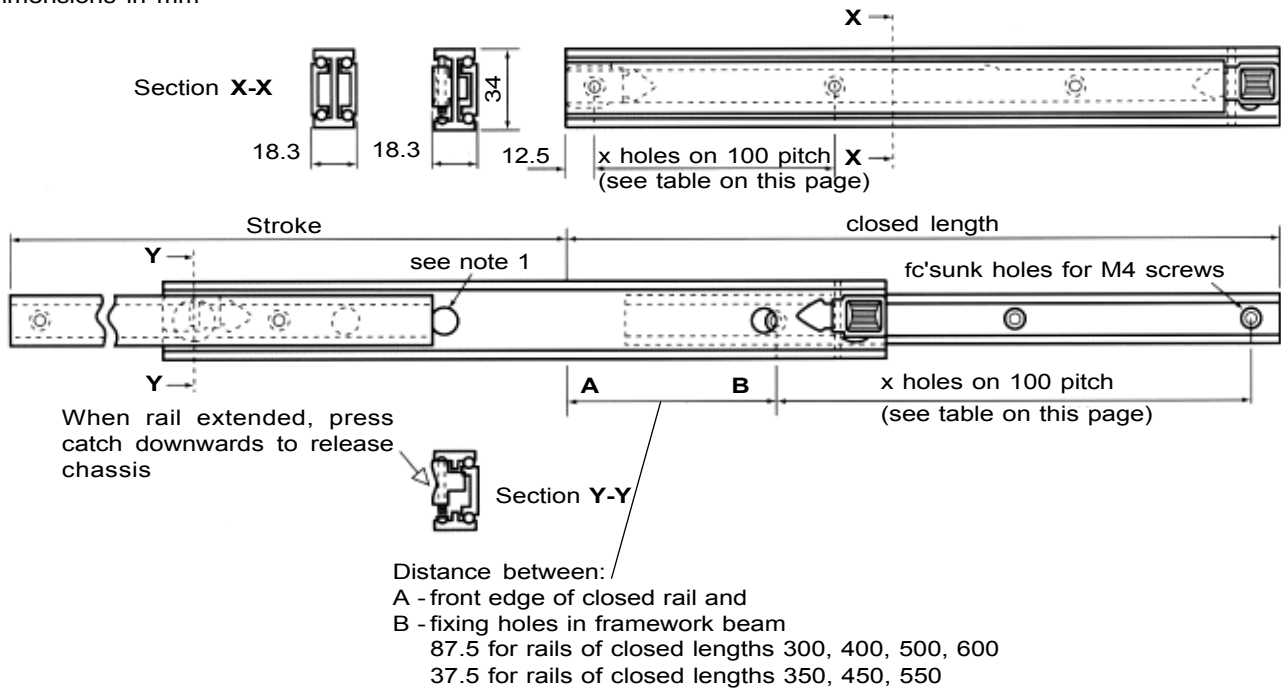

note 1: Ø10 mm holes in center beam allow easy access to fixing holes.

AVAILABILITY

Available in seven lengths as shown below. All incorporate 30 mm over-extension, thus effectively covering depths from around 300 mm to 630 mm.

Special requests can be discussed with our Technical Department.

STANDARD LENGTHS - LTA34BT Series

Closed length in mm

300 350 400 450 500 550 600

Stroke in mm

330 380 430 480 530 580 630

No. of holes in each beam (x)

3 4 4 5 5 6 6

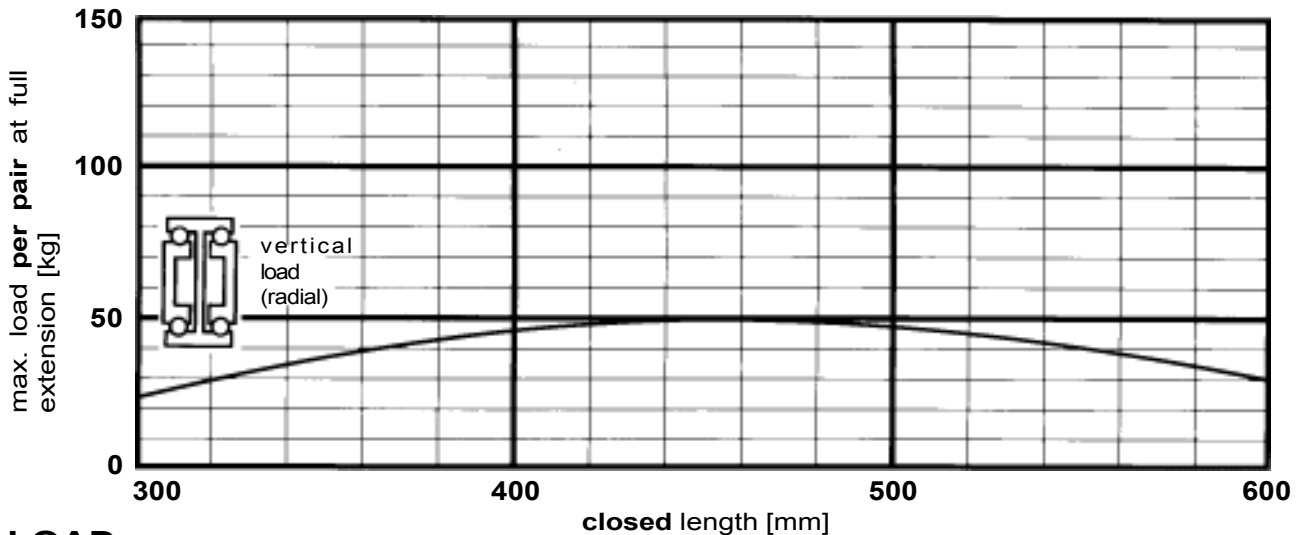

LOAD

This graph assumes a uniformly distributed load acting radially on a pair of rails which are rigidly attached throughout their length to the structure. The maximum load is governed by both the sag of the extended rail and the strength of the other rail components. The result is a rail whose load capacity increases with lengths up to 450 mm, after which the inverse ratio applies. The loads indicated are based on a maximum rail deflection of 8 mm and a maximum opening force of 7 kg.

SPECIFICATIONS

- All beams are made from anodized aluminum alloy.
- Ball bearings inside steel cages allow the sliding movement.
- Maximum operating temperature 70°C.
- Weight 2 kg/m per pair.

OPTIONS

- LTA34 are similar but do not incorporate the spring stop that allows the beam to be removed. See page 14.
- LTA34R are similar but incorporate a spring stop that allows the beam to be removed. See page 16.
- LTA51 are larger and offer complete telescopic movement (Stroke longer than the length of the closed rail). See pages 20-22-24.



ORDER CODES

LTA34BT - 300

