

NSA 8141 Female Series RFY--NSA

Menu

P/N X-Ref

Materials

Clearance/Torque

Staking Groove

Limits & Fits

Keyways

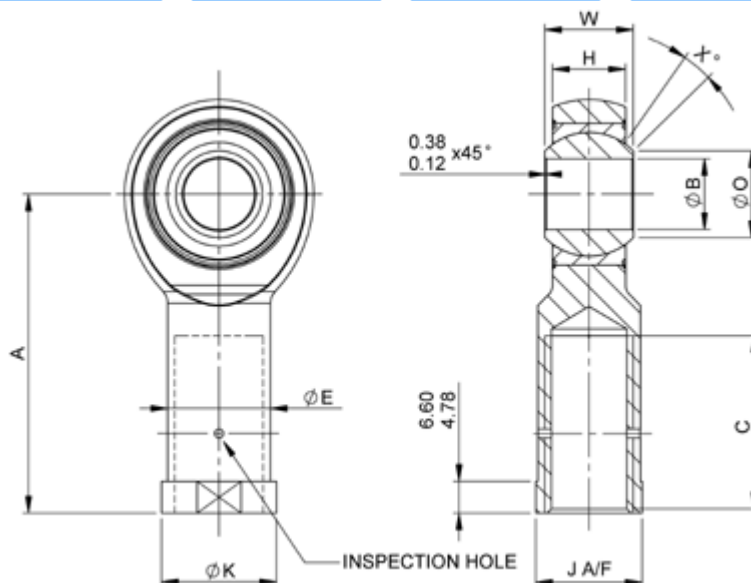

Bore code	B	D	W	H	O	A	C	K	E	J	X°	Ball dia nom	Threadsize UNJF-3A Mil-S-8879	Radial Static Limit Load daN	Weight g max
	+0 -0.0127	+0.254 -0.254	+0 -0.127	+0.127 -0.127	min	+0.254 -0.254	+1.524 -0.762	+0.254 -0.254	+0.381 -0.381	+0.254 -0.254	min				
03	4.826	20.472	11.100	8.560	7.66	34.925	19.050	12.700	10.719	11.100	15	13.487	.3125-24	2735	27
04	6.350	20.472	11.100	8.560	7.66	37.312	19.050	12.700	10.719	11.100	15	13.487	.3125-24	3353	27
05	7.938	22.860	11.100	8.306	10.18	34.925	19.050	12.700	10.719	11.100	14	15.080	.3125-24	3536	31
06	9.525	26.035	12.700	10.566	11.96	41.275	23.779	15.875	14.402	14.783	8	17.463	.3750-24	5366	49
07	11.113	29.210	14.275	11.481	13.77	46.024	26.975	17.449	15.494	15.875	10	19.837	.4375-20	6227	81
08	12.700	33.960	15.875	13.081	15.55	53.975	28.575	20.624	18.669	19.050	9	22.225	.5000-20	10408	127
10	15.875	38.735	19.050	14.656	19.09	66.675	38.100	25.400	21.844	22.225	12	26.975	.6250-18	11609	190
12	19.050	45.085	22.225	16.256	22.67	73.025	41.148	26.924	25.019	25.400	13	31.750	.7500-16	15346	231
14	22.225	51.435	22.225	19.431	26.94	85.725	47.625	30.150	28.194	28.575	6	34.925	.8750-14	17081	426
16	25.400	70.485	34.925	25.781	32.37	104.770	53.975	33.325	31.369	31.750	12	47.625	1.2500-12	40968	612

Dimensions in millimetres

Note: These rod ends conform to the NSA specification, but are not approved.



Head Office

UK

Germany

Contact Details

France

Italy

Singapore

USA