

NSA 8144 Male Series High Angle RMA Y--NSA

Menu

P/N X-Ref

Materials

Clearance/Torque

Staking Groove

Limits & Fits

Keyways

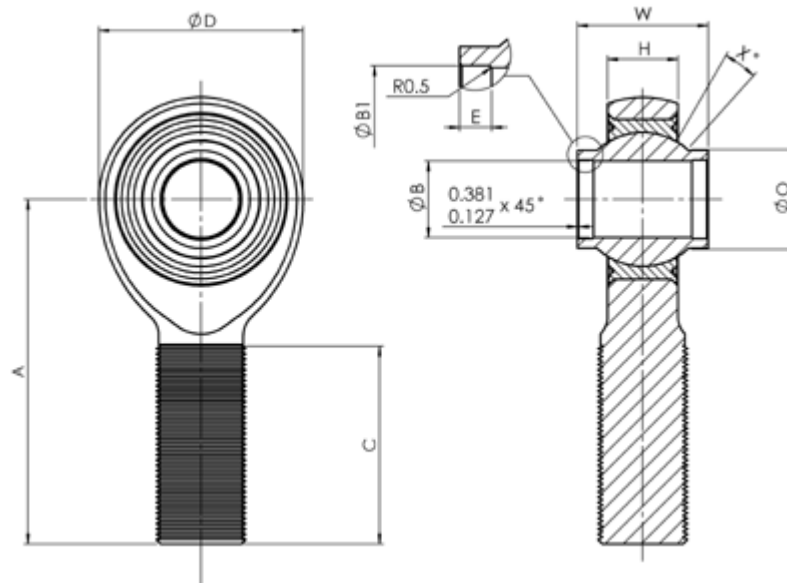

Bore code	B	D	W	H	O	A	C	X°	Ball dia nom	Thread size UNJF-3A Mil-S-8879	Radial Static Limit Load daN	E	B1	Weight g max
	+ 0 -0.013	+ 0.9 - 0.3	+ 0 - 0.13	+ 0.13 - 0.13	min	+ 0.25 - 0.25	+ 1.5 - 0.8	min				+ 0.5 - 0.1	+ 0.1 - 0.3	
03	4.826	19.050	12.700	5.588	8.00	38.100	25.400	15	11.100	.3125-24	1155	2.0	5.40	27.2
04	6.350	25.400	15.062	6.731	9.81	49.225	31.750	24	15.062	.3750-24	1417	2.0	6.90	49.8
05	7.938	28.575	20.650	9.017	12.90	53.975	34.925	23	19.837	.4375-20	2355	3.0	8.50	72.5
06	9.525	28.575	20.650	9.017	12.90	53.975	34.925	22	19.837	.4375-20	2355	3.0	10.10	72.5
07	11.113	33.325	22.225	9.017	15.60	61.925	38.100	22	22.225	.5000-20	3511	2.5	11.70	113.4
08	12.700	38.100	23.799	10.439	18.44	66.675	41.275	20	25.400	.6250-18	4978	3.5	13.30	181.4
10	15.875	44.450	30.480	14.656	21.64	73.025	44.450	20	31.750	.7500-16	5747	3.0	16.50	285.7
12	19.050	50.800	32.512	16.002	24.34	85.725	47.625	19	34.925	.8750-14	9557	4.0	19.60	408.2
14	22.225	55.880	35.560	16.129	28.36	95.250	50.800	19	38.887	.8750-14	10000	4.0	22.80	494.4
16	25.400	65.850	47.625	21.463	32.06	104.775	53.975	21	47.625	1.2500-12	15904	4.0	26.00	952.5
20	31.750	79.375	47.625	25.781	38.58	127.000	73.025	21	57.150	1.2500-12	28126	4.0	32.30	1292.7

Dimensions in millimetres

Note: These rod ends conform to the NSA specification, but are not approved.



Head Office

UK

Germany

Contact Details

France

Italy

Singapore

USA