

Who we are,
what we do.

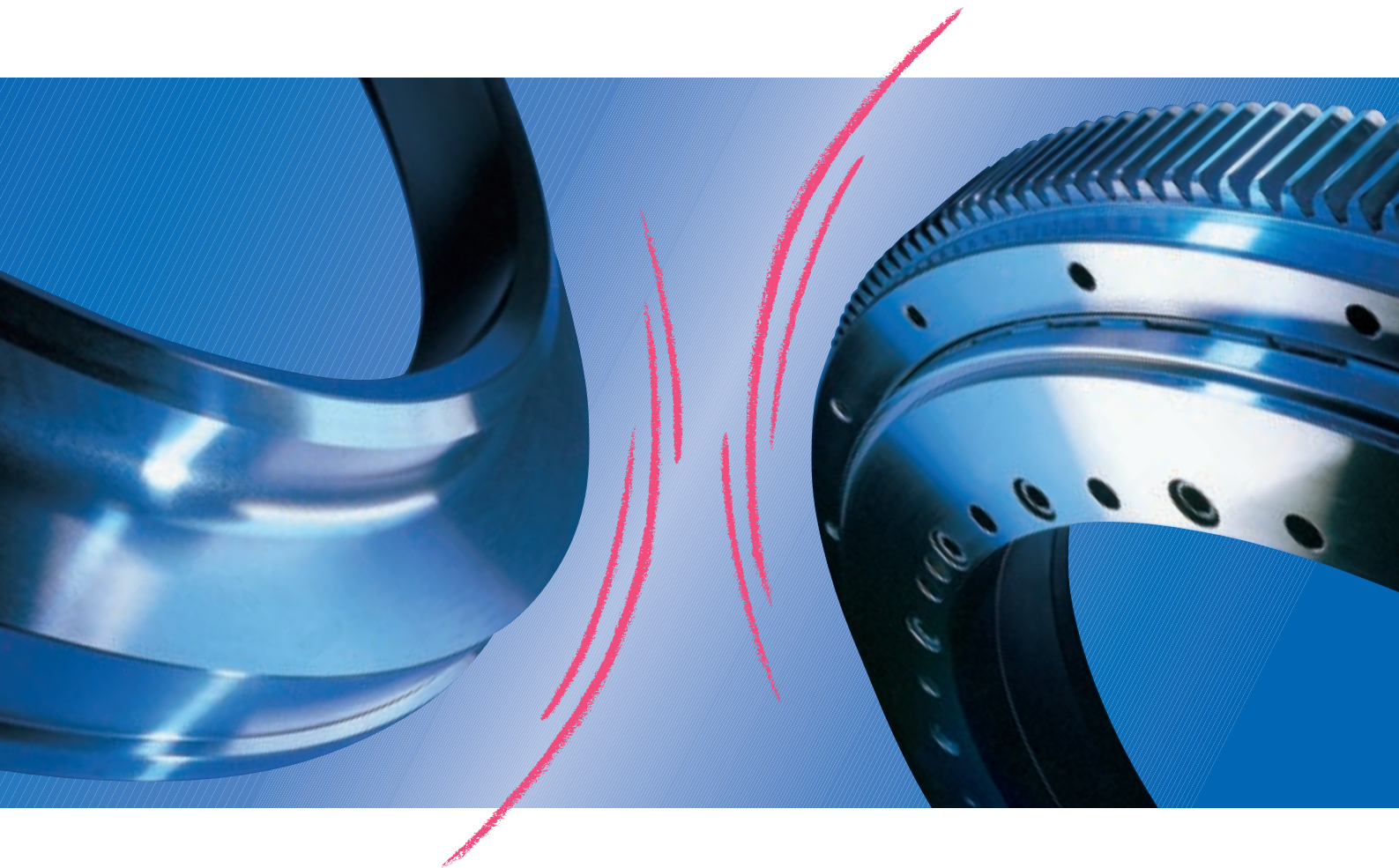

A ThyssenKrupp
Technologies
company

Rothe Erde



ThyssenKrupp

Rothe Erde® slewing bearings and rings. International competence.



Turning ideas into market orientated innovative products combined with a genuine commitment to our customers has been our maxim for over a hundred years. Our success is proof that we are on the right track with our production of bearings and rings in globally renowned high quality.

Planning, development and design are all part of an on-going dialogue with our customers. Once a customer has contacted us with his specific application and constructional needs, we begin searching for the optimum solution. We believe that our customers are entitled to get the best quality and every possible assistance from us.

Rothe Erde bearings and rings. All over the world.

Well thought out Rothe Erde production concepts stand behind a wide spectrum of ball and roller bearing slewing rings, turntables as well as seamless rolled steel and non-ferrous metal rings. They have helped us to secure a strong foothold in the international market place. Our production facilities, distribution and

sales agencies in major industrialised countries allow us to quickly respond to customer requests as varied as these may be. It goes without saying that our experts are at our customers' disposal for assistance and advice before as well as after delivery of our product.

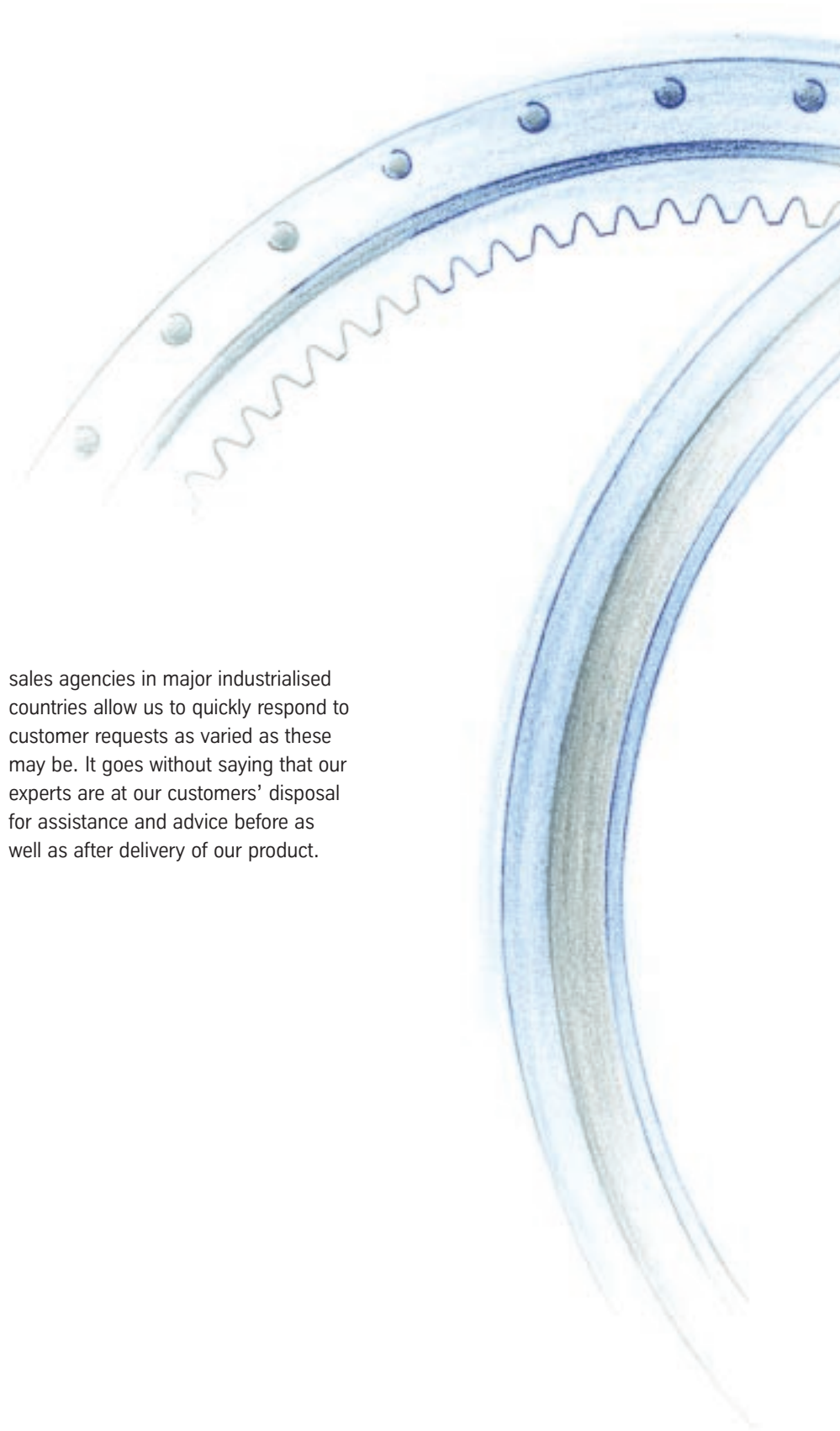



Our domestic as well as our international production sites are committed to offering our customers nothing but the highest quality level. All our activities from application engineering to design and production including comprehensive customer service are based on the DIN/ISO 9001/2000 standard of quality.

Looking ahead. Design and development.

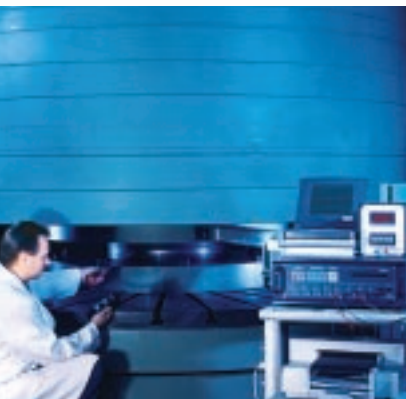
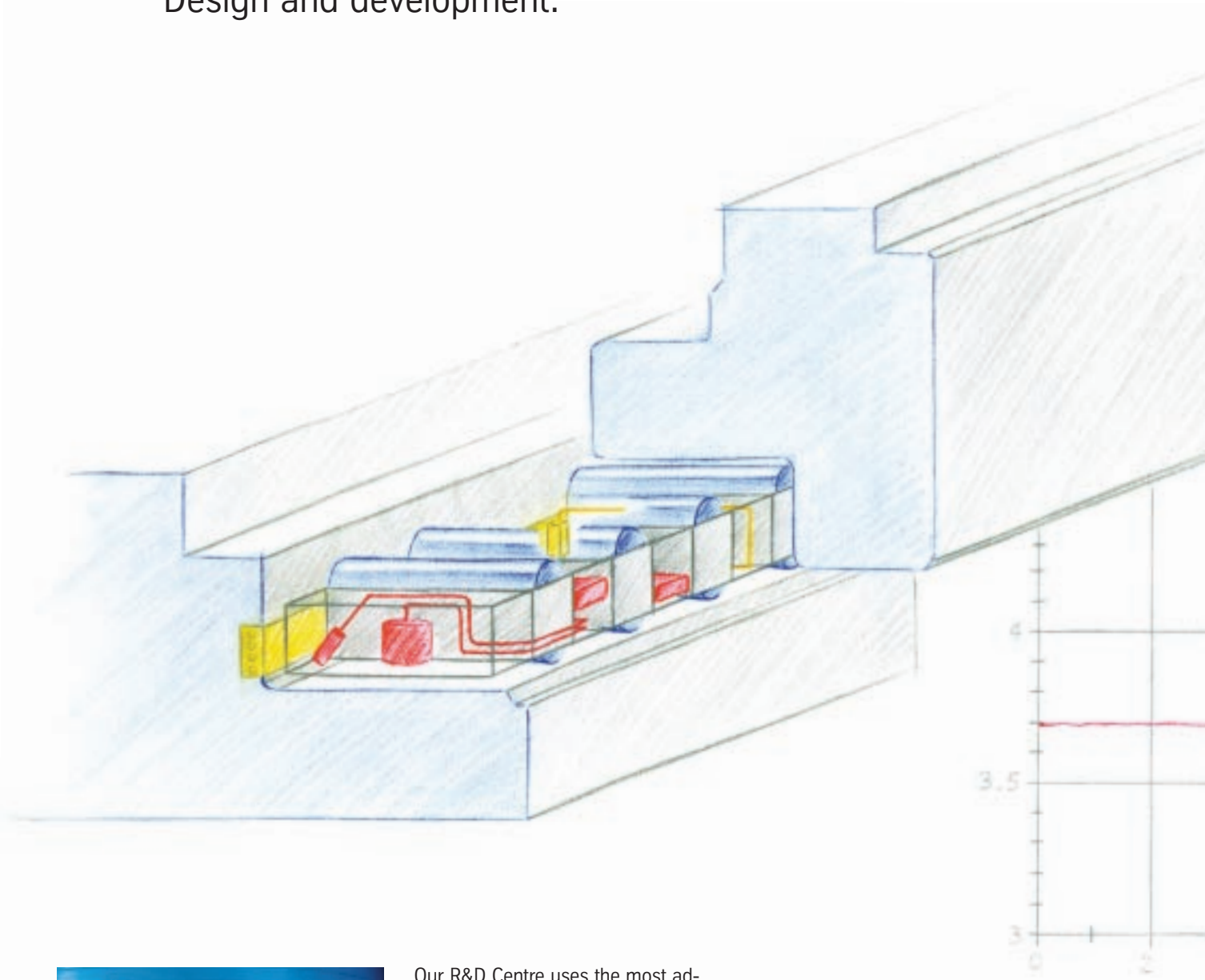

Our R&D Centre uses the most advanced technologies for testing our bearing designs by simulating the toughest of service conditions. We believe that development should be an on-going process paving the way for future-orientated practical solutions. Knowledge and experience combined with new ideas to create exactly the products our customers need.

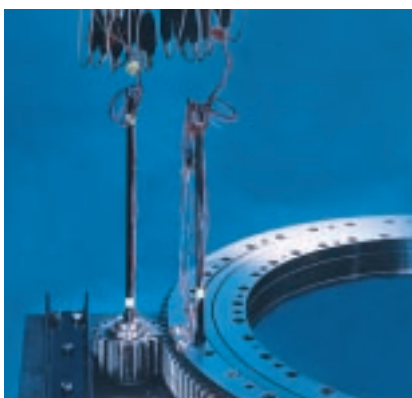

New bearing monitoring systems are only one example for our successful R&D activities. The Rothe Erde Eddy Current Condition Monitoring System assures operational safety by continuously checking the condition of a bearing without requiring time and cost consuming inspections.



Rothe Erde rings.

The production programme with a profile.

The production of seamless rings on our advanced ring rolling mills is one of our strong points. Our expertise in this field is founded on steel forming experience gathered over more than a hundred years.

Constant advances in development enable us to help solve even the most difficult problems. One of the major foremost priorities of production is optimum material usage to minimise machining allowances.

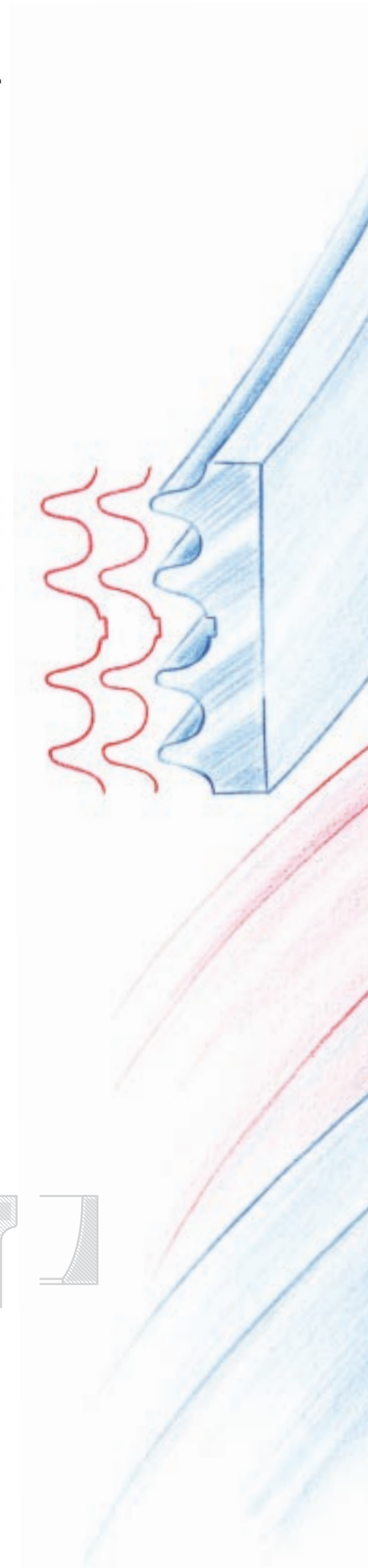

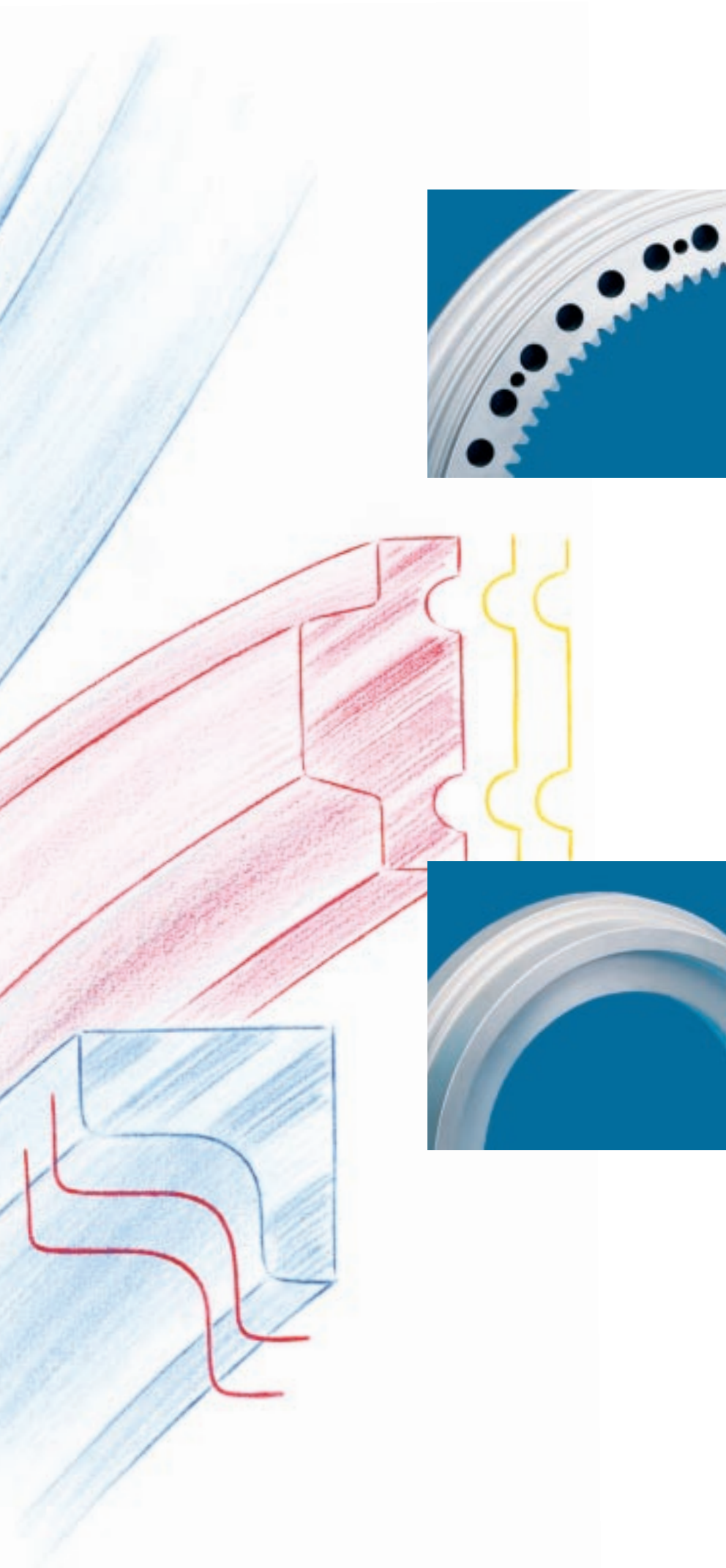

Interlinked CAD and DNC systems assist in the optimisation of ring dimensions for the manifold applications.

Rothe Erde rings are important structural and connection elements used in large gears, turbines, generators, transformers, hydraulic motors, large valves, animal feed presses, offshore technology, wind power plants, and in aviation and space flight systems.

High-tech precision manufacture.

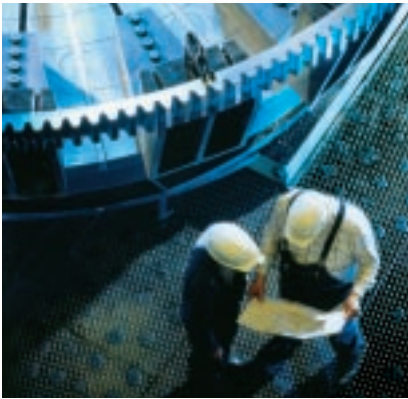
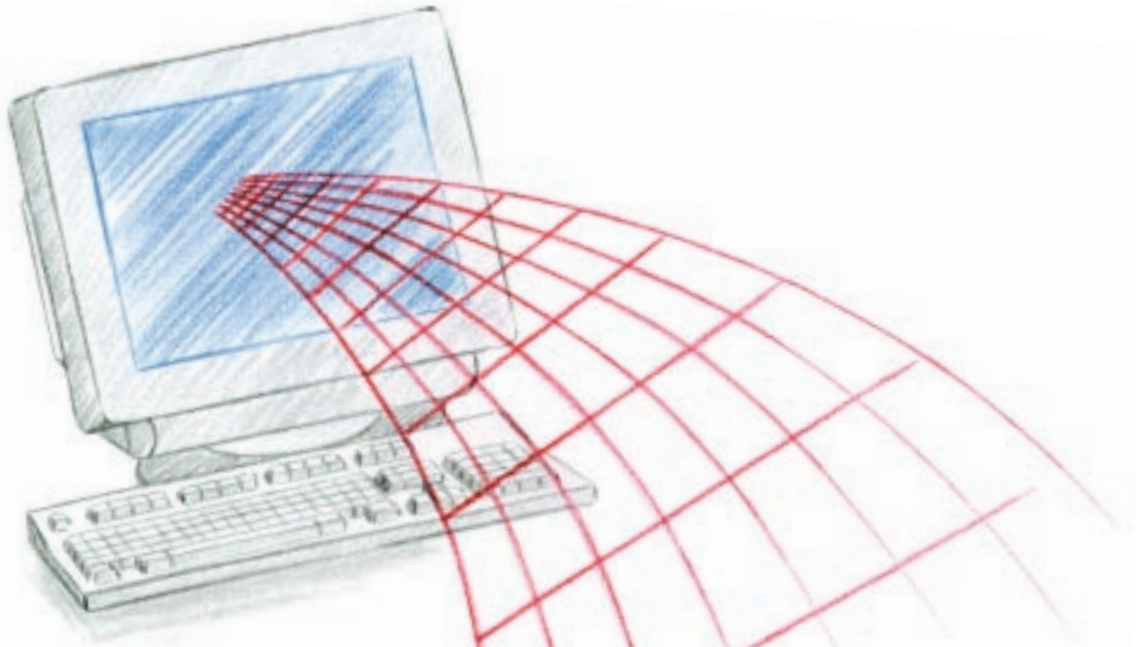

All machining steps on the road from the blank to the ready to install bearing are precisely documented in the form of working plans and also available as data controlled production processes.

During the run-up to production, quality has already been brought into all relevant parameters.

High-tech installations then assure perfect implementation and strict adherence to the high quality our customers have come to expect from us.



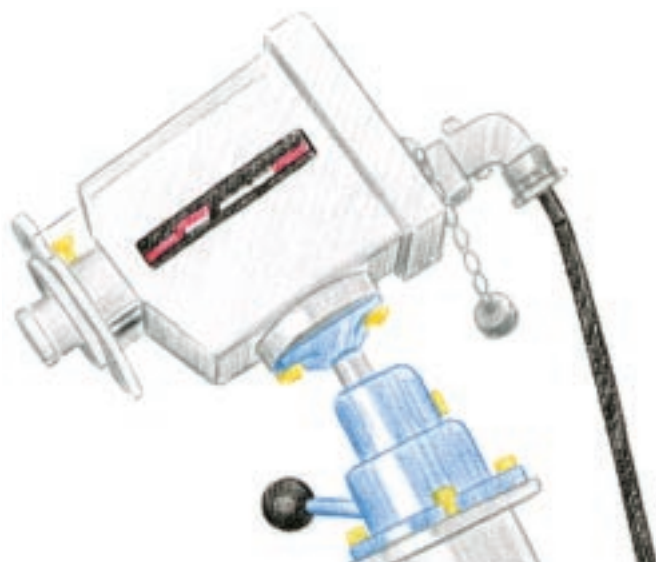

All processes up to the documented final acceptance are monitored by electronic control systems assuring sustained high quality of all turning, gear cutting, hardening, drilling and grinding operations.

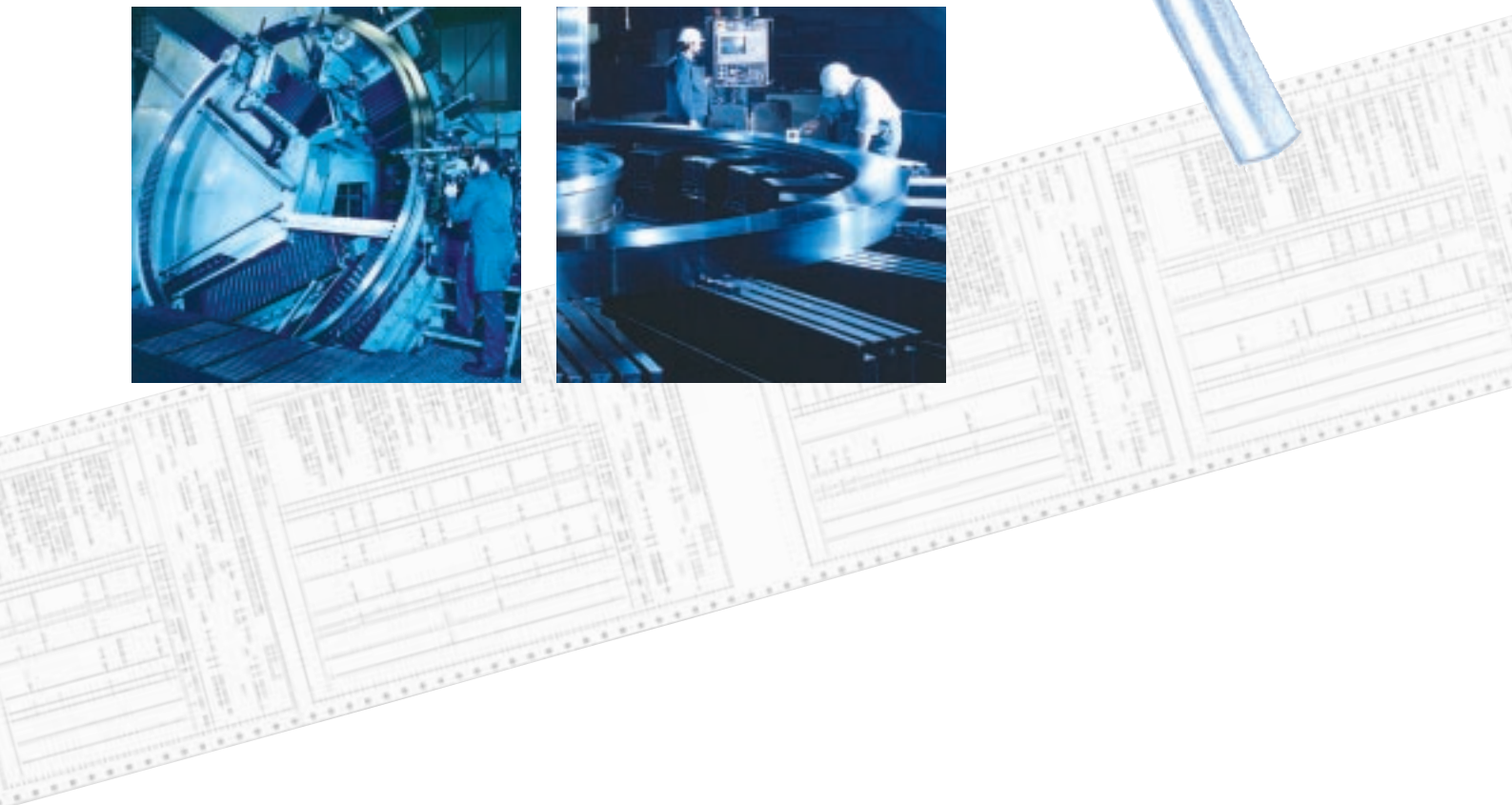

We make ideas move.



Rothe Erde enjoys an excellent international reputation and stands world-wide for reliable high quality large diameter bearings.

We offer a comprehensive bearing programme for a wide variety of applications. Continuous adaptation to new requirement criteria for bearings and materials have led to a number of different basic designs:

- Ball bearing slewing rings in single- or multi-row configurations, with or without gearings,
- Roller bearing slewing rings for extremely high loads from axial and radial forces as well as resultant tilting moments,
- Wire-race bearings for special applications, including aluminium designs,
- Precision bearings for particularly stringent requirements on running accuracy,
- Turntables for a variety of vehicles.

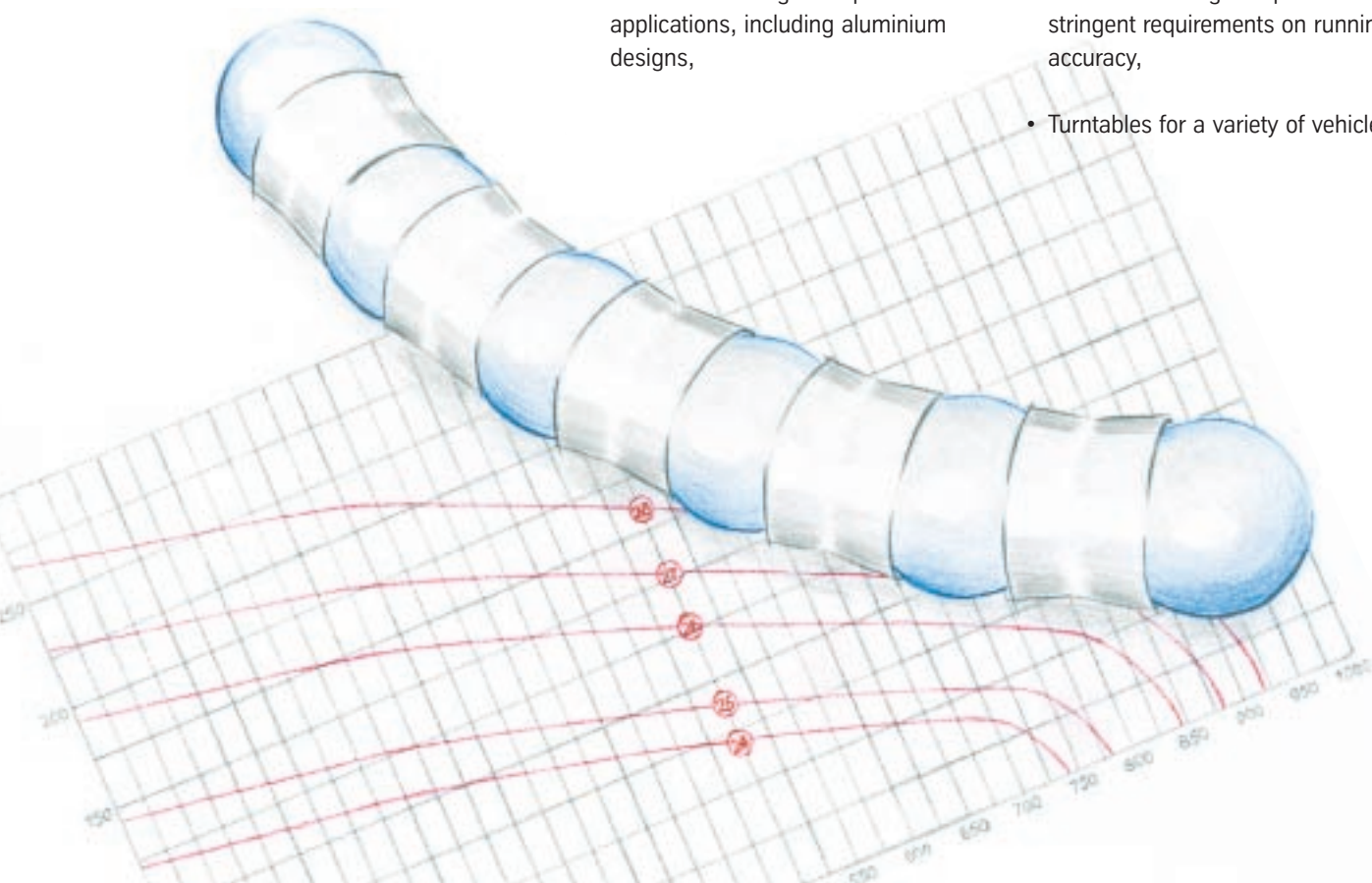
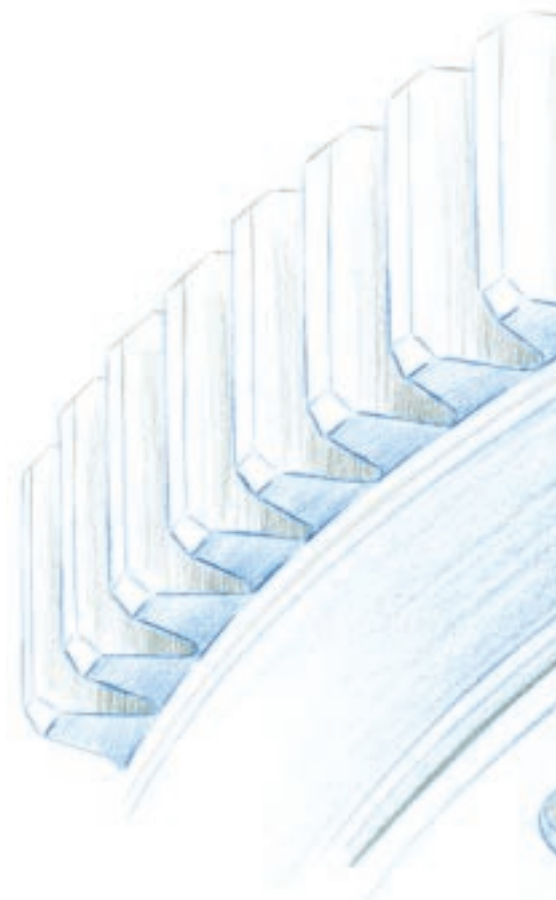

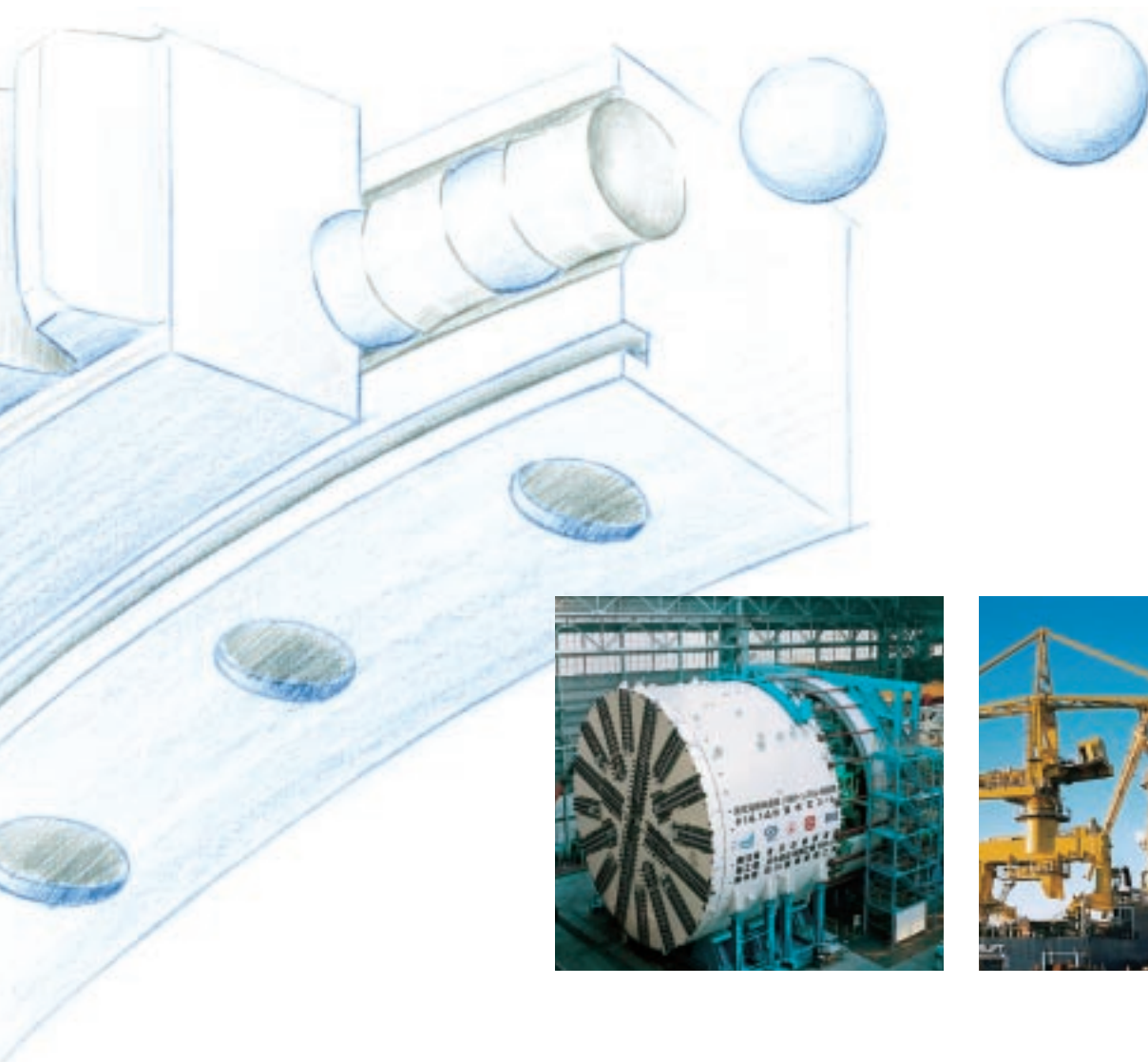

Rothe Erde bearings are proving themselves time and time again as structural elements in general machine construction, mechanical handling and extraction equipment, in dockside, deck and construction cranes, as well as in earth moving machinery. In addition, our

bearings have gained a foothold in many new technologies including solar and wind power plants, tunnelling machines, offshore technology, communication and aerospace systems and installations.

Rothe Erde slewing bearings. Outstanding in extreme situations.

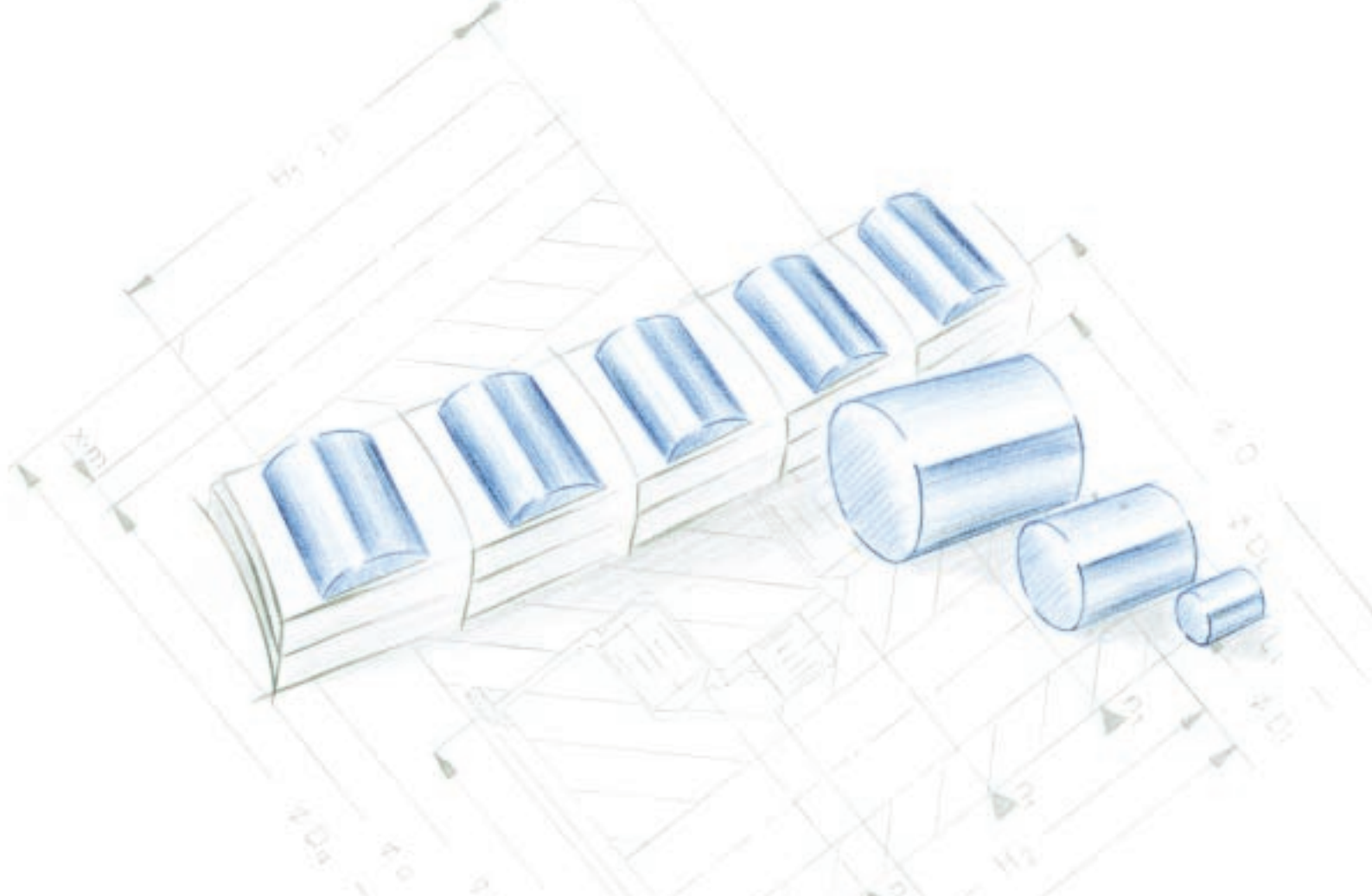



Offshore technology, wind energy harnessing and many other applications demand maximum capacity and structural safety from a Rothe Erde bearing. It is here – under physically extreme conditions – that our products are setting the standards for reliability and economy.

Drilling and extraction platforms need the best and safest equipment available. Strict conformance with specifications is controlled by supervisory bodies and classification agencies.

MaQus. The Rothe Erde integrated management system.

The integrated management system put in place at Rothe Erde includes the following elements:

- Quality assurance system to DIN/ISO 9001/2000;
- Environmental protection to DIN/ISO 14001 and
- Occupational safety to OHSAS 18001.



Rothe Erde is aware of its responsibility vis-à-vis its staff, its business partners, and the population as a whole.

Our declared goal is to promote and intensify customer relations, to offer products of the highest possible quality, and to minimise detrimental effects on people, environment, and equipment. The protection of resources as well as continuous process improvement are important elements of our company policy.

Our products are designed and manufactured to in-house standards and specific customer requirements based on tried and proven calculation methods, design guidelines and production processes.

Quality assurance, environmental protection and safety are the factors which have brought Rothe Erde economical success.

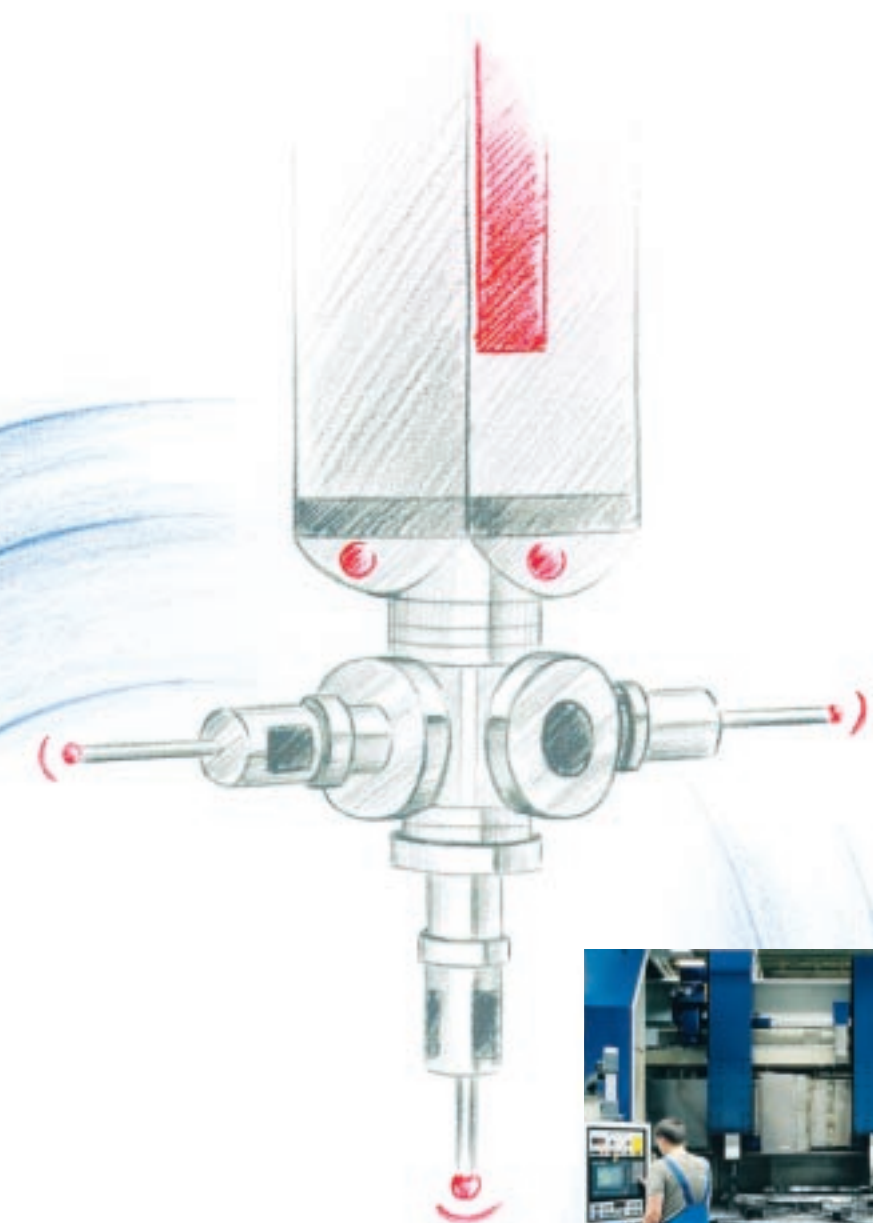

The foundation of our management system is the documentation of all procedures and process flows in the form of procedural and work instructions taking into account legal requirements, regulations, guidelines, specifications and agreements.



We believe that only highly motivated employees can achieve effective quality assurance, environmental protection, occupational and equipment safety. Regular exchange of experience as well as basic and on-going training promote the awareness of our employees at all levels allowing them to act competently and responsibly.

Rothe Erde.

Where you can find us.



Great Britain

Roballo Engineering Co. Ltd.
Mill Hill
North West Industrial Estate
GB-Peterlee, Co. Durham SR8 2HR



France

Roballo France S.à r.l.
30, Boulevard Bellerive
F-92566 Rueil Malmaison CEDEX



U.S.A.

Rotek Incorporated
1400 South Chillicothe Rd.
USA-Aurora, Ohio 44202



Brazil

Robrasa
Rolamentos Especiais
Rothe Erde Ltda.
Rua Lidia Blank, No. 48
BRA-CEP 09913-010, Diadema,
São Paulo



Spain

Roteisa
Rothe Erde Ibérica S.A.
Carretera Castellón, km. 7
Polígono Industrial „La Cartuja“
E-50720 La Cartuja Baja (Zaragoza)

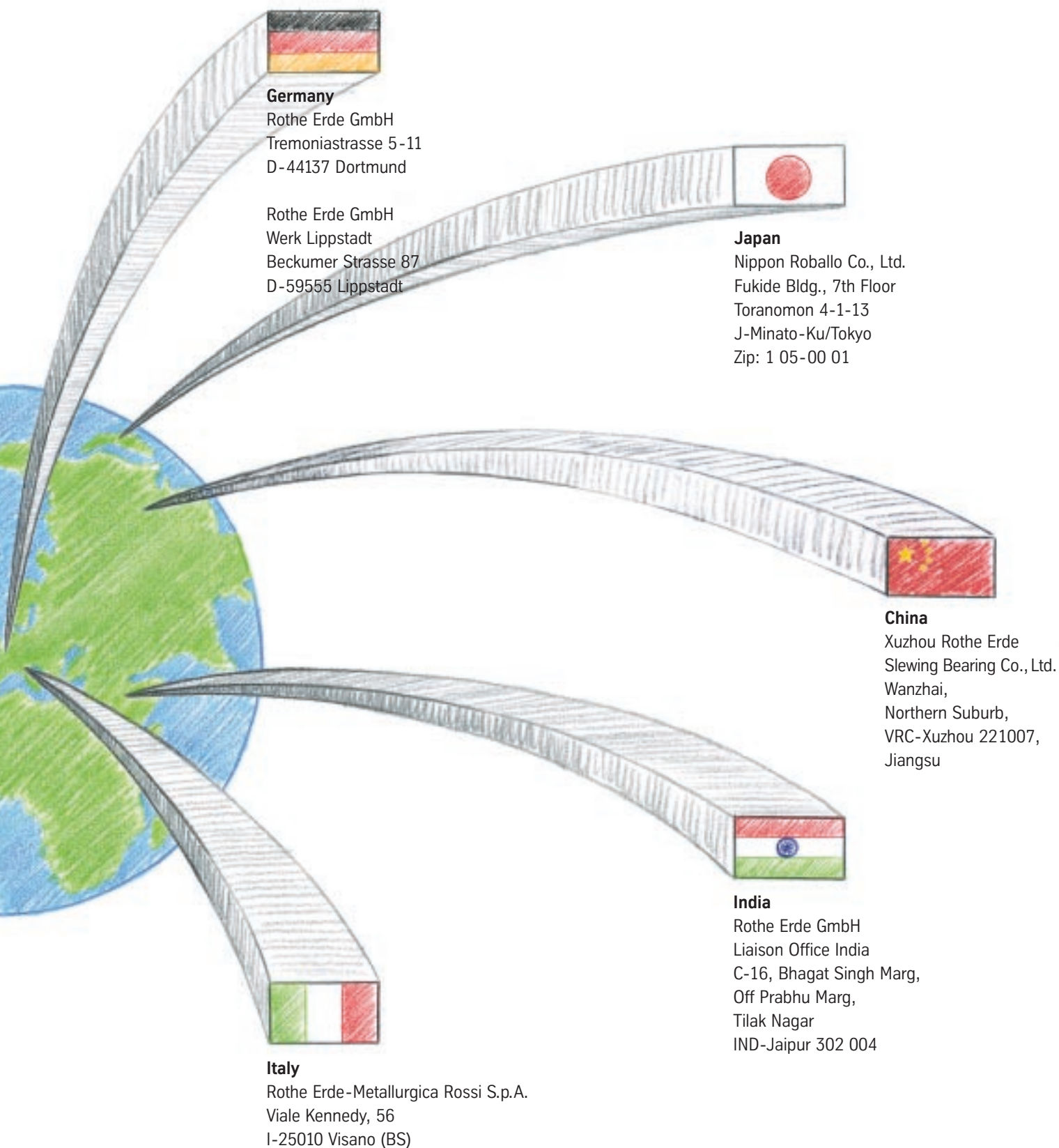



Rothe Erde GmbH

Tremoniastrasse 5-11 · D-44137 Dortmund

Phone: +49 (2 31) 1 86 -0

Fax: +49 (2 31) 1 86 -25 00

E-mail: rotheerde@tk-re.thyssenkrupp.com

Internet: www.rotheerde.com

