

vibro-meter  
certified by

# GSI 122 & 130

## Galvanic Separation Units Types GSI 122 & GSI 130

### CHARACTERISTICS

- Vibration monitoring
- Long distance signal transmission
- CENELEC / PTB approved
- CSA approved

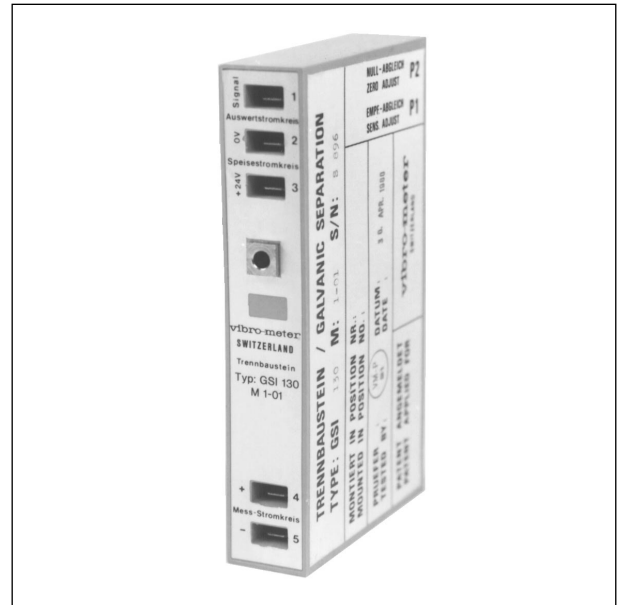

### DESCRIPTION

The GSI 122/130 galvanic separation unit is used for supplying transducers and conditioners and for reading off signals given by them.

It is used in 2-wire transmission systems. In a more general application it serves for supplying any electronic system with a consumption of less than 20 mA.

This unit outputs a voltage signal proportional to the current consumed by the conditioner. This voltage signal is directly available for analysis of the conditioner signal.

The GSI 122/130 module avoids any problems due to voltage differences between the measuring point and the signal processing (e.g. earth loops).

The GSI 122 Version 20x conforms to the CENELEC and CSA standards concerning the powering of transducers and conditioners mounted in explosive areas.

The use of the GSI 122/130 in an installation avoids the need to mount Zener barriers, which generate additional voltages drops and limit the length of the transmission line and the dynamic range of the system.

### Block Diagram :

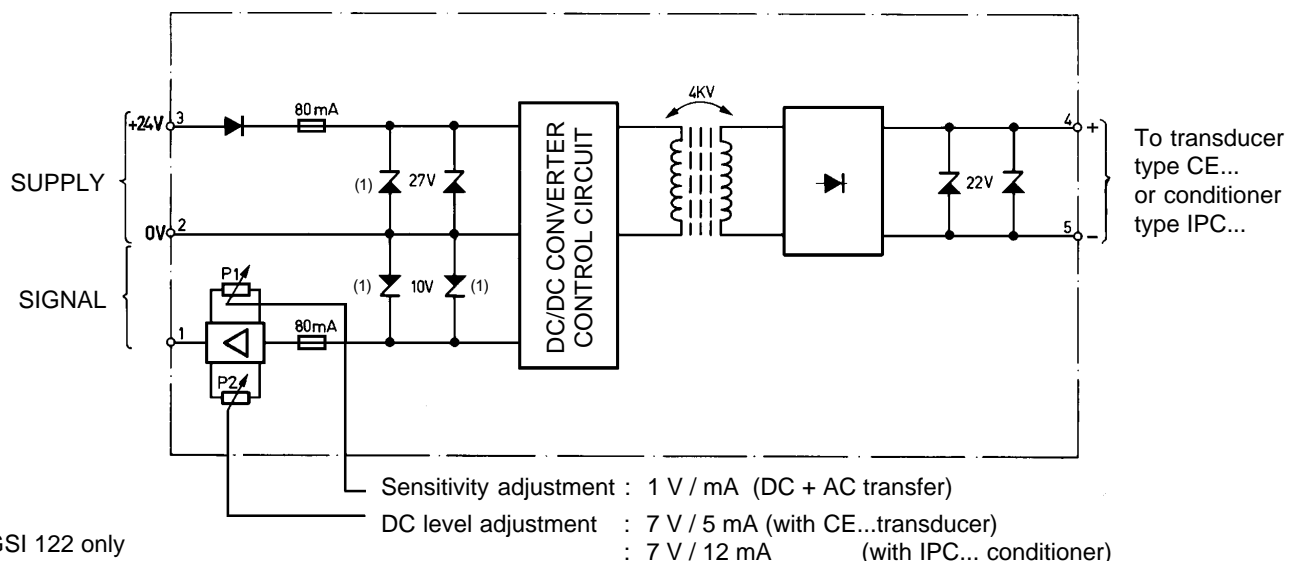

## SPECIFICATIONS

## GSI 122 & 130

**Supply voltage (to GSI)** : +24 V  $\pm$ 5% (e.g. from UVC... processor)

**Ripple** (100 Hz) : 100 mV pp max.

**Consumption:**

- No load : Approx. 20 mA
- 20 mA load : Approx. 60 mA
- Short-circuit : Max. 120 mA

**Output voltage (to conditioner):**

- No load : 18 V  $\pm$ 1 V
- 20 mA : 16 V  $\pm$ 1 V

**Short-circuit current** : 60 mA

**Pass-band** : DC to 10 kHz  $\pm$ 0.5%, -1 dB at 20 kHz

**Transfer function** : 1 V/mA factory set (potentiometer P1)

**Temperature drift** : <200 ppm/ $^{\circ}$ C

**Linearity** :  $\pm$ 0.5% over dynamic measuring range

**DC signal component (to UVC)** : Adjustable by potentiometer P2  
Umin. = +2 V  
Umax. = power supply (+24 V  $\pm$ 5%) - 2.5 V

**Noise:**

- Max. residual on signal : 12 mVpp at 5 mA DC  
25 mVpp at 12 mA DC

**Galvanic separation between the input and output circuit** :  $\geq$ 4 kV RMS

**Electrical connections** : 5 lugs, type AMP-Faston 6.3

**Temperature range**

- Operation : 0 $^{\circ}$ C to +55 $^{\circ}$ C
- Storage : -20 $^{\circ}$ C to +70 $^{\circ}$ C

**Mechanical construction** : Printed circuit board, potted, mounted in a plastic casing.

- Dimensions : 130 x 74.5 x 23 mm

**Mounting**

: The unit is fixed by a single M4 screw and positioning lug ( $\varnothing$ 4.5 mm). Refer to data sheet "Mounting accessories for GSI/GSV units".

**Dimensions:**

- Width : 23.0 mm
- Height : 130.0 mm
- Depth : 74.5 mm

**Weight** : Approx. 430 g

**CENELEC/PTB certificate** : Ex-80/2184, type EEx ib II C

**CSA certificate** : LR 62075-1, type EEx ia, class I, groups A, B, C, D.

### Ordering Information :

To order please specify:

- Type, designation and ordering number

Type	Designation	Part Number (P/N)	Exi Certification
GSI 122	Galvanic Separation	244-122-000-20	CENELEC / PTB + CSA
GSI 130	Galvanic Separation	244-130-000-20	None

- DC level adjust. : 7 V  $\rightarrow$  5 mA for CE... transducer  
7 V  $\rightarrow$  12 mA for CA.../CP... transducer + IPC... conditioner

If not specified, the DC level adjust is 7 V  $\rightarrow$  5 mA.



Due to the continual development of our products we reserve the right to modify the specifications without forewarning.

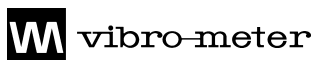

### Head Office

**Vibro-Meter SA**, Rte de Moncor 4,  
P.O. Box 1071, CH-1701 Fribourg, Switzerland  
Phone : +41 26-407 11 11  
Fax Industrial & Marine : +41 26-407 13 01  
Fax Aerospace : +41 26-402 36 62  
Fax Instrumentation : +41 26-407 13 75  
E-mail : vmsa@vibro-meter.ch  
Internet : www.vibro-meter.com  
www.meggitt.com

### Sales Offices in :

- ◆ Germany ◆ France
- ◆ USA ◆ Canada
- ◆ Singapore ◆ United Kingdom
- ◆ Russia ◆ Ukraine

Agents in over 30 countries

Vibro-Meter is a member of the  
Meggitt Aerospace Systems Division