



Accurate mounting of bearings, propellers and gears has never been quicker . . .

Save 50% on mounting time with SKF Hydraulic Techniques

Mounting and dismounting bearings or other industrial components, especially larger ones, requires large forces. Applying these forces manually not only demands a considerable effort, but is also time consuming and can give inaccurate and hazardous results.

SKF Hydraulic Techniques help you apply these large forces with the minimum of effort and save you up to 50% on mounting time.

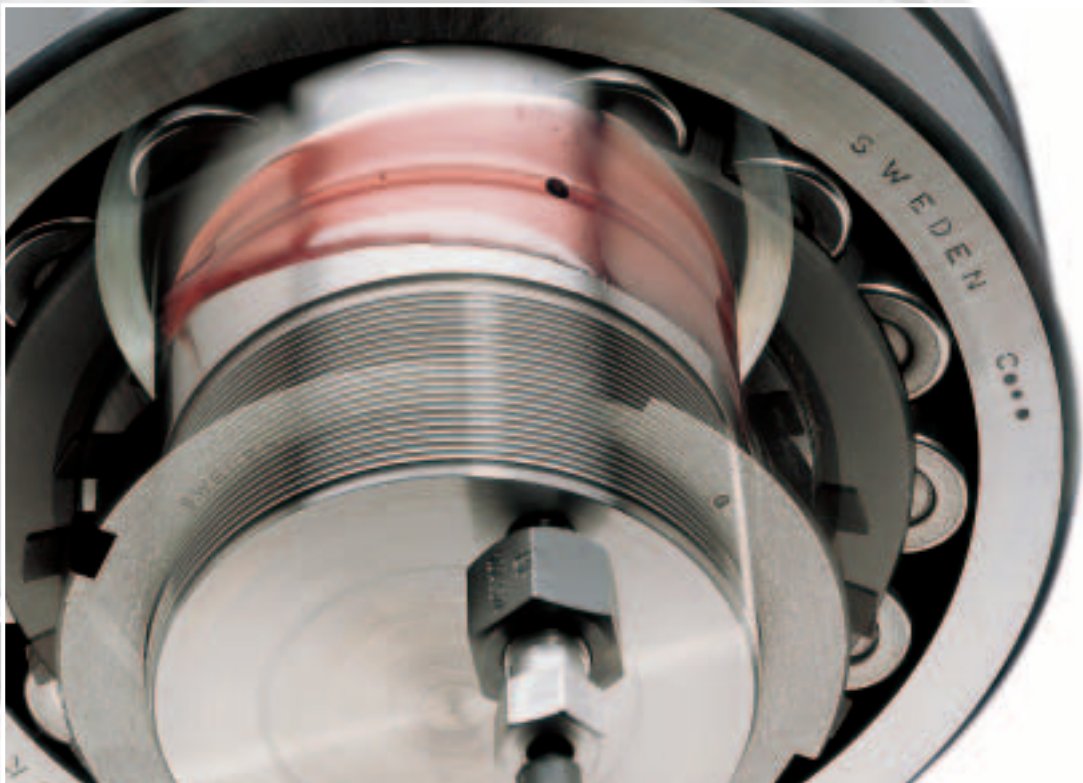

SKF pioneered hydraulic techniques

SKF pioneered the use of hydraulic techniques for mounting and dismounting bearings and other industrial components. These techniques help simplify bearing arrangements, reducing the time and cost of maintenance. In addition, hydraulic techniques can also be used for non-bearing applications; this is especially true in the heavy industrial segments.

Save money:

- Greatly minimise the risk of damaging components and shafts
- Quicker mounting and dismounting reduces machine downtime

Safe:

- Less manual effort combined with more control help ensure operator and machinery safety

Easy:

- Reduce manual effort; hydraulics do the hard work
- SKF calculation programs provide you with all information you need - no special training is required

Reliable:

- More controllable than other available techniques, allowing precision, accuracy and repeatability to be maintained

The SKF Oil Injection Method

Invented by SKF in the 1940's and continuously developed since, the SKF Oil Injection Method allows bearings with an interference fit, also known as a shrink fit, to be fitted and removed in a safe, controllable and rapid manner. The SKF Oil Injection Method separates the mating surfaces by a thin film of oil injected under high pressure, thereby virtually eliminating the friction between them.

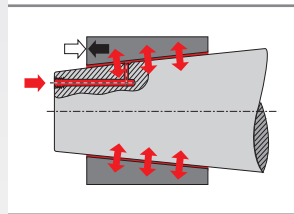

Mounting and dismounting, directly on a tapered shaft

Tapered seatings:

Oil injection can be used for both mounting and dismounting bearings fitted on tapered shafts, adapter or withdrawal sleeves.

- Reduces the friction between the bearing and the tapered seating
- Reduces the push-up force when mounting
- Rapid and safe dismounting; oil injection overcomes the interference fit

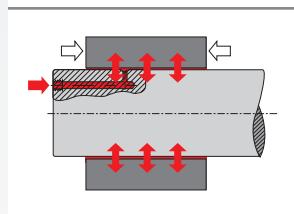

Dismounting, cylindrical shaft

Cylindrical shafts

Oil injection can be used to dismount bearings fitted on cylindrical shafts.

- Virtually eliminates the friction between bearing and shaft, allowing easy and quick dismounting
- Greatly reduces the required puller force by up to 90%
- Helps to minimise bearing and shaft damage

The SKF Drive-up Method

The use of feeler gauges requires a high degree of skill and experience to obtain repeatable and accurate results. The SKF Drive-up Method has been developed to simplify the mounting of bearings on tapered seatings. The correct fit is achieved by controlling the axial drive-up of the bearing from a predetermined position. The method incorporates the use of an SKF HMV..E hydraulic nut fitted with a dial indicator and a highly accurate digital pressure gauge mounted on an appropriate pump. The SKF Drive-up Method can be used for mounting bearings directly on solid or hollow shafts and on sleeves.

- The easiest method for mounting spherical roller and CARB® bearings
- Easier and more accurate than using feeler gauges, no special skills required
- Time savings of up to 50% compared to the feeler gauge method
- Helps to reduce bearing damage caused by driving-up the bearing too far onto its seating
- Easy to apply in situations where greater or less internal clearance reduction than standard is required
- Ideal for mounting bearings on vertical shafts



Hydraulic techniques for bearings

For medium and large size bearings, the force required to drive the bearing up onto a tapered seating can be quite considerable. To simplify the fitting and removal of bearings, SKF has developed a range of methods and tools, which considerably reduces the effort required. Using hydraulics helps to keep the manual effort to the minimum while maximum safety and controllability are achieved. These benefits have made the SKF hydraulic techniques the preferred bearing mounting and dismantling methods in many industries.

Mining

In the mining industry, ensuring safety is a top priority. The SKF Oil Injection Method is the preferred mounting technique as it is much safer than using heating equipment. Additionally, the method facilitates the mounting and dismantling of bearings and other components in a fast and easy manner.







Pulp & paper



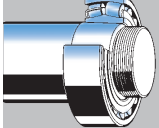

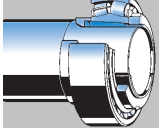
In the pulp and paper industry, the SKF hydraulic techniques offer the quickest and most accurate bearing mounting and dismantling solutions. Using the SKF Drive-up Method allows precise mounting of spherical roller and CARB® bearings, while reducing mounting time by up to 50%.

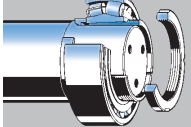

Application of hydraulic techniques for mounting and dismantling bearings

SKF hydraulic techniques have been developed to suit many different bearing applications. The table lists which technique is most suitable for mounting and dismantling different types of bearings. As the size of the bearing increases, it is important that provision for using the SKF Oil Injection Method is made. This means that the shafts must be designed and machined to include the required ducts and grooves. When mounting on sleeves, many of the larger size sleeves are available with the required ducts and grooves incorporated.

	Bearing arrangements		Mounting tools	
	Small bearings	Medium bearings	Drive-up Method	Oil Injection Method
Cylindrical seating  Cylindrical roller bearing types NU, NJ, NUP, all sizes				
Tapered seating 				
Adapter sleeve 				
Withdrawal sleeve 				

Key			
Hydraulic nut and pump 	Oil Injection Method 	Drive-up Method 	Bearing puller 

Hydraulic techniques for non-bearing applications

Interference fits have long been recognised for their reliability in transmitting large torsional loads. They often offer the only solution when connecting hubs to shafts with intermittent or fluctuating loads. However in practice, interference fits can be difficult to achieve as the component to be fitted usually has to be heated. If tapered seatings are used with a component with a corresponding taper, then high-pressure oil can be used to separate the surfaces. To simplify the application of interference fits, SKF developed the Oil Injection Method:

- Mounted component requires no heating - oil pressure does it all
- Maximum control during mounting with minimum effort, achieving precise interference fits
- Rapidly achieves the interference fit required saving time and money in operation
- Smaller shafts are possible, reducing material expenditure
- Eliminates the use of keys and keyways
- Helps reduce the risk of component failure due to fretting fatigue - reliable in practice
- Rapid dismounting, even for heavy interference fits - simple tools do the job fast
- Helps to minimise risk of shaft damage during mounting and dismounting, reducing the risk of costly component damage
- Pioneered by SKF over sixty years ago - a well-proven technique for many applications

Dismounting tools

Hydraulic nut

Oil Injection Method

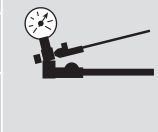
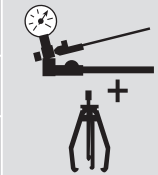

Marine applications

The SKF Oil Injection Method is particularly strong in the marine industry. For mounting large propellers on main propulsion shafts, the method is probably the most widely used technique for merchant vessels. It is recognised by all the main classification societies as a valid and reliable method of fitting propellers to shafts. Other Marine applications include the well-known SKF OK Coupling, which enables plain cylindrical shafts without flanges to be joined together. By eliminating the need for flanges, the shaft line can be made shorter, thus gaining valuable cargo space.

Gearbox applications

Ashore, the use of the SKF Oil Injection Method can be found in many industries. Large customised gearboxes can be constructed with the gears or gearwheels fitted using oil injection. In these applications, oil injection can achieve the high interference fits, which are required in a controllable, accurate and safe manner.

Railway applications

The rail transport industry has embraced SKF hydraulic techniques for trains and trams. Railway wheels can be mounted and dismounted with a fraction of the force previously required, if oil injection is used between the wheel and the axle. In addition the risk of damaging the axle when removing the wheel is greatly reduced. Today the use of the SKF Oil Injection Method for railway transmissions to fit the gearwheel is a well-established technique.



The tools

SKF has developed a comprehensive range of tools and equipment to put the hydraulic techniques into effect. A wide range of pumps and oil injectors developing pressures up to 400 MPa (58,000 psi) is readily available, as well as a complete range of accessories including pipes, pressure gauges and connection nipples.

HMV..E Nuts

Invented by SKF, HMV..E type Hydraulic Nuts facilitate the mounting and dismounting of medium and large size bearings with a tapered bore:

- Reduces time and effort compared to other methods
- Can be used directly on shafts, adapter and withdrawal sleeves
- Available with either metric or imperial threads or with a plain bore
- Specially designed to facilitate the SKF Drive-up Method

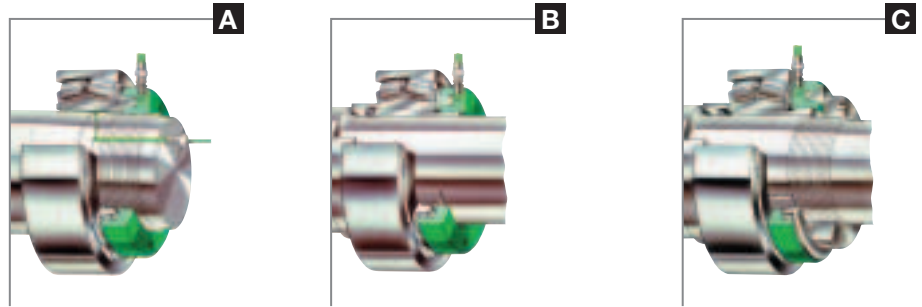

A HMV E nut for driving the bearing onto a tapered seating.
B HMV E nut for driving the bearing onto an adapter sleeve.
C HMV E nut and special stop nut for driving in a withdrawal sleeve.

Max. working pressure	Pump	Type	Max. working pressure	Pump	Type
30 MPa (4,350 psi)	THAP 030	Air-driven pump	300 MPa (43,500 psi)	THAP 300E 226400 729101 B TMJE 300 226270 226271	Air-driven oil injector
50 MPa (7,250 psi)	TMJL 50	Hand operated pump			Hand operated oil injector
70 MPa (10,000 psi)	TMJA 70E	Air-driven pump			Oil injection kit
100 MPa (14,500 psi)	729124 TMJL 100	Hand operated pump Hand operated pump	400 MPa (58,000 psi)	226400/400MPa 729101 E TMJE 400	Screw injector
150 MPa (21,750 psi)	THAP 150 728619 E	Air-driven pump Hand operated pump			Hand operated oil injector
					Oil injection kit
					Oil injection set

Hydraulic accessories

To enable the hydraulic tools to suit most applications, SKF offers a wide range of accessories. This range includes pressure gauges, reading up to 400 MPa (58,000 psi), which help ensure the simple and accurate monitoring of pressures and forces. To enable pumps and injectors to be connected to many different applications, such as AOH withdrawal sleeves, a wide range of high-pressure pipes, connection nipples and extension pipes is available.

Mounting and dismounting fluid

The SKF mounting and dismounting fluids are formulated for use with the SKF hydraulic equipment including hydraulic pumps, HMV nuts and oil injection tools. Both products contain anti corrosives which are non aggressive to seal materials such as nitrile rubber, leather, chrome leather and PTFE.

Adapter and withdrawal sleeves for Oil Injection

SKF sleeves can include the facility to use the SKF Oil Injection Method. The larger sleeves have oil supply ducts and distribution grooves, allowing oil to be injected between the sleeve and bearing bore and between the sleeve and shaft. This oil reduces friction and the force required for mounting and dismounting.

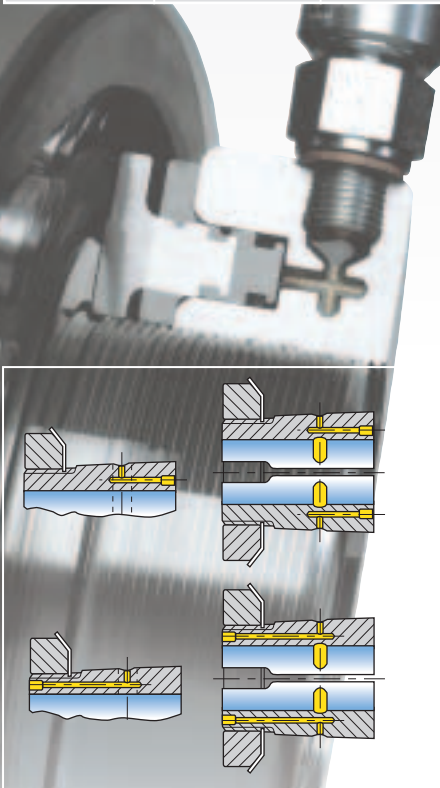

Different arrangements of oil supply ducts in sleeves

SKF Support

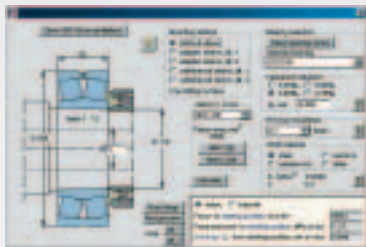

The SKF Oil Injection CD-ROM

This CD-ROM, publication number MP3601, contains a calculation program, which easily computes the calculations necessary for the SKF Oil Injection Method. The CD-ROM provides detailed instructions and practical information on how to use the SKF Oil Injection Method for mounting and dismounting bearings. It also provides theoretical details behind the method plus information on designing components, practical experiences, application examples and more. The program also includes animations, photographs, detailed product information and instructions-for-use, as well as video clips showing various methods and techniques.

The SKF Drive-up Method CD-ROM

This CD-ROM, publication number MP3600, is used to calculate the required pressure to reach the starting position in, MPa or psi, and the axial drive up distance in, mm and inch. It completes the calculations for bearings mounted on solid or hollow shafts, shafts made of steel or other materials, direct on shafts or fitted on adapter or withdrawal sleeves. Additionally, the internal clearance reduction can be user specified. The CD-ROM is multi-lingual, including calculations in English, German, Swedish, French, Italian, Spanish and Portuguese languages. It also includes explanations of the method, video clips, animations and application examples.

Online Mounting and Dismounting Instructions

At Internet skf.com/mount, SKF offers a unique Web-based, free of charge information service for the mounting and dismounting of SKF bearings and bearing housings in eight languages. This service provides step-by-step instructions for mounting or dismounting. The system also provides information on proper tools and lubricants. With this free Internet based service; SKF's expertise is at your fingertips around the clock worldwide.

SKF Maintenance and Lubrication Products catalogue

This catalogue, publication number MP3000, contains detailed information and technical data of the entire range of bearing maintenance and lubrication products available from SKF. The catalogue is available in several languages, printed as well as online at www.mapro.skf.com. In addition to the catalogue, this Internet site offers a wealth of information on bearing maintenance practices as well as an extensive "frequently asked questions" section.

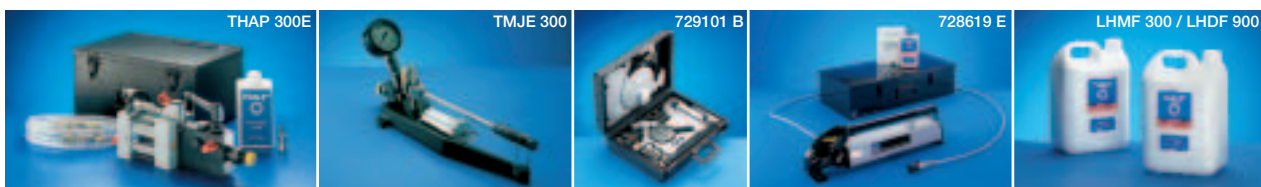

In line with our policy of continuous development of our products we reserve the right to alter any part of the above specification without prior notice.

Although care has been taken to ensure the accuracy of this publication, SKF does not assume any liability for errors or omissions.

SKF Maintenance Products

© Copyright SKF 2003/06 www.mapro.skf.com
www.skf.com/mount

