



/// RotoPRECISION Inc.



SUPER PRECISION ANGULAR CONTACT BEARINGS

SNFA Product Range Quick Series Interchange and Page Reference

SERIES	SNFA	FAG	BARDEN	FAFNIR	GMN	NSK	RHP	SKF	SNR	PAGE
ISO 18	SEA	B 71800	--	--	--	--	--	71800	71800	24
ISO 19	SEB	B 71900	1900 H	9300 WI	S 61900	7900	7900	71900	71900	25
ISO 19	VEB, HB	HS 71900	--	99300 WN	--	BNC 19	XS 7900	71900 CE	--	26, 28
ISO 19	HB../S	HSS 71900	--	--	--	--	--	S 71900 B	--	28
ISO 10	EX	B 7000	100 H	9100 WI	S 6000	7000	7000	7000	7000	30
ISO 10	VEX, HX	HS 7000	--	99100 WN	SH 6000	BNC 10	X-T 7000	7000 CC 7000 CE	--	31, 33
ISO 10	VEX../S HX../S	HSS 7000	--	--	--	--	--	S 7000 B S 7000 C	--	31, 33
ISO 02	E200	B 7200	200 H	200 WI	S 6200	7200	7200	7200	7200	35
ISO 02	BS200	76020	--	--	--	--	--	BSA 2	--	36

*** Please note:** The interchange table provided is intended as a quick reference for general information purposes only and does not in any way guarantee that all bearings will perform to the same operating standards.





CONTACT BEARINGS



SUPER PRECISION ANGULAR

- The SNFA Group (2)
- Technology (3)
- Quality System (7)
- CHROMEX®40 - A New Material for Spindle Bearings (8)
- Ceramic Material (10)
- VEB and VEX High Speed Bearings in "H1" and "G1" Air - Oil Lubrication (11)
- Sealed Bearings (12)
- Product Range and Table of Equivalents (14)
- Symbols and Units (15)
- Precision Tables (ABEC5 - ABEC7 - ABEC9) (16)
- Assembly Tolerances (17)
- Errors of Form (18)
- Grease Quantity (19)
- Bearing Marking and Packaging (20)
- Bearing Identification Code (21)
- ISO Series and SNFA Production (22)
- Limiting Speed and Preload Calculation (23)
- SNFA Bearing Tables: SEA Series (24)
- SEB Series (25)
- VEB Series (26)
- VEB/NS, VEB/XN Series (27)
- HB, HB/S Series (28)
- HB/NS, HB/S/NS, HB/S/XN Series (29)
- EX Series (30)
- VEX, VEX/S Series (31)
- VEX/NS, VEX/S/NS, VEX/S/NX Series (32)
- HX, HX/S Series (33)
- HX/NS, HX/S/NS, HX/S/XN Series (34)
- E 200 Series (35)
- Ball Screw Support Bearings BS200, BS200/S, BS (Special) Series (36)
- Ball Screw Bearing Cartridge Units BSDU, BSQU, BSQU/1 Series (37)





THE SNFA GROUP

Since 1952, the SNFA Group has distinguished itself in the market of high performance ball and roller bearings and has gradually implemented an organizational structure specializing in:

- Special ball and roller bearings for the aerospace and related industries;
- High-precision angular contact ball bearings for machine tools and similar applications.

Over the years, the high level of expertise in these two fields has allowed the development of often unique technologies for the design and manufacture of bearings to the highest quality.

In Italy, the SNFA Group is represented by Somecat S.p.A., who, along with its sister company in the UK, SNFA Bearings Ltd., is a leading manufacturer of super precision angular contact bearings primarily for machine tools.

PRODUCTION UNITS

 **SNFA SA** (France)
Aerospace bearings

 **Somecat S.p.A.** (Italy)
Precision ball bearings

 **SNFA Bearings Ltd.** (U.K.)
Precision ball bearings

MARKETING UNITS

 **SNFA SA** (France)
*Aerospace bearings /
Precision ball bearings*

 **Somecat S.p.A.** (Italy)
Precision ball bearings

 **SNFA Bearings Ltd.** (U.K.)
Precision ball bearings

 **SNFA Präzisions -
Wälzlager** (Germany)
Precision ball bearings

 **SNFA S.A. Fribourg**
(Switzerland)
Precision ball bearings



The Technology. . .

State-of-the-art technology and constant upgrading is applied throughout the SNFA Group.



Each process, from design to testing, from manufacturing to inspection, is within a procedure that benefits from the necessary resources and facilities.

Grinding and superfinishing are part of a complex cycle of operations involving all the surfaces of the bearing rings and these operations require the use of special high-quality CNC machinery. For this reason, a new area within the Somecat facility was developed using state-of-the-art technologies.

Rings are manufactured from bar, tube or forging. The most common raw material used is 100Cr6 that must be of the highest quality and inclusion free.





Matching is the operation whereby two or more bearings are brought together for preloading into sets.

In order to obtain a precise preloading, SNFA uses specialized equipment and the whole process is strictly controlled.

Cotton fabric reinforced phenolic resin cages are machined from tube. Good dynamic behaviour of this vital bearing component depends on raw material homogeneity and precise geometry being obtained during manufacture.

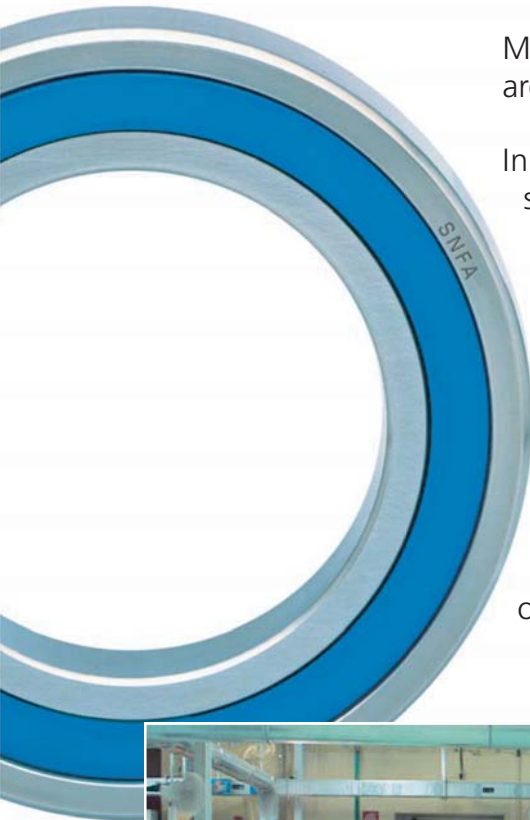



Final inspection of rings is performed under environmentally controlled conditions using specialized equipment that simultaneously measures all geometric parameters.

Marking ensures complete identification of the product.





Product design, from analysis computer programs through to laboratory testing, is performed in line with criteria conforming to ISO 9000 standards.

Functional tests are carried out in the SNFA laboratories and are targeted at finding new and innovative solutions for the benefit of our customers.

SNFA already offers its customers the technology for optimizing the choice of bearings during the design stage of a new application.

Recently SNFA has developed a new program, SECBA, that analyzes bearing performance by taking into account the whole of the spindle assembly.



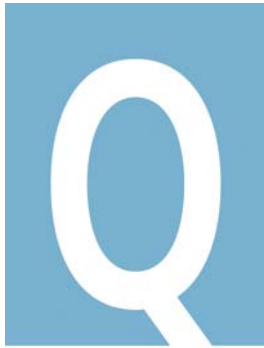

The Quality System

All of SNFA production is under quality management systems audited and approved to ISO 9001:2000 standards that encompass safety, environment, human resource and continuous improvement strategies. This striving for excellence by Somecat and SNFA Bearings Ltd. testifies that Total Quality is the main feature of the companies' production activities.



CERTIFICATE

IoNet and its partner CISQ/ICIM hereby certify that the organization **SOMECAT S.p.A.** Via Savonera Druento, 15 I-10044 PIANEZZA (TO) for the following field of activities **Design and production of high precision ball bearings.** has implemented and maintains a **Quality Management System** which fulfills the requirements of the following standard **ISO 9001** Issued on: 2001-12-12 Validity date: 2004-12-11 Registration Number: IT-3910



IoNet partners: SENOR, Spain; AFAD, France; ABB, Belgium; International, Belgium; AFPCR, Portugal; CISQ, Italy; CQC, China; CEIM, China; CCR, Czech Republic; DQS, Germany; IIR, Denmark; IUT, Germany; PCAV, Brazil; FOUNGONGBA, Hong Kong; INELSA, Hong Kong; IONTEC, Colombia; SISA, Argentina; ICA, Spain; SISA, Argentina; SIO, Korea; MSST, Germany; MCS, Slovenia; SQA, Ireland; QCR, Austria; PCSC, Finland; PBR, Singapore; SPS, Finland; SII, Israel; SIO, Slovenia; SQA, Switzerland; IQNet is represented in the CISQ by the following partners: AFAG, ABB, Belgium; International, CISQ, DQS, Korea and PCSC.

*The list of IoNet partners is valid at the time of issue of this certificate. Updated information is available under www.ioqnet.com

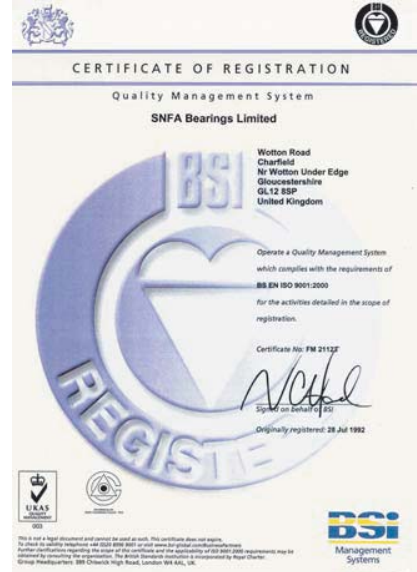

CHROMEX®40

This special highly-alloyed steel, resulting from the most advanced aeronautical and aerospace technologies, now also allows for the production of precision bearings for machine tools. Its innovative composition, with elements such as molybdenum, chromium, vanadium and nitrogen, allows for a more homogeneous structure and increases its resistance to fatigue and corrosion.

Chromex®40 is the most reliable, stable and innovative solution for high performance of bearings in machine tools and electrospindles.

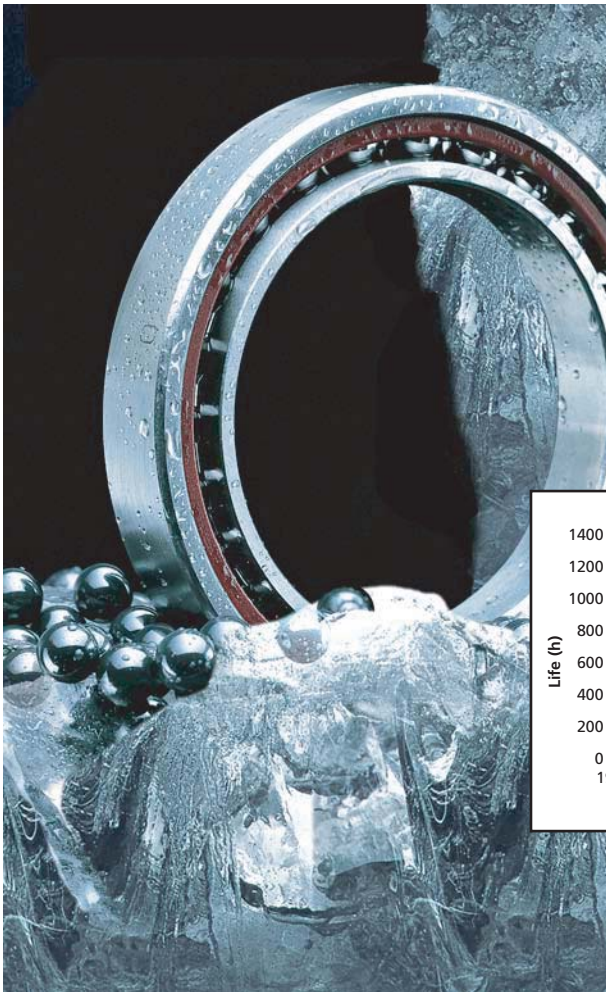
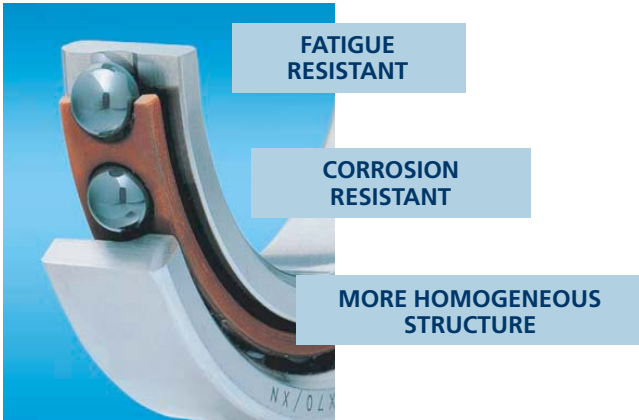

- 100Cr6 = L_{10h}
- 100Cr6 + NS = $L_{10h} \times 2$
- Chromex® 40 + NS = $L_{10h} \times 5$

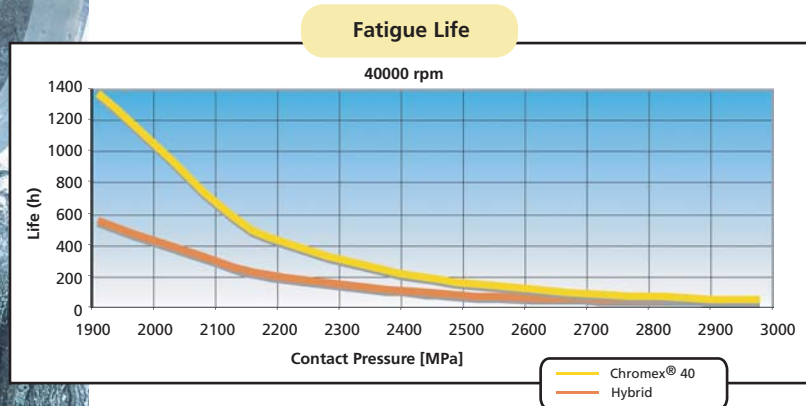
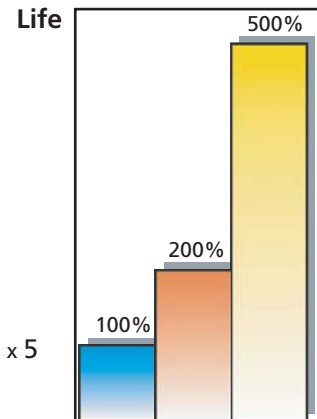



Centrifugal Force

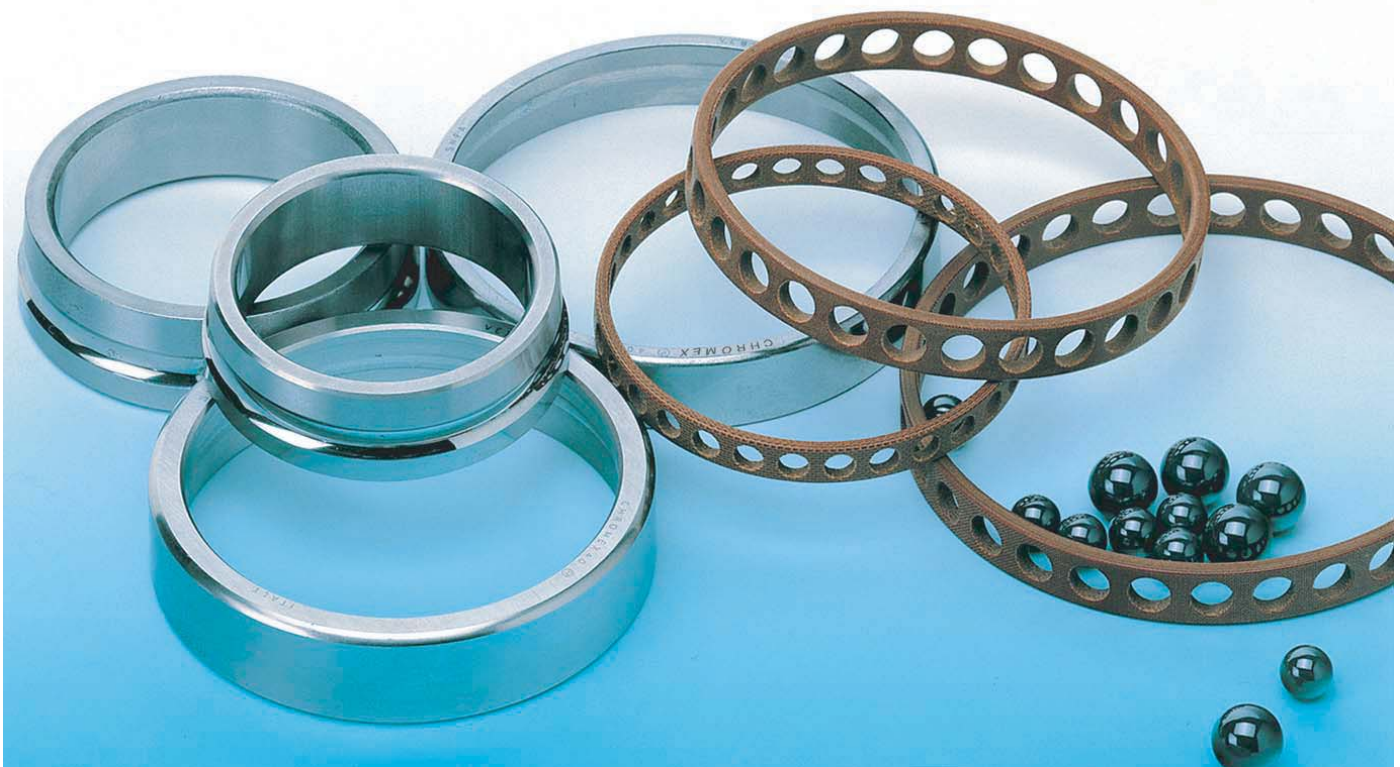
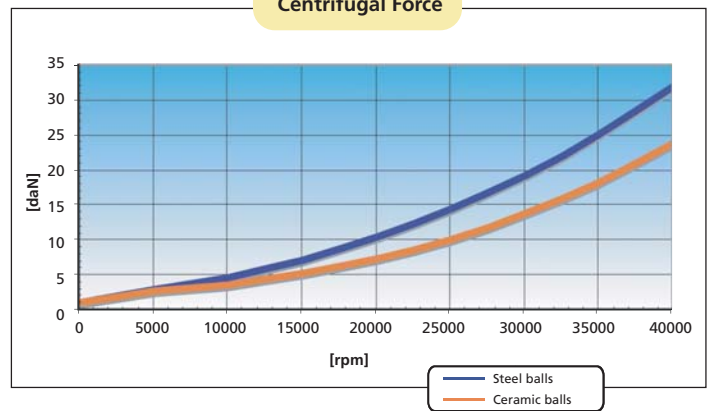

Ceramic Material



Ceramic material balls are essential components of bearings for high-speed applications, as they represent a perfect combination in terms of density, resistance and life. Thanks to the low density of the ceramic material, 40% of that of steel, the balls develop lower centrifugal forces that result in reduced contact friction thus enabling higher speed and durability.

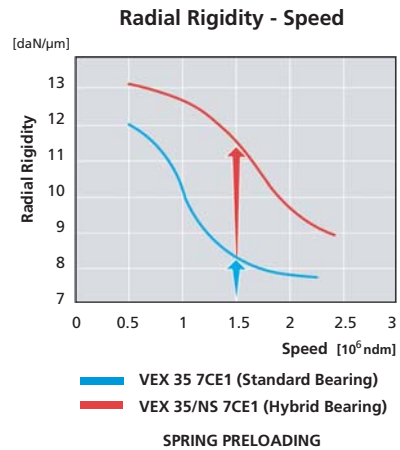
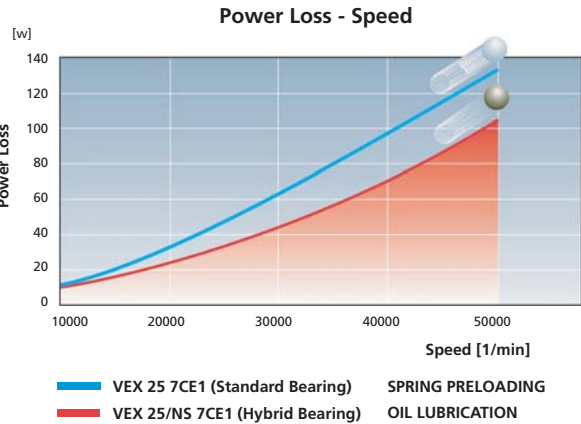

Material Characteristics Data

				SILICON NITRIDE	BEARING STEEL
Density	ρ	[g/cm ³]	--	3.19	7.80
Linear Thermal Expansion	α	[10 ⁻⁶ /°C]	20 - 1000°C	3.20	--
			20 - 300°C	--	11
Modulus of Elasticity	E	[kN/mm ²]	20°C	315	210
Poisson's Ratio	ν	--	--	0.26	0.30
HV10 Hardness	--	[MN/m ^{1.5}]	20°C	1700	700
Impact Strength	K_{IC}	[W/m°C]	20°C	6 - 8	25
Thermal Conductivity	λ	--	20°C	30 - 40	40 - 50
Limiting Temperature	--	°C	--	ca. 1000	ca. 300
Hardness in Hot Condition	--	--	--	good	bad
Dimensional Stability	--	--	--	good	good
Corrosion Resistance	--	--	--	good	bad
Magnetism	--	--	--	absent	present
Electrical Insulation	--	--	--	good	bad

Friction due to rolling elements in hybrid bearings is lower than in steel ball bearings. Therefore hybrid bearings need a smaller quantity of oil for lubrication. These favourable characteristics result in a significant reduction of absorbed power.

**VEB and VEX Bearings For High Speed
In "H1" and "G1" Air-Oil Lubrication**

High-speed operation requires efficient lubrication to ensure the presence of oil in the critical areas of the bearing, namely contact between raceway and rolling elements.

In these areas, because of high pressures and sliding effects, it is necessary to guarantee the separation of contacting surfaces by an oil film. The most traditional solution, the injection of the oil or of air-oil from nozzles, can result in lubricant dispersion due to the effects of wind at high rotational speeds (Fig. 1).

The opportunity to run the air-oil flow directly into the bearing by means of radial holes in the outer rings becomes beneficial.

VEB and VEX bearings, predisposed for this solution, take the "H1" (Fig. 2) or "G1" (Fig. 3) codes in their designation. The radial oil-feed holes and o-rings in the outer ring serve to:

- facilitate the design of oil supply circulation in the spindle body;
- inject the lubricating flow directly at the high pressure points of contact;
- keep the cage location lubricated;
- minimize pressure losses of the air-oil flow.

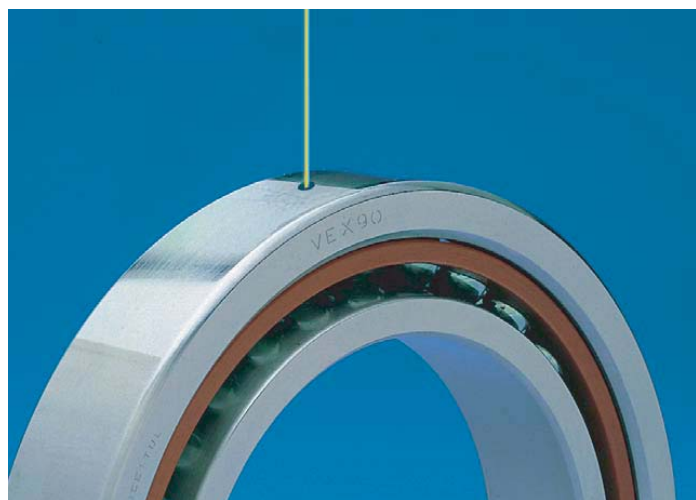
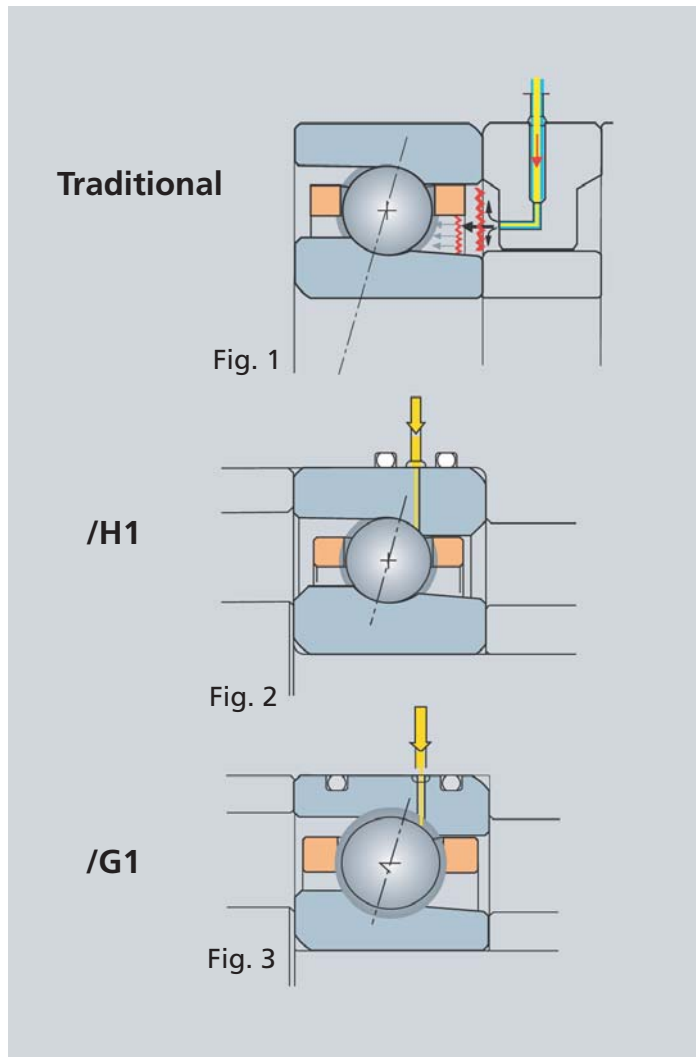



Sealed Bearings

Sealed bearings produced by SNFA offer several advantages in terms of reliability and safety. Seals protect the bearing from the infiltration of contaminants and from lubricant deterioration.

Furthermore, the existing space between the cage and the seals creates a reservoir of grease that ensures high performance and a longer working life.

The SNFA sealed bearing production is currently the ISO 10 and ISO 19 series.



Sealed Bearings (Continued)

The main causes reducing the actual working life of bearings are owing to:

- bearing contamination with particles from washing;
- residual moisture;
- lubricant contamination;
- use of lubricants that are unsuitable for the operating conditions, or the properties of which have deteriorated;
- lubricant removal and deterioration by the air flow from blown seals during operation.

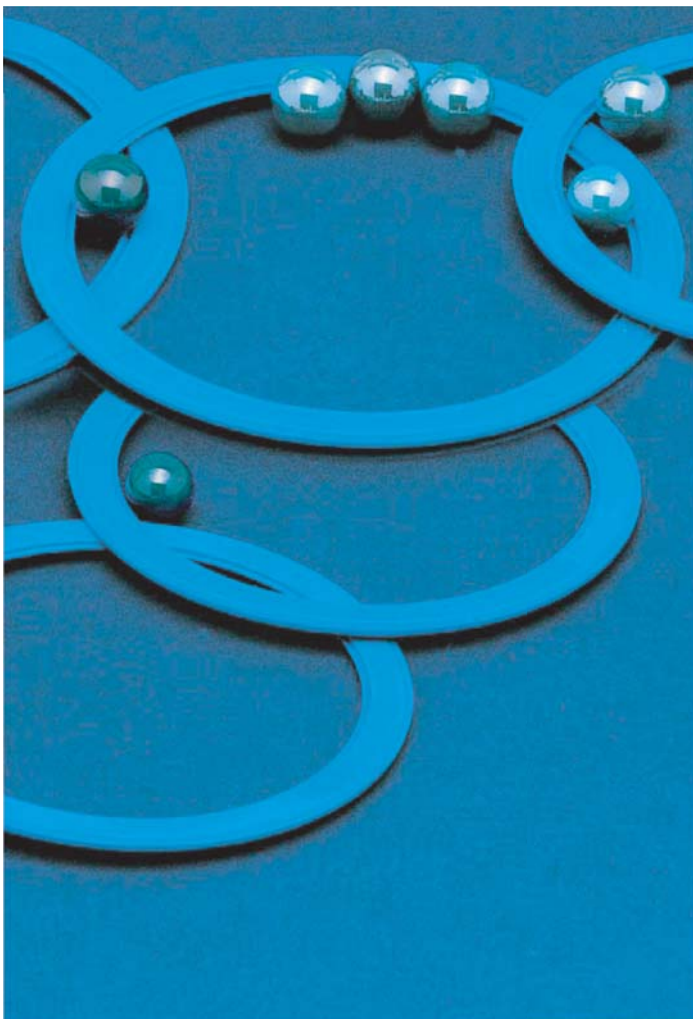

The series that SNFA is currently producing are the most suitable versions for high rotational speed. This is the operational area in which it is most important to ensure that there are no contaminants inside the bearing, and that the correct type and quantity of grease are used.

Seals have been designed purposely to optimize the inner dimensions of the bearing and so maintain operational reliability.

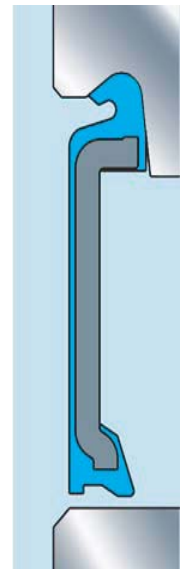



SNFA Product Range and Interchange Table



SERIES (SNFA)	ISO	FEATURES
SEA	18	Minimum overall dimensions. Radial-axial load 1 500 000 ndm (oil).
SEB	19	Reduced overall dimensions. Radial-axial load 1 500 000 ndm (oil).
VEB	19	Reduced overall dimensions. Very high speed (over 2 000 000 ndm, oil).
HB	19	Very high speed (> 2 000 000 ndm) with oil direct lubrication through outer ring and O-ring (../GH). Grease lubrication with seals (../S).
EX	10	High load capacity. Radial-axial load 1 500 000 ndm (oil).
VEX	10	Good radial-axial load capacity. Very high speed (over 2 000 000 ndm) with oil direct lubrication. Radial-axial load 1 600 000 ndm with grease lubrication with seals (../S).
HX	10	Very high speed (> 2 000 000 ndm) with oil direct lubrication through outer ring and O-ring (../GH). Grease lubrication with seals (../S).
E 200	02	Very high load capacity. Radial-axial load 1 500 000 ndm (oil).
BS 200	02	High axial rigidity and load capacity. Predominantly axial load.
BS (Special)	--	As BS 200.

SERIES	SNFA	FAG	BARDEN	FAFNIR	GMN	NSK	RHP	SKF	SNR
ISO 18	SEA	B 71800	--	--	--	--	--	71800	71800
ISO 19	SEB	B 71900	1900 H	9300 WI	S 61900	7900	7900	71900	71900
ISO 19	VEB, HB	HS 71900	--	99300 WN	--	BNC 19	XS 7900	71900 CE	--
ISO 19	HB../S	HSS 71900	--	--	--	--	--	S 71900 B	--
ISO 10	EX	B 7000	100 H	9100 WI	S 6000	7000	7000	7000	7000
ISO 10	VEX, HX	HS 7000	--	99100 WN	SH 6000	BNC 10	X-T 7000	7000 CC 7000 CE	--
ISO 10	VEX../S HX../S	HSS 7000	--	--	--	--	--	S 7000 B S 7000 C	--
ISO 02	E 200	B 7200	200 H	200 WI	S 6200	7200	7200	7200	7200
ISO 02	BS 200	76020	--	--	--	--	--	BSA 2	--

*** Please note:** The interchange table provided is intended as a quick reference for general information purposes only and does not in any way guarantee that all bearings will perform to the same operating standards.

Symbols and Units

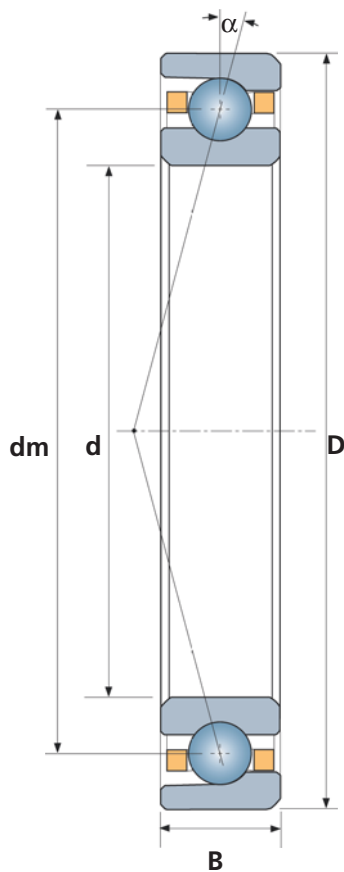

SYMBOL	UNIT	DESCRIPTION
d	mm	Bearing bore diameter
D	mm	Bearing outer diameter
B	mm	Bearing width
α	degrees	Contact angle
dm	mm	Bearing pitch diameter
C_{33}	daN	Dynamic load capacity
C_o	daN	Static load capacity
Ra	daN/μm	Axial rigidity
Vh	rpm	Maximum speed of single bearing, spring preloaded, with oil lubrication, $\alpha = 15^\circ$ (Series BS 200 and BS, $\alpha = 62^\circ$)
Pr	daN	Preload
Cr	daN•mm	Low speed rolling torque for bearing group
M	Kg	Weight
n	rpm	Speed
ndm	rpm•mm	Speed factor

*** Please note:** Any other symbols mentioned in this catalogue are specified in the paragraph they refer to.





Dimensional and Functional Tolerances of Bearings ABEC 5 - ABEC 7 - ABEC 9 (AFBMA STD 20)

Inner Ring

(Values indicated in microns)

Bore in mm		> 0	> 10	> 18	> 30	> 50	> 80	> 120	> 150	> 180	> 250	> 315	> 400
		≤ 10	≤ 18	≤ 30	≤ 50	≤ 80	≤ 120	≤ 150	≤ 180	≤ 250	≤ 315	≤ 400	≤ 500
Δd_{mp}	ABEC 5	-5	-5	-6	-8	-9	-10	-13	-13	-15	-18	-23	--
	ABEC 7	-4	-4	-5	-6	-7	-8	-10	-10	-12	--	--	--
	ABEC 9	-2.5	-2.5	-2.5	-2.5	-4	-5	-7	-7	-8	--	--	--
K_{ia}	ABEC 5	4	4	4	5	5	6	8	8	10	13	15	--
	ABEC 7	2.5	2.5	3	4	4	5	6	6	8	--	--	--
	ABEC 9	1.5	1.5	2.5	2.5	2.5	2.5	2.5	5	5	--	--	--
S_{ia}	ABEC 5	7	7	8	8	8	9	10	10	13	15	20	--
	ABEC 7	3	3	4	4	5	5	7	7	8	--	--	--
	ABEC 9	1.5	1.5	2.5	2.5	2.5	2.5	2.5	5	5	--	--	--
S_d	ABEC 5	7	7	8	8	8	9	10	10	11	13	15	--
	ABEC 7	3	3	4	4	5	5	6	6	7	--	--	--
	ABEC 9	1.5	1.5	1.5	1.5	1.5	2.5	2.5	4	5	--	--	--
V_{Bs}	ABEC 5	5	5	5	5	6	7	8	8	10	13	15	--
	ABEC 7	2.5	2.5	2.5	3	4	4	5	5	6	--	--	--
	ABEC 9	1.5	1.5	1.5	1.5	1.5	2.5	2.5	4	5	--	--	--
ΔB_s	ABEC 5	-40	-80	-120	-120	-150	-200	-250	-250	-300	-350	-400	--
	ABEC 7	-40	-80	-120	-120	-150	-200	-250	-250	-300	--	--	--
	ABEC 9	-40	-80	-120	-120	-150	-200	-250	-300	-350	--	--	--
ΔB_{1s}	ABEC 5	-250	-250	-250	-250	-250	-380	-380	-380	-500	-500	-630	--
	ABEC 7	-250	-250	-250	-250	-250	-380	-380	-380	-500	--	--	--
	ABEC 9	--	--	--	--	--	--	--	--	--	--	--	--

Outer Ring

(Values indicated in microns)

Outer Diameter Ø D in mm		> 0	> 6	> 18	> 30	> 50	> 80	> 120	> 150	> 180	> 250	> 315	> 400
		≤ 6	≤ 18	≤ 30	≤ 50	≤ 80	≤ 120	≤ 150	≤ 180	≤ 250	≤ 315	≤ 400	≤ 500
ΔD_{mp}	ABEC 5	-5	-5	-6	-7	-9	-10	-11	-13	-15	-18	-20	-23
	ABEC 7	-4	-4	-5	-6	-7	-8	-9	-10	-11	-13	-15	--
	ABEC 9	-2.5	-2.5	-4	-4	-4	-5	-5	-7	-8	-8	-10	--
K_{ea}	ABEC 5	5	5	6	7	8	10	11	13	15	18	20	23
	ABEC 7	3	3	4	5	5	6	7	8	10	11	13	--
	ABEC 9	1.5	1.5	2.5	2.5	4	5	5	5	7	7	8	--
S_{ea}	ABEC 5	8	8	8	8	10	11	13	14	15	18	20	23
	ABEC 7	5	5	5	5	5	6	7	8	10	10	13	--
	ABEC 9	1.5	1.5	2.5	2.5	4	5	5	5	7	7	8	--
S_D	ABEC 5	8	8	8	8	8	9	10	10	11	13	13	15
	ABEC 7	4	4	4	4	4	5	5	5	7	8	10	--
	ABEC 9	1.5	1.5	1.5	1.5	1.5	2.5	2.5	2.5	4	5	7	--
V_{Cs}	ABEC 5	5	5	5	5	6	8	8	8	10	11	13	15
	ABEC 7	2.5	2.5	2.5	2.5	3	4	5	5	7	7	8	--
	ABEC 9	1.5	1.5	1.5	1.5	1.5	2.5	2.5	2.5	4	5	7	--
ΔC_s ΔC_{1s}	ABEC 5	VALUES IDENTICAL TO THOSE OF THE CORRESPONDING INNER RING OF THE SAME BEARING											
	ABEC 7												
	ABEC 9												

Note: Bearings with special precision can be offered on request.

Δd_{mp} = Deviation of the mean bore diameter from the nominal ($\Delta d_{mp} = d_{mp} - d$).

ΔD_{mp} = Deviation of the mean outside diameter from the nominal ($\Delta D_{mp} = D_{mp} - D$).

K_{ia} , K_{ea} = Radial runout of assembled bearing inner ring and assembled bearing outer ring, respectively.

S_{ia} , S_{ea} = Side face runout of assembled bearing inner ring and assembled bearing outer ring, respectively.

S_d = Side face runout with reference to bore (of inner ring).

S_D = Outside inclination variation: variation in inclination of outside cylindrical surface to outer ring side face.

V_{Bs} , V_{Cs} = Ring width variation: difference between the largest and smallest single widths of inner ring and of outer ring, respectively.

ΔB_s , ΔC_s = Deviation of single inner ring width or single outer ring width from nominal ($\Delta B_s = B_s - B$ ecc.).

ΔB_{1s} , ΔC_{1s} = Deviation of single width of inner ring and outer ring, respectively, of a bearing specially manufactured for paired mounting and universal bearing ($\Delta B_{1s} = B_s - B$ ecc.).

Shafts and Housings for ABEC 7 - ABEC 9 Bearings

STEEL SHAFTS (Rotating)

Nominal shaft diameter in mm	≥	6	10	18	30	50	80	120	180	250
	<	10	18	30	50	80	120	180	250	315
	Tolerances of shaft diameter in µm	0 -4	0 -4	0 -4	0 -5	0 -5	+2 -4	+3 -5	+4 -6	+5 -7
	ISO	--	--	h3	--	h3	--	--	--	--

STEEL HOUSINGS

Nominal housing diameter in mm	≥	10	18	30	50	80	120	180	250	315
	<	18	30	50	80	120	180	250	315	400
Support locked axially	Tolerances in µm	+5 0	+6 0	+7 0	+8 0	+7 -3	+9 -3	+11 -3	+13 -3	+15 -3
	ISO	H4	H4	H4	H4	--	--	--	--	--
Support free axially	Tolerances in µm	+7 +2	+8 +2	+9 +2	+10 +2	+10 0	+12 0	+14 0	+16 0	+18 0
	ISO	--	--	--	--	H4	H4	H4	H4	H4

Shafts and Housings for ABEC 5 Bearings

SHAFTS (Rotating)

Nominal shaft diameter in mm	≥	6	10	18	30	50	80	120	180	250
	<	10	18	30	50	80	120	180	250	315
	Tolerances of shaft diameter in µm	0 -5	0 -5	0 -6	0 -7	0 -8	+3 -7	+4 -8	+5 -9	+6 -10
	ISO	--	h4	h4	h4	h4	--	--	--	--

STEEL HOUSINGS

Nominal housing diameter in mm	≥	10	18	30	50	80	120	180	250	315
	<	18	30	50	80	120	180	250	315	400
Support locked axially	Tolerances in µm	+8 0	+9 0	+11 0	+13 0	+12 -3	+14 -4	+16 -4	+19 -4	+21 -4
	ISO	H5	H5	H5	H5	--	--	--	--	--
Support free axially	Tolerances in µm	+10 +2	+11 +2	+13 +2	+15 +2	+15 0	+18 0	+20 0	+23 0	+25 0
	ISO	--	--	--	--	H5	H5	H5	H5	H5

* **Please note:** For special applications, please consult our Application Support Services.

**Errors of Form:
Maximum Permissible Theoretical Tolerance**

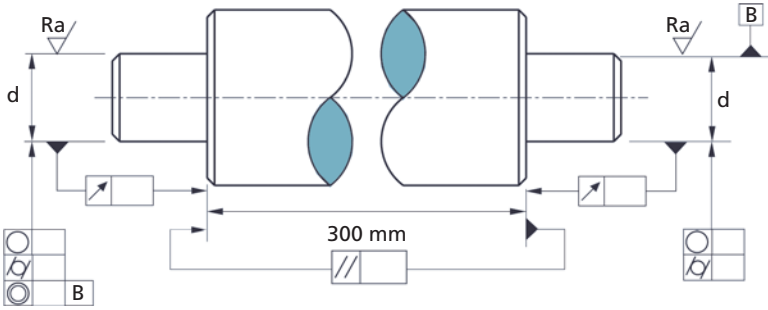

	ISO 1101	ABEC 5	ABEC 7	ABEC 9
\bigcirc	Circularity	$\frac{IT\ 3}{2}$	$\frac{IT\ 2}{2}$	$\frac{IT\ 1}{2}$
///	Cylindricity	$\frac{IT\ 3}{2}$	$\frac{IT\ 2}{2}$	$\frac{IT\ 1}{2}$
\nearrow	Run-out	IT 3	IT 2	IT 1
//	Parallelism	IT 3	IT 2	IT 1
◎	Concentricity	IT 4	IT 3	IT 2
Ra	Roughness	0.4 μm	0.4 μm	0.2 μm

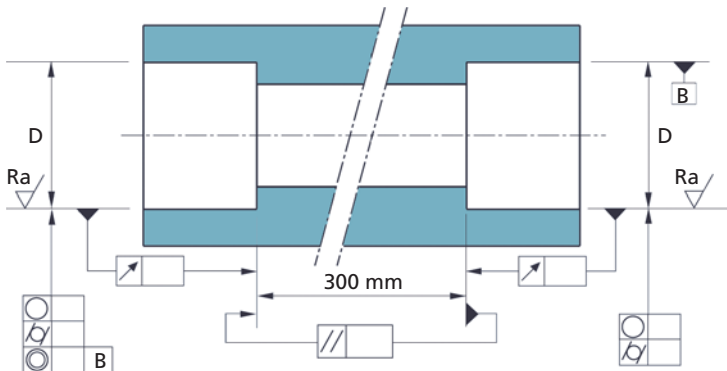

	ISO 1101	ABEC 5	ABEC 7	ABEC 9
\bigcirc	Circularity	$\frac{IT\ 3}{2}$	$\frac{IT\ 2}{2}$	$\frac{IT\ 1}{2}$
///	Cylindricity	$\frac{IT\ 3}{2}$	$\frac{IT\ 2}{2}$	$\frac{IT\ 1}{2}$
\nearrow	Run-out	IT 3	IT 2	IT 1
//	Parallelism	IT 3	IT 2	IT 1
◎	Concentricity	IT 4	IT 3	IT 2
Ra	Roughness	0.8 μm	0.4 μm	0.4 μm

Nominal Diameter in mm	\geq	6	10	18	30	50	80	120	180	250	315
	$<$	10	18	30	50	80	120	180	250	315	400
Tolerance of form in μm	IT 0	0.6	0.8	1	1	1.2	1.5	2	3	--	--
	IT 1	1	1.2	1.5	1.5	2	2.5	3.5	4.5	6	7
	IT 2	1.5	2	2.5	2.5	3	4	5	7	8	9
	IT 3	2.5	3	4	4	5	6	8	10	12	13
	IT 4	4	5	6	7	8	10	12	14	16	18

Grease Quantity

The amount of grease to be introduced into the bearing depends on operating speed.

The amount is calculated by multiplying factor **K**, a function of maximum rotation speed, expressed in "ndm" (Fig. 1) by the "reference quantity" bore and bearing series function as shown in the diagram (Fig. 2).

In the case of small bearings where grease quantities are very small, it is advised that before greasing, the bearings are immersed in a grease solution (containing 3÷5% of grease) then removed and allowed to drain (and the solvent to evaporate) before applying the grease. This ensures that all the bearing surfaces are covered with a thin layer of the lubricant.

Factory - Greased Bearings

SNFA bearings are very often supplied with the type and amount of grease as specified by the customer, both in open and sealed versions (./S), if available.

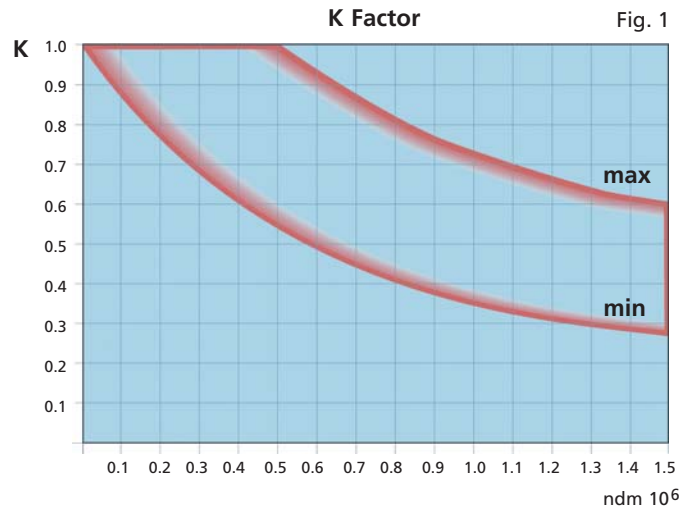

* Please Note: The bearing's mating parts must allow the excess of grease to move outside.

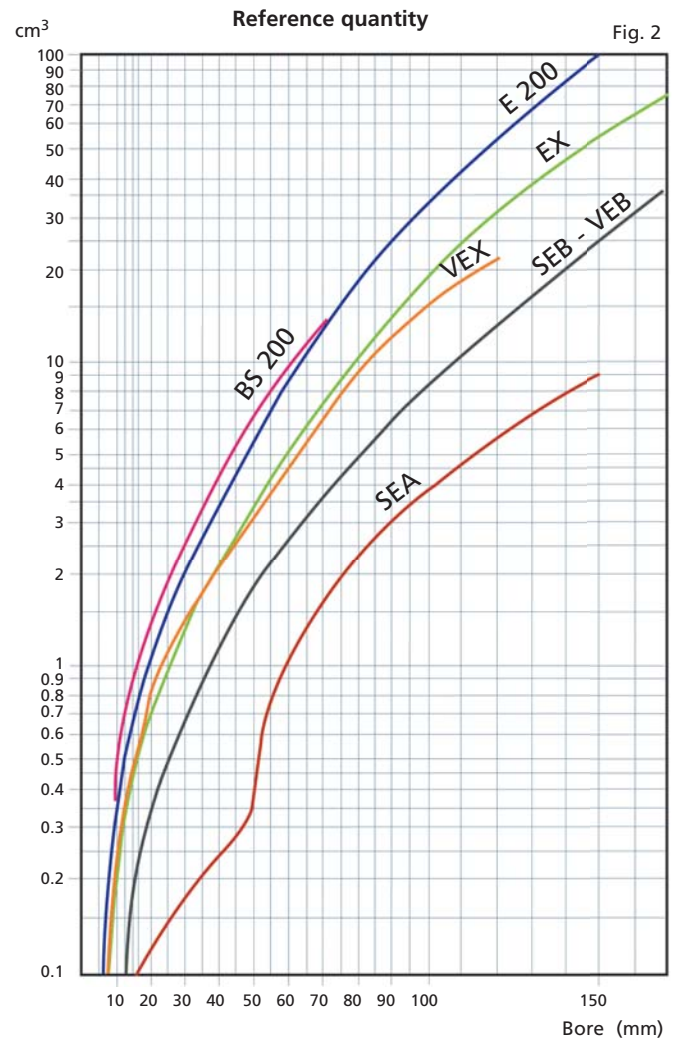

Bearing Marking - Individual Bearings and Bearing Groups

Bearing designation is placed on the wider face of the outer ring. Complete designation (contact angle, precision, arrangement, type, etc.) of medium - large size bearing sets is marked on one bearing only. The remaining bearings of the group have markings indicating: type, trade mark and country of origin only.

Micron deviations from the nominal value of each bore and outside diameter are marked on that surface, at the point of maximum eccentricity (maximum radial thickness).

Maximum assembly concentricity is obtained by locating this point at 180° to maximum shaft or housing eccentricity. Other markings that may appear on ring faces are manufacturing references (manufacturing date, serial number, etc.).

*** Please Note:** The "V" arrow on the bearing outer diameter indicates the direction of thrust applicable to the inner rings of the bearing group. The arrow is placed at the point of maximum outer ring eccentricity.

Boxes and Packaging

SNFA bearings are normally packaged in individual boxes, even when they belong to a bearing set. In this case, boxes are grouped together. Marking is with labels applied to each of the boxes. The label bears the following information:

- bearing set designation;
- grease type (for SNFA greased bearings);
- packaging date;
- actual contact angle (for single Universal bearings only).

Boxes are cardboard and are marked with the SNFA trade name and the description "Precision Bearings." The box contains bearing mounting instructions (in four languages).

Bearings with ceramic material balls or with Chromex® 40 rings are contained in boxes bearing a red or yellow colour label with the wording "CERAMIC" or "CHROMEX® 40."

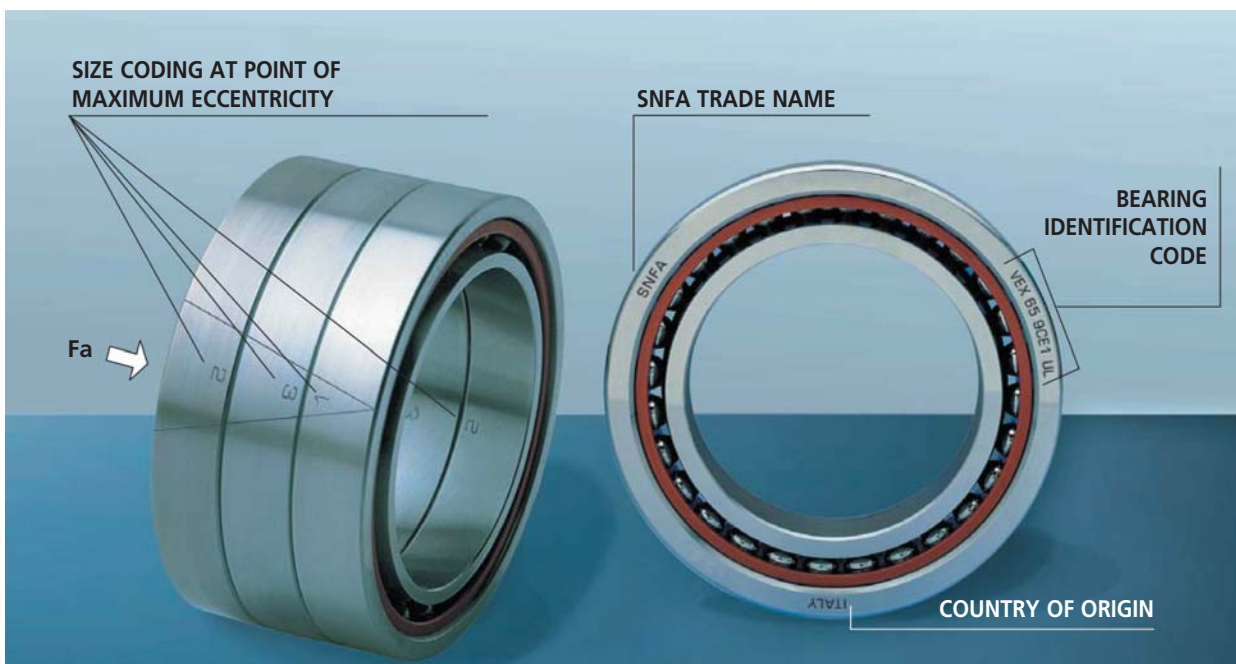

Bearing Identification Code

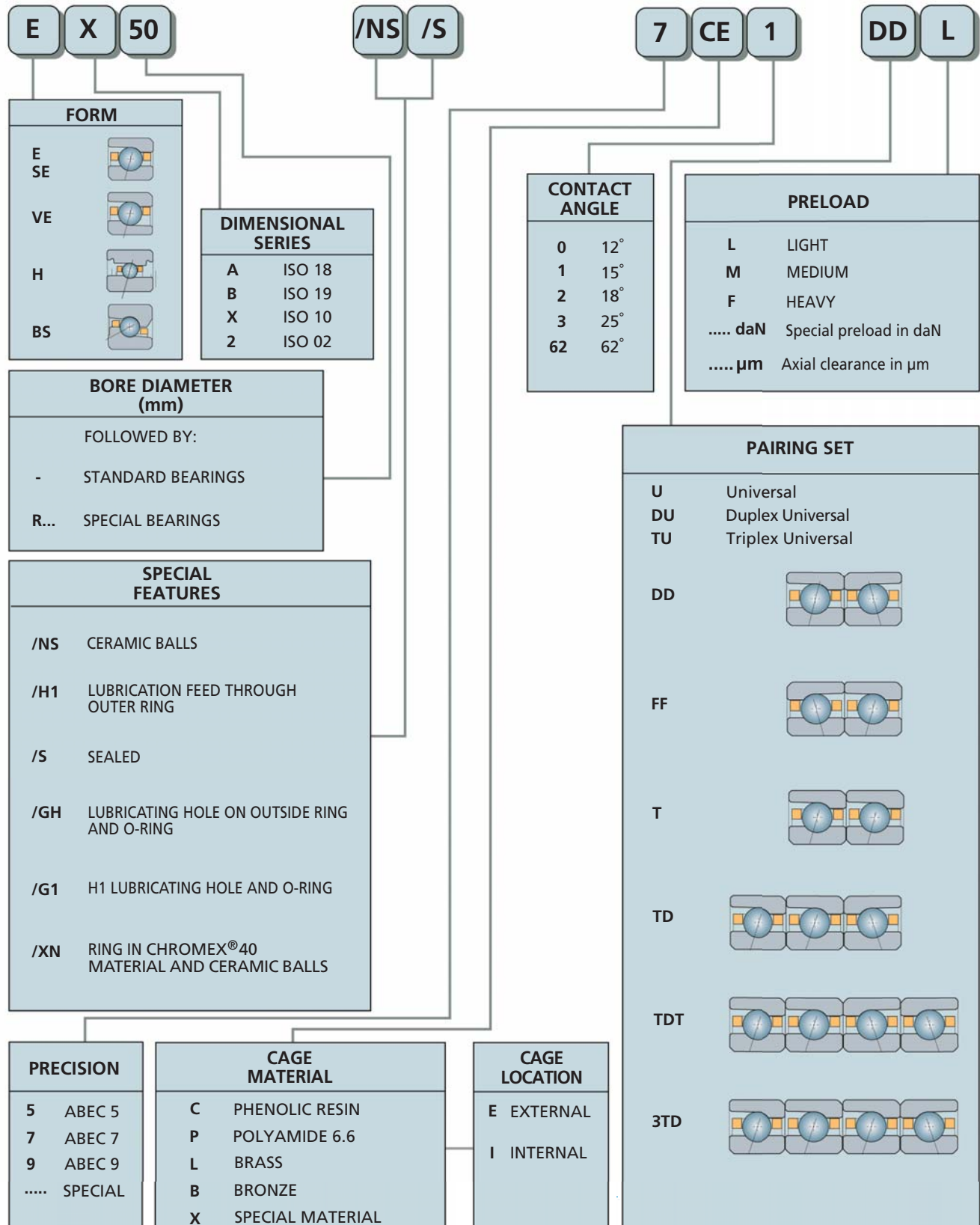



ISO Series and SNFA Production

Ø BORE	ISO 18		ISO 19		ISO 10		ISO 02	
	D	B	D	B	D	B	D	B
6								
7								
8								
9								
10	SEA							
12								
15								
17								
20								
25								
30								
35								
40								
45								
50								
55								
60								
65								
70								
75								
80								
85								
90								
95								
100								
105								
110								
120								
130								
140								
150								
160								
170								
180								
190								
200								
220								
240								
260								
280								

Limiting Speed Calculation

$$n_{max} [rpm] = V_h \cdot K_1 \cdot K_2 \cdot K_3 \cdot K_4$$

	K₁		K₂			K₃		K₄	
	Arrangement and Preload		Precision			Lubrication		Contact Angle	
	SEA - SEB - VEB EX - VEX - E200 BS200 - BS	HX - HB	SEA - SEB - VEB EX - VEX - E200 HX - HB	BS200 - BS		ALL	SEA - SEB - VEB EX - VEX - E200 HX - HB	BS200 - BS	
T	0.90	0.90							
DDL - FFL	0.80 - 0.77	0.83 - 0.80							
TDL - TFL	0.72 - 0.66	0.75 - 0.66	ABEC 9	1.00	-	oil	1.00	15°	1.00
TDTL - TFTL	0.64 - 0.62	0.67 - 0.64							
DDM - FFM	0.65 - 0.61	0.78 - 0.74	ABEC 7	0.90	1.00				62° 1
TDM - TFM	0.58 - 0.49	0.70 - 0.60							
TDTM - TFTM	0.54 - 0.48	0.64 - 0.60	ABEC 5	0.81	0.90	grease	0.65	25°	0.90
DDF - FFF	0.40 - 0.36	0.58 - 0.54							
TDF - TFF	0.36 - 0.24	0.52 - 0.40							
TDTF - TFTF	0.34 - 0.27	0.49 - 0.41							

Bearing Preload Calculation

$$Pr [daN] = C_{33} \cdot K_5$$

$$Pr [daN] = C_0 \cdot K_5$$

Preload	SEA - SEB - VEB - EX - VEX - E200		HB - HX		BS200 - BS	
	K₅		K₅		K₅	
	Contact Angle		Contact Angle		Contact Angle	
	15°	25°	15°	25°	62°	
L Light	0.005	0.009	0.0032	0.0054	0.0111	
M Medium	0.015	0.027	0.0065	0.0109	0.0335	
F Heavy	0.031	0.053	0.0194	0.0328	0.0670	

SEA ISO 18



SNFA	d	D	B	R _{min}	r _{min}	$\alpha = 15^\circ$		$\alpha = 25^\circ$		V _h (ABEC 9)
						C ₃₃	C ₀	C ₃₃	C ₀	
SEA 10	10	19	5	0.3	0.1	190	125	185	119	121 000
SEA 12	12	21	5	0.3	0.1	210	150	200	143	106 000
SEA 15	15	24	5	0.3	0.1	235	189	220	179	89 500
SEA 17	17	26	5	0.3	0.1	240	200	230	193	81 000
SEA 20	20	32	7	0.3	0.1	390	340	370	320	66 500
SEA 25	25	37	7	0.3	0.1	420	410	400	390	55 500
SEA 30	30	42	7	0.3	0.1	450	480	425	450	48 000
SEA 35	35	47	7	0.3	0.1	470	550	445	520	41 500
SEA 40	40	52	7	0.3	0.1	490	620	465	590	36 500
SEA 45	45	58	7	0.3	0.1	500	670	470	630	33 000
SEA 50	50	65	7	0.3	0.1	750	1 000	710	950	29 500
SEA 55	55	72	9	0.3	0.1	1 045	1 380	985	1 310	26 000
SEA 60	60	78	10	0.3	0.1	1 370	1 800	1 290	1 700	24 000
SEA 65	65	85	10	0.6	0.3	1 375	1 890	1 295	1 780	22 000
SEA 70	70	90	10	0.6	0.3	1 410	2 030	1 330	1 920	20 500
SEA 75	75	95	10	0.6	0.3	1 450	2 170	1 365	2 050	19 400
SEA 80	80	100	10	0.6	0.3	1 485	2 320	1 395	2 180	17 800
SEA 85	85	110	13	1.0	0.3	2 200	3 220	2 070	3 040	16 700
SEA 90	90	115	13	1.0	0.3	2 210	3 350	2 090	3 160	15 600
SEA 95	95	120	13	1.0	0.3	2 245	3 470	2 110	3 280	15 000
SEA 100	100	125	13	1.0	0.3	2 305	3 710	2 165	3 500	14 400
SEA 105	105	130	13	1.0	0.3	2 320	3 830	2 180	3 610	13 600
SEA 110	110	140	16	1.0	0.3	3 235	5 200	3 041	4 880	12 800
SEA 120	120	150	16	1.0	0.3	3 365	5 700	3 160	5 400	11 700
SEA 130	130	165	18	1.1	0.6	3 920	6 800	3 690	6 400	10 600
SEA 140	140	175	18	1.1	0.6	4 550	7 900	4 270	7 500	9 800
SEA 150	150	190	20	1.1	0.6	5 200	9 200	4 880	8 700	9 000

For larger sizes and/or ceramic balls, please contact Application Support.

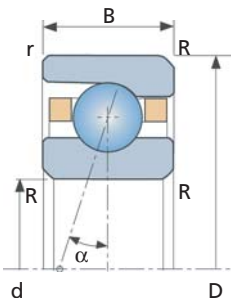

SEB ISO 19



SNFA	d	D	B	R _{min}	r _{min}	$\alpha = 15^\circ$		$\alpha = 25^\circ$		V _h (ABEC 9)
						C ₃₃	C ₀	C ₃₃	C ₀	
SEB 17	17	30	7	0.3	0.15	510	370	485	350	74 000
SEB 20	20	37	9	0.3	0.15	745	580	705	550	60 500
SEB 25	25	42	9	0.3	0.15	765	650	735	620	51 000
SEB 30	30	47	9	0.3	0.15	815	750	765	720	44 500
SEB 35	35	55	10	0.6	0.3	1 115	1 090	1 050	1 030	38 000
SEB 40	40	62	12	0.6	0.3	1 420	1 420	1 340	1 350	33 500
SEB 45	45	68	12	0.6	0.3	1 495	1 600	1 415	1 520	30 000
SEB 50	50	72	12	0.6	0.3	1 925	2 110	1 820	2 010	27 000
SEB 55	55	80	13	1.0	0.3	2 415	2 730	2 280	2 590	24 500
SEB 60	60	85	13	1.0	0.3	2 520	3 020	2 375	2 860	23 000
SEB 65	65	90	13	1.0	0.3	2 550	3 180	2 400	3 010	21 000
SEB 70	70	100	16	1.0	0.3	3 515	4 330	3 315	4 110	19 400
SEB 75	75	105	16	1.0	0.3	3 570	4 560	3 360	4 320	17 800
SEB 80	80	110	16	1.0	0.3	3 620	4 780	3 410	4 520	16 700
SEB 85	85	120	18	1.1	0.6	4 735	6 200	4 460	5 900	15 600
SEB 90	90	125	18	1.1	0.6	4 810	6 500	4 530	6 100	14 400
SEB 95	95	130	18	1.1	0.6	4 880	6 800	4 595	6 400	13 900
SEB 100	100	140	20	1.1	0.6	6 145	8 400	5 795	8 000	13 300
SEB 110	110	150	20	1.1	0.6	6 340	9 200	5 970	8 700	12 200
SEB 120	120	165	22	1.1	0.6	7 515	10 700	7 100	10 200	11 100
SEB 130	130	180	24	1.5	0.6	7 750	11 700	7 280	11 100	10 000
SEB 140	140	190	24	1.5	0.6	7 995	12 600	7 540	12 000	8 900
SEB 150	150	210	28	2.0	1.0	12 080	17 500	11 400	16 600	8 300
SEB 160	160	220	28	2.0	1.0	12 610	19 100	11 895	18 100	7 800
SEB 170	170	230	28	2.0	1.0	12 790	20 000	12 050	18 900	7 200
SEB 180	180	250	33	2.0	1.0	16 315	24 900	15 340	23 600	6 700
SEB 190	190	260	33	2.0	1.0	16 560	26 100	15 600	24 700	6 100
SEB 200	200	280	38	2.1	1.0	20 255	31 100	19 160	29 400	5 600
SEB 220	220	300	38	2.1	1.0	20 695	34 100	19 825	32 300	5 000
SEB 240	240	320	38	2.1	1.0	22 200	38 400	20 900	36 300	4 800
SEB 260	260	360	46	2.1	1.0	29 050	52 900	27 360	50 100	4 300
SEB 280	280	380	46	2.1	1.0	29 300	55 400	27 600	52 500	3 900

For larger sizes and/or ceramic balls, please contact Application Support.

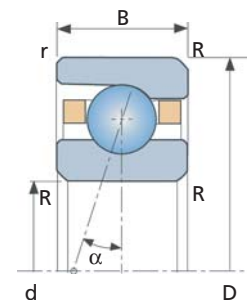

VEB ISO 19

HIGH SPEED SERIES



SNFA	d	D	B	R _{min}	r _{min}	$\alpha = 15^\circ$		$\alpha = 25^\circ$		V _h (ABEC 9)
						C ₃₃	C ₀	C ₃₃	C ₀	
VEB 8	8	19	6	0.3	0.15	178	73	--	--	184 000
VEB 10	10	22	6	0.3	0.15	210	95	198	91	155 000
VEB 12	12	24	6	0.3	0.15	220	107	210	102	137 000
VEB 15	15	28	7	0.3	0.15	330	166	310	158	115 000
VEB 17	17	30	7	0.3	0.15	340	184	330	175	105 000
VEB 20	20	37	9	0.3	0.15	500	290	480	270	86 200
VEB 25	25	42	9	0.3	0.15	540	340	510	320	73 100
VEB 30	30	47	9	0.3	0.15	580	390	540	370	63 400
VEB 35	35	55	10	0.6	0.3	790	560	750	540	54 100
VEB 40	40	62	12	0.6	0.3	1 000	740	950	700	47 500
VEB 45	45	68	12	0.6	0.3	1 050	830	1 000	780	42 700
VEB 50	50	72	12	0.6	0.3	1 310	1040	1 240	980	39 500
VEB 55	55	80	13	1.0	0.3	1 590	1 280	1 500	1 220	35 500
VEB 60	60	85	13	1.0	0.3	1 670	1 420	1 580	1 340	33 000
VEB 65	65	90	13	1.0	0.3	1 690	1 500	1 600	1 420	30 800
VEB 70	70	100	16	1.0	0.3	2 260	1 950	2 130	1 850	27 900
VEB 75	75	105	16	1.0	0.3	2 300	2 050	2 170	1 950	26 300
VEB 80	80	110	16	1.0	0.3	2 340	2 160	2 210	2 040	24 800
VEB 85	85	120	18	1.1	0.6	3 050	2 790	2 880	2 640	22 900
VEB 90	90	125	18	1.1	0.6	3 110	2 930	2 940	2 770	21 800
VEB 95	95	130	18	1.1	0.6	3 170	3 070	2 990	2 900	20 700
VEB 100	100	140	20	1.1	0.6	3 970	3 810	3 760	3 610	19 300
VEB 110	110	150	20	1.1	0.6	4 130	4 170	3 900	3 950	17 500
VEB 120	120	165	22	1.1	0.6	4 860	4 860	4 600	4 600	15 900

For larger sizes, please contact Application Support.

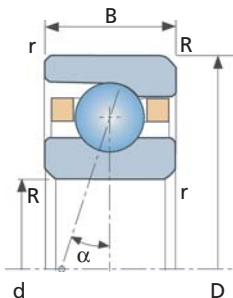

VEB/NS - VEB/XN ISO 19

HIGH SPEED SERIES WITH CERAMIC BALLS

SNFA	d	D	B	R _{min}	r _{min}	$\alpha = 15^\circ$		$\alpha = 25^\circ$		CERAMIC	CHROMEX®40
						C ₃₃	C ₀	C ₃₃	C ₀	V _h (ABEC 9)	V _h (ABEC 9)
VEB 8/NS	8	19	6	0.3	0.15	178	53	--	--	221 000	244 000
VEB 10/NS	10	22	6	0.3	0.15	210	68	198	65	186 000	206 000
VEB 12/NS	12	24	6	0.3	0.15	220	77	210	73	165 000	182 000
VEB 15/NS	15	28	7	0.3	0.15	330	119	310	113	138 000	153 000
VEB 17/NS	17	30	7	0.3	0.15	340	132	330	125	126 000	140 000
VEB 20/NS	20	37	9	0.3	0.15	500	210	480	195	104 000	115 000
VEB 25/NS	25	42	9	0.3	0.15	540	240	510	230	88 000	97 500
VEB 30/NS	30	47	9	0.3	0.15	580	280	540	270	76 000	84 500
VEB 35/NS	35	55	10	0.6	0.3	790	400	750	380	65 000	72 000
VEB 40/NS	40	62	12	0.6	0.3	1 000	530	950	500	57 000	63 000
VEB 45/NS	45	68	12	0.6	0.3	1 050	590	1 000	560	51 000	57 000
VEB 50/NS	50	72	12	0.6	0.3	1 310	740	1 240	700	48 000	52 500
VEB 55/NS	55	80	13	1.0	0.3	1 590	920	1 500	870	43 000	47 500
VEB 60/NS	60	85	13	1.0	0.3	1 670	1 020	1 580	960	40 000	44 000
VEB 65/NS	65	90	13	1.0	0.3	1 690	1 070	1 600	1 010	37 000	41 000
VEB 70/NS	70	100	16	1.0	0.3	2 260	1 400	2 130	1 320	33 500	37 000
VEB 75/NS	75	105	16	1.0	0.3	2 300	1 470	2 170	1 390	31 500	35 000
VEB 80/NS	80	110	16	1.0	0.3	2 340	1 550	2 210	1 460	30 000	33 000
VEB 85/NS	85	120	18	1.1	0.6	3 050	1 990	2 880	1 890	27 500	30 500
VEB 90/NS	90	125	18	1.1	0.6	3 110	2 100	2 940	1 980	26 500	29 000
VEB 95/NS	95	130	18	1.1	0.6	3 170	2 200	2 990	2 080	25 000	27 500
VEB 100/NS	100	140	20	1.1	0.6	3 970	2 730	3 760	2 580	23 500	26 000
VEB 110/NS	110	150	20	1.1	0.6	4 130	2 990	3 900	2 830	21 000	23 500
VEB 120/NS	120	165	22	1.1	0.6	4 860	3 480	4 600	3 300	19 000	21 500

For larger sizes, please contact Application Support.

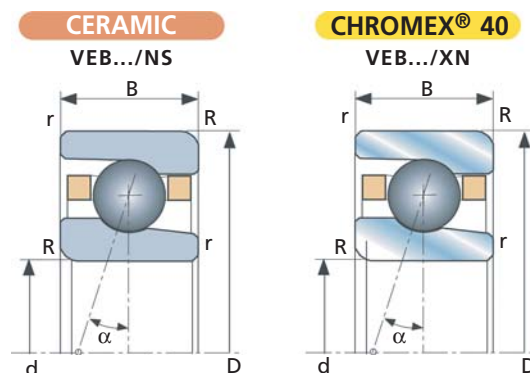

**HB - HB/S ISO 19
HIGH SPEED SERIES**



SNFA	d	D	B	R _{min}	r _{min}	$\alpha = 15^\circ$			$\alpha = 25^\circ$			V _h (ABEC 9)
						C ₃₃	C _E	C _O	C ₃₃	C _E	C _O	
HB 30	30	47	9	0.3	0.15	480	640	370	450	600	350	60 000
HB 35	35	55	10	0.6	0.3	520	690	450	500	665	420	51 000
HB 40	40	62	12	0.6	0.3	550	730	510	520	690	480	45 000
HB 45	45	68	12	0.6	0.3	760	1 010	700	720	960	660	40 500
HB 50	50	72	12	0.6	0.3	780	1 040	760	740	980	710	37 500
HB 55	55	80	13	1.0	0.3	1 020	1 360	990	960	1 280	930	34 000
HB 60	60	85	13	1.0	0.3	1 050	1 400	1 070	990	1 320	1 010	32 000
HB 65	65	90	13	1.0	0.3	1 080	1 440	1 140	1 020	1 360	1 080	30 000
HB 70	70	100	16	1.0	0.3	1 390	1 850	1 490	1 310	1 740	1 410	26 500
HB 75	75	105	16	1.0	0.6	1 430	1 900	1 590	1 350	1 800	1 500	25 000
HB 80	80	110	16	1.0	0.6	1 600	2 130	1 800	1 500	2 000	1 690	23 500
HB 85	85	120	18	1.1	0.6	1 660	2 210	1 970	1 560	2 070	1 860	22 000
HB 90	90	125	18	1.1	0.6	1 810	2 410	2 150	1 700	2 260	2 020	20 500
HB 95	95	130	18	1.1	0.6	1 860	2 470	2 270	1 750	2 330	2 150	19 800
HB 100	100	140	20	1.1	0.6	2 230	2 970	2 720	2 100	2 790	2 570	18 500
HB 110	110	150	20	1.1	0.6	2 650	3 520	3 290	2 500	3 320	3 100	17 000
HB 120	120	165	22	1.1	0.6	2 780	3 700	3 670	2 610	3 470	3 470	15 400

For larger sizes, please contact Application Support.

CE: Extended basic dynamic load rating reflect improvements in material and production processes.
This value is not used by SNFA and is shown only for comparison purposes.

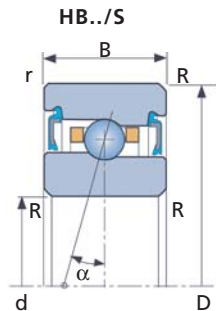
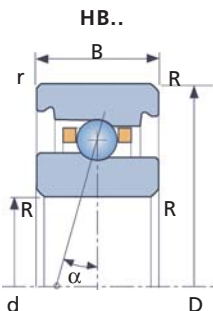

HB/NS - HB/S/NS - HB/S/XN ISO 19 HIGH SPEED SERIES WITH CERAMIC BALLS

SNFA	d	D	B	R _{min}	r _{min}	$\alpha = 15^\circ$			$\alpha = 25^\circ$			CERAMIC	CHROMEX®40
						C ₃₃	C _E	C _O	C ₃₃	C _E	C _O	V _h	V _h
												(ABEC 9)	(ABEC 9)
HB 30/NS	30	47	9	0.3	0.15	480	640	265	450	600	250	72 000	80 500
HB 35/NS	35	55	10	0.6	0.3	520	690	320	500	665	300	61 000	68 500
HB 40/NS	40	62	12	0.6	0.3	550	730	360	520	690	340	54 000	60 500
HB 45/NS	45	68	12	0.6	0.3	760	1 010	500	720	960	470	49 000	54 500
HB 50/NS	50	72	12	0.6	0.3	780	1 040	540	740	980	510	45 000	50 500
HB 55/NS	55	80	13	1.0	0.3	1 020	1 360	710	960	1 280	670	41 000	45 500
HB 60/NS	60	85	13	1.0	0.3	1 050	1 400	760	990	1 320	720	38 500	43 000
HB 65/NS	65	90	13	1.0	0.3	1 080	1 440	820	1 020	1 360	770	36 000	40 500
HB 70/NS	70	100	16	1.0	0.3	1 390	1 850	1 060	1 310	1 740	1 010	32 000	35 500
HB 75/NS	75	105	16	1.0	0.6	1 430	1 900	1 140	1 350	1 800	1 070	30 000	33 500
HB 80/NS	80	110	16	1.0	0.6	1 600	2 130	1 280	1 500	2 000	1 210	28 500	31 500
HB 85/NS	85	120	18	1.1	0.6	1 660	2 210	1 410	1 560	2 070	1 330	26 500	29 500
HB 90/NS	90	125	18	1.1	0.6	1 810	2 410	1 540	1 700	2 260	1 450	24 500	27 500
HB 95/NS	95	130	18	1.1	0.6	1 860	2 470	1 630	1 750	2 330	1 530	24 000	26 500
HB 100/NS	100	140	20	1.1	0.6	2 230	2 970	1 950	2 100	2 790	1 840	22 500	25 000
HB 110/NS	110	150	20	1.1	0.6	2 650	3 520	2 350	2 500	3 320	2 220	20 500	23 000
HB 120/NS	120	165	22	1.1	0.6	2 780	3 700	2 630	2 610	3 470	2 480	18 500	20 500



For larger sizes, please contact Application Support.

CE: Extended basic dynamic load rating reflect improvements in material and production processes. This value is not used by SNFA and is shown only for comparison purposes.

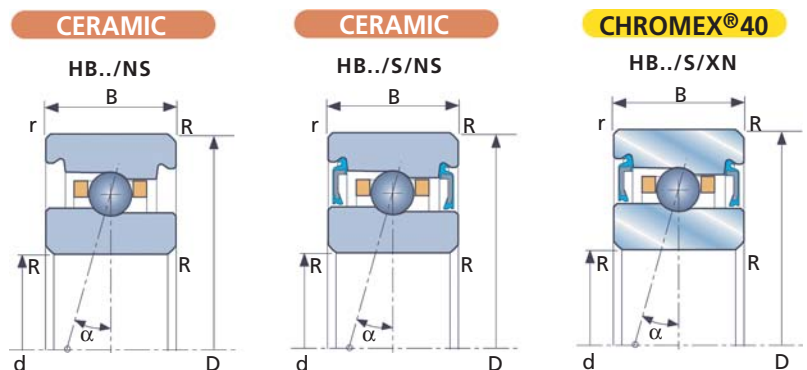

EX ISO 10



SNFA	d	D	B	R _{min}	r _{min}	$\alpha = 15^\circ$		$\alpha = 25^\circ$		V _h (ABEC 9)
						C ₃₃	C ₀	C ₃₃	C ₀	
EX 6	6	17	6	0.3	0.15	160	61	155	59	178 000
EX 7	7	19	6	0.3	0.15	198	77	191	75	157 000
EX 8	8	22	7	0.3	0.15	311	150	300	145	134 000
EX 9	9	24	7	0.3	0.15	341	176	328	169	122 000
EX 10	10	26	8	0.3	0.3	391	223	374	214	112 000
EX 12	12	28	8	0.3	0.15	507	280	488	270	101 000
EX 15	15	32	9	0.3	0.15	576	360	550	350	85 000
EX 17	17	35	10	0.3	0.15	761	480	728	460	76 500
EX 20	20	42	12	0.6	0.3	967	640	924	610	64 500
EX 25	25	47	12	0.6	0.3	1 261	890	1 203	850	55 500
EX 30	30	55	13	1.0	0.3	1 520	1 110	1 450	1 060	47 000
EX 35	35	62	14	1.0	0.3	1 950	1 730	1 846	1 650	35 000
EX 40	40	68	15	1.0	0.3	2 015	1 900	1 885	1 810	31 000
EX 45	45	75	16	1.0	0.3	2 770	2 510	2 630	2 400	28 000
EX 50	50	80	16	1.0	0.3	2 860	2 730	2 700	2 600	25 500
EX 55	55	90	18	1.1	0.6	3 720	3 680	3 520	3 510	23 000
EX 60	60	95	18	1.1	0.6	3 835	3 980	3 630	3 780	21 000
EX 65	65	100	18	1.1	0.6	3 940	4 270	3 740	4 060	20 000
EX 70	70	110	20	1.1	0.6	5 160	5 500	4 880	5 200	18 300
EX 75	75	115	20	1.1	0.6	5 290	5 900	5 000	5 600	17 200
EX 80	80	125	22	1.1	0.6	6 360	7 000	6 010	6 700	15 600
EX 85	85	130	22	1.1	0.6	6 540	7 500	6 180	7 100	15 000
EX 90	90	140	24	1.5	1.0	6 790	8 400	6 400	7 900	13 900
EX 95	95	145	24	1.5	1.0	8 020	9 700	7 590	9 200	13 300
EX 100	100	150	24	1.5	1.0	8 255	10 300	7 760	9 800	12 800
EX 105	105	160	26	2.0	1.0	9 700	11 800	9 150	11 200	11 700
EX 110	110	170	28	2.0	1.0	11 400	13 900	10 780	13 200	11 100
EX 120	120	180	28	2.0	1.0	11 620	14 800	10 970	14 100	10 000
EX 130	130	200	33	2.0	1.0	15 020	19 000	14 180	18 000	9 400
EX 140	140	210	33	2.0	1.0	15 340	20 200	14 480	19 100	8 300
EX 150	150	225	35	2.1	1.0	17 370	23 100	16 390	22 000	7 800
EX 160	160	240	38	2.1	1.0	19 500	26 300	18 400	25 000	7 200
EX 170	170	260	42	2.1	1.0	21 190	29 800	19 990	28 300	6 700
EX 180	180	280	46	2.1	1.0	23 630	35 000	22 290	33 300	6 100
EX 190	190	290	46	2.1	1.0	24 120	36 900	22 750	35 100	5 800
EX 200	200	310	51	2.1	1.0	30 290	46 600	28 600	44 400	5 300
EX 220	220	340	56	3.0	1.5	34 140	55 600	32 240	52 900	4 700
EX 240	240	360	56	3.0	1.5	35 930	62 000	33 930	58 900	4 300

For larger sizes and/or ceramic balls, please contact Application Support.

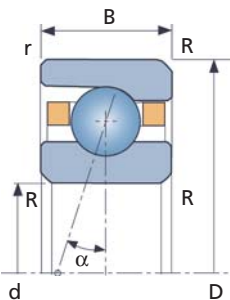

VEX - VEX/S ISO 10 HIGH SPEED SERIES

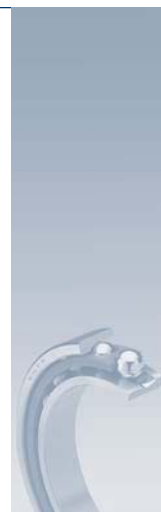

SNFA	d	D	B	R _{min}	r _{min}	$\alpha = 15^\circ$		$\alpha = 25^\circ$		V _h (ABEC 9)
						C ₃₃	C ₀	C ₃₃	C ₀	
VEX 6	6	17	6	0.3	0.15	160	61	--	--	210 000
VEX 7	7	19	6	0.3	0.15	198	77	--	--	190 000
VEX 8	8	22	7	0.3	0.15	240	97	--	--	165 000
VEX 9	9	24	7	0.3	0.15	260	113	--	--	150 000
VEX 10	10	26	8	0.3	0.3	306	143	--	--	140 000
VEX 12	12	28	8	0.3	0.15	390	182	--	--	125 000
VEX 15	15	32	9	0.3	0.15	450	230	--	--	105 000
VEX 17	17	35	10	0.3	0.15	600	310	--	--	95 000
VEX 20	20	42	12	0.6	0.3	760	410	--	--	80 000
VEX 25	25	47	12	0.6	0.3	840	500	800	480	70 000
VEX 30	30	55	13	1.0	0.6	950	630	900	600	60 000
VEX 35	35	62	14	1.0	0.6	1 170	800	1 110	770	50 000
VEX 40	40	68	15	1.0	0.6	1 250	920	1 180	870	45 000
VEX 45	45	75	16	1.0	0.6	1 310	1 040	1 250	980	41 000
VEX 50	50	80	16	1.0	0.6	1 600	1 270	1 510	1 210	38 000
VEX 55	55	90	18	1.1	0.6	1 710	1 480	1 620	1 400	32 000
VEX 60	60	95	18	1.1	0.6	1 740	1 560	1 650	1 480	30 000
VEX 65	65	100	18	1.1	0.6	2 080	1 880	1 970	1 780	28 000
VEX 70	70	110	20	1.1	0.6	2 430	2 230	2 300	2 110	26 000
VEX 75	75	115	20	1.1	0.6	2 670	2 630	2 520	2 490	24 000
VEX 80	80	125	22	1.1	0.6	3 470	3 400	3 290	3 220	21 600
VEX 85	85	130	22	1.1	0.6	3 540	3 560	3 340	3 370	21 000
VEX 90	90	140	24	1.5	1.0	3 670	3 870	3 470	3 660	19 400
VEX 95	95	145	24	1.5	1.0	4 520	4 630	4 270	4 390	18 600
VEX 100	100	150	24	1.5	1.0	4 600	4 840	4 350	4 580	17 900
VEX 110	110	170	28	2.0	1.0	4 830	5 500	4 560	5 200	15 500
VEX 120	120	180	28	2.0	1.0	5 900	6 600	5 600	6 300	14 000

Sealed version available from 20 to 120 mm bore size only.
For larger sizes, please contact Application Support.

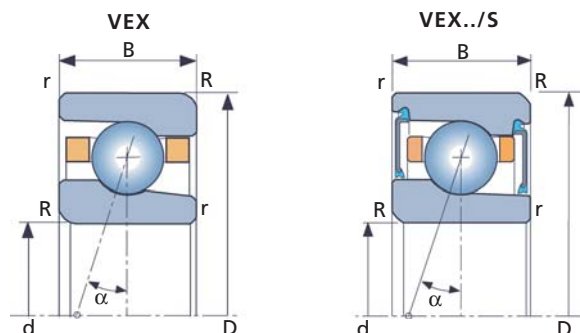

VEX/NS - VEX/S/NS - VEX/S/XN ISO 10
HIGH SPEED SERIES WITH CERAMIC BALLS

SNFA	d	D	B	R _{min}	r _{min}	$\alpha = 15^\circ$		$\alpha = 25^\circ$		CERAMIC	CHROMEX®40
						C33	C0	C33	C0	Vh (ABEC 9)	Vh (ABEC 9)
VEX 6/NS	6	17	6	0.3	0.15	160	44	--	--	252 000	280 000
VEX 7/NS	7	19	6	0.3	0.15	198	55	--	--	228 000	253 000
VEX 8/NS	8	22	7	0.3	0.15	240	69	--	--	198 000	220 000
VEX 9/NS	9	24	7	0.3	0.15	260	81	--	--	180 000	200 000
VEX 10/NS	10	26	8	0.3	0.3	306	103	--	--	168 000	186 000
VEX 12/NS	12	28	8	0.3	0.15	390	131	--	--	150 000	167 000
VEX 15/NS	15	32	9	0.3	0.15	450	166	--	--	126 000	140 000
VEX 17/NS	17	35	10	0.3	0.15	600	220	--	--	114 000	127 000
VEX 20/NS	20	42	12	0.6	0.3	760	290	--	--	96 000	107 000
VEX 25/NS	25	47	12	0.6	0.3	840	360	800	340	84 000	93 000
VEX 30/NS	30	55	13	1.0	0.6	950	450	900	430	72 000	80 000
VEX 35/NS	35	62	14	1.0	0.6	1 170	580	1 110	550	60 000	66 500
VEX 40/NS	40	68	15	1.0	0.6	1 250	660	1 180	630	54 000	60 000
VEX 45/NS	45	75	16	1.0	0.6	1 310	740	1 250	700	50 000	54 500
VEX 50/NS	50	80	16	1.0	0.6	1 600	910	1 510	870	45 500	50 500
VEX 55/NS	55	90	18	1.1	0.6	1 710	1 060	1 620	1 000	38 500	42 500
VEX 60/NS	60	95	18	1.1	0.6	1 740	1 120	1 650	1 060	36 000	40 000
VEX 65/NS	65	100	18	1.1	0.6	2 080	1 340	1 970	1 270	33 500	37 500
VEX 70/NS	70	110	20	1.1	0.6	2 430	1 600	2 300	1 510	31 500	34 500
VEX 75/NS	75	115	20	1.1	0.6	2 670	1 880	2 520	1 780	29 000	32 000
VEX 80/NS	80	125	22	1.1	0.6	3 470	2 430	3 290	2 300	26 000	28 500
VEX 85/NS	85	130	22	1.1	0.6	3 540	2 550	3 340	2 410	25 500	28 000
VEX 90/NS	90	140	24	1.5	1.0	3 670	2 770	3 470	2 620	23 500	26 000
VEX 95/NS	95	145	24	1.5	1.0	4 520	3 320	4 270	3 140	22 500	24 500
VEX 100/NS	100	150	24	1.5	1.0	4 600	3 470	4 350	3 280	21 500	24 000
VEX 110/NS	110	170	28	2.0	1.0	4 830	3 910	4 560	3 700	18 500	20 500
VEX 120/NS	120	180	28	2.0	1.0	5 900	4 750	5 600	4 500	17 000	18 600

Sealed version available from 20 to 120 mm bore size only.
For larger sizes, please contact Application Support.

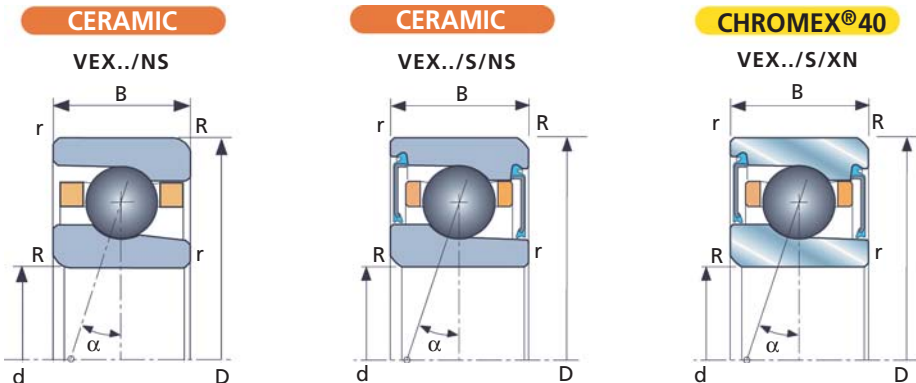

HX - HX/S ISO 10 HIGH SPEED SERIES



SNFA	d	D	B	R _{min}	r _{min}	$\alpha = 15^\circ$			$\alpha = 25^\circ$			V _h (ABEC 9)
						C ₃₃	C _E	C _O	C ₃₃	C _E	C _O	
HX 30	30	55	13	1.0	0.6	660	880	500	620	825	470	55 000
HX 35	35	62	14	1.0	0.6	700	930	580	660	880	550	48 000
HX 40	40	68	15	1.0	0.6	750	1 000	670	710	940	630	43 000
HX 45	45	75	16	1.0	0.6	970	1 290	870	920	1220	820	39 000
HX 50	50	80	16	1.0	0.6	1 010	1 340	950	950	1 260	900	36 000
HX 55	55	90	18	1.1	0.6	1 410	1 870	1 330	1 340	1 780	1 260	32 000
HX 60	60	95	18	1.1	0.6	1 470	1 950	1 450	1 380	1 830	1 370	29 000
HX 65	65	100	18	1.1	0.6	1 510	2 010	1 560	1 430	1 900	1 470	27 000
HX 70	70	110	20	1.1	0.6	1 970	2 620	2 000	1 860	2 470	1 890	25 000

For larger sizes, please contact Application Support.

CE: Extended basic dynamic load rating reflect improvements in material and production processes.
This value is not used by SNFA and is shown only for comparison purposes.

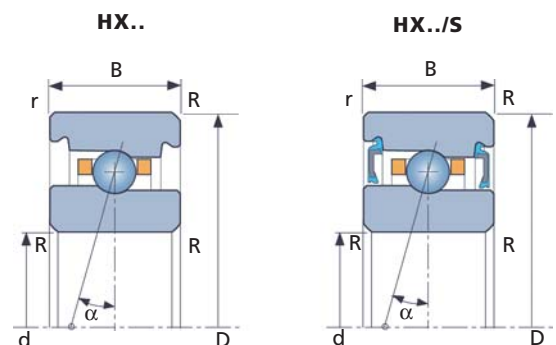

HX/NS - HX/S/NS - HX/S/XN ISO 10

HIGH SPEED SERIES WITH CERAMIC BALLS



SNFA	d	D	B	R _{min}	r _{min}	$\alpha = 15^\circ$			$\alpha = 25^\circ$			CERAMIC	CHROMEX [®] 40
						C ₃₃	C _E	C _O	C ₃₃	C _E	C _O	Vh	Vh
												(ABEC 9)	(ABEC 9)
HX 30/NS	30	55	13	1.0	0.6	660	880	360	620	825	340	66 000	74 000
HX 35/NS	35	62	14	1.0	0.6	700	930	420	660	880	390	58 000	64 500
HX 40/NS	40	68	15	1.0	0.6	750	1 000	480	710	940	450	52 000	58 000
HX 45/NS	45	75	16	1.0	0.6	970	1 290	620	920	1 220	590	47 000	52 500
HX 50/NS	50	80	16	1.0	0.6	1 010	1 340	680	950	1 260	640	43 500	48 500
HX 55/NS	55	90	18	1.1	0.6	1 410	1 870	950	1 340	1 780	900	38 500	43 000
HX 60/NS	60	95	18	1.1	0.6	1 470	1 950	1 030	1 380	1 830	980	35 000	39 000
HX 65/NS	65	100	18	1.1	0.6	1 510	2 010	1 120	1 430	1 900	1 050	32 500	36 500
HX 70/NS	70	110	20	1.1	0.6	1 970	2 620	1 430	1 860	2 470	1 350	30 000	33 500

For larger sizes, please contact Application Support.

CE: Extended basic dynamic load rating reflect improvements in material and production processes. This value is not used by SNFA and is shown only for comparison purposes.

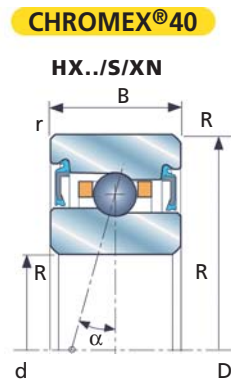
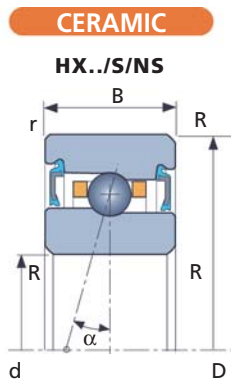
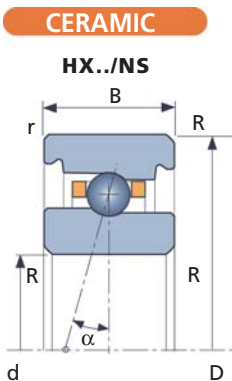

E 200 ISO 02



SNFA	d	D	B	R _{min}	r _{min}	$\alpha = 15^\circ$		$\alpha = 25^\circ$		V _h (ABEC 9)
						C ₃₃	C ₀	C ₃₃	C ₀	
E 207	7	22	7	0.3	0.15	365	194	350	187	121 000
E 208	8	24	8	0.3	0.15	455	230	440	220	109 500
E 209	9	26	8	0.3	0.15	550	320	530	300	100 000
E 210	10	30	9	0.6	0.3	655	370	640	360	87 000
E 212	12	32	10	0.6	0.3	720	440	695	420	79 500
E 215	15	35	11	0.6	0.3	915	570	885	550	69 500
E 217	17	40	12	0.6	0.3	1 140	720	1 090	700	61 000
E 220	20	47	14	1.0	0.6	1 315	940	1 260	910	51 500
E 225	25	52	15	1.0	0.6	1 720	1 290	1 640	1 230	44 500
E 230	30	62	16	1.0	0.6	2 350	1 850	2 250	1 770	37 000
E 235	35	72	17	1.1	0.6	2 600	2 270	2 480	2 170	31 500
E 240	40	80	18	1.1	0.6	3 430	3 050	3 280	2 920	28 500
E 245	45	85	19	1.1	0.6	3 590	3 350	3 410	3 200	25 500
E 250	50	90	20	1.1	0.6	4 370	4 010	4 150	3 830	24 000
E 255	55	100	21	1.5	1.0	5 560	5 000	5 300	4 830	21 000
E 260	60	110	22	1.5	1.0	5 770	5 600	5 490	5 300	19 400
E 265	65	120	23	1.5	1.0	6 800	6 800	6 490	6 500	17 800
E 270	70	125	24	1.5	1.0	7 085	7 400	6 730	7 100	16 700
E 275	75	130	25	1.5	1.0	7 345	8 000	6 980	7 600	15 600
E 280	80	140	26	2.0	1.0	8 960	9 600	8 490	9 100	14 400
E 285	85	150	28	2.0	1.0	9 830	10 700	9 330	10 200	13 300
E 290	90	160	30	2.0	1.0	12 490	13 200	11 920	12 700	12 800
E 295	95	170	32	2.1	1.1	11 780	13 400	11 190	12 800	11 700
E 200/100	100	180	34	2.1	1.1	14 740	16 400	14 050	15 700	11 100
E 200/105	105	190	36	2.1	1.1	17 030	18 600	16 190	17 800	10 300
E 200/110	110	200	38	2.1	1.1	17 670	20 100	16 760	19 100	10 000
E 200/120	120	215	40	2.1	1.1	17 900	21 700	16 900	20 700	9 100
E 200/130	130	230	40	3.0	1.5	20 400	25 600	19 400	24 400	8 300
E 200/140	140	250	42	3.0	1.5	23 140	30 400	21 900	29 000	7 400

For larger sizes and/or ceramic balls, please contact Application Support.

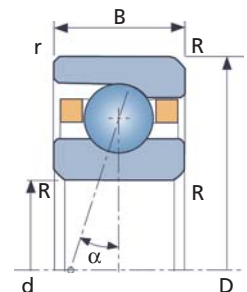

BS 200 - BS 200/S ISO 02



SNFA	d	D	B	R _{min}	r _{min}	C ₃₃	C ₀	V _h (ABEC 7)	M
BS 212	12	32	10	0.6	0.6	945	1 440	23 000	0.037
BS 215	15	35	11	0.6	0.6	1 025	1 760	20 000	0.047
BS 217*	17	40	12	0.6	0.6	1 365	2 380	17 700	0.069
BS 220	20	47	14	1.0	0.6	1 820	3 380	15 200	0.111
BS 225	25	52	15	1.0	0.6	2 000	4 240	13 200	0.138
BS 230	30	62	16	1.0	0.6	2 460	5 400	11 100	0.220
BS 235	35	72	17	1.1	0.6	3 055	7 100	9 600	0.320
BS 240	40	80	18	1.1	0.6	3 745	9 100	8 600	0.400
BS 245	45	85	19	1.1	0.6	3 785	9 700	7 800	0.460
BS 250	50	90	20	1.1	0.6	3 835	10 300	7 400	0.520
BS 260	60	110	22	1.5	0.6	5 805	15 800	6 100	0.860
BS 275	75	130	25	1.5	0.6	6 400	20 200	4 800	1.500

For sealed version, please consult Application Support.

BS (Special)

SNFA	d	D	B	R _{min}	r _{min}	C ₃₃	C ₀	V _h (ABEC 7)	M
BS 17/47	17	47	15	1.0	1.0	1 820	3 380	15 200	0.138
BS 20/47	20	47	15	1.0	1.0	1 820	3 380	15 200	0.128
BS 25/62	25	62	15	1.0	1.0	2 460	5 400	11 100	0.242
BS 30/62	30	62	15	1.0	1.0	2 460	5 400	11 100	0.217
BS 35/72	35	72	15	1.1	1.1	3 055	7 100	9 600	0.282

* Available on request.

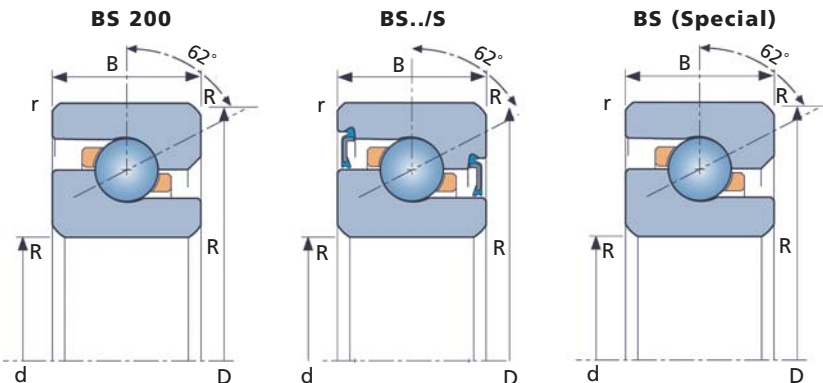

BSDU BALL SCREW BEARING CARTRIDGE UNITS



Shaft Dia. mm	SNFA	Dimensions without tolerances: ± 0.13 mm													C ₃₃	C _o	C _r	R _a	Axial Runout μ m	M	Vg*
		A	B	C	D	E	F	G	H	I	J	K	L	M							
20	BSDU 220 DD 230	20.000	26.0	60.000	90.0	32.0	13.0	44.260	47.0	36.0	64.0	32.0	6.6	76.0	1820	3380	10	72	2.5	1.1	3900
	BSDU 220 FF 230	19.996		59.987				43.240													
25	BSDU 225 DD 280	25.000	34.0	80.000	120.0	32.0	15.0	50.260	52.0	36.0	88.0	44.0	9.2	102.0	2000	4240	12	88	2.5	2.3	3400
	BSDU 225 FF 280	24.996		79.987				49.240													
30	BSDU 230 DD 360	30.000	41.0	80.000	120.0	32.0	15.0	50.260	52.0	50.0	88.0	44.0	9.2	102.0	2460	5400	19	100	2.5	2.3	2850
	BSDU 230 FF 360	29.996		79.987				49.240													
35	BSDU 235 DD 475	35.000	46.0	90.000	130.0	32.0	15.0	50.260	52.0	60.0	98.0	49.0	9.2	113.0	3055	7100	33	118	2.5	3.2	2500
	BSDU 235 FF 475	34.995		89.987				49.240													
40	BSDU 240 DD 600	40.000	55.0	124.000	165.0	43.5	17.0	64.260	66.0	66.0	128.0	64.0	11.4	146.0	3745	9100	41	137	2.5	6.1	2200
	BSDU 240 FF 600	39.995		123.982				63.240													
45	BSDU 245 DD 640	45.000	66.0	124.000	165.0	43.5	17.0	64.260	66.0	76.0	128.0	64.0	11.4	146.0	3785	9700	47	145	2.5	5.9	2000
	BSDU 245 FF 640	44.995		123.982				63.240													
50	BSDU 250 DD 680	50.000	66.0	124.000	165.0	43.5	17.0	64.260	66.0	76.0	128.0	64.0	11.4	146.0	3835	10300	53	153	2.5	5.7	1900
	BSDU 250 FF 680	49.995		123.982				63.240													

Final number in reference is the bearing set preload value in daN. Special preload values are available on request.

* Max speed with grease (rpm). Cartridge units will be supplied greased with high quality synthetic grease.

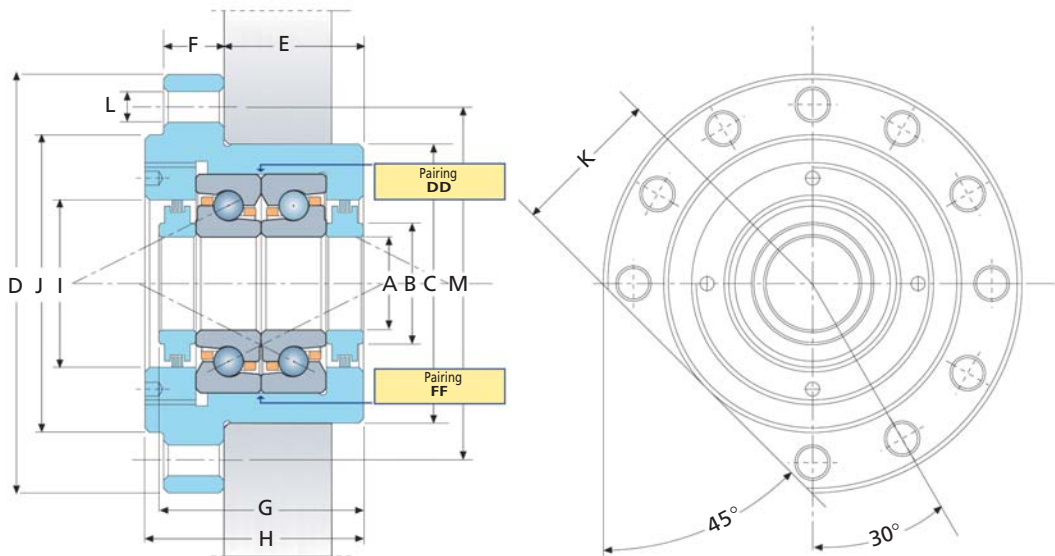

BSQU

BALL SCREW BEARING CARTRIDGE UNITS



Shaft Dia. mm	SNFA	Dimensions without tolerances: ± 0.13 mm												C ₃₃	C _o	C _r	R _a	Axial Runout μm	M	Vg*	
		A	B	C	D	E	F	G	H	I	J	K	L								M
20	BSQU 220 TDT 460	20.000	26.0	60.000	90.0	32.0	13.0	74.260	77.0	36.0	64.0	32.0	6.6	76.0	2950	6760	20	144	2.5	1.7	3250
	BSQU 220 TFT 460	19.996		59.987				72.740													
25	BSQU 225 TDT 560	25.000	34.0	80.000	120.0	32.0	15.0	80.260	82.0	40.0	88.0	44.0	9.2	102.0	3240	8480	23	176	2.5	3.5	2850
	BSQU 225 TFT 560	24.996		79.987				78.740													
30	BSQU 230 TDT 720	30.000	41.0	80.000	120.0	32.0	15.0	82.260	84.0	50.0	88.0	44.0	9.2	102.0	3985	10800	37	200	2.5	3.5	2400
	BSQU 230 TFT 720	29.996		79.987				80.740													
35	BSQU 235 TDT 950	35.000	46.0	90.000	130.0	32.0	15.0	84.260	86.0	60.0	98.0	49.0	9.2	113.0	4950	14200	67	236	2.5	4.6	2100
	BSQU 235 TFT 950	34.995		89.987				82.740													
40	BSQU 240 TDT 1200	40.000	55.0	124.000	165.0	43.5	17.0	104.260	106.0	66.0	128.0	64.0	11.4	146.0	6070	18200	81	274	2.5	9.7	1900
	BSQU 240 TFT 1200	39.995		123.982				102.740													
45	BSQU 245 TDT 1280	45.000	66.0	124.000	165.0	43.5	17.0	104.260	106.0	76.0	128.0	64.0	11.4	146.0	6130	19400	92	290	2.5	9.4	1700
	BSQU 245 TFT 1280	44.995		123.982				102.740													
50	BSQU 250 TDT 1360	50.000	66.0	124.000	165.0	43.5	17.0	104.260	106.0	76.0	128.0	64.0	11.4	146.0	6210	20600	106	306	2.5	9.1	1550
	BSQU 250 TFT 1360	49.995		123.982				102.740													

Final number in reference is the bearing set preload value in daN. Special preload values are available on request.

* Max speed with grease (rpm). Cartridge units will be supplied greased with high quality synthetic grease.

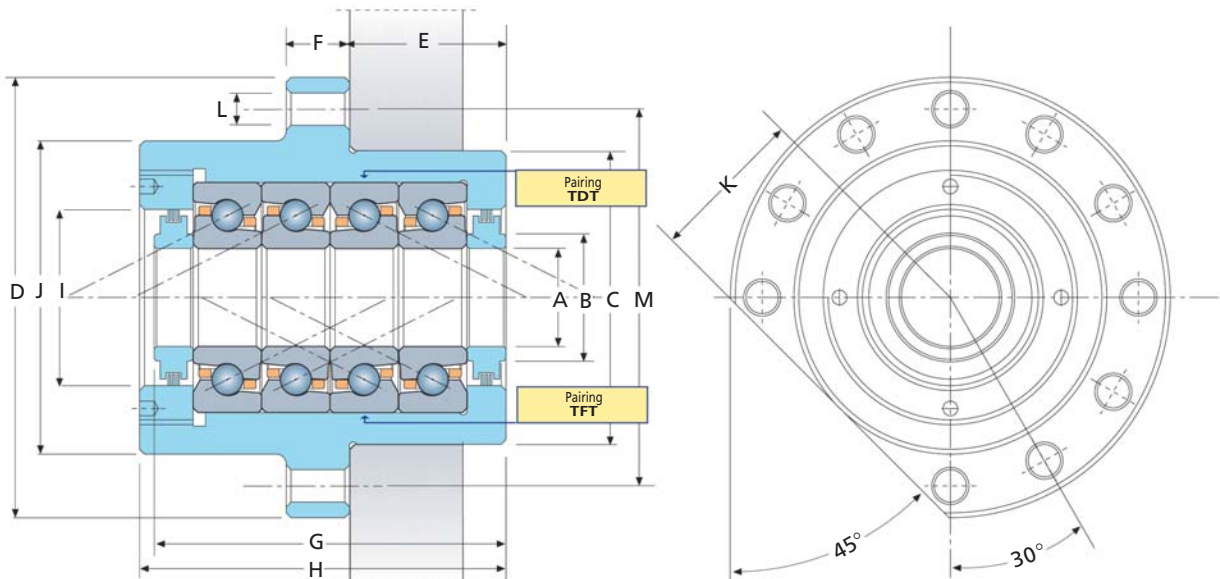

BSQU/1

BALL SCREW BEARING CARTRIDGE UNITS



Shaft Dia. mm	SNFA	Dimensions without tolerances: ± 0.13 mm														C ₃₃	C ₀	C _r	R _a	Axial Runout μm	M	Vg*	
		A	B	C	D	E	F	G	H	I	J	K	L	M	N								P
30	BSQU 230/1 TDT 720	30.000	41.0	88.000	120.0	3.5	15.0	86.260	86.0	50.0	88.0	45.0	9.2	102.0	35.0	M8x1.25	3985	10800	37	200	2.5	3.7	2400
	BSQU 230/1 TFT 720	29.996		87.985				84.740															
40	BSQU 240/1 TDT 1200	40.000	55.0	128.000	165.0	4.0	24.0	106.260	106.0	66.0	128.0	65.5	11.4	146.0	35.0	M10x1.5	6070	18200	81	274	2.5	10.0	1900
	BSQU 240/1 TFT 1200	39.995		127.982				104.740															
50	BSQU 250/1 TDT 1360	50.000	66.0	128.000	165.0	4.0	24.0	106.260	106.0	76.0	128.0	65.5	11.4	146.0	35.0	M10x1.5	6210	20600	106	306	2.5	9.3	1550
	BSQU 250/1 TFT 1360	49.995		127.982				104.740															
60	BSQU 260/1 TDT 2080	60.000	80.0	145.000	185.0	20.5	25.0	114.260	114.0	92.0	145.0	74.5	11.4	165.0		M10x1.5	9400	31600	176	370	2.5	12.3	1300
	BSQU 260/1 TFT 2080	59.993		144.982				112.740															

Final number in reference is the bearing set preload value in daN. Special preload values are available on request.

* Max speed with grease (rpm). Cartridge units will be supplied greased with high quality synthetic grease.

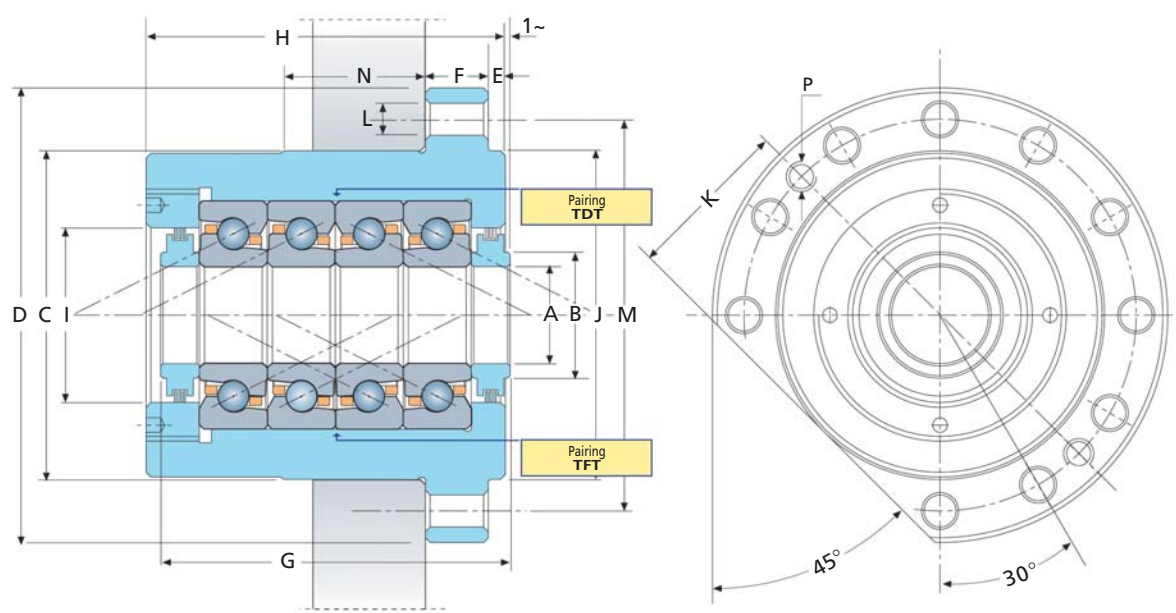

Notes

Large dotted grid area for notes.



THE SNFA GROUP

Internet: www.snfa.com
E-mail: info@snfa.com

SNFA SA

Zone Industrielle No. 2, Batterie 900
59309 Valenciennes Cedex
FRANCE

Tel. +33 (0)3 27 23 52 12
Fax. +33 (0)3 27 23 52 97

SNFA Bearings Ltd.

Charfield Wotton-under-Edge
Gloucestershire, GL12 8SP
ENGLAND

Tel: +44 (0)1453 843501
Fax: +44 (0)1453 842577

SNFA G.m.b.H.

Ringstrasse 134 - D
70839 Gerlingen
GERMANY

Tel: +49 (0)7156 20450
Fax: +49 (0)7156 204550

SNFA S.A., Fribourg

Route du Platy 5a, P.O. Box 34
CH-1752 Villars-Sur-Glâne 1
SWITZERLAND

Tel: +41 (0)26 4020766
Fax: +41 (0)26 4020614

SOMECAT S.p.A.

Via Savonera - Druento 15
10044 Pianezza (Torino)
ITALY

Tel: +39 (0)11 994 1407
Fax: +39 (0)11 984 5804



*** Please note:** The contents of this catalogue are the exclusive property of SNFA. All information, images, tables and abstracts have been carefully edited and are considered to be accurate at the time of issue. However, no responsibility for possible errors or omissions can be assumed. This catalogue implies the existence of no constraint whatsoever as to the products illustrated. SNFA reserves the right to change without notice. Used with permission in Canada by RotoPrecision Inc. Duplication in whole or in part without written consent is prohibited. © SNFA and RotoPrecision Inc.



For the Sales Office or
Authorized Distributor nearest you,
please contact us at:

TORONTO
1-800-387-7494

MONTREAL
1-800-495-4395

VANCOUVER
1-800-680-7686

APPLICATION SUPPORT
1-888-712-3400

ON THE INTERNET
www.rotoprecision.ca

///RotoPRECISION Inc.

Authorized Distributor