



Unibal®
The key to success!

	Page
Our products	4
Standards	4
Derivatives	4
Specialities	4
Railways	4
Aerospace	4
Definitions	5
Dimensional standards	5
Field of application	5
Standard programme	6
Description	6
Series	6
Slip	7
Construction	7
Options and derivatives from standard	7
Calculations	9
Static loading	9
Axial static loading	9
Checking the application	10
Calculating specific pressure	10
Calculating contact slip velocity	11
PV factor	11
Calculating life	11
Determining calculation coefficients	12
Examples of dynamic calculations	14
Materials	9
Uniflon® Type E	16
Composition	16
Features	16
Alternatives	16
Lubrication	17
Lubrication and maintenance	17
standard lubrication	17
Special lubrication	17
Protection, seal	18
Neoprene protection	18
Exécution 2RS	18

Play, rotation torque, tilt torque	19
Play.....	19
Torque	19
Tilt angle	20
Montage	21
Instructions de montage.....	21
Materials	21
Rod-end bearings with maintenance	22
Standard series	SM/SF SMG/SFG.....22
Special Thread Series	SMG/SFG..20.....24
High Tensile Series	SM/SF..40 SMG/SFG..40.....26
Stainless Steel Series	SM/SF..45 SMG/SFG..45.....28
Competition Series	SMM..50/51 SMGM..50/51/52.....30
Rod-end bearings maintenance-free	32
Standard series	SME/SFE.....32
High Tensile Series	SME/SFE..40.....34
Stainless Steel Series	SME/SFE..45.....36
Competition Series	SMEM..50/51/52.....38
Spherical bearings with maintenance	40
Standard series	SS.....40
Stainless Steel Series	SS..45.....41
Standard series	SSA.....41
Stainless Steel Series	SSA..45.....42
Competition Series	SSA..50.....43
Standard series	SSE.....44
Stainless Steel Series	SSE..45.....45
Competition Series	SSE..50.....46
Application data to be provided to calculate life	48

Standards



In its standard programme, Schaublin offers a huge range of spherical bearings. The item reference gives the identity of the spherical bearing.

- The shape
- The nature of the slip contact
- The series

Our standard rod-end bearings comply with the dimensions of the ISO 12240-4 series K standard, so as to allow total interchangeability.

Derivatives



In order to supplement the standard programme, Schaublin makes spherical bearings to your requirements.

- Special thread pitch
- Specific thread length
- High mechanical performance steel mounts
- Specific slip surfaces

Specialities

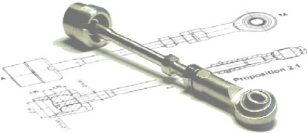

Schaublin is there to help with any special development in accordance with your specifications.

- Specific dimensions for each application
- Processing and choice of materials suited to conditions in use

Technical discussions are held to give you the most suitable solution.

Railways

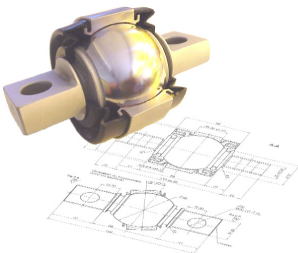

Long experience in the railway sphere has made Schaublin a benchmark. Spherical bearings are developed to the customer's own particular specification. Schaublin is certified by SNCF Railway Quality Assurance part II (AQF2)

Aerospace



Complete bearing assemblies created.

Spherical bearings manufactured to international aerospace standards.

- All our components are certified
- Production of standards
- One-off specialities produced to the customer's specification.

Schaublin's quality system is AECMA-EASE certified.

Dimensional standards

ISO 12240-4

The international standard sets the dimensions of rods with spherical bearing assembled. It also specifies tolerances relative to the dimensions.

The diameter of the head d_2 is sized at the lower value of the standard, which gives our rod-end bearings minimal size and weight, thus ensuring total interchangeability with any other rod-end bearing meeting the standard.

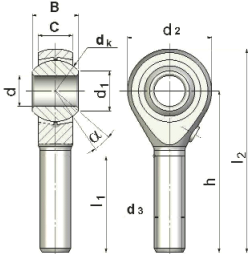

European and American aerospace standards

Schaublin SA manufactures and distributes spherical bearings and self-lubricated bushes to the following standards:

EN2584, EN2585, EN3048, EN4613, EN4614, EN2022, EN2023, EN2501, AS14101, AS14102, AS14103, AS14104, AS81935/1, AS81935/2, AS81820/1, AS81820/2, AS81820/3, AS81820/4, AS81934/1, AS81934/2, AS81936/1, AS81936/2, AS21154, AS21155, AS21240, AS21241, AS21242, AS21243, EN2285, EN2286, EN2287, EN2288

Field of application



Rod-end and spherical bearings are designed to be used between the fixed or moving components of mechanical assemblies.

- Assembly, alignment
- Transmission of movements, loadings
- Joints

Spherical bearings are designed for applications with movements at low rotation speeds. They are sized according to the loading and operating cycle required.

Description

SME 12.40

SCHAUBLIN	
Shape	M: Rod-end bearing Male ML: Rod-end bearing Male, left-hand thread F: Rod-end bearing Female FL: Rod-end bearing Female, LH thread S: Spherical (to be fitted in a mount)
Type of Slip	_: Steel / Bronze, without Lubricator G: Steel / Bronze, with Lubricator A: Steel / Steel E: Steel / Uniflon® (self-lubricating fabric)
Size	Nominal size
Series	_: Standard .20: Special thread .40: High tensile .45: Stainless steel .50: Competition
(Derivatives)	.30: Made according to Male spherical bearing drawing



Series

	Mechanical industry	Food and vulnerable products	Sport, competition	Benefit	Special features
-	•	•	•	Excellent resistance to impacts, static loadings and vibrations	General mechanical standard
.40	•	•	••	High static and dynamic loadings	Body of rod made from high tensile steel
.45	•	•••		Use in a corrosive environment	Stainless steel
.50	•		•••	Very high static and dynamic loadings, at low speed	Magnetic fault inspection



Slip

Type	Friction	Maintenance	Benefit	Special features
G	Steel / Bronze Steel / Steel (Series 50)	Regular lubrication	Good radial and axial strength	The lubricator is available on male and female rods from size 8 Working temperature 150°C max (special lubrication)
A	Steel / Steel	Regular lubrication	Excellent impact resistance Excellent radial strength	Version not available on rod-end bearings Without lubricator Working temperature 300°C max (special lubrication)
E	Steel / Uniflon® E	Maintenance-free, self-lubricating fabric	Excellent impact resistance Excellent radial strength	The Uniflon® E self-lubricating fabric bonded into the outer bush ensures optimal life Working temperature 120°C max

Construction

	Series	Inner bush	Outer bush	Benefit	Special features
SM.. SMG.. SF.. SFG..	-	Chrome steel	Bronze spacers	The design with spacers provides very good axial strength	
	.40	Stainless steel	Stainless steel spacers		
	.45	Chrome steel	Stainless steel spacers		
SS..	-	Chrome steel	Bronze spacers		
	.45	Stainless steel			
SSA..	-	Chrome steel	Cage steel	The steel construction guarantees very substantial radial strength	The steel/steel construction and special lubrication enables a working temperature of 300°C
	.45	Stainless steel	Cage stainless steel		
	.50	Chrome steel	Cage steel		
SME.. SFE..	-	Chrome steel	Uniflon® E self-lubricating fabric	Uniflon® E PTFE fabric bonded into the outer bush improves slip and increases life. Requires no maintenance	The damping properties of Uniflon® E self-lubricating fabric are ideal for applications with vibration
	.40	Stainless steel			
	.45	Chrome steel			
SSE..	-	Chrome steel	Uniflon® E self-lubricating fabric		
	.45	Stainless steel			
	.50	Chrome steel			

Options and derivatives from standard*

Options	Special thread	Cetop...
	Special lubrication	For life, high pressure, high temperature
	Specific torque	
	Specific play	
	Material traceability	
	Magnetic fault inspection	Standard on .50 grade
	Neoprene protection	
Derivatives	Special materials	
	Length threaded special	
	Specific head diameter	
	Inner bush with lugs	
	Sealed spherical bearing	

* Contact us for any special requirements

*For any special requirements
or other dimensions,
please ask*

Static loading

The **basic static loading** C_0 is given in the tables of dimensions. For a rod-end bearing, it is limited by the strength of the mount.

The values given in the Unibal standard programme tables are calculated from the elastic limit of the mount material (C_{se}) taking a safety factor into account:

$$C_0 = \frac{C_{se}}{1.25}$$

In the case of a spherical bearing, the basic static loading C_0 is calculated using the following formula:

$$C_0 = d_k \times C \times 0.85 \times X$$

d_k : diameter of the inner bush sphere (mm)

C : width of the mount (mm)

X : Stress admissible by the material ($\text{daN} \cdot \text{mm}^{-2}$)

Fatigue resistance: Please note that values given in the tables of dimensions are for occasional static loadings. Ask us where fatigue resistance is required.

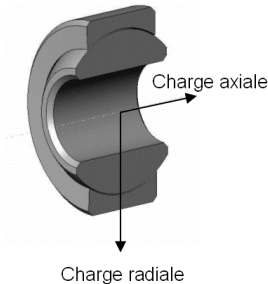

Axial static loading

The following table gives the values for the axial static loading not to be exceeded for spherical and rod-end bearings.

Standard series, .40, .45, .50, .51 and .52	Limit axial static loadings F_a adm.
SME/SFE/SMEM/SSE	8% C_0
SM/SF SMG/SFG SS/SSA	20% C_0

C_0 : Basic static loading (see tables of dimensions pages 24 to 47)

In the case of rod-end bearings, it must also be ensured that the thread is properly located so as to prevent any risk of buckling or stripping of the rod-end bearing shank.

In the case of spherical bearings (SS, SSA, SSE), attention must be paid to maintaining the cage axially (see assembly instructions chapter, page 23)

Checking the application

Proceed as follows to check the choice of a spherical bearing:

- Calculate and check whether the pressure is within the allowable limits
- Calculate and check whether the velocity is within the allowable limits
- Calculate the PV factor (Pressure x Velocity) and check the allowable limit

Series	Slip contact		Max. allowable pressure (daN · mm ⁻²)	Max. allowable velocity (m · min ⁻¹)	Maximum allowable PV
	Int. bush	Ext. bush			
-	Steel	Bronze	5	5	3.5
		Steel	10	4	3.5
		Uniflon® E	15	4	4.5
.40	Steel	Bronze	5	2.5	3
		Uniflon® E	15	4	4.5
.45	Stainless steel	Bronze	5	4.5	3
		Stainless steel	10	4.5	3.5
		Uniflon® E	15	4	4
.50	Steel	Stainless steel	10	2.5	4.5
		Uniflon® E	15	4	4.5

Calculating specific pressure

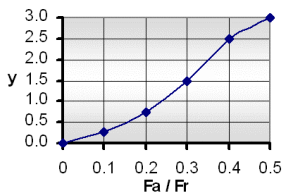

Coefficient of axial loading **y** and equivalent dynamic loading:

- Our spherical bearings are designed to withstand radial loadings (F_r). But the combination with an axial loading (F_a) is sometimes inevitable and spherical bearings are able to accommodate it to a certain extent. So the equivalent dynamic loading F must be calculated taking into account a correction factor y for that axial loading. The table opposite gives the value of y for different F_a / F_r ratios.

$$F = F_r + (y \times F_a) \quad \text{Normal case: } F = F_r$$

Checking the average pressure according to the force exercised on the friction surface.

$$P = \frac{F}{d_K \times C \times 0.85}$$

P: pressure (daN·mm⁻²)

F: total dynamic loading (daN)

F_r : radial dynamic loading (daN)

F_a : axial dynamic loading (daN)

d_K : diameter of the inner sphere bush (mm)

C: width of the mount or cage (mm)

Calculating the slip velocity on contact

Checking the maximum friction velocity between the inner bush and outer bush.

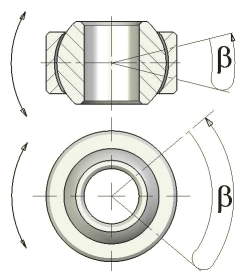

$$V = \frac{d_K \times \beta \times f}{114'600}$$

- V: velocity (m.min⁻¹)
 d_K: diameter of the inner bush sphere (mm)
 β: angle of oscillation complete (degrees)
 f: frequency of oscillation (Hz)

PV factor

$$PV = P \times V$$

- P: pressure (daN.mm⁻²) V: velocity (m.min⁻¹)

Calculating life

If your application requires the play or torque of the spherical bearing to be controlled throughout its life, please ask us.

$$D_h = \frac{C_1 \cdot C_2 \cdot C_3 \cdot C_4 \cdot C_5 \cdot C_6 \cdot C_7 \cdot C_8 \cdot X \cdot C \cdot K \cdot 10^7}{F \cdot \beta \cdot f}$$

$$D = \frac{C_1 \cdot C_2 \cdot C_3 \cdot C_4 \cdot C_5 \cdot C_6 \cdot C_7 \cdot C_8 \cdot X \cdot C \cdot K \cdot 10^7}{F \cdot \beta \cdot 0.0167}$$

- D_h : life in hours (h)
 D : life (number of oscillations or complete rotations)
 C : Width of the cage or rod (P24 to 47)
 K : Constant given by the table opposite
 F : radial dynamic loading (daN)
 β : angular distance run per cycle (degrees)
 f : frequency of oscillations (osc/min)
 c1 : coefficient of pressure (p.12)
 c2 : coefficient of velocity (p.12)
 c3 : coefficient of angle (p.13)
 c4 : coefficient of strain (p.13)
 c5 : coefficient of alternate loadings (p.13)
 c6 : coefficient of maintenance (p.13)
 c7 : coefficient of temperature (p.13)
 c8 : coefficient of vibration (c8 = 1 or 0.8)
 If parts have to withstand vibrations greater than 60 vibr./min., use a coefficient c8 of 0.8.
 X : Coefficient of safety (min.=0.7, max.=1)
 According to your estimate of external influences, unknowns and their importance from the functional point of view (abrasive environment, corrosion, etc.), use a coefficient X of 0.7 to 1.0

Type	Constant K
SMG, SFG	85
SMG..20, SFG..20	85
SMG..40, SFG..40	70
SMG..45, SFG..45	80
SMGM..50 / 51 / 52	105
SME, SFE	105
SME..40, SFE..40	100
SME..45, SFE..45	110
SMEM..50 / 51 / 52	85
SS	70
SS..45	75
SSA	70
SSA..45	80
SSA..50	105
SSE	100
SSE..45	110
SSE..50	110

Determining calculation coefficients

The life of a spherical bearing or rod is the maximum number of running hours or oscillations before play appears that does not allow the spherical bearing to fulfil its function.

The life is a function of the dynamic strain and of the various parameters of the application.

- Pressure
- Velocity (angle and frequency of oscillations)
- Strain (continuous, pulsating, alternate loadings)
- Temperature
- Vibrations

Calculation formulas, worked out from trials conducted on our test benches, enable you to determine the life in accordance with your application.

In the case of a pulsating or alternate loading, the value to use for F is the absolute maximum value reached.

To determine it correctly, all possible data should be taken into consideration – no unknowns should remain that could invalidate the result.

For specific uses in a particular environment (corrosion, vibration, aggressive ambient environment, abrasive dust, etc.), please ask us.

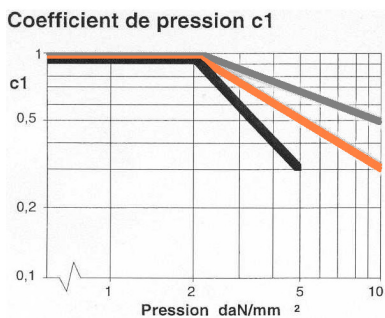

<p>Slip Steel / bronze</p> <p>SMG, SFG SMG..40, SFG..40 SMG..45, SFG..45</p> <p>SS SS..45</p>
--

<p>Slip Steel / Steel</p> <p>SMGM..50 SMGM..51 SMGM..52</p> <p>SSA SSA..45 SSA..50</p>

<p>Slip Steel / Uniflon®</p> <p>SME, SFE SME..40, SFE..40 SME..45, SFE..45 SMEM..50 / 51 / 52</p> <p>SSE SSE..45 SSE..50</p>

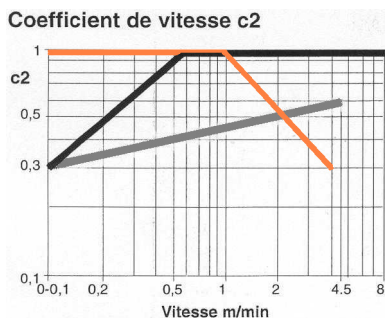

<p>Slip Steel / bronze</p> <p>SMG, SFG SMG..40, SFG..40 SMG..45, SFG..45</p> <p>SS SS..45</p>
--

<p>Slip Steel / Steel</p> <p>SMGM..50 SMGM..51 SMGM..52</p> <p>SSA SSA..45 SSA..50</p>

<p>Slip Steel / Uniflon®</p> <p>SME, SFE SME..40, SFE..40 SME..45, SFE..45 SMEM..50 / 51 / 52</p> <p>SSE SSE..45 SSE..50</p>

Coefficient d'angle c3

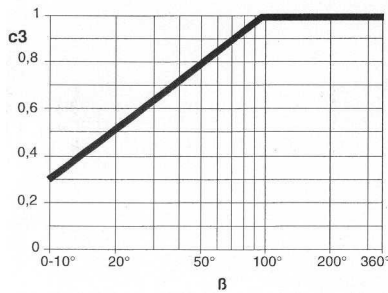

Slip Steel / bronze	Slip Steel / Steel
SMG, SFG SMG..40, SFG..40 SMG..45, SFG..45	SMGM..50 SMGM..51 SMGM..52
SS SS..45	SSA SSA..45 SSA..50

Slip Steel / Uniflon® Coef. c3=1
SME, SFE SME..40, SFE..40 SME..45, SFE..45 SMEM..50 / 51 / 52
SSE SSE..45 SSE..50

Coefficient de sollicitations c4

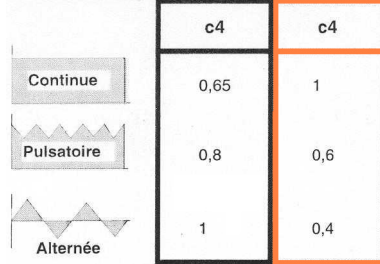

Slip Steel / bronze	Slip Steel / Steel
SMG, SFG SMG..40, SFG..40 SMG..45, SFG..45	SMGM..50 SMGM..51 SMGM..52
SS SS..45	SSA SSA..45 SSA..50

Slip Steel / Uniflon®
SME, SFE SME..40, SFE..40 SME..45, SFE..45 SMEM..50 / 51 / 52
SSE SSE..45 SSE..50

Coefficient de charges alternées et pulsatoires c5

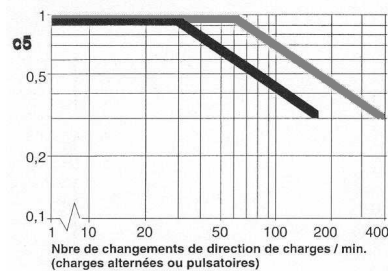

Slip Steel / bronze	Slip Steel / Uniflon®
SMG, SFG SMG..40, SFG..40 SMG..45, SFG..45	SME, SFE SME..40, SFE..40 SME..45, SFE..45 SMEM..50 / 51 / 52
SS SS..45	SSE SSE..45 SSE..50

Slip Steel / Steel
SMGM..50 SMGM..51 SMGM..52
SSA SSA..45 SSA..50

Coefficient d'entretien c6

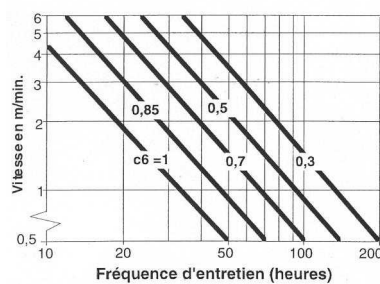

Slip Steel / bronze	Slip Steel / Steel
SMG, SFG SMG..40, SFG..40 SMG..45, SFG..45	SMGM..50 SMGM..51 SMGM..52
SS SS..45	SSA SSA..45 SSA..50

Slip Steel / Uniflon® Coef. c6=1
SME, SFE SME..40, SFE..40 SME..45, SFE..45 SMEM..50 / 51 / 52
SSE SSE..45 SSE..50

Coefficient de température c7 (Température ambiante du lieu de travail)

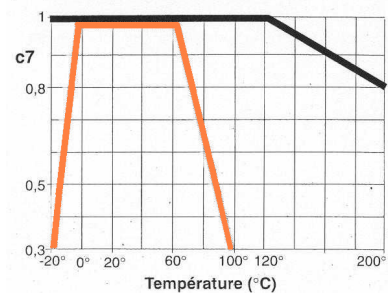

Slip Steel / bronze	Slip Steel / Steel
SMG, SFG SMG..40, SFG..40 SMG..45, SFG..45	SMGM..50 SMGM..51 SMGM..52
SS SS..45	SSA SSA..45 SSA..50

Slip Steel / Uniflon®
SME, SFE SME..40, SFE..40 SME..45, SFE..45 SMEM..50 / 51 / 52
SSE SSE..45 SSE..50

Examples of dynamic calculations

Calculation n°1: Steel / Bronze

On a machine, an automatic loading system requires size 12 rod-end bearings

1) Data

Type and size wanted:	SMG12
Dynamic radial loading:	180 daN
Type of strain:	continuous
Angle of oscillation:	± 45° (β = 180°)
Frequency:	125 osc./min
Maintenance:	1 lubrication / 18h
Ambient temperature:	50°C
Life wanted:	7,000,000 osc.

2) Checking the pressure, velocity and PV factor

$$P = \frac{F}{d_K \times C \times 0.85} = \frac{180}{22.23 \times 12 \times 0.85} = 0.79 \text{ daN/mm}^2$$

$$V = \frac{D_K \times \beta \times f}{114'600} = \frac{22.23 \times 180 \times 125}{114'600} = 4.36 \text{ m/min}$$

$$PV = P \times V = 0.79 \times 4.36 = 3.46$$

After checking the values obtained in table 1, we find that the maximum admissible PV factor is 3.5, the limit admissible velocity is 5 m/min. and the pressure maximum admissible is 5 daN/mm²

So we can continue the calculation.

3) Calculating the life

K: table p.11	Constant SMG12	85
c1: coef. p.12	Pressure: 0.79	1
c2: coef. p.12	Velocity: 4.36	1
c3: coef. p.13	Angle β = 180°	1
c4: coef. p.13	Continuous loading	0.65
c5: coef. p.13	Not applicable	1
c6: coef. p.13	1 lubrication/ 18h	0.8
c7: coef. p.13	50°C	1
c8: coef. p.11	Not applicable	1
X: coef. p.11		1

Life:

$$D = \frac{C_1 \cdot C_2 \cdot C_3 \cdot C_4 \cdot C_5 \cdot C_6 \cdot C_7 \cdot C_8 \cdot X \cdot C \cdot K \cdot 10^7}{F \cdot \beta \cdot 0.0167}$$

$$D = \frac{1 \cdot 1 \cdot 1 \cdot 0.65 \cdot 1 \cdot 0.8 \cdot 1 \cdot 1 \cdot 1 \cdot 12 \cdot 85 \cdot 10^7}{180 \cdot 180 \cdot 0.0167}$$

D = 9,800,000 oscillations (> 7,000,000 osc.)
Type SMG12 is entirely suitable for this application.

Calculation n°2: Steel / Steel

You want to fit the tower of a crane with size 16 rod-end bearings. What will the life stress surfaces below be?

1) Data

Type and size wanted:	Gr. 16 Type?
Dynamic radial loading:	2,500 daN with impacts
Type of strain:	alternating
Angle of oscillation:	± 30° (β = 120°)
Frequency:	0.5 osc./min
Maintenance:	liberal lubrication
Ambient temperature:	120 to 180°C
Life wanted:	10,000h

2) Checking the pressure, velocity and PV factor

$$P = \frac{F}{d_K \times C \times 0.85} = \frac{2,500}{28.58 \times 15 \times 0.85} = 6.9 \text{ daN/mm}^2$$

$$V = \frac{D_K \times \beta \times f}{114'600} = \frac{28.58 \times 120 \times 0.5}{114'600} = 0.015 \text{ m/min}$$

$$PV = P \times V = 6.9 \times 0.015 = 0.1$$

We have to choose a rod-end bearing withstanding 10daN/mm², so steel /steel friction. Type SMGM 16.50 does not withstand very high velocities, but in this application, the velocity is very low. An SMGM 16.50 is particularly suited to this application.

3) Calculating the life

K: table p.11	Constant SMGM 16.50	80
c1: coef. p.12	Pressure: 6.9	0.6
c2: coef. p.12	Velocity: 0.01	0.3
c3: coef. p.13	Angle β = 120°	1
c4: coef. p.13	Alternating loading	1
c5: coef. p.13	0.5 osc./min	1
c6: coef. p.13	Liberal lubrication	1
c7: coef. p.13	180°C	0.85
c8: coef. p.11	Not applicable	1
X: coef. p.11	Impacts	0.9

Life:

$$D_h = \frac{C_1 \cdot C_2 \cdot C_3 \cdot C_4 \cdot C_5 \cdot C_6 \cdot C_7 \cdot C_8 \cdot X \cdot C \cdot K \cdot 10^7}{F \cdot \beta \cdot f}$$

$$D_h = \frac{0.6 \cdot 0.3 \cdot 1 \cdot 1 \cdot 1 \cdot 1 \cdot 0.85 \cdot 1 \cdot 0.9 \cdot 15 \cdot 80 \cdot 10^7}{2500 \cdot 120 \cdot 0.5}$$

D_h = 11,000 hours (> 10,000 h)
It is wise to choose an SMGM16.50 rod-end bearing for this lifting system.

NB: use grease that withstands the 180°C working temperature

Calculation n°3: Steel / Uniflon® E

An SF..30 rod-end bearing is going to be used for the transmission on a fairground ride. It must be able to run maintenance-free. What type should be used?

1) Data

Type and size wanted:	Gr. 30 Type SF..
Dynamic radial loading:	2,500 daN
Type of strain:	alternating
Angle of oscillation:	± 1.5° (β = 6°)
Frequency:	80 osc./min
Maintenance:	self-lubricating
Ambient temperature:	0 to 45°C, dust
Life wanted:	3,000 h

2) Checking the pressure, velocity and PV factor

$$P = \frac{F}{d_K \times C \times 0.85} = \frac{2,500}{50.8 \times 25 \times 0.85} = 2.32 \text{ daN/mm}^2$$

$$V = \frac{D_K \times \beta \times f}{114'600} = \frac{50.8 \times 6 \times 80}{114'600} = 0.21 \text{ m/min}$$

$$PV = P \times V = 2.32 \times 0.21 = 0.49$$

After checking the values obtained in table 1, we find that the pressure, velocity and PV factor are below the maximum admissible values. Checking the static loading of an SFE30: 5,130 daN, which is thus greater than the loading stated. So the SFE30 is suitable for this application.

3) Calculating the life

K: table p.11	Constant SFE30	105
c1: coef. p.12	Pressure: 2.32	1
c2: coef. p.12	Velocity: 0.21	1
c3: coef. p.13	Angle β = 6°	1
c4: coef. p.13	Alternating loading	0.4
c5: coef. p.13	80 osc./min	0.5
c6: coef. p.13	self-lubricating	1
c7: coef. p.13	0 to 45°C	1
c8: coef. p.11	Not applicable	1
X: coef. p.11	Dusty	0.8

Life:

$$D_h = \frac{C_1 \cdot C_2 \cdot C_3 \cdot C_4 \cdot C_5 \cdot C_6 \cdot C_7 \cdot C_8 \cdot X \cdot C \cdot K \cdot 10^7}{F \cdot \beta \cdot f}$$

$$D_h = \frac{1 \cdot 1 \cdot 1 \cdot 0.4 \cdot 0.5 \cdot 1 \cdot 1 \cdot 1 \cdot 0.8 \cdot 25 \cdot 105 \cdot 10^7}{2500 \cdot 6 \cdot 80}$$

D = 3,500 hours (> 3,000 h.)

The Unibal SFE30 rod-end bearing will ensure that the ride runs correctly.

Calculation n°4: Steel / Steel

Several type SSA 3.45 spherical bearings are fitted to scale models (model boats). Despite the corrosive environment and stresses, these Unibals must withstand 300,000 oscillations.

1) Data

Type and size wanted:	SSA 3.45
Dynamic radial loading:	190 daN
Type of strain:	continuous
Angle of oscillation:	β = 360°
Frequency:	20 rpm
Maintenance:	liberal lubrication
Ambient temperature:	5 to 30°C
Life wanted:	300,000 osc.

2) Checking the pressure, velocity and PV factor

$$P = \frac{F}{d_K \times C \times 0.85} = \frac{190}{7.93 \times 4.5 \times 0.85} = 6.26 \text{ daN/mm}^2$$

$$V = \frac{D_K \times \beta \times f}{114'600} = \frac{7.93 \times 360 \times 20}{114'600} = 0.50 \text{ m/min}$$

$$PV = P \times V = 6.26 \times 0.5 = 3.12$$

After checking the values obtained, we find that the velocity and PV factor are acceptable. As concerns pressure, an SSA 3.45 withstands pressure of 10 daN/mm². The admissible static loading is much greater than 190 daN. So we now have to check the required number of oscillations.

3) Calculating the life

K: table p.11	Constant SSA 3.45	70
c1: coef. p.12	Pressure: 6.26	0.62
c2: coef. p.12	Velocity: 0.5	0.35
c3: coef. p.13	Angle β = 360°	1
c4: coef. p.13	Continuous loading	0.65
c5: coef. p.13	Not applicable	1
c6: coef. p.13	Liberal lubrication	1
c7: coef. p.13	5 to 30°C	1
c8: coef. p.11	Not applicable	1
X: coef. p.11		1

Life:

$$D = \frac{C_1 \cdot C_2 \cdot C_3 \cdot C_4 \cdot C_5 \cdot C_6 \cdot C_7 \cdot C_8 \cdot X \cdot C \cdot K \cdot 10^7}{F \cdot \beta \cdot 0.0167}$$

$$D = \frac{0.62 \cdot 0.35 \cdot 1 \cdot 0.65 \cdot 1 \cdot 1 \cdot 1 \cdot 1 \cdot 1 \cdot 4.5 \cdot 70 \cdot 10^7}{190 \cdot 360 \cdot 0.0167}$$

D_h = 389,000 osc. (> 300,000 osc.)

According to the calculation performed, SSA 3.45 spherical bearings are suitable for this application.

Uniflon® Type E

Uniflon® is the registered trademark of the self-lubricating fabric fitted exclusively to Unibal® self-lubricating spherical bearings.

Uniflon® E self-lubricating fabric comes from a development for aerospace applications and complies with the SAE-AS81820 standard.

Uniflon® E can be used in combination with different materials such as toughened steel, aluminium and titanium, in various environments and extreme temperatures from -30°C to $+175^{\circ}\text{C}$.

Because of its composition, Uniflon® E is unique in the PTFE (Polytetrafluoroethylene) fibre friction materials range

Composition

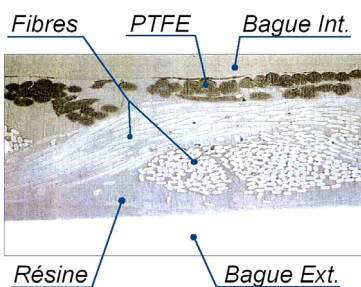

Features

The perfect composite, Uniflon® E brings you the following benefits:

- A fabric (fibres) that is highly resistant to heat, abrasion, breaking and compression.
- A high proportion of PTFE fibres, which have superb slip properties.
- A matrix chemically linked by a resin with a low coefficient of friction.

Spherical bearings with self-lubricating linings do not have a constant coefficient of friction for all applications. If the applied loading increases, the coefficient of friction decreases. Similarly, if the temperature decreases, the coefficient of friction increases.

The following figure shows how the in the coefficient of friction reduces as the temperature rises.

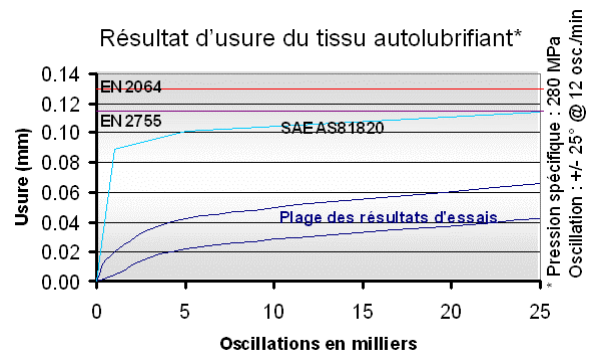
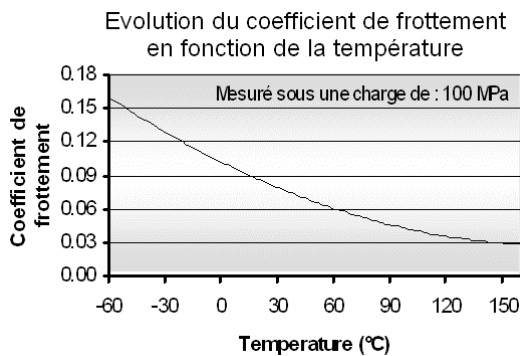

Alternatives

For applications at low loadings, high temperature and/or higher velocity, we suggest a self-lubricating lining with more suitable characteristics:

- Uniflon® type VV

On request, we make other maintenance-free formulas such as:

- Plastic materials
- Self-lubricating bronzes

Lubrication and maintenance

Lubrication and the maintenance apply to products not fitted with self-lubricating fabric (Uniflon®), i.e. spherical bearings and rod-end bearings of **SMG/SFG**, **SS/SSA** type - whose the slip contact is of the following type:

- Steel / bronze
- Steel / steel

These products are built so that an internal groove carries the lubricating liquid to the slip surface.

Regular lubrication is necessary for two reasons:

- To provide the application with optimal running conditions to extend its life.
- To prevent corrosion, mainly due to steel/steel friction

Our rod-end bearings, from size 8, are fitted with a small lubricator, in order to minimise weakening mounts – symbol **G** (SMG..., SFG..)

The lubrication tip to use is the one designed for type D concave head lubricators.

Standard lubrication

The Mobil **Greaserex 47** grease (ISO 3498 XM2) is used for assembling all types of product where grease is necessary.

This universal grease is an ideal lubricant.

Features:

- Base: calcium complex
- Drop point: 260°C
- Working temperature: -25°C to +125°C
- Excellent wear protection properties
- Withstands shearing. Binding of the bearing possible, partial lining given when substantial vibration.

Special lubrication

We offer different types of lubrication and surface treatment, on request. For example:

1) Molykote BR2 plus, very haute quality grease:

- Base: lithium soap, mineral oil
- Drop point: 185°C
- Working temperature: -30°C to +130°C
- Multifunction grease containing solid lubricants
- Excellent properties under extreme pressure and ideally suited to high velocities
- A permanent film of grease ensures safety and extends lubrication intervals

This grease is recommended for very high stress levels (loading or velocity).

2) Moly-PAUL PBC, synthetic grease, organo-metallic complex:

- Excellent anti-corrosive.
- Excellent resistance to salt, acid and bases.
- Excellent seizure prevention.
- Does not carbonise or run at temperature
- Provides long-lasting lubrication
- Working temperatures: -10°C to 1,100°C for static (300°C for dynamic, slow movement)

3) Molykote 106, slip coating:

- Before assembly, the sphere is treated to ensure lasting lubrication. Once created, the film reduces wear and optimises operating safety even after long stationary periods.

Neoprene protection

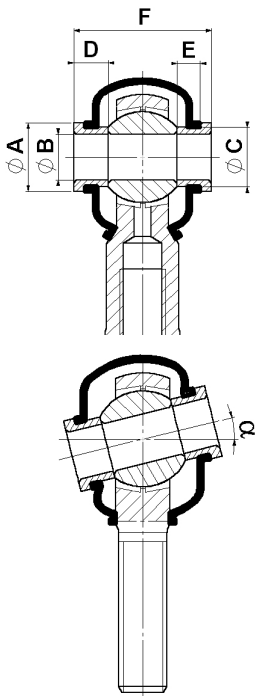

This protection completely conserves the rod-end bearing from any external attack:

- Dust
- Abrasives
- Corrosion
- Chemicals

Once filled with silicon based grease, the neoprene protection ensures permanent lubrication.



Features:

- Material: neoprene to standard NF T 46-018
- Colour: black
- Working temperature: -30°C to +120°C
- Good resistance to oil, grease, chemicals, seawater, tropical climate
- Not advised for applications in permanent contact with oxidising agents, applications where the rotation of the inner bush causes complete rotations or applications at high velocity

Rod size	Protection ref.	Spacer bush ref.	ØA	ØB	ØC	D	E	F	α°
SM/SF6	PR1	* BD6	11	6	8.7	6	4	21	13°
SM/SFG8		BD8	12	8	10.3			24	
SM/SFG10	PR2	BD10	14	10	12.5	8	6	26	13°
SM/SFG12		BD12	17	12	15			32	
SM/SFG14	PR3	BD14	19	14	16.8	8	6	35	16°
SM/SFG16		BD16	21	16	19			37	
SM/SFG18	PR4	* BD18	25	18	21	10	8	39	15°
SM/SFG20		* BD20	28	20	24			45	
SM/SFG22		* BD22	29	22	25			48	
SM/SFG25		* BD25	33	25	29			51	

* These spacer bushes are not held in stock

2RS arrangement

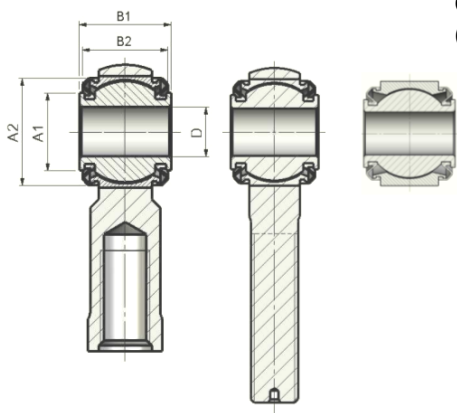

On request, we make sealed rod-end bearings, fitted with bellows. (minimum quantity required)

Type ..RS	D	A1	A2	B1	B2	α°
8	6	10.5	18.5	19	18.5	10°
10	8	12.5	21.5	21	20	
12	10	14.5	25.5	23	22.5	12°
14	12	16.5	29.5	26	24.5	10°
16	14	19	32.5	28	27	12°
18	16	21	35.5	30	29	
20	18	23	39	32	31	
22	20	25.5	42.5	35	34	
25	22	29	46.5	38	37	
30	25	33.5	55	44	43	

Play

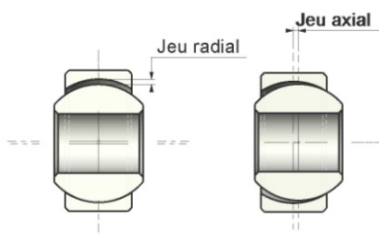

Spherical bearings and rod-end bearings have initial play or slip torque that is specific to the type and size. Working play is typified by the radial and axial movements of the inner bush. For our standard construction, the relationship between the radial and axial play is as follows:

$$\text{Axial play} = \text{Radial play} \times 2.5$$

Play given in the table below is the max. value for our standard spherical bearings, tested under a loading of ± 10 daN.

Some of our products are routinely assembled with reduced play, or even without play (types in **bold**):

- Series .40 and .50 (all types)
- Self-lubricated types (all series)

Size	2 to 6	8 to 12	14 to 18	20 to 22	25 to 30
Max. radial play	0.03	0.04	0.05	0.06	0.08

These play values are valid for parts of SM/SMG, SF/SFG, SS/SSA type in the standard series and .45 (stainless steel) series

Torque

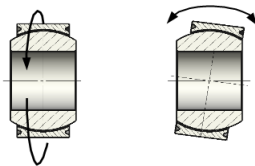

The spherical bearing's torque can be measured in relation to two perpendicular axes.

There is:

- rotation torque
- tilt torque.

For parts in this catalogue, there is the relationship:

$$\text{Tilt torque} = \frac{\text{Rotation torque}}{1.6}$$

The torque given in the table below are for the min. and max. values tested.

General rules

- 1) The torque should be reduced for high velocity applications (low loading). If there must be no play for your application, we offer variants with reduced play or even without play, to your requirements.
- 2) The torque should be raised for applications with high or alternating loadings, or with impacts and low velocity.
- 3) An abnormally short life can result from inappropriate torque. For non-standard applications, we offer advice and will adapt the torque to your requirements for optimal running.

Size	Series Type	Rotation torque (daNcm)								
		-		.40		.45		.50		
		SM, SMG SF, SFG SS, SSA	SME SFE SSE	SM, SMG SF, SFG	SME SFE	SM, SMG SF, SFG SS, SSA	SME SFE SSE	SMM, SMGM	SME SSE	SSA
2 to 5	< 0.4	0.1 – 0.7	0.6 – 3.4		< 0.4	0.1 – 0.7	1 – 5		1 – 4	
6 to 10	< 0.6	0.2 – 1.3	1.0 – 6.0		< 0.6	0.2 – 1.3	2 – 10		1 – 5	
12 to 18	< 1.0	0.3 – 2.1	1.6 – 10		< 1.0	0.3 – 2.1	4 – 16		2 – 8	
20 to 30	< 1.7	0.5 – 3.4	2.5 – 16		< 1.7	0.5 – 3.4	-		3 – 10	

Spherical bearings with a reference **in bold** are supplied with zero radial play

The maximum tilt angle depends on the type of assembly. It is not recommended to exceed the tilt angle given in the tables of dimensions.

The maximum tilt angle is governed by:

- d_k the diameter of the sphere
- d the diameter of the bore
- d_1 the diameter of flat
- B the width of the bush
- C the width of the cage or mount

$$\alpha_1 = \cos^{-1}\left(\frac{C}{d_k}\right) - \operatorname{tg}^{-1}\left(\frac{D_1}{B}\right)$$

$$\alpha_2 = \cos^{-1}\left(\frac{C}{d_k}\right) - \sin^{-1}\left(\frac{d_1}{B}\right)$$

Size	Value of angle α	
	α_1	α_2
2	16°	33°
3	15°	
4	14°	31°
5	13°	30°
6		
8	14°	25°
10	13°	25°
12	16°	24°
14	15°	24°
16		
18		
20	15°	23°
22		
25		
30	17°	24°

Assembly instructions

After assembly, there must be slip between the inner bush and outer bush of the spherical bearing. To achieve this, the inner bush should be firmly fixed to the shaft, and the outer bush fixed to the housing in which it is fitted.

1) Fitting the spherical bearing in its housing

To ensure correct operation, it is important to comply with adjustments when fitting. It is advisable to tighten spherical bearings in their housing in accordance with the values in the following table:

Size	Self-lubricated spherical bearings	Metal/Metal spherical bearings
2 to 4	0.000 to 0.010mm	0.005 to 0.015mm
5 to 8	0.005 to 0.015mm	0.010 to 0.020mm
10 to 16	0.005 to 0.020mm	0.010 to 0.025mm
18 to 30	0.005 to 0.025mm	0.010 to 0.030mm

Parts should be assembled using a press. Tooling used should ensure perfect alignment of the axis of the spherical bearing and the axis housing when assembling. There should be a 10 to 20° chamfer on the housing so as to facilitate seating.

Caution:

The fixture of the spherical bearing in its housing is not under any circumstances a mechanical stop keeping the spherical bearing from movement due to an axial loading.

To prevent the cage from slipping, bearing surfaces or stop segments should be provided or it must be crimped.

2) Fitting the shaft in the bush

For self-lubricated spherical bearings, it is essential that the shaft is dry-fitted. An m6 adjustment will be used for the standard and stainless steel series with steel/steel friction contact, and a k6 adjustment for all other lines.

Incorrect assembly can adversely affect the life of the spherical bearing. A very high proportion of failures directly related to incorrect assembly.

Here are some examples of common mistakes:

- Adjustment too tight between the spherical bearing and the housing.
- Unsuitable tools used for assembly
- Excess force applied when assembling.

Materials

The materials of the different constituents of Unibal standard spherical bearings, shown on the following pages, are given as an indication.

We reserve the right to change them for other materials with similar properties that do not alter the mechanical characteristics of spherical bearings.

Standard series SM/SF SMG/SFG

General mechanics

Use

- Usual, standard, general mechanical

Slip contact

- Brass or bronze spacers / Bearing steel bush

Maintenance

- Needs regular lubrication.
- Integral lubricator on rods from size 8 (letter G)

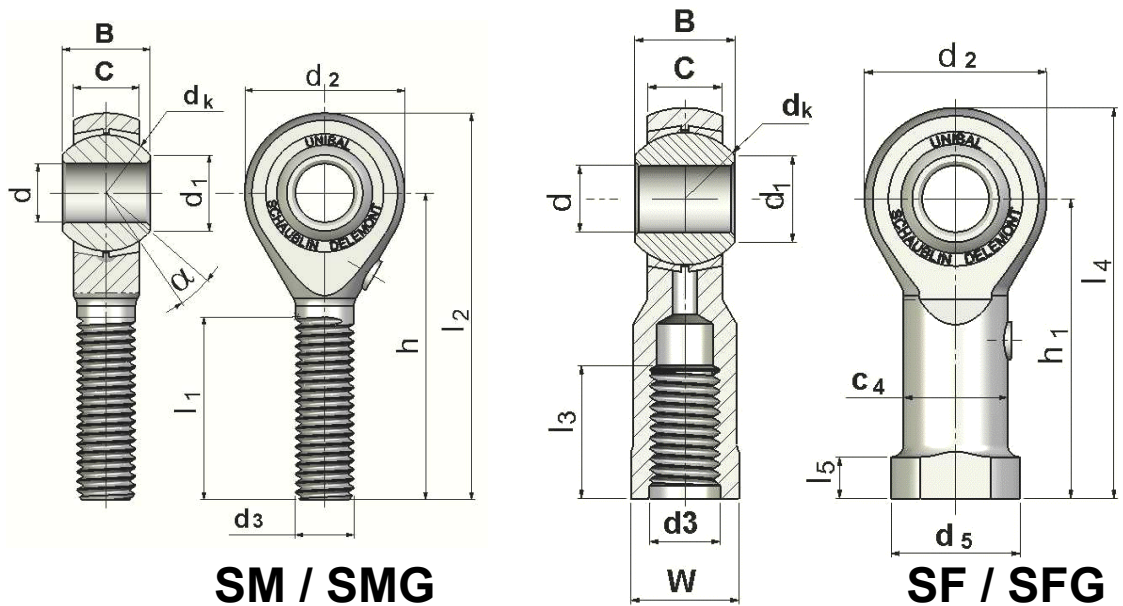

SM / SMG

SF / SFG

Type		d	B	C	dk	d1	d2	d3
		H7	$\begin{matrix} 0 \\ -0,05 \end{matrix}$	± 0.2				(SM) 6 g (SF) 6 H
SM 2	SF 2	2	4.8	3.6	6.00	3.60	9	M2 x0.4
SM 3	SF 3	3	6	4.5	7.93	5.18	12	M3 x0.5
SM 4	SF 4	4	7	5.25	9.52	6.46	14	M4 x0.7
SM 5	SF 5	5	8	6	11.11	7.71	16	M5 x0.8
SM 6	SF 6	6	9	6.75	12.70	8.96	18	M6 x1
SMG 8	SFG 8	8	12	9	15.88	10.40	22	M8 x1.25
SMG 10	SFG 10	10	14	10.5	19.05	12.92	26	M10 x1.5
SMG 12	SFG 12	12	16	12	22.23	15.43	30	M12 x1.75
SMG 14	SFG 14	14	19	13.5	25.40	16.86	34	M14 x2
SMG 16	SFG 16	16	21	15	28.58	19.39	38	M16 x2
SMG 18	SFG 18	18	23	16.5	31.75	21.89	42	M18 x1.5
SMG 20	SFG 20	20	25	18	34.92	24.38	46	M20 x1.5
SMG 22	SFG 22	22	28	20	38.10	25.84	50	M22 x1.5
SMG 25	SFG 25	25	31	22	42.85	29.60	56	M24 x2
SMG 30	SFG 30	30	37	25	50.80	34.80	66	M30 x2



Standard series SM/SF SMG/SFG

General mechanics

Dimensions:

- Available in sizes 2 to 30
- Please ask for bore diameters over 30mm

Materials

Mount:

- Size 2 to 12: steel C35Pb (1.0502), zinc chromated blue
- Size 14 to 30: steel C35 (1.0501), zinc chromated blue

Bush:

- Bearing steel 100Cr6 (1.3505) hardened, chrome, sizes 4 to 20

Spacers:

- Size 2 to 16: CuZn40MnPb
- Size 18 to 30: GC-CuSn7ZnPb

Notes

Left-hand thread: add the suffix L in the description

- Example: SFL 6

By request:

- Produced with reduced play
- Magnetic fault inspection (suffix M – Example: SMGM12)
- Original lubricant - Molykote BR2 (see page 17)

d	d ₅	C ₄	h	h ₁	l ₁	l ₂	l ₃	l ₄	l ₅	W	α°	Basic static loading C ₀ * (daN)	Weight (g)	
mm					± 0.5		± 0.5						SMG	SFG
2	4.5	3.8	18	16	9	22.5	6	20.5	2.5	4.5	16	220	2	3
3	6.5	5.0	27	21	15	33	7.5	27	3	5.5	15	420	5	7
4	8.5	6.5	30	24	18	37	10	31	3.5	7	14	530	9	11
5	9.5	7.5	33	27	20	41	12.5	35	4	8	13	650	12	14
6	12	9.5	36	30	22	45	13	39	5	10	13	800	18	22
8	16	12.5	42	36	25	53	16	47	5	13	14	1,180	35	38
10	19	15.0	48	43	29	61	19	56	6.5	16	14	1,550	57	70
12	22	17.5	54	50	33	69	20	65	6.5	18	13	1,970	87	110
14	25	20.0	60	57	36	77	25	74	8	21	16	2,660	120	150
16	27	22.0	66	64	40	85	30	83	8	24	15	3,210	170	200
18	31	25.0	72	71	44	93	33	92	10	27	15	3,830	240	280
20	34	27.5	78	77	47	101	36	100	10	30	15	4,500	320	370
22	37	30.0	84	84	51	109	40	109	12	34	15	5,300	420	480
25	42	33.5	94	94	57	122	42	122	12	36	15	6,450	580	670
30	50	40.0	110	110	66	143	50	143	15	46	17	8,530	980	1 080

* Static loadings are not necessarily comparable from one manufacturer to another. They directly depend on the criteria employed, the type of steel used and the dimensions of the rod-end bearing

Special Thread Series SMG/SFG..20

General mechanics

Use

- General mechanics requiring a special MF (metric fine) pitch or an M (metric) pitch

Slip contact

- Brass or bronze spacers / Bearing steel bush

Maintenance

- Requires regular lubrication.

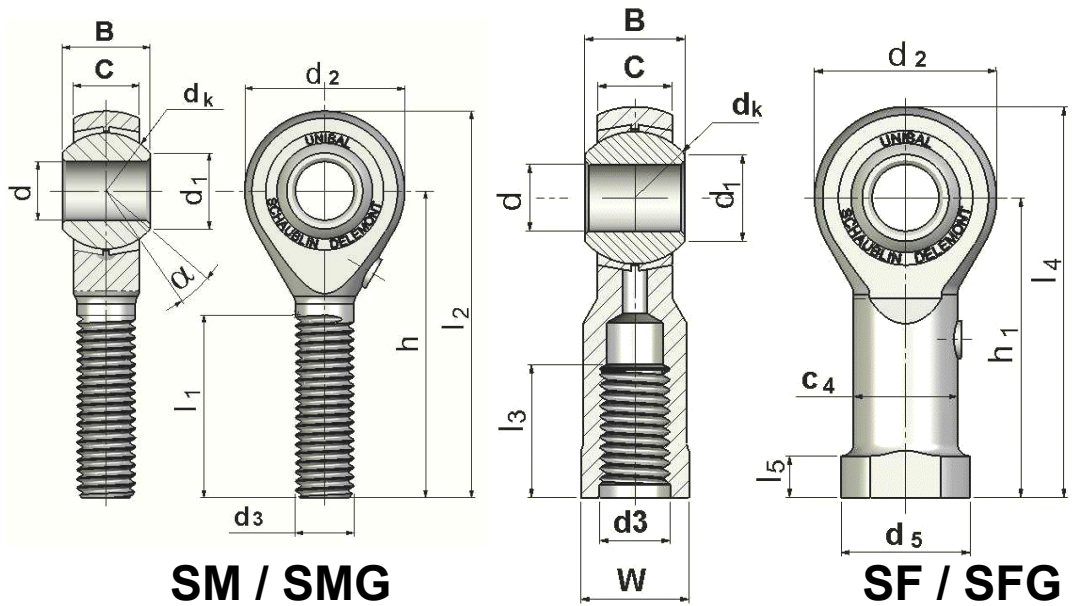

SM / SMG

SF / SFG

Type		d	B	C	dk	d1	d2	d3
		H7	$\begin{matrix} 0 \\ -0,05 \end{matrix}$	± 0.2				$\begin{matrix} \text{(SM) 6 g} \\ \text{(SF) 6 H} \end{matrix}$
SMG 8 .20	SFG* 8 .20	8	12	9	15.88	10.40	22	M8 x1
SMG 10 .20	SFG 10 .20	10	14	10.5	19.05	12.92	26	M10 x1
SMG 10 .22	SFG* 10 .22	10	14	10.5	19.05	12.92	26	M10 x1.25
SMG 12 .20	SFG 12 .20	12	16	12	22.23	15.43	30	M12 x1.5
SMG 12 .22	SFG* 12 .22	12	16	12	22.23	15.43	30	M12 x1.25
SMG 14 .20	SFG 14 .20	14	19	13.5	25.40	16.86	34	M14 x1.5
SMG 16 .20	SFG* 16 .20	16	21	15	28.58	19.39	38	M16 x1.5
SMG 18 .20	SFG 18 .20	18	23	16.5	31.75	21.89	42	M18 x2.5
SMG 20 .20	SFG 20 .20	20	25	18	34.92	24.38	46	M20 x2.5
SMG 22 .20	SFG 22 .20	22	28	20	38.10	25.84	50	M22 x2.5
SMG 25 .20	SFG 25 .20	25	31	22	42.85	29.60	56	M24 x3
SMG 30 .20	SFG 30 .20	30	37	25	50.80	34.80	66	M30 x3.5

* CETOP thread (fine thread for hydraulic cylinder)

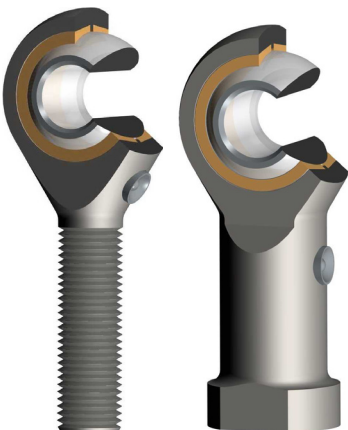

Special Thread Series SMG/SFG..20

General mechanics

Dimensions:

- Available in sizes 8 to 30
- Please ask us for bore diameters over 30mm

Materials

Mount:

- Size 8 to 12: steel C35Pb (1.0502), zinc chromated blue
- Size 14 to 30: steel C35 (1.0501), zinc chromated blue

Bush:

- Bearing steel 100Cr6 (1.3505) hardened, chrome, sizes 8 to 20

Spacers:

- Size 8 to 16: CuZn40MnPb
- Size 18 to 30: GC-CuSn7ZnPb

Notes

Left-hand thread: add the suffix L in the description

- Example: SFLG8.20

By request:

- Produced with reduced play
- Magnetic fault inspection (suffix M – Example: SMGM12.20)
- Original lubricant - Molykote BR2 (see page 17)

d mm	d ₅	C ₄	h	h ₁	l ₁ ± 0.5	l ₂	l ₃ ± 0.5	l ₄	l ₅	W	α°	Basic static loading C ₀ * (daN)	Weight (g)	
													SMG	SFG
8	16	12.5	42	36	25	53	16	47	5	13	14	1,180	35	38
10	19	15.0	48	43	29	61	19	56	6.5	16	14	1,550	57	70
10	19	15.0	48	43	29	61	19	56	6.5	16	14	1550	57	70
12	22	17.5	54	50	33	69	20	65	6.5	18	13	1,970	87	110
12	22	17.5	54	50	33	69	20	65	6.5	18	13	1970	87	110
14	25	20.0	60	57	36	77	25	74	8	21	16	2,660	120	150
16	27	22.0	66	64	40	85	30	83	8	24	15	3,210	170	200
18	31	25.0	72	71	44	93	33	92	10	27	15	3,830	240	280
20	34	27.5	78	77	47	101	36	100	10	30	15	4,500	320	370
22	37	30.0	84	84	51	109	40	109	12	34	15	5,300	420	480
25	42	33.5	94	94	57	122	42	122	12	36	15	6,450	580	670
30	50	40.0	110	110	66	143	50	143	15	46	17	8,530	980	1 080

* Static loadings are not necessarily comparable from one manufacturer to another. They directly depend on criteria employed, the type of steel used and the dimensions of the rod-end bearing

High Tensile Series SM/SF..40 SMG/SFG..40

Use

- Application in all fields where static loadings are high, at reduced velocities

Slip contact

- Bronze spacers / Bearing steel bush

Maintenance

- Requires regular lubrication.
- Integral lubricator on rods from size 8 (letter G)

Dimensions:

- Available in sizes 5 to 30
- Please ask us for bore diameters over 30mm

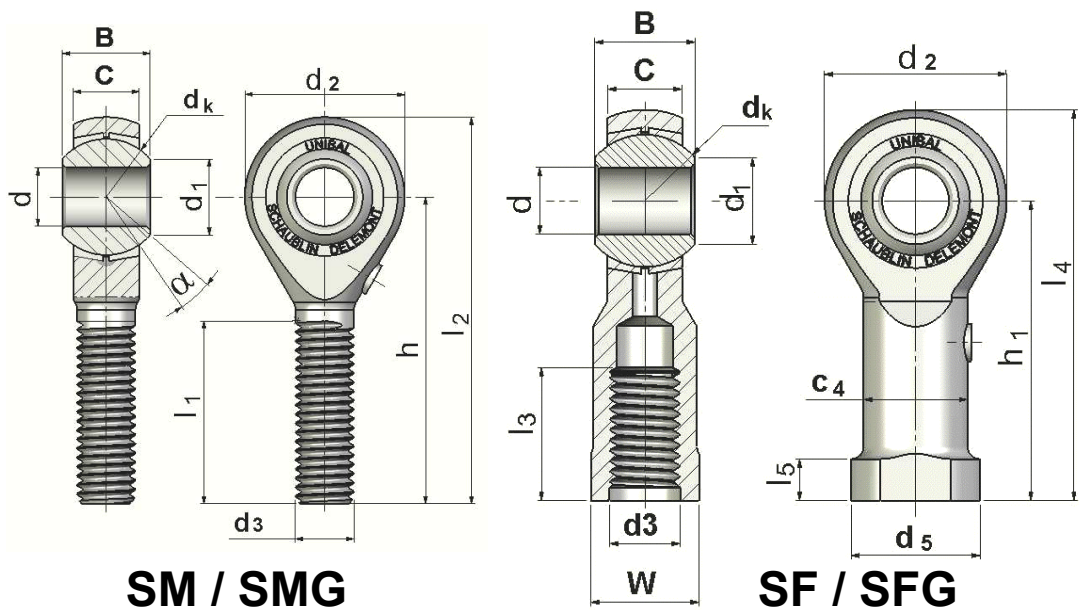

SM / SMG

SF / SFG

Type		d	B	C	dk	d1	d2	d3		
		H7	⁰ _{-0,05}	± 0.2				(SM) 6 g (SF) 6 H		
SM	5.40	SF	5.40	5	8	6	11.11	7.71	16	M5 x0.8
SM	6.40	SF	6.40	6	9	6.75	12.70	8.96	18	M6 x1
SMG	8.40	SFG	8.40	8	12	9	15.88	10.40	22	M8 x1.25
SMG	10.40	SFG	10.40	10	14	10.5	19.05	12.92	26	M10 x1.5
SMG	12.40	SFG	12.40	12	16	12	22.23	15.43	30	M12 x1.75
SMG	14.40	SFG	14.40	14	19	13.5	25.40	16.86	34	M14 x2
SMG	16.40	SFG	16.40	16	21	15	28.58	19.39	38	M16 x2
SMG	18.40	SFG	18.40	18	23	16.5	31.75	21.89	42	M18 x1.5
SMG	20.40	SFG	20.40	20	25	18	34.92	24.38	46	M20 x1.5
SMG	22.40	SFG	22.40	22	28	20	38.10	25.84	50	M22 x1.5
SMG	25.40	SFG	25.40	25	31	22	42.85	29.60	56	M24 x2
SMG	30.40	SFG	30.40	30	37	25	50.80	34.80	66	M30 x2

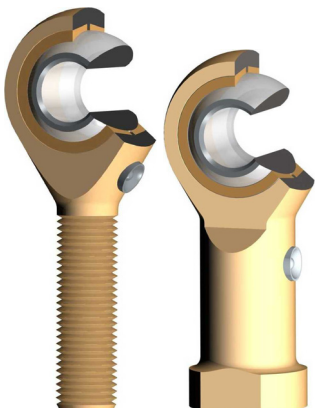

High Tensile Series SM/SF..40 SMG/SFG..40

Materials

Mount:

- Steel C45 (1.0503) treated, zinc chromated yellow

Bush:

- Bearing steel 100Cr6 (1.3505) hardened, chrome (size 5 to 20)

Spacers:

- GC-CuSn7ZnPb

Notes

Left-hand thread: add the suffix L in the description

- Example: SMLG 12.40

By request:

- Produced with reduced play
- Magnetic fault inspection (suffix M – Example: SMGM12.40)
- Hard chrome plated bush
- Original lubricant - Molykote BR2 (see page 17)
- CETOP or special thread

d mm	d ₅	C ₄	h	h ₁	l ₁ ± 0.5	l ₂	l ₃ ± 0.5	l ₄	l ₅	W	α°	Basic static loading C ₀ (daN)	Weight (g)	
													SMG	SFG
5	9.5	7.5	33	27	20	41	12.5	35	4	8	13	990	12	14
6	12	9.5	36	30	22	45	13	39	5	10	13	1,190	18	22
8	16	12.5	42	36	25	53	16	47	5	13	14	1,760	35	38
10	19	15.0	48	43	29	61	19	56	6.5	16	14	2,300	57	70
12	22	17.5	54	50	33	69	20	65	6.5	18	13	2,920	87	110
14	25	20.0	60	57	36	77	25	74	8	21	16	3,610	120	150
16	27	22.0	66	64	40	85	30	83	8	24	15	4,370	170	200
18	31	25.0	72	71	44	93	33	92	10	27	15	5,210	240	280
20	34	27.5	78	77	47	101	36	100	10	30	15	6,120	320	370
22	37	30.0	84	84	51	109	40	109	12	34	15	7,210	420	480
25	42	33.5	94	94	57	122	42	122	12	36	15	8,780	580	670
30	50	40.0	110	110	66	143	50	143	15	46	17	11,610	980	1 080

Stainless Steel Series

SM/SF..45 SMG/SFG..45

Use

- Difficult environments, washroom fittings, laboratories, etc...
- Exposure to weather, oxidising and corrosive environments (water, humidity, etc.)

Slip contact

- Bronze spacers / Stainless steel bush

Maintenance

- Requires regular lubrication.
- Integral lubricator on rods from size 8 (letter G)

Dimensions:

- Available in sizes 3 to 30
- Please ask us for bore diameters over 30mm

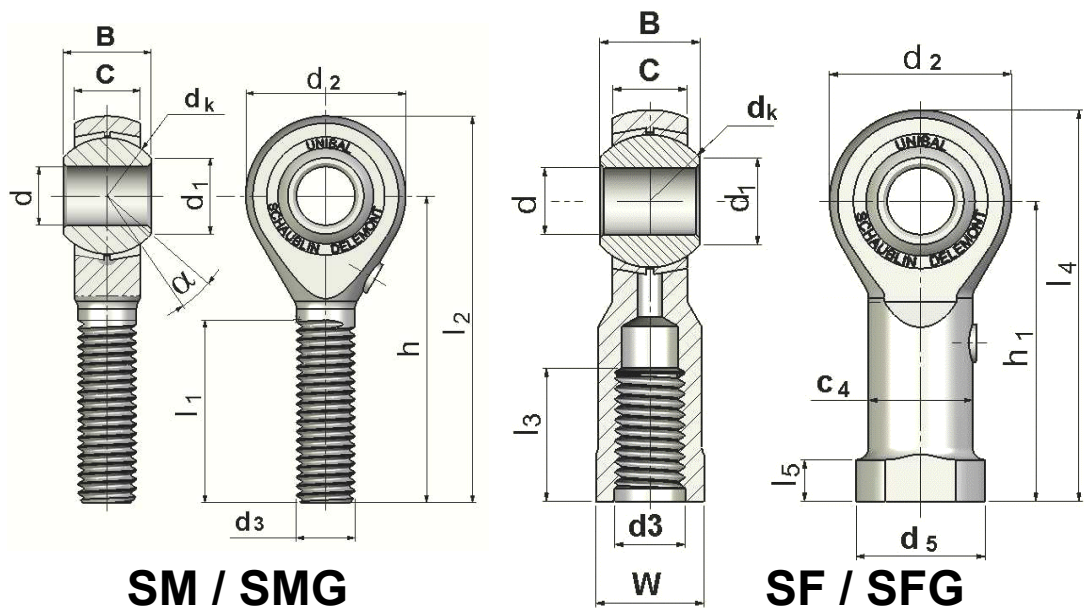

SM / SMG

SF / SFG

Type		d	B	C	dk	d1	d2	d3
		H7	$\begin{matrix} 0 \\ -0,05 \end{matrix}$	± 0.2				(SM) 6 g (SF) 6 H
SM 3 .45	SF 3 .45	3	6	4.5	7.93	5.18	12	M3 x0.5
SM 4 .45	SF 4 .45	4	7	5.25	9.52	6.46	14	M4 x0.7
SM 5 .45	SF 5 .45	5	8	6	11.11	7.71	16	M5 x0.8
SM 6 .45	SF 6 .45	6	9	6.75	12.70	8.96	18	M6 x1
SMG 8 .45	SFG 8 .45	8	12	9	15.88	10.40	22	M8 x1.25
SMG 10 .45	SFG 10 .45	10	14	10.5	19.05	12.92	26	M10 x1.5
SMG 12 .45	SFG 12 .45	12	16	12	22.23	15.43	30	M12 x1.75
SMG 14 .45	SFG 14 .45	14	19	13.5	25.40	16.86	34	M14 x2
SMG 16 .45	SFG 16 .45	16	21	15	28.58	19.39	38	M16 x2
SMG 18 .45	SFG 18 .45	18	23	16.5	31.75	21.89	42	M18 x1.5
SMG 20 .45	SFG 20 .45	20	25	18	34.92	24.38	46	M20 x1.5
SMG 22 .45	SFG 22 .45	22	28	20	38.10	25.84	50	M22 x1.5
SMG 25 .45	SFG 25 .45	25	31	22	42.85	29.60	56	M24 x2
SMG 30 .45	SFG 30 .45	30	37	25	50.80	34.80	66	M30 x2



Stainless Steel Series SM/SF..45

SMG/SFG..45

Materials

Mount:

- Stainless steel X10CrNiS18-9 (1.4305) or X5CrNi18-10 (1.4301)

Bush:

- Stainless steel X46Cr13 (1.4034), hardened

Spacers:

- GC-CuSn7ZnPb

Notes

Left-hand thread: add the suffix L in the description

- Example: SMLG 12.45

By request:

- Produced with reduced play
- Stainless steel hard chrome plated bush
- Original lubricant - Molykote BR2 (see page 17)
- Made entirely from stainless steel
- Other steels

d mm	d ₅	C ₄	h	h ₁	l ₁ ± 0.5	l ₂	l ₃ ± 0.5	l ₄	l ₅	W	α°	Basic static loading C ₀ (daN)	Weight (g)	
													SMG	SFG
3	6.5	5.0	27	21	15	33	7.5	27	3	5.5	15	290	5	7
4	8.5	6.5	30	24	18	37	10	31	3.5	7	14	360	9	11
5	9.5	7.5	33	27	20	41	12.5	35	4	8	13	440	12	14
6	12	9.5	36	30	22	45	13	39	5	10	13	540	18	22
8	16	12.5	42	36	25	53	16	47	5	13	14	820	35	38
10	19	15.0	48	43	29	61	19	56	6.5	16	14	1,070	57	70
12	22	17.5	54	50	33	69	20	65	6.5	18	13	1,360	87	110
14	25	20.0	60	57	36	77	25	74	8	21	16	1,680	120	150
16	27	22.0	66	64	40	85	30	83	8	24	15	2,030	170	200
18	31	25.0	72	71	44	93	33	92	10	27	15	2,420	240	280
20	34	27.5	78	77	47	101	36	100	10	30	15	2,850	320	370
22	37	30.0	84	84	51	109	40	109	12	34	15	3,350	420	480
25	42	33.5	94	94	57	122	42	122	12	36	15	4,080	580	670
30	50	40.0	110	110	66	143	50	143	15	46	17	5,400	980	1080

Competition Series SMM..50/51 SMGM..50/51/52

Use

- Application in all fields where static loadings are high, at low velocities

Slip contact

- Stainless steel spacers / Chrome steel bush

Maintenance

- Requires regular lubrication.
- Integral lubricator on rods from size 8 (letter G)

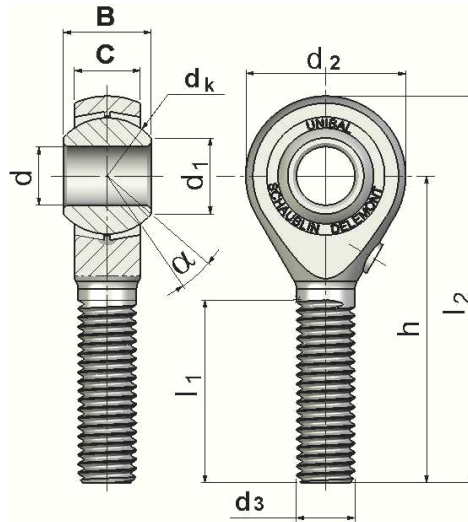

SMM / SMGM

Type	d H7	B 0 - 0,05	C ± 0.2	dk	d ₁	d ₂	d ₃ 6 g	h	l ₁	l ₂	α°	Basic static loading C ₀ (daN)	Weight (g)
SMM 5 .50	5	8	6	11.11	7.71	16	M5 x0.8	33	20	41	13	1,290	12
SMM 6 .50	6	9	6.75	12.70	8.96	18	M6 x1	36	22	45	13	1,550	18
SMGM 8 .50	8	12	9	15.88	10.40	22	M8 x1.25	42	25	53	14	2,290	35
SMGM 10 .50	10	14	10.5	19.05	12.92	26	M10 x1.5	48	29	61	14	2,990	57
SMGM 12 .50	12	16	12	22.23	15.43	30	M12 x1.75	54	33	69	13	3,800	87
SMGM 14 .50	14	19	13.5	25.40	16.86	34	M14 x2	60	36	77	16	4,690	120
SMGM 16 .50	16	21	15	28.58	19.39	38	M16 x2	66	40	85	15	5,680	170
SMGM 18 .50	18	23	16.5	31.75	21.89	42	M18 x1.5	72	44	93	15	6,770	240



Competition Series SMM..50/51 SMGM..50/51/52

Special features:

- Magnetic fault inspection as standard
- Without play
- High torque

Materials

Mount:

- High tensile steel 34CrNiMo6 (1.6582), blackened, oiled

Bush:

- Bearing steel 100Cr6 (1.3505), hardened, chrome

Spacers:

- Stainless steel X10CrNiS18-9 (1.4305)

Notes

Left-hand thread: add the suffix L in the description

- Example: SMLGM 12.50

By request:

- Original lubricant - Molykote BR2 (see page 17)
- Reduced torque

Series .51

- MF thread

Type	d H7	B $\begin{matrix} 0 \\ -0,05 \end{matrix}$	C ± 0.2	d _k	d ₁	d ₂	d ₃ 6 g	h	l ₁	l ₂	α°	Basic static loading C ₀ (daN)	Weight (g)
SMM 5.51	5	8	6	11.11	7.71	16	M5 x0.5	33	20	41	13	1,290	12
SMM 6.51	6	9	6.75	12.70	8.96	18	M6 x0.75	36	22	45	13	1,550	18
SMGM 8.51	8	12	9	15.88	10.40	22	M8 x1	42	25	53	14	2,290	35
SMGM 10.51	10	14	10.5	19.05	12.92	26	M10 x1	48	29	61	14	2,990	57
SMGM 12.51	12	16	12	22.23	15.43	30	M12 x1.5	54	33	69	13	3,800	87
SMGM 14.51	14	19	13.5	25.40	16.86	34	M14 x1.5	60	36	77	16	4,690	120
SMGM 16.51	16	21	15	28.58	19.39	38	M16 x1.5	66	40	85	15	5,680	170

Series .52

- MF thread and bush bore 2mm smaller than the thread

Type	d H7	B $\begin{matrix} 0 \\ -0,05 \end{matrix}$	C ± 0.2	d _k	d ₁	d ₂	d ₃ 6 g	h	l ₁	l ₂	α°	Basic static loading C ₀ (daN)	Weight (g)
SMGM 10.52	8	14	10.5	19.05	12.92	26	M10 x1	48	29	61	31.5	2,990	57
SMGM 12.52	10	16	12	22.23	15.43	30	M12 x1.5	54	33	69	30.5	3,800	87
SMGM 14.52	12	19	13.5	25.40	16.86	34	M14 x1.5	60	36	77	29.5	4,690	120
SMGM 16.52	14	21	15	28.58	19.39	38	M16 x1.5	66	40	85	29	5,680	170
SMGM 18.52	16	23	16.5	31.75	21.89	42	M18 x1.5	72	44	93	28	6,770	240

Standard series SME/SFE

General mechanics
Self-lubricated

Use

- High stress, maintenance-free applications
- Usual use, general mechanics

Slip contact

- Uniflon® Type E / bearing steel

Maintenance

- Self-lubricated, maintenance-free

Dimensions:

- Available in sizes 3 to 30
- For bore diameters over 30mm. please ask us

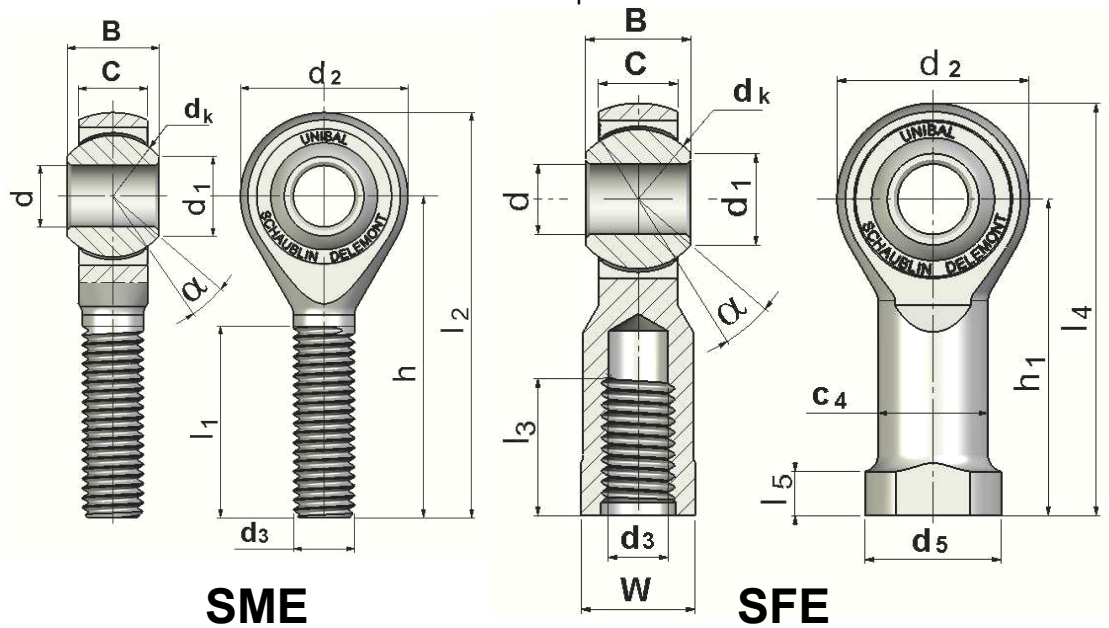

Type		d H7	B 0 - 0,05	C ± 0.2	dk	d1	d2	d3 (SM) 6 g (SF) 6 H
SME 3	SFE 3	3	6	4.5	7.93	5.18	12	M3 x0.5
SME 4	SFE 4	4	7	5.25	9.52	6.46	14	M4 x0.7
SME 5	SFE 5	5	8	6	11.11	7.71	16	M5 x0.8
SME 6	SFE 6	6	9	6.75	12.70	8.96	18	M6 x1
SME 8	SFE 8	8	12	9	15.88	10.40	22	M8 x1.25
SME 10	SFE 10	10	14	10.5	19.05	12.92	26	M10 x1.5
SME 12	SFE 12	12	16	12	22.23	15.43	30	M12 x1.75
SME 14	SFE 14	14	19	13.5	25.40	16.86	34	M14 x2
SME 16	SFE 16	16	21	15	28.58	19.39	38	M16 x2
SME 18	SFE 18	18	23	16.5	31.75	21.89	42	M18 x1.5
SME 20	SFE 20	20	25	18	34.92	24.38	46	M20 x1.5
SME 22	SFE 22	22	28	20	38.10	25.84	50	M22 x1.5
SME 25	SFE 25	25	31	22	42.85	29.60	56	M24 x2
SME 30	SFE 30	30	37	25	50.80	34.80	66	M30 x2



Standard series SME/SFE

General mechanics

Self-lubricated

Special features:

- Made without play

Materials

Mount:

- Size 3 to 12: steel C35Pb (1.0502), zinc chromated blue
- Size 14 to 30: steel C35 (1.0501), zinc chromated blue

Bush:

- Bearing steel 100Cr6 (1.3505), hardened, chrome, sizes 4 to 20

Cage:

- Size 3 to 12: CuZn40MnPb, Uniflon® E self-lubricating fabric
- Size 14 to 30: CuZn40Pb3, Uniflon® E self-lubricating fabric

Notes

Left-hand thread: add the suffix L in the description

- Example: SFLE 6, SMLE 12

By request:

- Produced with special torque
- Magnetic fault inspection (suffix M – Example: SMEM10)
- Produced with special thread

d mm	d ₅	C ₄	h	h ₁	l ₁ ± 0.5	l ₂	l ₃ ± 0.5	l ₄	l ₅	W	α°	Basic static loading C ₀ (daN)	Weight (g)	
													SME	SFE
3	6.5	5.0	27	21	15	33	7.5	27	3	5.5	15	300	5	7
4	8.5	6.5	30	24	18	37	10	31	3.5	7	14	410	9	11
5	9.5	7.5	33	27	20	41	12.5	35	4	8	13	540	12	14
6	12	9.5	36	30	22	45	13	39	5	10	13	700	18	22
8	16	12.5	42	36	25	53	16	47	5	13	14	1,150	35	38
10	19	15.0	48	43	29	61	19	56	6.5	16	14	1,550	57	70
12	22	17.5	54	50	33	69	20	65	6.5	18	13	2,070	87	110
14	25	20.0	60	57	36	77	25	74	8	21	16	2,610	120	150
16	27	22.0	66	64	40	85	30	83	8	24	15	3,220	170	200
18	31	25.0	72	71	44	93	33	92	10	27	15	3,820	240	280
20	34	27.5	78	77	47	101	36	100	10	30	15	4,480	320	370
22	37	30.0	84	84	51	109	40	109	12	34	15	5,310	420	480
25	42	33.5	94	94	57	122	42	122	12	36	15	6,500	580	670
30	50	40.0	110	110	66	143	50	143	15	46	17	8,920	980	1 080

High Tensile Series SME/SFE..40

Self-lubricated

Use

- Application in all fields where static loadings are high, at reduced velocities

Slip contact

- Uniflon® E / Bearing steel bush

Maintenance

- Self-lubricated, maintenance-free

Dimensions:

- Available in sizes 5 to 30
- Please ask us for bore diameters over 30mm

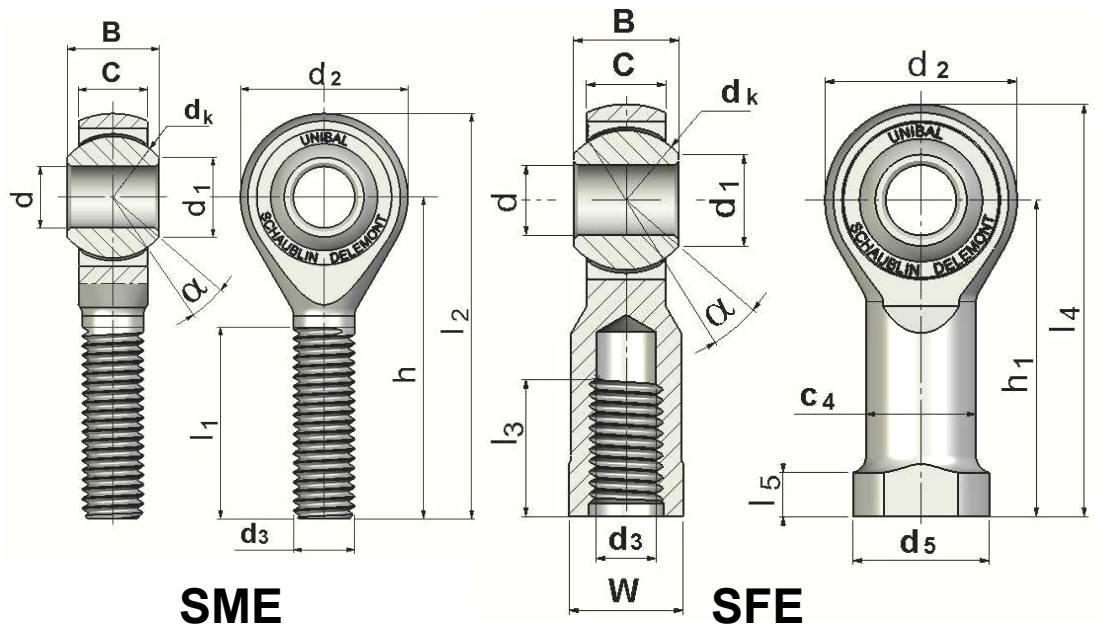

Type		d	B	C	dk	d1	d2	d3
		H7	$\begin{matrix} 0 \\ -0,05 \end{matrix}$	$\pm 0,2$				(SM) 6 g (SF) 6 H
SME 5..40	SFE 5..40	5	8	6	11.11	7.71	16	M5 x0.8
SME 6..40	SFE 6..40	6	9	6.75	12.70	8.96	18	M6 x1
SME 8..40	SFE 8..40	8	12	9	15.88	10.40	22	M8 x1.25
SME 10..40	SFE 10..40	10	14	10.5	19.05	12.92	26	M10 x1.5
SME 12..40	SFE 12..40	12	16	12	22.23	15.43	30	M12 x1.75
SME 14..40	SFE 14..40	14	19	13.5	25.40	16.86	34	M14 x2
SME 16..40	SFE 16..40	16	21	15	28.58	19.39	38	M16 x2
SME 18..40	SFE 18..40	18	23	16.5	31.75	21.89	42	M18 x1.5
SME 20..40	SFE 20..40	20	25	18	34.92	24.38	46	M20 x1.5
SME 22..40	SFE 22..40	22	28	20	38.10	25.84	50	M22 x1.5
SME 25..40	SFE 25..40	25	31	22	42.85	29.60	56	M24 x2
SME 30..40	SFE 30..40	30	37	25	50.80	34.80	66	M30 x2

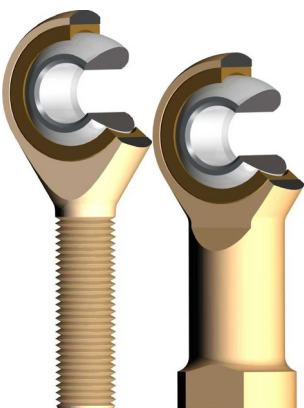

High Tensile Series SME/SFE..40

Self-lubricated

Materials

Mount:

- Steel C45 (1.0503) treated, zinc chromated yellow

Bush:

- Bearing steel 100Cr6 (1.3505), hardened, chrome (size 5 to 20)

Cage:

- Steel C35Pb (1.0502) zinc chromated blue

Notes

Left-hand thread: add the suffix L in the description

- Example: SMLE 12.40

By request:

- Produced with reduced play
- Magnetic fault inspection (suffix M – Example: SMEM12.40)
- Hard chrome plated bush
- Quality or special thread

d mm	d ₅	C ₄	h	h ₁	l ₁ ± 0.5	l ₂	l ₃ ± 0.5	l ₄	l ₅	W	α°	Basic static loading C ₀ (daN)	Weight (g)	
													SME	SFE
5	9.5	7.5	33	27	20	41	12.5	35	4	8	13	690	12	14
6	12	9.5	36	30	22	45	13	39	5	10	13	850	18	22
8	16	12.5	42	36	25	53	16	47	5	13	14	1,330	35	38
10	19	15.0	48	43	29	61	19	56	6.5	16	14	1,790	57	70
12	22	17.5	54	50	33	69	20	65	6.5	18	13	2,390	87	110
14	25	20.0	60	57	36	77	25	74	8	21	16	3,020	120	150
16	27	22.0	66	64	40	85	30	83	8	24	15	3,730	170	200
18	31	25.0	72	71	44	93	33	92	10	27	15	4,420	240	280
20	34	27.5	78	77	47	101	36	100	10	30	15	5,190	320	370
22	37	30.0	84	84	51	109	40	109	12	34	15	6,140	420	480
25	42	33.5	94	94	57	122	42	122	12	36	15	7,530	580	670
30	50	40.0	110	110	66	143	50	143	15	46	17	10,320	980	1080

Stainless Steel Series SME/SFE..45

Use

- Difficult environments, washroom fittings, laboratories, etc...
- Exposure to weather, oxidising and corrosive environments (water, humidity, etc.)

Slip contact

- Uniflon® E / Stainless steel bush

Maintenance

- Maintenance-free

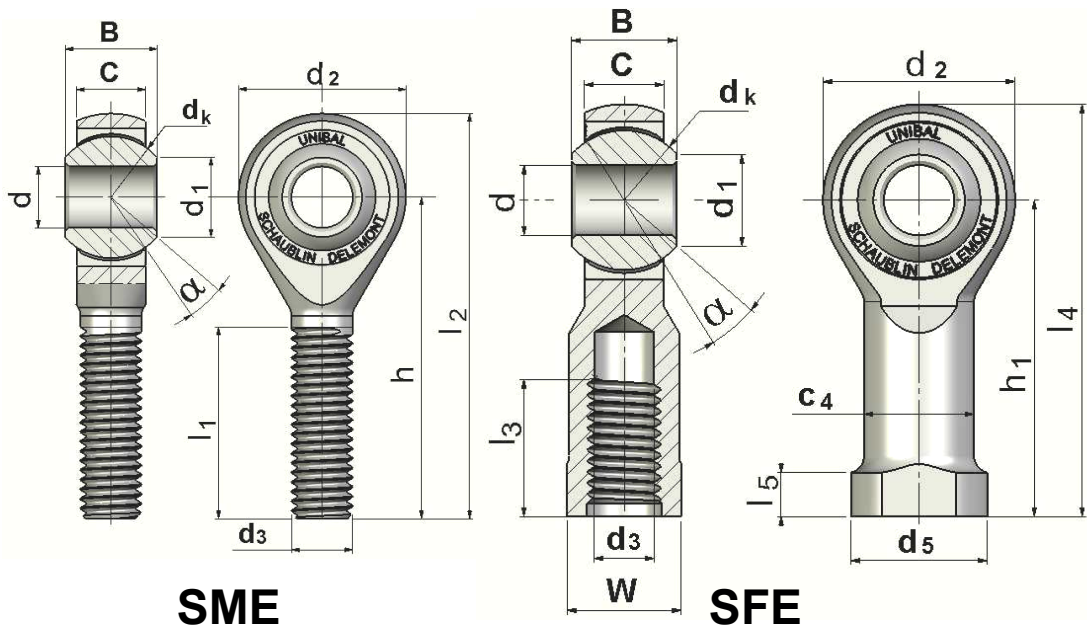

SME

SFE

Type		d H 7	B 0 - 0,05	C ± 0.2	dk	d1	d2	d3 (SM) 6 g (SF) 6 H
SME 3 .45	SFE 3 .45	3	6	4.5	7.93	5.18	12	M3 x0.5
SME 4 .45	SFE 4 .45	4	7	5.25	9.52	6.46	14	M4 x0.7
SME 5 .45	SFE 5 .45	5	8	6	11.11	7.71	16	M5 x0.8
SME 6 .45	SFE 6 .45	6	9	6.75	12.70	8.96	18	M6 x1
SME 8 .45	SFE 8 .45	8	12	9	15.88	10.40	22	M8 x1.25
SME 10 .45	SFE 10 .45	10	14	10.5	19.05	12.92	26	M10 x1.5
SME 12 .45	SFE 12 .45	12	16	12	22.23	15.43	30	M12 x1.75
SME 14 .45	SFE 14 .45	14	19	13.5	25.40	16.86	34	M14 x2
SME 16 .45	SFE 16 .45	16	21	15	28.58	19.39	38	M16 x2
SME 18 .45	SFE 18 .45	18	23	16.5	31.75	21.89	42	M18 x1.5
SME 20 .45	SFE 20 .45	20	25	18	34.92	24.38	46	M20 x1.5
SME 22 .45	SFE 22 .45	22	28	20	38.10	25.84	50	M22 x1.5
SME 25 .45	SFE 25 .45	25	31	22	42.85	29.60	56	M24 x2
SME 30 .45	SFE 30 .45	30	37	25	50.80	34.80	66	M30 x2



Stainless Steel Series SME/SFE..45

Dimensions:

- Available in sizes 3 to 30

Special features:

- Made without play

Materials

Mount:

- Stainless steel X10CrNiS18-9 (1.4305) or X5CrNi18-10 (1.4301)

Bush:

- Stainless steel X46Cr13 (1.4034), hardened

Cage:

- Stainless steel X10CrNiS18-9 (1.4305), Uniflon® E

Notes

Left-hand thread: add the suffix L in the description

- Example: SMLE 12.45

By request:

- Bush stainless steel hard chrome plated
- Other steels

d mm	d ₅	C ₄	h	h ₁	l ₁ ± 0.5	l ₂	l ₃ ± 0.5	l ₄	l ₅	W	α°	Basic static loading C ₀ (daN)	Weight (g)	
													SME	SFE
3	6.5	5.0	27	21	15	33	7.5	27	3	5.5	15	160	5	7
4	8.5	6.5	30	24	18	37	10	31	3.5	7	14	210	9	11
5	9.5	7.5	33	27	20	41	12.5	35	4	8	13	300	12	14
6	12	9.5	36	30	22	45	13	39	5	10	13	380	18	22
8	16	12.5	42	36	25	53	16	47	5	13	14	610	35	38
10	19	15.0	48	43	29	61	19	56	6.5	16	14	810	57	70
12	22	17.5	54	50	33	69	20	65	6.5	18	13	1,090	87	110
14	25	20.0	60	57	36	77	25	74	8	21	16	1,370	120	150
16	27	22.0	66	64	40	85	30	83	8	24	15	1,650	170	200
18	31	25.0	72	71	44	93	33	92	10	27	15	2,010	240	280
20	34	27.5	78	77	47	101	36	100	10	30	15	2,360	320	370
22	37	30.0	84	84	51	109	40	109	12	34	15	2,790	420	480
25	42	33.5	94	94	57	122	42	122	12	36	15	3,400	580	670
30	50	40.0	110	110	66	143	50	143	15	46	17	4,690	980	1080

Competition Series SMEM..50/51/52

Self-lubricated

Use

- Application in all fields where static loadings are high, at reduced velocities

Slip contact

- Uniflon® E / Chrome steel bush

Maintenance

- Self-lubricated, maintenance-free

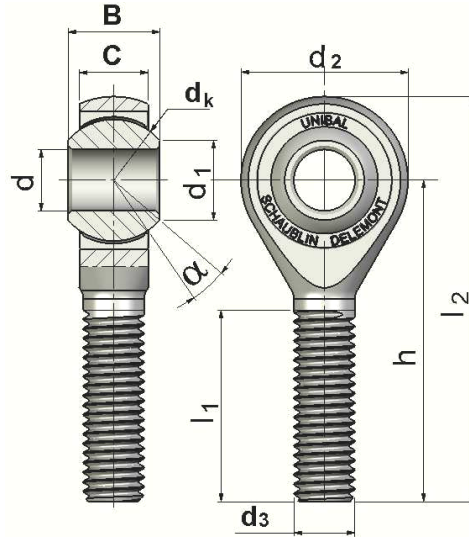

SMEM

Type	d H7	B 0 - 0,05	C ± 0.2	dk	d1	d2	d3 6 g	h	l1	l2	α°	Basic static loading C ₀ (daN)	Weight (g)
SMEM 5 .50	5	8	6	11.11	7.71	16	M5 x0.8	33	20	41	13	1,100	12
SMEM 6 .50	6	9	6.75	12.70	8.96	18	M6 x1	36	22	45	13	1,360	18
SMEM 8 .50	8	12	9	15.88	10.40	22	M8 x1.25	42	25	53	14	2,120	35
SMEM 10 .50	10	14	10.5	19.05	12.92	26	M10 x1.5	48	29	61	14	2,850	57
SMEM 12 .50	12	16	12	22.23	15.43	30	M12 x1.75	54	33	69	13	3,800	87
SMEM 14 .50	14	19	13.5	25.40	16.86	34	M14 x2	60	36	77	16	4,800	120
SMEM 16 .50	16	21	15	28.58	19.39	38	M16 x2	66	40	85	15	5,760	170
SMEM 18 .50	18	23	16.5	31.75	21.89	42	M18 x1.5	72	44	93	15	7,040	240



Competition Series SMEM..50/51/52

Self-lubricated

Special features:

- Magnetic fault inspection as standard
- Without play
- Very high torque

Materials

Mount:

- High tensile steel 34CrNiMo6 (1.6582), blackened, oiled

Bush:

- Bearing steel 100Cr6 (1.3505), hardened, chrome

Cage:

- High tensile steel 34CrNiMo6 (1.6582)
- Uniflon® E

Notes

Left-hand thread: add the suffix L in the description

- Example: SMLEM 12.50

By request:

- Reduced torque

Series .51:

- MF thread

Type	d H7	B 0 - 0,05	C ± 0.2	d _k	d ₁	d ₂	d ₃ 6 g	h	l ₁	l ₂	α°	Basic static loading C ₀ (daN)	Weight (g)
SMEM 5 .51	5	8	6	11.11	7.71	16	M5 x0.5	33	20	41	13	1,100	12
SMEM 6 .51	6	9	6.75	12.70	8.96	18	M6 x0.75	36	22	45	13	1,360	18
SMEM 8 .51	8	12	9	15.88	10.40	22	M8 x1	42	25	53	14	2,120	35
SMEM 10 .51	10	14	10.5	19.05	12.92	26	M10 x1	48	29	61	14	2,850	57
SMEM 12 .51	12	16	12	22.23	15.43	30	M12 x1.5	54	33	69	13	3,800	87
SMEM 14 .51	14	19	13.5	25.40	16.86	34	M14 x1.5	60	36	77	16	4,800	120
SMEM 16 .51	16	21	15	28.58	19.39	38	M16 x1.5	66	40	85	15	5,760	170

Series .52:

Type	d H7	B 0 - 0,05	C ± 0.2	d _k	d ₁	d ₂	d ₃ 6 g	h	l ₁	l ₂	α°	Basic static loading C ₀ (daN)	Weight (g)
SMEM 10 .52	8	14	10.5	19.05	12.92	26	M10 x1	48	29	61	31.5	2,850	57
SMEM 12 .52	10	16	12	22.23	15.43	30	M12 x1.5	54	33	69	30.5	3,800	87
SMEM 14 .52	12	19	13.5	25.40	16.86	34	M14 x1.5	60	36	77	29.5	4,800	120
SMEM 16 .52	14	21	15	28.58	19.39	38	M16 x1.5	66	40	85	29	5,760	170
SMEM 18 .52	16	23	16.5	31.75	21.89	42	M18 x1.5	72	44	93	28	7,040	240

- MF thread and bush bore 2mm smaller than the thread.

Standard series SS

General mechanics

Use

- Usual, standard, general mechanics

Slip contact

- Bronze spacers / Bearing steel bush

Maintenance

- Requires regular lubrication.

Materials

Cage:

- Size 2 to 12: steel C35Pb (1.0502), zinc chromated blue
- Size 14 to 30: steel C35 (1.0501), zinc chromated blue

Bush:

- Bearing steel 100Cr6 (1.3505) hardened, chrome (size 4 to 20)

Spacers:

- Size 2 to 16: CuZn40MnPb
- Size 18 to 30: GC-CuSn7ZnPb

Notes

By request:

- Produced with reduced play
- Magnetic fault inspection (suffix M)
- Original lubricant - Molykote BR2 (see page 17)

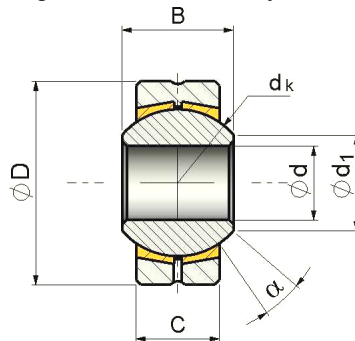

Type	d H7	B ⁰ - 0,05	C ± 0.2	dk	d ₁	D h 6	α°	Basic static loading C ₀ (daN)	Weight (g)
SS 2	2	4.8	3.6	6.00	3.60	9	16	660	3
SS 3	3	6	4.5	7.93	5.18	12	15	1,090	4
SS 4	4	7	5.25	9.52	6.46	14	14	1,530	6
SS 5	5	8	6	11.11	7.71	16	13	2,040	9
SS 6	6	9	6.75	12.70	8.96	18	13	2,620	12
SS 8	8	12	9	15.88	10.40	22	14	4,370	24
SS 10	10	14	10.5	19.05	12.92	26	14	6,120	38
SS 12	12	16	12	22.23	15.43	30	13	8,160	57
SS 14	14	19	13.5	25.40	16.86	34	16	10,490	83
SS 16	16	21	15	28.58	19.39	38	15	13,120	110
SS 18	18	23	16.5	31.75	21.89	42	15	16,030	150
SS 20	20	25	18	34.92	24.38	46	15	19,230	200
SS 22	22	28	20	38.10	25.84	50	15	23,320	250
SS 25	25	31	22	42.85	29.60	56	15	28,850	360
SS 30	30	37	25	50.80	34.80	66	17	38,860	570

Stainless Steel Series SS..45

Use

- Difficult environments, washroom fittings, laboratories, etc....
- Exposure to weather, oxidising and corrosive environments (water, humidity, etc.)

Slip contact

- Bronze spacers / Stainless steel bush

Maintenance

- Requires regular lubrication.

Materials

Cage:

- Stainless steel X10CrNiS18-9 (1.4305) or X5CrNi18-10 (1.4301)

Bush :

- Stainless steel X46Cr13 (1.4034), hardened

Spacers:

- GC-CuSn7ZnPb

Notes

By request:

- Produced with reduced play
- Hard chrome plated stainless steel bush
- Original lubricant - Molykote BR2 (see page 17)
- Made entirely from stainless steel

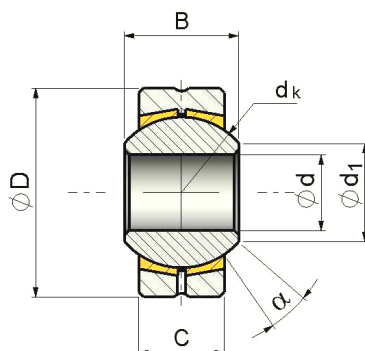

Type	d H7	B 0 - 0,05	C ± 0.2	dk	d ₁	D h6	α°	Basic static loading C ₀ (daN)	Weight (g)
SS 2 .45	2	4.8	3.6	6.00	3.60	9	16	370	3
SS 3 .45	3	6	4.5	7.93	5.18	12	15	610	4
SS 4 .45	4	7	5.25	9.52	6.46	14	14	850	6
SS 5 .45	5	8	6	11.11	7.71	16	13	1,130	9
SS 6 .45	6	9	6.75	12.70	8.96	18	13	1,460	12
SS 8 .45	8	12	9	15.88	10.40	22	14	2,430	24
SS 10 .45	10	14	10.5	19.05	12.92	26	14	3,400	38
SS 12 .45	12	16	12	22.23	15.43	30	13	4,530	57
SS 14 .45	14	19	13.5	25.40	16.86	34	16	5,830	83
SS 16 .45	16	21	15	28.58	19.39	38	15	7,290	110
SS 18 .45	18	23	16.5	31.75	21.89	42	15	8,910	150
SS 20 .45	20	25	18	34.92	24.38	46	15	10,690	200
SS 22 .45	22	28	20	38.10	25.84	50	15	12,950	250
SS 25 .45	25	31	22	42.85	29.60	56	15	16,030	360
SS 30 .45	30	37	25	50.80	34.80	66	17	21,590	570



Standard series SSA

Use

- High stress applications, impacts, vibrations

Slip contact

- Standard series: Steel / Bearing steel

Maintenance

- Lubrication should be liberal

Materials

Cage:

- Size 2 to 16: steel C35Pb (1.0502), zinc chromated blue
- Size 18 to 50: steel Ck35 (1.1181), zinc chromated blue

Bush:

- Bearing steel 100Cr6 (1.3505), hardened, chrome (size 4 to 20)
- If you also want a chromed bush on the sizes larger than 18, add the suffix .10. Example: SSA 22.10. This gives your part an admissible slip velocity higher than the SSA 22 standard version.

Notes

By request:

- Produced with reduced play
- Original lubricant - Molykote BR2 (see page 17)

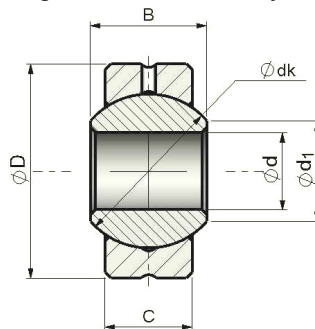

Type	d H7	B 0 - 0,05	C ± 0.2	dk	d ₁	D h 6	α°	Basic static loading C ₀ (daN)	Weight (g)
SSA 2	2	4.8	3.6	6.00	3.60	9	16	660	3
SSA 3	3	6	4.5	7.93	5.18	12	15	1,090	4
SSA 4	4	7	5.25	9.52	6.46	14	14	1,530	6
SSA 5	5	8	6	11.11	7.71	16	13	2,040	9
SSA 6	6	9	6.75	12.70	8.96	18	13	2,620	12
SSA 8	8	12	9	15.88	10.40	22	14	4,370	24
SSA 10	10	14	10.5	19.05	12.92	26	14	6,120	38
SSA 12	12	16	12	22.23	15.43	30	13	8,160	57
SSA 14	14	19	13.5	25.40	16.86	34	16	10,490	83
SSA 16	16	21	15	28.58	19.39	38	15	13,120	110
SSA 18	18	23	16.5	31.75	21.89	42	15	14,700	150
SSA 20	20	25	18	34.92	24.38	46	15	17,630	200
SSA 22	22	28	20	38.10	25.84	50	15	21,370	250
SSA 25	25	31	22	42.85	29.60	56	15	26,450	360
SSA 30	30	37	25	50.80	34.80	66	17	35,600	570

Stainless Steel Series SSA..45

Use

- High stress applications, impacts, vibrations

Slip contact

- Stainless steel / Stainless steel

Maintenance

- Lubrication should be liberal

Materials

Cage:

- Stainless steel X10CrNiS18-9 (1.4305) or X5CrNi18-10 (1.4301)

Bush:

- Stainless steel X46Cr13 (1.4034), hardened

Notes

By request:

- Produced with reduced play
- Original lubricant - Molykote BR2 (see page 17)
- Hard chrome plated stainless steel bush
- Other steels

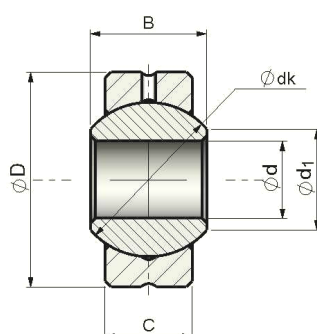

Type	d H7	B 0 - 0,05	C ± 0.2	dk	d ₁	D h 6	α°	Basic static loading C ₀ (daN)	Weight (g)
SSA 3 .45	3	6	4.5	7.93	5.18	12	15	610	4
SSA 4 .45	4	7	5.25	9.52	6.46	14	14	850	6
SSA 5 .45	5	8	6	11.11	7.71	16	13	1,130	9
SSA 6 .45	6	9	6.75	12.70	8.96	18	13	1,460	12
SSA 8 .45	8	12	9	15.88	10.40	22	14	2,430	24
SSA 10 .45	10	14	10.5	19.05	12.92	26	14	3,400	38
SSA 12 .45	12	16	12	22.23	15.43	30	13	4,530	57
SSA 14 .45	14	19	13.5	25.40	16.86	34	16	5,830	83
SSA 16 .45	16	21	15	28.58	19.39	38	15	7,290	110
SSA 18 .45	18	23	16.5	31.75	21.89	42	15	8,910	150
SSA 20 .45	20	25	18	34.92	24.38	46	15	10,690	200
SSA 22 .45	22	28	20	38.10	25.84	50	15	12,950	250
SSA 25 .45	25	31	22	42.85	29.60	56	15	16,030	360
SSA 30 .45	30	37	25	50.80	34.80	66	17	21,590	570

Competition Series SSA..50

Use

- High stress applications, impacts, vibrations
- Combined stresses, high static and dynamic loadings

Slip contact

- Steel cage / Chrome steel bush

Maintenance

- Lubrication should be liberal

Special features

- Made without play
- Very high torque

Materials

Cage:

- High tensile steel 45S20 (1.0727), zinc chromated yellow

Bush:

- Bearing steel 100Cr6 (1.3505), hardened, chrome

Notes

By request:

- Magnetic fault inspection (suffix M)
- Original lubricant - Molykote BR2 (see page 17)
- Reduced torque

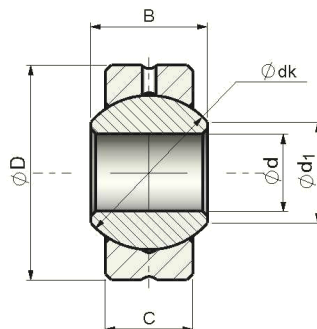

Type	d H7	B 0 - 0,05	C ± 0.2	dk	d ₁	D	α°	Basic static loading C ₀ (daN)	Weight (g)
SSA 3.50	3	6	4.5	7.93	5.18	12	15	2,100	4
SSA 5.50	5	8	6	11.11	7.71	16	13	3,920	9
SSA 6.50	6	9	6.75	12.70	8.96	18	13	5,040	12
SSA 8.50	8	12	9	15.88	10.40	22	14	8,410	24
SSA 10.50	10	14	10.5	19.05	12.92	26	14	11,770	38
SSA 12.50	12	16	12	22.23	15.43	30	13	15,690	57
SSA 14.50	14	19	13.5	25.40	16.86	34	16	20,170	83
SSA 16.50	16	21	15	28.58	19.39	38	15	25,220	110
SSA 18.50	18	23	16.5	31.75	21.89	42	15	30,810	150
SSA 20.50	20	25	18	34.92	24.38	46	15	36,970	200
SSA 22.50	22	28	20	38.10	25.84	50	15	44,820	250

Standard series SSE

General mechanics

Self-lubricated

Use

- High stress, maintenance-free applications
- Use usual, general mechanics

Slip contact

- Uniflon® Type E / chrome steel bearing

Maintenance

- Self-lubricated, maintenance-free

Materials

Cage:

- Size 3 to 12: steel C35Pb (1.0502), zinc chromated blue
- Size 14 to 30: steel C35 (1.0501), zinc chromated blue

Bush:

- Bearing steel 100Cr6 (1.3505), hardened, chrome, sizes 4 to 20

Notes

By request:

- Produced with special torque
- Magnetic fault inspection (suffix M – Example: SSEM10)

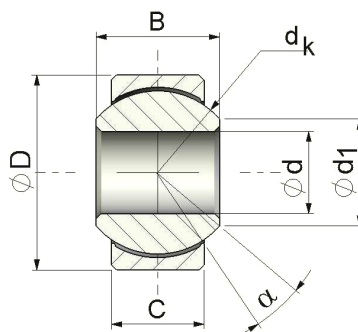

Type	d H7	B ⁰ - 0,05	C ± 0.2	dk	d ₁	D h 6	α°	Basic static loading C ₀ (daN)	Weight (g)
SSE 3	3	6	4.5	7.93	5.18	12	15	1,090	4
SSE 4	4	7	5.25	9.52	6.46	14	14	1,530	6
SSE 5	5	8	6	11.11	7.71	16	13	2,040	9
SSE 6	6	9	6.75	12.70	8.96	18	13	2,620	12
SSE 8	8	12	9	15.88	10.40	22	14	4,370	24
SSE 10	10	14	10.5	19.05	12.92	26	14	6,120	38
SSE 12	12	16	12	22.23	15.43	30	13	8,160	57
SSE 14	14	19	13.5	25.40	16.86	34	16	10,490	83
SSE 16	16	21	15	28.58	19.39	38	15	13,120	110
SSE 18	18	23	16.5	31.75	21.89	42	15	14,700	150
SSE 20	20	25	18	34.92	24.38	46	15	17,630	200
SSE 22	22	28	20	38.10	25.84	50	15	21,370	250
SSE 25	25	31	22	42.85	29.60	56	15	26,450	360
SSE 30	30	37	25	50.80	34.80	66	17	35,600	570



Stainless Steel Series SSE..45

Use

- Difficult environments, washroom fittings, laboratories, etc...
- Exposure to weather, oxidising and corrosive environments (water, humidity, etc.)

Slip contact

- Uniflon® E / Stainless steel bush

Maintenance

- Maintenance-free

Materials

Cage:

- Stainless steel X10CrNiS18-9 (1.4305)
- Uniflon® E

Bush :

- Stainless steel X46Cr13 (1.4034), hardened

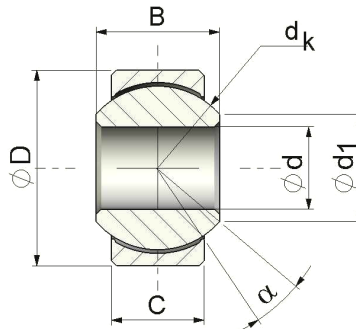

Type	d H7	B ⁰ - 0,05	C ± 0.2	d _k	d ₁	D h 6	α°	Basic static loading C ₀ (daN)	Weight (g)
SSE 3 .45	3	6	4.5	7.93	5.18	12	15	610	4
SSE 4 .45	4	7	5.25	9.52	6.46	14	14	850	6
SSE 5 .45	5	8	6	11.11	7.71	16	13	1,130	9
SSE 6 .45	6	9	6.75	12.70	8.96	18	13	1,460	12
SSE 8 .45	8	12	9	15.88	10.40	22	14	2,430	24
SSE 10 .45	10	14	10.5	19.05	12.92	26	14	3,400	38
SSE 12 .45	12	16	12	22.23	15.43	30	13	4,530	57
SSE 14 .45	14	19	13.5	25.40	16.86	34	16	5,830	83
SSE 16 .45	16	21	15	28.58	19.39	38	15	7,290	110
SSE 18 .45	18	23	16.5	31.75	21.89	42	15	8,910	150
SSE 20 .45	20	25	18	34.92	24.38	46	15	10,690	200
SSE 22 .45	22	28	20	38.10	25.84	50	15	12,950	250
SSE 25 .45	25	31	22	42.85	29.60	56	15	16,030	360
SSE 30 .45	30	37	25	50.80	34.80	66	17	21,590	570

Competition Series SSE..50

Use

- High stress applications, impacts, vibrations
- Combined stresses, high static and dynamic loadings

Slip contact

- Uniflon® E / Bush chrome steel

Maintenance

- Self-lubricated, maintenance-free

Special features

- Made without play
- Very high torque

Materials

Cage:

- High tensile steel 45S20 (1.0727), zinc chromated yellow
- Uniflon® E

Bush :

- Bearing steel 100Cr6 (1.3505), hardened, chrome

Notes

By request:

- Magnetic fault inspection (suffix M)
- Reduced torque

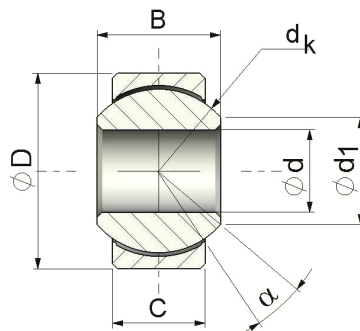

Type	d H7	B 0 - 0,05	C ± 0.2	dk	d ₁	D h 6	α°	Basic static loading C ₀ (daN)	Weight (g)
SSE 5 .50	5	8	6	11.11	7.71	16	13	3,920	9
SSE 6 .50	6	9	6.75	12.70	8.96	18	13	5,040	12
SSE 8 .50	8	12	9	15.88	10.40	22	14	8,410	24
SSE 10 .50	10	14	10.5	19.05	12.92	26	14	11,770	38
SSE 12 .50	12	16	12	22.23	15.43	30	13	15,690	57
SSE 14 .50	14	19	13.5	25.40	16.86	34	16	20,170	83
SSE 16 .50	16	21	15	28.58	19.39	38	15	25,220	110
SSE 18 .50	18	23	16.5	31.75	21.89	42	15	30,810	150
SSE 20 .50	20	25	18	34.92	24.38	46	15	36,970	200
SSE 22 .50	22	28	20	38.10	25.84	50	15	44,820	250



Basic application data to be provided to calculate life

By request, we are able to make a complete calculation. The calculation formulas used are given in the calculation chapter. You can complete and return this questionnaire.

- Provide as much data as possible
- Provide an explanatory sketch of the application if necessary
- State the mean stresses operating in your system

Complete the information in the following sections:

1. Size wanted (diameter of the bore):
2. Type of spherical bearing wanted:
3. Life wanted: hours
4. Static loadings: yes / no
5. Dynamic loadings: yes / no
6. Type of loadings:
7. Change of direction of loadings
(alternating or pulsating loadings): /min
8. Radial loadings: daN
9. Axial loadings: daN
10. Impacts: yes / no
11. Estimated violence of impacts: daN
12. Significant vibrations: yes / no
13. Frequency of vibrations: osc./min
14. Complete rotation: yes / non
15. Angle of oscillation: Rotation (±) °
16. Angle of oscillation: Tilt (±) °
17. Frequency: osc./min
18. Ambient temperature: °C
19. Maintenance, lubrication:
20. Frequency of maintenance: hours
21. Rotation torque wanted: daNm
22. Particular environment: yes / no
23. External influence: yes / no
24. Kind of external influences:

25. Other features:

26. Description of use: