

Model VRT Miniature Type (Tapped Base Type)

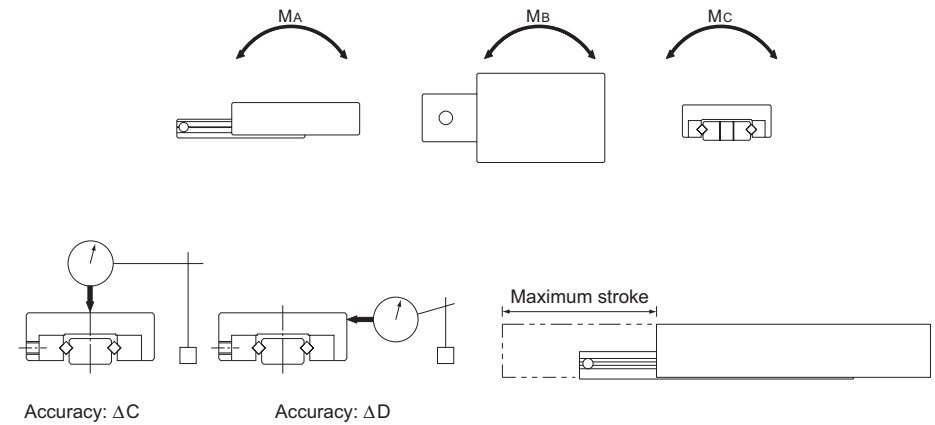
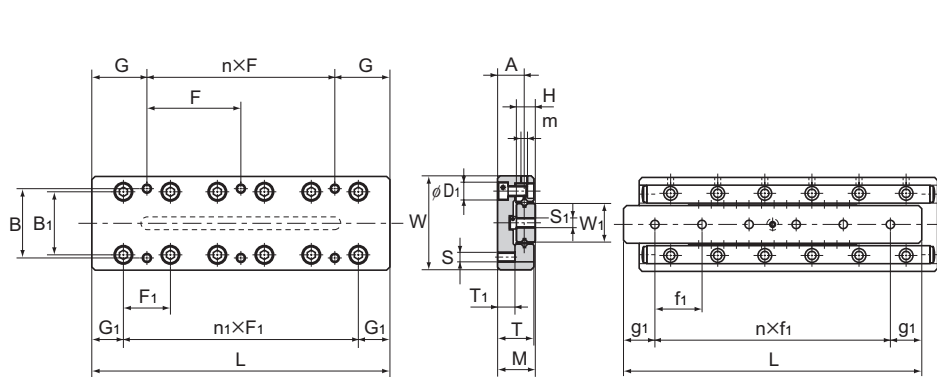

Unit: mm

Model No.	Main dimensions					Table surface dimensions							Side surface dimensions						Base surface dimensions Mounting hole position			Basic load rating			Static permissible moment			Accuracy μm			
	Maximum stroke	Width W ±0.1	Height M ±0.1	Length L	Mass g	Table mounting tap position				n ₁ × F ₁	B ₁	D ₁	G ₁	T	T ₁	H	W ₁	A	m	S ₁	n × f ₁	g ₁	No. of rollers Z	C kN	C ₀ kN	M _A N-m	M _B N-m	M _C N-m	ΔC	ΔD	
						B	n × F	G	S																						
VRT 1025	12	20	8	25	23	14	1 × 18	3.5	M2.6	1 × 10	12.4	4.1	7.5	3.5	4	6.7	5.5	M2.6	2 × 7.5	5	5	0.28	0.27	0.75	0.46	0.69	4	4			
VRT 1035	18			35	32		1 × 28	3.5														2 × 10	7	0.38	0.41	1.23			0.85	1.03	
VRT 1045	25			45	42		1 × 20	12.5														3 × 10	10	0.56	0.69	2.18			1.67	1.72	
VRT 1055	32			55	52		1 × 30	12.5														4 × 10	12	0.65	0.82	2.97			2.35	2.06	
VRT 1065	40			65	62		2 × 20	12.5														5 × 10	14	0.73	0.96	3.87			3.17	2.4	
VRT 1075	45			75	72		1 × 30	22.5														6 × 10	18	0.87	1.27	6.05			5.16	3.19	
VRT 1085	50			85	82		2 × 30	12.5														7 × 10	20	0.94	1.37	7.32			6.37	3.43	
VRT 2035	18	30	12	35	78	22	1 × 28	3.5	M3	1 × 15	20	6	10	5.5	6	12.2	8.5	M2	M3	1 × 20	5	7	0.51	0.51	2.29	1.37	2.21	2	4		
VRT 2050	30			50	113		1 × 43	3.5															2 × 15	7	0.69	0.76	3.76			2.65	3.32
VRT 2065	40			65	147		1 × 30	17.5															3 × 15	9	0.85	0.98	5.62			4.22	4.25
VRT 2080	50			80	184		1 × 45	17.5															4 × 15	12	0.98	1.27	9.1			7.26	5.52
VRT 2095	60			95	220		2 × 30	17.5															5 × 15	14	1.18	1.57	11.8			9.71	6.8
VRT 2110	70			110	257		1 × 45	32.5															6 × 15	17	1.47	2.06	16.7			14.1	8.93
VRT 2125	80			125	290		2 × 45	17.5															7 × 15	19	1.57	2.25	20.4			17.5	9.77
VRT 3055	30	40	16	55	229	30	1 × 40	7.5	M4	1 × 25	28.4	7.5	15	7.5	8	16	11.5	M4	1 × 35	6	10	1.27	1.37	9.85	6.57	7.97	3	6			
VRT 3080	45			80	336		1 × 65	7.5														2 × 25	10	2.16	2.84	22.2			17	16.5	
VRT 3105	60			105	442		1 × 50	27.5														3 × 25	13	2.94	4.22	34.8			28.1	24.4	
VRT 3130	75			130	551		1 × 75	27.5														4 × 25	17	3.63	5.69	55.8			47.1	33.3	
VRT 3155	90			155	657		2 × 50	27.5														5 × 25	20	3.92	6.37	74.7			64.6	36.9	
VRT 3180	105			180	766		1 × 75	52.5														6 × 25	24	4.02	6.57	104			92.3	38.1	
VRT 3205	130			205	871		2 × 75	27.5														7 × 25	26	4.22	7.16	120			107	41.5	

Note) All stainless steel type with high corrosion resistance is also available.

(Example) VRT 2035 M

Symbol for stainless steel type

Cross Roller Table