

# BALL & LEAD SCREWS

**THOMSON™**



*Ball & Lead Screw  
Products of Ball Screws  
and Actuators (BSA) and  
Warner Linear are now*  
**THOMSON™**

**February 2004 Release**

1-800-554-8466  
[www.ball screws.com](http://www.ball screws.com)

**DANAHER**  
MOTION  
Solutions by

# Mechanical and Electro-Mechanical Product Solutions by Danaher Motion

Danaher Motion engineers, manufactures and markets a select combination of the world's top brands of mechanical and electro-mechanical products. Our principle brands and products include:

- **THOMSON** industrial, precision and rodless actuators, linear slide tables and systems, ball and lead screws, linear bearings and guides, precision balls, shafting and integrated solutions
- **MICRON** gearheads
- **DELTRAN PT** electromagnetic friction and wrap spring clutches and brakes
- **SUPERIOR ELECTRIC** stepper and servo motors and controls
- **SECO AC and DC** variable speed drives

Designed to help increase productivity and improve performance, our products are incorporated into new equipment designs as well as machines already in service. From semiconductor assembly, packaging, robotics and industrial automation to medical, fitness and mobile off-highway equipment, our mechanical and electro-mechanical products bring flexibility, precision, efficiency, and reliability to a wide variety of industries.

Beyond our world-class product designs, one of our greatest strengths is our commitment to Danaher Business System (DBS), which is comprised of a unique set of robust, repeatable processes that help us constantly improve the operational efficiency of our factories. Based upon the time-tested methods of Kaizen, the DBS is a team-based mindset that continuously and aggressively eliminates waste in every facet of our business operations. Furthermore, the DBS focuses the entire organization on breakthrough objectives that culminate in maintainable, results-oriented business processes, which, in turn, create advantages for our customers in the areas of quality, delivery and performance.

At Danaher Motion, we bring together best-in-class products, unsurpassed customization expertise, and innovative solutions to significantly improve and revolutionize the way things move. We are the experts in motion control. In short, Danaher Motion offers more choices, more application expertise and more integrated solutions than anyone else in the market

Website: [www.DanaherLinear.com](http://www.DanaherLinear.com)

**THOMSON**

**MICRON**

**Deltran PT**

**Superior  
Electric**

**Seco**  
AC/DC Drives

## A World Class Heritage Serves as Our Foundation

Danaher Motion has a long history of manufacturing quality lead screws and ball screws. Our roots are planted in three separate companies that held strong and definitive footholds in the market. Those companies—Ball Screws & Actuators Co., Inc. (BSA), Warner Linear, and Thomson Industries –now form the nucleus of Danaher Motion’s ball screw and lead screw business.

Founded in 1971, the Ball Screws & Actuators Co. was a pioneer and leader in precision plastic nut, lead screw and ball screw technologies for linear motion applications. Their custom and off-the-shelf solutions featured many patented products, including their ActiveCAM technology for eliminating backlash while increasing performance and wear life. BSA joined Danaher Motion in 1996 and brought a wealth of experience and knowledge to the ball and lead screw team.

Tollo Linear was founded in 1982 and manufactured linear actuators, linear drive units and handling components under a variety of trademarked product names. Its products were sold to direct customers, OEM manufacturers, and system houses throughout the world. In 1989, Tollo Linear was purchased by Warner Electric and the new division became known as Warner Linear. After substantial growth in the industry, Warner Linear, including its superior ball screw product line, was acquired by Danaher Motion in 2000.

Thomson Industries was a leading U.S. producer of linear motion control products, including linear actuators, ball screws, linear bearings and rails, and precision gearboxes. Its products were found in a range of precision motion applications in the medical, industrial, aerospace and mobile off-highway markets. In October 2002, Danaher Motion acquired Thomson Industries and retained the strong Thomson brand name.

The current lead screw and ball screw offerings of Danaher Motion combine the quality, strength and expertise of the distinct products and professionals at these three companies under the Thomson brand. The products set the solid foundation for the broad range of standard and custom lead and ball screws currently available. If past history and experience is an indication of what the future holds, Danaher Motion is significantly poised to remain a prominent leader and pioneer in the ball screw and lead screw industry.

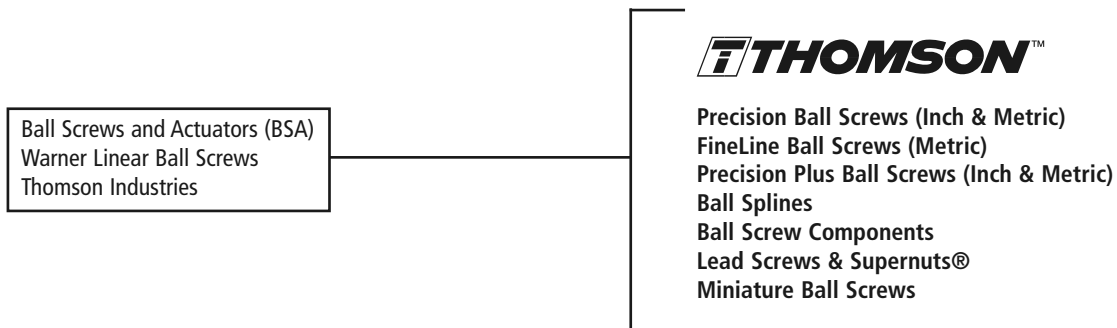

Products formerly under the Ball Screws & Actuators (BSA) brand can be found on pages 13-42.

Products formerly under the Warner Linear brand can be found in the Ball Screw & Ball Splines section page 90.

Products formerly under the Thomson Industries brand can be found in the Ball Screw & Ball Splines section page 43 & 140.

Company Overview .....	3
Product Overview .....	5
Application Analysis Worksheet .....	6
Technology Comparison .....	8
Applications .....	10
Custom Capabilities .....	12

## LEAD SCREWS AND SUPERNUTS® AND MINIATURE BALL SCREWS

### LEAD SCREWS AND SUPERNUTS®

Product Selection .....	13
Engineering Guidelines .....	14

### MINIATURE BALL SCREWS

Product Overview .....	39
------------------------	----

## BALL SCREWS, BALL SPLINES AND COMPONENTS

### INCH BALL SCREWS

Product Selection .....	43
Engineering Guidelines .....	47

#### Precision Ball Screw

Product Availability .....	58
Engineering Guidelines .....	59
Components .....	61

#### Precision Plus Ball Screw

Product Availability .....	92
Engineering Guidelines .....	93
Components .....	96
Quick Mount* Bearing Block .....	103

### METRIC BALL SCREWS

Product Selection .....	106
Engineering Guidelines .....	107

#### Precision Ball Screw

Product Availability .....	107
Engineering Guidelines .....	116

#### FineLine Ball Screw

Product Availability .....	124
Engineering Guidelines .....	125
Components .....	129

#### Precision Plus Ball Screw

Product Availability .....	132
Engineering Guidelines .....	133
Components .....	135
Quick Mount* Bearing Block .....	137

### THOMSON PRECISION BALL SPLINES

Product Availability .....	140
Engineering Guidelines .....	141

Lubrication .....	147
-------------------	-----

Maintenance & Service .....	148
-----------------------------	-----

Repair .....	153
--------------	-----

Glossary .....	154
----------------	-----

Useful Formulas .....	156
-----------------------	-----

## PRECISION LEAD SCREWS, SUPERNUTS®, AND MINIATURE BALL SCREWS

Offering smooth, precise, cost effective positioning, this is the "just right" solution for your application. Thomson precision lead screws are an excellent economical solution for your linear motion requirements. Our precision rolling machines ensure accurate positioning to 0.003 in/ft and our PTFE coating process produces assemblies that have less drag torque and last longer. Danaher Motion provides a large array of standard plastic nut assemblies in anti-backlash or standard Supernut designs. For significantly higher loads, standard bronze nuts are available. Danaher Motion also provides engineering design services to aid in your custom design requirements producing a lead screw assembly to your specifications. Available from over 1800 distributors worldwide.

### Features

- "Just right" solution
- High design flexibility
- Standard and anti-backlash nuts
- Stainless steel and polymer construction
- 0.003"/ft lead accuracies
- Medical equipment, semiconductor equipment, and consumer electronics



## THOMSON PRECISION BALL SCREWS

Full range of diameters, leads, and ball nut configurations.

Thomson precision ball screws come in a full range of diameters, leads, and ball nut configurations, in either preloaded or non-preloaded types, all in industry-standard envelopes. They provide dependable accuracy and repeatability at an economical price. Precision ball screws operate at over 90% efficiency with a constant low coefficient of friction. Precision ball nuts feature a Gothic arch ball groove geometry that extends service life, reduces lash, and optimizes stiffness in preloaded assemblies. This unique design also eliminates skidding, increases positioning accuracy, and maximizes travel life. Optional wiper kits and end support blocks are available, which increase system efficiency and service life. Available from over 1800 distributors worldwide.

### Features

- Full range of diameters, leads, and nuts
- High efficiency (> 90%)
- Gothic arch design
- Optional wiper kits and end support blocks
- Factory automation, automotive, medical, nuclear fuel handling, aerospace



INCH

METRIC

## THOMSON FINELINE BALL SCREWS

Outstanding precision at an affordable price.

Thomson's patented, German-engineered Precision Screw Forming (PSF) Technology has created a higher performing ball screw, combining outstanding precision – traditionally associated with ground screws – with the manufacturing efficiency of rolled processes. The result is an affordable ball screw with highest precision and outstanding performance. Thomson FineLine ball screws are equal in accuracy and performance to ground screws of the same accuracy class, but with harder grain structures, lower cost, and short manufacturing lead times. PSF Technology consistently produces screws with accuracies ranging up to 24µm/300mm (0.001 in/foot). Available from over 1800 distributors worldwide.

### Features

- Available in ISO accuracy grades P3 and P5
- Quiet operation
- Consistent running torque
- Preloads zero to 13% of dynamic load rating
- Factory automation, automotive, and medical



## THOMSON PRECISION PLUS BALL SCREWS

High precision and accuracy for today's most stringent positioning requirements.

Precision Plus\* ball screw assemblies give you at least eight times the lead accuracy of conventional rolled-thread units, for immediate improvement in machine performance. Standard sizes and leads with accuracies of .0005 in./ft. are available. A temperature-controlled grinding and laser inspection area ensures the highest quality and performance levels. Precision Plus ball screw assemblies offer zero-lash, high spring rate positioning and repeatability for machine tools, robots, material handling systems, electronic component insertion systems, and more. Available from over 1800 distributors worldwide.

### Features

- Eight times the lead accuracy of Precision ball screws
- Zero lash, high spring rate preloaded design
- High efficiency (>90%)
- Gothic arch design
- Machine tools, robots, material handling systems, electronic component insertion systems



INCH

METRIC

## THOMSON PRECISION BALL SPLINES

High reliability, speed and versatility for tough applications with torque loads.

Thomson precision ball spline systems feature high speed, anti-friction linear motion under high torsional loads. They have high reliability under varying operating conditions and predictable life expectancy. They resist radial displacement resulting from torque loads, and require smaller forces to achieve axial displacement of the spline member while transmitting torque. Ball splines have application versatility such as helicopter rotor couplings; translating drive shaft couplings, non-swiveling telescoping struts; honing machine and drill press spindles, workhead and table ways, and remote and robot handling machines. Available from over 1800 distributors worldwide.

### Features

- High speed, anti-friction linear motion under high torsional loads
- 0.375" to 6.000" diameter
- Up to 584,000 in-lbs static torque load
- Helicopter rotor coupling, translating drive shaft coupling, non-swiveling telescoping struts, honing machine and drill press spindles, workhead and table ways, robots and remote handling machines.

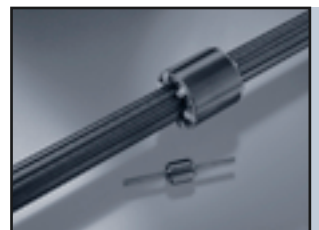

## MAINTENANCE & SERVICE

Maximum life and trouble-free operation.

All Thomson ball screw assemblies are designed for maximum life and trouble free operation when adequately serviced and maintained. This section provides detailed instructions on ball screw operation, troubleshooting, inspection techniques, lubrication, disassembly and reassembly. For more detailed information contact our factory to speak to one of our experts, 1-800-554-8466.

## REPAIR

Expert ball screw reconditioning for any design or make.

When a ball screw assembly wears, replacement may not be the only solution to the problem. Reconditioning can save up to 90% of the cost of a new ball screw assembly. Worn or damaged ball screws of any design and from any manufacturer can normally be restored to their original performance specifications. Internal and external return systems are refurbished. Screws and nuts are remanufactured. If bearing journals are undersized, scored, or damaged, surface build up and expert regrinding can bring the assembly back to original specification. When an evaluation identifies a problem with your application, a new ball screw assembly can be redesigned and manufactured, if desired. For more detailed information contact our factory to speak to one of our experts, 1-800-554-8466.



## Application Data Information Sheet

Fax: Ball Screw: 989-776-0103  
Lead Screw: 408-629-2620

E-mail: Ball Screw: ballscrews@danahermotion.com  
Lead Screw: leadscrews@danahermotion.com

Name: \_\_\_\_\_

Title/Dept. \_\_\_\_\_

Company Name: \_\_\_\_\_

Address: \_\_\_\_\_

\_\_\_\_\_

Phone: \_\_\_\_\_ Fax: \_\_\_\_\_

E-mail: \_\_\_\_\_

1. What is your LOAD? \_\_\_\_\_  
 Pounds    Kilograms    Newtons  
 Other \_\_\_\_\_  
(please describe)
2. Is your MOTION    Horizontal   or    Vertical
3. What is the length of STROKE? \_\_\_\_\_  
 Inch    Foot    mm  
 Other \_\_\_\_\_  
(please describe )
4. What is the SPEED? \_\_\_\_\_  
 Inch    Foot    mm   per    second    minute  
 Other \_\_\_\_\_  
(please describe)
5. ACCURACY requirements :  
 0.005"/foot    0.0005"/foot  
 0.003"/foot    Other \_\_\_\_\_  
(please describe )
6. BACKLASH requirements:  
 0"    .010"  
 0.002 "    Other \_\_\_\_\_  
(please describe )
7. BEARING SUPPORT requirements:  
 Fixed/Simple    Fixed Free  
 Fixed/Fixed    Other \_\_\_\_\_  
(please describe )
8. MOTOR CUBE requirements:  
 NEMA 17    NEMA 42  
 NEMA 23    Other \_\_\_\_\_  
 NEMA 34   (please describe)
9. Quantity required \_\_\_\_\_ per  
 Month    Year    Other

Additional information/comments:

### Application Data Information Sheet (continued)

#### 10. Assemblies: Part Number

Quantity \_\_\_\_\_ Lead Error – in./ft. (circle) Standard .004 .0005 Special .002 .001 .0002  
Diameter \_\_\_\_\_ Lead \_\_\_\_\_ Part Number \_\_\_\_\_ Overall Length \_\_\_\_\_

#### 11. End Blocks (end blocks require Type III machined ends)

Quantity Per Assembly (1 or 2) \_\_\_\_\_ End Block Part Number \_\_\_\_\_

#### 12. End Machining

Right End – standard end machining  
 Types (circle one) I II III\* IV  
 with drive  
 without drive

\* Type III end machining required for end blocks

Left End – standard end machining  
 Types (circle one) I II III\* IV  
 with drive  
 without drive

\* Type III end machining required for end blocks

- Cut to length only
- Other (see attached print)

Ball Nut Part Number \_\_\_\_\_ Flange Part Number \_\_\_\_\_ Wiper Part Number \_\_\_\_\_

#### 13. Ball Nut Flange or V-thread to Face

- Left end machining
- Right end machining
- Other (see attached print)

#### Flange Flats

- Yes (see attached print)
- No

Purchase order number \_\_\_\_\_ Requested delivery date \_\_\_\_\_

Shipping instructions \_\_\_\_\_

Signature (required for orders) \_\_\_\_\_

FAX THIS FORM TO:  
Ball Screw: 989-776-0103 • Lead Screw: 408-629-2620

OR E-MAIL:  
Ball Screw: ballscrews@danahermotion.com • Lead Screw: leadscrews@danahermotion.com



\* Trademark of Danaher Motion. DANAHER MOTION is registered in the U.S. Patent and Trademark Office and in other countries.

## Thomson Ball Screws and Lead Screws Are Your Best Choice for Linear Actuation

Thomson ball screws outperform other actuation methods.

Compared to bulky, noisy, and expensive hydraulic or pneumatic actuator systems, Thomson ball screws and lead screws are compact, quiet, and very affordable. In addition, there's no need for pumps, hoses, fluids, or shop air. This eliminates fire, safety, and health hazards due to leaking fluid or other contaminants typically associated with these types of actuation methods.

Belt, cable, and chain-drive mechanisms are relatively inexpensive. However, they aren't as precise, repeatable, or as safe to use as ball screws and lead screws. Their failure mode is either excessive wear or stretching, resulting in positioning inaccuracies during operation. These types of systems also have low load capacities.

Rack and pinion gear systems can be made to close tolerances, but lose precision as they wear and don't function as smoothly as ball screws, even when new. Because the force is supported by a few pinion teeth at any given time, the system also is limited in terms of load capacity.

Offset cam rollers rely on the tractive force between the rollers and the shaft to create linear motion, and therefore can handle only moderate loads. The higher the load, the more likely it is that the system will slip, reducing repeatability.

In summary, when compared to other types of mechanical actuation methods, Thomson ball screws and lead screws provide the most cost-effective combination of speed, accuracy, efficiency, repeatability, quiet operation, lubrication retention, load capacity, and compactness.

Thomson precision ball screw and lead screw assemblies are the first choice in precise, reliable, cost-effective linear actuation.

Thomson lead screws excel in applications which require the "just right" solution. They are easily customized to provide compact, quiet and accurate positioning in light to medium load applications. Materials are inert as a standard and allow use in applications ranging from clean room to marine. Best of all, the value is high as you don't pay for processes and features not required in your application.

Let Danaher Motion engineer your positioning screw today.

## Ball and Lead Screw vs. Other Actuation Methods

	Thomson Lead Screws	Thomson Ball Screws	Fluid Power	Belt, Cable, and Chain-Drive Mechanisms	Rack & Pinion	Offset Cam Rollers	Pneumatic Cylinders
Inexpensive	●	●	○	●		●	○
Low Power Consumption		●		●	●	●	
Low Maintenance	●	●		○	○	○	●
High Accuracy		●					
High Repeatability	○	●					
High Efficiency		●			○	○	
High Load Capacity		●	●				○
Compact Size	●	●			●		○
Speed	●	●		●	●		●
Low Noise	●	○		○		○	
Design Flexibility	●	●			○		
Contamination Tolerance	●	○	●				

● = always  
○ = in most cases



## Design Considerations for Choosing Screw Type

	THOMSON LEAD SCREW	THOMSON BALL SCREW
Load	Typically light (<100 lbs)	Usually heavy (>100lbs)
Cost	Low cost \$\$	Higher cost \$\$\$
Anti-backlash	Available – but has low stiffness	Available
Self-locking	Yes – but depends on lead and lubrication	Fail safe brake locking option
Efficiency	Generally ranges from 30% to 70%	Generally ranges from 85% to 95%
Duty Cycle	Limited to plastic heat transfer properties	Unlimited
Corrosion Resistance	Available in stainless steel as a standard	Wide range of available sizes in stainless steel, as well as coating and plating options
Lubrication	Can operate with or without lubrication depending on application	Must have lubrication Wide range of lubricants
Operating Temperature	Limited to expansion differences between the screw and the nut	Wide temperature range
Travel Speed	Available in wide range of leads	Typically mid-range leads
Vibration and Noise	Typically quiet, high leads are best	Ball re-circulation
Custom Availability	Great flexibility in customizing materials and geometry	Great flexibility in customizing materials and geometry - limited by ball path envelope
Catalog Page	13	43

## Lead Screw Applications

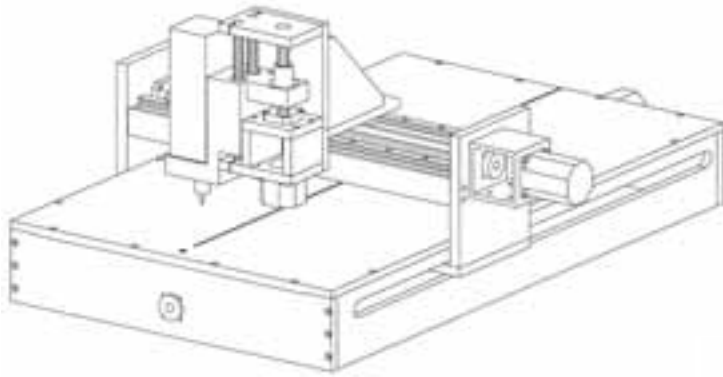

**ENGRAVING EQUIPMENT**

**MEDICAL EQUIPMENT**

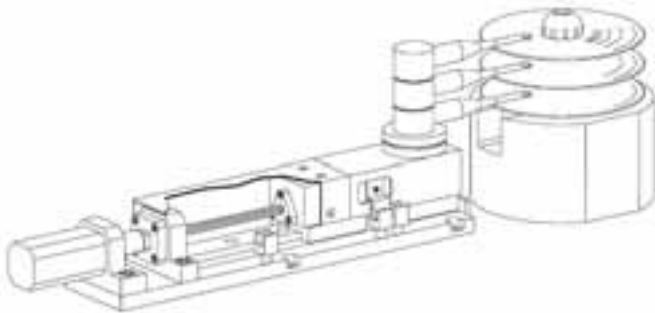
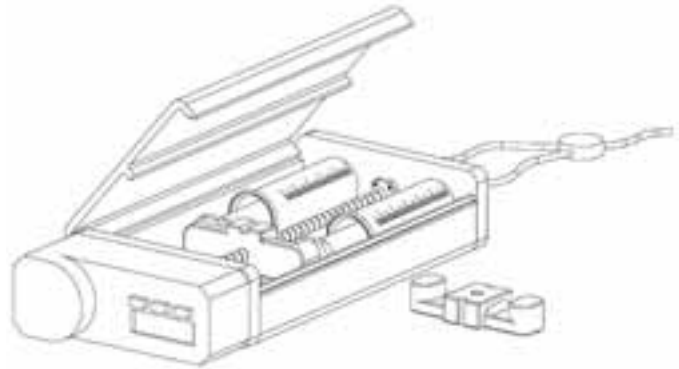

**SEMICONDUCTOR  
MANUFACTURING EQUIPMENT**

**LABORATORY EQUIPMENT**

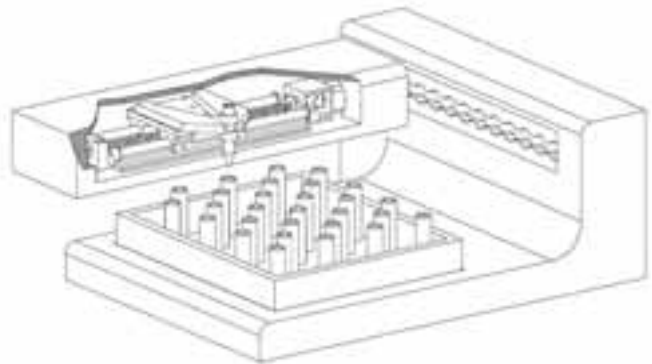

## Ball Screw Applications

### X-Y Inspection System

#### Products Specified

##### X-axis

- (A) 2 – S TWN-10-ADJ (Super Plus twin pillow blocks)
- (B) 4 – ASB M16 (aluminum support blocks)
- (C) 2 – 5/8" L 24" (60 Case\* LinearRace\* shafts)
- (D) 1 – .631 x .200 Thomson Precision Plus ball screw assemblies

##### Y-axis

- (E) 1 – 2CA 08 (pre-assembled linear motion system with a Thomson Precision Plus .631 x .200 ball screw assembly)
- 1 – .500 x .200 Thomson Precision ball screw assembly

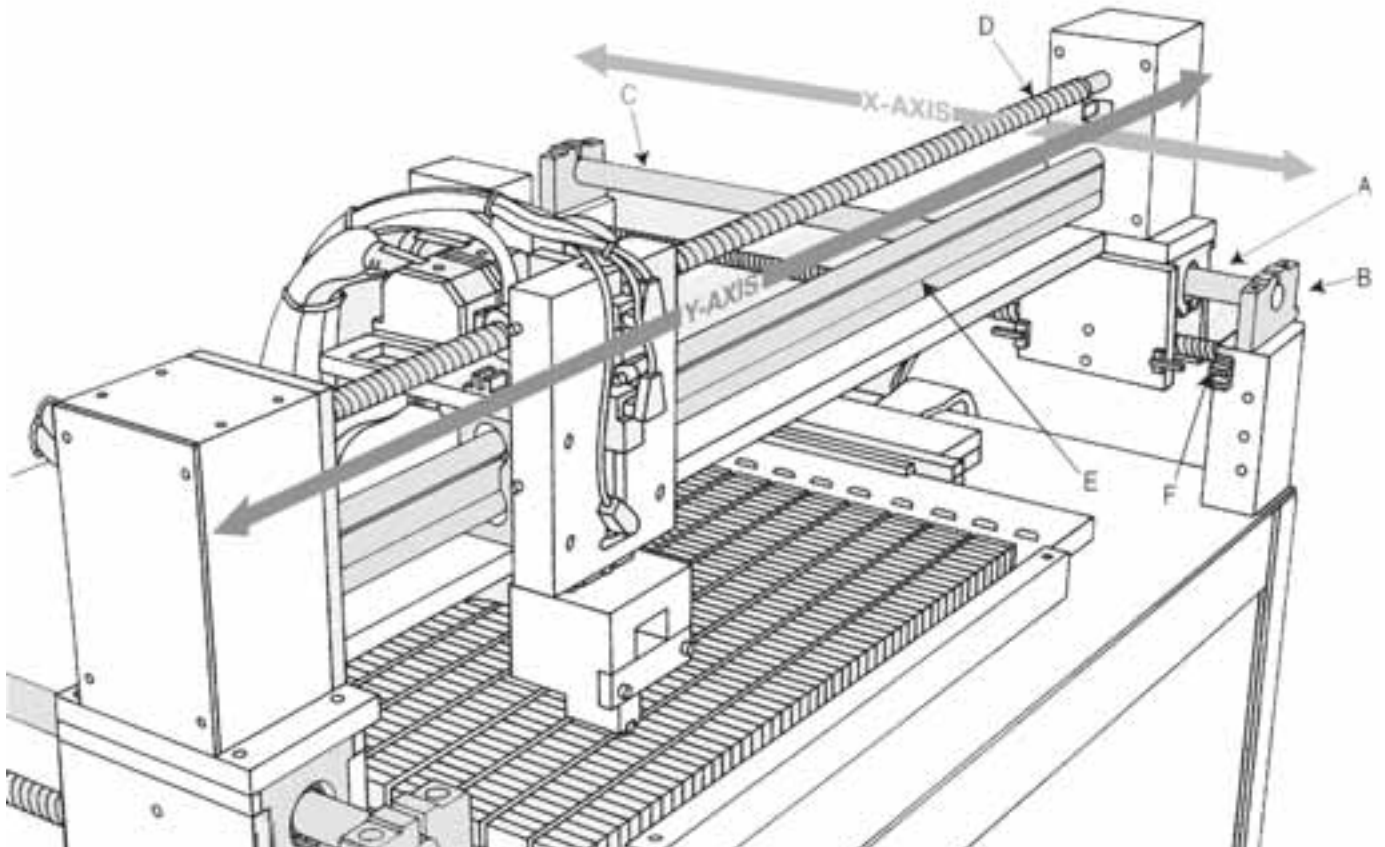

### Danaher Motion Advantage

In addition to our extensive standard ball and lead screw products, Danaher Motion has designed and manufactured custom engineered products to fit the unique requirements of our customers. We welcome and encourage requests for specialized products, regardless of quantity or frequency of order. Our custom products range from one-time-only units to high quantity requirements. A few of our custom possibilities are listed below:

### Custom Plastic Nuts

If cost or design constraints dictate a more integrated package, let our engineering staff help you simplify your design. We offer a full range of manufacturing capabilities from injection molding to CNC machining with the largest selection of engineering plastics to suit your applications and specifications.

- Our engineering staff will ensure your part is right the first time
- Full range of engineering plastics including internally lubricated and high temperature thermoplastics

### Precision Screw Products

Danaher Motion provides engineering support and quality assurance for all of its components and assemblies allowing our customers to focus on the larger design picture. Our full range of designs and sizes for our linear motion components allow greater design flexibility, while our support staff ensures proper initial application and comprehensive support once installed.

### Components and Assemblies

From components to complete assemblies, Danaher Motion always provides the highest performance products to your applications. Let us assist in your design to ensure proper operation of our components, or let us provide you a complete solution.

- Complete solutions to your linear motion designs with our industry tested assemblies
- Full complement of linear motion components: Rails (square and round), Motor Mounts, Bearing Mounts, Ball Nuts, Acme Plastic Nuts, Bronze Nuts, Anti-Backlash Nuts, Miniature Ball Nuts, Bearings, and more

If you don't see it, just ask us. Our application engineers will help you specify these options and modifications or they will work with you to create entirely new ones which will improve your machine's performance and lower your cost.

### Design Ranges

During our 65 plus years of servicing customers, our engineers have continuously developed new lead screw, ball screw, and spline assemblies required for many of industry's most unique, demanding applications. Our current product offering represents our evolving and expanding design and manufacturing capabilities.

The result of this experience is a portfolio of capabilities second to none. Danaher Motion is the pioneer in the design and manufacture of:

- High speed ball screws – up to 300 in/min
- Telescoping assemblies – up to five sections
- Hollow shafting for low inertia and low weight
- Safety nuts with up to five redundant load paths
- Nylon nuts, offering extreme speeds and loads
- Ultimate accuracy assemblies – up to .0002 in/ft

### Rotating Nut Ball Screw for High Speed Applications

- Linear speeds up to 100m/min.
- Unique design eliminates critical speeds that limit traverse rates
- Increase speed, reduce vibration and noise with Hollow Screw option
- 2 times the transfer rate of standard units
- Increased rigidity with new end support units
- Contact factory for your application



## Lead Screws and Supernuts®, and Miniature Ball Screws



## Lead Screw Product Summary

Series	Thomson Precision Lead Screw	
	Inch	Metric
Lead accuracy	.010"/ft. for standard .003"/ft. for precision	
Dia. x Lead	3/16" x .05" to 3" x 1/4"	10 x 2mm to 24 x 5mm
Backlash	zero to .010"	zero to .25mm
Dynamic Load	Up to 400 lbs	Up to 750N
Max. Static Load	Up to 115,000 lbs	Up to 500 kN
Catalog Pages	20 - 38	20 - 38

## Lead Screw Product Availability

### Inch

### Lead (in)

	0.050	0.063	0.083	0.100	0.125	0.167	0.200	0.250	0.375	0.500	0.800	1.000	1.200	2.000
3/16	●													
1/4	●	●						●		●				
5/16			●			●		●		●				
3/8		●	●	●	●	●	●	●	●	●		●	●	
7/16					●			●		●				
1/2		●		●			●	●		●	●	●		
5/8				●	●		●	●		●				
3/4				●	●	●	●			●		●		●
1				●	●		●	●		●		●		
1 1/4							●	●						
1 1/2							●	●	●	●				
2								●						
2 1/4								●						
2 1/2								●						
2 3/4								●						
3								●						

### Metric

### Lead (mm)

	2	3	4	5	6	8	10	12	15	16	20	25	35	45
10	●	●		●	●		●				●		●	
12		●	●	●	●		●		●			●		●
16			●	●		●				●		●	●	
20			●			●		●		●	●			●
24				●										

- = stocked size
- = available Q2 2004

## Offering smooth, precise, cost effective positioning, this is the “just right” solution for your application.

Thomson precision lead screws are an excellent economical solution for your linear motion requirements. For more than 25 years, Danaher Motion has designed and manufactured the highest quality lead screw assemblies in the industry. Our precision rolling machines ensure accurate positioning to 0.003 in/ft and our PTFE coating process produces assemblies that have less drag torque and last longer.

Danaher Motion provides a large array of standard plastic nut assemblies in anti-backlash or standard Supernut® designs. All of our standard plastic nut assemblies use an internally lubricated Acetal - providing excellent lubricity and wear resistance with or without additional lubrication. With the introduction of our new unique patent pending zero backlash designs, Danaher Motion provides assemblies with high axial stiffness, zero backlash and the absolute minimum drag torque to reduce motor requirements. These designs produce products that cost less, perform better and last longer. Both designs automatically adjust for wear insuring zero backlash for the life of the nut.

For significantly higher loads, standard bronze nuts are available. Danaher Motion uses SAE 660 bearing bronze, which provides high load capacity with good PV performance. We also offer end machining to your specification or can provide you with stock bearing mounts or motor mounts. Available from over 1800 distributors worldwide.

Danaher Motion also provides engineering design services to aid in your design requirements producing a lead screw assembly to your specifications. Call the factory today to discuss your application with one of our experienced application engineers, 1-800-554-8466.

## Critical Speed Limits Chart For Lead Screws and Miniature Ball Screws

Every screw shaft has a rotational speed limit. That is the point at which the rotational speed sets up excessive vibration. This critical point is modified by the type of end bearing support used.

To use this chart, determine the required RPM and the maximum length between bearing supports. Next, select one of the four types of end support shown below. The critical speed limit can be found by locating the point at which RPM's (horizontal lines) intersects with the unsupported screw length (vertical lines) as modified by the type of supports select below. We recommend operating at no more than 80% of the critical speed limit to allow for misalignment and/or lack of screw straightness.

**Warning:** Curves for the screw diameters shown are based on the smallest root (minor) diameter of the standard screws within the nominal size range and truncated at the maximum ball nut rotational speed. DO NOT EXCEED this RPM regardless of screw length.

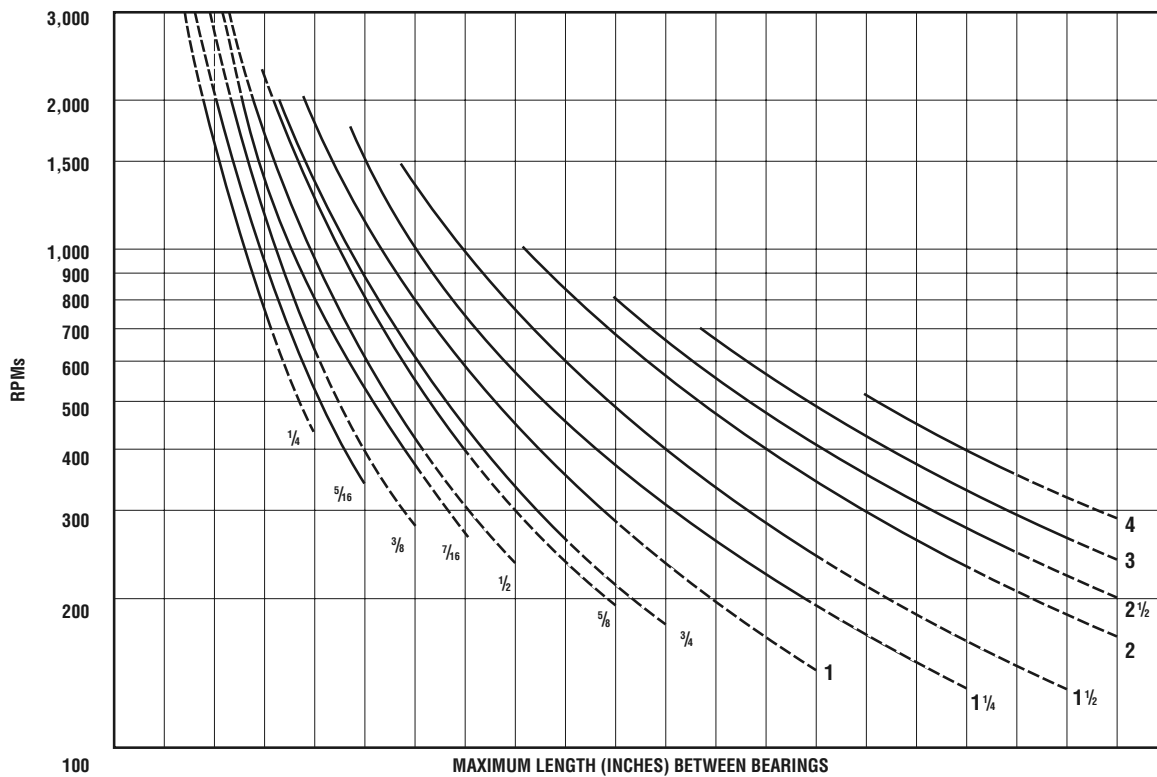

(A) Fixed-Free	6	12	18	24	30	36	42	48	54	60	66	72	78	84	90	96	102	108	120	126
(B) Simple-Simple	10	20	30	40	50	60	70	80	90	100	110	120	130	140	150	160	170	180	190	200
(C) Fixed-Simple	12	24	36	48	61	73	85	97	109	121	133	154	158	170	182	194	206	218	230	242
(D) Fixed-Fixed	15	30	45	60	75	90	105	119	134	149	164	179	194	209	224	239	254	269	284	298

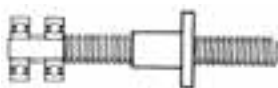

(A) Fixed-Free



(B) Simple-Simple

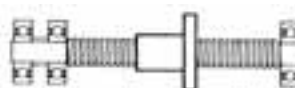

(C) Fixed-Simple

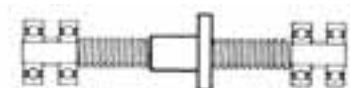

(D) Fixed-Fixed



## Column Loading Capacities Chart

Use the chart below to determine the Maximum Compression Load for Screw Shaft. Usually, screw operated in tension can handle loads up to the rated capacity of the nut, providing the screw length is within standard lengths. End supports have an effect on the load capacity of screws. The four standard variations are shown below with corresponding rating adjustments. Find the point of intersecting lines of load (horizontal) and length (vertical) to determine the minimum safe diameter of screw. If loads fall into dotted lines, consult factory.

**Warning: DO NOT EXCEED ball nut capacity.** Curves for the screw diameters shown are based on the smallest root (minor) diameter of the standard screws within the nominal size range.

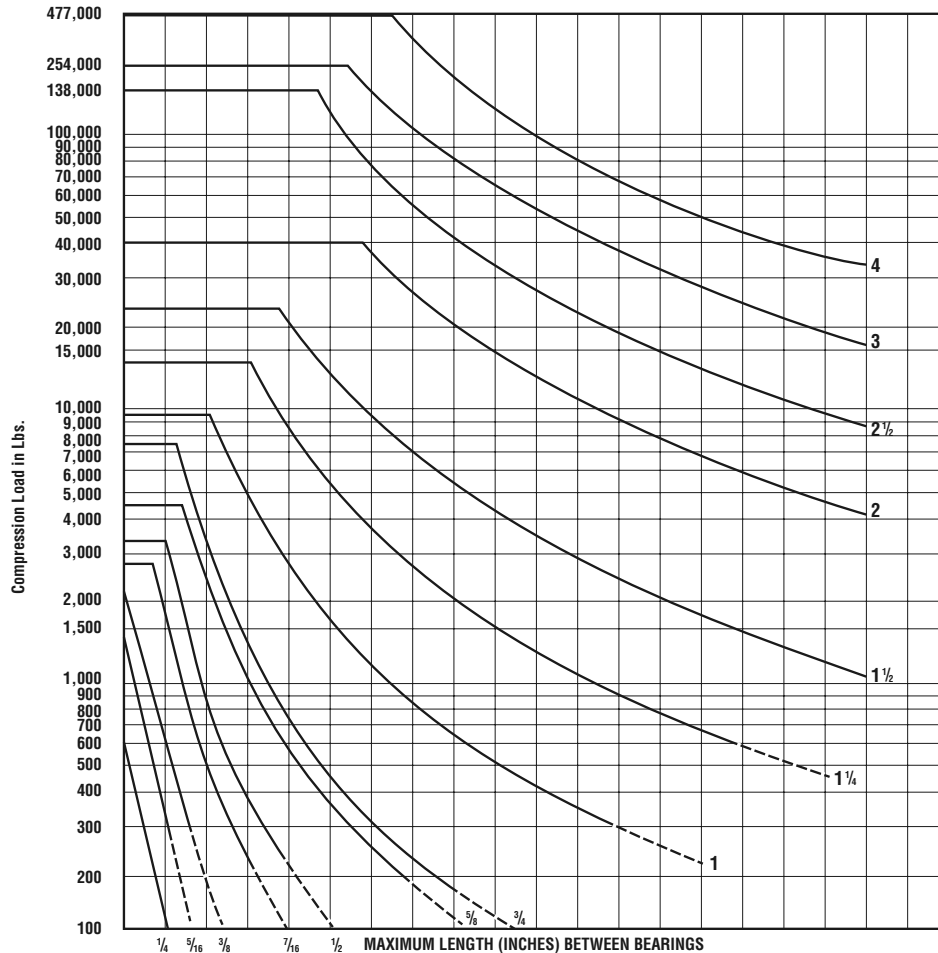

(A) Fixed-Free	5	10	15	20	25	30	35	40	45	50	55	60	65	70	75	80	85	90	95
(B) Simple-Simple	10	20	30	40	50	60	70	80	90	100	110	120	130	140	150	160	170	180	190
(C) Fixed-Simple	14	28	42	57	71	85	99	113	127	141	156	170	184	198	212	226	240	255	270
(D) Fixed-Fixed	20	40	60	80	100	120	140	160	180	200	220	240	260	280	300	320	340	360	380

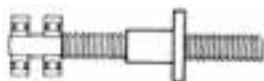

(A) Fixed-Free

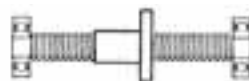

(B) Simple-Simple



(C) Fixed-Simple



(D) Fixed-Fixed



Compression (Column) Load



Tension (Pulling) Load

## Precision Lead Screws & Supernuts®, and Miniature Ball Screws

### Features/Advantages

#### Low Cost

Considerable savings when compared to ball screw assemblies.

#### Variety

Largest range of leads and diameters 3/16" to 3" to match your requirements.

#### Lubrication

Internally lubricated plastic nuts will operate without lubrication or PTFE coating of the screw is recommended.

#### Vibration and Noise

No ball recirculating vibration and often less audible noise compared to ball screws.

### Design Considerations

#### Load

Supernuts provide a cost effective solution for moderate to light loads. For vertical applications, anti backlash supernuts should be mounted with thread/flange on the bottom.

#### Cantilevered Loads

Cantilevered loads that might cause a moment on the nut will cause premature failure.

#### Column Loading

Refer to column loading chart on page 17.

#### Critical Speed

Refer to critical speed chart on page 16.

#### Self-Locking

Lead screws can be self locking at low leads. Generally, the lead of the screw should be more than 1/3 of the diameter to satisfactorily backdrive.

#### Custom

Option of custom designs to fit into your design envelope.

#### Non-Corrosive\*

Stainless Steel and internally lubricated acetal.

#### Environment

Less susceptible to particulate contamination compared to ball screws.

#### Lightweight

Less mass to move.

#### Temperature

Ambient and friction generated heat are the primary causes of premature plastic nut failure. Observe the temperature limits below and discuss your design with our application engineers for continuous duty, high load and high speed applications. Danaher Motion recommends bronze nuts for very high temperature environments or can aid in your selection of high temperature plastic for a custom assembly.

#### Efficiency

Except at very high leads, efficiency increases as lead increases. Although the internally lubricated acetal provides excellent lubricity, Ball Screw Assemblies remain significantly more efficient than any Acme design.

#### Length Limitations

3/16" to 1/4"	3'
5/16 to 10mm	4'
7/16" to 5/8"	6'
>5/8"	12'

#### Lead Accuracy

Standard Grade (SRA)	.010 in/ft
Precision Grade (SPR)	.003 in/ft

Assembly		Screws	Nuts**			
Maximum Temperature	Friction Coefficient	Material	Material	Tensile Strength	Water Absorption (24 HRS %)	Thermal Expansion Coefficient
180°F	0.08 - 0.14	Stainless Steel*	Acetal with PTFE	8,000 psi	0.15	5.4 x 10 <sup>-5</sup> in/in/°F

\* Other materials available on a custom basis.

\*\* Plastic nuts only. See bronze nut section for information on our bronze nut products, page 34.

NOTES:

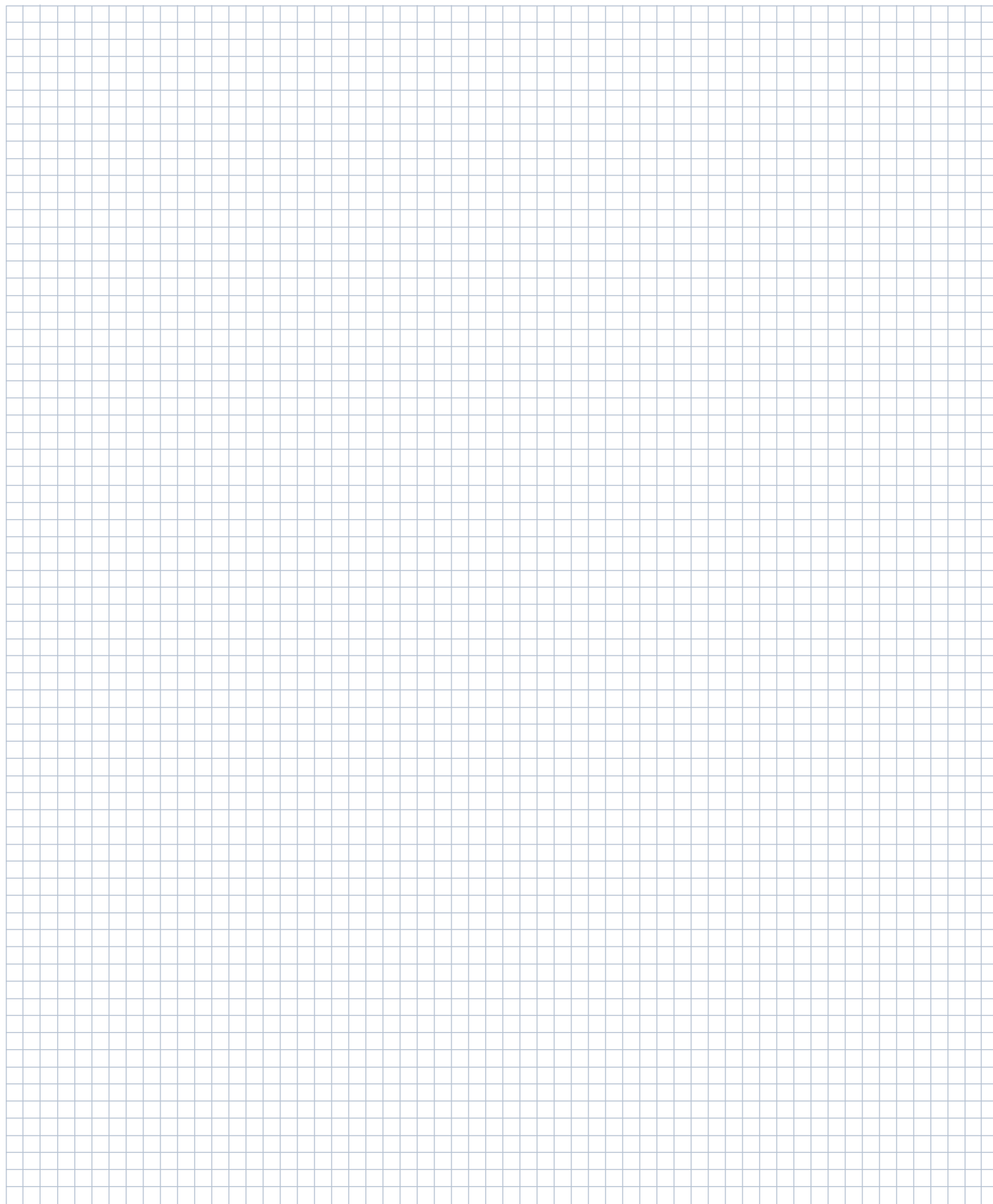

Advanced Anti-Backlash Supernuts®

XCM 1800

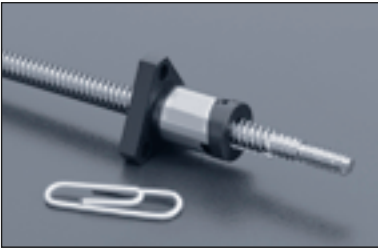

Our smallest anti-backlash nut design ever. The XCM 1800 uses the same patented ActiveCAM™ mechanism as its larger siblings in a miniaturized package. This allows backlash free operation in space critical applications requiring high accuracy and low drag torque. This cost effective solution is available in either flanged or threaded versions.

Note: See Screw Section on page 36. Specify XCMT or XCMF when ordering, see drawings at right.

XCMT 1800

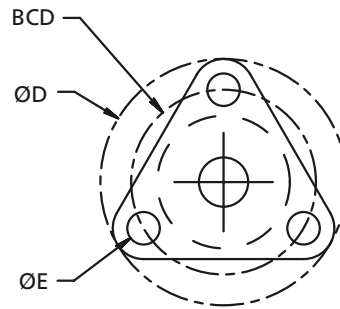
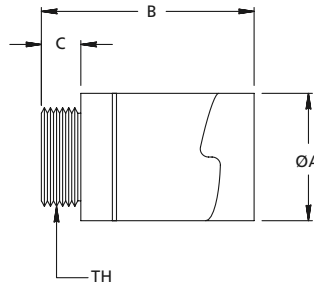

XCMF 1800

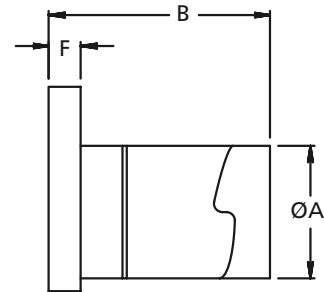

DIA.	LEAD	PART NO.	SUPERNUT® DIMENSIONS								DESIGN LOAD	EFFICIENCY %	DRAG TORQUE OZ-IN
			A	B	C	D	E	F	BCD	TH			
3/16"	0.050	XCM_1820	0.50	.90 max	0.200	1.00	0.143	0.18	0.750	7/16-20	5 lbs	49	< 1
6 mm*	1 mm	XCM_6x1										29	
1/4" *	0.0125	XCM_2580										13	
	0.0208	XCM_2548										20	
	0.0250	XCM_2540										23	
	0.0278	XCM_2536										25	
	0.0313	XCM_2532										28	
	0.0357	XCM_2528										30	
1/4"	0.0417	XCM_2524										34	
	0.050	XCM_2520										41	
	0.063	XCM_2516										48	
	0.250	XCM_4-2516										76	
	0.500	XCM_7-2514										81	

\* Vee-thread screws, see page 38.

† Patent No. 5839321

## Advanced Anti-Backlash Supernuts®

### XC 2500

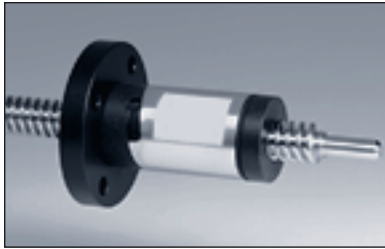

The XC Model Anti-Backlash assembly is the most advanced Anti-Backlash nut design. The unique Patented† ActiveCAM™ accomplishes high axial stiffness, zero backlash and the absolute minimum drag torque. This advantage produces assemblies that cost less, perform better and last longer. The ActiveCAM™ automatically adjusts for wear insuring zero backlash for the life of the nut.

Note: See Screw Section on page 36. Specify XCT or XCF when ordering, see drawings at right.

**XCT 2500**

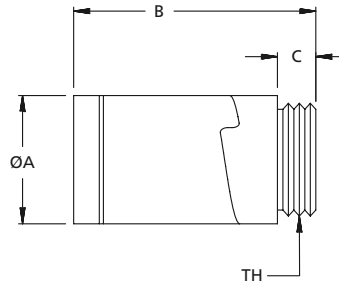

**XCF 2500**

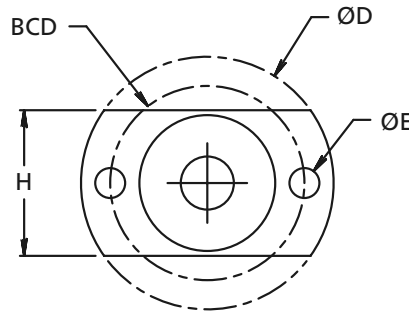
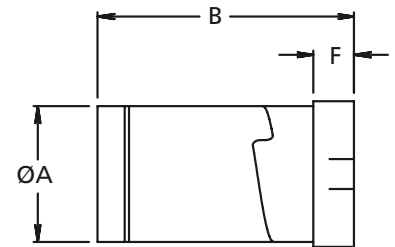

DIA.	LEAD	PART NO.	SUPERNUT® DIMENSIONS									DESIGN LOAD	EFFICIENCY %	DRAG TORQUE OZ-IN
			A	B	C	D	E	F	H	BCD	TH			
3/16"	0.050	XC_1820	0.64	1.18 max	0.187	1.19	0.141	0.16	0.66	0.900	9/16-18	10 lbs	49	< 1
6 mm*	1 mm	XC_6x1											29	
1/4" *	0.0125	XC_2580											13	
	0.0208	XC_2548											20	
	0.0250	XC_2540											23	
	0.0278	XC_2536											25	
	0.0313	XC_2532											28	
	0.0357	XC_2528											30	
1/4"	0.0417	XC_2524											34	
	0.050	XC_2520											41	
	0.063	XC_2516											48	
	0.250	XC_4-2516											76	
	0.500	XC_7-2514											81	

\* Vee-thread screws, see page 38.

† Patent No. 5839321

## Advanced Anti-Backlash Supernuts®

### XC 3700

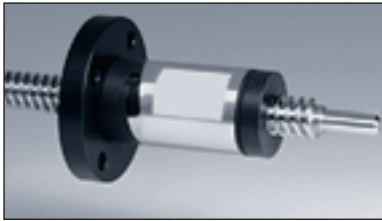

The XC Model Anti-Backlash assembly is the most advanced Anti-Backlash nut design. The unique Patented ActiveCAM™ accomplishes high axial stiffness, zero backlash and the absolute minimum drag torque. This advantage produces assemblies that cost less, perform better and last longer. The ActiveCAM™ automatically adjusts for wear insuring zero backlash for the life of the nut.

Note: See Screw Section on page 36. Specify XCT or XCF when ordering, see drawings at right.

### XCT 3700

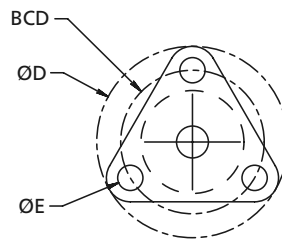
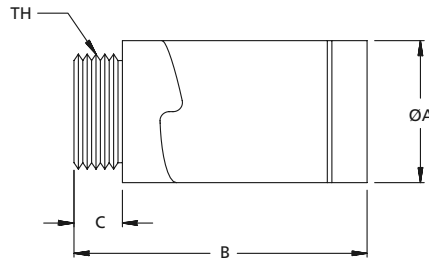

### XCF 3700

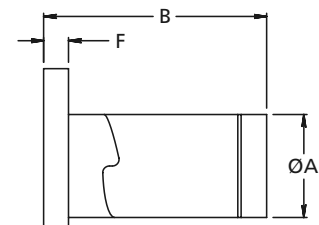

DIA.	LEAD	PART NO.	SUPERNUT® DIMENSIONS								DESIGN LOAD	EFFICIENCY %	DRAG TORQUE OZ-IN
			A	B	C	D	E	F	BCD	TH			
5/16"	0.083	XC_3112	0.82	1.875 (max)	0.25	1.5	0.2	0.2	1.125	5/8"-18	25 lbs	49	1 - 3
	0.167	XC_2-3112										65	
	0.250	XC_2-3108										72	
	0.500	XC_4-3108										80	
3/8"	0.063	XC_3716										36	
	2mm	XC_37x2M										42	
	0.083	XC_3712										44	
	0.100	XC_3710										49	
	0.125	XC_3708										53	
	0.167	XC_2-3712										60	
	0.200	XC_2-3710										65	
	0.250	XC_2-3708										68	
	0.375	XC_4-3711										75	
	0.500	XC_4-3708										79	
10mm	2mm	XC_10x2M										41	
	3mm	XC_10x3M										53	
	6mm	XC_4-10x1.5M	67										
	20mm	XC_6-10x3.3M	81										

† Patent No. 5839321

**Advanced Anti-Backlash Supernuts®**

**XC 5000**

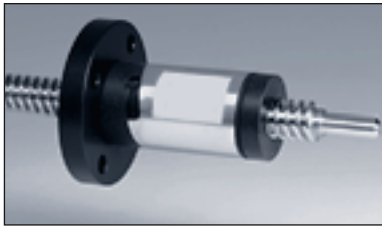

The XC 5000 utilizes the same Patented† ActiveCAM™ as found in the XC3700 model. Along with the very low drag torque and high axial stiffness advantages, the XC 5000 has greater load capacity.

Note: See Screw Section on page 36. Specify XCT or XCF when ordering, see drawings at right.

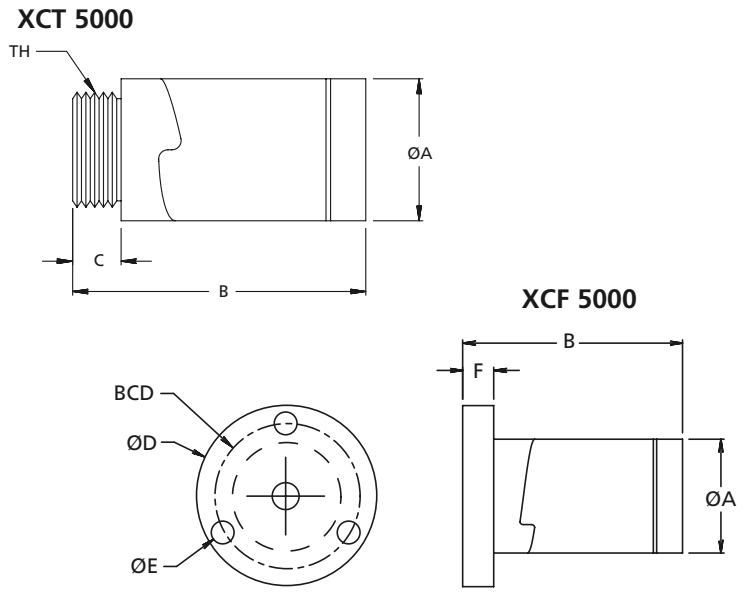

DIA.	LEAD	PART NO.	SUPERNUT® DIMENSIONS								DESIGN LOAD	EFFICIENCY %	DRAG TORQUE OZ-IN
			A	B	C	D	E	F	TH	BCD			
7/16"	0.125	XC_2-4316	1.12	2.25 (max)	0.375	1.75	0.2	0.3	15/16-16	1.406	125 lbs	55	1 - 3
	0.250	XC_2-4308										65	
	0.500	XC_4-4308										76	
12mm	5mm	XC_2-12x2.5M										59	
	10mm	XC_4-12x2.5M										73	
1/2"	.0625	XC_5016										30	
	0.100	XC_5010										41	
	0.200	XC_2-5010										57	
	0.250	XC_2-5008										62	
	0.500	XC_4-5008										75	
	0.800	XC_8-5010	80										
	1.000	XC_8-5008	81										

† Patent No. 5839321

## Advanced Anti-Backlash Supernuts®

### XC 6200

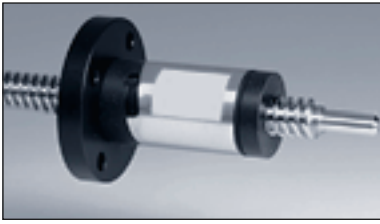

The XC 6200 utilizes the same Patented† ActiveCAM™ as found in the XC 5000 model. Along with the very low drag torque and high axial stiffness advantages, the XC 6200 has greater load capacity.

Note: See Screw Section on page 36. Specify XCT or XCF when ordering, see drawings at right.

**XCT 6200**

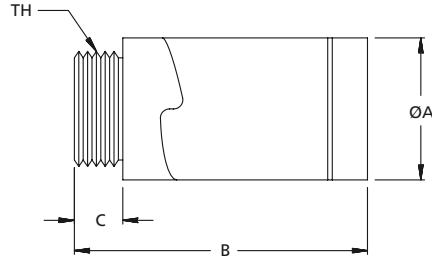

**XCF 6200**

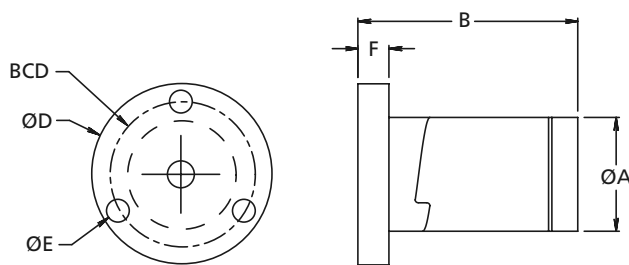

DIA.	LEAD	PART NO.	SUPERNUT® DIMENSIONS									EFFICIENCY %	DRAG TORQUE OZ-IN
			A	B	C	D	E	F	BCD	TH	DESIGN LOAD		
5/8"	0.100	XC_6210	1.40	2.60 (max)	0.5	2.13	0.22	0.5	1.688	1.25-16	175 lbs	35	2-6
	0.125	XC_6208										40	
	4mm	XC_62x4M										46	
	0.200	XC_2-6210										51	
	0.250	XC_2-6208										57	
	0.500	XC_4-6208										71	
16mm	4mm	XC_16x4M										47	

† Patent No. 5839321



**Advanced Anti-Backlash Supernuts®**

**XC 7500**

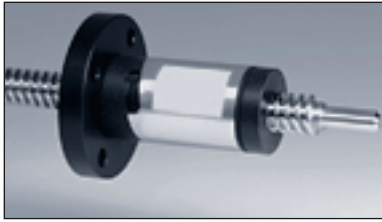

The XC 7500 utilizes the same Patented ActiveCAM™ as found in the XC 5000 model. Along with the very low drag torque and high axial stiffness advantages, the XC 7500 has greater load capacity.

Note: See Screw Section on page 36. Specify XCT or XCF when ordering, see drawings at right.

**XCT 7500**

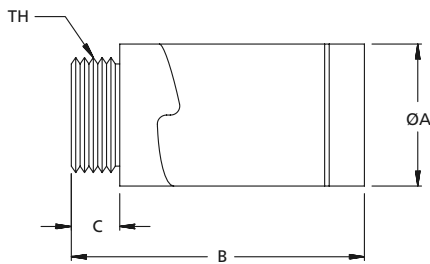

**Flange 7500**

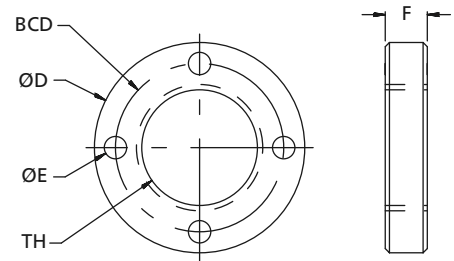

DIA.	LEAD	PART NO.	NUT DIMENSIONS			TH	FLANGE DIMENSIONS (OPTIONAL)				DESIGN LOAD	EFFICIENCY %	DRAG TORQUE OZ-IN
			A	B	C		D	E	F	BCD			
3/4"	0.100	XCT7510	1.63	2.9 (max)	0.5	1 3/8 - 16	2.5	0.27	0.50	2.00	250 lbs	31	3 - 10
	0.125	XCT7508										36	
	0.167	XCT7506										44	
	0.200	XCT7505										49	
	0.500	XCT5-7510										69	
	1.000	XCT8-7508										79	
	2.000	XCT10-7505										82	
20mm	4mm	XCT20x4M									41		

† Patent No. 5839321

## Advanced Anti-Backlash Supernuts®

### XC 10000

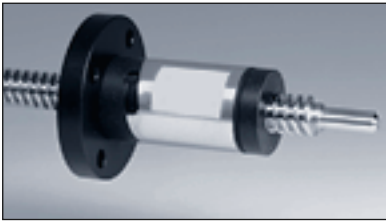

The XC 10000 utilizes Thomson Patented' ActiveCAM™ technology to provide very low drag torque, high axial stiffness and maximum wear life. This self compensating design produces excellent positional repeatability while insuring consistent performance for the long run.

Note: See Screw Section on page 36. Specify XCT or XCF when ordering, see drawings at right.

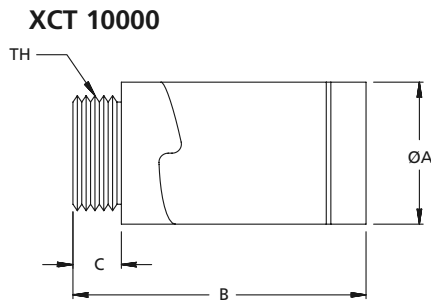

### FLANGE F100

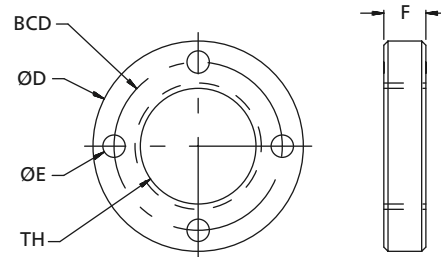

DIA.	LEAD	PART NO.	NUT DIMENSIONS			TH	FLANGE DIMENSIONS (OPTIONAL)				DESIGN LOAD	EFFICIENCY %	DRAG TORQUE OZ-IN
			A	B	C		D	E	F	BCD			
24mm	5mm	XCT24x5M	1.88	3.0 (max)	0.60	1 9/16-18	3.0	0.27	0.60	2.37	350 lbs	42	5 - 15
1"	0.100	XCT1010										25	
	0.125	XCT1008										29	
	0.200	XCT1005										41	
	0.250	XCT1004										47	
	0.500	XCT5-1010										61	
	1.000	XCT10-1010										74	

† Patent No. 5839321

## Advanced Anti-Backlash Supernuts®

AFT



The low cost AFT Supernut is designed for light load OEM applications and offers smooth movement and low drag torque for axial loads up to 10 pounds. The AFT anti-backlash collar automatically adjusts for wear for the life of the nut.

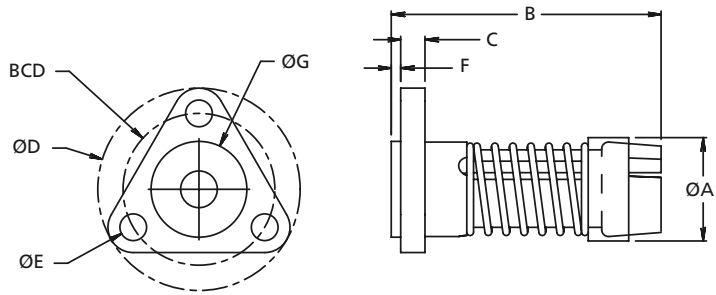

DIA.	LEAD	PART NO.	SUPERNUT® DIMENSIONS								DESIGN LOAD	EFFICIENCY %	DRAG TORQUE OZ-IN
			A	B	C	D	E	F	G	BCD			
3/8"	0.063	AFT3716	0.77	2.00	0.20	1.50	0.20	0.06	0.71	1.125	10 lbs	36	2 - 5
	2mm	AFT37x2M										42	
	0.083	AFT3712										44	
	0.100	AFT3710										49	
	0.125	AFT3708										53	
	0.167	AFT2-3712										60	
	0.200	AFT2-3710										65	
	0.250	AFT2-3708										68	
	0.375	AFT4-3711										75	
	0.500	AFT4-3708										79	
	1.000	AFT5-3705										82	
1.200	AFT5-3704	82											
10mm	2mm	AFT10x2M										41	
	3mm	AFT10x3M										53	
	6mm	AFT4-10x1.5M										67	
	20mm	AFT6-10x3.3M										81	
7/16	0.125	AFT2-4316										55	
	0.250	AFT2-4308										65	
	0.500	AFT4-4308										76	

† Patent No. 5839321

## Anti-Backlash Supernuts®

### SNAB Thread Mount Style

Our SNAB Model has the greatest design flexibility allowing anti-backlash assemblies through 1" diameters. All SNABs are made from our internally lubricated Acetal providing excellent lubricity and very low wear.

#### FLANGES

3/16" to 1/4"	F25
5/16" to 10mm	F37

Dimensions available online.

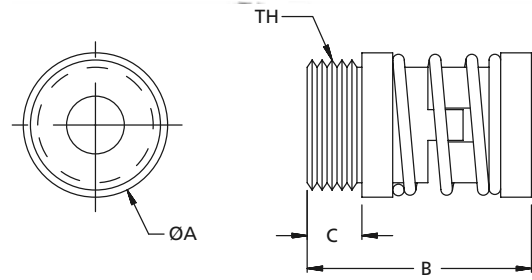

### SNAB\* 3/16" to 10mm Diameter

DIA.	LEAD	PART NO.	SUPERNUT® DIMENSIONS					PRELOAD FORCE (LBS)	DESIGN LOAD	MAX STATIC LOAD	EFFICIENCY %	DRAG TORQUE (oz-in)
			A	B (min)	B (max)	C	TH					
3/16"	0.050	SNAB1820X	0.625	1.125	1.250	0.187	9/16-18	1-3	10 lbs	150 lbs	49	2-4
1/4"	0.050	SNAB2520X	0.625	1.125	1.250	0.187	9/16-18	1-3	25 lbs	225 lbs	41	2-4
	0.063	SNAB2516X									48	
	0.250	SNAB4-2516X									76	
	0.500	SNAB7-2514X									81	
5/16"	0.083	SNAB3112X	0.750	1.160	1.340	0.250	5/8-18	2-5	50 lbs	350 lbs	49	2-4
	0.167	SNAB2-3112X									65	
	0.250	SNAB2-3108X									72	
	0.500	SNAB4-3108X									80	
3/8"	0.063	SNAB3716X	0.750	1.160	1.340	0.250	5/8-18	2-5	70 lbs	350 lbs	36	2-4
	2mm	SNAB37x2M									42	
	0.083	SNAB3712X									44	
	0.100	SNAB710X									49	
	0.125	SNAB3708X									53	
	0.167	SNAB2-3712X									60	
	0.200	SNAB2-3710X									65	
	0.250	SNAB2-3708X									68	
	0.375	SNAB4-3711X									75	
	0.500	SNAB4-3708X									79	
	1.000	SNAB5-3705X									82	
1.200	SNAB5-3704X	82										
10mm	2mm	SNAB10x2M	0.750	1.160	1.340	0.250	5/8-18	2-5	70 lbs	350 lbs	41	2-4
	3mm	SNAB10x3M									53	
	6mm	SNAB4-10x1.5M									67	
	20mm	SNAB6-10x3.3M									81	

\* SNAB nuts are only as axially stiff as the spring force in one direction.

**Anti-Backlash Supernuts®**

**FLANGES**

7/16" to 16mm	F50
3/4" to 1"	F100

Dimensions available online.

**SNAB\*  
 7/16" to 1" Diameter**

DIA.	LEAD	PART NO.	SUPERNUT® DIMENSIONS					PRELOAD FORCE (LBS)	DESIGN LOAD	MAX STATIC LOAD	EFFICIENCY %	DRAG TORQUE (oz-in)
			A	B (min)	B (max)	C	TH					
7/16"	0.125	SNAB2-4316X	1.000	1.700	2.000	0.375	15/16-16	4-9	100 lbs	500 lbs	55	3-5
	0.250	SNAB2-4308X									65	
	0.500	SNAB4-4308X									76	
12mm	5mm	SNAB2-12x2.5M	1.000	1.700	2.000	0.375	15/16-16	4-9	100 lbs	500 lbs	59	3-5
	10mm	SNAB4-12x2.5M									73	
1/2"	0.0625	SNAB5016	1.000	1.700	2.000	0.375	15/16-16	4-9	150 lbs	750 lbs	30	5-8
	0.100	SNAB5010X									41	
	0.200	SNAB2-5010X									57	
	0.250	SNAB2-5008X									62	
	0.500	SNAB4-5008X									75	
	0.800	SNAB8-5010X									80	
	1.000	SNAB8-5008X									81	
5/8"	0.100	SNAB6210X	1.000	1.700	2.000	0.375	15/16-16	4-9	160 lbs	800 lbs	35	7-10
	0.125	SNAB6208X									40	
	4mm	SNAB2-62x4M									46	
	0.200	SNAB2-6210X									51	
	0.250	SNAB2-6208X									57	
	0.500	SNAB4-6208X									71	
16mm	4mm	SNAB16x4M	1.000	1.700	2.000	0.375	15/16-16	4-9	160 lbs	800 lbs	47	7-10
3/4"	0.100	SNAB7510X	1.750	2.500	3.000	0.600	1 9/16-18	10-20	300 lbs	1500 lbs	31	15-20
	0.125	SNAB7508X									36	
	0.167	SNAB7506X									44	
	0.200	SNAB7505X									49	
	0.500	SNAB5-7510X									69	
	1.000	SNAB8-7508X									79	
	2.000	SNAB10-7505X									82	
20mm	4mm	SNAB20x4M	1.750	2.500	3.000	0.600	1 9/16-18	10-20	300 lbs	1500 lbs	41	15-20
24mm	5mm	SNAB24x5M	1.750	2.500	3.000	0.600	1 9/16-18	10-20	300 lbs	1500 lbs	42	15-20
1"	0.100	SNAB1010X	1.750	2.500	3.000	0.600	1 9/16-18	10-20	400 lbs	2000 lbs	25	15-20
	0.125	SNAB1008X									29	
	0.200	SNAB1005X									41	
	0.250	SNAB1004X									47	
	0.500	SNAB5-1010X									61	
	1.000	SNAB10-1010X									74	

\* SNAB nuts are only as axially stiff as the spring force in one direction.

## Flange Mount Supernuts®

### MTS

#### Integral Flange Mount

The MTS models provide the excellent lubricity and dimensional stability of our proprietary Acetal with the convenience of an integral flange.

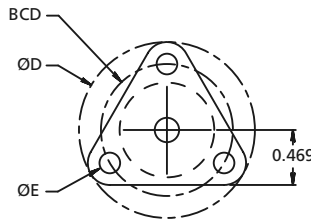

MTS 3/8" only

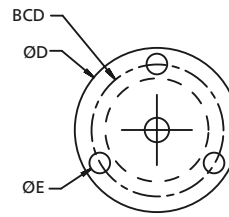

MTS 3/16" to 5/16"

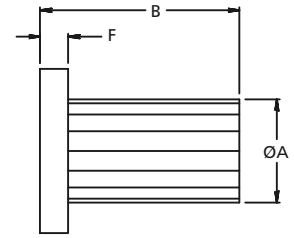

### MTS

#### 3/16" to 3/8" Diameter

DIA.	LEAD	PART NO.	SUPERNUT® DIMENSIONS						DESIGN LOAD	EFFICIENCY %	DRAG TORQUE (oz-in)
			A	B	D	E	F	BCD			
3/16"	0.050	MTS1820	0.50	0.75	1.00	0.14	0.15	0.75	10 lbs	49	Free Wheeling
1/4"	0.050	MTS2520	0.50	0.75	1.00	0.14	0.15	0.75	25 lbs	41	
	0.063	MTS2516								48	
	0.250	MTS4-2516								76	
	0.500	MTS7-2514								81	
5/16"	0.083	MTS3112	0.50	0.75	1.00	0.14	0.15	0.75	50 lbs	49	
	0.167	MTS2-3112								65	
	0.250	MTS2-3108								72	
	0.500	MTS4-3108								80	
3/8"	0.063	MTS3716	0.71	1.50	1.5	0.20	0.20	1.125	60 lbs	36	
	2mm	MTS37x2M								42	
	0.083	MTS3712								44	
	0.100	MTS3710								49	
	0.125	MTS3708								53	
	0.167	MTS2-3712								60	
	0.200	MTS2-3710								65	
	0.250	MTS2-3708								68	
	0.375	MTS4-3711								75	
	0.500	MTS4-3708								79	
	1.000	MTS4-3705								82	
	1.200	MTS5-3704								82	

\*3/8" to 7/16" with tri-flange

**Flange Mount Supernuts®**

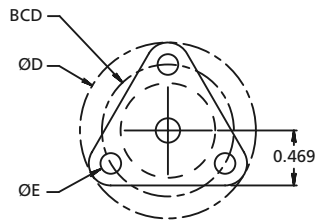

MTS 10mm to 7/16" only

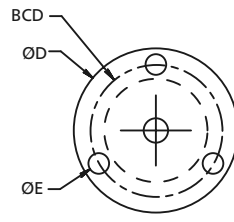

MTS 12mm to 3/4"

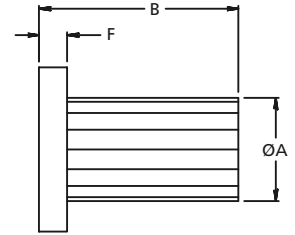

**MTS  
 10mm to 3/4" Diameter**

DIA.	LEAD	PART NO.	SUPERNUT® DIMENSIONS						DESIGN LOAD	EFFICIENCY %	DRAG TORQUE (oz-in)
			A	B	D	E	F	BCD			
10mm*	2mm	MTS10x2M	0.71	1.50	1.5	0.20	0.200	1.125	75 lbs	41	Free Wheeling
	3mm	MTS10x3M								53	
	6mm	MTS4-10x1.5M								67	
	20mm	MTS6-10x3.3M								81	
7/16"*	0.125	MTS2-4316	0.71	1.50	1.5	0.20	0.200	1.125	75 lbs	55	Free Wheeling
	0.250	MTS2-4308								65	
	0.500	MTS4-4308								76	
12mm	5mm	MTS2-12x2.5M	0.75	1.50	1.5	0.20	0.250	1.125	125 lbs	59	Free Wheeling
	10mm	MTS4-12x2.5M								73	
1/2"	0.0625	MTS5016	0.75	1.50	1.5	0.20	0.250	1.125	125 lbs	30	Free Wheeling
	0.100	MTS5010								41	
	0.200	MTS2-5010								57	
	0.250	MTS2-5008								62	
	0.500	MTS4-5008								75	
	0.800	MTS8-5010								80	
	1.000	MTS8-5008								81	
5/8"	0.100	MTS6210	0.88	1.63	1.5	0.20	0.300	1.188	175 lbs	35	Free Wheeling
	0.125	MTS6208								40	
	4mm	MTS62x4M								46	
	0.200	MTS2-6210								51	
	0.250	MTS2-6208								57	
	0.500	MTS4-6208								71	
16mm	4mm	MTS16x4M	0.88	1.63	1.5	0.20	0.300	1.188	175 lbs	47	Free Wheeling
3/4"	0.100	MTS7510	1.125	1.75	2.0	0.20	0.300	1.438	275 lbs	31	Free Wheeling
	0.125	MTS7508								36	
	0.167	MTS7506								44	
	0.200	MTS7505								49	
	0.500	MTS5-7510								69	
	1.000	MTS8-7508								79	
	2.000	MTS10-7505								82	

\*3/8" to 7/16" with tri-flange

## Thread Mount Supernuts®

### SN

Our standard SN nuts have proven themselves for the past twenty years. Available in sizes from 3/16" to 1-1/2" with or without mounting flanges.

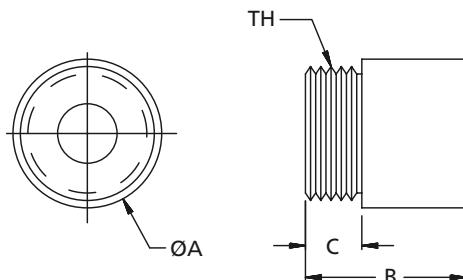

### FLANGES

3/16" to 1/4"	F25
5/16" to 10mm	F37
7/16" to 10mm	F50
3/4" to 1"	F75
1-1/4"	F100
1-1/2"	R54-3

Dimensions available online.

### MTS

### 3/16" to 7/16" Diameter\*

DIA.	LEAD	PART NO.	SUPERNUT® DIMENSIONS				DESIGN LOAD	MAX STATIC LOAD	EFFICIENCY %	DRAG TORQUE (oz-in)
			A	B	C	TH				
3/16"	0.050	SN1820X	0.625	0.500	0.187	9/16-18	30 lbs	150 lbs	49	F25
1/4"	0.050	SN2520X	0.625	0.500	0.187	9/16-18	45 lbs	225 lbs	41	
	0.063	SN2516X							48	
	0.250	SN4-2516X							76	
	0.500	SN7-2514X							81	
5/16"	0.083	SN3112X	0.750	0.750	0.250	5/8-18	70 lbs	350 lbs	49	F37
	0.167	SN2-3112X							65	
	0.250	SN2-3108X							72	
	0.500	SN4-3108X							80	
3/8"	0.063	SN3716X	0.750	0.750	0.250	5/8-18	70 lbs	350 lbs	36	
	2mm	SN37x2M							42	
	0.083	SN3712X							44	
	0.100	SN3710X							49	
	0.125	SN3708X							53	
	0.167	SN2-3712X							60	
	0.200	SN2-3710X							65	
	0.250	SN2-3708X							68	
	0.375	SN4-3711X							75	
	0.500	SN4-3708X							79	
	1.000	SN4-3705X							82	
	1.200	SN5-3704X							82	
10mm	2mm	SN10x2M	0.750	0.750	0.250	5/8-18	70 lbs	350 lbs	41	F50
	3mm	SN10x3M							53	
	6mm	SN4-10x1.5M							67	
	20mm	SN6-10x3.3M							81	
7/16"	0.125	SN2-4316X	1.000	1.000	0.375	15/16-16	100 lbs	500 lbs	55	
	0.250	SN2-4308X							65	
	0.500	SN4-4308X							76	

\*For all sizes shown on this page Drag Torque = Free Wheeling



**Thread Mount Supernuts®**

**SN  
 12mm to 1-1/2" Diameter\***

DIA.	LEAD	PART NO.	SUPERNUT® DIMENSIONS				DESIGN LOAD	MAX STATIC LOAD	EFFICIENCY %	FLANGE
			A	B	C	TH				
12mm	5mm	SN2-12x2.5M	1.000	1.000	0.375	15/16-16	100 lbs	500 lbs	59	F50
	10mm	SN4-12x2.5M							73	
1/2"	0.0625	SN5016X	1.000	1.000	0.375	15/16-16	150 lbs	750 lbs	30	
	0.100	SN5010X							41	
	0.200	SN2-5010X							57	
	0.250	SN2-5008X							62	
	0.500	SN4-5008X							75	
	0.800	SN8-5010X							80	
	1.000	SN8-5008X							81	
5/8"	0.100	SN6210X	1.000	1.000	0.375	15/16-16	160 lbs	800 lbs	35	
	0.125	SN6208X							40	
	4mm	SN62x4M							46	
	0.200	SN2-6210X							51	
	0.250	SN2-6208X							57	
	0.500	SN4-6208X							71	
16mm	4mm	SN16x4M	1.000	1.000	0.375	15/16-16	160 lbs	800 lbs	47	F75
3/4"	0.100	SN7510X	1.500	1.500	0.500	1 3/8-16	300 lbs	1500 lbs	31	
	0.125	SN7508X							36	
	0.167	SN7506X							44	
	0.200	SN7505X							49	
	0.500	SN5-7510X							69	
	1.000	SN8-7508X							79	
2.000	SN10-7505X	82								
20mm	4mm	SN20x4M	1.500	1.500	0.500	1 3/8-16	300 lbs	1500 lbs	41	
24mm	5mm	SN24x5M	1.500	1.500	0.500	1 3/8-16	300 lbs	1500 lbs	42	
1"	0.100	SN1010X	1.500	1.500	0.500	1 3/8-16	400 lbs	2000 lbs	25	
	0.125	SN1008X							29	
	0.200	SN1005X							41	
	0.250	SN5-1010X							47	
	0.500	SN5-1010X							61	
	1.000	SN10-1010X							74	
1 1/4"	0.200	SN1205X	2.000	2.000	0.600	1 9/16-18	400 lbs	2000 lbs	35	F100
	0.250	SN1204X							41	
1 1/2"	0.200	SN1505X	2.000	2.500	0.530	1.967-18	400 lbs	2000 lbs	31	R54-3
	0.250	SN1504X							36	
	0.375	SN1503X							47	
	0.500	SN2-1504X							52	

\*3/8" to 7/16" with tri-flange



## Bronze Nuts

For Acme Screws

Thread Mount Style

For standard bronze nuts, Danaher Motion uses SAE 660 bearing bronze which provides excellent load carrying ability, good wear resistance and is less susceptible to damage from impact and shock loading. Custom bronzes can be selected if required.

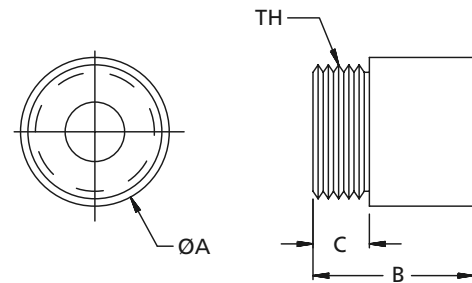

## Material Properties

MAXIMUM TEMPERATURE	FRICTION COEFFICIENT	MATERIAL*	TENSILE STRENGTH
max. 250° F	0.2 to 0.3	660SAE	35,000 psi

\* Other materials available on a custom basis.

## 1/4" to 5/8" Diameter

DIA.	LEAD	NUT PART NO. FOR R.H. SCREWS	NUT PART NO. FOR L.H. SCREWS	BRONZE NUT DIMENSIONS				FITS FLANGE NO.	DESIGN LOAD†	MAXIMUM STATIC LOAD	TORQUE TO RAISE 1 POUND (in-oz)
				A	B	C	TH				
1/4	.050	BN2520	BN2520L	.625	.625	.187	9/16-18	F25	110 lbs	550 lbs	.41
	.0625	BN2516	—								.43
	.250	BN4-2516	—								1.0
3/8	.0625	BN3716	—	.750	.750	.250	5/8-18	F37	300 lbs	1,500 lbs	.61
	.0833	BN3712	BN3712L								.64
	.100	BN3710	BN3710L								.67
	.125	BN3708S	—								.76
	.167	BN2-3712S	—								.86
1/2	.100	BN5010	BN5010L	1.00	1.00	.375	15/16-16	F50	620 lbs	3,100 lbs	.83
	.200	BN2-5010	—								1.10
5/8	.100	BN6210	BN6210L	1.00	1.00	.375	15/16-16	F50	860 lbs	4,300 lbs	.99
	.125	BN6208S	—								1.06
	.200	BN2-6210	—								1.26

† Load ratings based on using Thomson grease. See page 147.

\* 3/4" to 3" continued on next page

## Bronze Nuts

For Acme Screws  
 Thread Mount Style

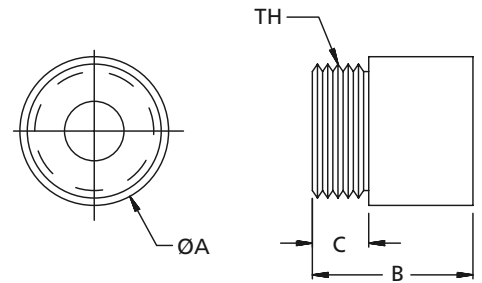

### 3/4" to 3" Diameter

DIA.	LEAD	NUT PART NO. FOR R.H. SCREWS	NUT PART NO. FOR L.H. SCREWS	BRONZE NUT DIMENSIONS				FITS FLANGE NO.	DESIGN LOAD†	MAXIMUM STATIC LOAD	TORQUE TO RAISE 1 POUND (in-oz)
				A	B	C	TH				
3/4	.100	BN7510	BN7510L	1.50	1.50	.500	1 3/8-16	F75	1,500 lbs	7,500 lbs	1.15
	.125	BN7508	—								1.21
	.167	BN7506	BN7506L								1.28
	.200	BN7505	BN7505L								1.35
1	.100	BN1010	—	1.50	1.50	.500	1 3/8-16	F75	1,900 lbs	9,500 lbs	1.47
	.125	BN1008	—								1.52
	.200	BN1005	—								1.67
	.250	BN1004	—								1.76
	.500	BN5-1010	—								2.55
	1.000	BN10-1010	—								3.91
1 1/4	.200	BN1205*	—	1.75	1.75	.625	1 9/16-18	R1004-3	3,000 lbs	15,000 lbs	1.99
	.250	BN1204*	—								2.09
1 1/2	.200	BN1505*	—	2.25	2.25	.530	1.967-18	R54-3	4,600 lbs	23,000 lbs	2.31
	.250	BN1504*	—								2.41
	.375	BN1503*	—								2.56
	.500	BN2-1504*	—								3.08
2	.250	BN2004*	—	2.75	3.50	.780	2.548-18	R50-3	8,000 lbs	40,000 lbs	3.04
2 1/4	.250	BN2204*	—	3.37	3.00	1.56	3.137-12	R2202-3	12,800 lbs	64,000 lbs	3.70
2 1/2	.250	BN2504*	—	3.37	3.00	1.56	3.137-12	R2202-3	16,000 lbs	80,000 lbs	3.90
2 3/4	.250	BN2704*	—	4.00	4.00	1.75	3.625-12	R2501-3	20,000 lbs	100,000 lbs	4.20
3	.250	BN3004*	—	4.00	4.00	1.75	3.625-12	R2501-3	23,000 lbs	115,000 lbs	4.50

† Load ratings based on using Thomson grease.. See page 147.  
 \* Non-stock item

## Lead Screws

For Acme Style Rolled Thread - 3/16" to 1/2" Diameter

NOMINAL MAJOR DIAMETER	LEAD	PRECISION PREFIX	STANDARD PREFIX	BS&A PART NO.	AVAIL IN LEFT HAND	MATERIAL	ROOT DIAMETER	RECOMMENDED BEARING
3/16"	0.050	SPR	SRA	1820	L	STAINLESS STEEL	0.12	N/A
1/4"	0.050	SPR	SRA	2520	L	STAINLESS STEEL	0.19	4mm
	0.063			2516	L		0.17	
	0.250			4-2516			0.17	
	0.500	N/A		7-2516			0.16	
5/16"	0.083	SPR	SRA	3112	L	STAINLESS STEEL	0.22	4mm
	0.167			2-3112			0.20	
	0.250			2-3108S			0.22	
	0.500			4-3108S			0.21	
3/8"	0.0625	SPR	SRA	3716	L	STAINLESS STEEL	0.30	4mm
	2mm			37x2M	L		0.28	
	0.083			3712	L		0.28	
	0.100			3710	L		0.26	
	0.125			3708S	L		0.29	
	0.167			2-3712S			0.31	
	0.200			2-3710			0.26	
	0.250			2-3708S	L		0.29	
	0.375			4-3711	L		0.27	
	0.500			4-3708S	L		0.27	
	1.00	N/A		5-3705			0.24	
	1.20			5-3704			0.24	
	10mm	2mm		SPT	SRT		10x2M	
3mm		10x3M	L			0.25		
6mm		SPR	SRA	4-10x1.5M		0.31		
20mm				6-10x3.3M		0.30		
7/16"	0.125	SPR	SRA	2-4316		STAINLESS STEEL	0.35	6mm
	0.250			2-4308S			0.36	
	0.500			4-4308S			0.33	
12mm	5mm	SPT	SRT	2-12x2.5M		STAINLESS STEEL	0.35	6mm
	10mm			4-12x2.5M			0.35	
1/2"	0.0625	SPR	SRA	5016		STAINLESS STEEL	0.41	6mm
	0.100			5010	L		0.37	
	0.200			2-5010			0.39	
	0.250			2-5008			0.38	
	0.500			4-5008			0.36	
	0.800	N/A		8-5010			0.37	
	1.000			8-5008			0.39	

## Lead Screws

### Acme Style Rolled Thread - 5/8" to 3" Diameter

NOMINAL MAJOR DIAMETER	LEAD	PRECISION PREFIX	STANDARD PREFIX	BS&A PART NO.	AVAIL IN LEFT HAND	MATERIAL	ROOT DIAMETER	RECOMMENDED BEARING
5/8"	0.100	SPR	SRA	6210	L	Stainless Steel	0.52	8mm
	0.125			6208S	L		0.52	
	—	—		—	—		—	
	0.200	SPR		2-6210			0.52	
	0.250			2-6208S			0.52	
	0.500			4-6208			0.48	
16mm	4mm	N/A	SRT	16 x 4M	L	Stainless Steel	0.45	8mm
3/4"	0.100	SPR	SRA	7510	L	Stainless Steel	0.63	12mm
	0.125			7508	L		0.61	
	0.167			7506	L		0.56	
	0.200	N/A		7505	L		0.53	
	0.500			5-7510			0.62	
	1.000			8-7508			0.61	
	2.000			10-7505†	L		0.59	
20mm	4mm	SPT	SRT	20 x 4M	L	Stainless Steel	0.61	12mm
24mm	5mm	SPT	SRT	24 x 5M	L	Stainless Steel	0.73	12mm
1"	0.100	SPR	SRA	1010	L	Stainless Steel	0.88	12 to 20mm
	0.125	SPR		1008	L		0.86	12 to 20mm
	0.200	SPR		1005	L		0.78	12mm
	0.250	N/A		1004	L	Carbon Steel	0.72	12mm
	0.500			5-1010		Stainless Steel	0.88	12 to 20mm
	1.000			10-1010		Stainless Steel	0.88	12 to 20 mm
1 1/4"	0.200	N/A	RA	1205	L	Low Carbon Steel	1.03	20mm
	0.250			1204	L		0.98	
1 1/2"	0.200	N/A	RA	1505	L	Low Carbon Steel	1.28	25mm
	0.250			1504	L		1.23	
	0.370			1503			1.11	
	0.500			2-1504			1.23	
2"	0.250	N/A	RA	2004	L	Low Carbon Steel	1.73	*
2 1/4"	0.250	N/A	RA	2204	L		1.98	*
2 1/2"	0.250	N/A	RA	2504	L		2.23	*
2 3/4"	0.250	N/A	RA	2704	L		2.48	*
3"	0.250	N/A	RA	3004	L		2.73	*

† Nominal O.D. is .734"

## VEE Thread Screws

Burnished Finish  
303 Stainless Steel

- Some sizes available in 1018 Steel
- Matching Supernuts and Left Hand Screws on special request
- Lead Accuracy is .015 in/ft

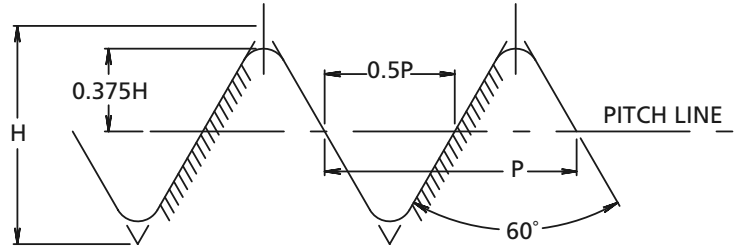

DIAMETER	LEAD	SIZE	PART NO.	RECOMMENDED BEARING
6mm	1mm	6 x 1	SV6x1	4mm
1/4"	.0125	1/4-80	SV2580	4mm
	.0208	1/4-48	SV2548	
	.0250	1/4-40	SV2540	
	.0278	1/4-36	SV2536	
	.0313	1/4-32	SV2532	
	.0357	1/4-28	SV2528	
	.0417	1/4-24	SV2524	
	.0500	1/4-20	SV2520	
3/8"	.0250	3/8-40	SV3740	4 or 6mm
	.0313	3/8-32	SV3732	
	.0417	3/8-24	SV3724	
	.0500	3/8-20	SV3720	
	.0625	3/8-16	SV3716	
	.0833	3/8-12	SV3712	
1/2"	.0250	1/2-40	SV5040	6 or 8mm
	.0333	1/2-30	SV5030	
	.0500	1/2-20	SV5020	
	.0625	1/2-16	SV5016	
	.0769	1/2-13	SV5013	

## Miniature Ball Screw Assemblies



Danaher Motion offers a wide selection of smooth and efficient precision miniature ball screws. Thomson miniature ball screws are designed for a cost effective solution in a small envelope. Shaft diameters range from 4mm to 14mm with maximum lengths from 100mm to 700mm and lead accuracies of 52 micron per 300mm.

- Smooth and efficient
- Wide selection of leads available
- Small envelope
- Cost effective precision rolled solution

### Material

Item	Material	Heat Processing	Hardness
Screw Shaft	4150 Steel	Induction Hardened	HRC 58-62
Nut	4150 Steel	Carbuerized	HRC 58-62

### Miniature Ball Screw Product Availability

	Lead (mm)									
	1	2	4	5	6	8	10	12	15	20
4	•									
5			•							
6	•				•					
8	•	•		•		•		•		
10		•					•		•	•
12		•								
13								•		•
14		•	•							

### Screw Precision and Axial Play

Screw Diameter	Accuracy	Axial Backlash
4 to 14mm	$V_{300p} = 52$ microns	20 microns

\*  $V_{300p}$  = Permissible travel variation within 300mm travel

## Precision Miniature 4mm to 14mm Diameter

### Type A - End Cap Design

The end-cap type ball recirculation system allows the nut length to be reduced and minimizes the outer diameter. No return mechanism protrudes outside the nut body diameter. Double flats on the flange make the unit ideal for use in small spaces.

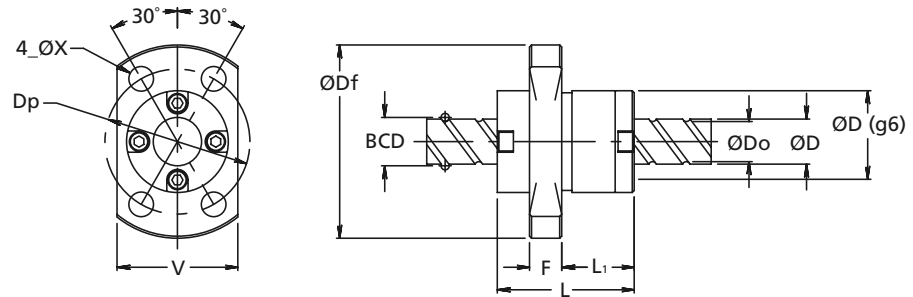

MODEL NUMBER	SCREW SHAFT OD	LEAD (mm)	BALL DIA. (mm)	MAX THREADED LENGTH (mm)	SUGGESTED BEARING SIZE (mm)	SCREW ROOT DIA. (mm)	LOAD RATING (N)	
							C <sub>a</sub> (DYNAMIC)	C <sub>oa</sub> (STATIC)
PRM0401	4	1	0.8	100	N/A	3.3	560	790
PRM0504	5	4	0.8	220	N/A	4.3	470	720
PRM0601	6	1	0.8	265	4	5.3	680	1200
PRM0606	6	6	1.0	265	4	5.2	870	1450
PRM0801	8	1	0.8	360	6	7.3	780	1650
PRM0802	8	2	1.59	360	6	6.6	2400	4100
PRM0805	8	5	1.59	360	6	6.6	1850	3000
PRM0808	8	8	1.59	360	6	6.7	2200	3800
PRM0812	8	12	1.59	360	6	6.7	2200	4000
PRM1002	10	2	1.59	355	6	8.6	2700	5300
PRM1010	10	10	2.0	405	6	8.4	3300	5900
PRM1015	10	15	2.0	405	6	8.4	3300	6400
PRM1020	10	20	1.59	405	6	8.7	2100	4000
PRM1202	12	2	1.59	395	8	10.6	3000	6400
PRM1312	13	12	2.38	700	8	11.0	5000	9900
PRM1320	13	20	2.38	700	8	11.0	5000	10700
PRM1402	14	2	1.59	445	8	12.6	3200	7500
PRM1404	14	4	2.38	445	8	11.8	5700	11600

Please contact the factory for sizes not listed.  
Units in millimeters. Divide by 25.4 to get inches.  
1N = 0.225 lbs.



## Precision Miniature 4mm to 14mm Diameter

### Type B - Return Plate Design

This design provides ball recirculation for low lead screws without return tubes protruding from the nut body. Coil type deflectors are used to divert the balls into the return system. Overall size is minimized and the flange has double flats as on type A.

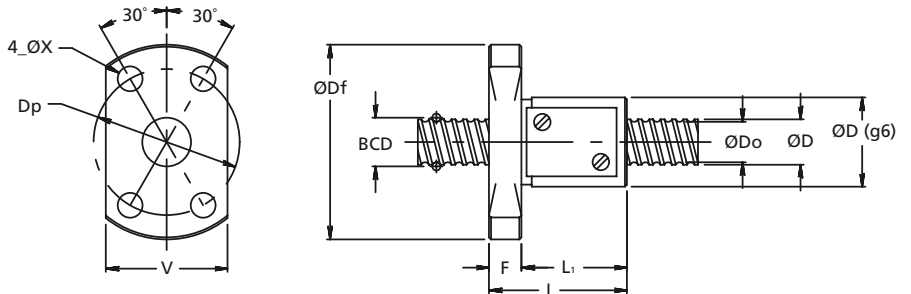

TYPE	NUT SIZE								MODEL NUMBER
	OUTSIDE DIAMETER D (mm)	FLANGE OUTSIDE DIAMETER D <sub>f</sub> (mm)	OVERALL LENGTH L (mm)	BODY LENGTH L <sub>1</sub> (mm)	FLANGE WIDTH F (mm)	FLANGE FLAT WIDTH V (mm)	BOLT CIRCLE DIAMETER D <sub>p</sub> (mm)	MOUNTING HOLE DIA. X (mm)	
B	11	24	17	13	4	15	18	3.4	PRM0401
B	12	24	22	18	4	16	18	3.4	PRM0504
B	13	26	17	13	4	16	20	3.4	PRM0601
A	14	27	17	8	4	16	21	3.4	PRM0606
B	16	29	17	13	4	18	23	3.4	PRM0801
B	20	37	24	19	5	22	29	4.5	PRM0802
B	18	31	28	24	4	20	25	3.4	PRM0805
A	18	31	20	10	4	20	25	3.4	PRM0808
A	18	31	27	17	4	20	25	3.4	PRM0812
B	23	40	24	19	5	25	32	4.5	PRM1002
A	23	40	24	13	5	25	32	4.5	PRM1010
A	23	40	33	22	5	25	32	4.5	PRM1015
A	20	37	23	13	5	22	29	4.5	PRM1020
B	25	42	24	19	5	27	34	4.5	PRM1202
A	28	45	30	17	5	30	37	4.5	PRM1312
A	28	45	43	29	5	30	37	4.5	PRM1320
B	26	45	25	19	6	28	36	5.5	PRM1402
B	30	49	33	27	6	32	40	5.5	PRM1404

Units in millimeters. Divide by 25.4 to get inches.

**NOTES:**



## Ball Screws, Ball Splines and Components



### Danaher Motion - First and Foremost in Linear Motion Applications

Danaher Motion ball screw assemblies and ball spline assemblies provide trouble-free operation in more applications than any other ball screw manufacturer. Our Thomson ball screws have become the standard for precise, controlled linear motion in commercial and military aircraft, machine tools, automated assembly equipment, material and nuclear fuel handling systems, medical equipment, office machines and agricultural machinery. Our expertise begins with engineers who understand that your linear motion needs may be unique.

Danaher Motion quality assurance gives you the most comprehensive examination of component materials and processes in the industry. We maintain all critical testing and inspection capabilities in house, along with our own heat-treating, plating and carburizing facilities to provide you with the most reliable ball screw products from a single, cost-effective source.

### Selecting Your Ball Screw

The ball screw section of this catalog is divided into both inch and metric sections, thus further segmented by accuracy class of the ball screw, Precision, Precision Plus and FineLine.

To assist you in selecting the most appropriate ball screw for your application, begin by reviewing the product selection overview on page 46 and 106, or go to the specific precision class section for product specification/selection information.

If you need assistance in selecting the right ball screw for your application, call our experienced application engineers at 1-800-554-8466.

## Inch Ball Screws

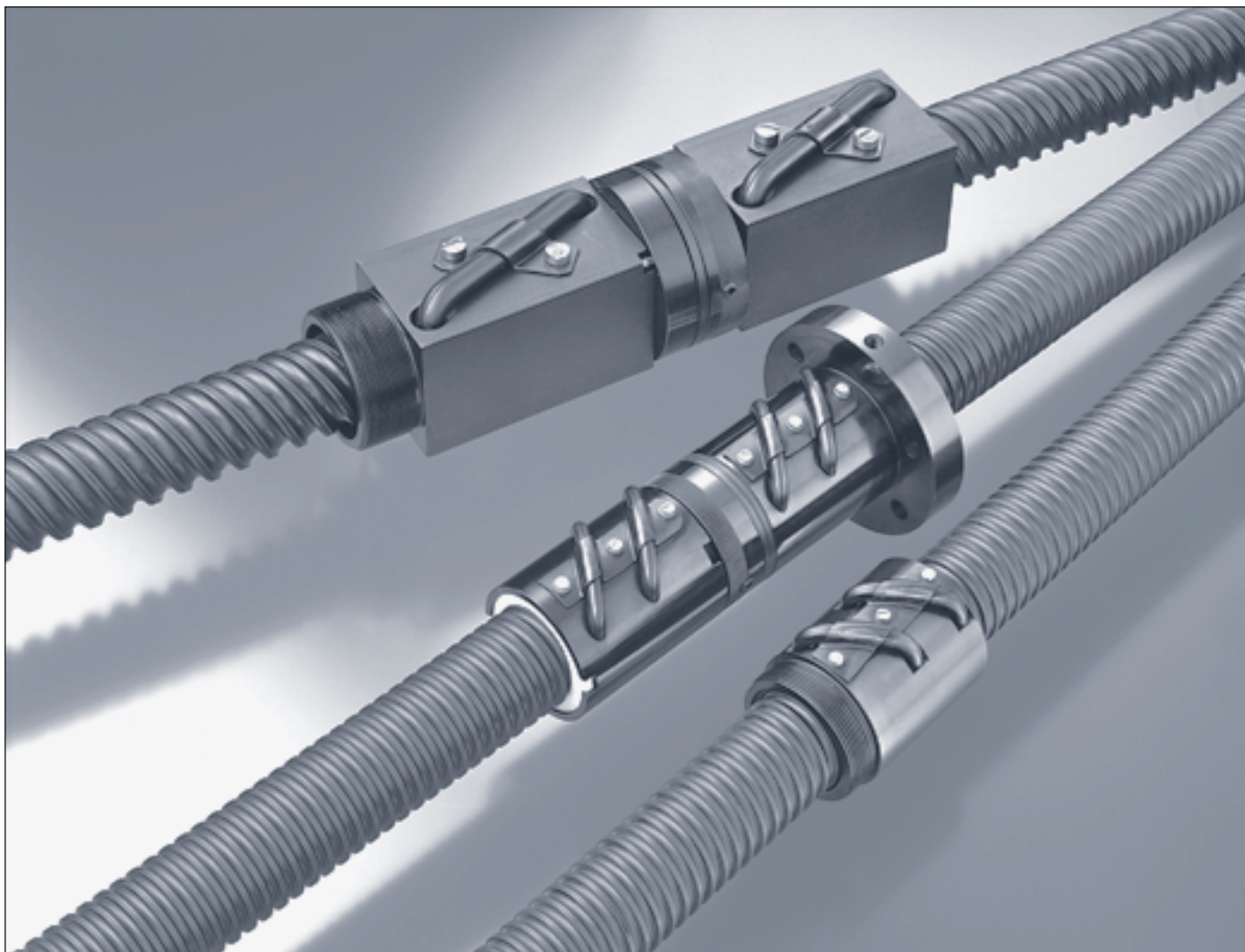

- Precision
- Precision Plus

If your design calls for precise linear motion, Danaher Motion has the answer to your needs. We offer a full range ball screws and ball splines plus engineering expertise and sales and service nationwide. The next several pages give you a preview of the products and actuation solutions we can provide.

## 1. Precision Ground Thread Ball Screws

Thomson custom and standard Precision Plus ball screw assemblies give you the most precise actuation because of ground thread lead accuracies of .0005 in./ft. travel. Efficiency ratings exceed 90%. Their anti-friction operation offers the most reliable performance and uniform feed under varying loads. You can select from a full range of diameters up to 2.50" lengths to match your application. See page 96-102.

## 2. Ball Splines

Thomson ball splines are torque resistant linear motion assemblies. They provide high-speed, anti-friction, linear motion travel while subject to torsional loads ranging from 600 to 200,000 lb.-in., depending on size.

Unlimited rolling travel is achieved because the balls travel through a return circuit. Typical uses include robot and remote handling systems, helicopter rotor couplings, and nonswiveling telescoping struts. See page 139-146.

## 3. Precision Non-preloaded Ball Nuts (SBN™)

Using rolled thread screws, assemblies using these ball nuts provide you with a low cost alternative to assemblies with more precise ground thread ball screws. They have a lead accuracy of .004 in./ft. travel and minimal backlash. Precision assemblies are widely used in conventional tables and slides, robotics, valve actuation and medical equipment. Nominal diameters range from .187 to 6.00 in. in lengths to match your application. See page 62-68.

## 4. Precision Preloaded I (SEL™)

Precision Preloaded I standard rolled thread ball nuts are adjustable preloaded nuts on a rolled thread ball screw that provide zero backlash and increased system stiffness. They operate with a lead accuracy of .004 in./ft. travel and feature a serrated center nut for each preload after installation. These assemblies are available in nominal shaft diameter sizes .631 to 1.500 in. and give you the performance you need in non-critical actuation applications. See page 62-68.

## 5. Precision Preloaded II (SAR)

These rolled thread ball nuts also allow you to set the preload by simply rotating the serrated nut between the two ball nuts. This feature gives you a rolled thread assembly that can be used where zero backlash is required. The cost effectiveness of the Precision Preloaded II assembly permits major savings in N/C machine tool and other applications. They are available in nominal shaft diameter sizes from .631 to 3.00 in. See page 62-68.

## 6. Precision Rolled Thread Screws

Precision rolled thread screws can be produced in nominal diameters from .187 in. to 12 in. and standard lengths up to 20 ft. Screw threads are rolled for best performance at low cost. Ends are available machined for bearings, gears or pulleys. See page 62-68.

## 7. Ball Screw Assembly Components

Danaher Motion has a complete line of components such as support blocks, wipers, and flanges to fit your particular application needs. In addition, shaft adapters and extensions, and shaft end machining is available for specific requirements. See page 62-68.

Performance Ranges	Precision Class			
	.004 in./ft. lead accuracy standard (.002 in./ft. available) (.001 in./ft. available)			.0005 in./ft. lead accuracy standard  (.0002 in./ft. available)
Series	Precision (non-preloaded) (SBN™) Inch .187 x .050	Precision (preloaded) (SEL™) Inch .631 x .200	Precision (preloaded) (SAR™) Inch .631 x .200	Precision Plus (preloaded) (SSP) Inch .500 x .200
Dia. x Lead	to 6.000 x 1.000	to 1.500 x .250	to 3.000 x .660	to 2.500 x .500
Backlash	.001 - .002	zero	zero	zero
Rated Load	5 lb/10 <sup>6</sup> rev to 160,000 lb/10 <sup>6</sup> rev	778 lb/10 <sup>6</sup> rev to 7,560 lb/10 <sup>6</sup> rev	778 lb/10 <sup>6</sup> rev to 44,316 lb/10 <sup>6</sup> rev	426 lb/10 <sup>6</sup> rev to 24,000 lb/10 <sup>6</sup> rev
Max. Static Load	75 lbs to 750,000 lbs	6,384 lbs to 34,662 lbs	6,384 lbs to 271,733 lbs	1,500 lbs to 140,000 lbs
Catalog Pages	62-68	62-68	62-68	96-102

Thomson products are engineered to world class performance standards, so that you can specify them worldwide. This Engineering Section provides charts, formulas and technical information for:

- Load considerations for horizontal and vertical mounted applications
- Ball screw life
- Operating speeds
- Column stiffness

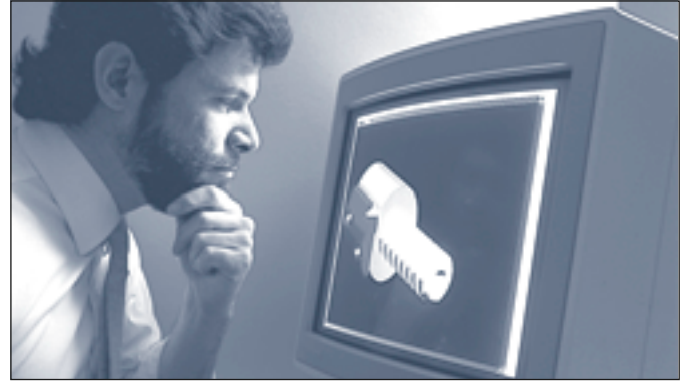

## Design Formulas

These formulas allow you to calculate a number of important factors which govern the application of Thomson ball screws.

### 1. Equivalent Operating Load

$$F = \sqrt[3]{q_1 (F_1)^3 + q_2 (F_2)^3 + q_3 (F_3)^3 + \dots + q_n (F_n)^3}$$

- $q_n$  = Proportion of Stroke or Cycle at  $F_n$
- $F_n$  = Increment of Load (lbf)
- $F$  = Equivalent Operating Load (lbf)

### 2. Ball Screw Life (L)

$$L = \left(\frac{C}{F}\right)^3 \times 10^6 \text{ inches or } L_h = \frac{L}{n_m \times 60}$$

- $C$  = Rated Dynamic Load Capacity (lbf)
- $F$  = Equivalent Operating Load (lbf)
- $L$  = Life in Inches
- $L_h$  = Life (hours)
- $n_m$  = Average Speed (in. x min. <sup>-1</sup>)

### 3. Rotational Speed Required for a Specific Linear Velocity

$$n = \frac{\text{Travel Rate (in. x min.}^{-1}\text{)}}{\text{Lead (in.)}}$$

- $n$  = rpm

### 4. Machine Service Life

After ball screw life (L) is calculated, apply it to the following formula to determine machine service life.

$$\text{Machine Service Life (in years)} = \frac{L_h}{(\text{machine operating hours}) \cdot (\text{days/year}) \cdot \left(\frac{\text{ball screw operating hours}}{\text{machine operating hours}}\right)}$$

### 5. Torque

a. Driving torque:  $T_d = \frac{F \times P}{2\pi e} = 0.177 \times F \times P$  (lbf x in.)

- $F$  = Equivalent Operating Load (lbf)
- $P$  = Lead (in.)
- $e$  = Efficiency = 0.90
- $T_d$  = Driving Torque
- $T_b$  = Backdrive Torque

b. Backdrive torque:  $T_b = \frac{F \times P \times e}{2\pi} = 0.143 \times F \times P$  (lbf x in.)  
 (conversion of linear to rotational motion)

### 6. Power

$$P_d = \frac{F \times P}{(2\pi) e} \times \frac{n}{6.302 \times 10^4} = \frac{F \times P \times n}{3.564 \times 10^5} \text{ (HP)}$$

- $P_d$  = Power (HP)
- $n$  = rpm

## 7. Critical Screw Speed

$$n_C = C_S \times 4.8 \times 10^6 \times \frac{d_r}{l^2}$$

$$n_S = n_C \times S$$

$n_C$  = Critical Speed (RPM)

$n_S$  = Safe Drive Speed

$d_r$  = Root Diameter (in.)

$l$  = Length between Bearing Supports (in.)

$S$  = Safety Factor (0.8 maximum)

$C_S$  = End Fixity Factor

End Fixity Factor		
End Supports		$C_S$
A	One end fixed, one end free	0.36
B	Both ends supported	1.00
C	One end fixed, one end supported	1.47
D	Both ends fixed	2.23

## 8. DN Factor (critical nut speed)

This factor is related to the speed of the ball rotating about the shaft, and is the product of

$$DN = d_0 n$$

where

$d_0$  = nominal shaft diameter (in)

$n$  = rotational speed of shaft (rpm)

We recommend a maximum DN of 3000 for tube transfer. Thomson can accommodate values greater than these by special design; please consult factory.

## Lead/Travel Accuracy Graph

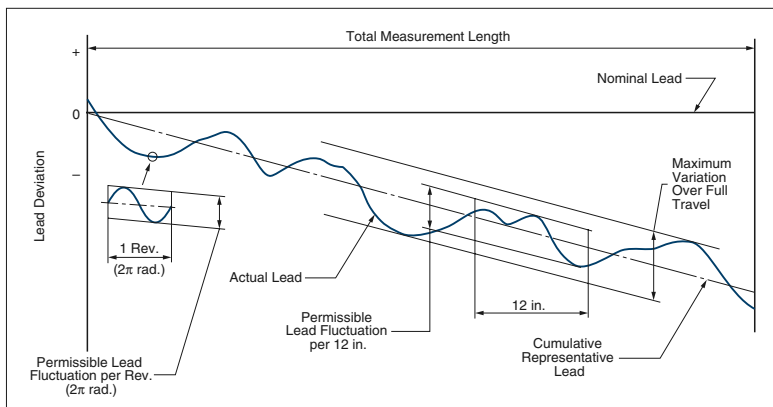

The graph to the left shows the various criteria recognized by standards organizations worldwide as key in determining the accuracy of ball screw assemblies.

Specified travel of the ball nut relative to the ball screw shaft, assuming no compensation for elongation caused by temperature rise or external load, is indicated by the horizontal line, **Nominal Lead**.

**Actual Lead** is the axial movement of the ball nut relative to the ball screw shaft.

**Cumulative Representative Lead** is the straight line illustration of actual travel obtained by the least squares method. This line portrays the tendency of the Actual Lead.

## Inch Product Cumulative Lead Accuracy $\Delta P$ (in.<sup>-3</sup>)

Ball Screw Assembly	ISO Class	Accumulated lead deviation $\Delta P$ (in. <sup>-3</sup> ) over screw length L (in.):						
		12	24	36	48	60	80	120
Precision	1	.20	.31	.43	.51	.59	.71	1
Plus	3	.39	.63	.83	.95	1.14	1.38	2
	5	1	2	3	4	5	6.67	10
Precision	7	2	4	6	8	10	13.3	20
	9	4	8	12	16	20	26.7	40
	10	8	16	24	32	40	53.3	80

Travel fluctuations are shown as a finite measure of distance between two lines drawn parallel to the Representative Lead at various points described by the following:

- **Maximum Fluctuation** – the extreme band width variation over full travel length.
- **Permissible Lead Fluctuation** – band width of variation over 12 in. defined by the accuracy class designation of the screw shaft under evaluation.
- **Permissible Lead Fluctuation per Revolution (Wobble)** – the actual magnitude of fluctuation for one revolution (2π radians).



## Bearing Support Reference Drawings (End Fixity)

**Critical Speed** — That condition where the rotary speed of the assembly sets up harmonic vibrations. (Refer to Figure 1.) These vibrations are the result of shaft diameter, unsupported length, type of bearing support, position of the ball nut in the stroke, how the ball nut is mounted, the shaft or ball nut rpm, etc. (Note: Shaft vibrations may also be caused by a bent screw or faulty installation alignment.) The four end fixity drawings (A, B, C, and D) show the bearing configurations for supporting a rotating shaft. The selection chart for Travel Rate vs. Length on page 50, shows these same configurations at the bottom of the chart and factors in their effect on critical shaft speed for the unsupported screw length.

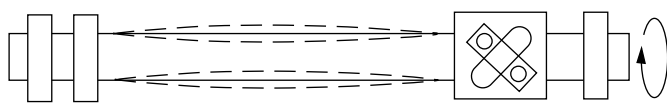
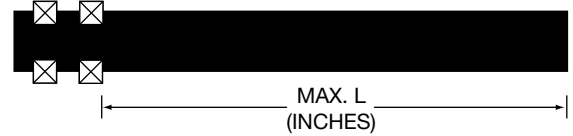

Figure 1

### Bearing Support vs. Speed (travel rate or rpm)

A – One end fixed, other end free



B – Both ends supported

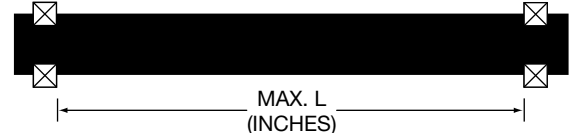

C – One end fixed, other end supported

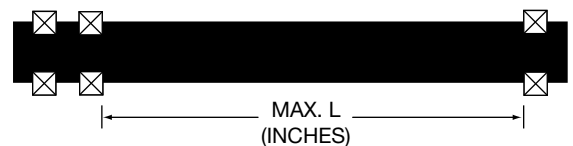

D – Both ends fixed

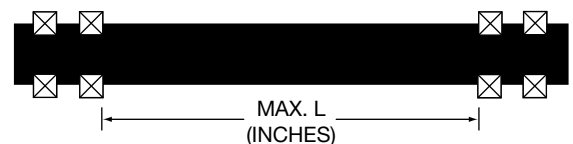

**Tension Loads** — Those loads where the force pulls on the bearing and its support. (Refer to Figure 2.) Where practical, applications should be designed to function with the load in tension to achieve the widest possible selection of screw sizes. Ball screws operating in both tension and compression may be preloaded between the support bearings or mounted per the guidelines under Compression Loads.

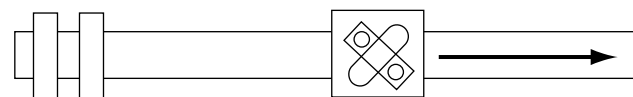

Figure 2

**Compression Loads** — Those loads where the force pushes on the bearing and its support. (Refer to Figure 3.) Compression loads tend to cause the screw shaft to bend. This normally requires a ball screw with a larger diameter than one for tension loading only. The four end fixity drawings (E, F, G, and H) show the bearing configurations for supporting a shaft subject to compression loads. The selection chart for Compression Load vs. Length, on page 54, shows these same configurations at the bottom of the chart and factors in their effect on the unsupported length of the screw for compression loads.

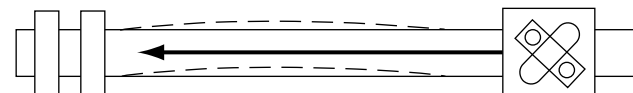

Figure 3

### Bearing Support vs. Compression Load on Screws

E – One end fixed, other end free



F – Both ends supported



G – One end fixed, other end supported

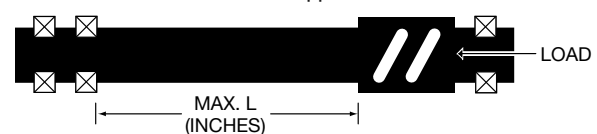

H – Both ends fixed



Note: The information in this guide for end fixity is based on the centers of the two bearings spaced apart by 1-1/2 times the root diameter of the screw.

## Acceptable Travel Rate† vs. Length for Screws

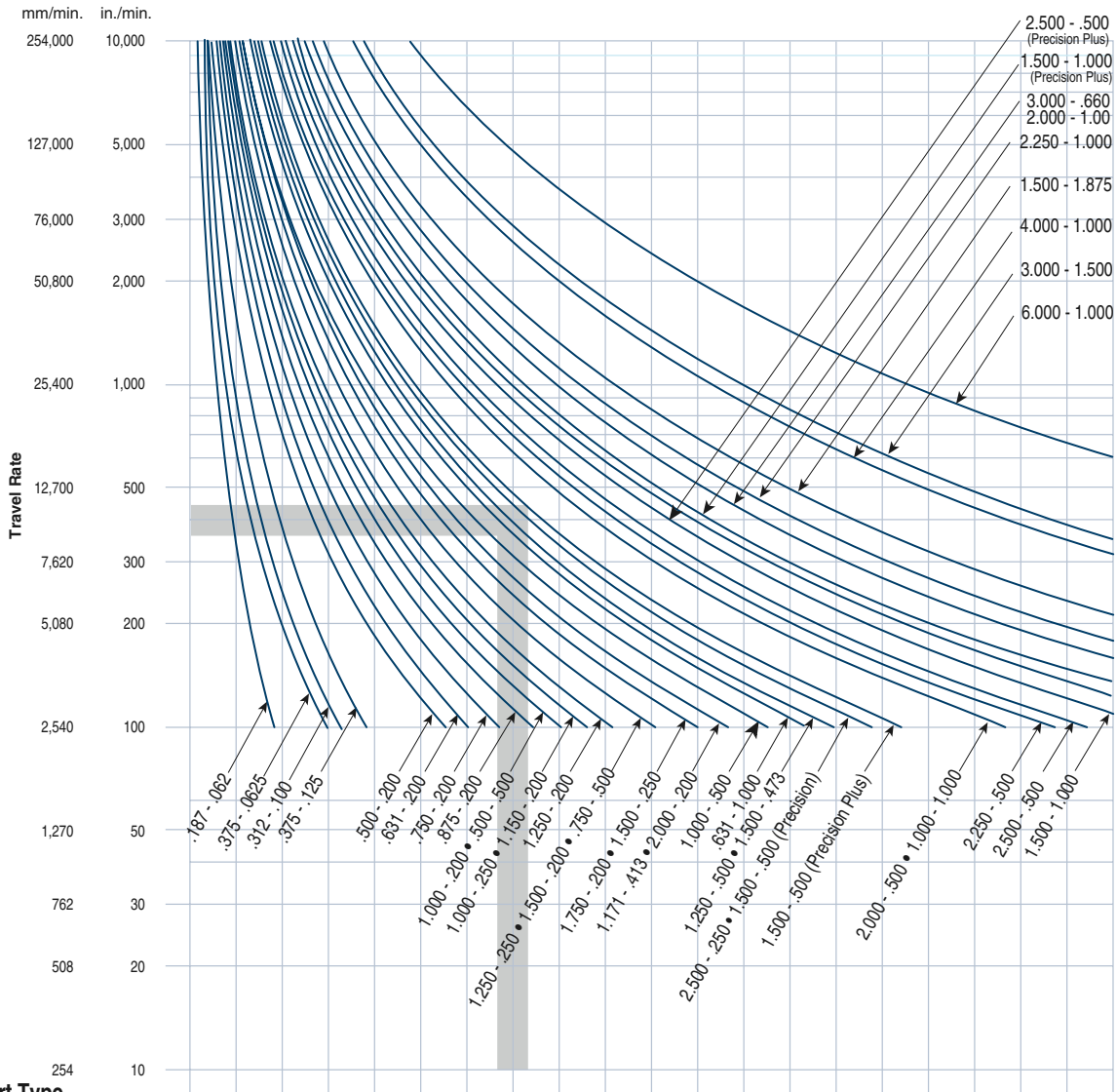

### End Support Type

End Support Type	Diagram	Inches	6	12	18	24	30	36	42	48	54	60	66	72	78	84	90	96	102	108	114	120
A	One end fixed, other end free	mm	152	304	457	609	762	914	1066	1219	1371	1524	1676	1828	1981	2133	2286	2438	2590	2743	2895	3048
B	Both ends supported	Inches	10	20	30	40	50	60	70	80	90	100	110	120	130	140	150	160	170	180	190	200
		mm	254	508	762	1016	1270	1524	1778	2032	2286	2540	2794	3048	3302	3556	3810	4064	4318	4572	4826	5080
C	One end fixed, other end supported	Inches	12	24	36	48	61	73	85	97	109	121	133	145	158	170	182	194	206	218	230	242
		mm	304	609	914	1219	1549	1854	2159	2463	2768	3073	3378	3683	4013	4318	4622	4927	5232	5537	5842	6146
D	Both ends fixed	Inches	15	30	45	60	75	90	105	119	134	149	164	179	194	209	224	239	254	269	284	298
		mm	381	762	1143	1524	1905	2286	2667	3022	3403	3784	4165	4546	4927	5308	5689	6070	6451	6832	7213	7594

Example: Travel rate of 400 in./min. (10160 mm/min.).

Unsupported length of 85 in. (2159 mm).

End fixity of one end fixed, other end supported.

All screws with curves which pass through or above and to the right of the plotted point are suitable for the example. The acceptable velocities shown by this graph apply to the screw shaft selected and are not indicative of the velocities attainable of all of the associated ball nut assemblies. Consult factory in high speed applications.

† 80% of critical speed

## Life Expectancy for Precision Non-Preloaded Ball Screw Assemblies

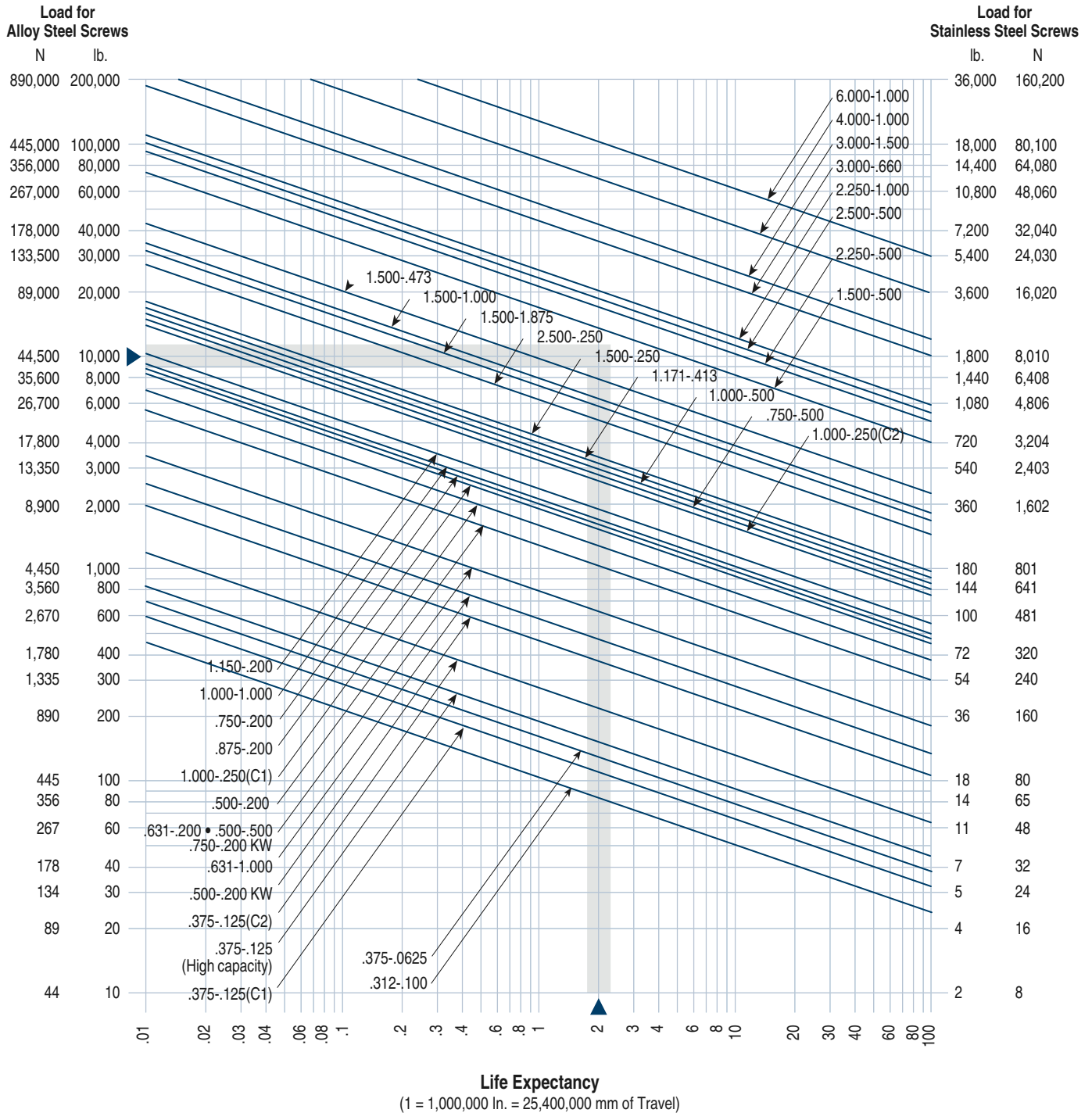

Example: Application life expectancy (total travel) desired is 2 million in. (50.8 million mm).  
 Normal operating load is 10,000 lb. (44,500 N).

All screws with curves which pass through or are above and to the right of the plotted point are suitable for the example. The suitable dynamic life expectancies shown in this graph are not to exceed the maximum static load capacity as given in the rating table for the individual ball nut assembly.

## Life Expectancy for Precision Preloaded Ball Screw Assemblies

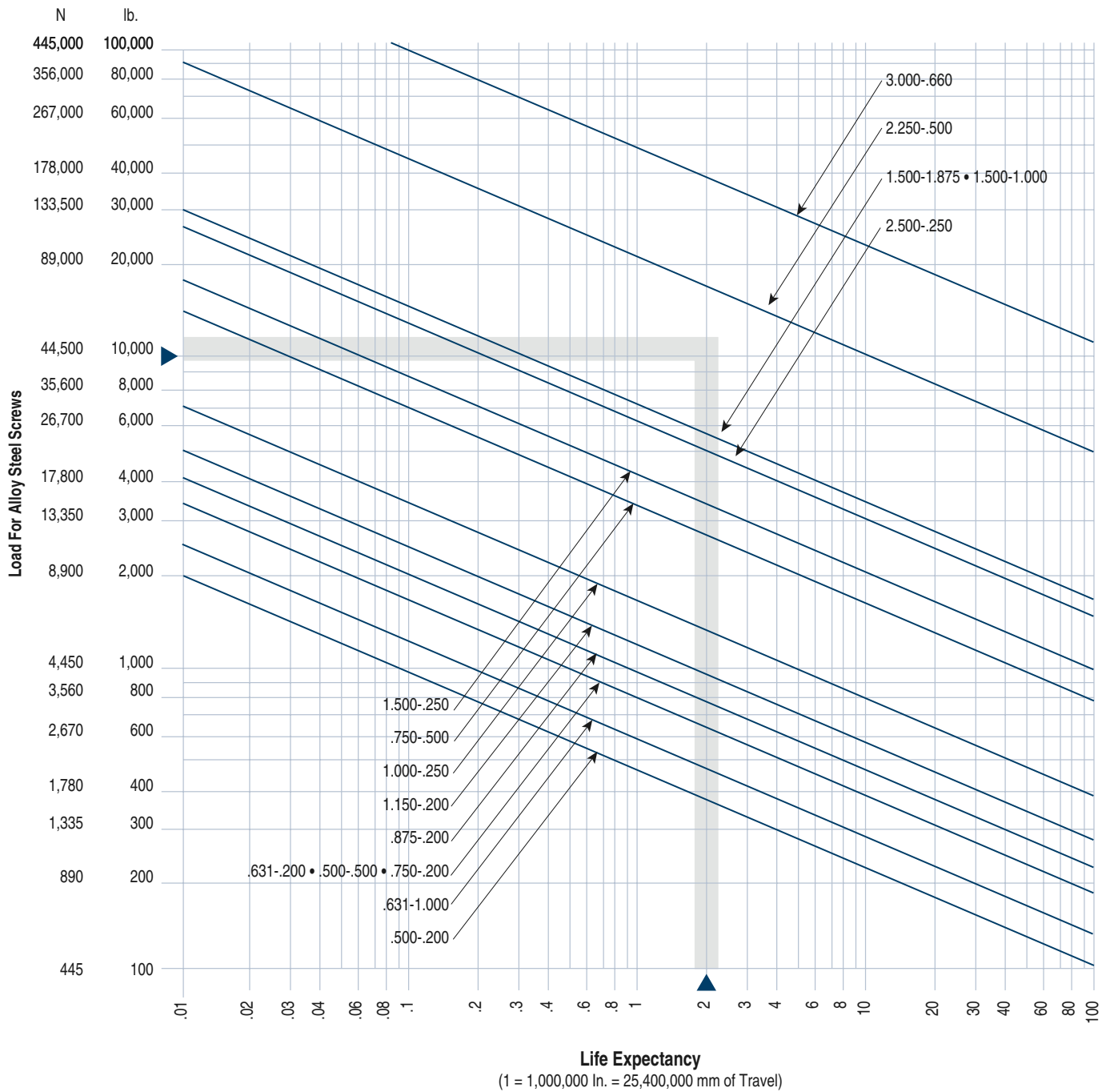

Example: Application life expectancy (total travel) desired is 2 million in. (50.8 million mm).

Normal operating load is 10,000 lb. (44,500 N).

All screws with curves which pass through or are above and to the right of the plotted point are suitable for the example. The suitable dynamic life expectancies shown in this graph are not to exceed the maximum static load capacity as given in the rating table for the individual ball nut assembly.

## Life Expectancy for Precision Plus Preloaded Ball Screw Assemblies

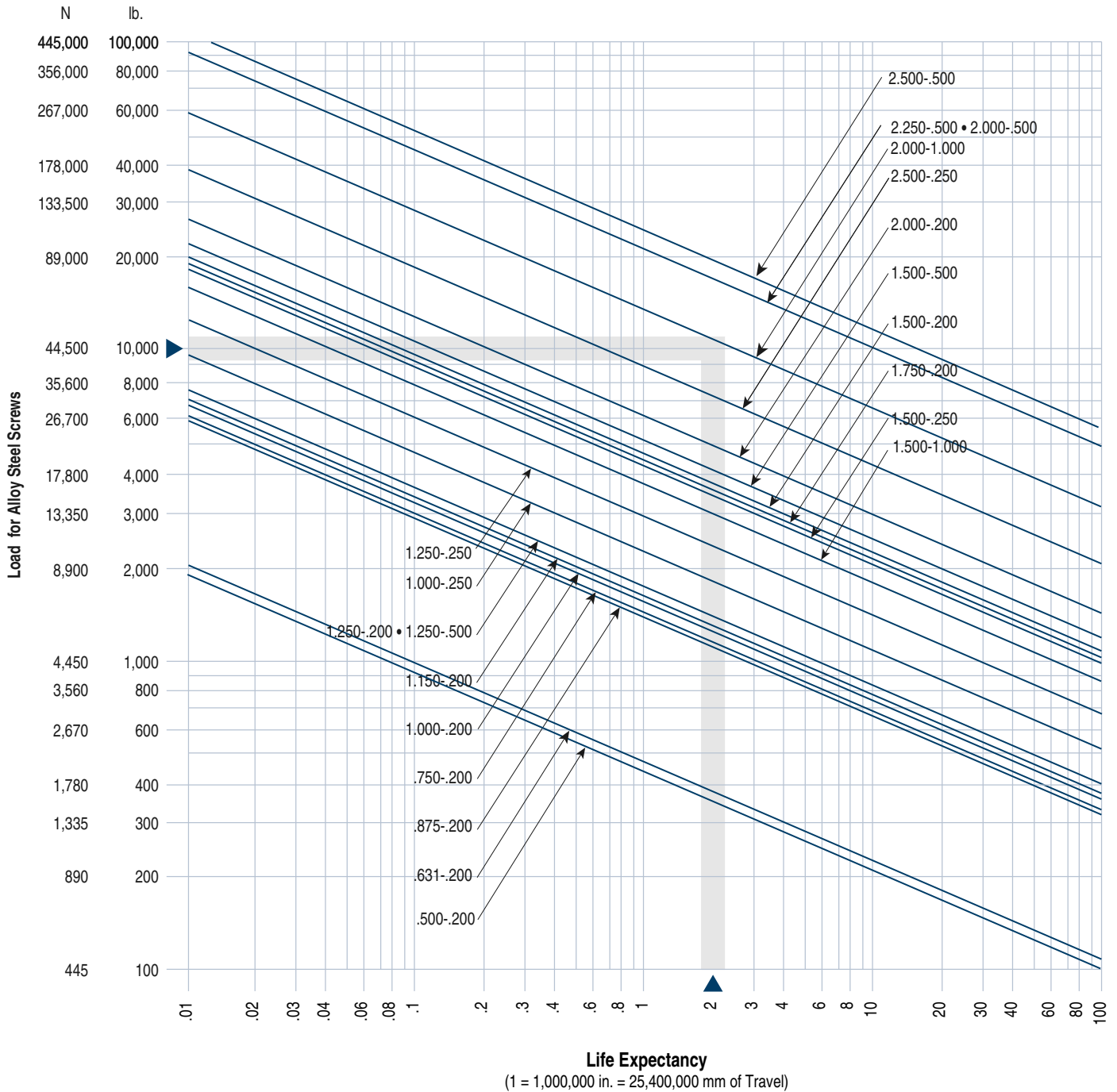

Example: Application life expectancy (total travel) desired is 2 million in. (50.8 million mm).  
 Normal operating load is 10,000 lb. (44,500 N).

All screws with curves which pass through or are above and to the right of the plotted point are suitable for the example. The suitable dynamic life expectancies shown in this graph are not to exceed the maximum static load capacity as given in the rating table for the individual ball nut assembly.

## Compression Load vs. Length for Designated Ball Screws

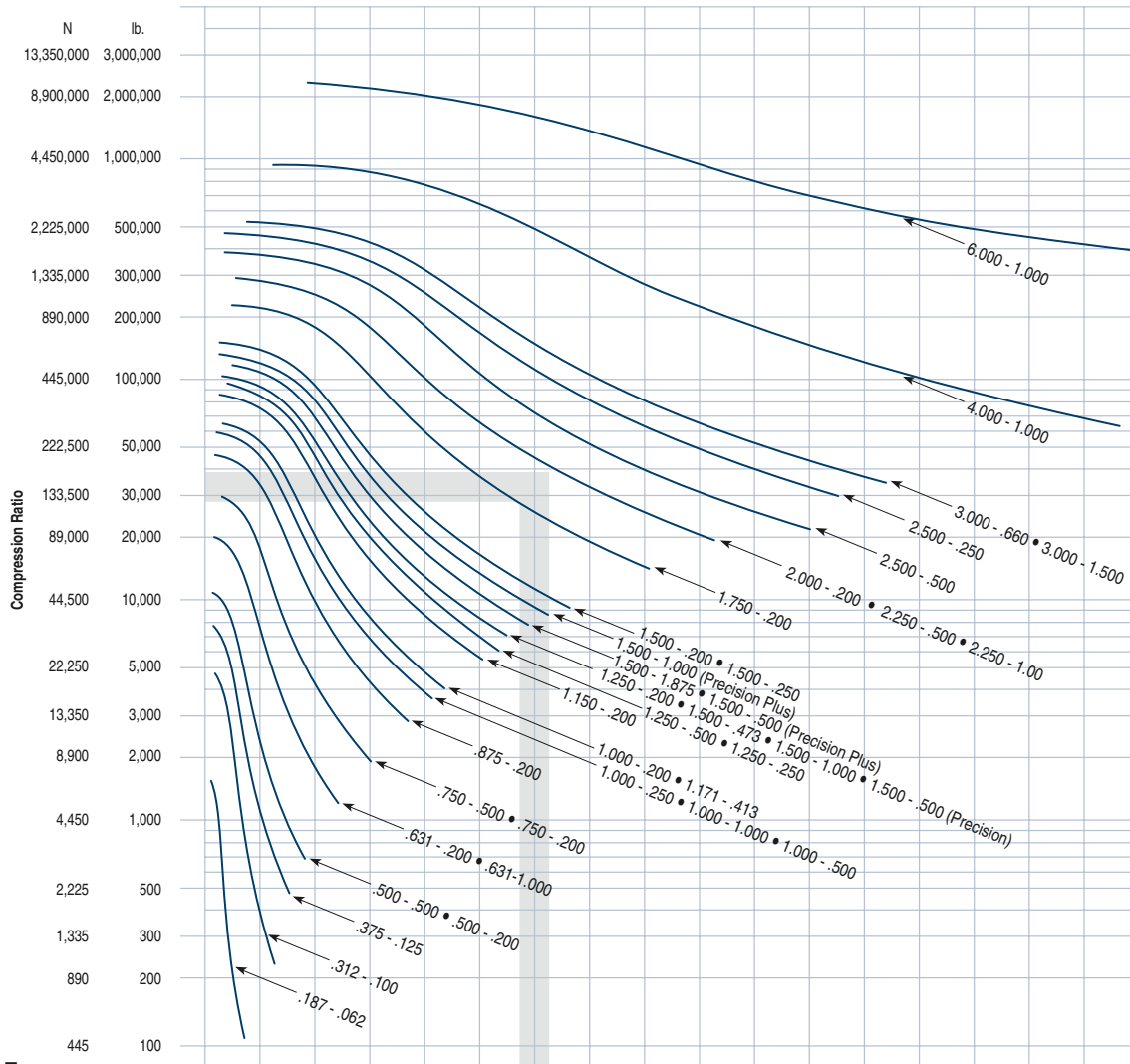

### End Support Type

End Support Type	Inches	5	10	15	20	25	30	35	40	45	50	55	60	65	70	75	80	85
<b>A</b> One end fixed, other end free	mm	127	254	381	508	635	762	889	1016	1143	1270	1397	1524	1651	1778	1905	2032	2159
<b>B</b> Both ends supported	Inches	10	20	30	40	50	60	70	80	90	100	110	120	130	140	150	160	170
	mm	254	508	762	1016	1270	1524	1778	2032	2286	2540	2794	3048	3302	3556	3810	4064	4318
<b>C</b> One end fixed, other end supported	Inches	14	28	42	57	71	85	99	113	127	141	156	170	184	198	212	226	240
	mm	356	711	1067	1448	1803	2159	2515	2870	3226	3581	3962	4318	4674	5029	5385	5740	6096
<b>D</b> Both ends fixed	Inches	20	40	60	80	100	120	140	160	180	200	220	240	260	280	300	320	340
	mm	508	1016	1524	2032	2540	3048	3556	4064	4572	5080	5588	6096	6604	7112	7620	8128	8636

Example: Maximum system load is 30,000 lb. (133,500 N).  
Length of 85 in. (2159 mm).  
End fixity of one end fixed, other end supported.

All screws with curves which pass through or above and to the right of the plotted point are suitable for the example.

The suitable compression loads shown in this graph are not to exceed the maximum static load capacity as given in the rating table for the individual ball nut assembly.

## Typical Ends

The typical ends shown below can be machined on all ball screws and ball splines. Specific dimensional data is provided in the chart. Shaded area represents the drive extension for a keyed drive coupling.

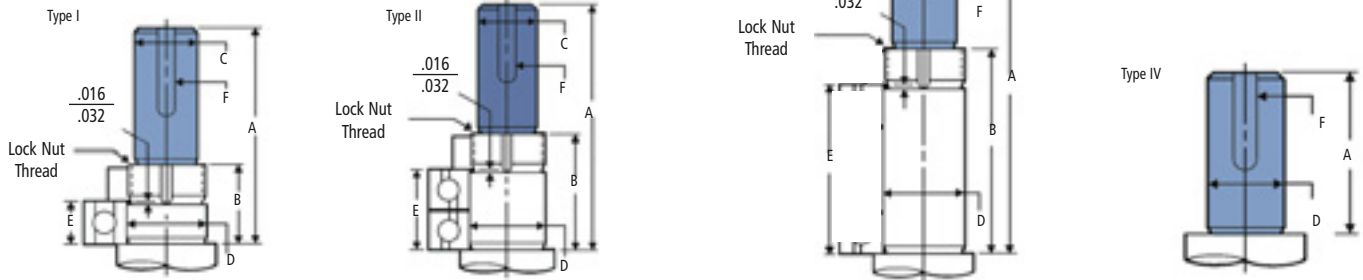

SCREW SIZE	ROOT Min. Dia. (Ball Screws)	Type I <sup>†</sup> Typical Journal for Single Bearings			Type II <sup>†</sup> Typical Journal for Duplexed Bearings			Type III <sup>†</sup> Typical Journal for Multiple Sets of Duplexed Bearings or Quick Mount Bearing Blocks				Dimensions Common to End Configurations Types I, II, and III						Type IV <sup>†</sup> Typical Journal for Pillow Block				
		A	B	E	A	B	E	A	B	E	Part No.	Standard Hardware						A	D	F		
												C	D	mm	F	L'k Nut	L'k Was				Ang Con Brg	
.187 .062	0.1400	1.360	0.360	0.156	1.516	0.516	0.312	1.828	0.828	0.624		.093	.1251				5-40		R2 Radial			
.375 .125	0.3000	1.900	0.650	0.276	2.176	0.926	0.552	2.728	1.478	1.104		.092	.1248									
.375 .062	.327											.187	.2757	7	1/16 x 1/32	1/4-20			#37 Radial			
.500 .200	0.3600	1.970	0.720	0.315	2.285	1.035	0.630	2.915	1.665	1.260	7828282	.250	.3544	9	3/32 x 3/64	5/16-24			#39 Radial			
.500 .500	0.3600	1.970	0.720	0.315	2.285	1.035	0.630	2.915	1.665	1.260	7828282	.249	.3541									
.631 .200	0.4800	2.110	0.810	0.394	2.504	1.204	0.788	3.292	1.992	1.576	7824154	.406	.4726	12	1/8 x 1/16	N-01	W-01	201		2.625	.5000	1/8 x 1/16
.631 1.000	0.4800	2.110	0.810	0.394	2.504	1.204	0.788	3.292	1.992	1.576	7824154	.405	.4723							2.625	.4995	x 1.500
.750 .200	.600 - .625	1.870	0.870	0.433	2.310	1.310	0.866	3.180	2.180	1.732	7824155	.500	.5908	15	1/8 x 1/16	N-02	W-02	202		2.620	.5625	1/8 x 1/16
.750 .500	0.580	1.870	0.870	0.433	2.310	1.310	0.866	3.180	2.180	1.732	7824155	.499	.5905							2.650	.5620	x 1.500
.875 .200	0.7350	2.233	0.918	0.472	2.705	1.390	0.944	3.649	2.334	1.888	7824156	.562	.6695	17	1/8 x 1/16	N-03	W-03	203		2.625	.6250	3/16 x 3/32
1.000 .200	0.8630	2.375	1.060	0.551	2.926	1.611	1.102	4.028	2.713	2.204	7824157	.561	.6692							2.719	.6245	x 1.500
1.000 .250	0.8200	2.375	1.060	0.551	2.926	1.611	1.102	4.028	2.713	2.204	7824157	.625	.7877	20	3/16 x 3/32	N-04	W-04	204		2.719	.7495	3/16 x 3/32
1.000 .500	0.820	2.375	1.060	0.551	2.926	1.611	1.102	4.028	2.713	2.204	7824157	.624	.7873							2.719	.7495	x 1.500
1.000 1.000	0.8200	2.375	1.060	0.551	2.926	1.611	1.102	4.028	2.713	2.204	7824157	.625	.7877	20	3/16 x 3/32	N-04	W-04	204		2.719	.7495	3/16 x 3/32
1.150 .200	1.0050	2.680	1.120	0.591	3.271	1.711	1.182	4.453	2.893	2.364	7824158	.624	.7873							2.844	.7495	x 1.500
1.171 .413	0.8700	2.375	1.060	0.551	2.926	1.611	1.102	4.028	2.713	2.204	7824157	.750	.9846	25	3/16 x 3/32	N-05	W-05	205		2.844	1.0000	1/4 x 1/8
1.250 .200	1.1130	2.680	1.120	0.591	3.280	1.710	1.181	4.440	2.880	2.362	7824158	.749	.9842							2.844	.9995	x 1.500
1.250 .500	1.0490	2.680	1.120	0.591	3.280	1.710	1.181	4.440	2.880	2.362	7824158	.625	.7877	20	3/16 x 3/32	N-04	W-04	204		2.844	.8745	3/16 x 3/32
1.500 .200	1.3470	2.970	1.160	0.630	3.600	1.790	1.260	4.860	3.050	2.520	7824159	.749	.9842	25	3/16 x 3/32	N-05	W-05	205		3.150	1.0000	1/4 x 1/8
1.500 .250	1.3200	2.970	1.160	0.630	3.600	1.790	1.260	4.860	3.050	2.520	7824159	1.000	1.1814	30	1/4 x 1/8	N-06	W-06	206		3.150	.9995	x 1.500
1.500 .500	1.2300	2.970	1.160	0.630	3.600	1.790	1.260	4.860	3.050	2.520	7824159	.999	1.1810							3.438	1.3125	5/16 x 5/32
1.500 .473	1.1400	2.680	1.120	0.591	3.271	1.711	1.182	4.453	2.893	2.364	7824158	1.1810								3.438	1.3120	x 1.750
1.500 1.000												1.000	1.1814	30	1/4 x 1/8	N-06	W-06	206		3.250	1.1875	1/4 x 1/8
1.500 1.875	1.1880	2.970	1.160	0.630	3.600	1.790	1.260	4.860	3.050	2.520	7824159	.999	1.1810							3.250	1.1245	1/4 x 1/8
1.750 .200	1.6130	3.650	1.460	0.906	4.556	2.366	1.812	6.368	4.178	3.624	7829554	.750	.9846	25	3/16 x 3/32	N-05	W-05	305		3.250	1.1245	1/4 x 1/8
2.000 .200												1.000	1.1814	30	1/4 x 1/8	N-06	W-06	206		3.250	1.1875	1/4 x 1/8
2.250 .500	1.8500	3.730	1.540	0.984	4.714	2.524	1.968	6.682	4.492	3.936	7824160	.999	1.1810							3.438	1.3125	5/16 x 5/32
2.250 1.000												1.375	1.5752	40	5/16 x 5/32	N-08	W-08	308		4.438	1.4995	x 2.500
2.500 .250	2.3200	4.560	1.680	1.063	5.623	2.746	2.126	7.749	4.872	4.252	7824161	1.374	1.5747							4.938	1.7500	3/8 x 3/16
2.500 .500	2.3200	4.560	1.680	1.063	5.623	2.746	2.126	7.749	4.872	4.252	7824161	1.750	1.9689	50	3/8 x 3/16	N-10	W-10	310		5.188	2.0000	1/2 x 1/4
3.000 .660	2.4800	5.560	1.875	1.221	6.781	3.096	2.442	9.223	5.538	4.884		1.749	1.9684							5.188	1.9995	x 3.000
3.000 1.500												1.750	1.9689	50	3/8 x 3/16	N-10	W-10	310		5.188	2.0000	1/2 x 1/4
4.000 1.000	3.3380	6.950	2.260	1.535	8.485	3.795	3.070	11.555	6.865	6.140		1.749	1.9684							7.250	2.4375	5/8 x 5/16
6.000 1.000	5.1430	8.596	3.346	2.284	10.879	5.629	4.567	15.446	10.196	9.134		2.250	2.3627	60	1/2 x 1/4	N-12	W-12	312		7.563	2.4365	x 4.688
												2.249	2.3621							7.563	2.9370	3/4 x 3/8
												3.000	3.1501	80	3/4 x 3/8	N-16	W-16	316		7.563	2.9360	x 4.688
												4.937	5.1188	130	1-1/2 x 3/4			326		15.500	4.9207	1-1/2 x 3/4
												4.936	5.1179								4.9197	x7.430

<sup>†</sup>Screw Size refers to all standard ball screws. For ball splines, root diameter limitations apply.  
<sup>††</sup>To provide for bearings with larger capacity than those available for these typical ends, adapters can be used to increase the diameter.



©2004 Danaher Motion. Printed in the U.S.A. The specifications in this publication are believed to be accurate and reliable. However, it is the responsibility of the product user to determine the suitability of Thomson products for a specific application. While defective products will be replaced without charge if promptly returned, no liability is assumed beyond such replacement.

**NOTES:**

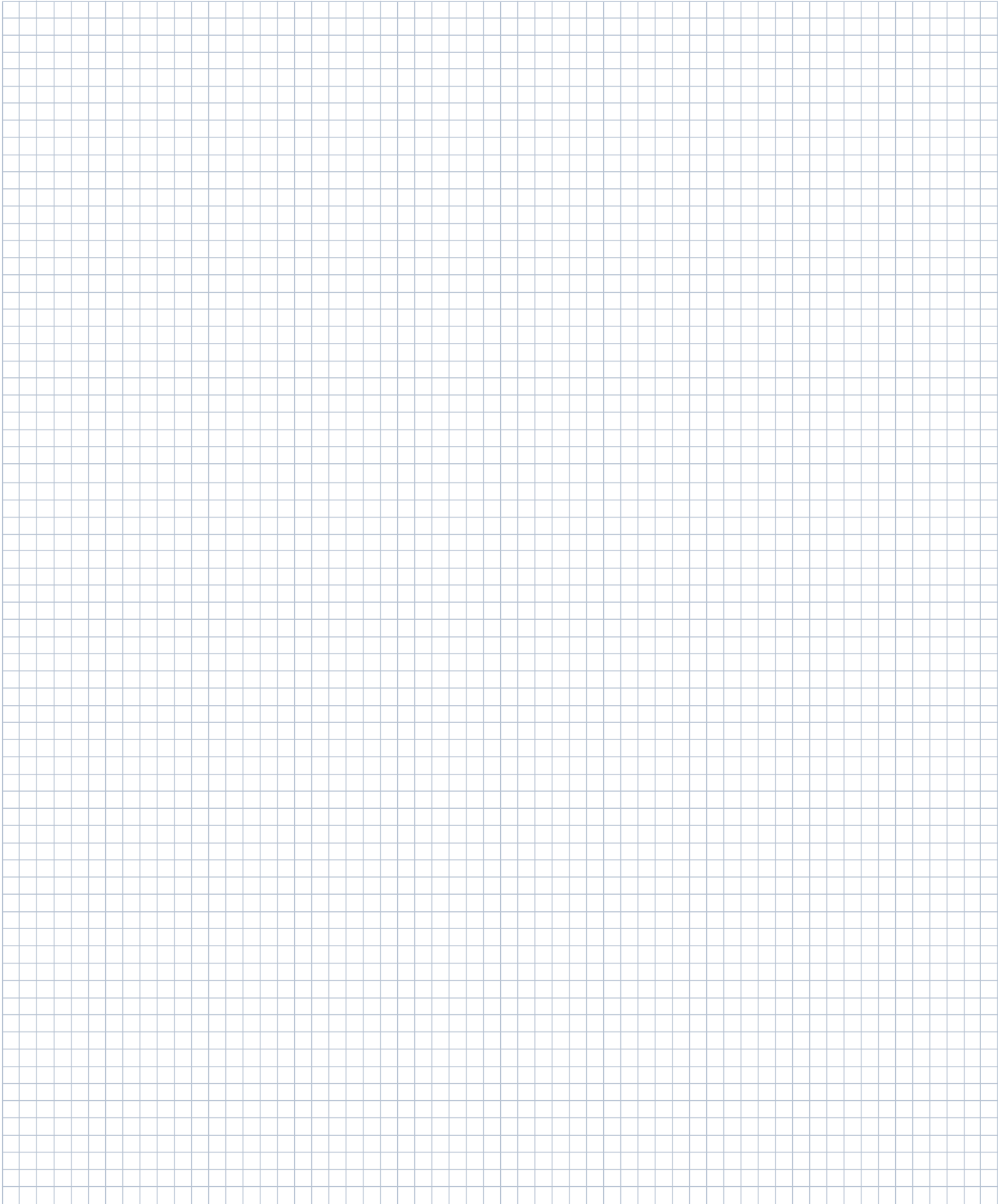



## Precision - Inch

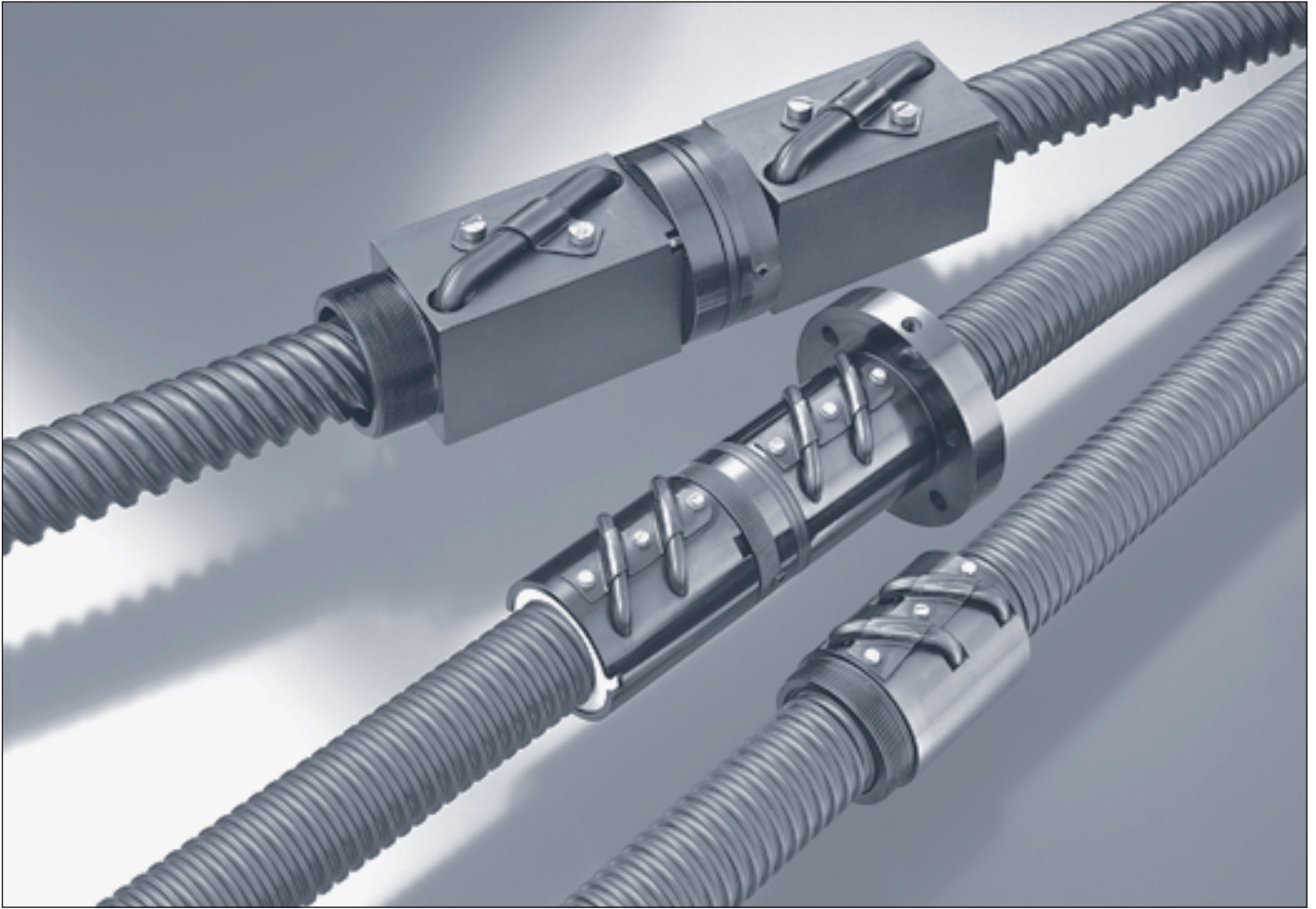

### Thomson Precision Ball Screws Offer:

- Availability in a full range of diameters, leads, and nut configurations, in either preloaded or non-preloaded types, all in industry standard envelopes.
- Over 90% efficiency with a constant low coefficient of friction. When replacing conventional actuation systems such as Acme screws, hydraulics, or pneumatics, they allow the use of smaller, less-expensive drive motors and reduce the need for auxiliary equipment.
- Dependable accuracy and repeatability at an economical price.
- A Gothic arch ball groove geometry that extends service life, reduces lash, and optimizes stiffness in preloaded assemblies.
- Optional wiper kits and end support blocks, which increase system efficiency and service life.
- Availability through over 1800 authorized Danaher Motion distributors worldwide.

## Precision Inch Product Availability

Lead (in)

	0.050	0.062	0.100	0.125	0.200	0.250	0.413	0.473	0.500	0.660	1.000	1.500	1.875
0.187	●	●											
0.312			●										
0.375		●		●									
0.500					●				●				
0.631					●						●		
0.750					●				●				
0.875					●								
1.000						●			●		●		
1.171							●						
1.500					●	●		●	●		●		●
2.250									●		●		
2.500						●			●				
3.000										●		●	

- = stocked size
- = on request

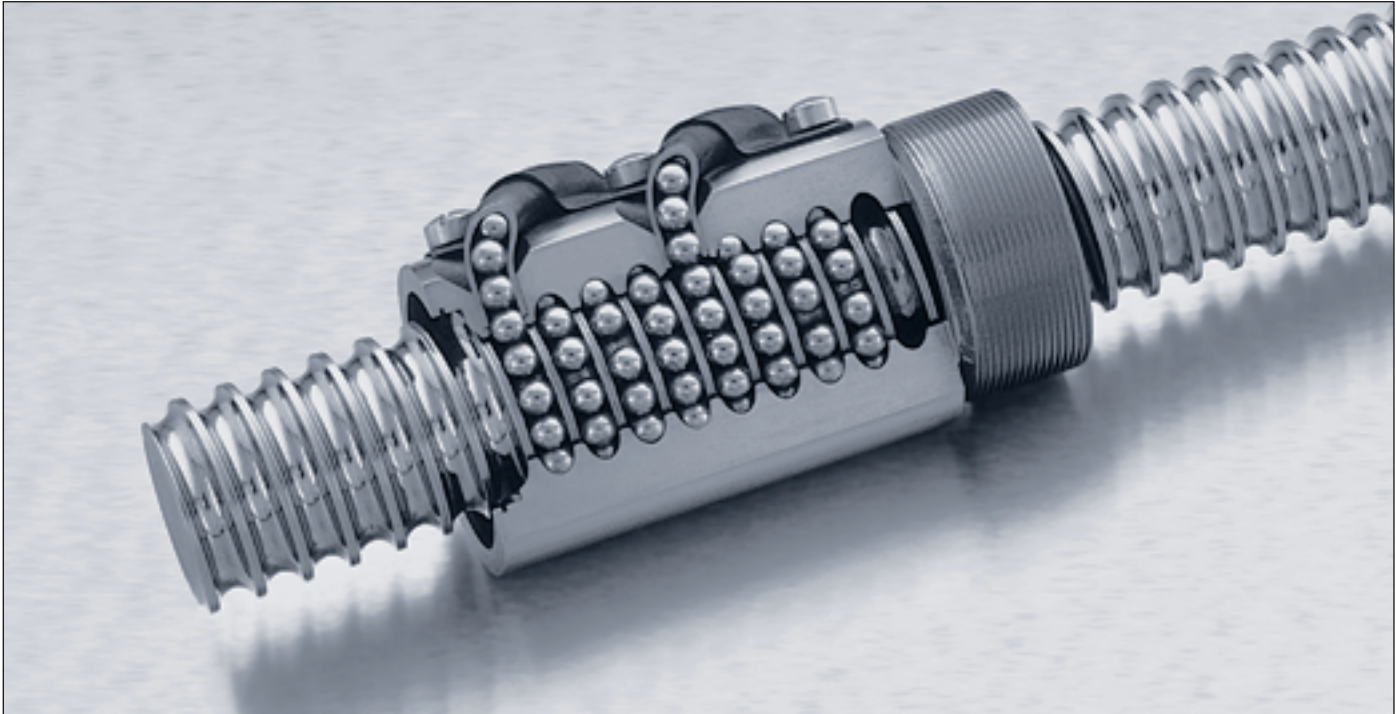

Each Thomson ball screw assembly consists of a screw (the inner race) with a precision helical groove, a nut (the outer race) with an internal groove, and precision steel balls that recirculate in the grooves between the screw and nut. This anti-friction design converts torque to thrust, or vice versa. As the screw or nut rotates, its mating component translates linearly.

## The Thomson Advantages

Ball screws are not all alike. Differences in material, design, and manufacturing, coupled with extensive inspection and applications support, are all factors that affect the performance and extend the life of your ball screw. That's why it's important to select your ball screw — and ball screw supplier — very carefully.

### Design

The Thomson thread form, "the Gothic Arch," maintains tighter contact angle control than other thread forms. This rigid control of contact angle results in:

- Low contact stresses which provide high load capacity and maximum predictable life
- Improved stiffness
- Minimal backlash accumulation in non-preloaded assemblies
- Long-lasting preload and consistent stiffness

Thomson ball screws also employ a durable external return ball recirculation system and a selection of specially designed replaceable seal/wiper designs that provide superior lubricant retention, while keeping out harmful contaminants.

### Performance

Thomson ball screw assemblies from Danaher Motion provide performance advantages that other ball screws just can't match.

These include:

- **Higher Dynamic Load Ratings**

While other companies manufacture ball screws to conform to theoretically calculated standards, our products reflect empirically derived performance and use values which result in, size for size, the highest dynamic load rating in the industry.

- **Longer Service Life**

Compared to competitive ball screws, our assemblies provide longer service life. This increased life is determined by the ratio of the Thomson dynamic load rating versus competitive rating raised to the third power.

**Example:**

$$\text{Life} = (C/F)^3 \times 10^6 \text{ in.}$$

	Competitor	Thomson
Maximum Capacity	4,141 lb.	5,360 lb.
Relative Capacity	1.0	1.29 vs. Competitor
Relative Life At Capacity Full Load	1.0 x 10 <sup>6</sup> in.	2.1 x 10 <sup>6</sup> in. vs. Base Line for Competitor (5,360 / 4,141) <sup>3</sup> x 10 <sup>6</sup>

The Thomson ball screw assembly provides 210% life expectancy or twice the life of the competitor's assembly in this example.

## Manufacturing

Danaher Motion maintains the most modern and complete ball screw manufacturing facility in the industry. In-house manufacturing capabilities include our proprietary heat treating and plating processes. Expert manufacturing, using the most modern equipment available, provides ball screws that set the standards for performance, precision, and travel life. Our ball screws feature leads as accurate as .0002 in./ft. and fluctuation (wobble) resolution as low as .0001 in. Predictable travel life is made possible by maintaining tight quality and process control measures.

## Inspection

What some suppliers may consider to be complex or elaborate inspection methods are routine in-house procedures at Danaher Motion. Tests for structural and metallurgical integrity include magnetic particle, dye penetrant, and eddy current inspections. Laser interferometry is used for measuring lead accuracy and fluctuation. Our fully equipped engineering laboratory performs qualification testing for mechanical performance, environmental effects, and structural integrity. Your ball screw is inspected every step of the way to ensure top quality and performance. The result, Thomson ball screws perform the way you expect them to perform — no surprises, no problems.

## Materials

The materials used to manufacture ball screws are critical to their performance. Our in-house metallurgists control and verify that the materials used are of the highest quality. They can also select and recommend materials best suited to your particular application.

## Applications Support

While manufacturing top quality ball screws is a key ingredient to customer satisfaction, the true measure of a ball screw supplier is gauged by the level of applications engineering, service, and support provided. Working with us is like having your own staff of ball screw design engineers able to address application concerns and recommend solutions. The company's sales and engineering personnel have more ball screw expertise than any other group in the industry. They are skilled at evaluating your requirements and designing assemblies that fit your needs.

## Customer Service

Danaher Motion customer service is flexible in developing delivery schedules for your production requirements. District managers are linear motion experts always available for technical support and application proposals. Conveniently located in your area, they are an important interface between you and Danaher Motion.

We have the largest and most skilled network of industrial linear motion distributors, with over 1800 locations worldwide. Each person in this network is dedicated to supplying you with the right answers to your ball screw questions.

## Non-Preloaded

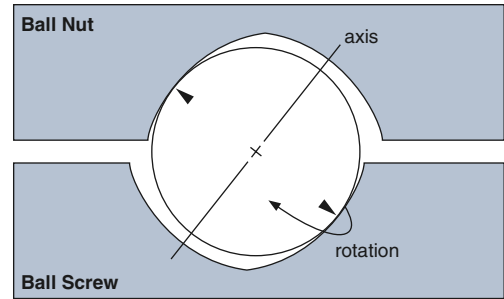

Figure 1

## Single Nut Preloaded

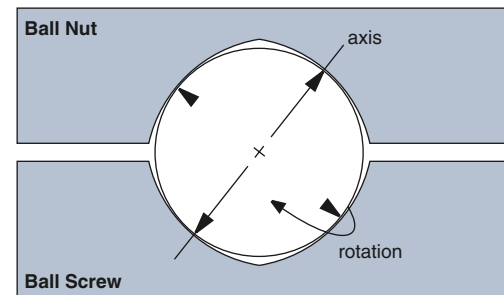

Figure 2

## Double Nut Preloaded

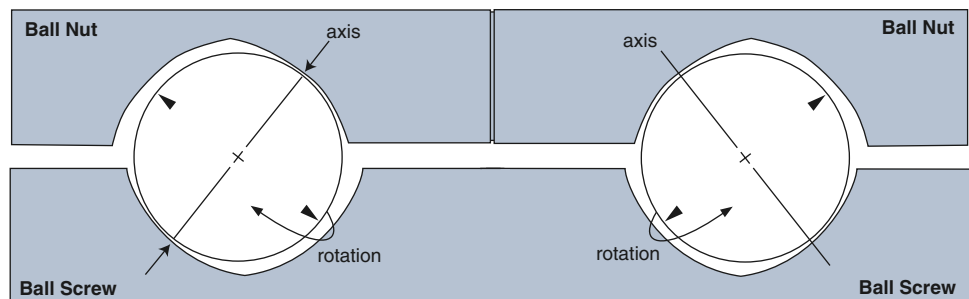

Figure 3

## Precision Inch Product Specification Summary

### Precision Screw Stock

- Lead Accuracies
  - .004 in./ft. accuracy standard
  - .002 in./ft. accuracy available (selected sizes special order)
  - .001 in./ft. accuracy available (selected sizes special order)

Ball Circle	Lead (in.)	Direction	Screw Part Number	A Root Diameter (in.)	B Maximum Lengths Available (ft.)	Weight (lb./in.)	Use With These Ball Nuts	Use with these Mounting Blocks
.187	.050 <sup>†</sup>	RH	7821634	.140	1	.006	7821632, 7821609	
	.062 <sup>†</sup>	RH	7821633	.140	1	.006	7821579, 7831631	
.312	.100	RH	7832897	.240	3	.016	7832875	
.375	.062	RH	7832894	.327	3	.027	7832874	
.375	.125	RH	5707538	.300	4	.026	5709574, 5707502	
	.125	LH	5708532	.300	4	.026	5708282, 5709576	
	.125 <sup>‡</sup>	RH	5706540	.300	4	.026	5709578, 5707643	
	.125	RH	7824974	.285	4	.026	7824973, 7831870	
.500	.200	RH	7826721	.360	6	.040	7826721, 7826763, 7823871	7828282
	.500 <sup>‡</sup>	RH	5706740	.360	4	.042	5707506, 5709582, 7826767	7828282
	.500 <sup>††</sup>	RH	5706846	.360	6	.042	5707644, 5709584	7828282
.631	.200	RH	5707540 <sup>‡</sup>	.480	6	.069	7820827 <sup>‡</sup> , 7820955, 7823584, 7832206	7824154
	.200	LH	5707541 <sup>‡</sup>	.480	6	.069	7820828 <sup>‡</sup>	7824154
	.200 <sup>‡</sup>	RH	5705378	.480	6	.069	5707645	7824154
	1.000	RH	7826712	.480	6	.069	7826713, 7827531	7824154
.750	.200	RH	7824298	.600	6	.121	7824297	7824155
	.200	RH	7826770	.625	6	.125	7826768, 7823870	7824155
	.500 <sup>‡</sup>	RH	7824361	.580	6	.131	7824358, 7826991	7824155
.875	.200	RH	5708859	.735	12	.148	5708277, 7823585	7824156
1.000	.250	RH	7820426 <sup>‡</sup>	.820	16	.183	5707508 <sup>‡</sup> , 5700348 <sup>‡</sup> , 5708278, 5704167, 7823586	7824157
	.250	LH	7820428 <sup>‡</sup>	.820	16	.183	5707535 <sup>‡</sup> , 5708284, 5704168	7824157
	.500 <sup>‡</sup>	RH	7824290	.830	16	.183	7824286	7824157
	1.000 <sup>‡</sup>	RH	7820429	.820	16	.183	5707509	7824157
1.150	.200	RH	7820430	1.005	16	.265	5701566, 5704270, 7823587	7824158
	.200	LH	7820431	1.005	16	.265	7820207, 7820206	7824158
1.171	.413	RH	7820432	.870	16	.231	5707511	7824157
1.500	.250	RH	7820595	1.320	20	.432	5709587, 5704271, 7823588	7824159
	.250	LH	7820596	1.320	20	.432	5701990	7824159
	.473	RH	7820597	1.140	20	.373	5707513, 5708345 (KW)	7824158
	.500	RH	7824253	1.140	20	.399	7824246	7824159
	1.000 <sup>‡</sup>	RH	7820598	1.140	20	.373	5708280, 5700698	7824159
	1.000 <sup>‡</sup>	LH	7825925	1.140	20	.373	5701995	7824159
2.250	1.875 <sup>‡</sup>	RH	7820599	1.188	20	.438	5707654, 5704272	7824159
	.500	RH	7820600	1.850	20	.906	5707516, 5708346 (KW), 7823589	7824160
	.500	LH	7820602	1.850	20	.906	5704000	7824160
2.500	1.000 <sup>‡</sup>	RH	7820604	1.850	20	.906	5704555	7824160
	.250	RH	7820606	2.320	20	1.288	5703243, 7823590	7824161
	.500	RH	7824262	2.100	20	1.167	7824136	7824161
3.000	.660	RH	7820607	2.480	20	1.635	5707519, 5708347 (KW), 5703045	
	1.500 <sup>‡</sup>	RH	7820609	2.480	20	1.610	5704986	
4.000	1.000	RH	5703262	3.338	20	2.869	5703258	
6.000	1.000	RH	5704762	5.220	20	6.830	5704738	

INCH

Longer lengths available on request. Contact factory.

<sup>†</sup> Stainless Steel

<sup>‡</sup> Multiple Start Thread

<sup>‡</sup> Value Priced

(KW) Keyway



©2004 Danaher Motion. Printed in the U.S.A. The specifications in this publication are believed to be accurate and reliable. However, it is the responsibility of the product user to determine the suitability of Thomson products for a specific application. While defective products will be replaced without charge if promptly returned, no liability is assumed beyond such replacement.

## Precision - Inch

- Non-Preloaded Backlash
- Preloaded Zero Backlash

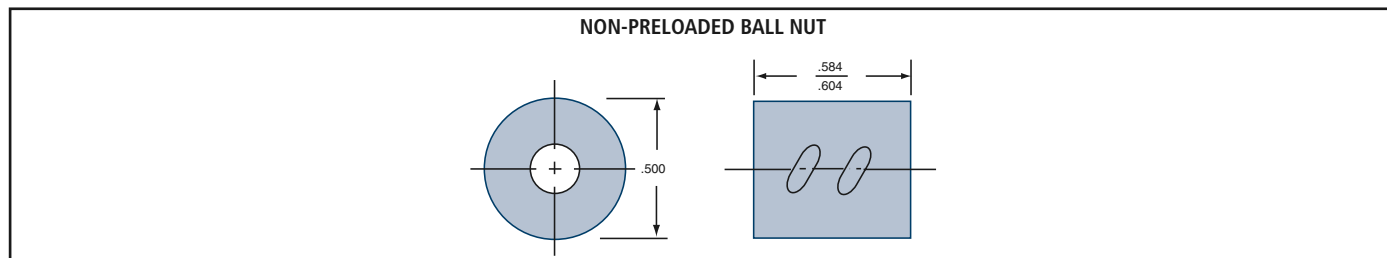

Ball Circle Diameter (size)	Lead (in.)	General Description	Ball Nut Part Number	Ball Screw Part Number	Dynamic Load (lb <sub>f</sub> ) 10 <sup>6</sup> in.	Max Static Load (lb <sub>f</sub> )	Ball Nut Weight (lb)	Flange Part Number	Wiper Kit Part Number	End Block Part Number
.187	.050	RH, SS, NP RH, Epoxy, NP	7821609 7821632	7821634 7821634	20 3	75 5	.0046 .0046	N/A N/A	N/A N/A	N/A N/A

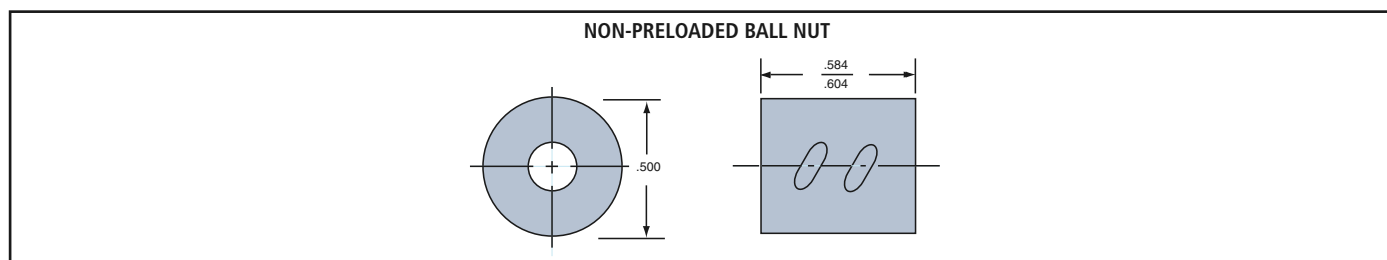

Ball Circle Diameter (size)	Lead (in.)	General Description	Ball Nut Part Number	Ball Screw Part Number	Dynamic Load (lb <sub>f</sub> ) 10 <sup>6</sup> in.	Max Static Load (lb <sub>f</sub> )	Ball Nut Weight (lb)	Flange Part Number	Wiper Kit Part Number	End Block Part Number
.187	.062	RH, SS, NP RH, Epoxy, NP	7821579 7821631	7821633 7821633	20 3	75 5	.0046 .0046	N/A N/A	N/A N/A	N/A N/A

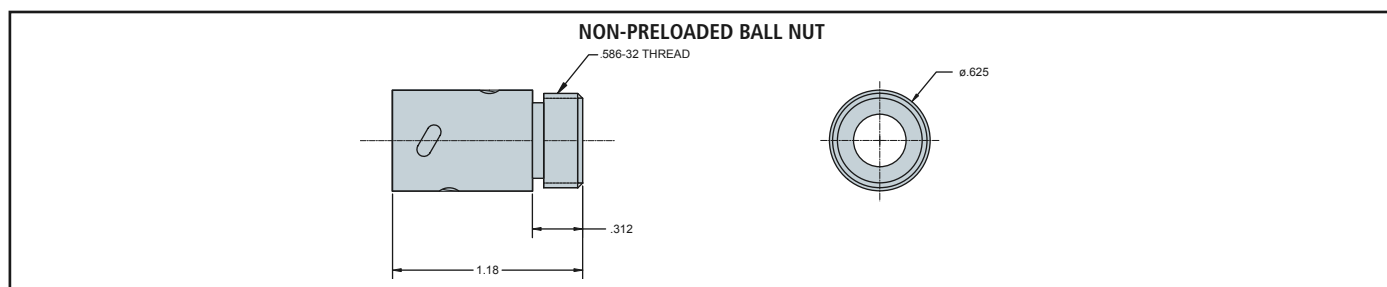

Ball Circle Diameter (size)	Lead (in.)	General Description	Ball Nut Part Number	Ball Screw Part Number	Dynamic Load (lb <sub>f</sub> ) 10 <sup>6</sup> in.	Max Static Load (lb <sub>f</sub> )	Ball Nut Weight (lb)	Flange Part Number	Wiper Kit Part Number	End Block Part Number
.312	.100	RH, NP	7832875	7832897	105	513	.126	N/A	N/A	N/A

\* Customer to provide 1 wiper retainer. See pg. 89

Precision - Inch

- Non-Preloaded Backlash
- Preloaded Zero Backlash

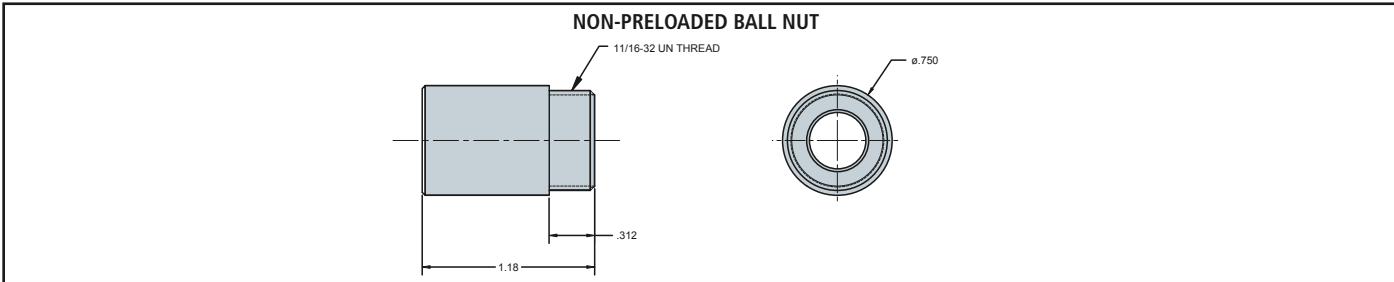

Ball Circle Diameter (size)	Lead (in.)	General Description	Ball Nut Part Number	Ball Screw Part Number	Dynamic Load (lb <sub>f</sub> ) 10 <sup>6</sup> in.	Max Static Load (lb <sub>f</sub> )	Ball Nut Weight (lb)	Flange Part Number	Wiper Kit Part Number	End Block Part Number
.375	.0625	RH, NP	7832874	7832894	159	1063	.126	N/A	N/A	N/A

INCH

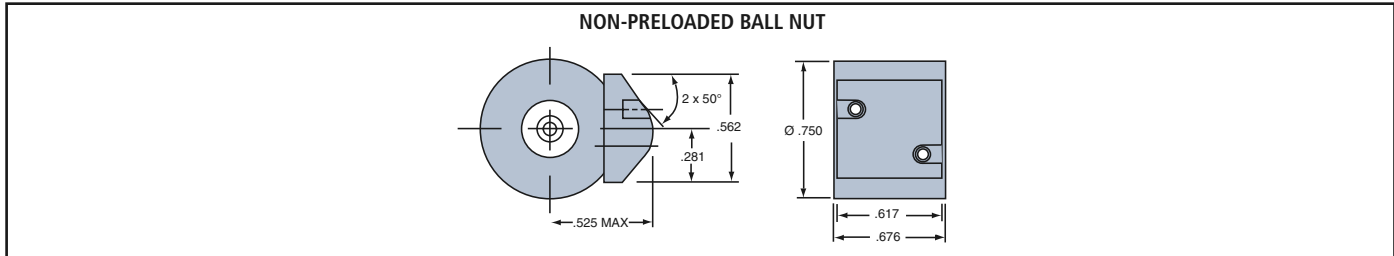

Ball Circle Diameter (size)	Lead (in.)	General Description	Ball Nut Part Number	Ball Screw Part Number	Dynamic Load (lb <sub>f</sub> ) 10 <sup>6</sup> in.	Max Static Load (lb <sub>f</sub> )	Ball Nut Weight (lb)	Flange Part Number	Wiper Kit Part Number	End Block Part Number
.375	.125	RH, NP High Capacity	7824973	7824974	170	1600	.126	N/A	N/A	N/A

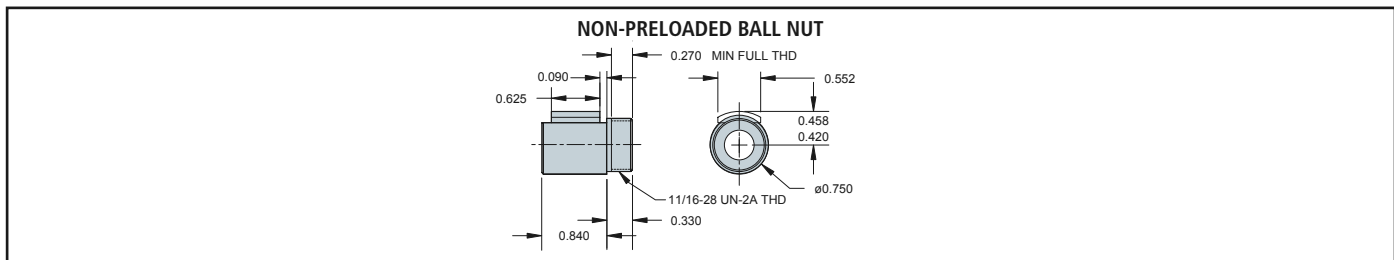

Ball Circle Diameter (size)	Lead (in.)	General Description	Ball Nut Part Number	Ball Screw Part Number	Dynamic Load (lb <sub>f</sub> ) 10 <sup>6</sup> in.	Max Static Load (lb <sub>f</sub> )	Ball Nut Weight (lb)	Flange Part Number	Wiper Kit Part Number	End Block Part Number
.375	.125	RH, NP High Capacity	7831870	7824974	170	1600	.126	N/A	N/A	N/A

\* Customer to provide 1 wiper retainer. See pg. 89

## Precision - Inch

- Non-Preloaded Backlash
- Preloaded Zero Backlash

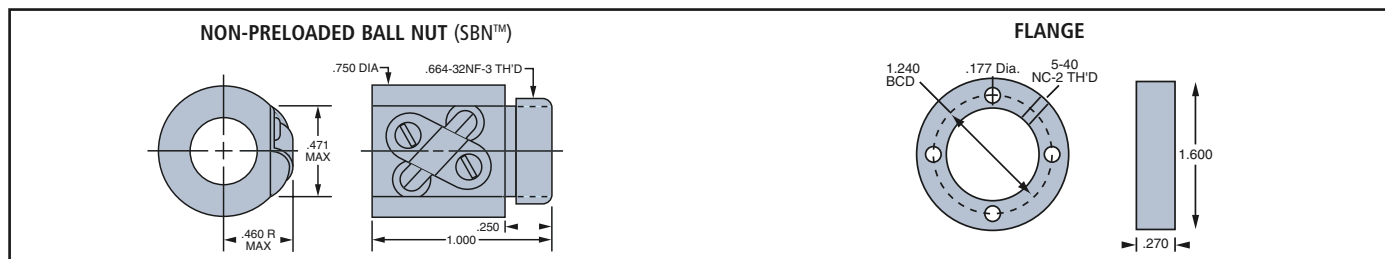

Ball Circle Diameter (size)	Lead (in.)	General Description	Ball Nut Part Number	Ball Screw Part Number	Dynamic Load (lb <sub>f</sub> ) 10 <sup>6</sup> in.	Max Static Load (lb <sub>f</sub> )	Ball Nut Weight (lb)	Flange Part Number	Wiper Kit Part Number	End Block Part Number
.375	.125	RH, C1, NP	5709574	5707538	136	1415	.126	5706751	N/A	N/A
		RH, C1, SS, NP	5709578	5706540	24	255	.126	Consult factory	N/A	N/A
		LH, C1, NP	5709576	5708532	136	1415	.126	5706751	N/A	N/A

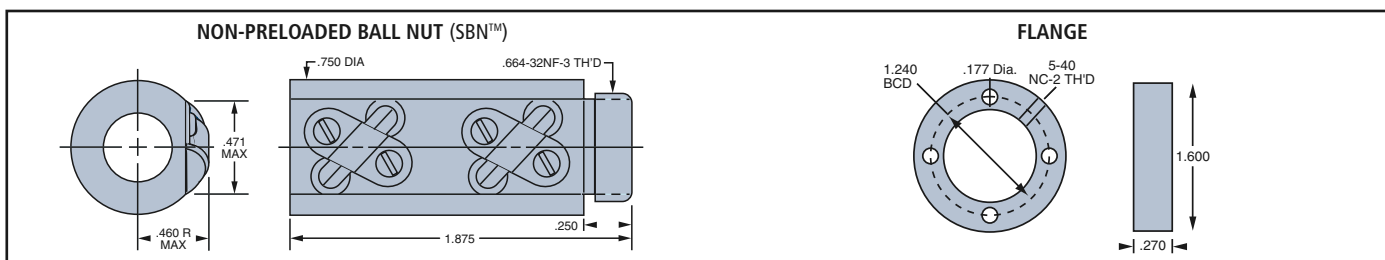

Ball Circle Diameter (size)	Lead (in.)	General Description	Ball Nut Part Number	Ball Screw Part Number	Dynamic Load (lb <sub>f</sub> ) 10 <sup>6</sup> in.	Max Static Load (lb <sub>f</sub> )	Ball Nut Weight (lb)	Flange Part Number	Wiper Kit Part Number	End Block Part Number
.375	.125	RH, C2, SS, NP	5707643	5706540	50	509	.156	Consult factory	N/A	N/A
		RH, C2, NP	5707502	5707538	272	2,830	.156	5706751	N/A	N/A
		LH, C2, NP	5708282	5708532	272	2,830	.156	5706751	N/A	N/A

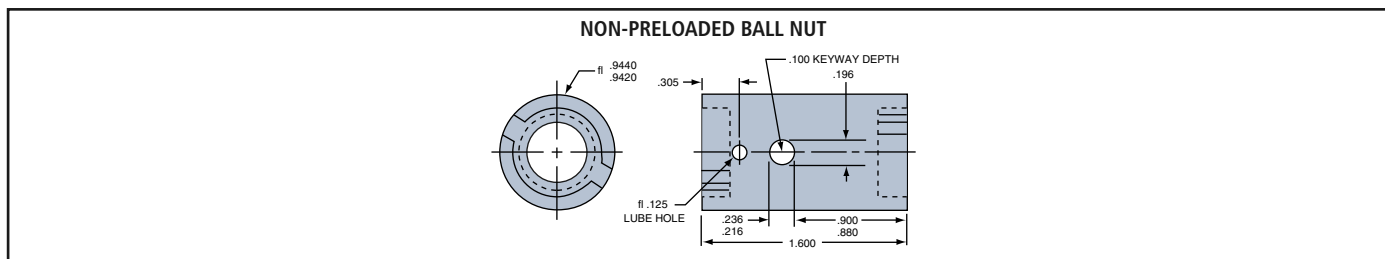

Ball Circle Diameter (size)	Lead (in.)	General Description	Ball Nut Part Number	Ball Screw Part Number	Dynamic Load (lb <sub>f</sub> ) 10 <sup>6</sup> in.	Max Static Load (lb <sub>f</sub> )	Ball Nut Weight (lb)	Flange Part Number	Wiper Kit Part Number	End Block Part Number
.500	.200	RH, KW, NP	7826763	7826721	473	2,850	.180	N/A	Integral	7828282



Precision - Inch

- Non-Preloaded Backlash
- Preloaded Zero Backlash

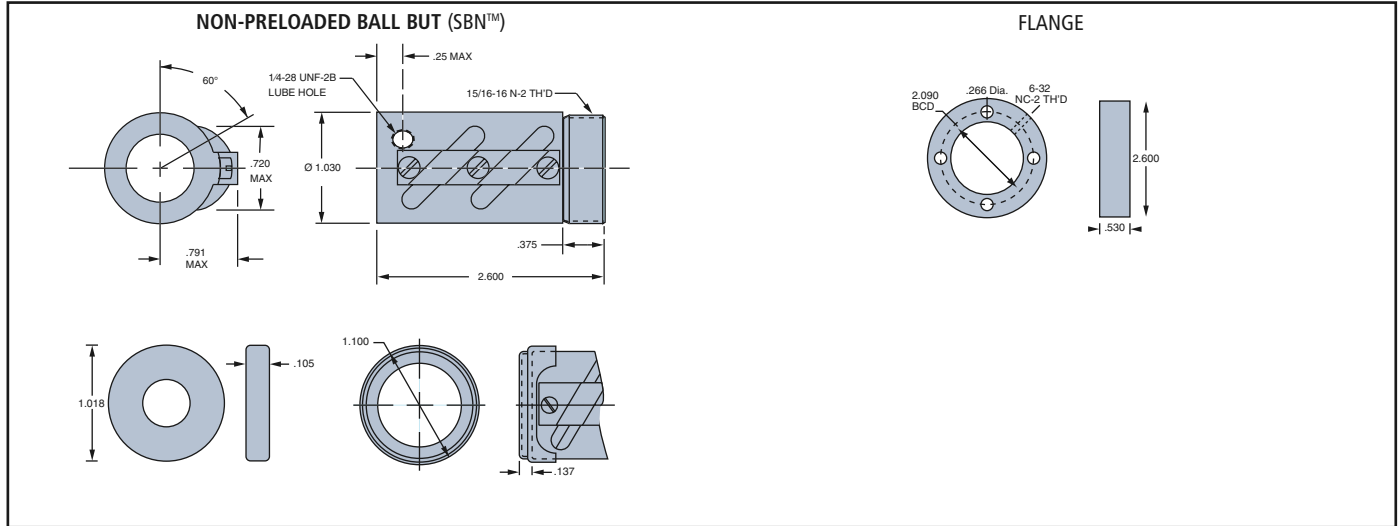

Ball Circle Diameter (size)	Lead (in.)	General Description	Ball Nut Part Number	Ball Screw Part Number	Dynamic Load (lb <sub>f</sub> ) 10° in.	Max Static Load (lb <sub>f</sub> )	Ball Nut Weight (lb)	Flange Part Number	Wiper Kit Part Number	End Block Part Number
.500	.200	RH, NP	7826720	7826721	1357	9430	.550	5707570	7826759*	7828282

\* Customer to provide 1 wiper retainer. See pg. 85

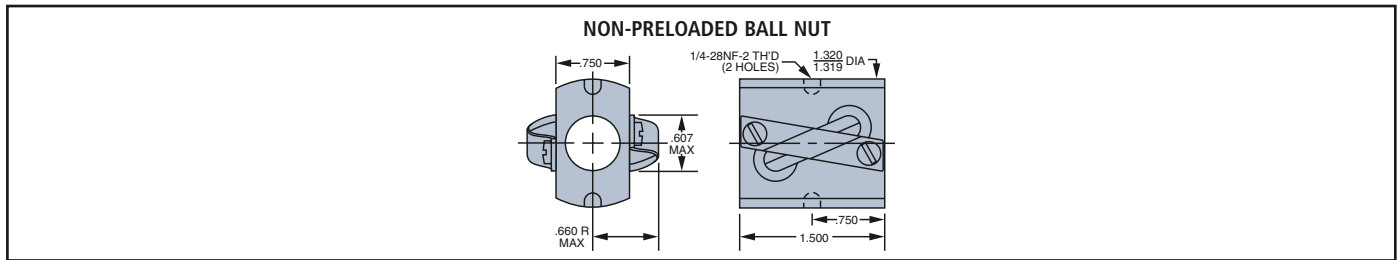

Ball Circle Diameter (size)	Lead (in.)	General Description	Ball Nut Part Number	Ball Screw Part Number	Dynamic Load (lb <sub>f</sub> ) 10° in.	Max Static Load (lb <sub>f</sub> )	Ball Nut Weight (lb)	Flange Part Number	Wiper Kit Part Number	End Block Part Number
.500	.500	RH, NP RH, SS, NP	5707506 5707644	5706740 5706846	786 141	4131 744	.267 .267	N/A N/A	N/A N/A	7828282 7828282

INCH

## Precision - Inch

- Non-Preloaded Backlash
- Preloaded Zero Backlash



Ball Circle Diameter (size)	Lead (in.)	General Description	Ball Nut Part Number	Ball Screw Part Number	Dynamic Load (lb <sub>f</sub> ) 10 <sup>6</sup> in.	Max Static Load (lb <sub>f</sub> )	Ball Nut Weight (lb)	Flange Part Number	Wiper Kit Part Number	End Block Part Number
.500	.500	RH, NP	5709582	5706740	786	4131	.273	5707570	N/A	7828282
		RH, SS, NP	5709584	5706846	141	744	.273	Consult factory	N/A	7828282

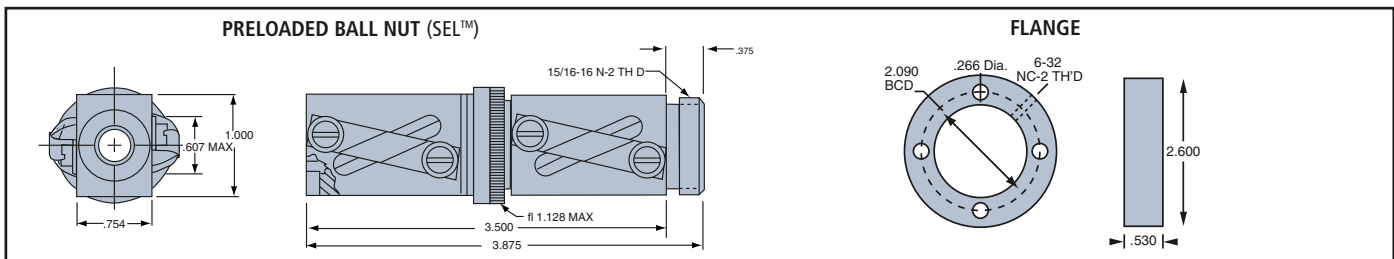

Ball Circle Diameter (size)	Lead (in.)	General Description	Ball Nut Part Number	Ball Screw Part Number	Dynamic Load (lb <sub>f</sub> ) 10 <sup>6</sup> in.	Max Static Load (lb <sub>f</sub> )	Ball Nut Weight (lb)	Flange Part Number	Wiper Kit Part Number	End Block Part Number
.500	.500	RH, Preload	7826767	5706740	786	4,131	.650	5707570	N/A	7828282

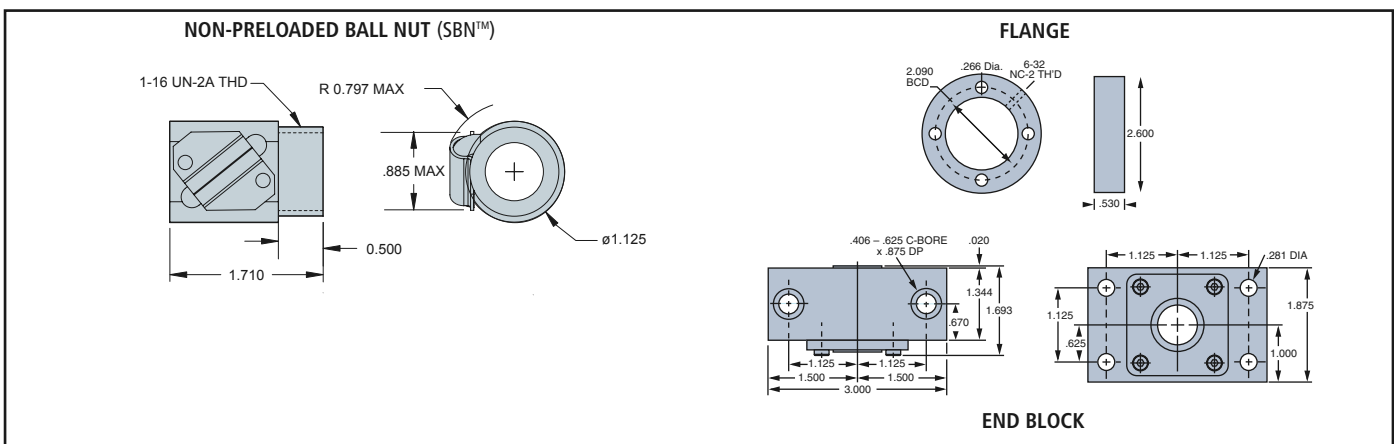

Ball Circle Diameter (size)	Lead (in.)	General Description	Ball Nut Part Number	Ball Screw Part Number	Dynamic Load (lb <sub>f</sub> ) 10 <sup>6</sup> in.	Max Static Load (lb <sub>f</sub> )	Ball Nut Weight (lb)	Flange Part Number	Wiper Kit Part Number	End Block Part Number
.631	.200	RH, NP	7832206	5707540	778	6384	.270	7832920	Establish "M" Type Nut 2 Wipers no Retainers	7824154

Precision - Inch

- Non-Preloaded Backlash
- Preloaded Zero Backlash

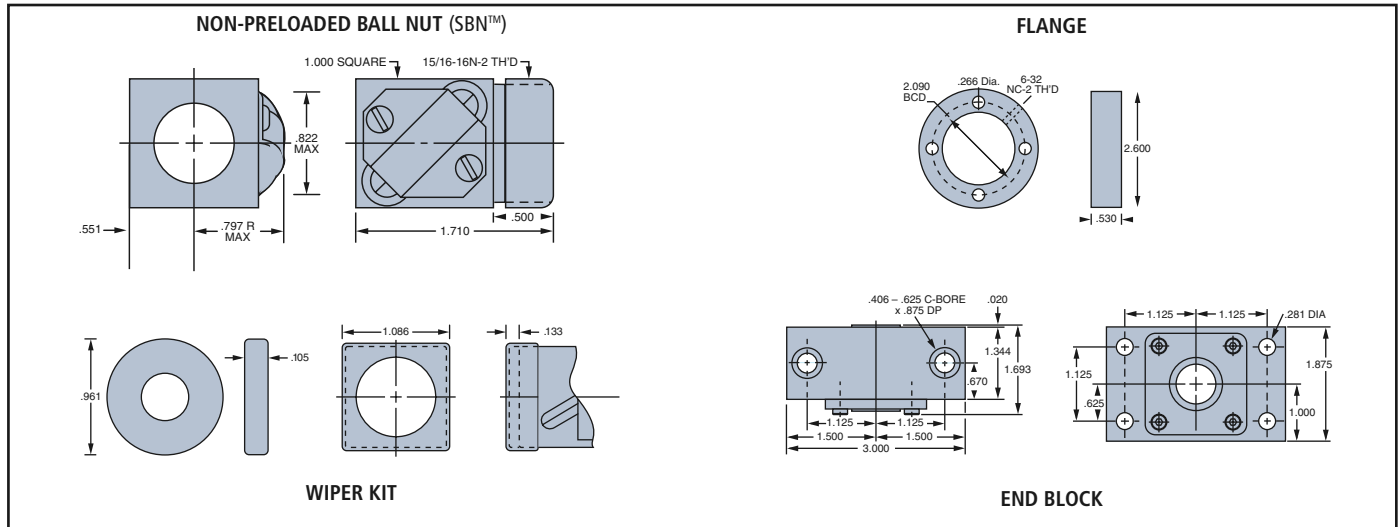

Ball Circle Diameter (size)	Lead (in.)	General Description	Ball Nut Part Number	Ball Screw Part Number	Dynamic Load (lb <sub>f</sub> ) 10 <sup>6</sup> in.	Max Static Load (lb <sub>f</sub> )	Ball Nut Weight (lb)	Flange Part Number	Wiper Kit Part Number	End Block Part Number
.631	.200	RH, NP*	7820827	5707540	778	6,384	.270	5707570	5702647	7824154
		LH, NP*	7820828	5707541	778	6,384	.270	5707570	5702647	7824154
		RH, SS, NP	5707645	5705378	140	1,149	.270	Consult factory	5702647	7824154

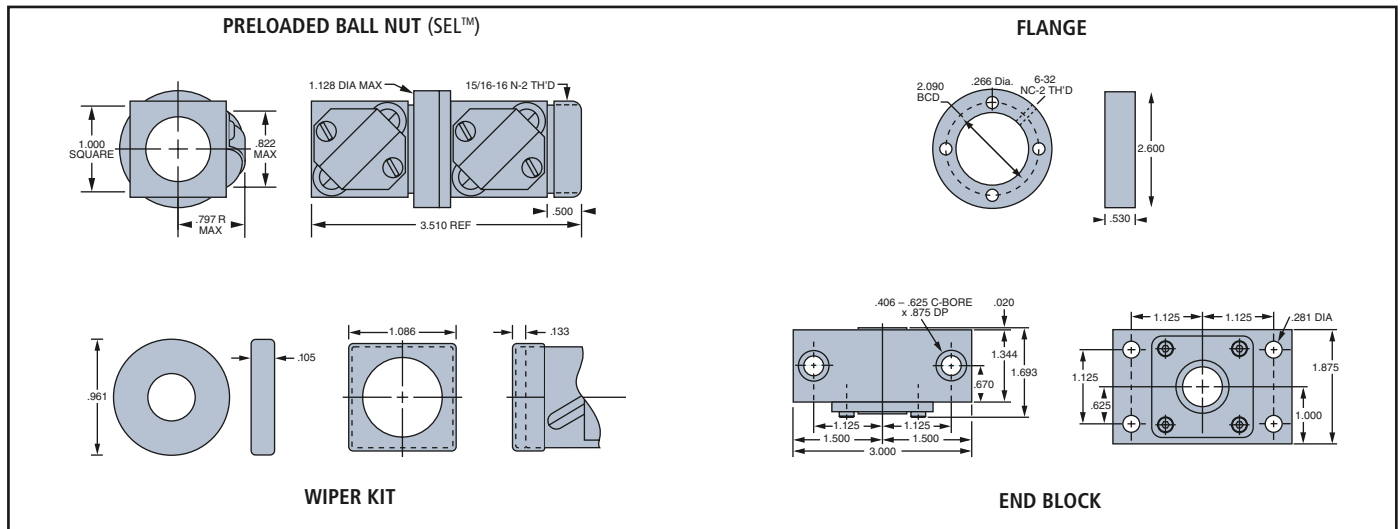

Ball Circle Diameter (size)	Lead (in.)	General Description	Ball Nut Part Number	Ball Screw Part Number	Dynamic Load (lb <sub>f</sub> ) 10 <sup>6</sup> in.	Max Static Load (lb <sub>f</sub> )	Ball Nut Weight (lb)	Flange Part Number	Wiper Kit Part Number	End Block Part Number
.631	.200	RH, Preload*	7820955	5707540	778	6,384	.650	5707570	5702647*	7824154
		LH, Preload	7820956	5707541	778	6,384	.650	5707570	5702647*	7824154

\* Customer to provide 1 wiper retainer. See pg. 89

## Precision - Inch

- Non-Preloaded Backlash
- Preloaded Zero Backlash

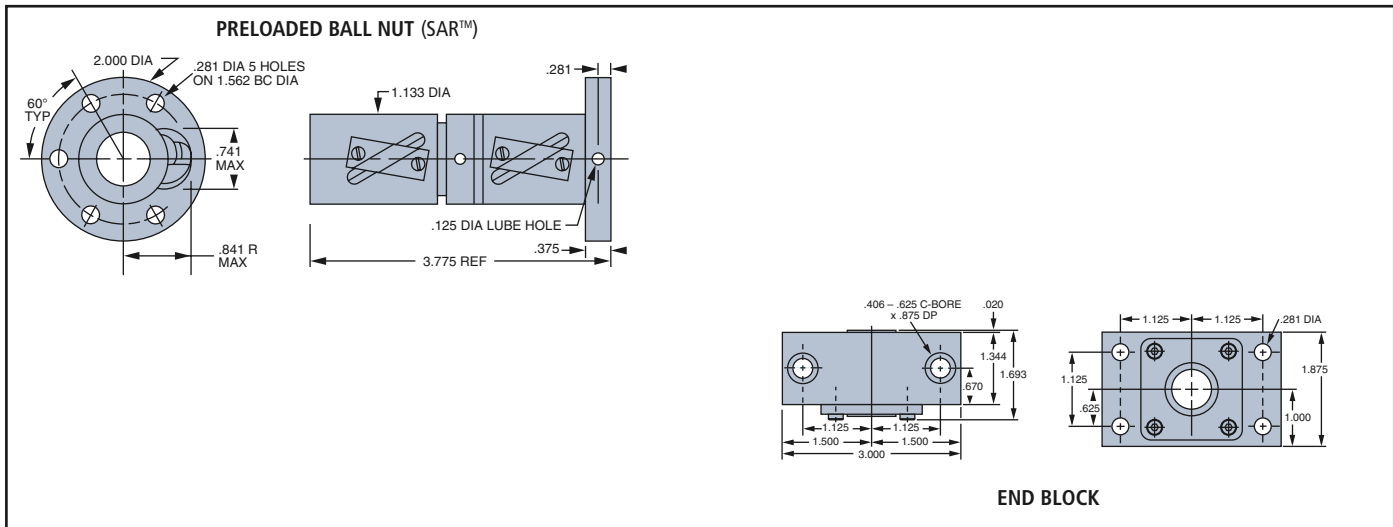

Ball Circle Diameter (size)	Lead (in.)	General Description	Ball Nut Part Number	Ball Screw Part Number	Dynamic Load (lb <sub>f</sub> ) 10 <sup>6</sup> in.	Max Static Load (lb <sub>f</sub> )	Ball Nut Weight (lb)	Flange Part Number	Wiper Kit Part Number	End Block Part Number
.631	.200	RH, Preload	7823584	5707540	778	6,384	1.000	Integral	Integral	7824154

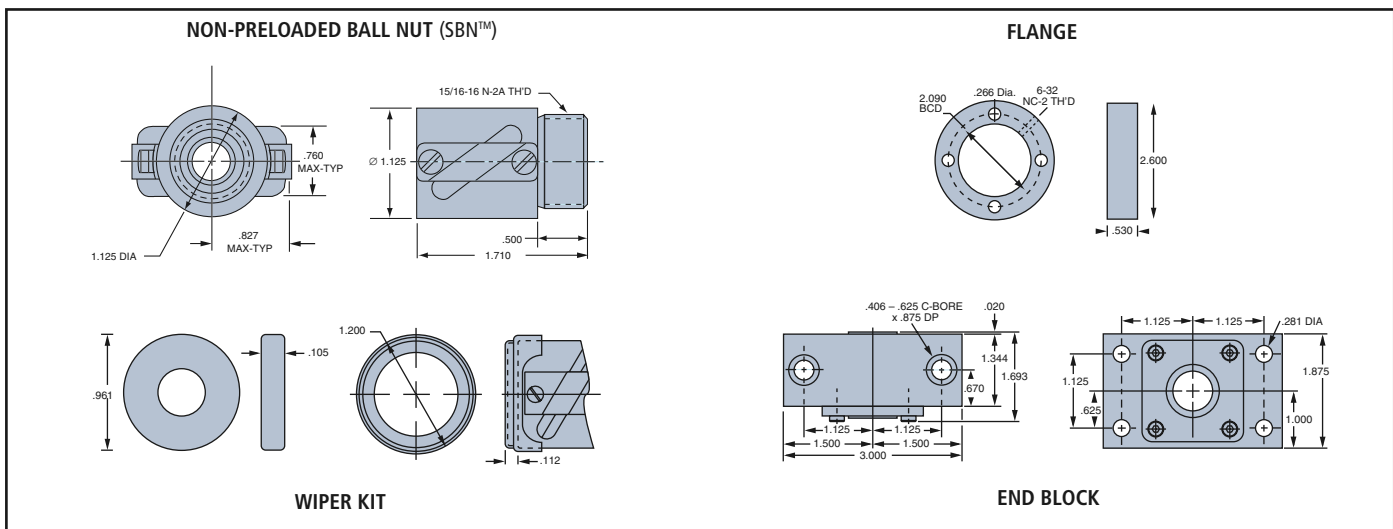

Ball Circle Diameter (size)	Lead (in.)	General Description	Ball Nut Part Number	Ball Screw Part Number	Dynamic Load (lb <sub>f</sub> ) 10 <sup>6</sup> in.	Max Static Load (lb <sub>f</sub> )	Ball Nut Weight (lb)	Flange Part Number	Wiper Kit Part Number	End Block Part Number
.631	1.000	RH, NP	7826713	7826712	578	2,425	.280	5707570	7827527*	7824154

\* Customer to provide 1 wiper retainer. See pg. 89

### General Description Legend

C1	One Circuit	NP	Non-preloaded Ball Nut	Rnd	Round
C2	Two Circuits	OAL	Overall Length	Sq.	Square
KW	Keyway	Preload	Preloaded Ball Nut	SS	Stainless Steel
LH	Left Hand	RH	Right Hand	v	Valued Priced

Precision - Inch

- Non-Preloaded Backlash
- Preloaded Zero Backlash

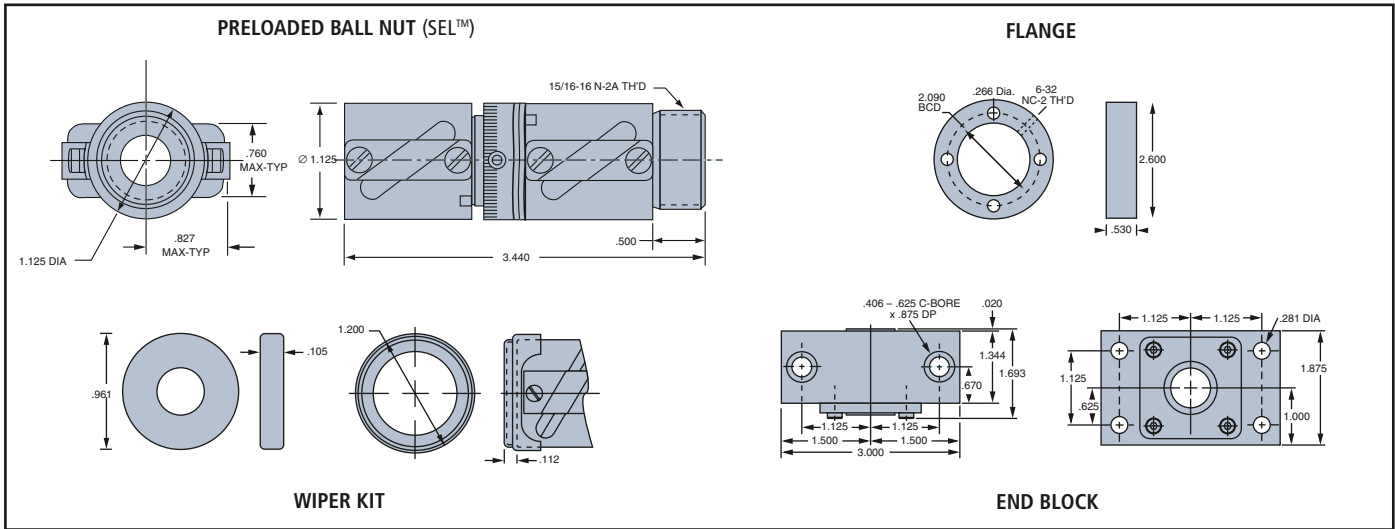

Ball Circle Diameter (size)	Lead (in.)	General Description	Ball Nut Part Number	Ball Screw Part Number	Dynamic Load (lb <sub>f</sub> ) 10 <sup>6</sup> in.	Max Static Load (lb <sub>f</sub> )	Ball Nut Weight (lb)	Flange Part Number	Wiper Kit Part Number	End Block Part Number
.631	1.000	RH, Preload	7827531	7826712	578	2,425	.670	5707570	7827527*	7824154

\* Customer to provide 1 wiper retainer. See pg. 89

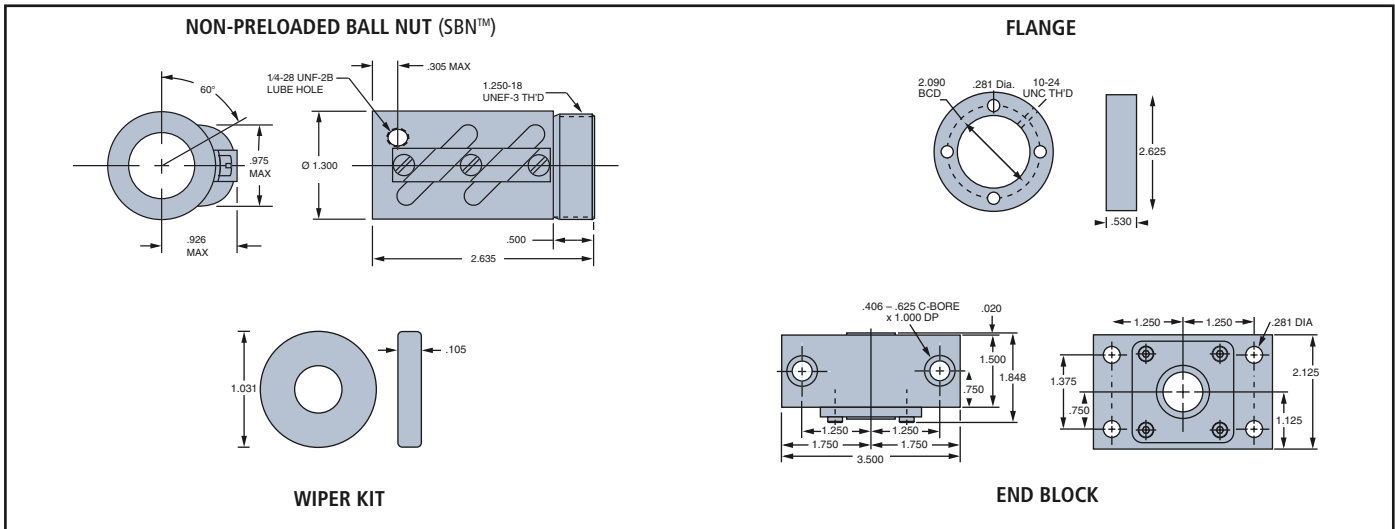

Ball Circle Diameter (size)	Lead (in.)	General Description	Ball Nut Part Number	Ball Screw Part Number	Dynamic Load (lb <sub>f</sub> ) 10 <sup>6</sup> in.	Max Static Load (lb <sub>f</sub> )	Ball Nut Weight (lb)	Flange Part Number	Wiper Kit Part Number	End Block Part Number
.750	.200	RH, NP	7824297	7824298	2,082	11,750	.679	7823336	7824337	7824155

INCH

## Precision - Inch

- Non-Preloaded Backlash
- Preloaded Zero Backlash

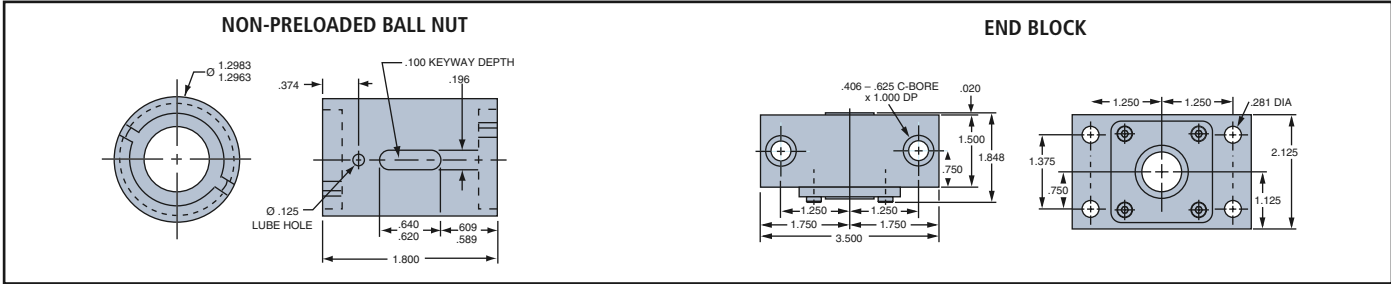

Ball Circle Diameter (size)	Lead (in.)	General Description	Ball Nut Part Number	Ball Screw Part Number	Dynamic Load (lb <sub>r</sub> ) 10 <sup>6</sup> in.	Max Static Load (lb <sub>r</sub> )	Ball Nut Weight (lb)	Flange Part Number	Wiper Kit Part Number	End Block Part Number
.750	.200	RH, KW, NP	7826768	7826770	815	6,035	.370	N/A	Integral	7824155

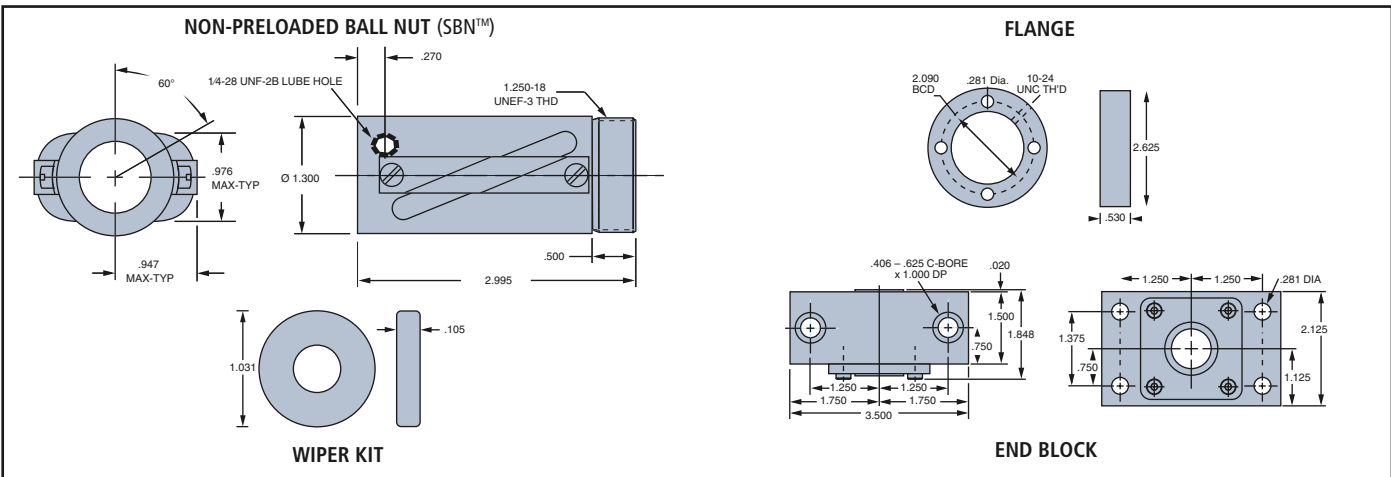

Ball Circle Diameter (size)	Lead (in.)	General Description	Ball Nut Part Number	Ball Screw Part Number	Dynamic Load (lb <sub>r</sub> ) 10 <sup>6</sup> in.	Max Static Load (lb <sub>r</sub> )	Ball Nut Weight (lb)	Flange Part Number	Wiper Kit Part Number	End Block Part Number
.750	.500	RH, NP	7824358	7824361	3,263	13,260	.799	7823336	7824337	7824155

Precision - Inch

- Non-Preloaded Backlash
- Preloaded Zero Backlash

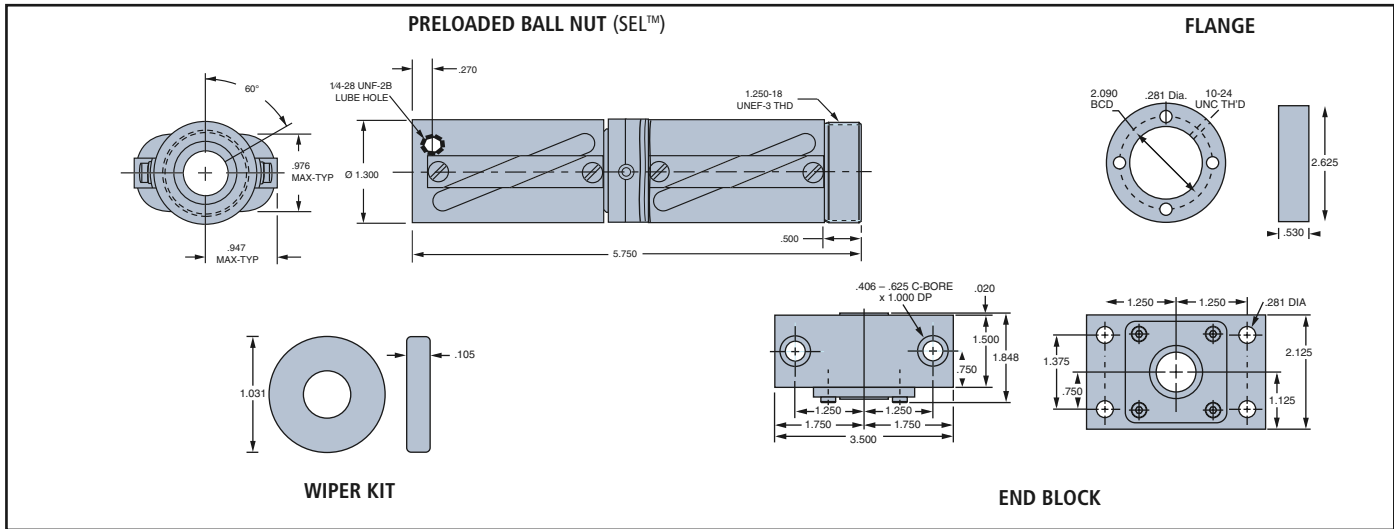

Ball Circle Diameter (size)	Lead (in.)	General Description	Ball Nut Part Number	Ball Screw Part Number	Dynamic Load (lb <sub>f</sub> ) 10° in.	Max Static Load (lb <sub>f</sub> )	Ball Nut Weight (lb)	Flange Part Number	Wiper Kit Part Number	End Block Part Number
.750	.500	RH, Preload	7826991	7824361	3,263	13,260	2.39	7823336	7824337	7824155

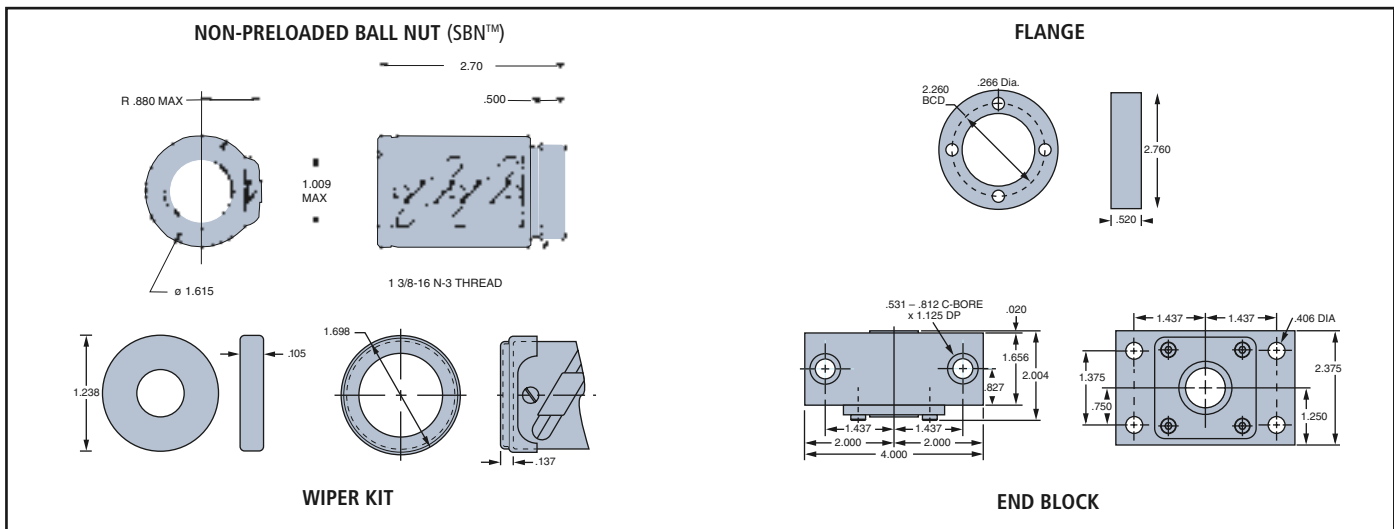

Ball Circle Diameter (size)	Lead (in.)	General Description	Ball Nut Part Number	Ball Screw Part Number	Dynamic Load (lb <sub>f</sub> ) 10° in.	Max Static Load (lb <sub>f</sub> )	Ball Nut Weight (lb)	Flange Part Number	Wiper Kit Part Number	End Block Part Number
.875	.200	RH, NP	5708277	5708859	1,942	18,063	.687	5708281	7831512	7824156

\* Customer to provide 1 wiper retainer. See pg. 89

## Precision - Inch

- Non-Preloaded Backlash
- Preloaded Zero Backlash

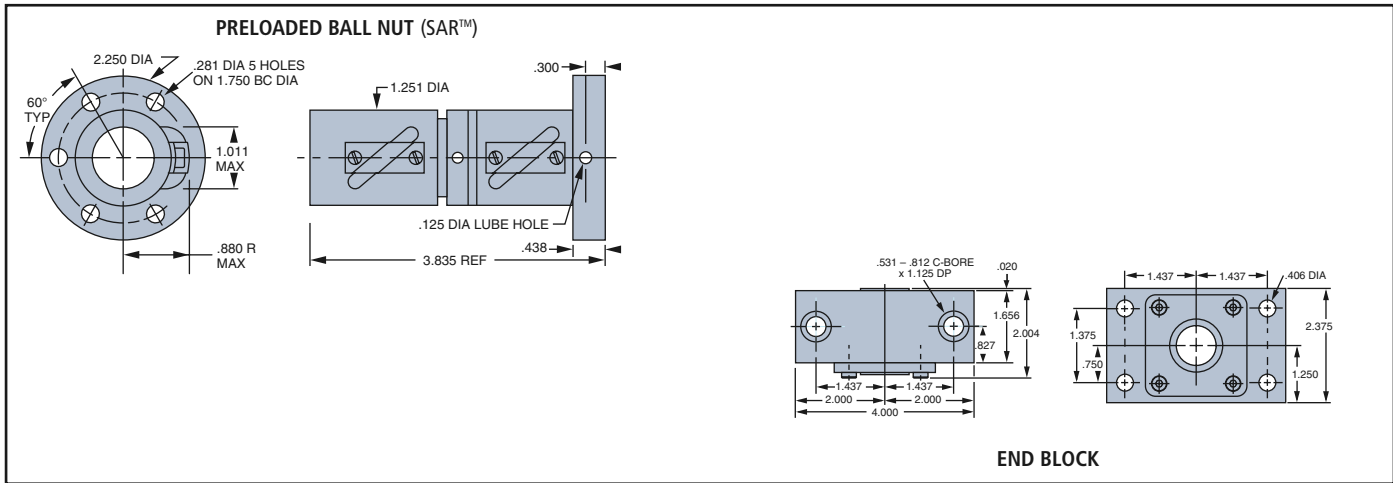

Ball Circle Diameter (size)	Lead (in.)	General Description	Ball Nut Part Number	Ball Screw Part Number	Dynamic Load (lb <sub>f</sub> ) 10° in.	Max Static Load (lb <sub>f</sub> )	Ball Nut Weight (lb)	Flange Part Number	Wiper Kit Part Number	End Block Part Number
.875	.200	RH, Preload	7823585	5708859	971	9,482	1.810	Integral	Integral	7824156

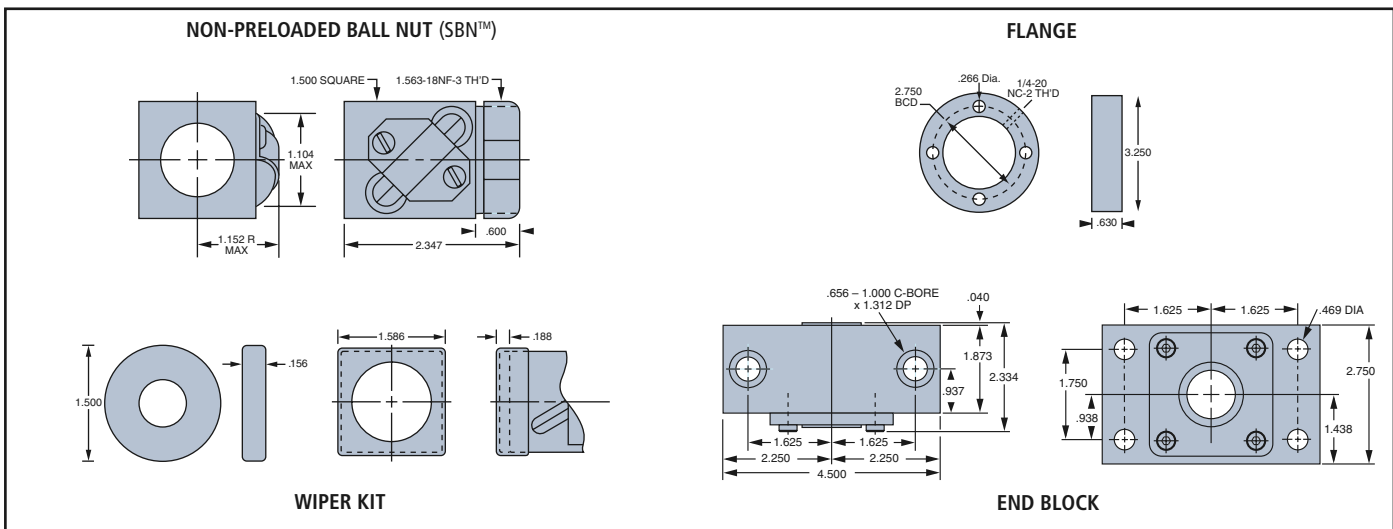

Ball Circle Diameter (size)	Lead (in.)	General Description	Ball Nut Part Number	Ball Screw Part Number	Dynamic Load (lb <sub>f</sub> ) 10° in.	Max Static Load (lb <sub>f</sub> )	Ball Nut Weight (lb)	Flange Part Number	Wiper Kit Part Number	End Block Part Number
1.000	.250	RH, Sq., NP*	5707508	7820426	1,612	13,913	.812	5707571	5702649*	7824157
		LH, Sq., NP*	5707535	7820428	1,612	13,913	.812	5707571	5702649*	7824157

\* Customer to provide 1 wiper retainer. See pg. 89

### General Description Legend

C1	One Circuit	NP	Non-preloaded Ball Nut	Rnd	Round
C2	Two Circuits	OAL	Overall Length	Sq.	Square
KW	Keyway	Preload	Preloaded Ball Nut	SS	Stainless Steel
LH	Left Hand	RH	Right Hand	v	Valued Priced



Precision - Inch

- Non-Preloaded Backlash
- Preloaded Zero Backlash

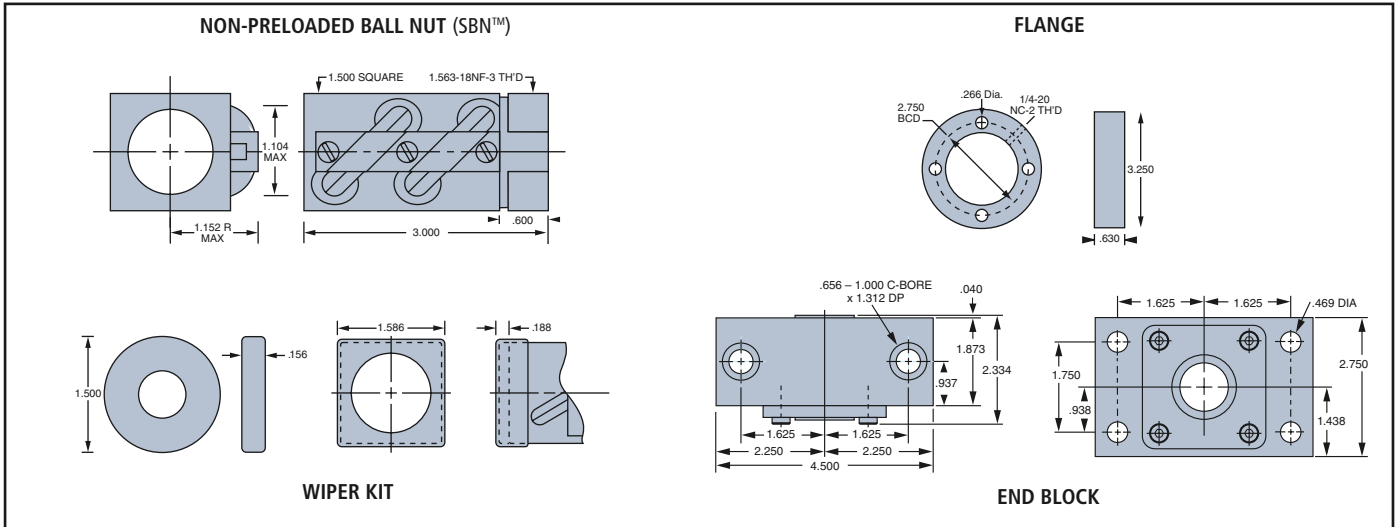

INCH

Ball Circle Diameter (size)	Lead (in.)	General Description	Ball Nut Part Number	Ball Screw Part Number	Dynamic Load (lb <sub>f</sub> ) 10° in.	Max Static Load (lb <sub>f</sub> )	Ball Nut Weight (lb)	Flange Part Number	Wiper Kit Part Number	End Block Part Number
1.000	.250	RH, Sq., NP*	5700348	7820426	3,224	27,826	1.250	5707571	5702649*	7824157

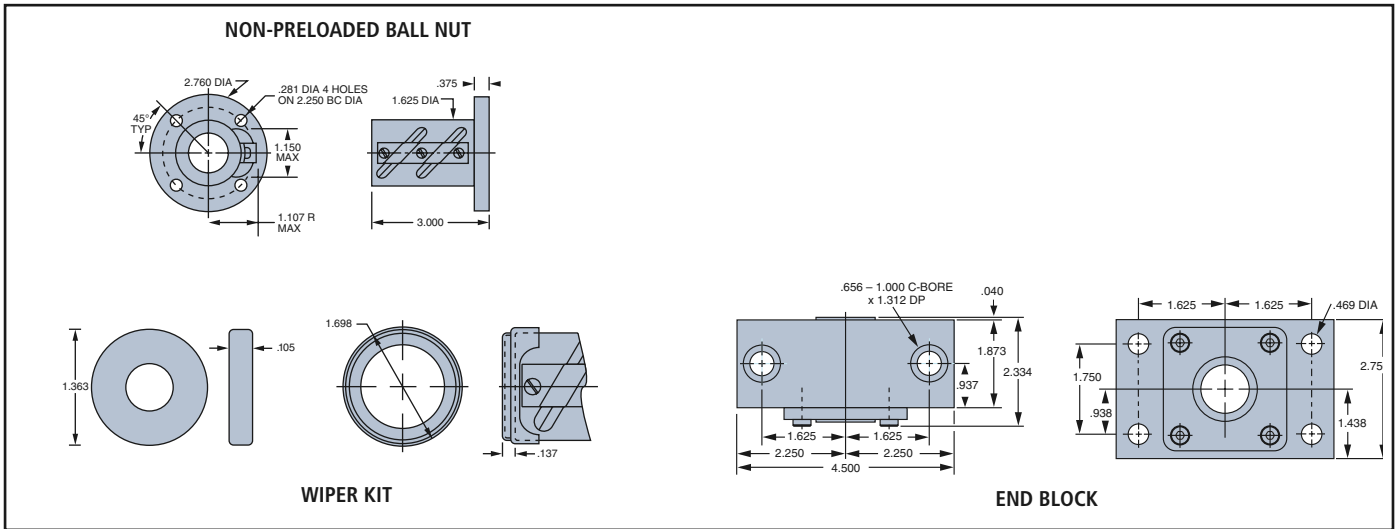

Ball Circle Diameter (size)	Lead (in.)	General Description	Ball Nut Part Number	Ball Screw Part Number	Dynamic Load (lb <sub>f</sub> ) 10° in.	Max Static Load (lb <sub>f</sub> )	Ball Nut Weight (lb)	Flange Part Number	Wiper Kit Part Number	End Block Part Number
1.000	.250	RH, Rnd, NP	5708278	7820426	3,224	27,826	1.500	Integral	5702651*	7824157
		LH, Rnd, NP	5708284	7820428	3,224	27,826	1.500	Integral	5702651*	7824157

\* Customer to provide 1 wiper retainer. See pg. 89

## Precision - Inch

- Non-Preloaded Backlash
- Preloaded Zero Backlash

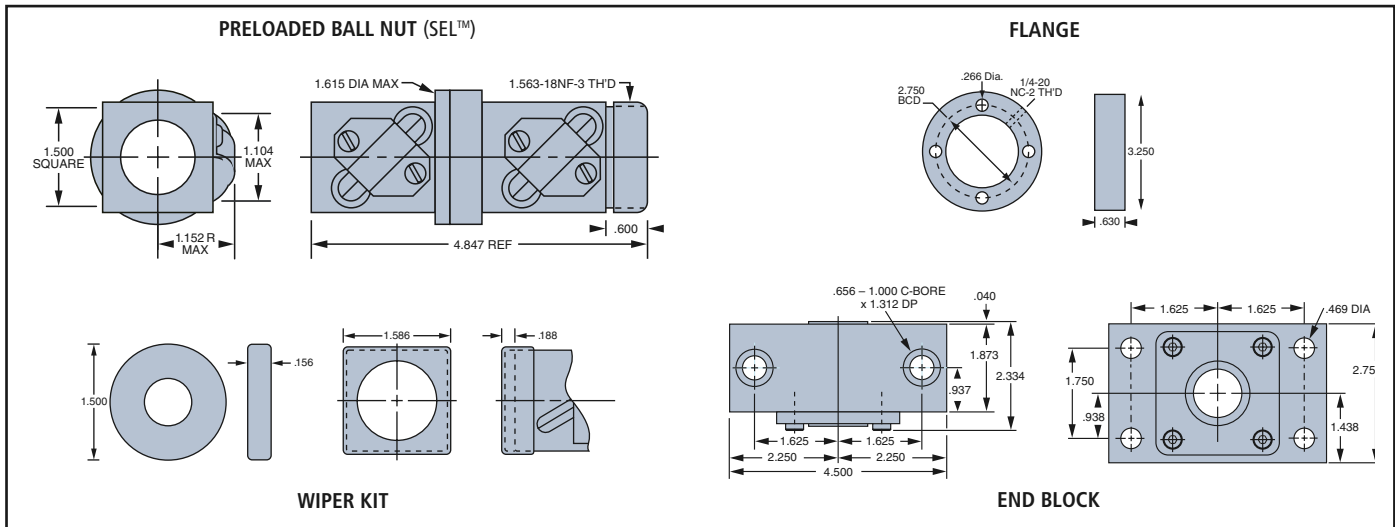

Ball Circle Diameter (size)	Lead (in.)	General Description	Ball Nut Part Number	Ball Screw Part Number	Dynamic Load (lb <sub>f</sub> ) 10 <sup>6</sup> in.	Max Static Load (lb <sub>f</sub> )	Ball Nut Weight (lb)	Flange Part Number	Wiper Kit Part Number	End Block Part Number
1.000	.250	RH, Sq., Preload <sup>*</sup> LH, Sq., Preload <sup>*</sup>	5704167 5704168	7820426 7820428	1612 1612	13,913 13,913	1.900 1.900	5707571 5707571	5702649* 5702649*	7824157 7824157

\* Customer to provide wiper retainer. See pg 89.

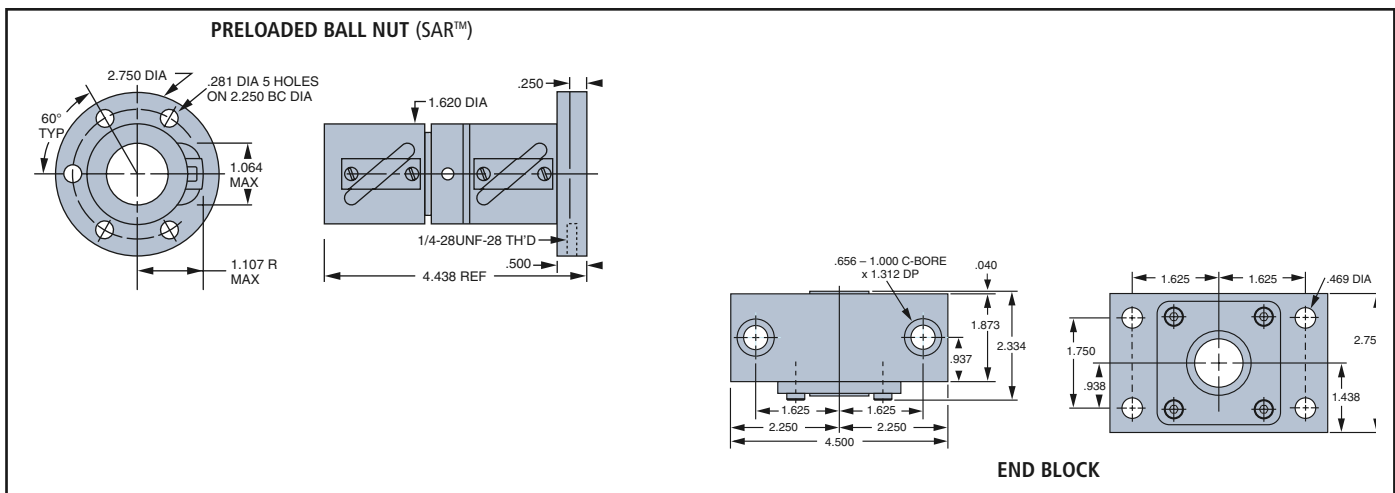

Ball Circle Diameter (size)	Lead (in.)	General Description	Ball Nut Part Number	Ball Screw Part Number	Dynamic Load (lb <sub>f</sub> ) 10 <sup>6</sup> in.	Max Static Load (lb <sub>f</sub> )	Ball Nut Weight (lb)	Flange Part Number	Wiper Kit Part Number	End Block Part Number
1.000	.250	RH, Preload	7823586	7820426	1,612	13,913	2.00	Integral	Integral	7824157

### General Description Legend

C1	One Circuit	NP	Non-preloaded Ball Nut	Rnd	Round
C2	Two Circuits	OAL	Overall Length	Sq.	Square
KW	Keyway	Preload	Preloaded Ball Nut	SS	Stainless Steel
LH	Left Hand	RH	Right Hand	v	Valued Priced

Precision - Inch

- Non-Preloaded Backlash
- Preloaded Zero Backlash

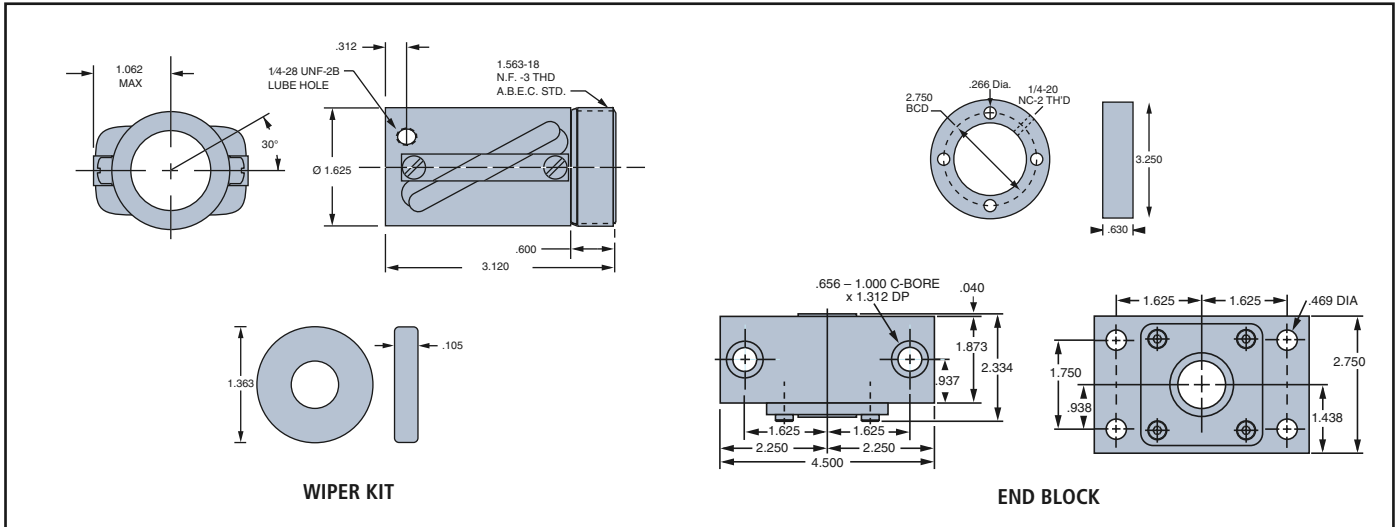

INCH

Ball Circle Diameter (size)	Lead (in.)	General Description	Ball Nut Part Number	Ball Screw Part Number	Dynamic Load (lb <sub>f</sub> ) 10 <sup>6</sup> in.	Max Static Load (lb <sub>f</sub> )	Ball Nut Weight (lb)	Flange Part Number	Wiper Kit Part Number	End Block Part Number
1.000	.500	RH, NP	7824286	7824290	3,890	18,400	1.200	5707571	7824292	7824157

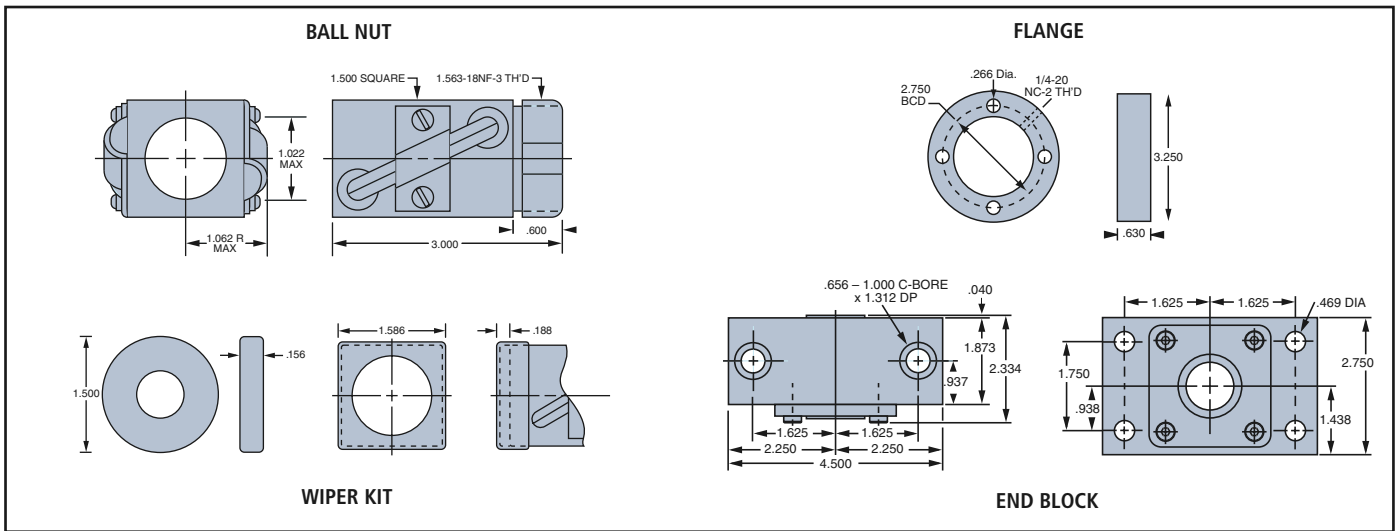

Ball Circle Diameter (size)	Lead (in.)	General Description	Ball Nut Part Number	Ball Screw Part Number	Dynamic Load (lb <sub>f</sub> ) 10 <sup>6</sup> in.	Max Static Load (lb <sub>f</sub> )	Ball Nut Weight (lb)	Flange Part Number	Wiper Kit Part Number	End Block Part Number
1.000	1.000	RH, Sq., NP	5707509	7820429	2,142	11,925	1.120	5707571	5702650*	7824157
		RH, Sq., Preload**	7829720	7820429	2,142	11,925	2.30	5707571	5702650*	7824157

\* Customer to provide 1 wiper retainer. See pg. 89  
 \*\* Not shown, SEL™ Style 6.000 overall length

## Precision - Inch

- Non-Preloaded Backlash
- Preloaded Zero Backlash

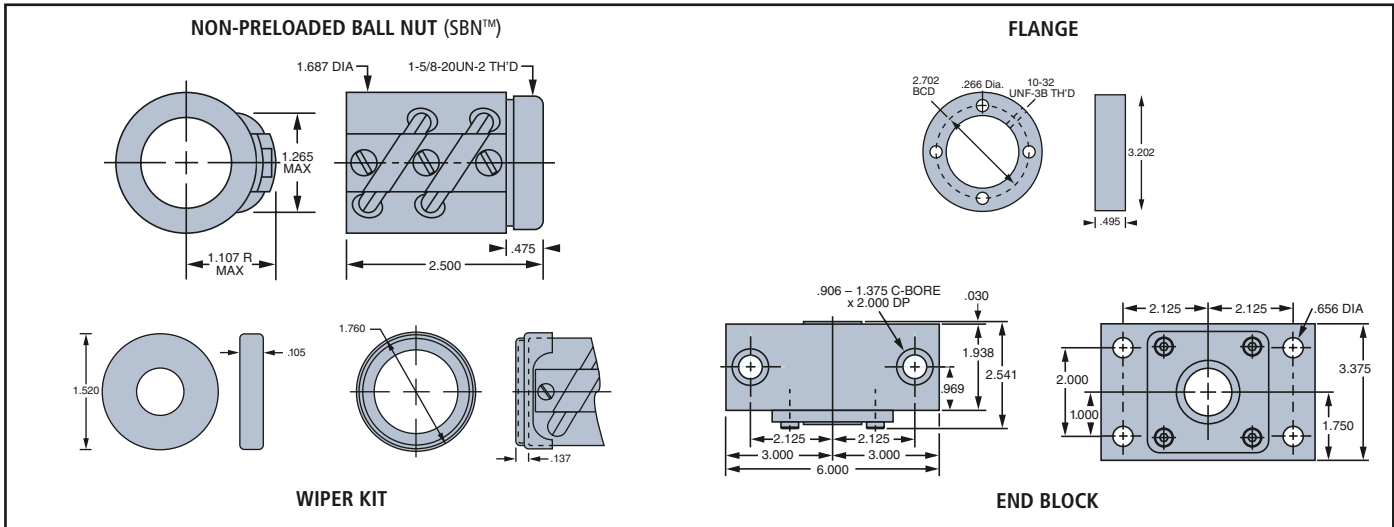

Ball Circle Diameter (size)	Lead (in.)	General Description	Ball Nut Part Number	Ball Screw Part Number	Dynamic Load (lb <sub>f</sub> ) 10° in.	Max Static Load (lb <sub>f</sub> )	Ball Nut Weight (lb)	Flange Part Number	Wiper Kit Part Number	End Block Part Number
1.150	.200	RH, NP	5701566	7820430	2,370	26,180	.875	5708283	5702652*	7824158
		LH, NP	7820207	7820431	2,370	26,180	.875	5708283	5702652*	7824158

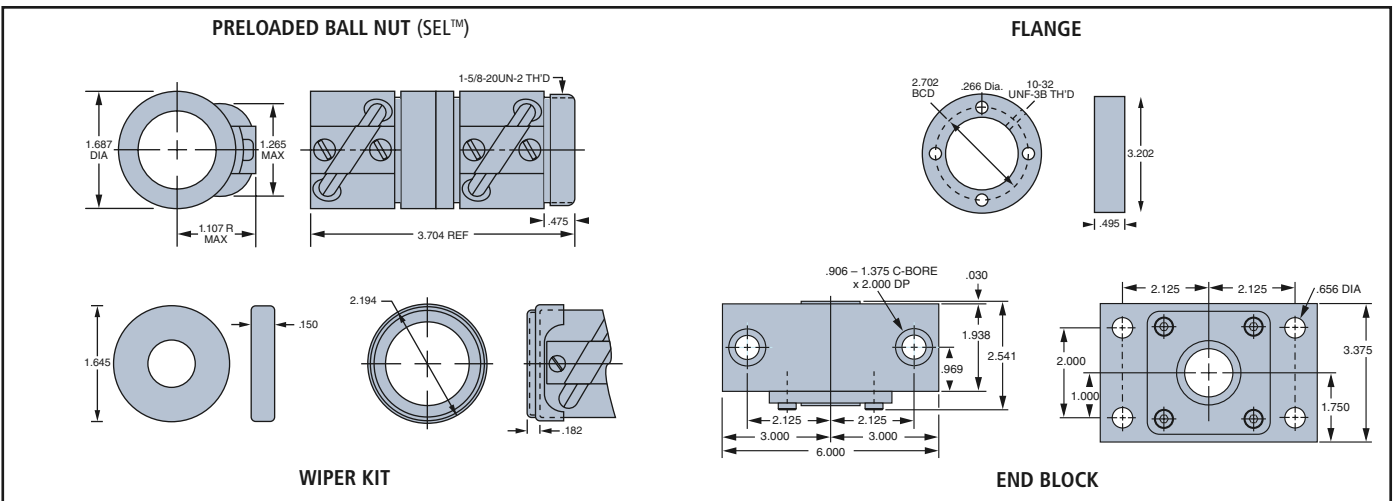

\* Customer to provide wiper retainer. See pg. 89

Ball Circle Diameter (size)	Lead (in.)	General Description	Ball Nut Part Number	Ball Screw Part Number	Dynamic Load (lb <sub>f</sub> ) 10° in.	Max Static Load (lb <sub>f</sub> )	Ball Nut Weight (lb)	Flange Part Number	Wiper Kit Part Number	End Block Part Number
1.150	.200	RH, Preload <sup>v</sup>	5704270	7820430	1,185	13,090	1.34	5708283	5702652*	7824158
		LH, Preload <sup>v</sup>	7820206	7820431	1,185	13,090	1.34	5708283	5702652*	7824158

### General Description Legend

C1	One Circuit	NP	Non-preloaded Ball Nut	Rnd	Round
C2	Two Circuits	OAL	Overall Length	Sq.	Square
KW	Keyway	Preload	Preloaded Ball Nut	SS	Stainless Steel
LH	Left Hand	RH	Right Hand	v	Valued Priced

Precision - Inch

- Non-Preloaded Backlash
- Preloaded Zero Backlash

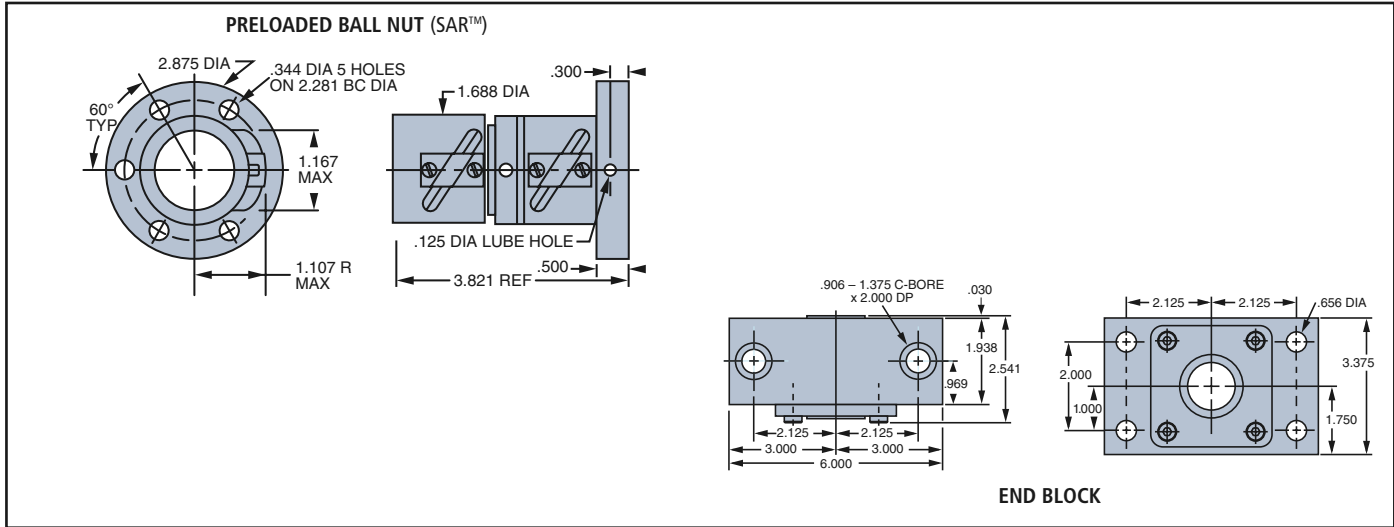

Ball Circle Diameter (size)	Lead (in.)	General Description	Ball Nut Part Number	Ball Screw Part Number	Dynamic Load (lb <sub>f</sub> ) 10° in.	Max Static Load (lb <sub>f</sub> )	Ball Nut Weight (lb)	Flange Part Number	Wiper Kit Part Number	End Block Part Number
1.150	.200	RH, Preload	7823587	7820430	1,185	13,090	1.75	Integral	Integral	7824158

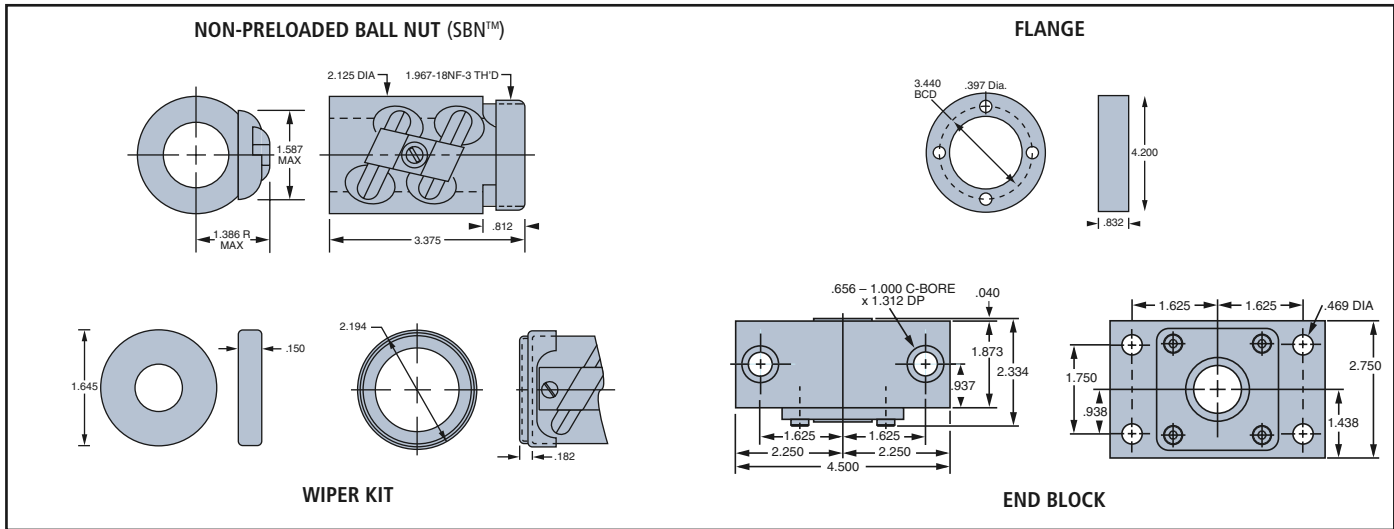

Ball Circle Diameter (size)	Lead (in.)	General Description	Ball Nut Part Number	Ball Screw Part Number	Dynamic Load (lb <sub>f</sub> ) 10° in.	Max Static Load (lb <sub>f</sub> )	Ball Nut Weight (lb)	Flange Part Number	Wiper Kit Part Number	End Block Part Number
1.171	.413	RH, NP	5707511	7820432	3,894	22,917	1.94	5707572	5702653*	7824157

\* Customer to provide 1 wiper retainer. See pg. 89

## Precision - Inch

- Non-Preloaded Backlash
- Preloaded Zero Backlash

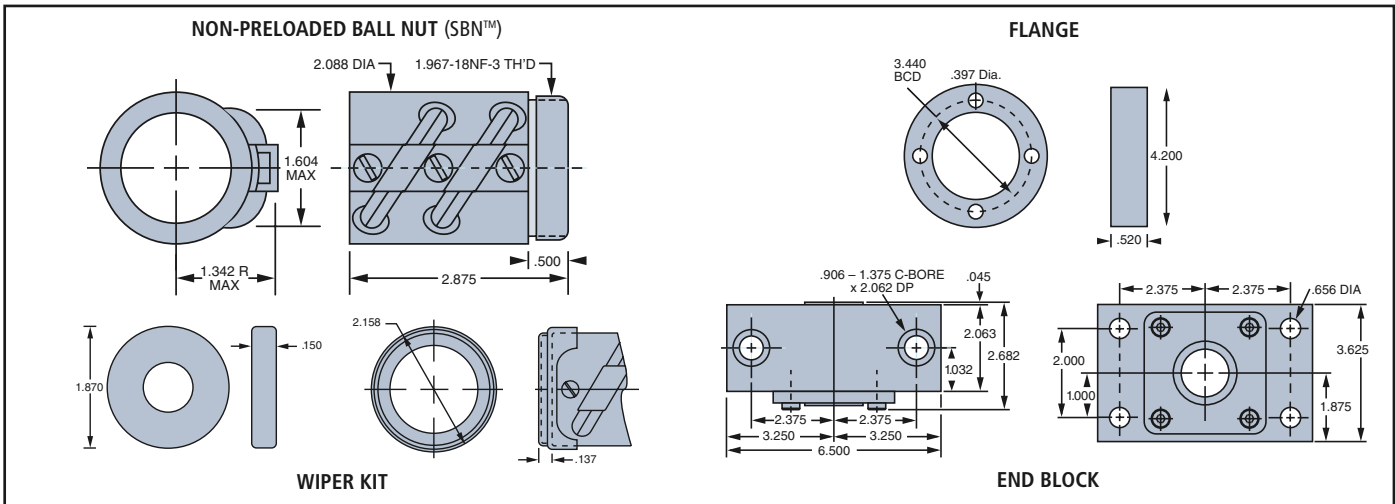

Ball Circle Diameter (size)	Lead (in.)	General Description	Ball Nut Part Number	Ball Screw Part Number	Dynamic Load (lb <sub>f</sub> ) 10° in.	Max Static Load (lb <sub>f</sub> )	Ball Nut Weight (lb)	Flange Part Number	Wiper Kit Part Number	End Block Part Number
1.500	.250	RH, NP LH, NP	5709587 5701990	7820595 7820596	4,198 4,198	44,030 44,030	1.65 1.65	5706754 5706754	5702654* 5702654*	7824159 7824159

\* Customer to provide wiper retainer. See pg. 89

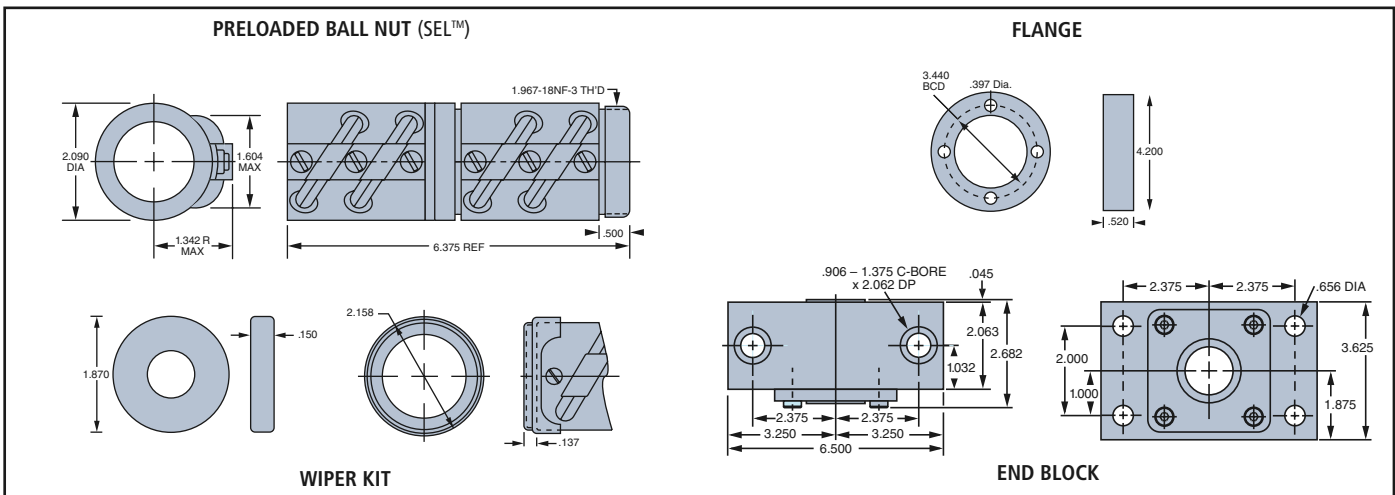

\* Customer to provide wiper retainer. See pg. 85

Ball Circle Diameter (size)	Lead (in.)	General Description	Ball Nut Part Number	Ball Screw Part Number	Dynamic Load (lb <sub>f</sub> ) 10° in.	Max Static Load (lb <sub>f</sub> )	Ball Nut Weight (lb)	Flange Part Number	Wiper Kit Part Number	End Block Part Number
1.500	.250	RH, Preload	5704271	7820595	4,198	44,030	3.02	5706754	5702654*	7824159

### General Description Legend

C1	One Circuit	NP	Non-preloaded Ball Nut	Rnd	Round
C2	Two Circuits	OAL	Overall Length	Sq.	Square
KW	Keyway	Preload	Preloaded Ball Nut	SS	Stainless Steel
LH	Left Hand	RH	Right Hand	v	Valued Priced

Precision - Inch

- Non-Preloaded Backlash
- Preloaded Zero Backlash

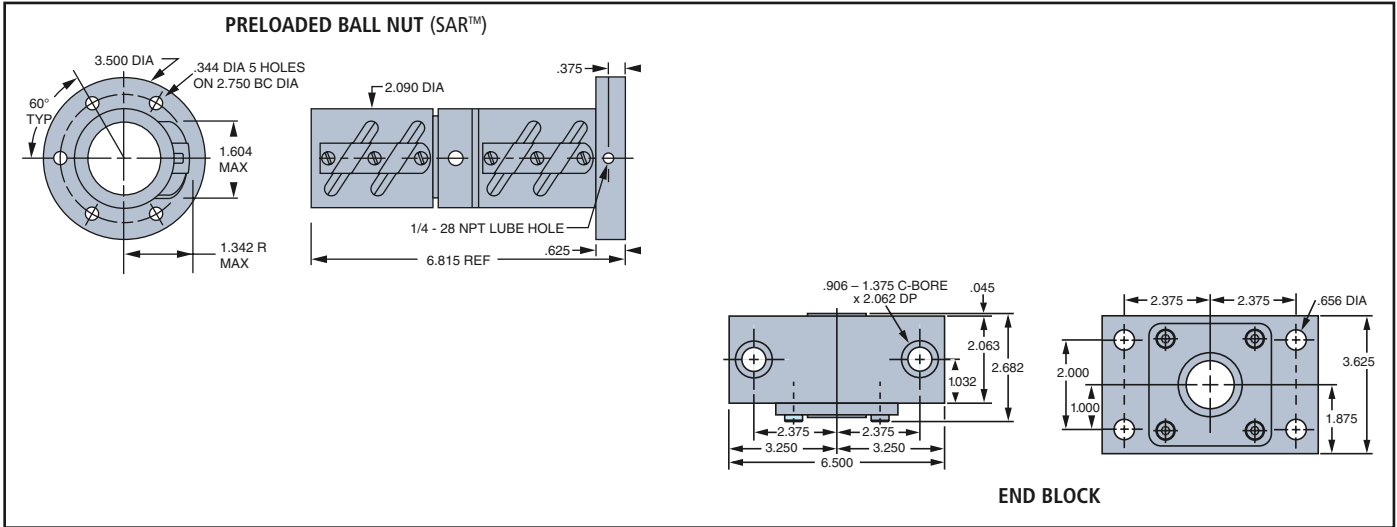

Ball Circle Diameter (size)	Lead (in.)	General Description	Ball Nut Part Number	Ball Screw Part Number	Dynamic Load (lb <sub>f</sub> ) 10° in.	Max Static Load (lb <sub>f</sub> )	Ball Nut Weight (lb)	Flange Part Number	Wiper Kit Part Number	End Block Part Number
1.500	.250	RH, Preload	7823588	7820595	4,198	44,030	4.80	Integral	Integral	7824159

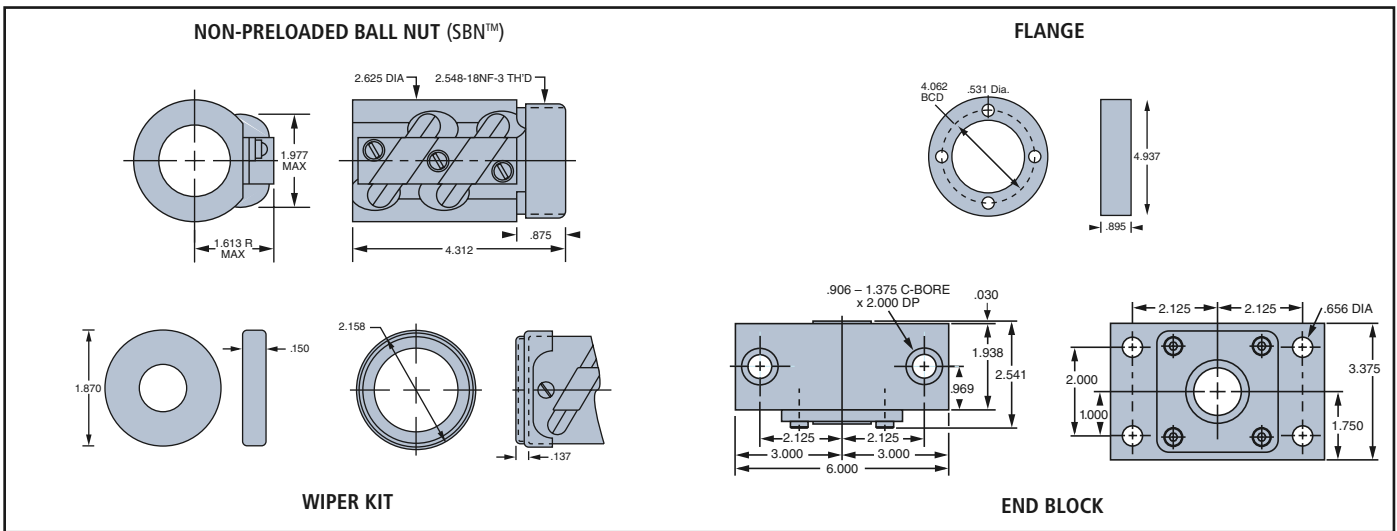

Ball Circle Diameter (size)	Lead (in.)	General Description	Ball Nut Part Number	Ball Screw Part Number	Dynamic Load (lb <sub>f</sub> ) 10° in.	Max Static Load (lb <sub>f</sub> )	Ball Nut Weight (lb)	Flange Part Number	Wiper Kit Part Number	End Block Part Number
1.500	.473	RH, NP	5707513	7820597	10,050	57,770	3.94	5707573	5702655*	7824158

\* Customer to provide 1 wiper retainer. See pg. 89

INCH

Precision - Inch

- Non-Preloaded Backlash
- Preloaded Zero Backlash

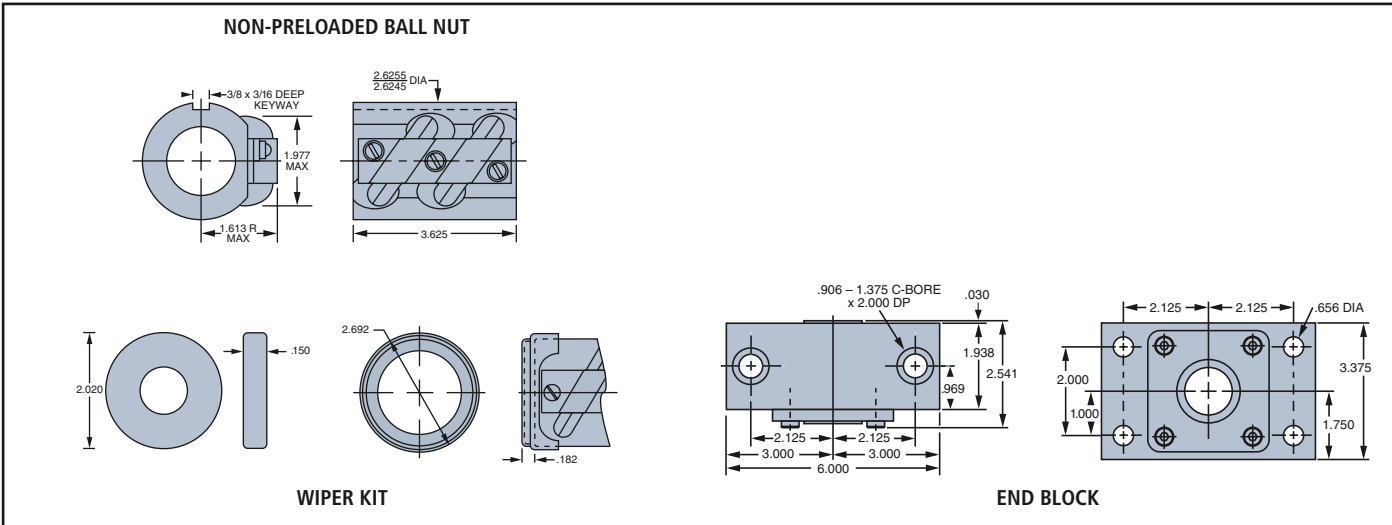

Ball Circle Diameter (size)	Lead (in.)	General Description	Ball Nut Part Number	Ball Screw Part Number	Dynamic Load (lb <sub>f</sub> ) 10 <sup>6</sup> in.	Max Static Load (lb <sub>f</sub> )	Ball Nut Weight (lb)	Flange Part Number	Wiper Kit Part Number	End Block Part Number
1.500	.473	RH, KW, NP	5708345	7820597	10,050	57,770	3.94	N/A	5702656*	7824158

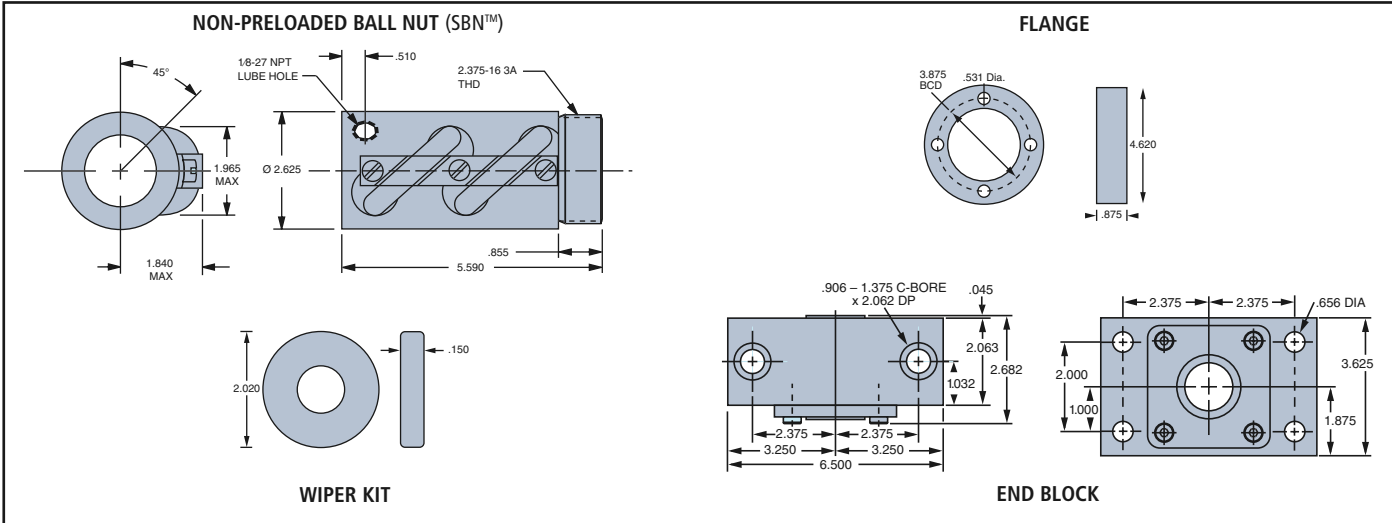

Ball Circle Diameter (size)	Lead (in.)	General Description	Ball Nut Part Number	Ball Screw Part Number	Dynamic Load (lb <sub>f</sub> ) 10 <sup>6</sup> in.	Max Static Load (lb <sub>f</sub> )	Ball Nut Weight (lb)	Flange Part Number	Wiper Kit Part Number	End Block Part Number
1.500	.500	RH, NP	7824246	7824253	14,513	81,600	5.70	7824250	7824251	7824159

\* Customer to provide wiper retainer. See pg. 89

General Description Legend

C1	One Circuit	NP	Non-preloaded Ball Nut	Rnd	Round
C2	Two Circuits	OAL	Overall Length	Sq.	Square
KW	Keyway	Preload	Preloaded Ball Nut	SS	Stainless Steel
LH	Left Hand	RH	Right Hand	v	Valued Priced



Precision - Inch

- Non-Preloaded Backlash
- Preloaded Zero Backlash

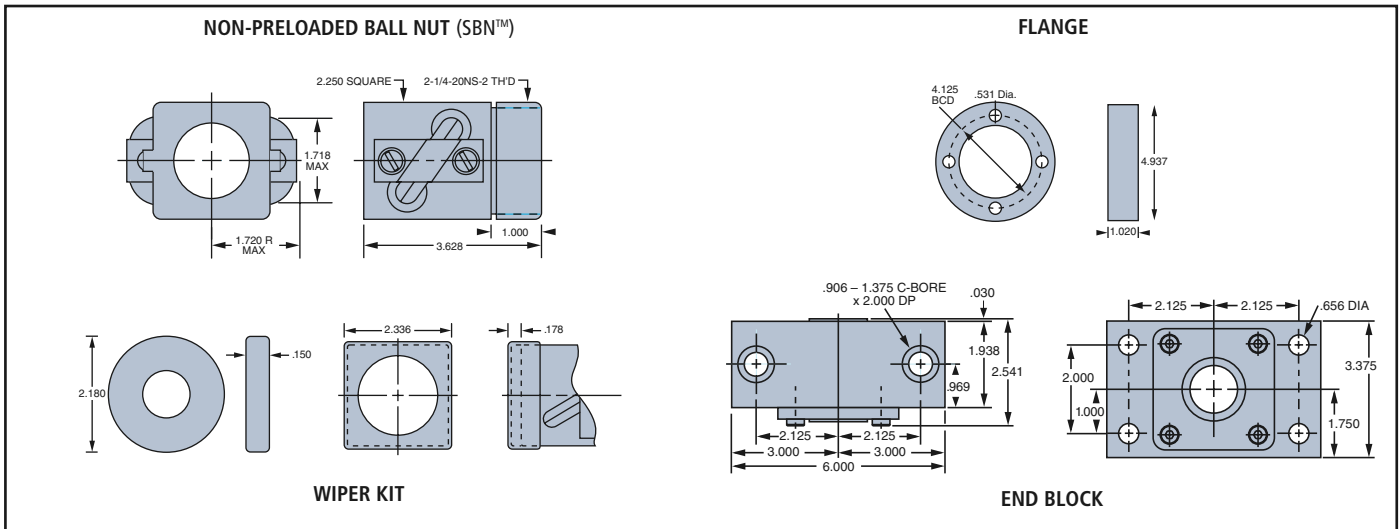

Ball Circle Diameter (size)	Lead (in.)	General Description	Ball Nut Part Number	Ball Screw Part Number	Dynamic Load (lb <sub>f</sub> ) 10° in.	Max Static Load (lb <sub>f</sub> )	Ball Nut Weight (lb)	Flange Part Number	Wiper Kit Part Number	End Block Part Number
1.500	1.000	RH, NP LH, NP	5708280 5701995	7820598 7825925	7,560 7,560	34,662 34,662	3.88 3.88	5707777 5707777	5702657* 5702657*	7824158 7824158

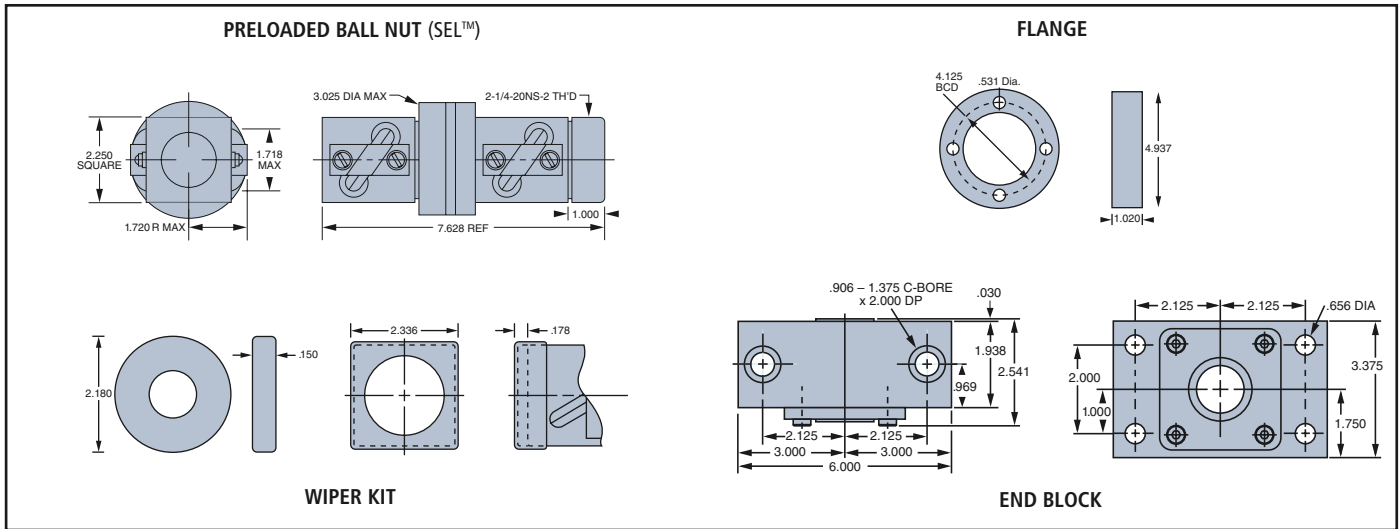

Ball Circle Diameter (size)	Lead (in.)	General Description	Ball Nut Part Number	Ball Screw Part Number	Dynamic Load (lb <sub>f</sub> ) 10° in.	Max Static Load (lb <sub>f</sub> )	Ball Nut Weight (lb)	Flange Part Number	Wiper Kit Part Number	End Block Part Number
1.500	1.000	RH, Preload*	5700698	7820598	7,560	34,662	7.13	5707777	5702657*	7824158

\* Customer to provide 1 wiper retainer. See pg. 89

## Precision - Inch

- Non-Preloaded Backlash
- Preloaded Zero Backlash

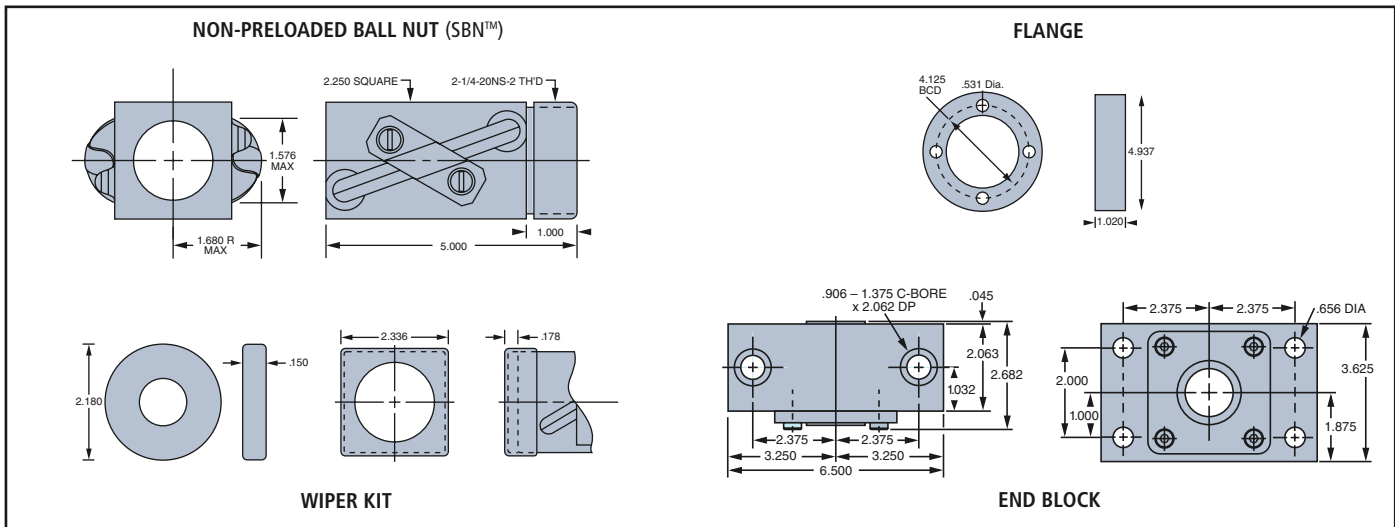

Ball Circle Diameter (size)	Lead (in.)	General Description	Ball Nut Part Number	Ball Screw Part Number	Dynamic Load (lb <sub>f</sub> ) 10 <sup>6</sup> in.	Max Static Load (lb <sub>f</sub> )	Ball Nut Weight (lb)	Flange Part Number	Wiper Kit Part Number	End Block Part Number
1.500	1.875	RH, NP	5707654	7820599	7,242	29,895	4.22	5707777	5702658*	7824159

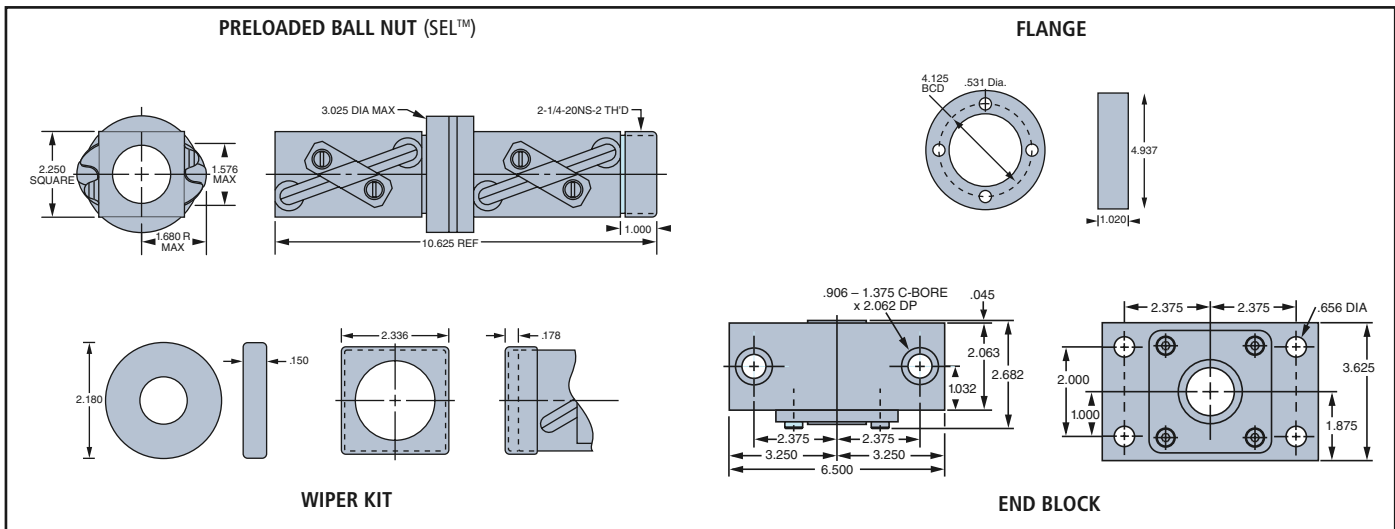

Ball Circle Diameter (size)	Lead (in.)	General Description	Ball Nut Part Number	Ball Screw Part Number	Dynamic Load (lb <sub>f</sub> ) 10 <sup>6</sup> in.	Max Static Load (lb <sub>f</sub> )	Ball Nut Weight (lb)	Flange Part Number	Wiper Kit Part Number	End Block Part Number
1.500	1.875	RH, Preload <sup>v</sup>	5704272	7820599	7,242	29,895	9.93	5707777	5702658*	7824159

\* Customer to provide 1 wiper retainer. See pg. 89

### General Description Legend

C1	One Circuit	NP	Non-preloaded Ball Nut	Rnd	Round
C2	Two Circuits	OAL	Overall Length	Sq.	Square
KW	Keyway	Preload	Preloaded Ball Nut	SS	Stainless Steel
LH	Left Hand	RH	Right Hand	v	Valued Priced

Precision - Inch

- Non-Preloaded Backlash
- Preloaded Zero Backlash

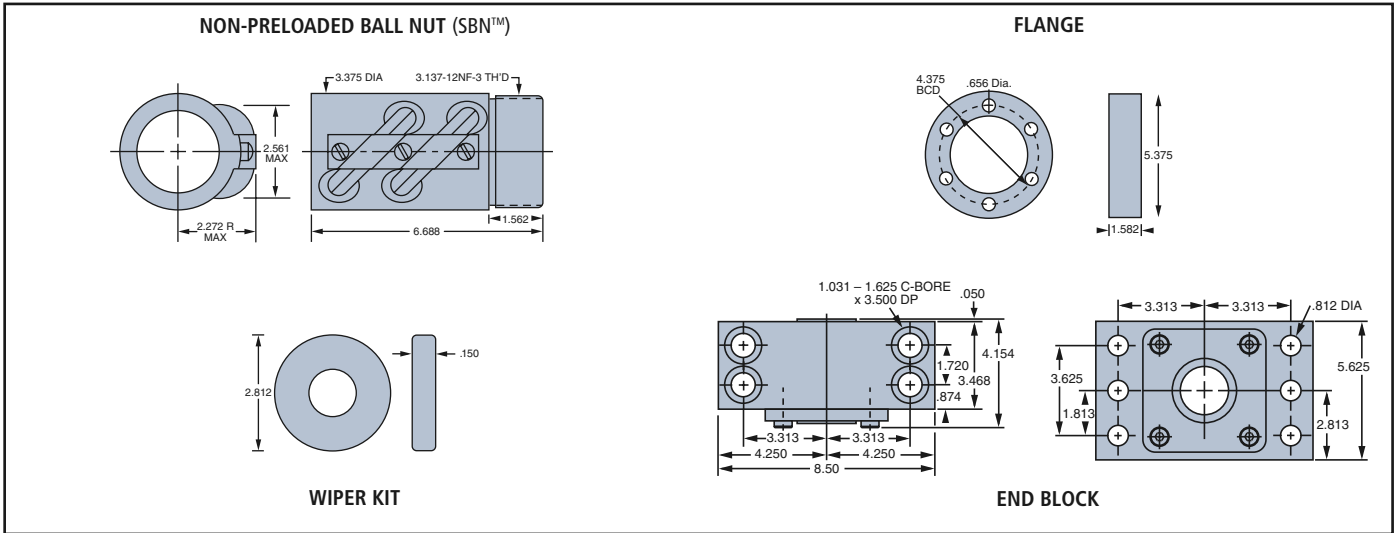

Ball Circle Diameter (size)	Lead (in.)	General Description	Ball Nut Part Number	Ball Screw Part Number	Dynamic Load (lb <sub>f</sub> ) 10 <sup>6</sup> in.	Max Static Load (lb <sub>f</sub> )	Ball Nut Weight (lb)	Flange Part Number	Wiper Kit Part Number	End Block Part Number
2.250	.500	RH, NP LH, NP	5707516 5704000	7820600 7820602	21,306 21,306	142,660 142,660	8.25 8.25	5707574 5707574	5702659 <sup>†</sup> 5702659 <sup>†</sup>	7824160 7824160

<sup>†</sup>Brush-type wiper; formed felt available (5703890-RH; 5700456-LH); wiper dia. —2.718 in., width—.625 in.; retainer dia.—2.802 in. Increases length at each end by .300 in.

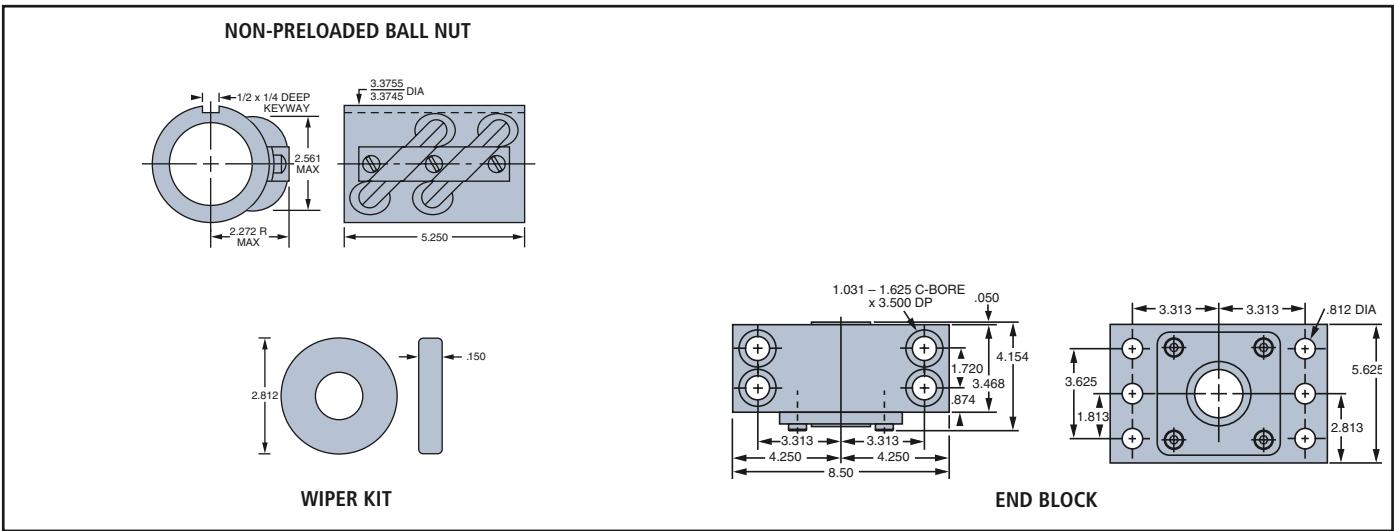

Ball Circle Diameter (size)	Lead (in.)	General Description	Ball Nut Part Number	Ball Screw Part Number	Dynamic Load (lb <sub>f</sub> ) 10 <sup>6</sup> in.	Max Static Load (lb <sub>f</sub> )	Ball Nut Weight (lb)	Flange Part Number	Wiper Kit Part Number	End Block Part Number
2.250	.500	RH, KW, NP LH, KW, NP	5708346 7830722	7820600 7820602	21,306 21,306	142,660 142,660	8.25 8.25	N/A N/A	5702659 <sup>†</sup> 5702659 <sup>†</sup>	7824160 7824160

<sup>†</sup>Snap ring retainers in ball nut C-bore.

## Precision - Inch

- Non-Preloaded Backlash
- Preloaded Zero Backlash

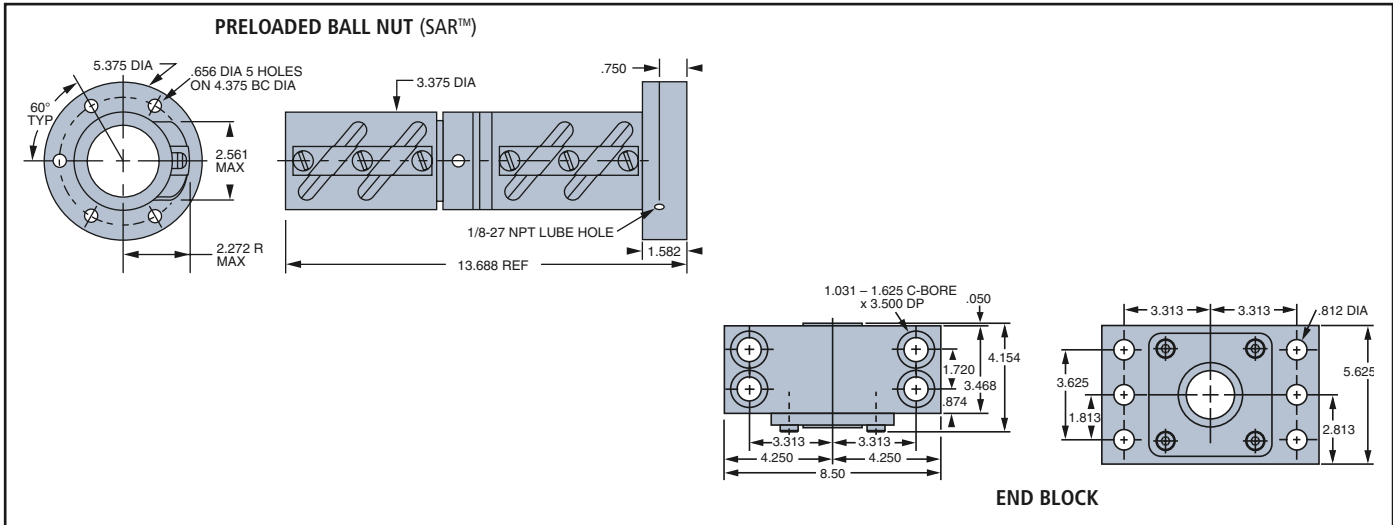

Ball Circle Diameter (size)	Lead (in.)	General Description	Ball Nut Part Number	Ball Screw Part Number	Dynamic Load (lb <sub>f</sub> ) 10 <sup>6</sup> in.	Max Static Load (lb <sub>f</sub> )	Ball Nut Weight (lb)	Flange Part Number	Wiper Kit Part Number	End Block Part Number
2.250	.500	RH, Preload	7823589	7820600	21,306	142,660	24.25	Integral	Integral	7824160

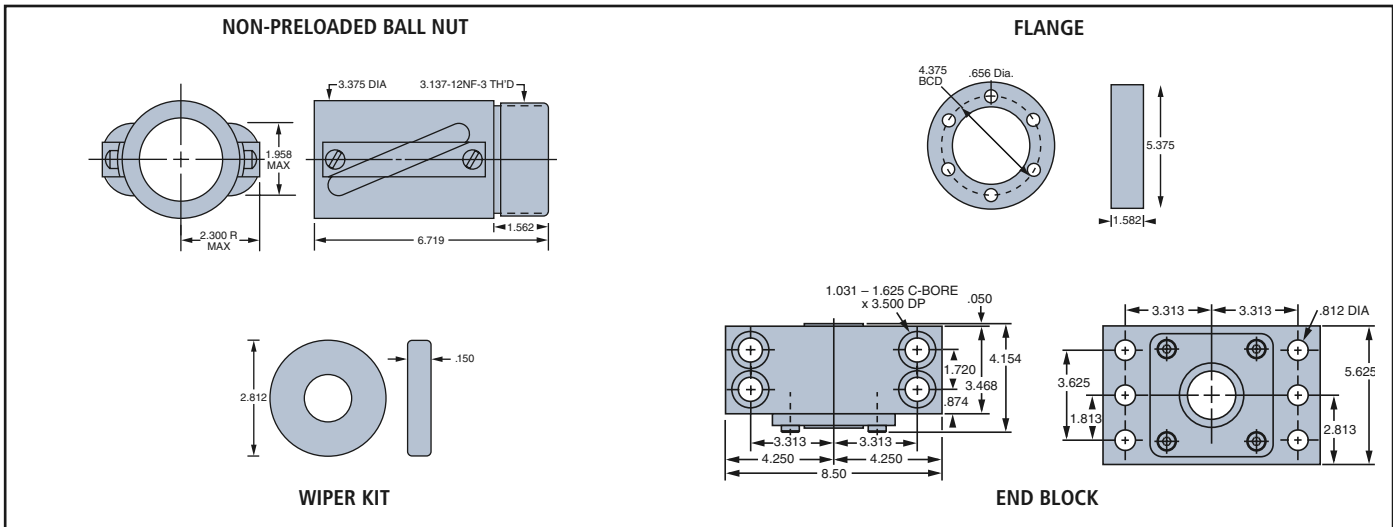

Ball Circle Diameter (size)	Lead (in.)	General Description	Ball Nut Part Number	Ball Screw Part Number	Dynamic Load (lb <sub>f</sub> ) 10 <sup>6</sup> in.	Max Static Load (lb <sub>f</sub> )	Ball Nut Weight (lb)	Flange Part Number	Wiper Kit Part Number	End Block Part Number
2.250	1.000	RH, NP	5704555	7820604	26,538	142,660	8.25	5707574	5702659 <sup>†</sup>	7824160

<sup>†</sup>Brush-type wiper; formed felt available (5700457-RH); wiper dia.—2.718 in., width—.625 in.; retainer dia.—2.802 in. Snap ring retainers in ball nut C-Bore. Increases length at each end by .300 in.

### General Description Legend

C1	One Circuit	NP	Non-preloaded Ball Nut	Rnd	Round
C2	Two Circuits	OAL	Overall Length	Sq.	Square
KW	Keyway	Preload	Preloaded Ball Nut	SS	Stainless Steel
LH	Left Hand	RH	Right Hand	v	Valued Priced

Precision - Inch

- Non-Preloaded Backlash
- Preloaded Zero Backlash

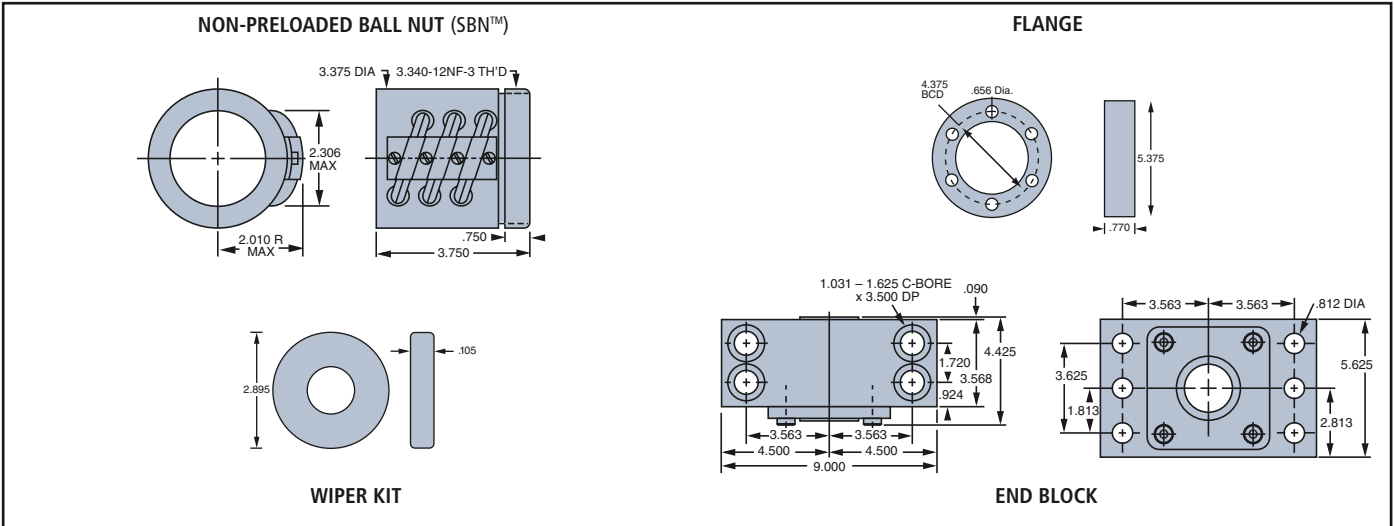

Ball Circle Diameter (size)	Lead (in.)	General Description	Ball Nut Part Number	Ball Screw Part Number	Dynamic Load (lb <sub>f</sub> ) 10 <sup>6</sup> in.	Max Static Load (lb <sub>f</sub> )	Ball Nut Weight (lb)	Flange Part Number	Wiper Kit Part Number	End Block Part Number
2.500	.250	RH, NP	5703243	7820606	6,315	81,938	4.72	5703263	5703324 <sup>†</sup>	7824161

<sup>†</sup> Snap ring retainers in ball nut C-bore.

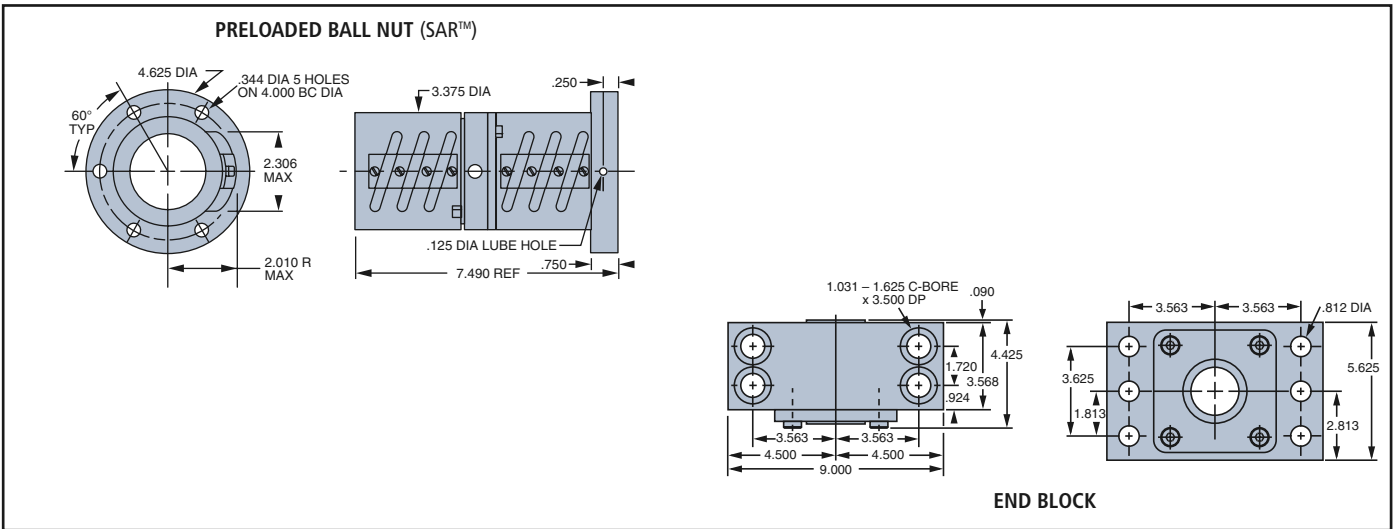

Ball Circle Diameter (size)	Lead (in.)	General Description	Ball Nut Part Number	Ball Screw Part Number	Dynamic Load (lb <sub>f</sub> ) 10 <sup>6</sup> in.	Max Static Load (lb <sub>f</sub> )	Ball Nut Weight (lb)	Flange Part Number	Wiper Kit Part Number	End Block Part Number
2.500	.250	RH, Preload	7823590	7820606	6,315	81,938	9.94	Integral	Integral	7824161

## Precision - Inch

- Non-Preloaded Backlash
- Preloaded Zero Backlash

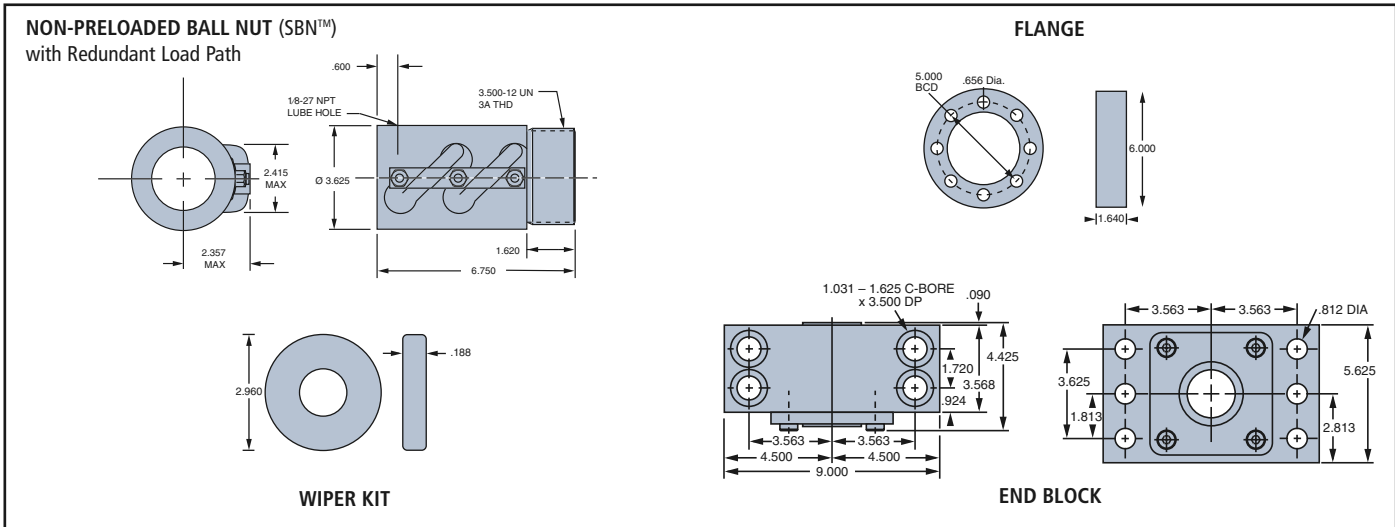

Ball Circle Diameter (size)	Lead (in.)	General Description	Ball Nut Part Number	Ball Screw Part Number	Dynamic Load (lb <sub>f</sub> ) 10 <sup>6</sup> in.	Max Static Load (lb <sub>f</sub> )	Ball Nut Weight (lb)	Flange Part Number	Wiper Kit Part Number	End Block Part Number
2.500	.500	RH, NP	7824136	7824262	22,981	166,062	10.06	7824141	7824140	7824161

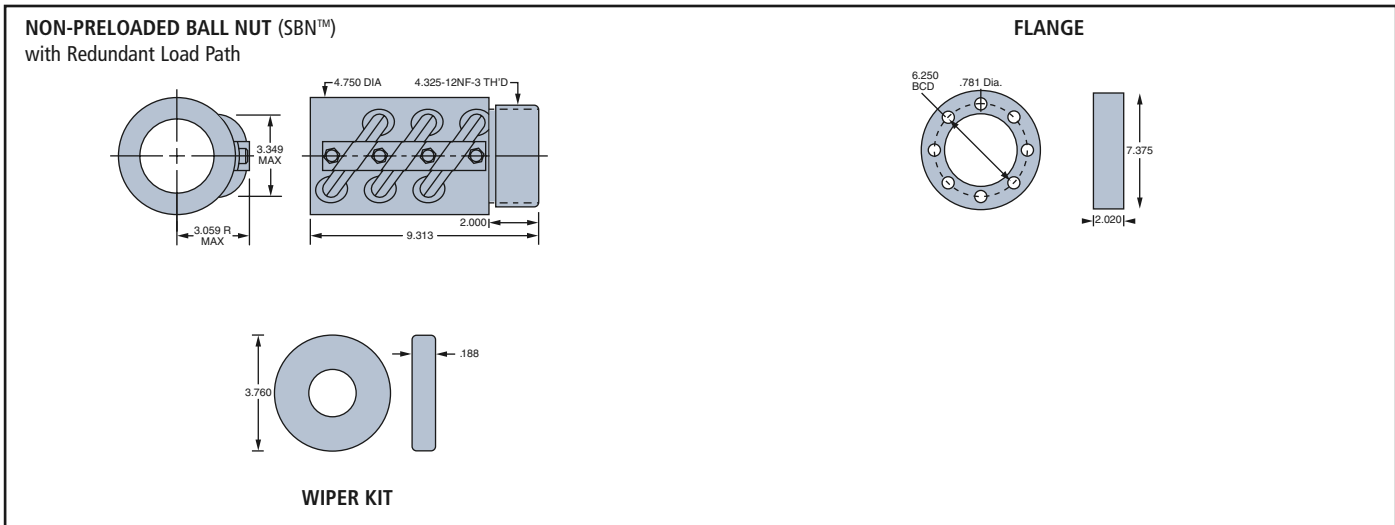

Ball Circle Diameter (size)	Lead (in.)	General Description	Ball Nut Part Number	Ball Screw Part Number	Dynamic Load (lb <sub>f</sub> ) 10 <sup>6</sup> in.	Max Static Load (lb <sub>f</sub> )	Ball Nut Weight (lb)	Flange Part Number	Wiper Kit Part Number	End Block Part Number
3.000	.660	RH, NP	5707519	7820607	44,316	271,433	26.0	5707575	5702661 <sup>†</sup>	N/A

<sup>†</sup>Brush-type wiper; formed felt available (5703891-RH); wiper dia.—3.640 in., width—7.505 in.; retainer dia.—3.740 in. Increases length at each end by .375 in.

### General Description Legend

C1	One Circuit	NP	Non-preloaded Ball Nut	Rnd	Round
C2	Two Circuits	OAL	Overall Length	Sq.	Square
KW	Keyway	Preload	Preloaded Ball Nut	SS	Stainless Steel
LH	Left Hand	RH	Right Hand	v	Valued Priced

Precision - Inch

- Non-Preloaded Backlash
- Preloaded Zero Backlash



Ball Circle Diameter (size)	Lead (in.)	General Description	Ball Nut Part Number	Ball Screw Part Number	Dynamic Load (lb <sub>f</sub> ) 10 <sup>6</sup> in.	Max Static Load (lb <sub>f</sub> )	Ball Nut Weight (lb)	Flange Part Number	Wiper Kit Part Number	End Block Part Number
3.000	.660	RH, KW, NP	5708347	7820607	44,316	271,733	26.00	N/A	5702662*	N/A

\* No retainers provided. See pg. 89

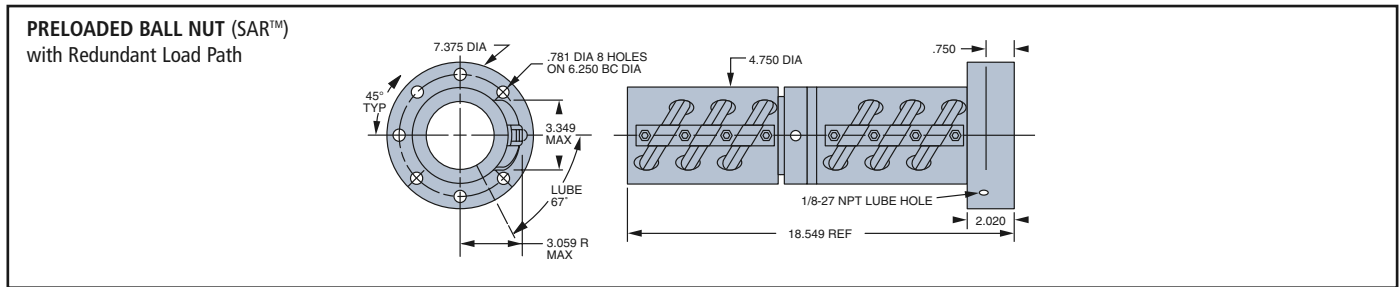

Ball Circle Diameter (size)	Lead (in.)	General Description	Ball Nut Part Number	Ball Screw Part Number	Dynamic Load (lb <sub>f</sub> ) 10 <sup>6</sup> in.	Max Static Load (lb <sub>f</sub> )	Ball Nut Weight (lb)	Flange Part Number	Wiper Kit Part Number	End Block Part Number
3.000	.660	RH, Preload	5703045	7820607	44,316	271,733	67.50	Integral	Integral	N/A

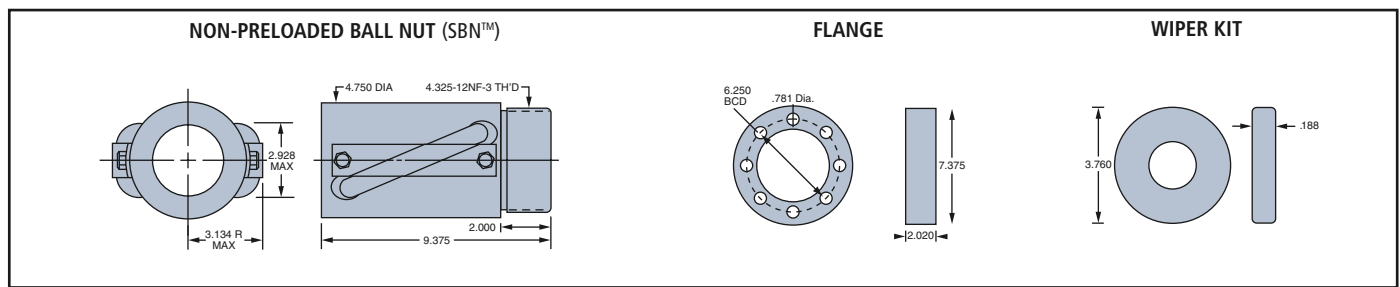

Ball Circle Diameter (size)	Lead (in.)	General Description	Ball Nut Part Number	Ball Screw Part Number	Dynamic Load (lb <sub>f</sub> ) 10 <sup>6</sup> in.	Max Static Load (lb <sub>f</sub> )	Ball Nut Weight (lb)	Flange Part Number	Wiper Kit Part Number	End Block Part Number
3.000	1.500	RH, NP	5704986	7820609	53,646	253,617	27.20	5707575	5702661 <sup>†</sup>	N/A

<sup>†</sup>Brush-type wiper; formed felt available (5700458-RH); wiper dia.—3.640 in., width—.750 in.; retainer dia.—3.740 in. Increases length at each end by .375 in.

INCH

## Precision - Inch

- Non-Preloaded Backlash
- Preloaded Zero Backlash

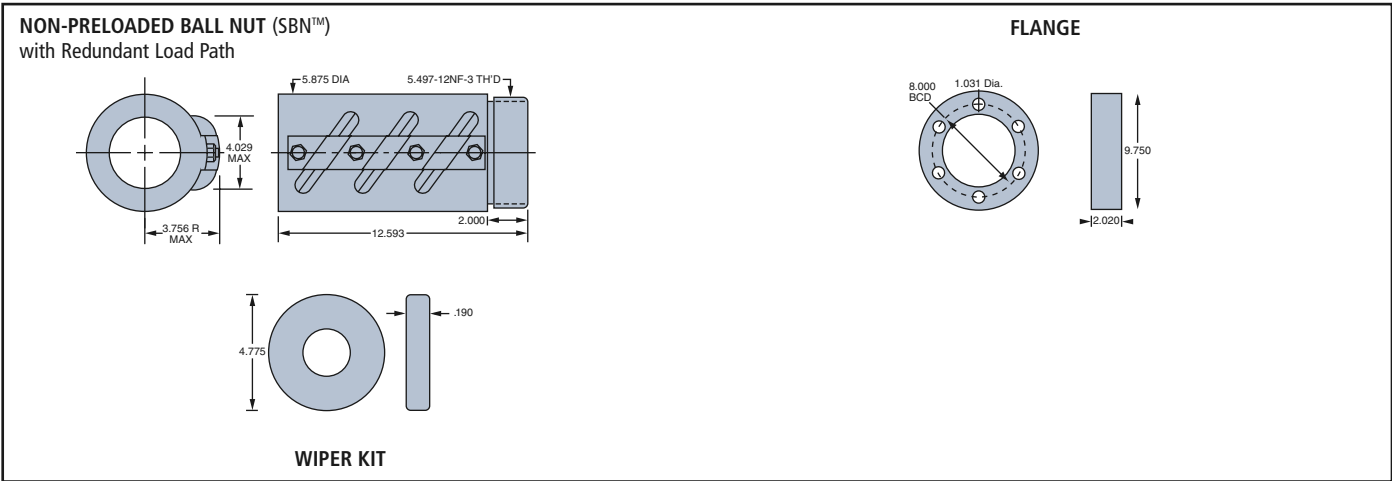

Ball Circle Diameter (size)	Lead (in.)	General Description	Ball Nut Part Number	Ball Screw Part Number	Dynamic Load (lb <sub>f</sub> ) 10 <sup>6</sup> in.	Max Static Load (lb <sub>f</sub> )	Ball Nut Weight (lb)	Flange Part Number	Wiper Kit Part Number	End Block Part Number
4.000	1.000	RH, NP	5703258	5703262	85,758	476,970	53.50	5703307	5703306 <sup>†</sup>	N/A

<sup>†</sup>Brush-type wiper; formed felt available (5704057-RH); wiper dia.—4.652 in., width—1.000 in.; retainer dia.—4.740 in. Increases length at each end by .600 in.

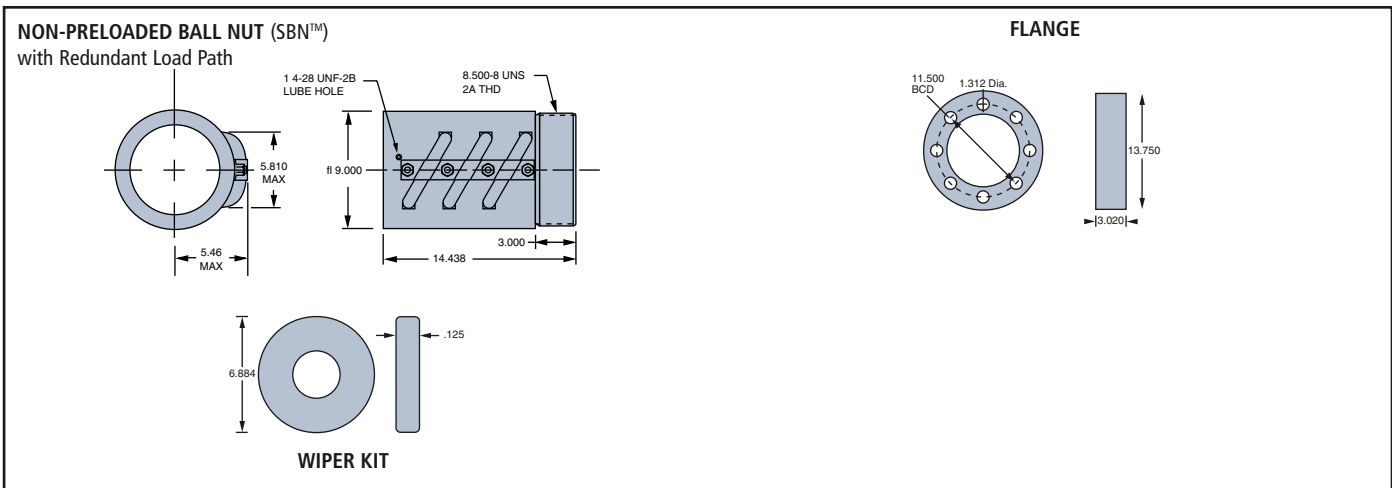

Ball Circle Diameter (size)	Lead (in.)	General Description	Ball Nut Part Number	Ball Screw Part Number	Dynamic Load (lb <sub>f</sub> ) 10 <sup>6</sup> in.	Max Static Load (lb <sub>f</sub> )	Ball Nut Weight (lb)	Flange Part Number	Wiper Kit Part Number	End Block Part Number
6.000	1.000	RH, NP	5704738	5704762	160,000	750,000	142.50	5704764	5704746	N/A

\* Customer to provide wiper retainer. See pg. 89

### General Description Legend

C1	One Circuit	NP	Non-preloaded Ball Nut	Rnd	Round
C2	Two Circuits	OAL	Overall Length	Sq.	Square
KW	Keyway	Preload	Preloaded Ball Nut	SS	Stainless Steel
LH	Left Hand	RH	Right Hand	v	Valued Priced



## Ball Screw Wiper Kits

Danaher Motion provides a complete section of optional wiper kits to extend ball screw life and maintain efficiency.

### Kit Content Descriptions

**Type J:** 2 wipers, 1 retainer; customer to supply 1 retainer.

See typical methods below

**Type K:** 2 wipers, 2 retainers

**Type L:** 2 wipers, 2 snap rings

**Type M:** 2 wipers only; customer's design to provide method of attaching wipers to ball nut

Wipers

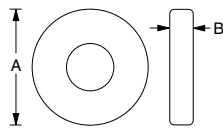

Retainers

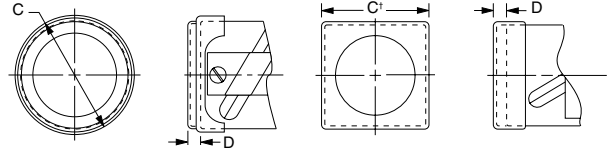

BALL NUT DESCRIPTION BCD X LEAD	WIPER KIT PART NUMBER	KIT CONTENT	DIA. A	DIM. B	DIM. C RETAINER	DIM. D RETAINER
.187 .062	Not available					
.375 .125 B1	Not available					
.375 .125 B2	Not available					
.500 .200	7826759	J	1.018	.105	1.100	.137
.500 .500	Not available					
.631 .200	5702647	J	.961	.105	1.086†	.133
.631 1.000	7827527	J	.961	.105	1.200	.112
.750 .200	7824337	L	1.031	.105		
.750 .500	7824337	L	1.031	.105		
.875 .200	7831512	J	1.363	.105	1.698	.137
1.000 .250 (Sq)	5702649	J	1.500	.156	1.586†	.188
1.000 .250 (Rnd)	5702651	J	1.363	.105	1.698	.137
1.000 .500	7824292	L	1.363	.105		
1.000 1.000	5702650	J	1.500	.156	1.586†	.188
1.150 .200	5702652	J	1.520	.105	1.760	.137
1.171 .413	5702653	J	1.645	.150	2.194	.182
1.500 .250	5702654	J	1.870	.105	2.158	.137
1.500 .473	5702655	J	2.020	.150	2.692	.182
1.500 .473 (KW)	5702656	K	2.020	.150	2.692	.182
1.500 .500	7824251	L	2.020	.150		
1.500 1.000	5702657	J	2.180	.150	2.336†	.178
1.500 1.875	5702658	J	2.180	.150	2.336†	.178
2.250 .500 (KW)	5702659	L	2.812	.150	‡	
2.250 .500 (R/LH)	5702659	L	2.812	.150	‡	
2.250 .500 (RH)	5703890	K	2.718	.625	2.802	.300
2.250 .500 (LH)	5700456	K	2.178	.625	2.802	.300
2.250 1.000	5702659	L	2.812	.150	‡	
2.250 1.000	5700457	K	2.718	.625	2.802	.300
2.500 .250	5703324	L	2.895	.105	‡	
2.500 .500	7824140	L	2.960	.188		
3.000 .660	5702661	L	3.760	.188	‡	
3.000 .660 (KW)	5702662	M	3.760	.188	‡	
3.000 .660	5703891	K	3.640	.750	3.740	.375
3.000 1.500	5702661	L	3.760	.188	‡	
3.000 1.500	5700458	K	3.640	.750	3.740	.375
4.000 1.000	5703306	L	4.775	.190	‡	
4.000 1.000	5704057	K	4.652	1.000	4.720	.600
6.000 1.000	5704746	K	6.884	1.048	‡	1.050

† Square configuration.

‡ Snap ring retainers in ball nut counterbore.

### Typical Methods of Attaching Wipers to V-thread End

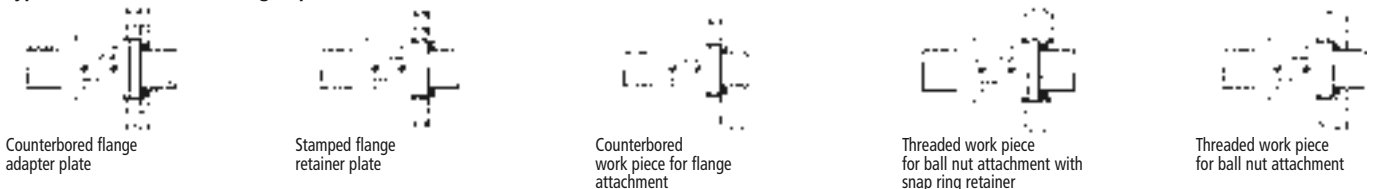

## Thomson vs. Warner Cross Reference Chart

NOTE: Thomson and Warner Linear designs utilize different thread forms. Individual screws and nuts are interchangeable between designs.

Nom. O.D.	Nom. Lead	Component Part	Thomson	Warner Linear	Nom. O.D.	Nom. Lead	Component Part	Thomson	Warner Linear	Nom. O.D.	Nom. Lead	Component Part	Thomson	Warner Linear
0.187	0.050	Ball Nut	7821609	n/a	1.125	0.200	Ball Nut	5701566	8111-448-006	2.250	0.500	Ball Nut	5707516	8122-448-005
		Screw Shaft	7821634	n/a			Screw Shaft	7820430	190-9106			Screw Shaft	7820600	190-9114
		Flange	n/a	n/a			Flange	5708283	8111-448-002			Flange	5707574	8122-448-002
		Wiper Kit	n/a	n/a			Wiper Kit	5702652	8111-101-002			Wiper Kit	5702659	8122-101-002
0.187	0.062	Ball Nut	7831631	n/a	1.171	0.413	Ball Nut	5707511	n/a	2.250	1.000	Ball Nut	5704555	n/a
		Screw Shaft	7821633	n/a			Screw Shaft	7820432	n/a			Screw Shaft	7820604	n/a
		Flange	n/a	n/a			Flange	5707572	n/a			Flange	5707574	n/a
		Wiper Kit	n/a	n/a			Wiper Kit	5702653	n/a			Wiper Kit	5702659	n/a
0.375	0.125	Ball Nut	5707502	8103-448-003	1.500	0.250	Ball Nut	5709587	8115-448-020	2.500	0.250	Ball Nut	7824136	n/a
		Screw Shaft	5707538	190-9217			Screw Shaft	7820595	190-9110			Screw Shaft	7824262	n/a
		Flange	5706751	8103-448-002			Flange	5706754	8115-448-009			Flange	7824141	n/a
		Wiper Kit	n/a	8103-101-002			Wiper Kit	5702654	8115-101-006			Wiper Kit	7824140	n/a
0.500	0.200	Ball Nut	7826720	8105-448-013	1.500	0.473	Ball Nut	5707513	8115-448-055	2.500	0.500	Ball Nut	7824136	8125-448-010
		Screw Shaft	7826721	190-9097			Screw Shaft	7820597	190-9328			Screw Shaft	7824262	190-9116
		Flange	5707570	8105-448-002			Flange	5707573	8115-448-064			Flange	7824141	8125-448-002
		Wiper Kit	7826759	8105-101-002			Wiper Kit	5702655	x			Wiper Kit	7824140	8125-101-002
0.500	0.500	Ball Nut	(s) 5709582	8105-448-01	1.500	0.500	Ball Nut	7824246	8115-448-016	2.500	1.000	Ball Nut	n/a	8125-448-008
		Screw Shaft	* 5706740	* 190-9096			Screw Shaft	7824253	190-9108			Screw Shaft	n/a	190-9115
		Flange	5707570	8105-448-002			Flange	7824250	8115-448-004			Flange	n/a	8125-448-002
		Wiper Kit	n/a	8105-101-002			Wiper Kit	7824251	8115-101-004			Wiper Kit	n/a	8125-101-002
0.631	0.200	Ball Nut	(s) 7820827	8106-448-00	1.500	1.000	Ball Nut	(s) 5708280	8115-448-014	3.000	0.660	Ball Nut	5707519	8125-448-007
		Screw Shaft	5707540	190-9098			Screw Shaft	* 7820598	* 190-9107			Screw Shaft	7820607	190-9117
		Flange	5707570	8105-448-002			Flange	5707777	8115-448-002			Flange	5707575	8125-448-002
		Wiper Kit	5702647	8106-101-002			Wiper Kit	5702657	8115-101-004			Wiper Kit	5702661	8125-101-002
0.631	1.000	Ball Nut	7826713	n/a	1.500	1.875	Ball Nut	5707654	n/a	3.000	1.500	Ball Nut	5704986	n/a
		Screw Shaft	7826712	n/a			Screw Shaft	7820599	n/a			Screw Shaft	7820609	n/a
		Flange	5707570	n/a			Flange	5707777	n/a			Flange	5707575	n/a
		Wiper Kit	7827527	n/a			Wiper Kit	5702658	n/a			Wiper Kit	5702661	n/a
0.750	0.200	Ball Nut	7824297	8107-448-016	1.500	2.000	Ball Nut	n/a	8125-448-057	4.000	1.000	Ball Nut	5703258	n/a
		Screw Shaft	7824298	190-9101			Screw Shaft	n/a	190-9345			Screw Shaft	5703262	n/a
		Flange	7823336	8107-448-007			Flange	n/a	8125-448-002			Flange	5703307	n/a
		Wiper Kit	7824337	8107-101-002			Wiper Kit	n/a	x			Wiper Kit	5703306	n/a
0.750	0.500	Ball Nut	7824358	8107-448-014	2.000	0.500	Ball Nut	n/a	8120-448-011	6.000	1.000	Ball Nut	5704738	n/a
		Screw Shaft	* 7824361	* 190-9100			Screw Shaft	n/a	190-9112			Screw Shaft	5704762	n/a
		Flange	7823336	8107-448-002			Flange	n/a	8120-448-002			Flange	5704764	n/a
		Wiper Kit	7824336	8107-101-002			Wiper Kit	n/a	8120-101-002			Wiper Kit	5704746	n/a
1.000	0.250	Ball Nut	(s) 5700348	8110-448-02	2.000	1.000	Ball Nut	n/a	8120-448-021	1.000	1.000	Ball Nut	n/a	8120-448-021
		Screw Shaft	7820426	190-9104			Screw Shaft	n/a	190-9111			Screw Shaft	n/a	190-9111
		Flange	5707571	8110-448-002			Flange	n/a	8120-448-002			Flange	n/a	8120-448-002
		Wiper Kit	5702649	8110-101-002			Wiper Kit	n/a	8120-101-002			Wiper Kit	n/a	8120-101-002
1.000	0.500	Ball Nut	7824286	8110-448-022	1.000	0.500	Ball Nut	* 7824290	* 190-9103	1.000	0.500	Ball Nut	* 7824290	* 190-9103
		Screw Shaft	* 7824290	* 190-9103			Screw Shaft	* 7824290	* 190-9103			Screw Shaft	* 7824290	* 190-9103
		Flange	7824293	8110-448-002			Flange	7824293	8110-448-002			Flange	7824293	8110-448-002
		Wiper Kit	7824292	8110-101-002			Wiper Kit	7824292	8110-101-002			Wiper Kit	7824292	8110-101-002
1.000	1.000	Ball Nut	(s) 5707509	8110-448-02	1.000	1.000	Ball Nut	* 5707509	* 190-9102	1.000	1.000	Ball Nut	(s) 5707509	8110-448-02
		Screw Shaft	* 7820429	* 190-9102			Screw Shaft	* 7820429	* 190-9102			Screw Shaft	* 7820429	* 190-9102
		Flange	5707571	8110-448-002			Flange	5707571	8110-448-002			Flange	5707571	8110-448-002
		Wiper Kit	5702650	8110-101-002			Wiper Kit	5702650	8110-101-002			Wiper Kit	5702650	8110-101-002

Note: Danaher Motion has made every effort to ensure accuracy, but cannot be responsible for variances, changes, errors, or omissions

^ Warner Linear was acquired by Danaher Motion in 1997. As part of the integration Warner Linear has changed its name to Danaher Motion and is now sold under the Thomson brand.

\* = Multiple start screw shaft  
(s) = Square style ball nut  
n/a = Not available at time of printing  
x = wiper included with flange

## Precision Plus - Inch



### Thomson Precision Plus Inch Ball Screws Assemblies Offer:

- Eight times the lead accuracy of conventional ball screws for an immediate improvement in machine performance.
- Zero-lash, high spring rate preloaded design which provides positioning accuracy and repeatability for machine tools, robots, material handling systems, electronic component insertion systems and more.
- A Gothic arch ball groove geometry that extends service life, reduces lash, and optimizes stiffness in preloaded assemblies.
- Integral wipers and flanges for system cleanliness and mounting ease.
- Optimum efficiency and cost-savings when replacing expensive hydraulic and pneumatic systems.
- Predictable service life allowing for the most reliable, economical system designs.
- Non-standard lengths available — consult factory.
- Availability through over 1800 authorized Danaher Motion distributors worldwide.

## Precision Plus Inch Product Overview

### Precision Screw Stock

- Lead Accuracies  
.0005 in./ft. accuracy (standard)  
.0002 in./ft. accuracy available (selected sizes special order)

Ball Circle	Lead (in.)	Direction	Part Number	Root Diameter (in.)	Maximum Lengths Available (ft.)	Weight (lb./in.)	Use with these Mounting Blocks
.500	.200	RH	7829724	0.372	42	3.5	7828282
.631	.200	RH	7820396	0.496	42	3.6	7824154
.750	.200	RH	5700974	0.599	42	5.4	7824155
.875	.200	RH	7820397	0.740	60	9.6	7824156
1.000	.200	RH	5700975	0.865	72	15.2	7824157
1.000	.250	RH	7820477	0.833	72	15.4	7824157
1.150	.200	RH	5700976	1.015	72	20.4	7824158
1.250	.200	RH	5700977	1.115	72	23.7	7824158
1.250	.200	LH	7820830	1.115	72	23.7	7824158
1.250	.250	RH	7829725	1.090	72	23.7	7824158
1.250	.500	RH	7820399	1.05	96	25.6	7824158
1.500	.200	RH	7820375	1.349	120	45.8	7824159
1.500	.250	RH	7820965	1.333	120	45.8	7824159
1.500	.500	RH	7820401	1.236	120	46.1	7824159
1.500	1.000	RH	7829726	1.243	96	46.1	7824159
1.750	.200	RH	5700979	1.615	96	64.1	7829554
2.000	.200	RH	7820402	1.849	120	82.4	7824160
2.000	.500	RH	7829727	1.615	96	82.4	7824160
2.000	1.000	RH	7829728	1.615	96	82.4	7824160
2.250	.500	RH	7820484	1.858	120	101	7824160
2.500	.250	RH	7820483	2.333	120	134	7824161
2.500	.500	RH	7829729	2.115	96	134	7824161

\* Note: Customer to verify bearings are sufficient for application  
Alternate lengths available on request (consult factory)

## Precision Plus - Inch Product Availability

		Lead (in)				
		0.200	0.250	0.400	0.500	1.000
Diameter (in)	0.500	●	●			
	0.631	●	●			
	0.750	●	●	●	●	
	0.875	●	●	●	●	●
	1.000	●	●	●	●	●
	1.150	●	●	●	●	●
	1.250	●	●	●	●	●
	1.500	●	●	●	●	●
	1.750	●	●	●	●	●
	2.000	●	●	●	●	●
	2.250		●	●	●	●
	2.500		●	●	●	●
	3.000		●	●	●	●
	4.000					●
	5.000					●
	6.000					●
8.000					●	

● = stocked size  
● = on request

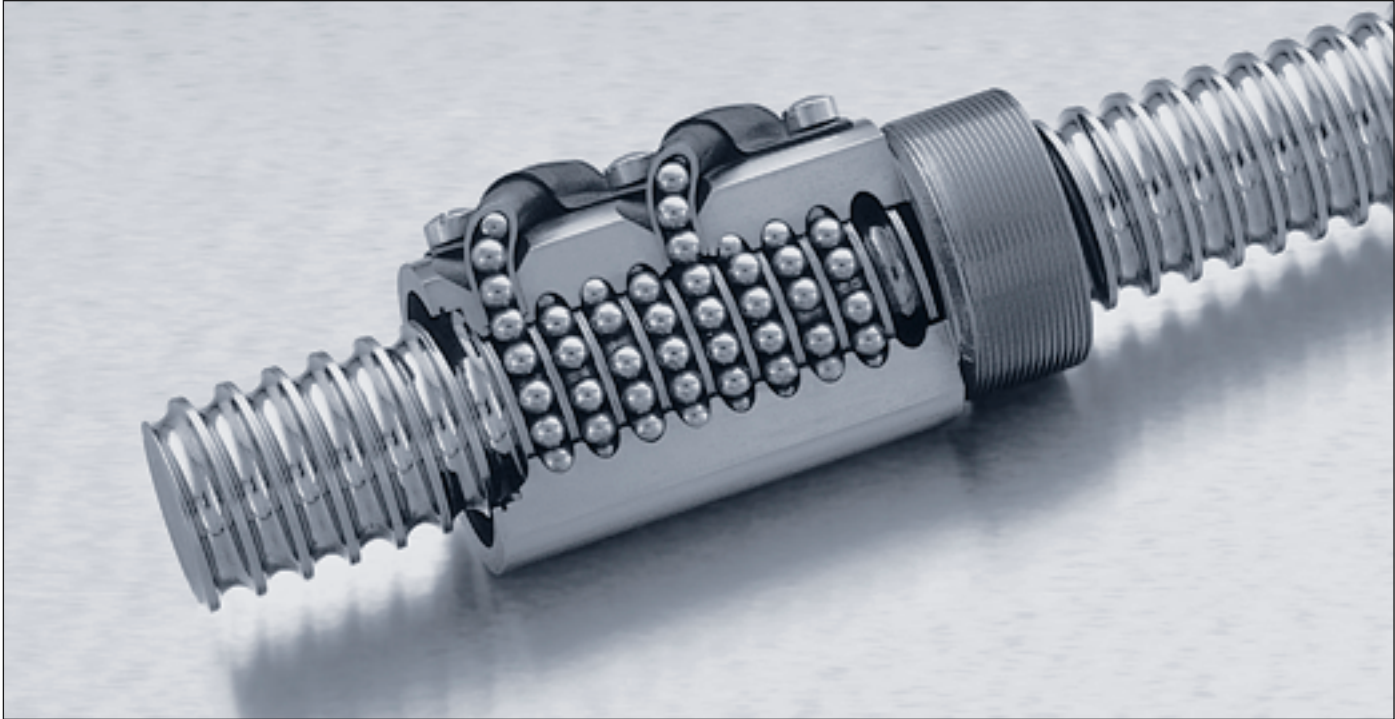

Each Thomson ball screw assembly consists of a screw (the inner race) with a precision helical groove, a nut (the outer race) with an internal groove, and precision steel balls that recirculate in the grooves between the screw and nut. This anti-friction design converts torque to thrust, or vice versa. As the screw or nut rotates, its mating component translates linearly.

### The Thomson Advantages

Ball screws are not all alike. Differences in material, design, and manufacturing, coupled with extensive inspection and applications support, are all factors that affect the performance and extend the life of your ball screw. That's why it's important to select your ball screw — and ball screw supplier — very carefully.

#### Design

The Thomson thread form, "the Gothic Arch," (see Figures 1 and 2 on page 89) maintains tighter contact angle control than other thread forms. This rigid control of contact angle results in:

- Low contact stresses which provide high load capacity and maximum predictable life
- Improved stiffness
- Minimal backlash accumulation in non-preloaded assemblies
- Long-lasting preload and consistent stiffness

Thomson ball screws also employ a durable external return ball recirculation system and a selection of specially designed replaceable seal/wiper designs that provide superior lubricant retention, while keeping out harmful contaminants.

#### Performance

Ball screw assemblies from Danaher Motion provide performance advantages that other ball screws just can't match. These include:

- **Higher Dynamic Load Ratings**

While other companies manufacture ball screws to conform to theoretically calculated standards, our products reflect empirically derived performance and use values which result in, size for size, the highest dynamic load rating in the industry.

- **Longer Service Life**

Compared to competitive ball screws, our assemblies provide longer service life. This increased life is determined by the ratio of the Thomson dynamic load rating versus competitive rating raised to the third power.

**Example:**

$$\text{Life} = (C/F)^3 \times 10^6 \text{ in.}$$

	Competitor	Thomson
Maximum Capacity	4,141 lb.	5,360 lb.
Relative Capacity	1.0	1.29 vs. Competitor
Relative Life At Capacity Full Load	1.0 x 10 <sup>6</sup> in.	2.1 x 10 <sup>6</sup> in. vs. Base Line for Competitor (5,360 ÷ 4,141) <sup>3</sup> x 10 <sup>6</sup>

The Thomson ball screw assembly provides 210% life expectancy or twice the life of the competitor's assembly in this example.

INCH

## Manufacturing

Danaher Motion maintains the most modern and complete ball screw manufacturing facility in the industry. In-house manufacturing capabilities include our proprietary heat treating and plating processes. Expert manufacturing, using the most modern equipment available, provides ball screws that set the standards for performance, precision, and travel life. Our ball screws feature leads as accurate as .0002 in./ft. and fluctuation (wobble) resolution as low as .0001 in. Predictable travel life is made possible by maintaining tight quality and process control measures.

## Inspection

What some suppliers may consider to be complex or elaborate inspection methods are routine in-house procedures at Danaher Motion. Tests for structural and metallurgical integrity include magnetic particle, dye penetrant, and eddy current inspections. Laser interferometry is used for measuring lead accuracy and fluctuation. Our fully equipped engineering laboratory performs qualification testing for mechanical performance, environmental effects, and structural integrity. Your ball screw is inspected every step of the way to ensure top quality and performance. The result, Thomson ball screws perform the way you expect them to perform — no surprises, no problems.

## Materials

The materials used to manufacture ball screws are critical to their performance. Our in-house metallurgists control and verify that the materials used are of the highest quality. They can also select and recommend materials best suited to your particular application.

## Applications Support

While manufacturing top quality ball screws is a key ingredient to customer satisfaction, the true measure of a ball screw supplier is gauged by the level of applications engineering, service, and support provided. Working with us is like having your own staff of ball screw design engineers able to address application concerns and recommend solutions. The company's sales and engineering personnel have more ball screw expertise than any other group in the industry. They are skilled at evaluating your requirements and designing assemblies that fit your needs.

## Customer Service

Danaher Motion customer service is flexible in developing delivery schedules for your production requirements. District managers are linear motion experts, always available for technical support and application proposals. Conveniently located in your area, they are an important interface between you and Danaher Motion.

We have the largest and most skilled network of industrial linear motion distributors, with over 1800 locations worldwide. Each person in this network is dedicated to supplying you with the right answers to your ball screw questions.

## Non-Preloaded

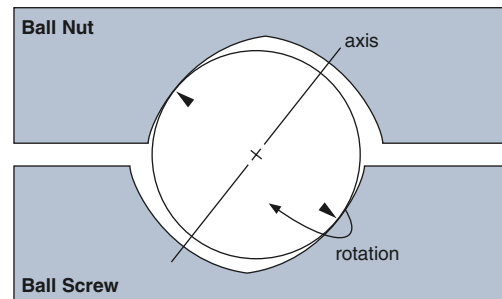

Figure 1

## Single Nut Preloaded

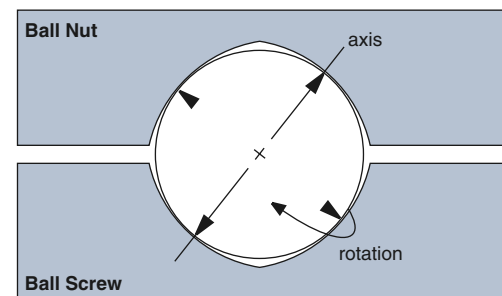

Figure 2

## Skip Lead

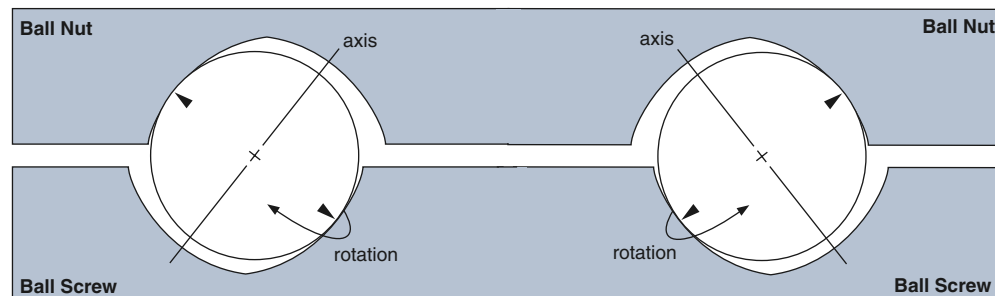
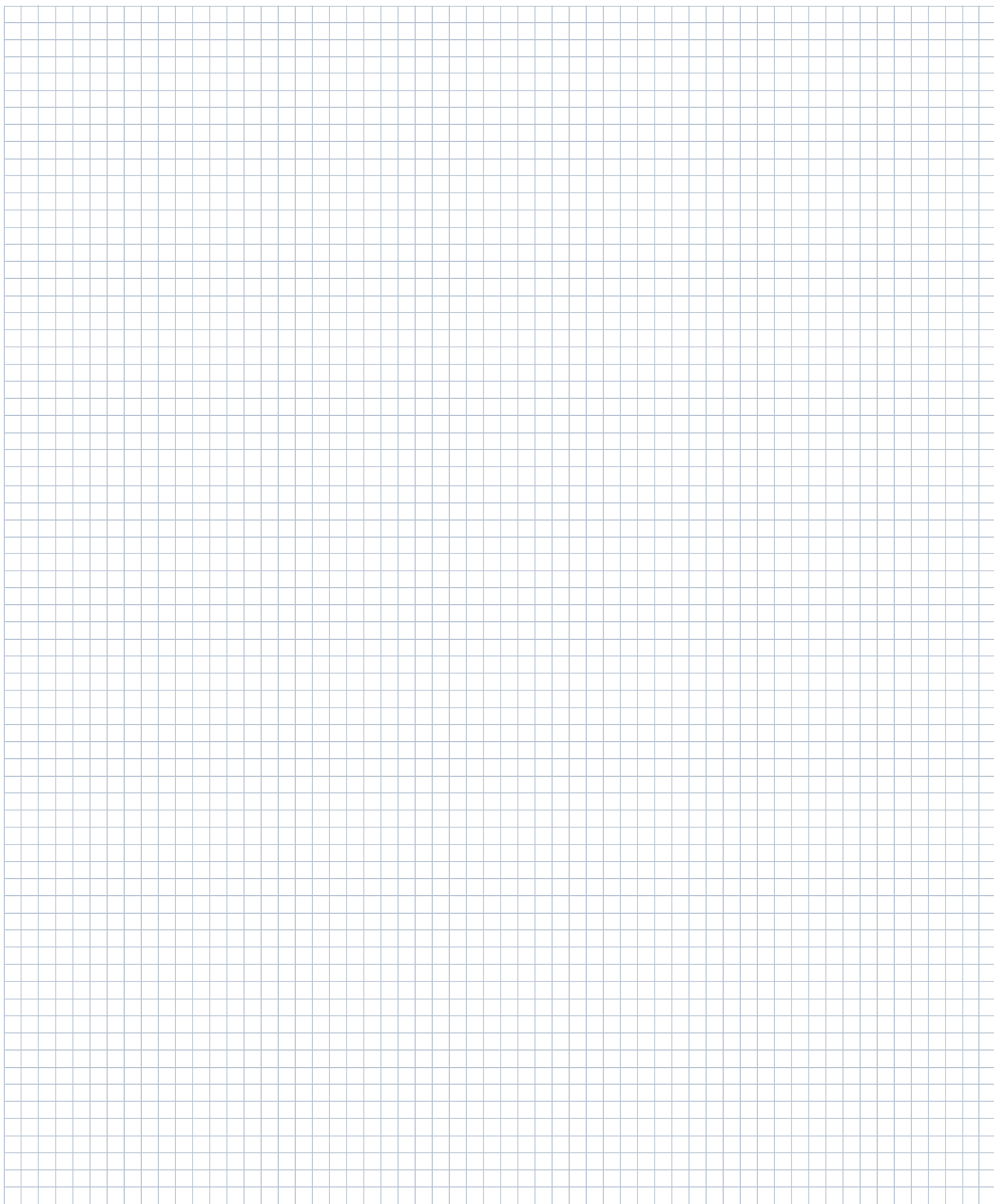

Figure 3

**NOTES:**



INCH

## Precision Plus - Inch

### Product Specifications

- Lead Accuracies
  - .0005 in./ft. standard
  - .0002 in./ft. accuracy available
- Backlash zero

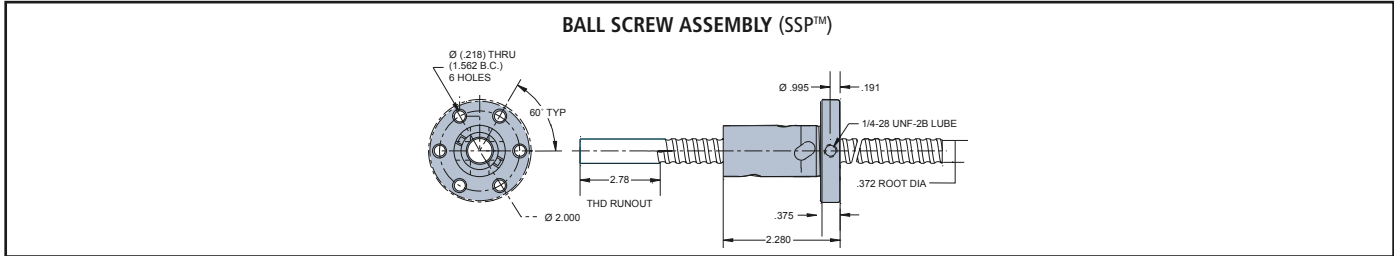

Ball Circle Diameter (size)	Lead (in.)	General Description	Assembly Part Number	Dynamic Load (lb <sub>f</sub> )	Max. Static Load (lb <sub>f</sub> )	Weight (lb)	Flange Part Number	Wiper Kit Part Number	End Block Part Number
.500	.200	RH, Preload (42 in. OAL)	7829724	416	1500	3.5	Integral	Integral	7828282

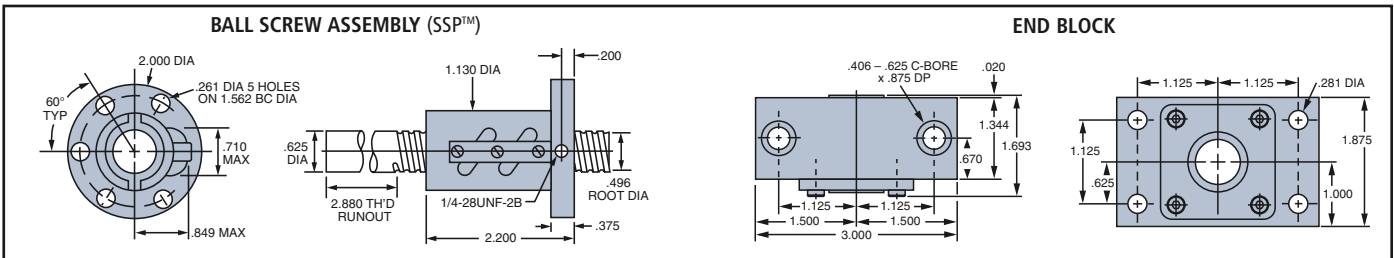

Ball Circle Diameter (size)	Lead (in.)	General Description	Assembly Part Number	Dynamic Load (lb <sub>f</sub> )	Max. Static Load (lb <sub>f</sub> )	Weight (lb)	Flange Part Number	Wiper Kit Part Number	End Block Part Number
.631	.200	RH, Preload (42 in. OAL)	7820396	440	2,110	3.61	Integral	Integral	7824154

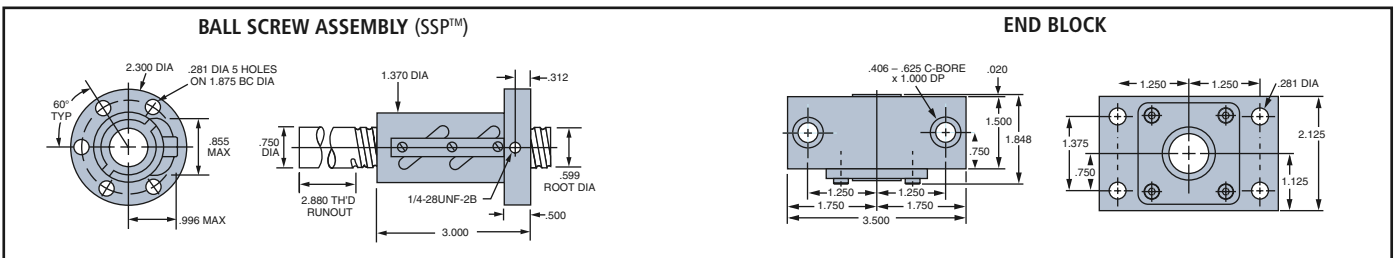

Ball Circle Diameter (size)	Lead (in.)	General Description	Assembly Part Number	Dynamic Load (lb <sub>f</sub> )	Max. Static Load (lb <sub>f</sub> )	Weight (lb)	Flange Part Number	Wiper Kit Part Number	End Block Part Number
.750	.200	RH, Preload (42 in. OAL)	5700974	1,473	9,916	5.37	Integral	Integral	7824155



Precision Plus - Inch

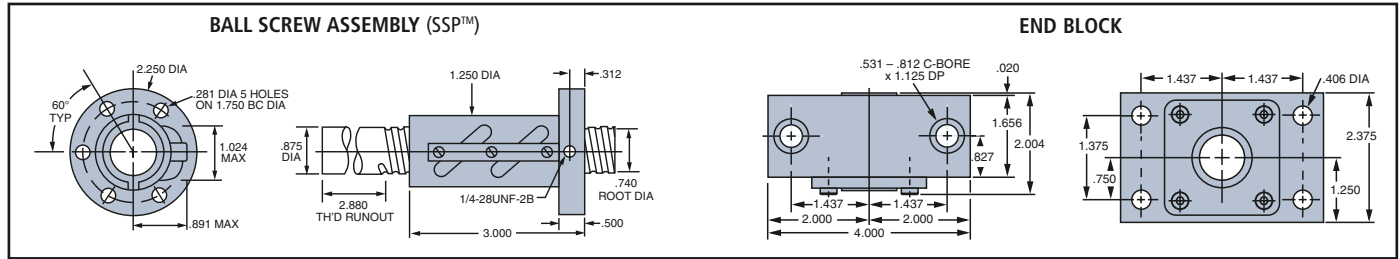

Ball Circle Diameter (size)	Lead (in.)	General Description	Assembly Part Number	Dynamic Load (lb <sub>f</sub> )	Max. Static Load (lb <sub>f</sub> )	Weight (lb)	Flange Part Number	Wiper Kit Part Number	End Block Part Number
.75	.200	RH, Preload (60 in. OAL)	7820397	1,375	10,780	9.61	Integral	Integral	7824156

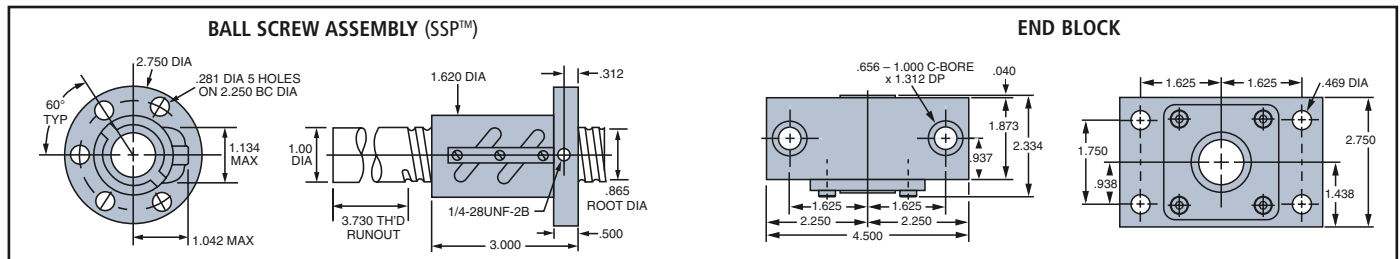

Ball Circle Diameter (size)	Lead (in.)	General Description	Assembly Part Number	Dynamic Load (lb <sub>f</sub> )	Max. Static Load (lb <sub>f</sub> )	Weight (lb)	Flange Part Number	Wiper Kit Part Number	End Block Part Number
1.000	.200	RH Preload (72 in. OAL)	5700975	1,565	13,073	15.24	Integral	Integral	7824157

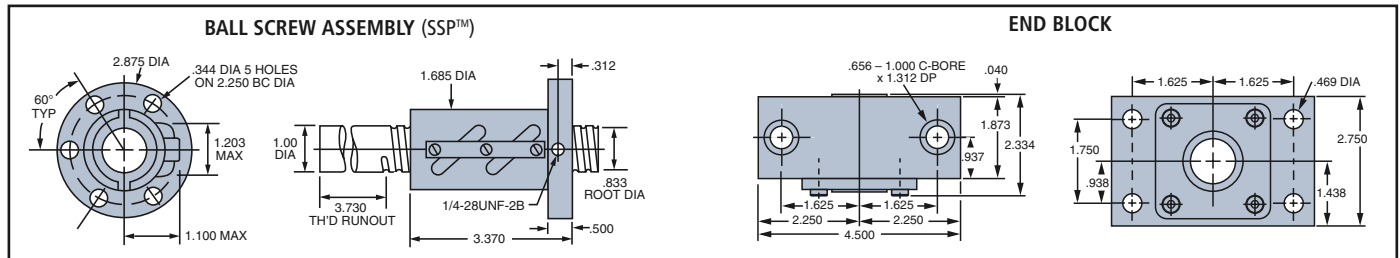

Ball Circle Diameter (size)	Lead (in.)	General Description	Assembly Part Number	Dynamic Load (lb <sub>f</sub> )	Max. Static Load (lb <sub>f</sub> )	Weight (lb)	Flange Part Number	Wiper Kit Part Number	End Block Part Number
1.000	.250	RH, Preload (72 in. OAL)	7820477	2,285	15,815	15.36	Integral	Integral	7824157

General Description Legend

C1	One Circuit	NP	Non-preloaded Ball Nut	Rnd	Round
C2	Two Circuits	OAL	Overall Length	Sq.	Square
KW	Keyway	Preload	Preloaded Ball Nut	SS	Stainless Steel
LH	Left Hand	RH	Right Hand	v	Valued Priced

INCH

Precision Plus - Inch

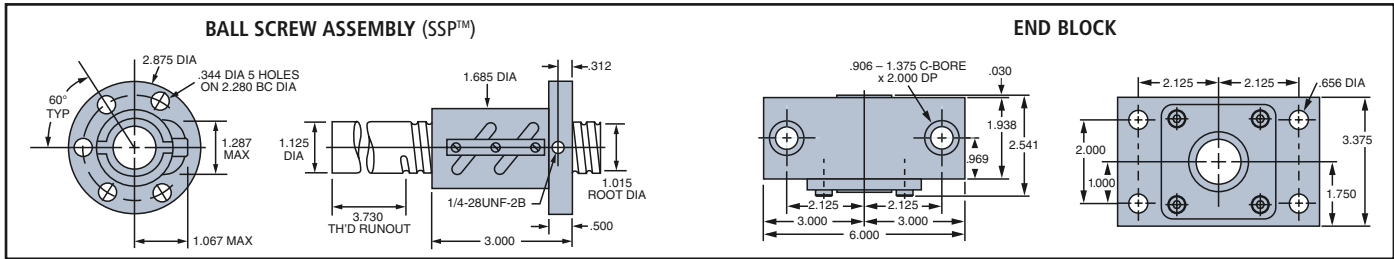

Ball Circle Diameter (size)	Lead (in.)	General Description	Assembly Part Number	Dynamic Load (lb <sub>f</sub> )	Max. Static Load (lb <sub>f</sub> )	Weight (lb)	Flange Part Number	Wiper Kit Part Number	End Block Part Number
1.150	.200	RH, Preload (72 in. OAL)	5700976	1,680	14,886	20.35	Integral	Integral	7824158

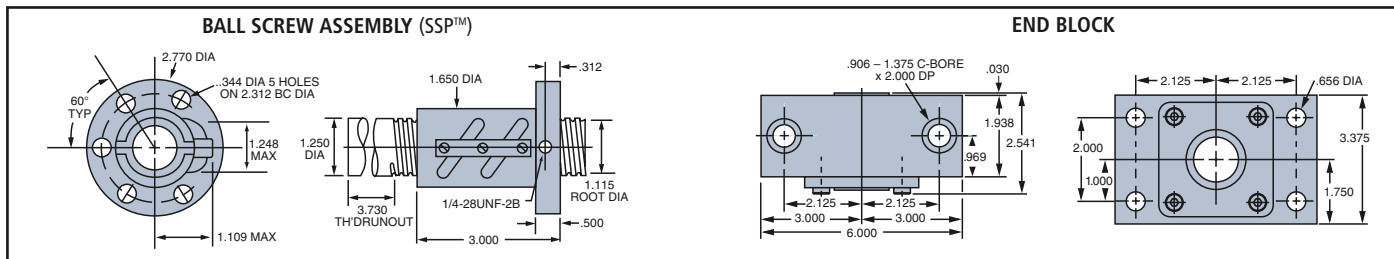

Ball Circle Diameter (size)	Lead (in.)	General Description	Assembly Part Number	Dynamic Load (lb <sub>f</sub> )	Max. Static Load (lb <sub>f</sub> )	Weight (lb)	Flange Part Number	Wiper Kit Part Number	End Block Part Number
1.250	.200	RH, Preload (72 in. OAL)	5700977	1,800	16,625	23.68	Integral	Integral	7824158
		LH, Preload (72 in. OAL)	7820830	1,800	16,625	23.68	Integral	Integral	7824158

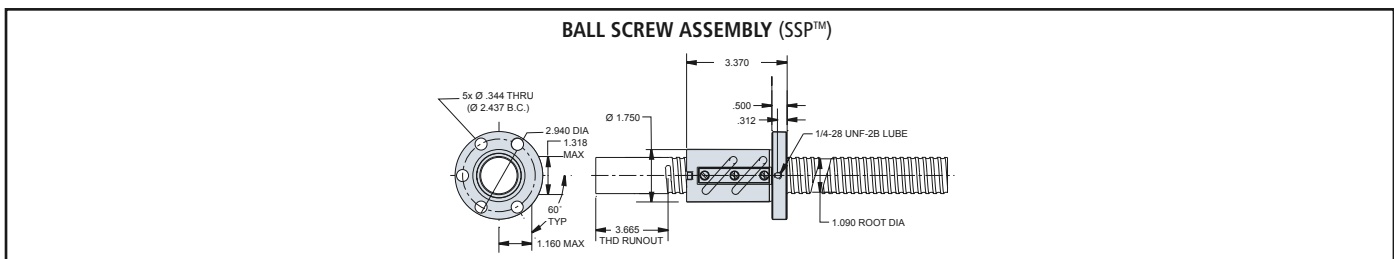

Ball Circle Diameter (size)	Lead (in.)	General Description	Assembly Part Number	Dynamic Load (lb <sub>f</sub> )	Max. Static Load (lb <sub>f</sub> )	Weight (lb)	Flange Part Number	Wiper Kit Part Number	End Block Part Number
1.250	.250	RH, Preload (72 in. OAL)	7829725	2624	19,200	23.68	Integral	Integral	7824158

Precision Plus - Inch

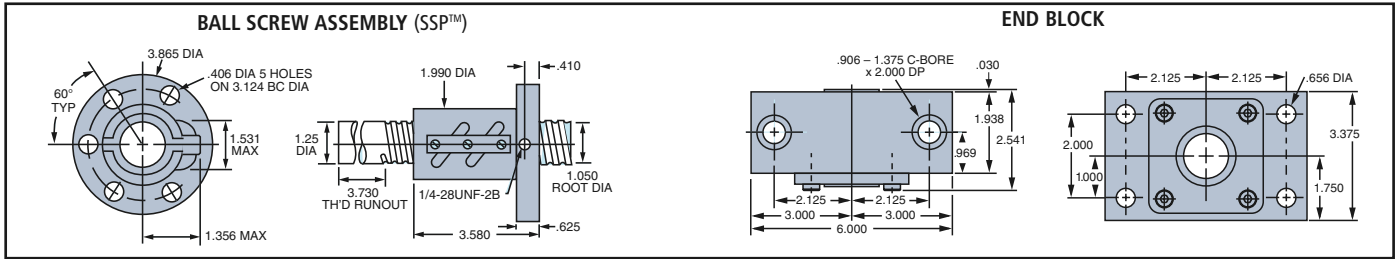

Ball Circle Diameter (size)	Lead (in.)	General Description	Assembly Part Number	Dynamic Load (lb <sub>f</sub> )	Max. Static Load (lb <sub>f</sub> )	Weight (lb)	Flange Part Number	Wiper Kit Part Number	End Block Part Number
1.250	.500	RH, Preload (96 in. OAL)	7820399	1,765	11,080	25.61	Integral	Integral	7824158

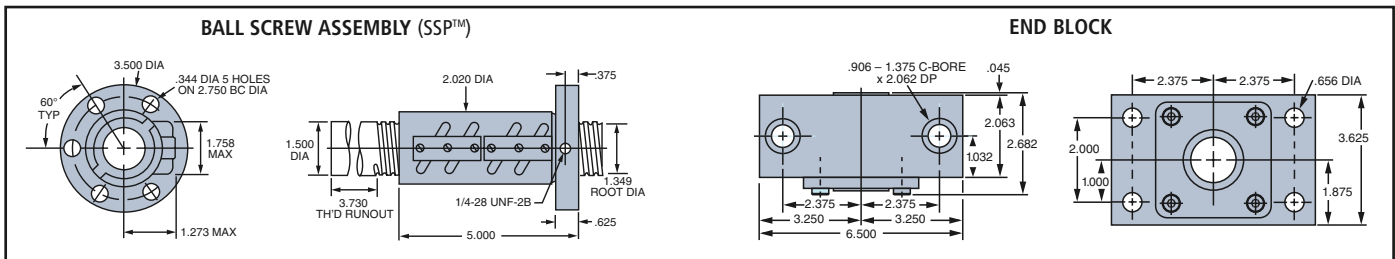

Ball Circle Diameter (size)	Lead (in.)	General Description	Assembly Part Number	Dynamic Load (lb <sub>f</sub> )	Max. Static Load (lb <sub>f</sub> )	Weight (lb)	Flange Part Number	Wiper Kit Part Number	End Block Part Number
1.500	.200	RH, Preload (120 in. OAL)	7820375	4,745	45,073	45.84	Integral	Integral	7824159

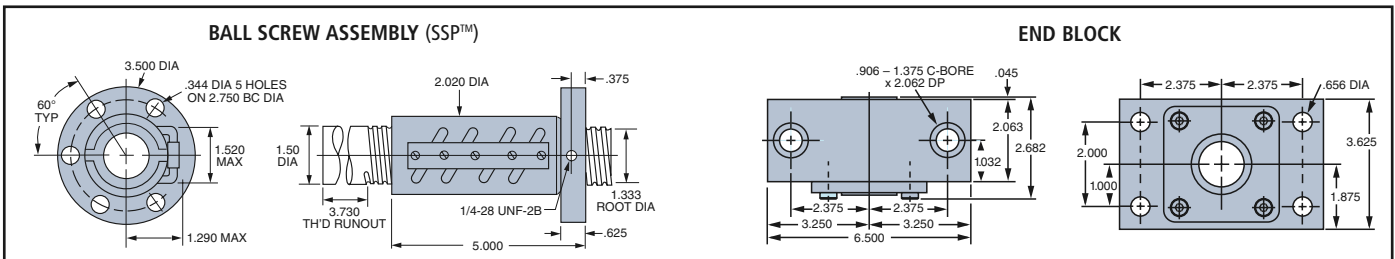

Ball Circle Diameter (size)	Lead (in.)	General Description	Assembly Part Number	Dynamic Load (lb <sub>f</sub> )	Max. Static Load (lb <sub>f</sub> )	Weight (lb)	Flange Part Number	Wiper Kit Part Number	End Block Part Number
1.500	.250	RH, Preload (120 in. OAL)	7820965	4,250	27,250	45.83	Integral	Integral	7824159

INCH

Precision Plus - Inch

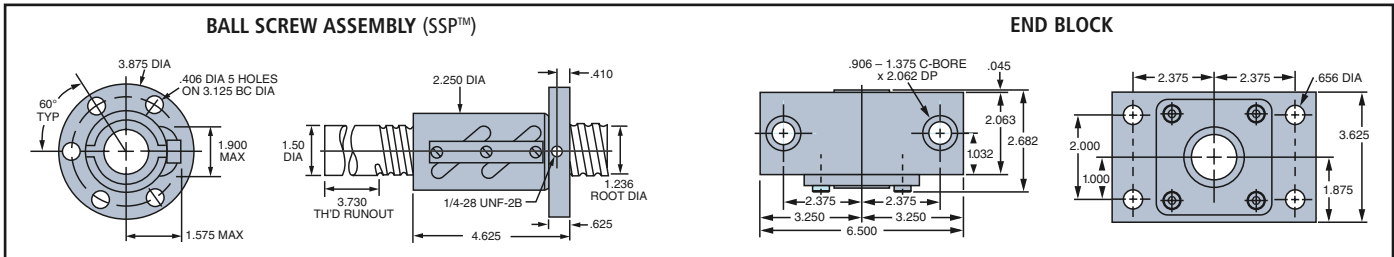

Ball Circle Diameter (size)	Lead (in.)	General Description	Assembly Part Number	Dynamic Load (lb <sub>f</sub> )	Max. Static Load (lb <sub>f</sub> )	Weight (lb)	Flange Part Number	Wiper Kit Part Number	End Block Part Number
1.500	.500	RH, Preload (120 in. OAL)	7820401	5,075	35,770	46.05	Integral	Integral	7824159

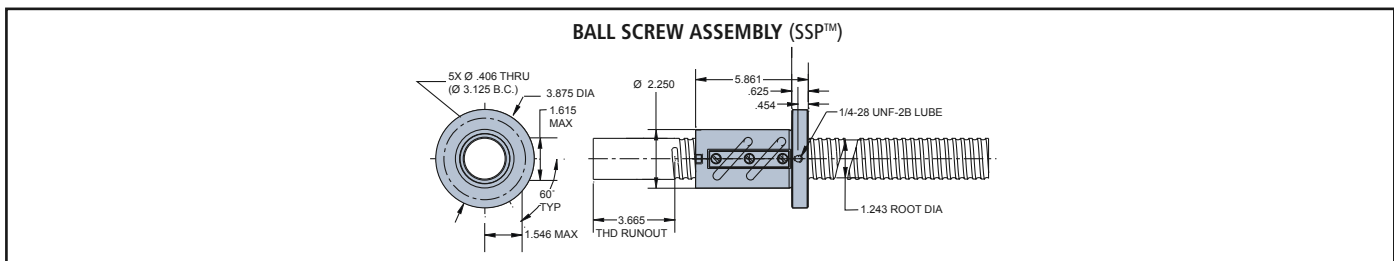

Ball Circle Diameter (size)	Lead (in.)	General Description	Assembly Part Number	Dynamic Load (lb <sub>f</sub> )	Max. Static Load (lb <sub>f</sub> )	Weight (lb)	Flange Part Number	Wiper Kit Part Number	End Block Part Number
1.500	1.000	RH, Preload (96 in OAL)	7829726	3,712	21,500	46.05	Integral	Integral	7824159

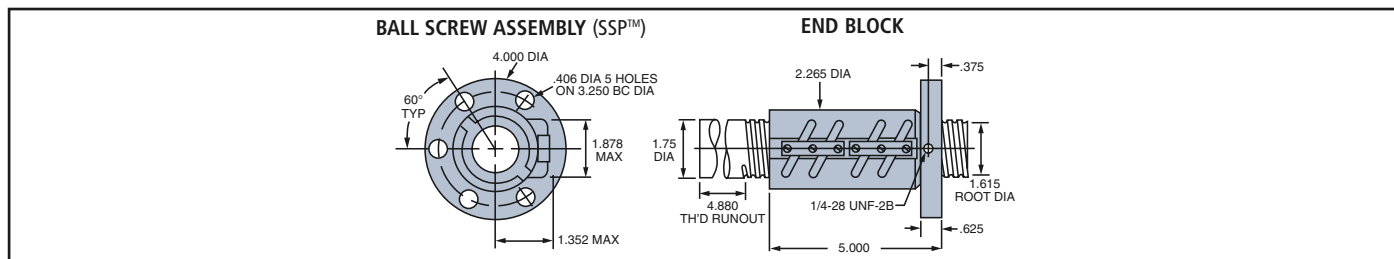

Ball Circle Diameter (size)	Lead (in.)	General Description	Assembly Part Number	Dynamic Load (lb <sub>f</sub> )	Max. Static Load (lb <sub>f</sub> )	Weight (lb)	Flange Part Number	Wiper Kit Part Number	End Block Part Number
1.750	.200	RH, Preload (96 in OAL)	5700979	4,464	47,446	64.08	Integral	Integral	7829554

Precision Plus - Inch

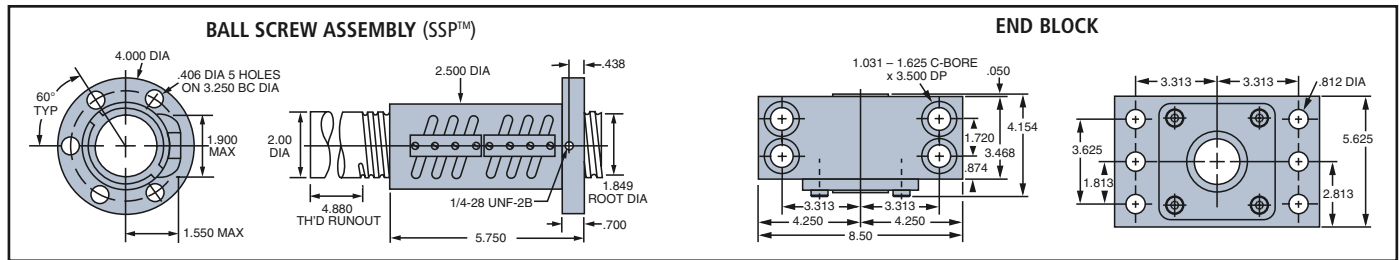

Ball Circle Diameter (size)	Lead (in.)	General Description	Assembly Part Number	Dynamic Load (lb <sub>f</sub> )	Max. Static Load (lb <sub>f</sub> )	Weight (lb)	Flange Part Number	Wiper Kit Part Number	End Block Part Number
2.000	.200	RH, Preload (120 in. OAL)	7820402	6,181	65,903	82.44	Integral	Integral	7824160

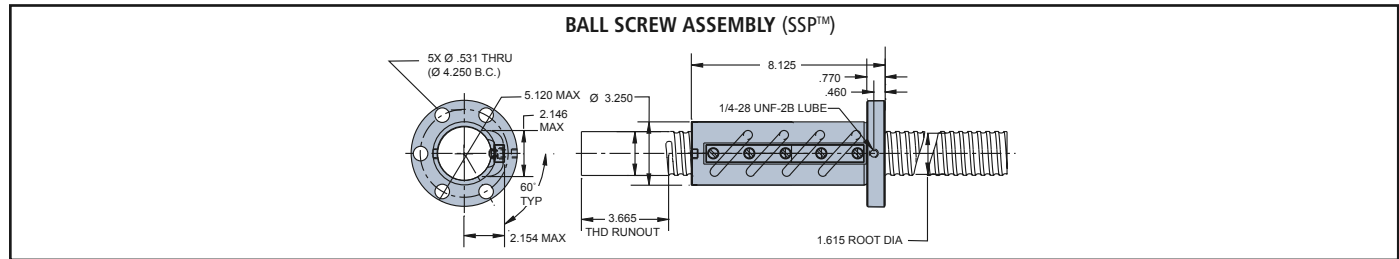

Ball Circle Diameter (size)	Lead (in.)	General Description	Assembly Part Number	Dynamic Load (lb <sub>f</sub> )	Max. Static Load (lb <sub>f</sub> )	Weight (lb)	Flange Part Number	Wiper Kit Part Number	End Block Part Number
2.000	.500	RH, Preload (96 in. OAL)	7829727	20,500	106,000	82.44	Integral	Integral	7824160

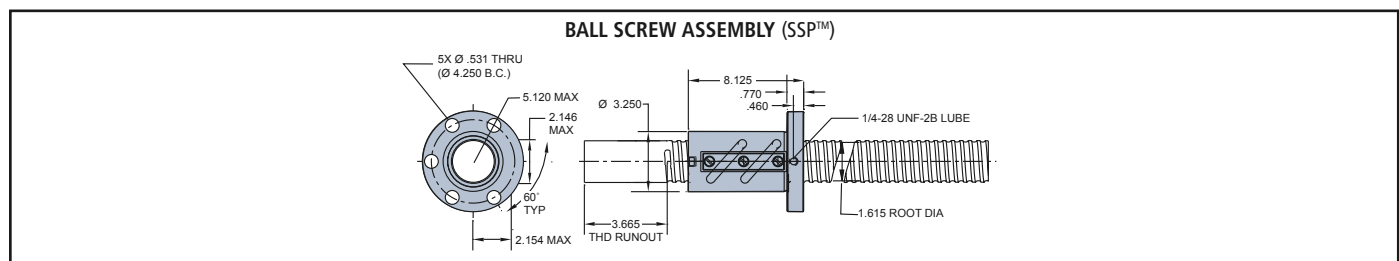

Ball Circle Diameter (size)	Lead (in.)	General Description	Assembly Part Number	Dynamic Load (lb <sub>f</sub> )	Max. Static Load (lb <sub>f</sub> )	Weight (lb)	Flange Part Number	Wiper Kit Part Number	End Block Part Number
2.000	1.000	RH, Preload (96 in OAL)	7829728	13075	55,000	82.44	Integral	Integral	7824160

General Description Legend

C1	One Circuit	NP	Non-preloaded Ball Nut	Rnd	Round
C2	Two Circuits	OAL	Overall Length	Sq.	Square
KW	Keyway	Preload	Preloaded Ball Nut	SS	Stainless Steel
LH	Left Hand	RH	Right Hand	v	Valued Priced

INCH

Precision Plus - Inch

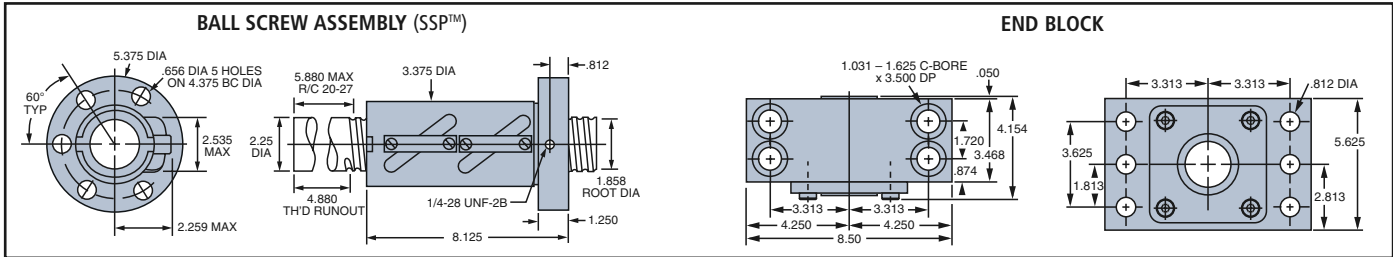

Ball Circle Diameter (size)	Lead (in.)	General Description	Assembly Part Number	Dynamic Load (lb <sub>f</sub> )	Max. Static Load (lb <sub>f</sub> )	Weight (lb)	Flange Part Number	Wiper Kit Part Number	End Block Part Number
2.250	.500	RH, Preload (120 in. OAL)	7820484	20,160	108,325	100.87	Integral	Integral	7824160

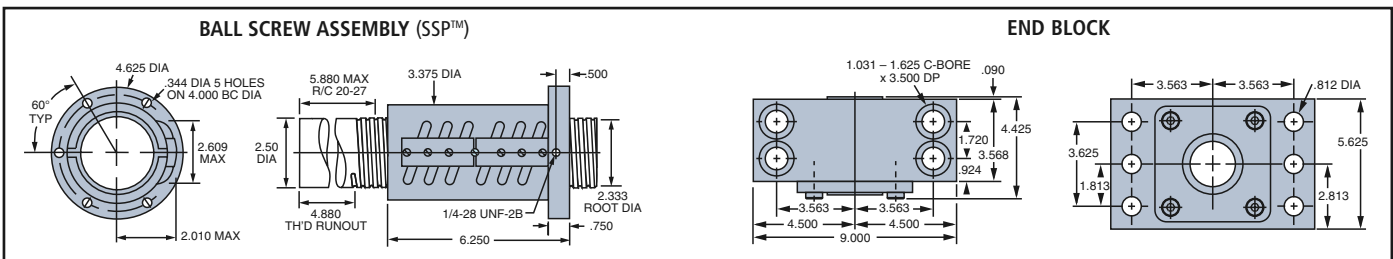

Ball Circle Diameter (size)	Lead (in.)	General Description	Assembly Part Number	Dynamic Load (lb <sub>f</sub> )	Max. Static Load (lb <sub>f</sub> )	Weight (lb)	Flange Part Number	Wiper Kit Part Number	End Block Part Number
2.500	.250	RH, Preload (120 in. OAL)	7820483	8,945	93,165	133.50	Integral	Integral	7824161

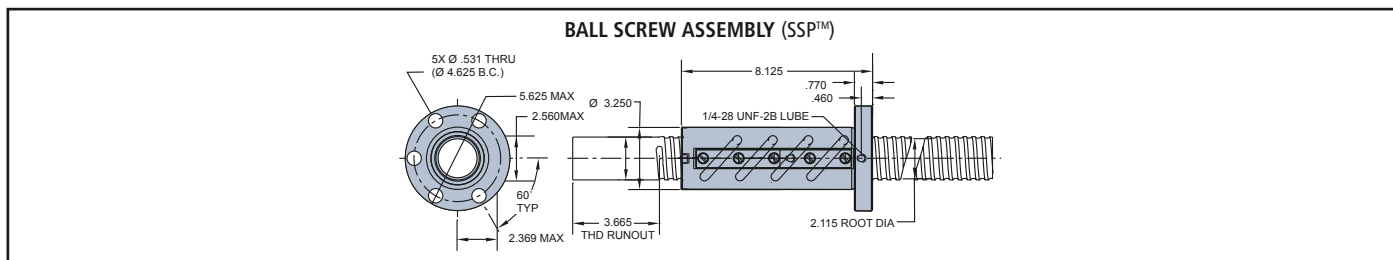

Ball Circle Diameter (size)	Lead (in.)	General Description	Assembly Part Number	Dynamic Load (lb <sub>f</sub> )	Max. Static Load (lb <sub>f</sub> )	Weight (lb)	Flange Part Number	Wiper Kit Part Number	End Block Part Number
2.500	.500	RH, Preload (96 in. OAL)	7829729	24000	140000	133.50	Integral	Integral	7824161

## Quick Mount Bearing Support Blocks - Inch

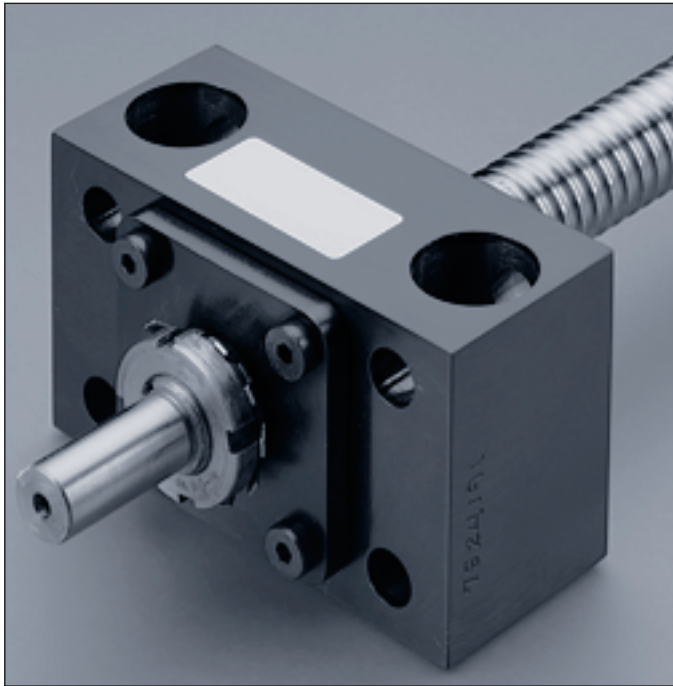

### A unitized package for simple mounting of Thomson Precision ball screw assemblies.

- Rugged steel construction
- Low profile, compact design
- Foot or face mounting Standard series
- Foot mounting V-Series
- A pre-assembled package ready for installation
- High capacity angular contact bearings arranged in a back-to-back (DB) configuration for high stiffness
- Installation accessories (locknut and washer) included for complete assembly
- design dimensions fit a standard Type III machined end for ball screws. See page 55.
- The Quick Mount will provide a "simple" bearing support for purposes of critical speed and column strength calculations
- Available off-the-shelf for your machine building convenience

10 Pillow Block configurations have been designed to accommodate the following ball screw sizes.

Dia. x Lead (in)	Standard
.500 x .200	7828282
.500 X .500	7828282
.631 x .200	7824154
.631 x 1.00	7824154
.750 x .200	7824155
.750 x .500	7824155
.875 x .200	7824156
1.000 x .200	7824157
1.000 x .250	7824157
1.000 x .500	7824157
1.000 x 1.00	7824157
1.150 x .200	7824158
1.171 x .413	7824157
1.250 x .200 & .250 & .500	7824158
1.500 x .200	7824159
1.500 x .250	7824159
1.500 x .473	7824158
1.500 x .500	7824159
1.500 x 1.00	7824158
1.500 x 1.875	7824159
1.750 X .200	7829554
2.000 x .200 & .500 & 1.000	7824160
2.250 x .500	7824160
2.250 x 1.00	7824160
2.500 x .250	7824161
2.500 x .500	7824161

INCH

## Quick Mount Inch Bearing Support Blocks

### Product Dimensions and Specifications

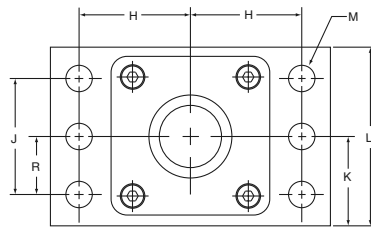
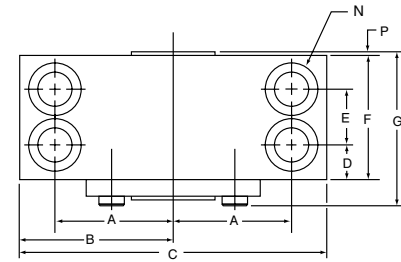
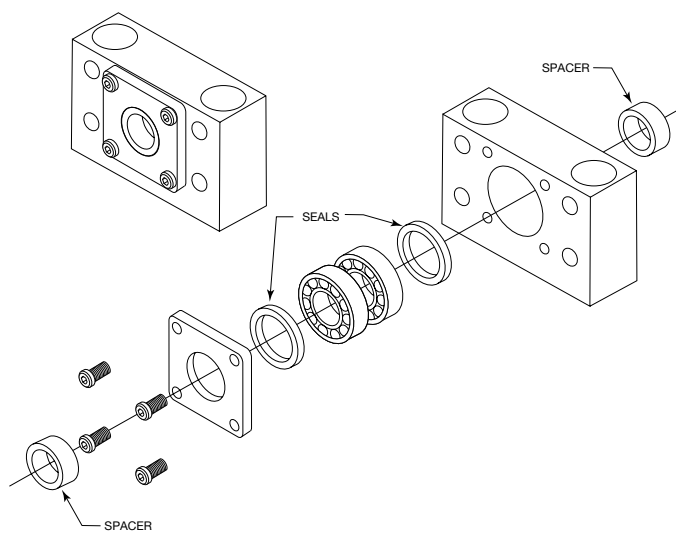

Standard	A	B	C	D	E	F	G	H	J	K	L	M	N	P	R	Locknut
7828282	1.00	1.38	2.75	0.62	—	1.18	1.37	1.00	1.38	1.00	2.00	4 Holes .28 Dia.	Dia. .314 thru Dia. .50 C-Bore x .56 DP 2 Holes	—	0.69	5/16-24
7824154	1.125	1.500	3.000	.670	—	1.344	1.693	1.125	1.125	1.000	1.875	4 Holes .281 Dia.	Dia. .406 thru Dia. .625 C-Bore x .875 DP 2 Holes	.020	.625	N-01
7824155	1.250	1.750	3.500	.750	—	1.500	1.848	1.250	1.375	1.125	2.125	4 Holes .281 Dia.	Dia. .406 thru Dia. .625 C-Bore x 1.000 DP 2 Holes	.020	.750	N-02
7824156	1.437	2.000	4.000	.828	—	1.656	2.004	1.437	1.375	1.250	2.375	4 Holes .406 Dia.	Dia. .531 thru Dia. .812 C-Bore x 1.125 DP 2 Holes	.020	.750	N-03
7824157	1.625	2.250	4.500	.937	—	1.873	2.334	1.625	1.750	1.438	2.750	4 Holes .469 Dia.	Dia. .656 thru Dia. 1.000 C-Bore x 1.312 DP 2 Holes	.040	.938	N-04
7824158	2.125	3.000	6.000	.969	—	1.938	2.541	2.125	2.000	1.750	3.375	4 Holes .656 Dia.	Dia. .906 thru Dia. 1.375 C-Bore x 2.000 DP 2 Holes	.030	1.000	N-05
7824159	2.375	3.250	6.500	1.032	—	2.063	2.682	2.375	2.000	1.875	3.625	4 Holes .656 Dia.	Dia. .906 thru Dia. 1.375 C-Bore x 2.062 DP 2 Holes	.045	1.000	N-06
7829554	2.937	3.750	7.500	0.758	1.634	3.150	3.785	2.937	3.000	2.250	4.250	4 Holes .6 Dia.	Dia. .906 thru Dia. 1.375 C-Bore x 2.25 DP 4 Holes	.050	1.500	N-08
7824160	3.313	4.250	8.500	.874	1.720	3.468	4.154	3.313	3.625	2.813	5.625	6 Holes .812 Dia.	Dia. 1.031 thru Dia. 1.625 C-Bore x 3.500 DP 4 Holes	.050	1.813	N-09
7824161	3.563	4.500	9.000	.924	1.720	3.568	4.425	3.563	3.625	2.813	5.625	6 Holes .812 Dia.	Dia. 1.031 thru Dia. 1.625 C-Bore x 3.500 DP 4 Holes	.090	1.813	N-10



## Metric Ball Screws



- Precision
- FineLine
- Precision Plus

## Outstanding Precision at an Affordable Price.

Our patented, German-engineered Precision Screw Forming (PSF) Technology has created a higher performing Thomson ball screw, combining outstanding precision – traditionally associated with ground screws – with the manufacturing efficiency of rolled processes. The result is an affordable ball screw with highest precision and outstanding performance. Thomson FineLine ball screws are equal in accuracy and performance to ground screws of the same accuracy class, but with harder grain structures, lower cost, and short manufacturing lead times. PSF Technology consistently produces screws with accuracies ranging up to 24mm/300mm (0.001 in/foot). Available from over 1800 distributors worldwide.

## Product Selection

Performance Ranges	Precision Class				
	T5 - 23um / 300mm (.001 in/ft) T7 - 52um / 300mm (.002 in/ft)		P5 - 23um / 300mm (.0009 in/ft)		P3 - 12um / 300mm (.0005 in/ft) (P1 - 4.8um / 300mm available) (.0002 in/ft)
Series	Precision ZG (preloaded/ non-preloaded)	Precision FS (preloaded/ non-preloaded)	FineLine FK (preloaded/ non-preloaded)	FineLine FH (preloaded/ non-preloaded)	Precision Plus FL
Dia. x Lead	12 x 4 to 80 x 10	12 x 5 to 40 x 40	16 x 5 to 80 x 10	20 x 20 to 63 x 20	16 x 5 to 63 x 20
Backlash	zero to 0.18mm	zero to 0.18mm	zero to 0.18mm	zero to 0.18mm	zero
Dynamic Load	up to 121.9kN	up to 29.8kN	up to 121.9kN	up to 103.1kN	up to 98.4kN
Max. Static Load	up to 375kN	up to 45.4kN	up to 374.9kN	up to 270.8kN	up to 177.5kN
Catalog Pages	118	120	129	129	135

## Efficiency & Torque

The ball screw assembly's performance in converting between linear motion and rotational torque is its efficiency,  $\eta$ . Efficiency depends primarily on geometrical data, though various operating influences can swing actual efficiency by  $\pm 5\%$  from the calculated. As such,

to account for operational influences such as speed, temperature, lubricant, etc., approximately 5% of the theoretical efficiency should be deducted. Furthermore, if the ratio of load (F) to dynamic load rating (C<sub>am</sub>) is below 0.5, then an additional reduction in relation to the load

factor is to be applied (see table below for f<sub>L</sub>). The efficiency calculated on this basis applies for the ball screw including lubrication but without considering wipers or shaft support. If an improvement in efficiency is required, please contact our engineering department.

### Efficiency: Rotary to Linear

The theoretical efficiency ( $\eta$ ), when converting torque into linear motion is:

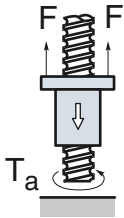

$$\eta = \frac{\tan \varphi}{\tan (\varphi + \rho'')} \text{ with } \tan \varphi = \frac{P_{ho}}{d_o \times \pi}$$

### Torque: Rotary to Linear

When converting torque into linear motion, the necessary drive torque is:

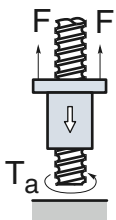

$$T_a = \frac{F \times P_{ho}}{2 \times \pi \times \eta_p}$$

### Efficiency: Linear to Rotary

The theoretical efficiency ( $\eta'$ ), when converting linear motion into torque is:

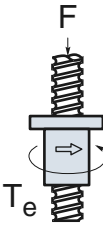

$$\eta' = \frac{\tan (\varphi + \rho'')}{\tan \varphi} \text{ with } \tan \varphi = \frac{P_{ho}}{d_o \times \pi}$$

### Torque: Linear to Rotary

When converting linear motion into torque, the resulting output torque is:

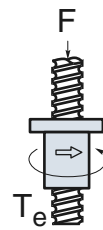

$$T_e = \frac{F \times P_{ho} \times \eta'_p}{2 \times \pi}$$

### Practical Efficiency

$$\eta_p = \eta \times .95 f_L$$

#### Parameters:

$\rho''$	=	friction angle (0.23° for P-class tolerances, 0.34° for T-class tolerances)
$\varphi$	=	lead angle
$P_{ho}, d_o$	=	lead & diameter (see product specifications)
F	=	axial load
C <sub>am</sub>	=	dynamic load rating
T <sub>a</sub>	=	drive torque
T <sub>e</sub>	=	output torque
f <sub>L</sub>	=	adjusted to load factor
$\eta, \eta'$	=	theoretical efficiency

### Load Adjustment Factors

$\frac{F}{C_{am}}$	Adjustment to load factor (f <sub>L</sub> )
0.5	1.00
0.4	0.99
0.3	0.98
0.2	0.97
0.1	0.96

For approximate torque based on 90% efficiency:

$$T_a = 0.177 \times F \times P_{ho}$$

$$T_e = .143 \times F \times P_{ho}$$

Example Parameters:  
 40 x 10 mm screw, P3 Class  
 F = 10 kN  
 C<sub>am</sub> = 53.9 kN

Rotary to Linear Application  
 The lead angle,  $\varphi$ , is found:

$$\tan \varphi = \frac{10}{40 \times \pi} = 0.08$$

$$\varphi = 4.55^\circ$$

P3 precision indicates friction angle of  $\rho'' = 0.23^\circ$   
 Thus, the theoretical efficiency is:

$$\eta = \frac{0.08}{\tan (4.55^\circ + 0.23^\circ)} = .96$$

The loading ratio is small, so a load adjustment factor is required:

$$\frac{F}{C_{am}} = \frac{10}{53.9} = 0.19$$

$$f_L = 0.97$$

Applying the load adjustment factor and 5% reduction gives practical efficiency of:

$$\eta_p = \eta \times .95 \times f_L$$

$$\eta_p = .96 \times .95 \times .97$$

$$\eta_p = .88 \pm 5\%$$

Torque required to drive the load is given by:

$$T_a = \frac{10,000 \text{ [N]} \times .010 \text{ [m]}}{2 \times \pi \times .88}$$

$$T_a = 18.1 \text{ [Nm]}$$

## Functional Life

The ball screw assembly's useful life will vary according to load and speed. Life is typically rated at 90% confidence, L10 (which represents time at which 90% of assemblies still perform).

Functional life should be determined by approximating equivalent rotational speed and loading force over typical performance cycles.

### Simple rotational speed profile

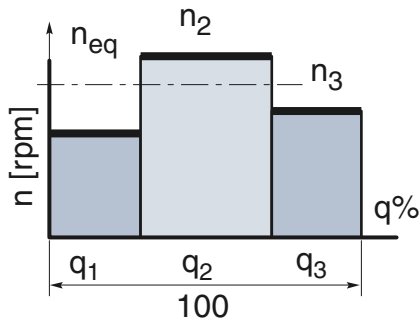

$$n_{eq} = \sum_{i=1}^n n_i \times \frac{q_i}{100} \text{ [min}^{-1}\text{]}$$

### Simple loading profile (1)

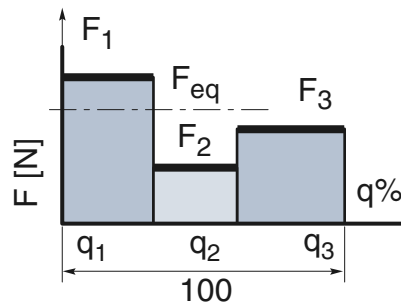

$$F_{eq} = \left( \sum_{i=1}^n F_i^3 \times \frac{n_i}{n_{eq}} \times \frac{q_i}{100} \right)^{1/3} \text{ [N]}$$

### Simple loading profile (2)

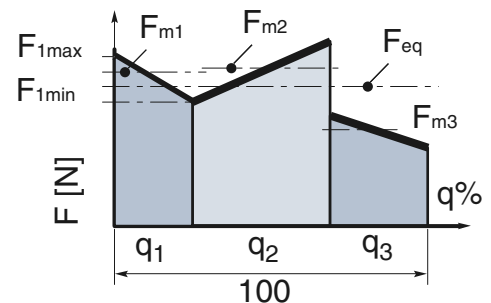

$$F_{eq} = \left( \sum_{i=1}^n F_{m_i}^3 \times \frac{n_i}{n_{eq}} \times \frac{q_i}{100} \right)^{1/3} \text{ [N]}$$

### Modified Life

$$L_{10} = \left[ \frac{C_{am}}{F_{eq}} \right]^3 \times 10^6 \text{ [rev]}$$

$$L_{h10} = \frac{L_{10}}{n_{eq} \times 60} \text{ [hours]}$$

### Parameters:

- $n_{eq}$  = equivalent rotational speed [rpm]
- $F_{eq}$  = equivalent load [N]
- $C_{am}$  = modified dynamic load rating [N] (see specification tables)

## Nut Loading

Axial loading (on nut or screw) is optimal for performance and life. For applications requiring radial loads, please contact us.

Axial Loading: optimal



Radial Loading: detrimental\*



\* Minimize radial loading to less than 5% of the axial load.

## Nut Mounting

Use the following guidelines to achieve optimal performance.

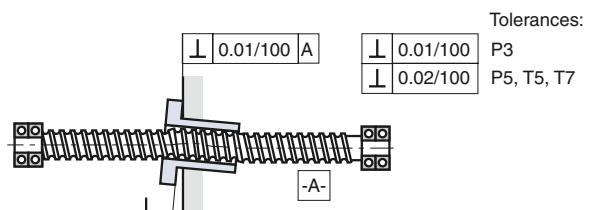
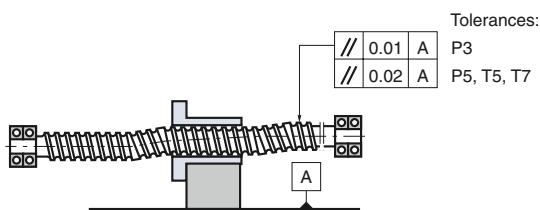

## Speed Limitations

### Critical Rotational Speed

Eccentricities in the screw will cause harmonic vibration at the critical rotational speed ( $n_{cr}$ ). Vibration speed and magnitude are determined by shaft diameter, unsupported length, type of bearing support, position of the ball nut in the

stroke, how the ball nut is mounted, the shaft or ball nut rpm, etc. (Shaft vibrations may also be caused by a bent screw or faulty installation alignment.) It is recommended that a 20% safety factor below critical harmonic speed.

$n_{cr}$  [rpm]

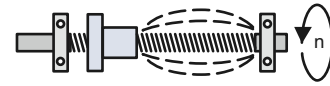

Critical harmonic speed:

$$n_{crp} = 1.2 \times 108 \times \frac{d}{l_{cr}^2} \text{ [rpm]}$$

Recommended maximum speed:

$$n_{crp} = 0.8 \times n_{cr} \times f_{cr} \text{ [rpm]}$$

Parameters:

$$d \approx \frac{d_0 + d_3}{2} \text{ [mm]}$$

$$d_3 \approx d_0 - D_w \text{ [mm]}$$

$$D_w = \text{Ball } \phi \text{ [mm]}$$

$$l_{cr} = \text{critical length [mm]}$$

$$f_{cr} = \text{mounting condition speed adjustment factor}$$

### Mounting Condition Effects

Fixed-Free

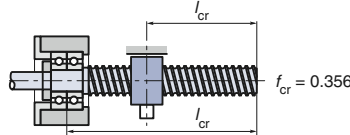

Simple-Simple

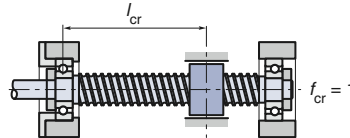

Fixed-Simple

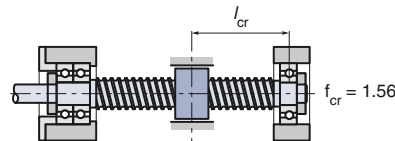

Fixed-Fixed

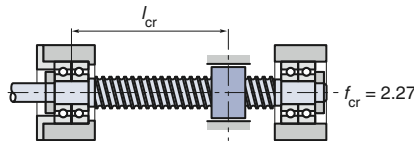

### Maximum Speed

A maximum rotational speed limit should be observed according to tolerance and shaft diameter regardless of critical speed limit compliance.

Tolerance class	Rotational speed limit [rpm]
P3, P5, T5	140,000/d <sub>0</sub> [mm]
T7	100,000/d <sub>0</sub> [mm]

### Critical Harmonic Speed Chart

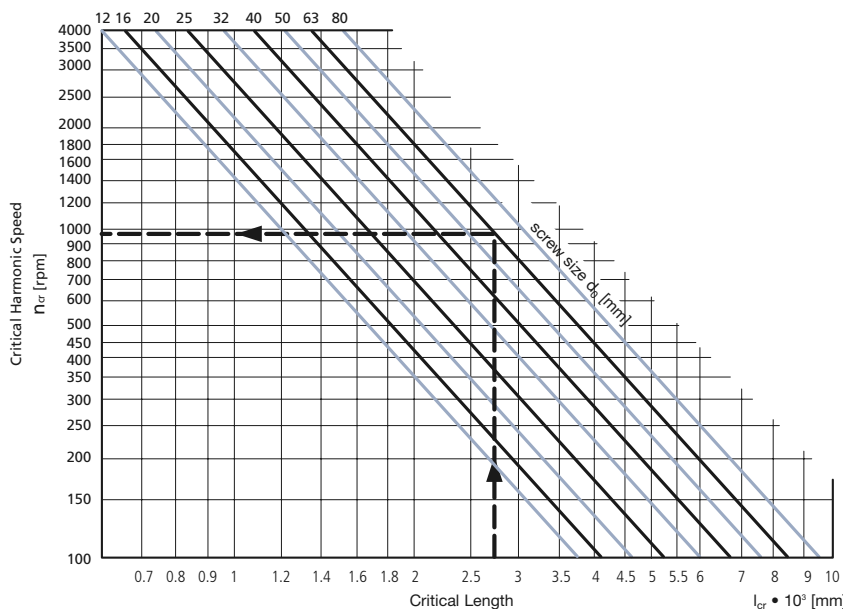

### Example:

Parameters:  
 $d_0 = 63 \text{ mm}$   
 $l_{cr} = 2700 \text{ mm}$   
 Fixed-simple loading

Reading from chart, using length and screw size, gives critical rotational speed  $n_{cr} = 970 \text{ rpm}$ . Fixed-simple mounting indicates speed adjustment factor of  $f_{cr} = 1.56$ . Thus, the recommended maximum speed is:

$$n_{crp} = 0.8 \times 970 \times 1.56$$

$$n_{crp} = 1210 \text{ rpm}$$

## Buckling

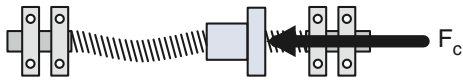

Compression loads (where force pushes on bearing and support) tend to cause the screw shaft to bend, requiring larger screw diameters than for comparably loaded tensile situations.

Where possible, applications should be designed for tension loading (where force pulls on bearing and support.)

Critical buckling force:

$$F_c = \frac{1.017 \times 10^5 \times d^4}{l_c^2} \text{ [N]}$$

Recommended maximum force:

$$F_{cp} = 0.8 \times F_c \times f_c \text{ [N]}$$

Parameters:

$$d \gg \frac{d_0 + d_3}{2} \text{ [mm]}$$

$d_0$  = nominal diameter [mm]

$$d_3 \gg d_0 - D_w \text{ [mm]}$$

$D_w$  = Ball  $\phi$  [mm]  
(see production specifications)

$l_c$  = stroke length [mm]

$f_c$  = mounting condition load adjustment factor

### Mounting Condition Effects

Fixed-Free

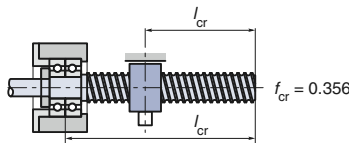

Simple-Simple

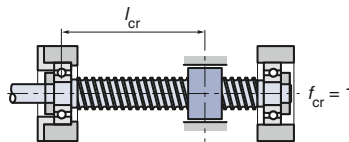

Fixed-Simple

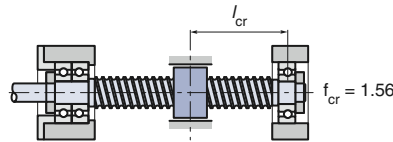

Fixed-Fixed

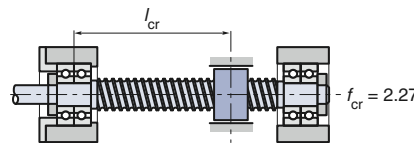

### Critical Buckling Force Chart

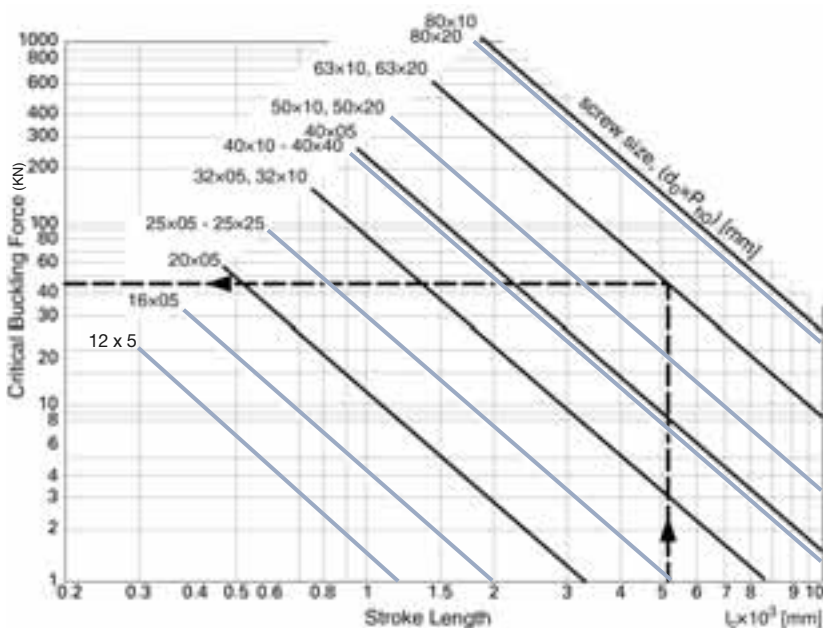

### Example:

Parameters:  
 $d_0 = 63 \text{ mm}$ ,  $Ph0 = 10 \text{ mm}$   
 $l_c = 5200 \text{ mm}$   
Fixed-simple loading

Reading from chart, using length and screw size, gives  $F_c = 45 \text{ kN}$ .

Fixed-simple loading indicates a mounting condition load adjustment factor of  $f_c = 2.0$  (from above). Thus, the recommended maximum load is:

$$F_{cp} = 0.8 \times 45 \times 2$$

$$F_{cp} = 72 \text{ kN}$$

## Lead Accuracy

### Permissible Travel Deviations

Lead accuracy is specified by a tolerance class. The primary difference between the two tolerance class types offered is the way they control

cumulative lead error. P class ball screws are more precise over long lengths than T class screws. Variation information for FineLine ball screws is given here.

#### P - Positioning Class Ball Screws

Maximum error over useful length =  $e_p + 1/2V_{up} + C$

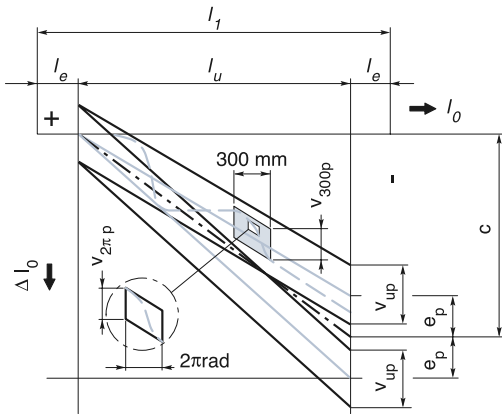

#### T - Transport Class Ball Screws

Maximum error over useful length =  $e_p$

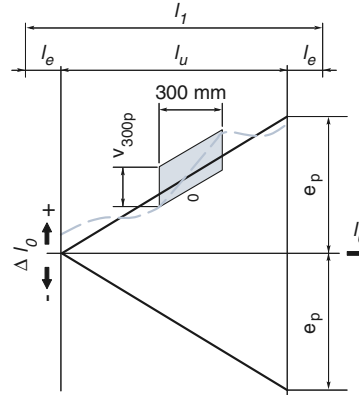

$l_1$  = Axial thread length

$l_u$  = Axial thread length

$l_e$  = Axial thread length

$l_o$  = Axial thread length

$\Delta l_o$  = Axial thread length

#### Parameters

		Accuracy Class		
		P3	P5	T5, T7
$V_{300p}$	Permissible travel variation within 300 mm travel	Table 1	Table 1	Table 1
$V_{2\pi p}$	Permissible travel variation within $2\pi$ travel	Table 1	Table 1	—
C	Compensation for temperature	—	—	—
$e_p$	Tolerance on useful travel	Table 3	Table 3	$2 \times \frac{l_u}{300} \times V_{300p}$
$V_{up}$	Permissible travel variation within useful travel $l_u$	Table 3	Table 3	—

#### Permissible travel variation (Table 1)

Tolerance Class	3	5	7
$V_{300p}$ [ $\mu\text{m}$ ]	12	23	52
$V_{2\pi p}$ [ $\mu\text{m}$ ]	6	8	—

#### Excess travel (Table 2)

Nominal Lead	$P_{ho}$ [mm]	$\leq 5$	$\leq 10$	$\leq 20$	$> 20$
Excess travel	$l_e$ [mm]	20	40	60	80

#### Permissible cumulative travel variation over long distances (Table 3)

	$l_u$	[mm]														
			$>$	$\leq$	315	400	500	630	800	1000	1250	1600	2000	2500	3150	4000
Tolerance Class	P3	$e_p$ [ $\mu\text{m}$ ]	12	13	15	16	18	21	24	29	35	41	50	62	76	—
		$V_{up}$ [ $\mu\text{m}$ ]	12	12	13	14	16	17	19	22	25	29	34	41	49	—
	P5	$e_p$ [ $\mu\text{m}$ ]	23	25	27	30	35	40	46	54	65	77	93	115	140	170
		$V_{up}$ [ $\mu\text{m}$ ]	23	25	26	29	31	35	39	44	51	59	69	82	99	119

## Accuracy Classes

Accuracy is a measure of how closely a motion system will approach a command position. Perfect accuracy, for example, means that advancing a ball nut a precise amount from a given point on the screw always requires exactly the theoretically predicted number of revolutions.

Accuracies may be specified by users in two ways:

- **Standards** have been developed for simplicity in grouping sets of accuracies. Tolerance classes have been established by ISO/DIN for the purpose of easily describing lead accuracies for ball screws.
- **Absolute terms** may define accuracies such as .0005 in/ft deviation (typically shown as tolerances on a drawing).

FineLine ball screws are produced in two main tolerance classes: T (transport) and P (positioning). Transport grade ball screws are used in applications requiring only coarse movement or those utilizing linear feedback for position location. As such, most transport grade screws are provided with nuts having backlash (T7 grade screws cannot be supplied with preloaded nuts). Precision grade ball screws are used where repeatable positioning within microns is critical, without the use of a linear feedback device.

Differences between P & T grades are highlighted in the graph above. T grade transport screws allow greater cumulative variation over the useful length of the screw. P grade positioning screws contain accumulation of lead error to provide precise positioning over the screw's entire useful length.

Position grade screws are used in applications such as CNC milling machines, medical imaging equipment, and lens grinding devices. In contrast, transport grade screws are used to drive door actuators or assembly line diverter gates.

Allowable Variation Per Tolerance Class

Tolerance Class	Permissible travel variation within 300 mm		Variation within one revolution ( $2\pi$ rad)	
	[ $\mu\text{m}$ ]	[in.]	[ $\mu\text{m}$ ]	[in.]
P3	12	.0005	6	.0002
P5	23	.0009	8	.0003
T5	23	.0009	8	.0003
T7	52	.0020	12	.0005

Cumulative Lead Variation Over Usable Length

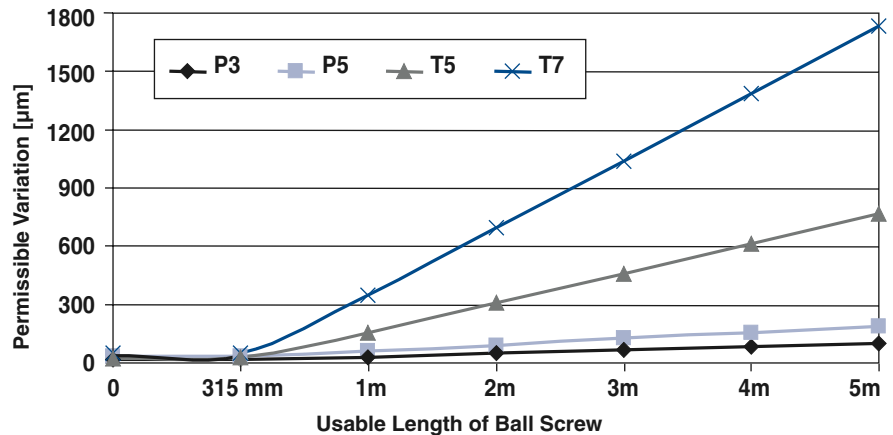



## Preload Classes

FineLine Ball Screws are available in three preload classes: Clearance Grade (no preload), Preload (lightly preloaded with four points of contact) and Precise Preload (preloaded with two points of contact to exact customer specifications).

**Precise Preload (Type Z0)**  
 (Precisely preloaded to customer specifications)

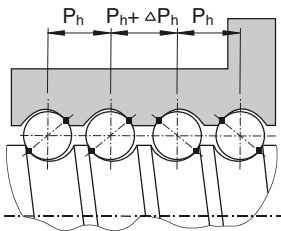

### Precise Preload

The lead is offset by an amount,  $DPh$ , to preload with two points of contact around the balls as shown.

- Offers zero backlash between screw and nut.
- The preload is approximately 10% of dynamic load capacity, but can range from 2% to 13% as specified by customers. Drag torque is controlled within a designated range.
- Typically used for positioning applications where repeatability and high stiffness are required (high stiffness allows for high load carrying with minimum deflection).

(Available only with FL nut.)

**Preload (Type Z1)**  
 (Lightly preloaded)

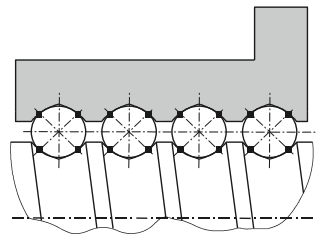

### Preloaded

Oversized balls slightly larger than the ball groove space are used to provide four points of contact.

- Offers zero backlash between screw and nut.
  - The preload is approximately 5% of dynamic load capacity.
  - Typically used for positioning applications where repeatability is critical.
- (Available with FK, FH & ZG style nuts.)

**Clearance Grade (Type Z2)**  
 (No preload)

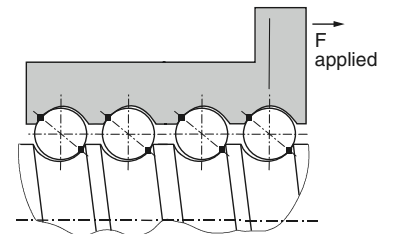

### No Preload

Ball bearings are undersized, thereby creating clearance between the nut and screw.

- Axial play is present between screw and nut, which negatively affects repeatability.
  - Introduces no additional drag torque.
  - Lead accuracy is unaffected, repeatability is approximately equal to backlash amount. (Typical maximum backlash is .09 to .18 mm, depending on size.)
  - Typically used for transport applications or vertical applications where low drag is desirable.
- (Available with FK, FH & ZG style nuts.)

## Ball Circulation Techniques

A critical aspect of ball nut design is the manner in which the ball bearings are recirculated through the nut.

Danaher Motion has done extensive research on ball nut design, and has engineered two internal return systems: the single-liner ball return system and the end-cap ball return system. Internal systems are compact, offer no protrusions to complicate mounting, are less likely to be damaged, and are designed to optimize ball circulation and rotational speed.

The **single-liner** design allows the balls to travel one rotation about the screw before being diverted into the insert and back one thread pitch. Four or more liners are used to provide the necessary number of loaded turns to achieve the desired load capacity. Successive liners are typically staggered circumferentially about the body of the nut to balance the total ball contact around the screw. The simplicity of design and economy of motion result in a compact and reliable ball return assembly. The return design is primarily used on fine lead screws.

For higher leads, **end-cap** designs are preferable. The balls are allowed to rotate around the screw for the length of the nut before being re-directed by the end cap. This internal return channel runs from one end of the nut to the other and carries the balls back to the beginning of the circuit. The second end cap re-engages the balls with the screw, completing the circuit. The end cap design eliminates dead zones in the ball nut and optimizes load capacity. Rotational speed is enhanced through the geometry of the end cap diverter and the few number of returns required.

### Single-liner Ball Return System

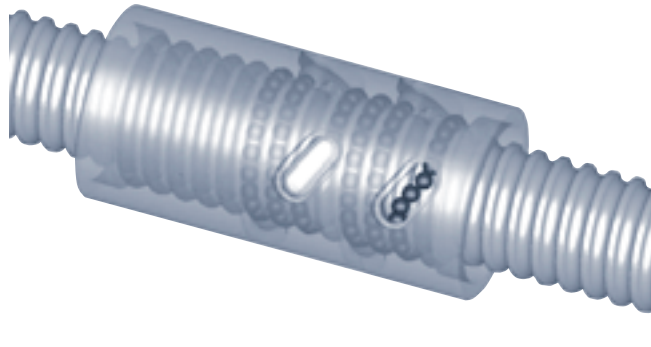

The single-liner ball return design is used for the FK, FL & ZG type nuts.

### End-Cap Ball Return System

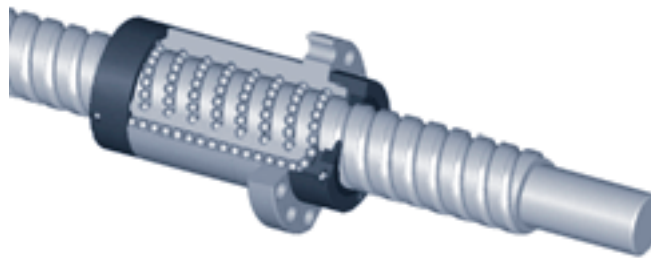

The end-cap design offers distinct advantages and is the system used for the FH type nuts

## Typical Ends

The typical ends shown below can be machined on Thomson ball screws. The shaded areas of the drawings represent the extension required for a keyed drive coupling. Specific dimensional data is provided in the chart.

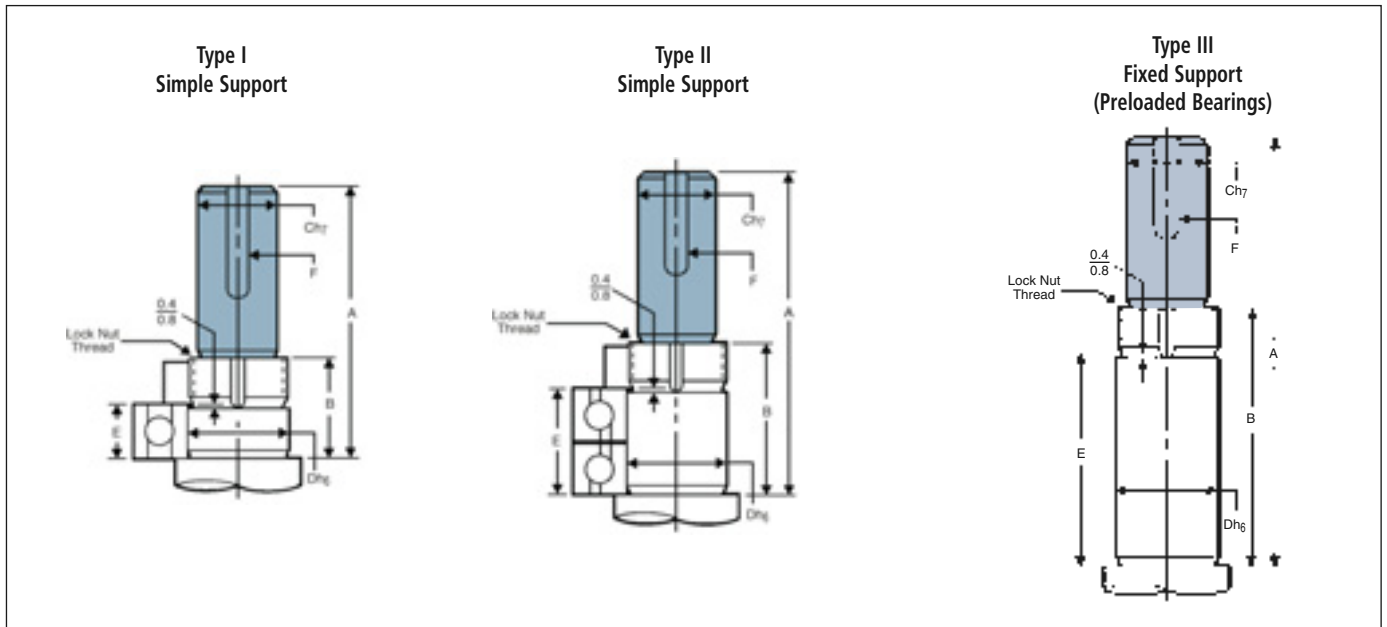

Screw Size	Type I <sup>(1)</sup>			Type II <sup>(1)</sup>			Type III <sup>(1)</sup>			Type I, II, III				
	Typical Journal for Single Mounted Bearing			Typical Journal for Duplex Mounted Bearings			Typical Journal for 1 or 2 Sets of Duplex Mounted Bearings			Dimensions Common to End Configurations				
	A	B	E	A	B	E	A	B	E	Ch <sub>7</sub>	Dh <sub>6</sub>	F	Lock Nut Thread	Angular Contact Bearing Part No.
12	46	19	7	53	26	14	73	46	36	6	9	N/A	M8 x 1.25	708
16	54	21	10	64	31	20	84	51	40	10	12	3 x 1.8	M12 x 1	201
20	47	22	11	58	33	22	80	55	44	12	15	4 x 2.5	M15 x 1	202
25	61	27	14	75	41	28	103	69	56	16	20	5 x 3.0	M20 x 1	204
32	68	29	15	83	44	30	113	74	60	20	25	5 x 3.0	M25 x 1.5	205
40	76	30	16	92	46	32	124	78	64	25	30	8 x 4.0	M30 x 1.5	206
50	95	40	23	118	63	46	164	109	92	32	40	8 x 4.0	M40 x 1.5	308
63	116	43	27	143	70	54	197	124	108	40	50	10 x 5	M50 x 1.5	310
80	142	48	31	173	79	62	235	141	124	50	60	12 x 6	M60 x 2	312

All dimensions in mm.

<sup>(1)</sup> To provide for bearings with higher load capacity than those available for these typical ends, adapters can be used to increase the diameter.

## Precision Metric Product Specification Summary

### Lead Accuracy T5

Nominal Dia. (mm)	Lead (mm)	Direction	Screw Part Number	Root Diameter (mm)	Maximum Lengths Available (mm)	Use with these ball nuts		Weight (kg/m)	Use with these Mounting Blocks
						ZG	FS		
12	4	RH	7832770-T5	9.7	3000	7832771		0.7	7829546
12	5	RH	7832772-T5	9.0	3000	7832774	7832775	0.7	7829546
16	5	RH	7832776-T5	12.7	3000	7832778		1.2	7829547
20	5	RH	7832779-T5	16.7	4000	7832781	7832782	2.0	7829548
	20	RH	7832783-T5	16.7	4000		7832785	1.9	7829548
25	5	RH	7832786-T5	21.7	5000	7832788	7832789	3.3	7829549
	10	RH	7832790-T5	21.7	5000	7832792		3.3	7829549
	25	RH	7832793-T5	21.7	5000			3.3	7829549
32	5	LH	7832795-T5	28.7	6000	7832797		5.6	7829550
	10	RH	7832798-T5	27.1	6000	7832800	7832801	5.3	7829550
	25	RH	7832802-T5	27.1	6000			5.3	7829550
40	5	RH	7832804-T5	36.7	6000	7832806	7832806	9.0	7829551
	10	RH	7832808-T5	34.0	6000	7832810		8.3	7829551
	20	RH	7832811-T5	35.2	6000		7832813	7.6	7829551
	40	RH	7832814-T5	34.0	6000		7832816	8.4	7829551
50	10	RH	7832817-T5	43.0	6000	7832819		13.5	7829552
	20	RH	7832820-T5	44.6	6000			13.6	7829552
63	10	RH	7832822-T7†	56.9	6000	7832824		22.0	7829553
	20	RH	7832828-T7†	56.9	6000			22.0	7829553
80	10	RH	7832827-T7†	73.9	6000	7832829		36.4	

\* Note: Customer to verify bearings are sufficient for application  
Alternate lengths available on request (consult factory)  
† T-7 Accuracy only

## Precision - Metric Product Availability

Lead (in)

Dia. (in)	Lead (in)								
	4	5	5.08	10	20	25	32	40	
12	●	●							
16		●	●						
20		●			●				
25		●		●		●			
32		●		●	●		●		
40		●		●	●			●	
50				●	●				
63*				●	●				
80*				●	●				

\* T-7 accuracy only

● = stocked size  
● = on request

## Precision - Metric



### Thomson Metric Precision Ball Screws offer:

- Availability in a full range of diameters, leads, and nut configurations, in either preloaded or non-preloaded types, all industry standard envelopes.
- Over 90% efficiency with a constant low coefficient of friction. When replacing conventional actuation systems such as Acme screws, hydraulics, or pneumatics, they allow the use of smaller, less-expensive drive motors and reduce the need for auxiliary equipment.
- Dependable accuracy and repeatability at an economical price.
- A Gothic arch ball groove geometry that extends service life, reduces lash, and optimizes stiffness in preloaded assemblies.
- Optional end support blocks, which increase system efficiency and service life.
- Availability through over 1800 authorized Danaher Motion distributors worldwide.

## Precision - Metric (T5 Class)

ZG - Standard Threaded Ball Nuts - Clearance Type Z2 & Preload Grade Type Z1

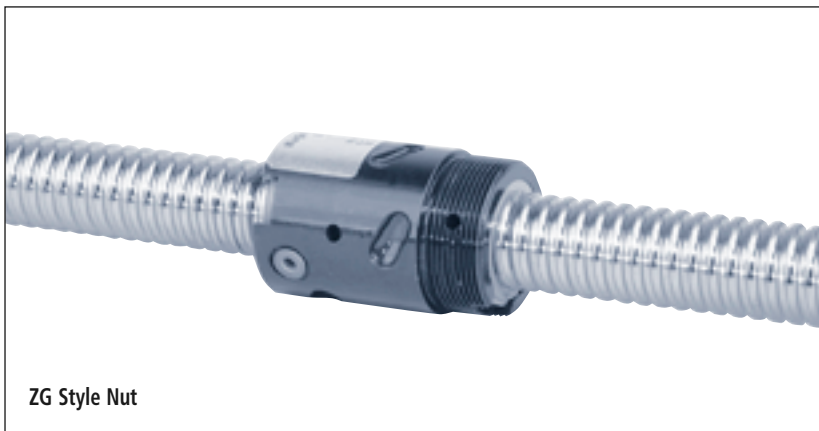

ZG Style Nut

### Standard Threaded Ball Nut and Screw

- Available with preload or no preload
- Solution for non-standard mounting

## Performance Specifications for Ball Screws with Threaded Ball Nuts

Screw P/N	Ball Nut P/N	Nom. Nut			Performance Data					Screw Dimensions				
		Diam.	Lead	Type	Dynamic Load Capacity ( $C_{am}$ )		Static Load Capacity ( $C_{am}$ )		Max Axial Backlash	Major Ø	Minor Ø	Max Length	Screw Weight	
		$d_0$ [mm]	$P_{ho}$ [mm]		[kN]	[lbf]	[kN]	[lbf]	[mm]	[mm]	[mm]	[kg/m]	[lb/ft]	
7832770-T5	7832771	12	4	ZG	3.5	787	4	899	0.07	11.6	9.7	3000	0.7	0.47
7832772-T5	7832774	12	5	ZG	5.6	1259	6.2	1393	0.07	11.6	9.7	3000	0.7	0.47
7832776-T5	7832778	16	5	ZG	12.1	2720	14.5	3260	0.09	15.6	12.7	3000	1.2	0.81
7832779-T5	7832781	20	5	ZG	14.8	3327	20.7	4653	0.09	19.6	16.7	4000	2	1.34
7832786-T5	7832788	25	5	ZG	20.4	4586	33.7	7576	0.09	24.6	21.7	5000	3.3	2.22
7832790-T5	7832792	25	10	ZG	19.9	4474	31.8	7149	0.09	24.6	21.7	5000	3.3	2.22
7832795-T5	7832797	32	5	ZG	23.3	5238	45.5	10228	0.09	31.6	28.7	6000	5.6	3.76
7832798-T5	7832800	32	10	ZG	33.8	7598	52	11690	0.15	31.6	27.1	6000	5.3	3.56
7832804-T5	7832806	40	5	ZG	26.3	5912	59.2	13308	0.09	39.6	36.7	6000	9	6.05
7832808-T5	7832810	40	10	ZG	78.6	17669	136.2	30618	0.18	39.6	34	6000	8.3	5.58
7832817-T5	7832819	50	10	ZG	97.8	21985	213.2	47927	0.18	49.5	43	6000	13.5	9.07
7832822-T7†	7832824	63	10	ZG	109.7	24661	275.6	61955	0.18	62.5	56.9	6000	22	14.78
7832872-T7†	7832829	80	10	ZG	121.9	27403	375	84300	0.18	79.5	73.9	6000	36.4	24.46

Note: T-5 accuracy.

† T-7 Accuracy only in these units.

## Precision - Metric

### ZG - Standard Threaded Ball Nuts - Clearance & Preload Grade

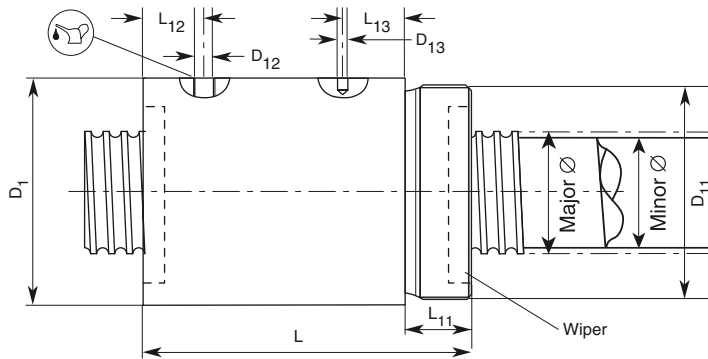

### Dimensional Specifications for Ball Screw nuts with Threaded Ball Nuts

Nom. Diam.	Lead	Nut Type	Nut Dimensions [mm]									Nut Weight		Ball Ø (Dw)
			D <sub>1</sub>	D <sub>11</sub>	D <sub>12</sub>	D <sub>13</sub>	L	L <sub>11</sub>	L <sub>12</sub>	L <sub>13</sub>	[kg/m]	[lb/ft]		
d <sub>0</sub>	P <sub>ho</sub>		D <sub>1</sub>	D <sub>11</sub>	D <sub>12</sub>	D <sub>13</sub>	L	L <sub>11</sub>	L <sub>12</sub>	L <sub>13</sub>				
[mm]	[mm]		h12			±0.1	±1	-0.5	±2	±2				
12	4	ZG	25.5	M 20 x 1.0	3.2	-	34	10	12.0	-	0.1	0.22	1.984	
12	5	ZG	25.5	M20 x 1.0	3.2	-	34	10	12.0	-	0.1	0.22	1.984	
16	5	ZG	32	M 30 x 1.5	M 6 x 1	4	57.5	16.5	10.5	22.0	0.22	0.49	3.500	
20	5	ZG	38	M 35 x 1.5	M 6 x 1	4	57.5	16.5	10.5	22.0	0.3	0.66	3.500	
25	5	ZG	42	M 40 x 1.5	M 6 x 1	4	63.5	17	10.5	23.0	0.37	0.82	3.500	
25	10	ZG	42	M 40 x 1.5	M 6 x 1	4	61	17	10.0	21.0	0.38	0.84	3.500	
32	5	ZG	52	M 48 x 1.5	M 6 x 1	5	65.5	19	10.5	23.0	0.55	1.21	3.500	
32	10	ZG	52	M 48 x 1.5	M 6 x 1	5	85	19	12.0	43.0	0.65	1.43	5.556	
40	5	ZG	58	M 56 x 1.5	M 8 x 1	5	67.5	19	12.0	22.5	0.6	1.32	3.500	
40	10	ZG	65	M 60 x 2.0	M 8 x 1	6	105.5	27	13.0	43.0	1.25	2.76	7.144	
50	10	ZG	78	M 72 x 2.0	M 8 x 1	6	118	29	13.0	53.0	1.95	4.30	7.144	
63	10	ZG	92	M 85 x 2.0	M 8 x 1	6	118	29	13.0	53.0	2.4	5.29	7.144	
80	10	ZG	120	M 110 x 2.0	M 8 x 1	8	126	34	15.5	53.0	4.9	10.8	7.144	

## Precision - Metric (T-5)

### FS - Standard 5-Bolt Flanged Ball Nuts - Clearance and Preload Grade



FS Style Nut

#### Standard 5-Bolt Flanged Ball Nut and Screw

- Available with preload or no preload
- Shortest nut length possible
- Excellent economical solution

## Performance Specifications for Ball Screws with 5-Bolt Flanged Ball Nuts

### Metric Series

Ball Screw p/n T-5	Ball Nut p/n	Product Size		Type Nut	Performance Data				Screw Dimensions					
		D <sub>0</sub> (mm)	P <sub>ho</sub> (mm)		Dynamic (kN) (lbf)		Static (kN) (lbf)		Max Axial Back Lash (mm)	Major Dia. (mm)	Minor Dia. (mm)	Max Length (mm)	Screw Weight (kg/m) (lb/ft.)	
7832772-T5	7832775	12 x 5		FS	5.6	1259	6.2	1394	0.07	11.6	9.7	3000	0.7	0.47
7832779-T5	7832782	20 x 5		FS	11.1	2500	15.1	3395	0.09	19.6	16.7	4000	2.0	1.34
7832783-T5	7832785	20 x 20		FS	8.5	1911	11.3	2540	0.09	19.6	16.7	4000	1.9	1.34
7832786-T5	7832789	25 x 5		FS	14.3	3215	22.3	5014	0.09	24.6	21.7	5000	3.3	2.22
7832798-T5	7832801	32 x 10		FS	27.4	6161	42.5	9556	0.15	31.6	27.1	6000	5.3	3.56
7832804-T5	7832807	40 x 5		FS	18.3	4115	39.1	6792	0.09	39.6	36.7	6000	9.0	6.05
7832811-T5	7832813	40 x 20		FS	31.0	6970	47.0	10568	0.15	39.6	35.2	6000	7.6	5.11
7832814-T5	7832816	40 x 40		FS	29.8	6700	45.4	10208	0.18	39.6	34.0	6000	8.4	5.64

All dimensions in mm.

Nuts are only shipped assembled on Class 5 screw stock.

\*Specify preloaded or non-preloaded on quote request.

\*\*Dynamic load capacity is based on 10<sup>6</sup> revolutions per ISO-3408-5.

†These are external return or end return products. Consider in the DN evaluation.



### Precision - Metric (T-5)

#### FS - Standard 5-Bolt Flanged Ball Nuts - Clearance and Preload Grade

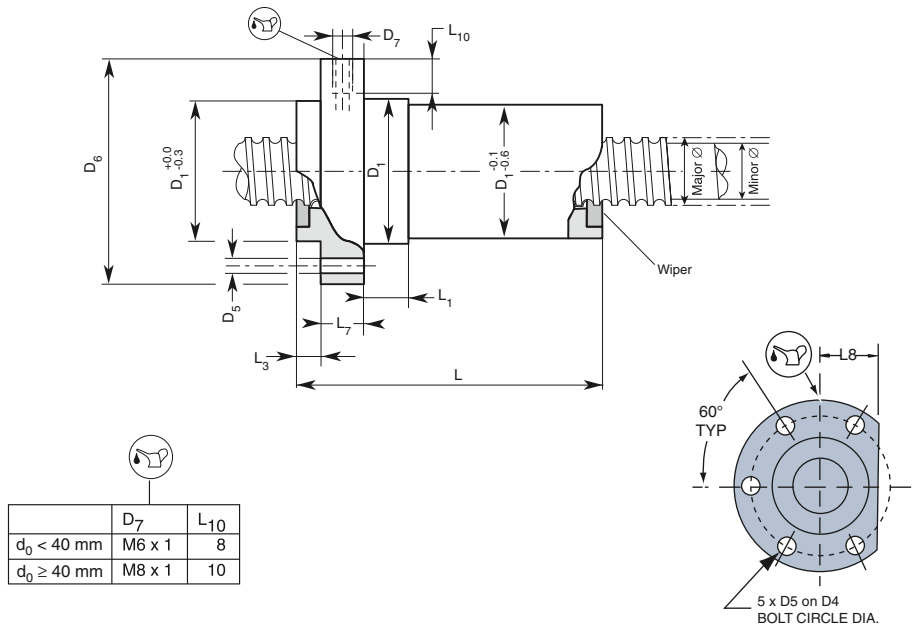

#### Performance Specifications for Ball Screws with Flanged Ball Nuts

Nom. Diam.	Lead	Type Nut	Nut Dimensions [mm]											Nut Weight		Ball Dia. (mm)
			$d_0$ [mm]	$P_{ho}$ [mm]	$D_1$	$D_4$	$D_5$	$D_6$	L	$L_1$	$L_3$	$L_7$	$L_8$	(kg)	(lbm)	
12 x 5		FS	24	32	4.6	40	45	11	0	12	14.0	0.15	0.33	1.984		
20 x 5		FS	33	45	6.6	58	48	12	0	15	22.0	0.35	0.77	3.500		
20 x 20		FS	40	50	6.6	63	83	15	0	20	21.0	0.45	0.99	3.500		
25 x 5		FS	38	50	6.6	63	53	11	0	20	21.0	0.37	0.82	3.500		
32 x 10		FS	50	65	9.0	80	72	12	0	12	28.5	0.8	1.76	5.556		
40 x 5		FS	56	68	6.6	80	53	12	0	19	30.0	1.2	2.65	3.500		
40 x 20		FS	75	93	11.0	110	88	15	0	16	42.5	1.6	3.53	5.556		
40 x 40		FS	72	93	11.0	110	126	16	0	16	42.5	2.4	5.29	7.144		

**NOTES:**

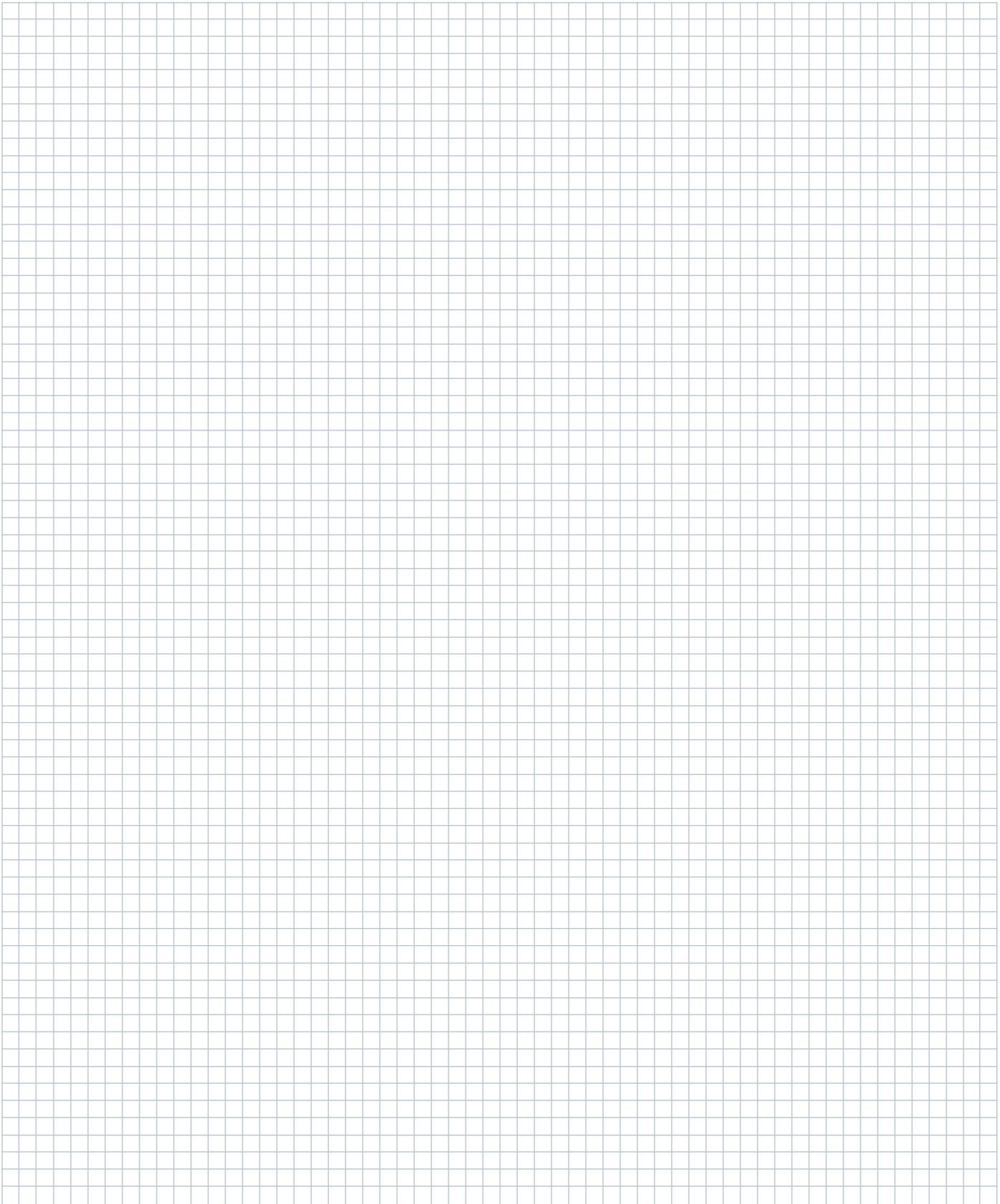

## FineLine - Metric (P5 & P3 Class)

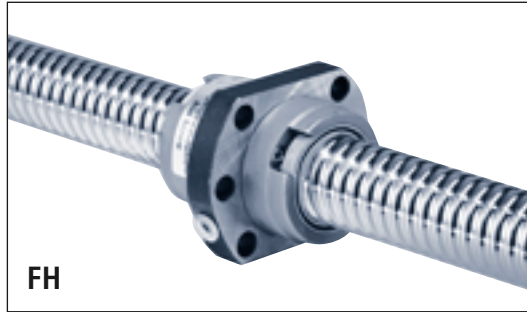
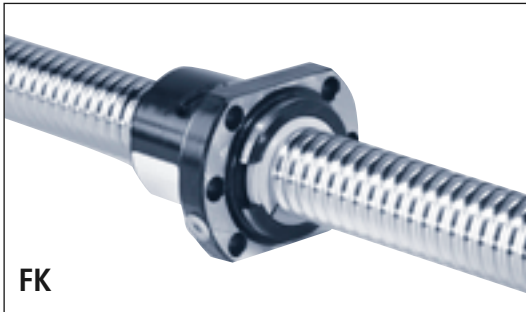

### Thomson Metric FineLine Ball Screws offer:

- Availability in a full range of diameters, leads, and nut configurations, in either preloaded or non-preloaded types, all in industry standard envelopes.
- Over 90% efficiency with a constant low coefficient of friction. When replacing conventional actuation systems such as Acme screws, hydraulics, or pneumatics, they allow the use of smaller, less-expensive drive motors and reduce the need for auxiliary equipment.
- Dependable accuracy and repeatability at an economical price.
- A Gothic arch ball groove geometry that extends service life, reduces lash, and optimizes stiffness in preloaded assemblies.
- Optional wiper kits and end support blocks, which increase system efficiency and service life.
- Availability through over 1800 authorized Danaher Motion distributors worldwide.

## FineLine - Metric Product Availability

Dia. (in)	Lead (in)						
	4	5	10	20	25	32	40
12	●						
16		●					
20		●	●	●			
25		●	●		●		
32		●	●			●	
40		●	●	●			●
50			●	●			
63			●	●			

- = stocked size
- = on request

## FineLine Metric Product Summary

### Lead Accuracy P-5

Nominal Dia. (mm)	Lead (mm)	Direction	Screw Part Number	Root Diameter (mm)	Maximum Lengths Available (mm)	Weight (kg/m)	Use with these ball nuts FK/FH	Mounting Blocks
12	5	RH	7832772-P5	9.0	3000	0.7	783773	7829546
16	5	RH	7832776-P5	12.7	3000	1.2	783777	7829547
20	5	RH	7832779-P5	16.7	4000	2.0	783780	7829548
	20	RH	7832783-P5	16.7	4000	1.9	783784	7829548
25	5	RH	7832786-P5	21.7	5000	3.3	783787	7829549
	10	RH	7832790-P5	21.7	5000	3.3	783791	7829549
	25	RH	7832793-P5	21.7	5000	3.3	783794	7829549
32	5	RH	7832795-P5	28.7	6000	5.6	783796	7829550
	10	RH	7832798-P5	27.1	6000	5.3	783799	7829550
	20	RH	7832802-P5	27.1	6000	5.3	783803	7829550
40	5	RH	7832804-P5	36.7	6000	9.0	783805	7829551
	10	RH	7832808-P5	34.0	6000	8.3	783809	7829551
	20	RH	7832811-P5	35.2	6000	7.6	783812	7829551
	40	RH	7832814-P5	34.0	6000	8.4	783815	7829551
50	10	RH	7832817-P5	43.0	6000	13.5	783818	7829552
	20	RH	7832820-P5	44.6	6000	13.6	783821	7829552
63	10	RH	7832822-P7 <sup>†</sup>	56.9	6000	22.0	783823	7829553
	20	RH	7832828-P7 <sup>†</sup>	56.9	6000	22.0	783826	7829553
80	10	RH	7832827-P7 <sup>†</sup>	73.9	6000	36.4	783828	—

† T-7 in these sizes only.

The Danaher Motion patented, German-engineered Precision Screw Forming (PSF) Technology has created a higher performing ball screw, combining outstanding precision—traditionally only associated with ground screws—with the manufacturing efficiency of rolled processes. The result is an affordable ball screw with highest precision and outstanding performance.

FineLine ball screws are equal in accuracy and performance to ground screws of the same accuracy class, but with harder grain structures (see inset), lower costs, and short manufacturing times (provides significantly reduced lead times for our customers). PSF Technology consistently produces screws with accuracies ranging up to P3 class tolerances (ISO 3408 standard), a dramatic improvement over existing rolled manufacturing processes that typically produce only transport-grade screws (up to class 7). PSF Technology brings affordable precision to a range of new applications.

### What is PSF Technology?

Precision Screw Forming is an exacting manufacturing process that results in a superior ball screw. First, high carbon alloy steel blanks are processed into screws of length up to four meters (over 13 feet) in a special CNC-controlled, dual-movable-die, cold-forming machine. Second, the screw forms are induction-hardened and stress-relieved. Next, the screws are polished to produce a ball track with surface toughness superior to a ground screw. Finally, the ball screw is mated with its nut (loaded to user specifications), inspected and tested to customer requirements. The result is a high precision, high quality ball screw/nut assembly.

### What are the Benefits of PSF Technology?

Here are just some of the benefits associated with ball screws made using PSF Technology:

1. FineLine ball screws offer low cost, high precision performance in applications typically requiring ground screws. FineLine also offers the opportunity for greater precision in applications where ground screws have been too expensive to consider.
2. Responsive manufacturing & delivery times: PSF Technology is a fast, non-batch manufacturing process, with delivery times of less than two weeks, compared with the typical 2-3 month lead times of ground ball screws.

3. No hard spots: The PSF process does not expose hard spots (“corns”) as grinding does. Hard spots can mar ball surfaces and shorten screw life by up to 20%.
4. Quieter running: The superior surface finish of FineLine ball screws gives smooth operations with minimal noise.

### FineLine Ball Screws – Better Grain Structures

In addition to equaling some of the top accuracy classes of ground screws, our FineLine Ball Screws offer a distinct advantage over ground screws in the screw’s arch. Screw rolling displaces grains, producing arch-shaped grain structures, while grinding removes material and leaves asperities exposed in the grain structure. FineLine rolled screws thus have increased rust resistance, and a stronger, arched grain structure that induces hardness under the surface of the screw.

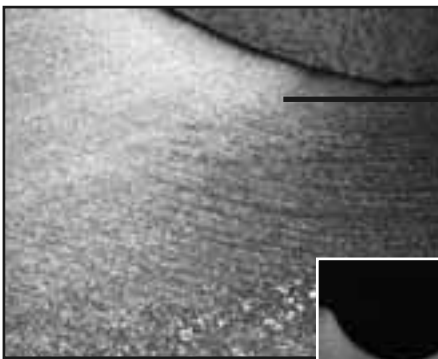

Micrograph shows smooth, arched grain structure of a screw manufactured using PSF Technology.

### FineLine Ball Screws with PSF Technology

Arched grain provides increased strength, hardness and durability, resulting in reduced friction and increased life.



Profile of a rolled PSF Technology screw

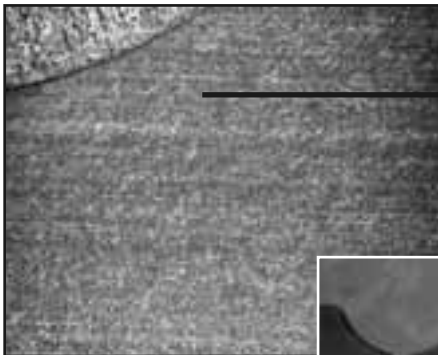

Micrograph shows grain structure of a ground screw.

### Typical Ground Ball Screw

Grinding the screw reduces the integrity of the steel and leaves exposed asperities in the grain structure, which can reduce efficiency and useful life.

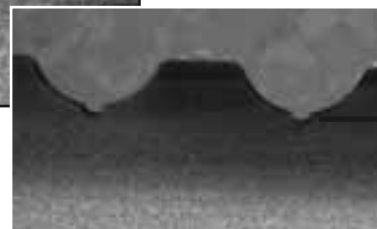

Profile of a ground screw

## Accuracy Classes

Accuracy is a measure of how closely a motion system will approach a command position. Perfect accuracy, for example, means that advancing a ball nut a precise amount from a given point on the screw always requires exactly the theoretically predicted number of revolutions.

Accuracies may be specified by users in two ways.

- **Standards** have been developed for simplicity in grouping sets of accuracies. Tolerance classes have been established by ISO/DIN for the purpose of easily describing lead accuracies for ball screws.
- **Absolute terms** may define accuracies such as .0005 in/ft deviation (typically shown as tolerances on a drawing).

FineLine ball screws are produced in two main tolerance classes: T (transport) and P (positioning). Transport grade ball screws are used in applications requiring only coarse movement or those utilizing linear feedback for position location. As such, most transport grade screws are provided with nuts having backlash (T7 grade screws cannot be supplied with preloaded nuts). Precision grade ball screws are used where repeatable positioning within microns is critical, without the use of a linear feedback device.

Differences between P & T grades are highlighted in the graph above. T grade transport screws allow greater cumulative variation over the useful length of the screw. P grade positioning screws contain accumulation of lead error to provide precise positioning over the screw's entire useful length.

Position grade screws are used in applications such as CNC milling machines, medical imaging equipment, and lens grinding devices. In contrast, transport grade screws are used to drive door actuators or assembly line diverter gates.

Allowable Variation Per Tolerance Class

Tolerance Class	Permissible travel variation within 300 mm		Variation within one revolution ( $2\pi$ rad)	
	[ $\mu\text{m}$ ]	[in.]	[ $\mu\text{m}$ ]	[in.]
P3	12	.0005	6	.0002
P5	23	.0009	8	.0003
T5	23	.0009	8	.0003
T7	52	.0020	12	.0005

Cumulative Lead Variation Over Usable Length

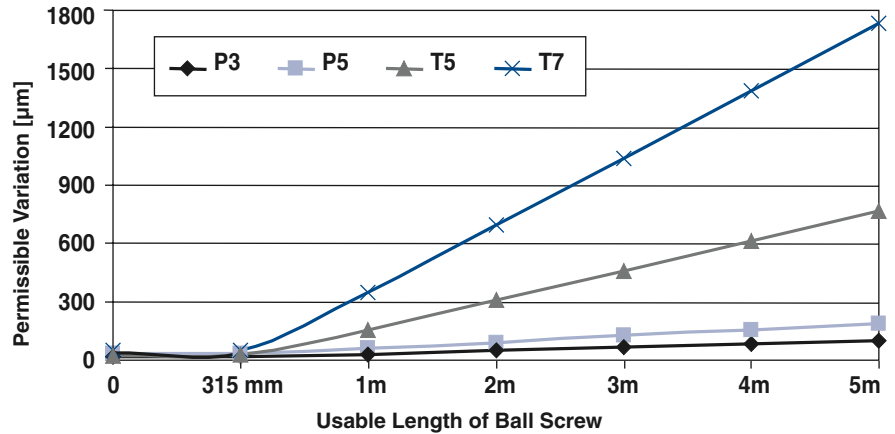

## Preload Classes

FineLine Ball Screws are available in three preload classes: Clearance Grade (no preload), Preload (lightly preloaded with four points of contact) and Precise Preload (preloaded with two points of contact to exact customer specifications).

**Precise Preload (Type Z0)**  
 (Precisely preloaded to customer specifications)

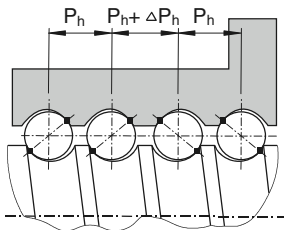

**Precise Preload**  
 The lead is offset by an amount,  $\Delta P_h$ , to preload with two points of contact around the balls as shown.

- Offers zero backlash between screw and nut.
  - The preload is approximately 10% of dynamic load capacity, but can range from 2% to 13% as specified by customers. Drag torque is controlled within a designated range.
  - Typically used for positioning applications where repeatability and high stiffness are required (high stiffness allows for high load carrying with minimum deflection).
- (Available only with FL nut.)

**Preload (Type Z1)**  
 (Lightly preloaded)

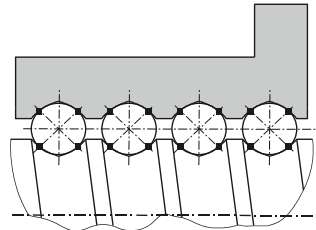

**Preloaded**  
 Oversized balls slightly larger than the ball groove space are used to provide four points of contact.

- Offers zero backlash between screw and nut.
  - The preload is approximately 5% of dynamic load capacity.
  - Typically used for positioning applications where repeatability is critical.
- (Available with FK, FH & ZG style nuts.)

**Clearance Grade (Type Z2)**  
 (No preload)

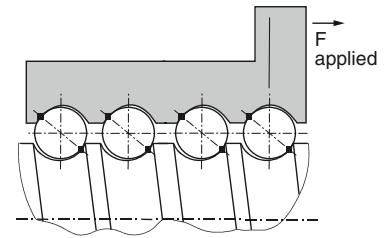

**No Preload**  
 Ball bearings are undersized, thereby creating clearance between the nut and screw.

- Axial play is present between screw and nut, which negatively affects repeatability.
  - Introduces no additional drag torque.
  - Lead accuracy is unaffected, repeatability is approximately equal to backlash amount. (Typical maximum backlash is .09 to .18 mm, depending on size.)
  - Typically used for transport applications or vertical applications where low drag is desirable.
- (Available with FK, FH & ZG style nuts.)

## Ball Circulation Techniques

A critical aspect of ball nut design is the manner in which the ball bearings are recirculated through the nut.

Danaher Motion has done extensive research on ball nut design, and has engineered two internal return systems: the single-liner ball return system and the end-cap ball return system. Internal systems are compact, offer no protrusions to complicate mounting, are less likely to be damaged, and are designed to optimize ball circulation and rotational speed.

The **single-liner** design allows the balls to travel one rotation about the screw before being diverted into the insert and back one thread pitch. Four or more liners are used to provide the necessary number of loaded turns to achieve the desired load capacity. Successive liners are typically staggered circumferentially about the body of the nut to balance the total ball contact around the screw. The simplicity of design and economy of motion result in a compact and reliable ball return assembly. The return design is primarily used on fine lead screws.

For higher leads, **end-cap** designs are preferable. The balls are allowed to rotate around the screw for the length of the nut before being re-directed by the end cap. This internal return channel runs from one end of the nut to the other and carries the balls back to the beginning of the circuit. The second end cap re-engages the balls with the screw, completing the circuit. The end cap design eliminates dead zones in the ball nut and optimizes load capacity. Rotational speed is enhanced through the geometry of the end cap diverter and the few number of returns required.

### Single-liner Ball Return System

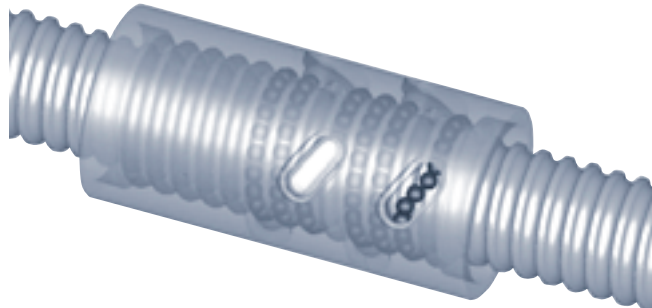

The single-liner ball return design is used for the FK, FL & ZG type nuts.

### End-Cap Ball Return System

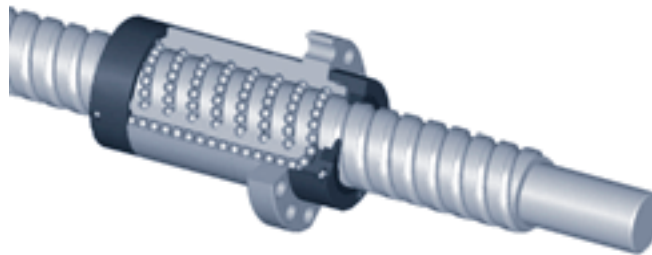

The end-cap design offers distinct advantages and is the system used for the FH type nuts



## FineLine - Metric (P3 & P5 Class)

### FK & FH - Standard Flanged Ball Nuts - Clearance & Preload Grade

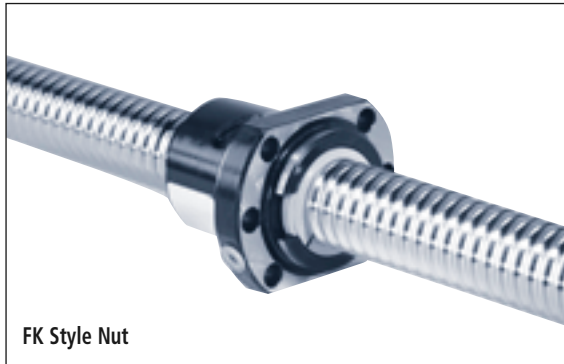

FK Style Nut

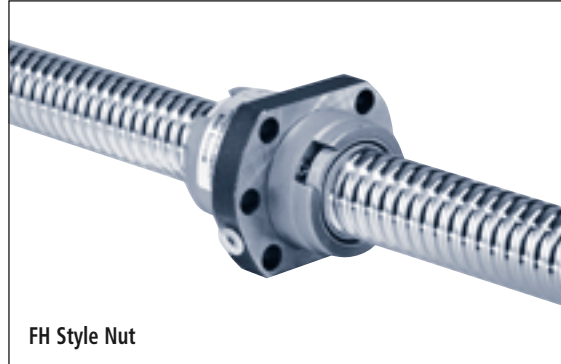

FH Style Nut

#### Standard Flanged Ball Nut and Screw

- Available with preload or no preload
- Shortest nut length possible
- Excellent economical solution

### Performance Specifications for Ball Screws with Flanged Ball Nuts

Screen P/N P5	Ball Nut P/N	Nom. Diam. Lead		Nut Type	Performance Data					Screw Dimensions				
		d <sub>0</sub> [mm]	P <sub>ho</sub> [mm]		Dynamic Load Capacity (C <sub>am</sub> )		Static Load Capacity (C <sub>am</sub> )		Max Axial Backlash	Major Ø	Minor Ø	Max Length	Screw Weight	
					[kN]	[lbf]	[kN]	[lbf]	[mm]	[mm]	[mm]	[kg/m]	[lb/ft]	
7832772-P5	7832773	12	5	FK	5.6	1259	6.2	1393	0.07	11.6	9.7	3000	0.7	0.47
7832776-P5	7832777	16	5	FK	9.5	2136	10.9	2450	0.09	15.6	12.7	3000	1.2	0.81
7832779-P5	7832780	20	5	FK	11.5	2585	15.5	32484	0.09	19.6	16.7	4000	2	1.34
7832783-P5	7832784	20	20	FH	11.5	2585	17.5	3934	0.09	19.6	16.7	4000	1.9	1.28
7832786-P5	7832787	25	5	FK	13.1	2945	20.2	4541	0.09	24.6	21.7	5000	3.3	2.22
7832790-P5	7832791	25	10	FH	22.9	5148	141.2	31742	0.09	24.6	21.7	5000	3.3	2.22
7832793-P5	7832794	25	25	FH	13	2922	22.6	5080	0.09	24.6	21.7	5000	3.3	2.22
7832795-P5	7832796	32	5	FK	19.3	4339	363	81602	0.09	31.6	28.7	6000	5.6	3.76
7832798-P5	7832799	32	10	FK	26.4	5935	39	8767	0.15	31.6	27.1	6000	5.3	3.56
7832802-P5	7832803	32	20	FH	47.2	10611	83.2	18703	0.15	31.6	27.1	6000	5.3	3.56
7832804-P5	7832805	40	5	FK	26.3	5912	59.2	13308	0.09	39.6	36.7	6000	9	6.05
7832808-P5	7832809	40	10	FK	64.9	14590	109	24503	0.18	39.6	34	6000	8.3	5.58
7832811-P5	7832812	40	20	FH	52.2	11735	103.6	23289	0.15	39.6	35.2	6000	7.6	5.11
7832814-P5	7832815	40	40	FH	59.7	13421	108.9	24481	0.18	39.6	34	6000	8.4	5.64
7832817-P5	7832818	50	10	FK	66.4	14927	134.3	30191	0.18	49.5	43	6000	13.5	9.07
7832820-P5	7832821	50	20	FH	78.8	17714	188.7	42420	0.16	49.5	44.6	6000	13.6	9.14
7832822-P7†	7832823	63	10	FK	93.8	21086	229.7	51637	0.18	62.5	56.9	6000	22	14.78
7832828-P7†	7832828	63	20	FH	103.1	23177	270.8	60876	0.18	62.5	56.9	6000	22	14.78
7832827-P7†	7832831	80	10	FK	121.9	27404	374.9	84281	0.18	79.5	73.9	6000	36.4	24.6

Note: Accuracy class P-3 or P-5 only.

† T-7 Accuracy only on these units.

## FineLine - Metric

### FK & FH - Standard Flanged Ball Nuts - Clearance & Preload Grade

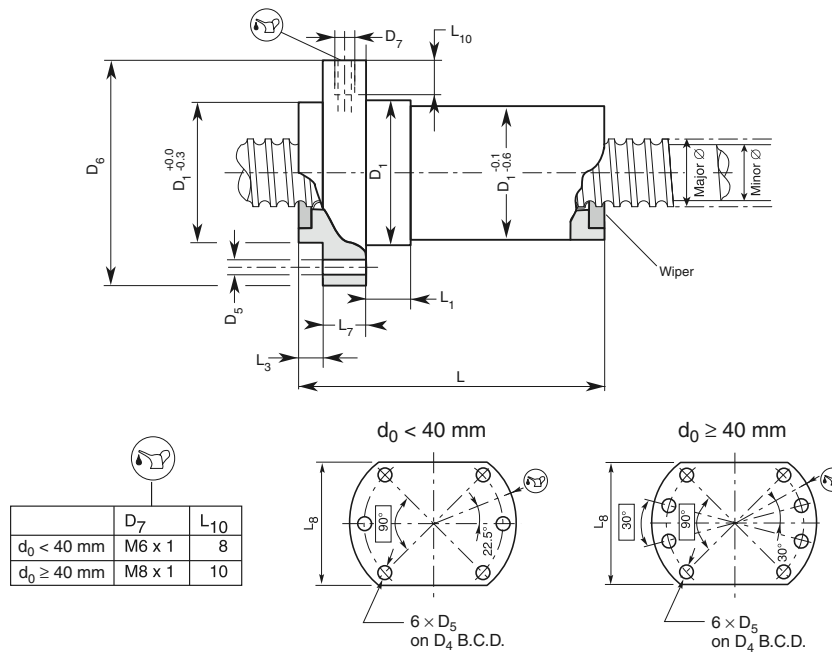

Nom. Diam.	Lead	Nut Type	Nut Dimensions [mm]									Nut Weight		Ball Ø (Dw) [mm]
			D <sub>1</sub>	D <sub>4</sub>	D <sub>5</sub>	D <sub>6</sub>	L	L <sub>1</sub>	L <sub>3</sub>	L <sub>7</sub>	L <sub>8</sub>	[kg/m]	[lb/ft]	
d <sub>0</sub> [mm]	P <sub>h0</sub> [mm]		D <sub>1</sub> g6	D <sub>4</sub>	D <sub>5</sub>	D <sub>6</sub> H12	L ±1	L <sub>1</sub> +2	L <sub>3</sub> -0.5	L <sub>7</sub> H13	L <sub>8</sub> H13			
12	5	FK	25.5	32	4.6	40	14	11	5.5	12	28	0.1	0.22	1.984
16	5	FK	28	38	5.5	48	48.5	10	5.5	10	40	0.25	0.55	3.500
20	5	FK	36	47	6.6	58	48.5	10	5.5	10	44	0.35	0.77	3.500
20	20	FH	36	47	6.6	58	59	20	14	10	44	0.45	0.99	3.500
25	5	FK	40	51	6.6	62	49	10	6	10	48	0.37	0.82	3.500
25	10	FH	40	51	6.6	62	51	9	16	10	48	0.45	0.99	3.500
25	25	FH	40	51	6.6	62	71	20	15.5	10	48	0.55	1.21	3.500
32	5	FK	50	65	9	80	57	10	6	12	62	0.7	1.54	3.500
32	10	FK	50	65	9	80	73	16	6	12	62	0.8	1.76	5.556
32	20	FH	56	71	9	86	83	25	19	22	68	1.4	3.09	5.556
40	5	FK	63	78	9	93	66	10	7	14	70	1.2	2.65	3.500
40	5	FK	63	78	9	93	88.5	16	7	14	70	1.4	3.09	7.144
40	20	FH	63	78	9	93	83	25	19.5	14	70	1.6	3.53	5.556
40	5	FH	70	85	9	100	104	25	21	14	77	2.4	5.29	7.144
50	10	FK	75	93	11	110	92	16	7	16	85	2	4.41	7.144
50	25	FH	75	93	11	110	85	16	22	16	85	2.2	4.85	6.350
63	5	FK	90	108	11	125	103.5	16	7	18	95	3	6.61	7.144
63	10	FH	95	115	13.5	135	86	18	24	20	100	3.8	8.38	7.144
80	20	FK	105	125	13.5	145	121	16	9	20	110	3.9	8.6	7.144

## Precision Plus - Metric P-3 Accuracy



FL Flanged Ball Nut - Precise Preload

### Thomson Precision Plus Metric Ball Screws Assemblies Offer:

- Lead accuracies up to eight times those of conventional ball screws for an immediate improvement in machine performance.
- Zero-lash, preloaded designs available with a high spring rate that provides positioning accuracy and repeatability for machine tools, robots, material handling systems, electronic component insertion systems, and more.
- A gothic arch ball groove geometry to extend service life, and optimize stiffness in preloaded assemblies.
- Maximum lead error
  - P3 -  $12\mu\text{m} / 300\text{mm}$  (.0005"/ft)
- Integral wipers and flanges contributing to system cleanliness and mounting ease.
- Optimum efficiency and cost savings when replacing expensive hydraulic and pneumatic systems.
- Predictable service life for the most reliable, economical system designs.
- Availability through more than 1800 authorized Danaher Motion distributors worldwide.
- Double nut vernier preload (contact factory)

## Precision Plus Metric Product Summary

### Precision Plus Screw Stock

Nominal Dia (mm)	Lead (mm)	Direction	Assembly Part Number	Root Diameter (mm)	Maximum Lengths Available (mm)	Nut/Screw Weight (kg/m)	w/ Mounting Blocks
16	5	RH	7832835	12.70	3000	1.2	7829547
20	5	RH	7832838	16.70	4000	2.0	7829548
25	5	RH	7832841	21.70	5000	3.3	7829549
32	5	RH	7832862	28.70	6000	5.6	7829550
	10	RH	7832844	28.70	6000	5.3	7829550
40	5	RH	7832847	36.70	6000	9.0	7829551
	10	RH	7832850	36.70	6000	8.3	7829551
50	10	RH	7832853	43.80	6000	13.5	7829552
63	10	RH	7832856	56.90	6000	22.0	7829553
80	10	RH	7832859	73.90	6000	36.4	7829553

\* Note: Customer to verify bearings are sufficient for application  
Alternate lengths available on request (consult factory)

## Precision Plus - Metric Product Availability

Lead (in)

Diameter (in)	Lead (in)															
	4	5	6	8	10	12	15	16	20	25	30	32	40	50	60	63
16		●	●													
20		●			●				●							
25		●	●		●	●			●	●						
32		●	●	●	●	●	●		●	●		●				
40		●	●	●	●	●	●	●	●	●		●	●			
50		●	●	●	●	●	●	●	●	●	●		●	●		
63		●	●	●	●	●	●		●	●	●		●		●	●
80		●			●	●	●	●	●	●	●		●	●	●	●
100		●	●		●	●		●	●	●	●		●	●		
125					●			●	●	●	●		●	●		
160									●	●		●				
200									●			●				

● = stocked size, components in partial complete state.  
● = on request

## Accuracy Classes

Accuracy is a measure of how closely a motion system will approach a command position. Perfect accuracy, for example, means that advancing a ball nut a precise amount from a given point on the screw always requires exactly the theoretically predicted number of revolutions.

Accuracies may be specified by users in two ways.

- **Standards** have been developed for simplicity in grouping sets of accuracies. Tolerance classes have been established by ISO/DIN for the purpose of easily describing lead accuracies for ball screws.
- **Absolute terms** may define accuracies such as .0005 in/ft deviation (typically shown as tolerances on a drawing).

FineLine ball screws are produced in two main tolerance classes: T (transport) and P (positioning). Transport grade ball screws are used in applications requiring only coarse movement or those utilizing linear feedback for position location. As such, most transport grade screws are provided with nuts having backlash (T7 grade screws cannot be supplied with preloaded nuts). Precision grade ball screws are used where repeatable positioning within microns is critical, without the use of a linear feedback device.

Differences between P & T grades are highlighted in the graph above. T grade transport screws allow greater cumulative variation over the useful length of the screw. P grade positioning screws contain accumulation of lead error to provide precise positioning over the screw's entire useful length.

Position grade screws are used in applications such as CNC milling machines, medical imaging equipment, and lens grinding devices. In contrast, transport grade screws are used to drive door actuators or assembly line diverter gates.

Allowable Variation Per Tolerance Class

Tolerance Class	Permissible travel variation within 300 mm		Variation within one revolution ( $2\pi$ rad)	
	[ $\mu$ m]	[in.]	[ $\mu$ m]	[in.]
P3	12	.0005	6	.0002
P5	23	.0009	8	.0003
T5	23	.0009	8	.0003
T7	52	.0020	12	.0005

Cumulative Lead Variation Over Usable Length

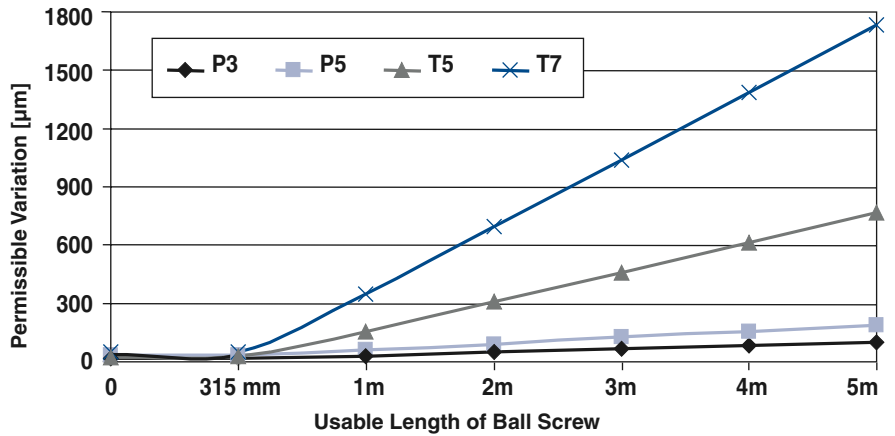

METRIC

## Preload Classes

FineLine Ball Screws are available in three preload classes: Clearance Grade (no preload), Preload (lightly preloaded with four points of contact) and Precise Preload (preloaded with two points of contact to exact customer specifications).

**Precise Preload (Type Z0)**  
(Precisely preloaded to customer specifications)

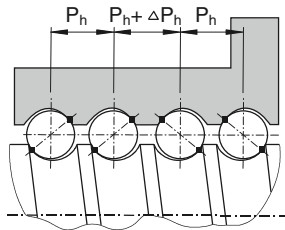

### Precise Preload

The lead is offset by an amount,  $DPh$ , to preload with two points of contact around the balls as shown.

- Offers zero backlash between screw and nut.
- The preload is approximately 10% of dynamic load capacity, but can range from 2% to 13% as specified by customers. Drag torque is controlled within a designated range.
- Typically used for positioning applications where repeatability and high stiffness are required (high stiffness allows for high load carrying with minimum deflection).

(Available only with FL nut.)

**Preload (Type Z1)**  
(Lightly preloaded)

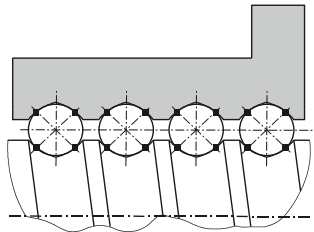

### Preloaded

Oversized balls slightly larger than the ball groove space are used to provide four points of contact.

- Offers zero backlash between screw and nut.
- The preload is approximately 5% of dynamic load capacity.
- Typically used for positioning applications where repeatability is critical.

(Available with FK, FH & ZG style nuts.)

**Clearance Grade (Type Z2)**  
(No preload)

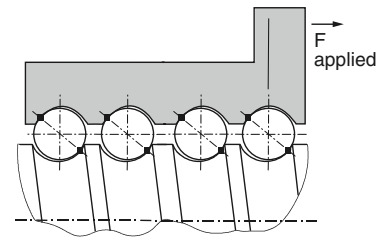

### No Preload

Ball bearings are undersized, thereby creating clearance between the nut and screw.

- Axial play is present between screw and nut, which negatively affects repeatability.
- Introduces no additional drag torque.
- Lead accuracy is unaffected, repeatability is approximately equal to backlash amount. (Typical maximum backlash is .09 to .18 mm, depending on size.)
- Typically used for transport applications or vertical applications where low drag is desirable.

(Available with FK, FH & ZG style nuts.)

## Precision Plus - Metric - (P-3 Class) - 12µm/300mm

FL - Standard Precise Preload Ball Nut - Type ZØ Preload

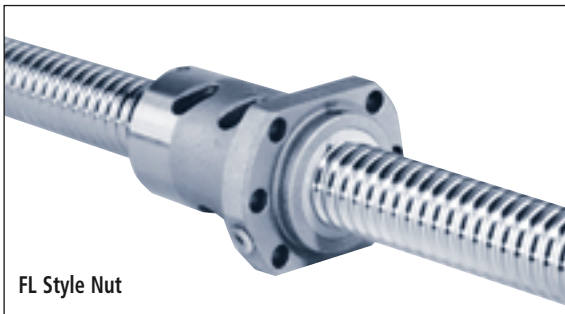

### Flanged Ball Nut and Screw

- Available with precise preload
- Excellent rigidity
- Highest precision

### Performance Specifications for Ball Screws with Flanged Ball Nuts

Ass'y P/N	Nom.		Nut Type	Performance Data					Screw Dimensions						
	Diam.	Lead		Dynamic Load Capacity (C <sub>am</sub> )		Static Load Capacity (C <sub>am</sub> )		Min Stiffness (Cam)	Max Axial Backlash	No. of Loaded	Major Ø	Minor Ø	Max Length	Screw Weight	
	d <sub>0</sub> [mm]	P <sub>ho</sub> [mm]	[kN]	[lbf]	[kN]	[lbf]	[kN/µm]	[mm]	Turns	[mm]	[mm]	[mm]	[kg/m]	[lb/ft]	
7832835	16	5	FL	6.7	1506	7.2	1619	0.16	0.00	2 + 2	15.6	12.7	3000	1.2	0.81
7832838	20	5	FL	11.5	2858	15.5	3484	0.30	0.00	3 + 3	19.6	16.7	4000	2	1.34
7832841	25	5	FL	12.6	2832	19.1	4294	0.38	0.00	3 + 3	24.5	21.7	5000	3.3	2.22
7832862	32	5	FL	19.3	4339	36.4	8183	0.60	0.00	4 + 4	31.6	28.7	6000	5.6	3.76
7832844	32	10	FL	26.4	5935	39	8767	0.49	0.00	3 + 3	31.6	27.1	6000	5.3	3.56
7832847	40	5	FL	26.3	5912	59.2	13308	0.89	0.00	5 + 5	39.6	36.7	6000	9	6.05
7832850	40	10	FL	64.9	14590	109	24503	0.94	0.00	4 + 4	39.6	34	6000	8.3	5.58
7832853	50	10	FL	66.4	14927	134.3	30191	1.18	0.00	5 + 5	49.5	43	6000	13.5	9.07
7832856	63	10	FL	93.8	21086	229.7	51637	1.74	0.00	5 + 5	62.5	56.9	6000	22	14.78
7832859	80	10	FL	121.9	27404	375	84303	2.45	0.00	6 + 6	79.5	73.9	6000	36.4	24.6

Note: FL listed products available in P3 accuracy class only.  
 \* Nut stiffness based on 10% preload (F=10% x C<sub>am</sub>)

Sold only as Assemblies. Contact factory for alternate screw length quote.  
 Alternate sizes and styles available. Contact factory.

Precision Plus - Metric - (P-3 Class)

FL - Standard Precise Preload Ball Nut - Type ZØ Preload

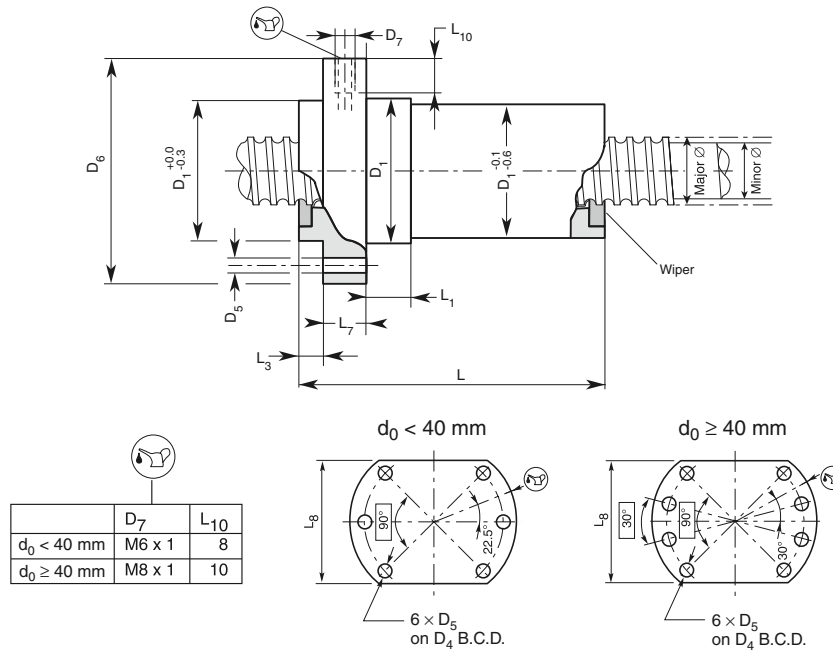

Nom. Diam.	Lead	Nut Type	Nut Dimensions [mm]										Nut Weight		Ball Ø (Dw)
			$D_1$	$D_4$	$D_5$	$D_6$	L	$L_1$	$L_3$	$L_7$	$L_8$	[kg/m]	[lb/ft]		
$d_0$	$P_{ho}$		$D_1$	$D_4$	$D_5$	$D_6$	L	$L_1$	$L_3$	$L_7$	$L_8$	Nut Weight		Ball Ø (Dw)	
[mm]	[mm]		g6			H12	$\pm 1$	+2	-0.5	H13	H13	[kg/m]	[lb/ft]	[mm]	
16	5	FL	28	38	5.5	48	48.5	10	5.5	10	40	0.25	0.55	3.500	
20	5	FL	36	47	6.6	58	48.5	10	5.5	10	44	0.35	0.77	3.500	
25	5	FL	40	51	6.6	62	49	10	6	10	48	0.37	0.82	3.500	
32	5	FL	50	65	9	80	83	10	6	12	62	0.72	1.54	3.500	
32	10	FL	50	65	9	80	105.5	16	6	12	62	0.82	1.59	3.500	
40	5	FL	63	78	9	93	97	10	7	14	70	1.3	2.87	3.500	
40	10	FL	63	78	9	93	142	16	7	14	70	1.5	3.31	7.144	
50	10	FL	75	93	11	110	144	16	7	16	85	2.2	4.85	7.144	
63	10	FL	90	108	11	125	166	16	7	18	95	3.3	7.28	7.144	
80	10	FL	105	125	13.5	145	192	16	9	20	110	4.3	9.48	7.144	



## Quick Mount Bearing Support Blocks - Metric

### Standard

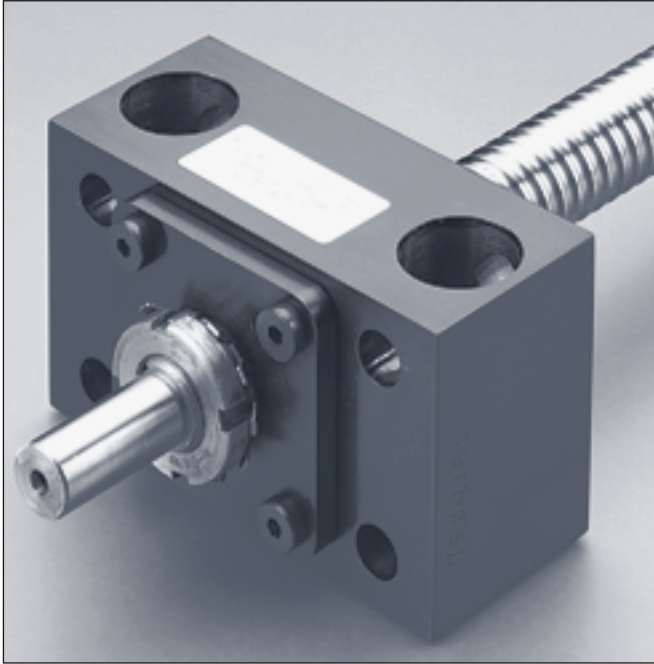

10 Pillow Block configurations have been designed to accommodate the following ball screw sizes.	
Dia. x Lead (mm)	Standard
12 x 5	7829546
12 x 10	7829546
16 x 5	7829547
16 x 10	7829547
16 x 16	7829547
20 x 5	7829548
20 x 10	7829548
20 x 20	7829548
25 x 5	7829549
25 x 10	7829549
25 x 25	7829549
32 x 5	7829550
32 x 10	7829550
32 x 32	7829550
40 x 5	7829551
40 x 10	7829551
40 x 20	7829551
40 x 32	7829551
40 x 40	7829551
40 x 50	7829551
50 x 10	7829552
50 x 50	7829552
63 x 10	7829553
63 x 20	7829553

### A unitized package for simple mounting of Thomson Precision ball screw assemblies.

- Rugged steel construction
- Low profile, compact design
- Foot or face mounting Standard series
- Foot mounting V-Series
- A pre-assembled package ready for installation
- High capacity angular contact bearings arranged in a back-to-back (DB) configuration for high stiffness
- Installation accessories (locknut and washer) included for complete assembly
- Design dimensions fit a standard Type III machined end for ball screws.
- Also available through Bsa Express Machining as a "System" pre-mounted on your ball screw
- The Quick Mount will provide a "simple" bearing support for purposes of critical speed and column strength calculations
- Available off the shelf for your machine building convenience

METRIC

## Quick Mount Bearing Support Blocks - Metric

### Product Dimensions and Specifications

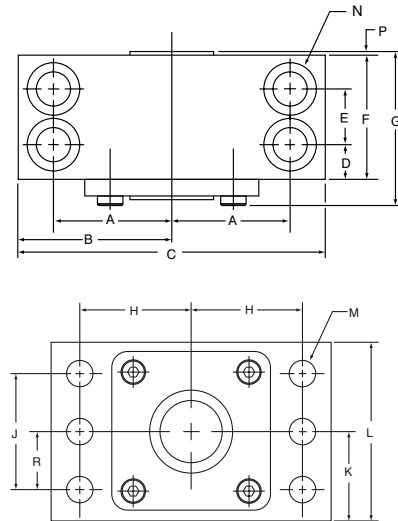
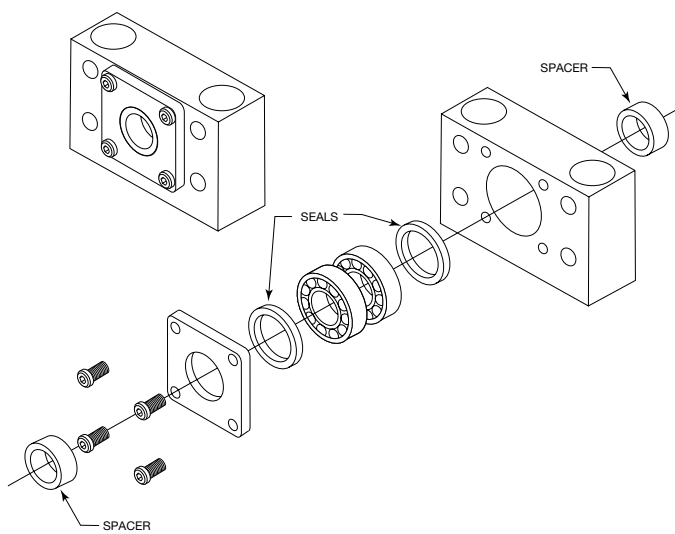

Standard	A	B	C	D	E	F	G	H	J	K	L	M	N	P	R	Locknut
7829546	25.5	35	70	14.25	—	31	35	25.4	35	25.4	51 4 Holes	5.08 Dia. Ø12.5 C-Bore x 14 DP 2 Holes	Ø 8	—	17.53	M8 x 1.25
7829547	28.5	38	76	17	—	34	43	28.58	29	25.4	48 4 Holes	7.14 Dia. Ø 16 C-Bore x 22 DP 2 Holes	Ø 10.3	.5	15.88	KM-01
7829548	31.75	44.5	89	19	—	38	47	31.75	35	28.58	54 4 Holes	7.14 Dia. Ø 16 C-Bore x 25 DP 2 Holes	Ø 10.3	.5	19.05	KM-02
7829549	41.25	57	114	24	—	48	60	41.28	44	36.53	70 4 Holes	10.31 Dia. Ø 25 C-Bore x 33 DP 2 Holes	Ø 16.6	1.0	24	KM-04
7829550	54.0	76	152	24.5	—	49	65	56.26	51	44.45	86 4 Holes	11.91 Ø 35 C-Bore x 50 DP 2 Holes	Ø 23	.75	25.4	KM-05
7829551	60.25	82.5	165	26	—	52	68	60.33	51	47.63	92 4 Holes	16.66 Ø 35 C-Bore x 50 DP 2 Holes	Ø 23	1.0	25.4	KM-06
7829552	74.5	96	192	19.2	41.5	80	96	74.60	76	57.15	108 4 Holes	16.66 Ø 35 C-Bore x 57 DP 4 Holes	Ø 23	1.2	38	KM-08
7829553	90.5	115	230	23.5	43.75	90.75	113	90.506	92	71.45	143 6 Holes	15.24 Ø 41 C-Bore x 9	Ø 26	2.5	46	KM-10

## Thomson Precision Ball Spline Systems

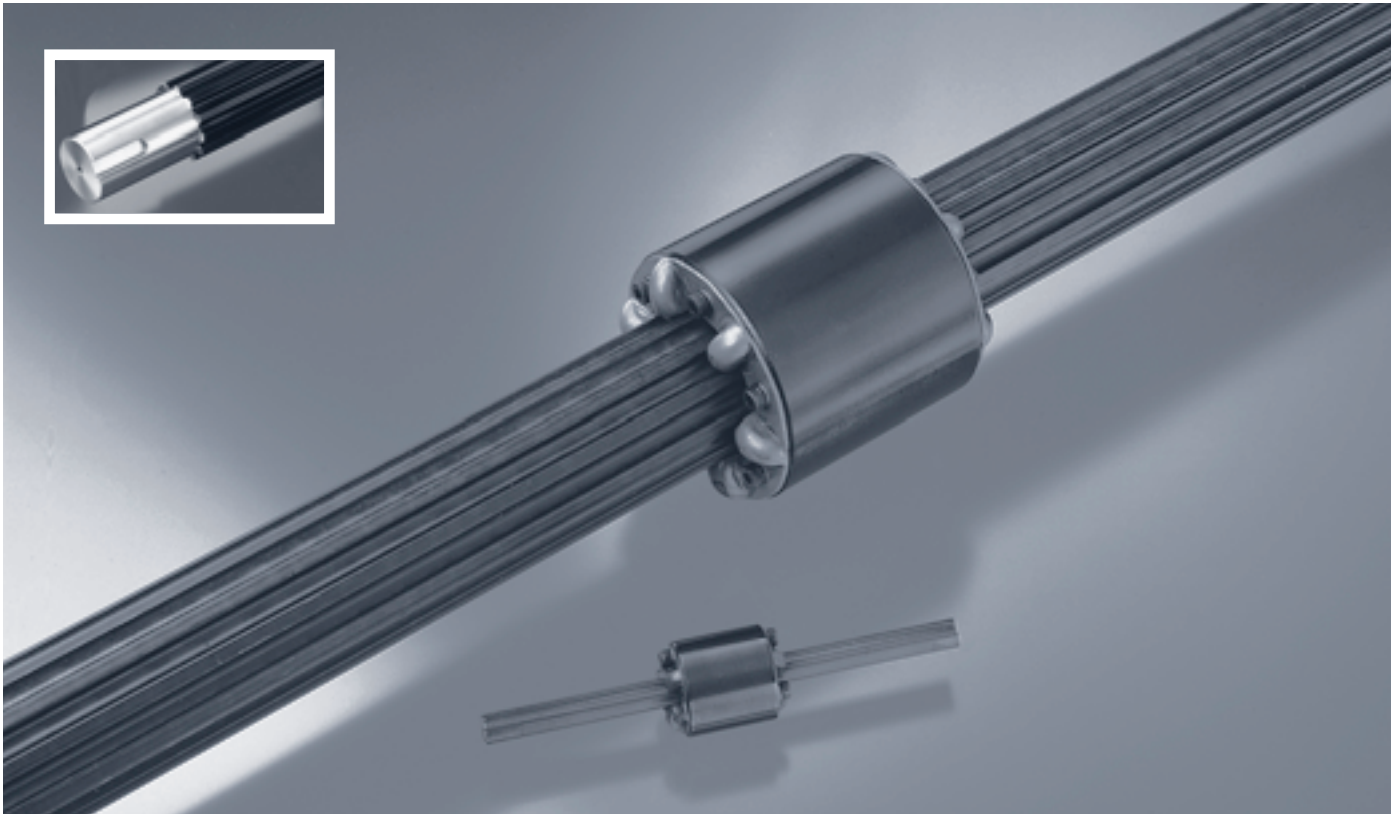

### Thomson Precision Spline Systems Offer:

- High speed, anti-friction linear motion under high torsional loads.
- Anti-friction linear travel by ball recirculation.
- Resistance to radial displacement resulting from torque loads.
- Smaller force requirements to achieve axial displacement of spline members while transmitting torque.
- High reliability under varying operating conditions and predictable life expectancy.
- Minimal lash resulting from wear and elimination of stick-slip.
- Minimized friction reduces heat, thus preventing seizure.
- Custom machined keyways are available on both inner and outer race.
- Application versatility — helicopter rotor coupling; translating drive shaft coupling; non-swiveling telescoping struts; honing machine and drill press spindles; workhead and table ways; robot and remote handling machines.
- Availability through over 1800 authorized Danaher Motion distributors worldwide.

#### Typical Applications

This translating coupling mounts the spline outer race in a keyed and pinned hub for maximum torque loads. The hub is mounted in spaced double bearings. (Hub and bearings not supplied)

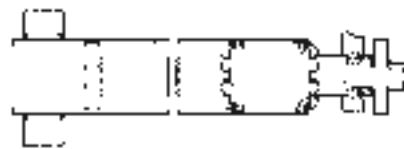

Ball bearing splines are ideal for a translating coupling in high speed applications. Note the use of a follower bearing within the torque tube connected to the spline inner race to provide increased top speed range.

**Thomson Precision Ball Spline Product Summary**  
Precision Screw Stock

Ball Circle	Inner Race P/N	ActiveRaces	Standard Catalog Length (in.)	Root Diameter (in.)	Inner Weight (in.)/IN.	Outer Race P/N	Outer Race w/ keyway	Outer Weight (lb)	Use with these Mounting blocks
.375	5707547	3	24	0.200	0.02	5706900	7828127	0.25	N/A
.625	5707548	3	48	0.425	0.06	5707445	7828128	0.37	7824154
	5707548	6	48	0.425	0.06	5708943	7828129	0.37	7824154
1.000	5706084	3	144	0.800	0.17	5707472	7828130	0.92	7824157
	5706084	6	144	0.800	0.17	5708944	7828131	0.92	7824157
1.500	5706388	3	144	1.230	0.40	5707528	7828132	3.33	7824158
	5706388	6	144	1.230	0.40	5708945	7828133	3.33	7824158
2.000	5706436	3	144	1.670	0.75	5707530	7828134	5.42	7824160
	5706436	6	144	1.670	0.75	5708946	7828135	5.42	7824160
2.500	5706484	3	144	2.100	1.17	5707532	7828136	7.50	7824161
	5706484	6	144	2.100	1.17	5708947	7828137	7.50	7824161
4.062	5702204	6	144	3.660	3.13	5708330	7828138	14.50	N/A
5.000	7825268	8	96	4.470	5.03	7825864	7828139	35.00	N/A
6.000	5704982	8	72	5.470	7.01	5704798	7828140	51.52	N/A

\*Note: Customer to verify bearings are sufficient for application  
Alternate lengths available on request (consult factory).

## General Specifications

A Thomson Precision ball spline system consists of mating inner (SRR) and outer (SOR) races containing concave axial races and a complement of bearing balls. The balls provide the only physical contact between the inner and outer races. Unlimited rolling travel is achieved by diverting the path of the balls at the extremes of the outer race into the end cap return circuit. This provides a closed loop through which the balls recirculate when the races are displaced axially relative to each other. The bearing balls resist radial displacement resulting from torque loads.

- Efficiency — coefficient of friction .007 maximum
- Hardness — minimum of RC 56 in ball race
- Lash — .005 in. maximum standard play perpendicular to rotational axis

### Selection Procedures

**Applications Analysis** — Follow this step-by-step procedure to determine the ball spline best suited for your application. It is suggested you analyze the requirements of your application using a work pad for easy reference.

**Maximum Static Load** — Determine the maximum static torque loads encountered in the application. This must include shock loads. Using the Maximum Static and Rated Loads table, note the ball spline sizes and race combinations which have capacities in excess of the application requirements.

**Rated Load** — In many ball spline applications, freedom of axial movement is essential while actual travel is negligible. For example, a spline used on a jet engine accessory gear box drive moves less than 1/10 in. This axial freedom is essential to eliminate damaging stress forces to the engine and gear box housings, but total daily travel may be less than 2 in. Select the size and race combination with a rated load that will meet your application requirement from the chart.

**Life Expectancy** — On occasion, it is important to plan for a specific life expectancy. These applications usually are designed to use the smallest practical ball spline at the maximum possible torque or where considerable translation occurs. For these applications, use the Life Expectancy chart. Contact Danaher Motion if light weight and small size are considerations.

Determine the following:

- life expectancy — total inches of travel desired during the life of the application
- application load — the normal operating load for the application in inch-pounds (Newton-millimeters) of torque

Using the example at the bottom of the Life Expectancy chart, plot the point for your specific application. Example: Desired life is 2 million in. (50.8 million mm); operating torque is 200 lb.-in. (22.6 N · mm). All ball splines with curves which pass through or are above and to the right of the plotted point are suitable for the example. See page 142.

**Speed vs. Length** — Determine the following:

- Speed — determine the maximum revolutions per minute (rpm) required
- Maximum length — determine the maximum unsupported length
- End fixity — determine the type of configuration (refer to the Bearing Support reference drawings on page 137). Quick Mount bearing support blocks can be used on diameters 5/8 in. through 2-1/2 in. Using the example at the bottom of the Speed vs. Length chart, plot the point for your specific application.

Example: Maximum shaft speed is 800 rpm; unsupported length is 60 in. (1524 mm); end fixity is both ends supported. All ball splines with curves which pass through or are above and to the right of the plotted point are suitable for the example. See page 143.

## Life Expectancy for Precision Ball Spline Systems

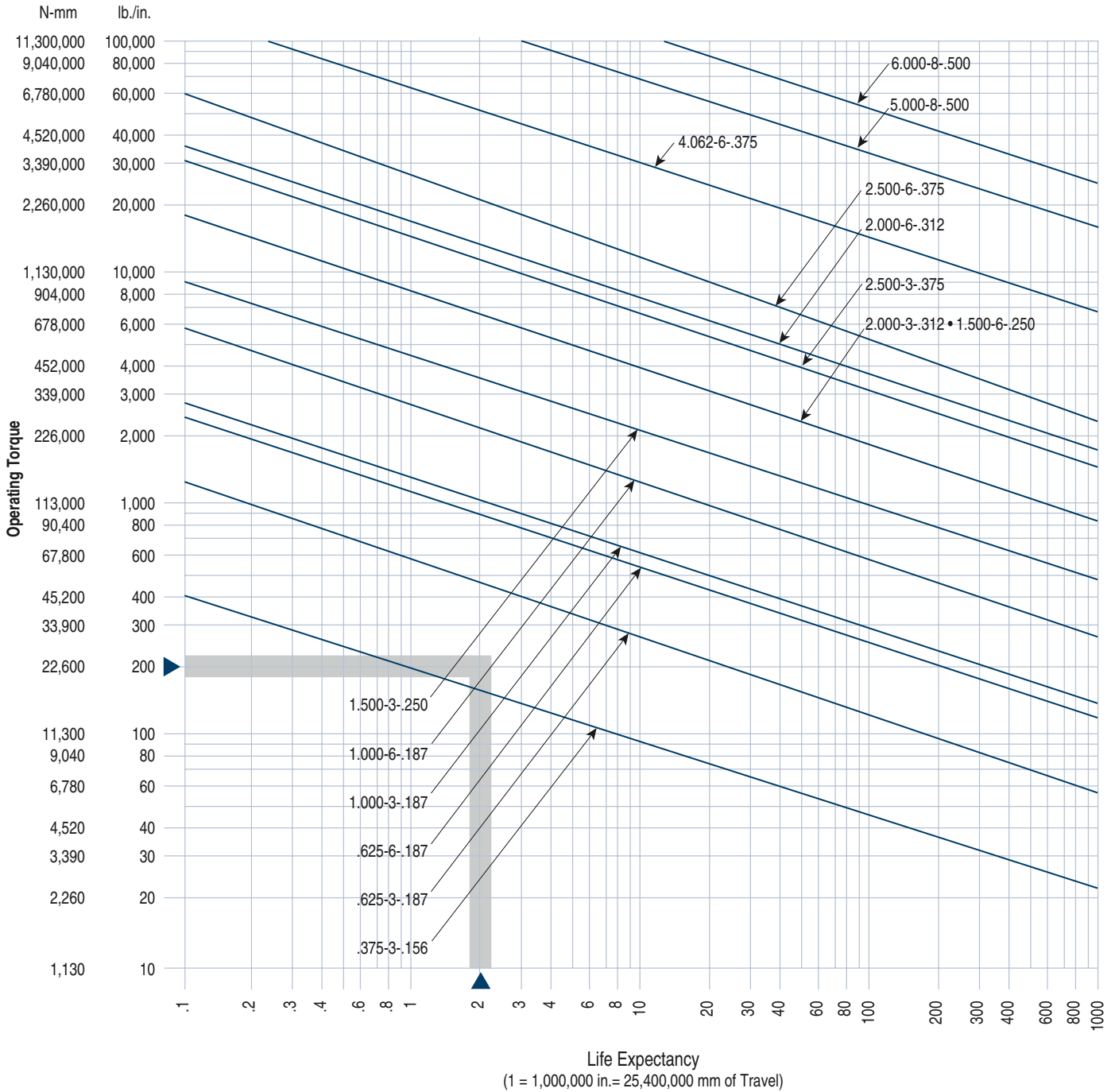

Example: Desired life of 2 million in.  
(50.8 million mm).  
Operating torque is 200 lb.-in.  
(22.6 N · mm)

All splines with curves which pass through or are above and to the right of the plotted point are suitable for the example.

## Speed vs. Length for Precision Ball Spline Systems

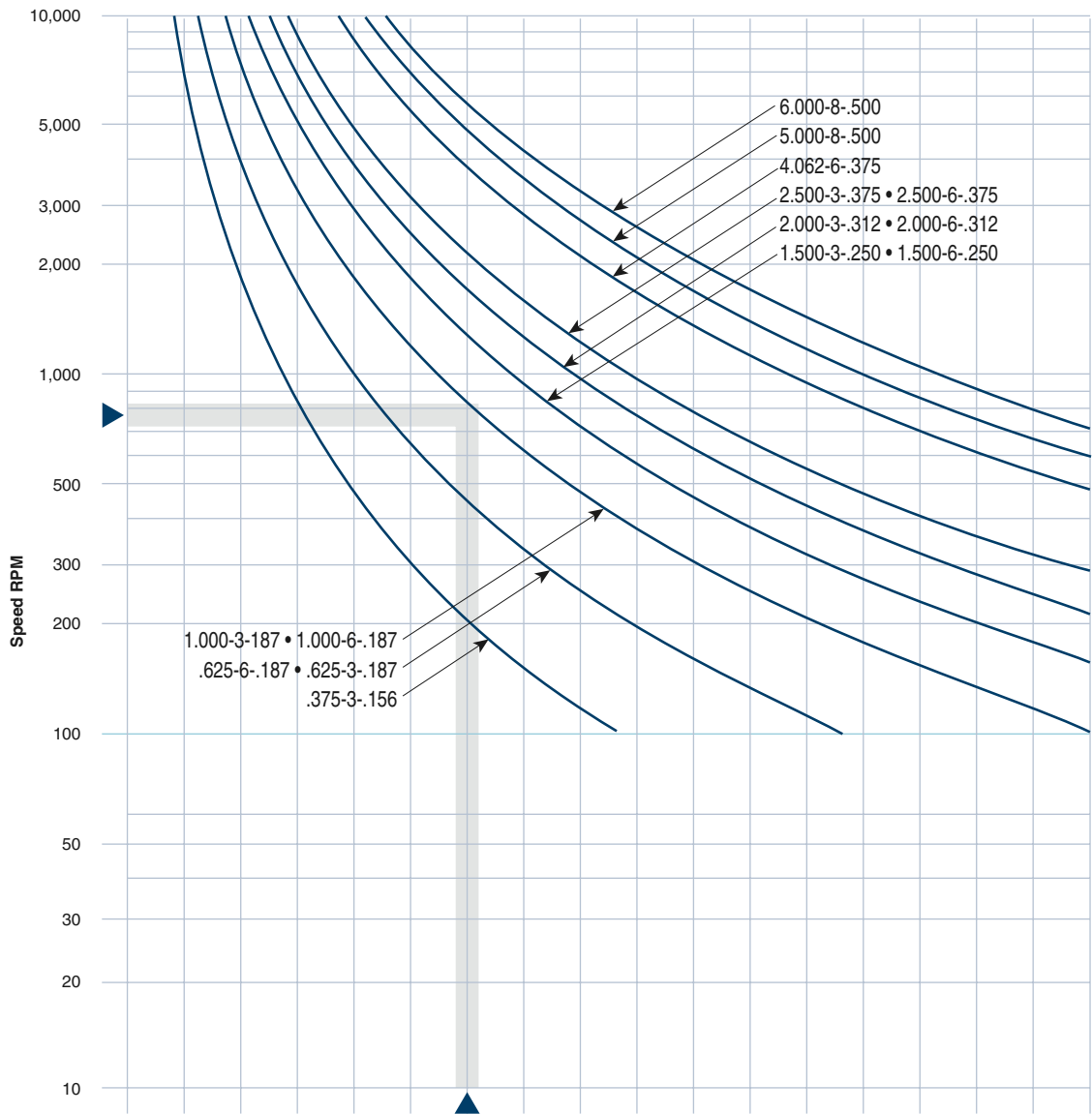

### End Support Type

One end fixed, other end free																			
A	Inches	6	12	18	24	30	36	42	48	54	60	66	72	78	84	90	96	102	
	mm	152	304	457	609	762	914	1056	1219	1371	1524	1676	1828	1981	2133	2286	2438	2590	
Both ends supported																			
B	Inches	10	20	30	40	50	60	70	80	90	100	110	120	130	140	150	160	170	
	mm	254	508	762	1016	1270	1524	1778	2032	2286	2743	2794	3048	3302	3556	3810	4064	4318	
One end fixed, other end supported																			
C	Inches	12	24	36	48	61	73	85	97	109	121	133	145	158	170	182	194	206	
	mm	304	609	914	1219	1549	1854	2159	2463	2768	3073	3378	3683	4013	4318	4622	4927	5232	
Both ends fixed																			
D	Inches	15	30	45	60	75	90	105	119	134	149	164	179	194	209	224	239	254	
	mm	381	762	1143	1524	1905	2286	2667	3022	3403	3784	4165	4546	4927	5308	5689	6070	6451	

Example: Maximum shaft speed is 800 rpm.  
 Unsupported length is 60 in. (1524 mm).  
 End fixity is both ends supported.

All splines with curves which pass through or are above and to the right of the plotted point are suitable for the example.

## Precision (Inner and Outer) Spline Races

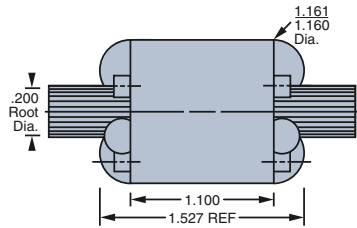

General Description		Inner Race		Outer Race			Load Ratings	
Nominal Size	Active Races	Part Number	Length <sup>†</sup> (ft.)	Part Number	Ball Diameter	Keyway Dimension	Rated Load In in.-lb. for 1-mil. in. (25.4-mil. mm)	Maximum Static Torque Load (lb.-in.)
.375	3	5707547	2	5706900	.156		200	626
.375	3	5707547	2	7828127	.156	.187 x .093 x 1.000	200	626

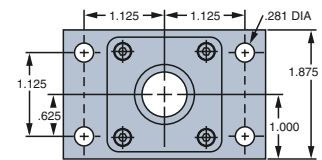
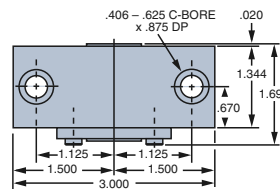
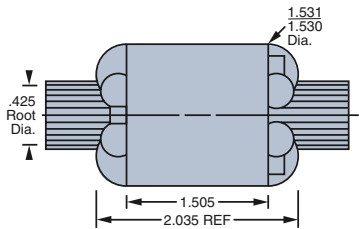

P/N 7824154

General Description		Inner Race		Outer Race			Load Ratings	
Nominal Size	Active Races	Part Number	Length <sup>†</sup> (ft.)	Part Number	Ball Diameter	Keyway Dimension	Rated Load In in.-lb. for 1-mil. in. (25.4-mil. mm)	Maximum Static Torque Load (lb.-in.)
.625	3	5707548	4	5707445	.187		585	1,770
.625	3	5707548	4	7828128	.187	.250 x .125 x 1.125	585	1,770
.625	6	5707548	4	5708943	.187	.250 x .125 x 1.125	1,170	3,540
.625	6	5707548	4	7828129	.187	.250 x .125 x 1.125	1,170	3,540

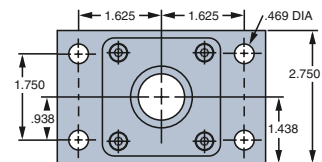
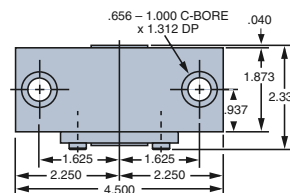
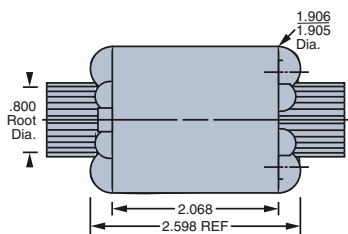

P/N 7824157

General Description		Inner Race		Outer Race			Load Ratings	
Nominal Size	Active Races	Part Number	Length <sup>†</sup> (ft.)	Part Number	Ball Diameter	Keyway Dimension	Rated Load In in.-lb. for 1-mil. in. (25.4-mil. mm)	Maximum Static Torque Load (lb.-in.)
1.000	3	5706084	12	5707472	.187		1,300	3,900
1.000	3	5706084	12	7828130	.187	.250 x .125 x 1.625	1,300	3,900
1.000	6	5706084	12	5708944	.187	.250 x .125 x 1.625	2,600	7,800
1.000	6	5706084	12	7828131	.187	.250 x .125 x 1.625	2,600	7,800



## Precision (Inner and Outer) Spline Races

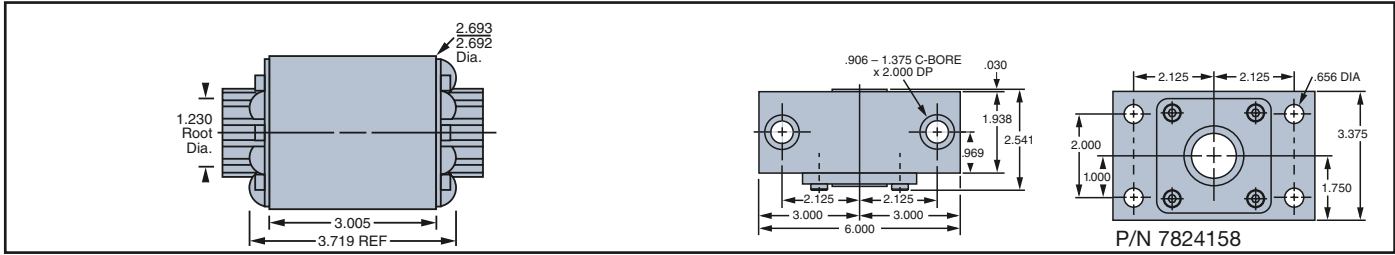

General Description		Inner Race		Outer Race			Load Ratings	
Nominal Size	Active Races	Part Number	Length <sup>†</sup> (ft.)	Part Number	Ball Diameter	Keyway Dimension	Rated Load In in.-lb. for 1-mil. in. (25.4-mil. mm)	Maximum Static Torque Load (lb.-in.)
1.500	3	5706388	12	5707528	.250		4,200	11,588
1.500	3	5706388	12	7828132	.250	.250 x .125 x 2.000	4,200	11,588
1.500	6	5706388	12	5708945	.250		8,400	23,176
1.500	6	5706388	12	7828133	.250	.375 x .187 x 2.000	8,400	23,176

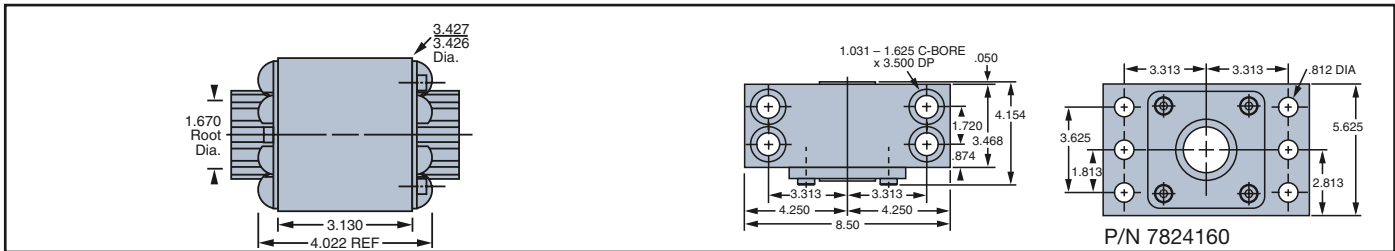

General Description		Inner Race		Outer Race			Load Ratings	
Nominal Size	Active Races	Part Number	Length <sup>†</sup> (ft.)	Part Number	Ball Diameter	Keyway Dimension	Rated Load In in.-lb. for 1-mil. in. (25.4-mil. mm)	Maximum Static Torque Load (lb.-in.)
2.000	3	5706436	12	5707530	.312		8,000	20,138
2.000	3	5706436	12	7828134	.312	.250 x .125 x 2.500	8,000	20,138
2.000	6	5706436	12	5708946	.312		16,000	40,276
2.000	6	5706436	12	7828135	.312	.500 x .219 x 2.500	16,000	40,276

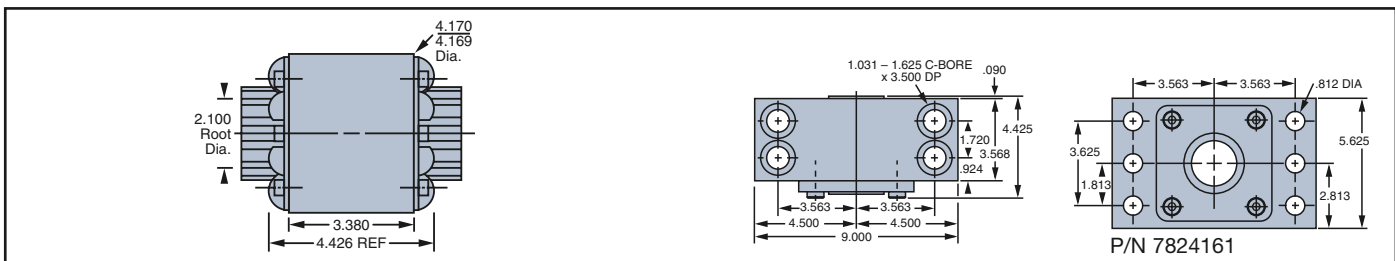

General Description		Inner Race		Outer Race			Load Ratings	
Nominal Size	Active Races	Part Number	Length <sup>†</sup> (ft.)	Part Number	Ball Diameter	Keyway Dimension	Rated Load In in.-lb. for 1-mil. in. (25.4-mil. mm)	Maximum Static Torque Load (lb.-in.)
2.500	3	5706484	12	5707532	.375		13,500	36,625
2.500	3	5706484	12	7828136	.375	.250 x .125 x 3.000	13,500	36,625
2.500	6	5706484	12	5708947	.375		27,000	62,250
2.500	6	5706484	12	7828137	.375	.500 x .250 x 3.000	27,000	62,250

## Precision (Inner and Outer) Spline Races

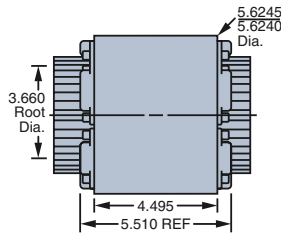

General Description		Inner Race		Outer Race			Load Ratings	
Nominal Size	Active Races	Part Number	Length <sup>1</sup> (ft.)	Part Number	Ball Diameter	Keyway Dimension	Rated Load In in.-lb. for 1-mil. in. (25.4-mil. mm)	Maximum Static Torque Load (lb.-in.)
4.062	6	5702204	12	5708330	.375	1.000 x .500 x 3.500	57,000	140,000
4.062	6	5702204	12	7828138	.375		57,000	140,000

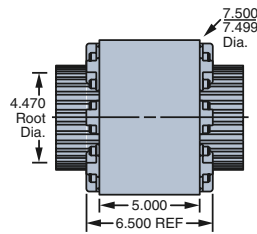

General Description		Inner Race		Outer Race			Load Ratings	
Nominal Size	Active Races	Part Number	Length <sup>1</sup> (ft.)	Part Number	Ball Diameter	Keyway Dimension	Rated Load In in.-lb. for 1-mil. in. (25.4-mil. mm)	Maximum Static Torque Load (lb.-in.)
5.000	8	7825268	8	7825864	.500	1.000 x .500 x 4.500	158,000	345,000
5.000	8	7825268	8	7828139	.500		158,000	345,000

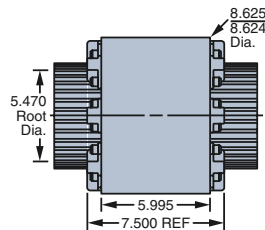

General Description		Inner Race		Outer Race			Load Ratings	
Nominal Size	Active Races	Part Number	Length <sup>1</sup> (ft.)	Part Number	Ball Diameter	Keyway Dimension	Rated Load In in.-lb. for 1-mil. in. (25.4-mil. mm)	Maximum Static Torque Load (lb.-in.)
6.000	8	5704982	6	5704798	.500	1.000 x .500 x 5.500	214,700	584,000
6.000	8	5704982	6	7828140	.500		214,700	584,000

## Lubricant



### Overview

We offer a full complement of lubricants including our low vapor pressure greases for clean room and vacuum application. The TriGel line is specifically formulated to offer a lubrication solution for a wide range of linear motion applications. Choose the appropriate gel for your requirements and get the utmost performance out of your Thomson products.

## Lubrication Selection Chart for Ball & Lead Screw Assemblies

Thomson Gel Type	TriGel-300S	TriGel-450R	TriGel-600SM	TriGel-1200SC	TriGel-1800RC
Application	Acme Screws Supernuts, Plastic Nuts	Ball Screws, Linear Bearing	Bronze Nuts	Acme Plastic Nuts, Clean Room, High Vacuum	Ball Screws, Linear Bearings, Bronze Nuts, Clean Room, Vacuum
Maximum Temperature	200° C (392°F)	125°C (257°F)	125°C (257°F)	250°C (482°F)	125°C (257°F)
Mechanism Materials	Plastic on Plastic or Metal	Metal on Metal	Metal on Metal Bronze on Steel	Plastic or Metals, Combination	Metal on Metal
Mechanical Load	Light	Moderate	Moderate to Heavy	Light to Moderate	Moderate
Very Low Torque Variation over Temperature	Yes	—	—	Yes	—
Very Low Starting Torque	Yes	Yes	—	Yes	Yes
Compatibility with Reactive Chemicals	Not recommended w/o OEM testing	Not recommended w/o OEM testing	Not recommended w/o OEM testing	Usually OK	Not recommended w/o OEM testing
Compatibility with Plastics and Elastomers	May cause silicon rubber seals to swell	May cause EPDM seals to swell	May cause EPDM seals to swell	Usually OK	May cause EPDM seals to swell
Clean Room Use	Not recommended	Not recommended	Not recommended	Usually OK	Usually OK
High Vacuum Use	Not recommended	Not recommended	Not recommended	Usually OK	Usually OK
Vapor Pressure (25°C)	Varies with lot	Varies with lot	Varies with lot	8x10 <sup>-9</sup> torr	4x10 <sup>-9</sup> torr
Packaging 10cc Syringe 1 Pound Tube	TriGel-300S TriGel-300S-1	7832867/TriGel-450R 7832868/TriGel-450R-1	4 oz tube/TriGel-600SM	TriGel-1200SC NA	7832869/TriGel-1800RC

\* Maximum temperature for continuous exposure. Higher surge temperatures may be permissible but should be validated in the actual end use by the OEM. Low temperature limits are -15°C or lower. Consult Danaher Motion for specifics.

## Maintenance and Service

All Thomson ball screw assemblies are designed for maximum life and trouble-free operation when adequately serviced and maintained. Ball screw disassembly should be attempted only after complying with the general inspection and maintenance instructions outlined in this section. Be positive that the ball screw is at fault. Disassembly should be done only by persons familiar with ball screw assembly principles. In any unusual circumstances, contact Thomson.

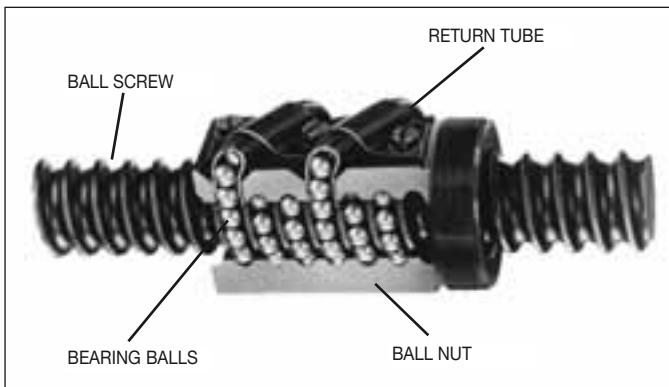

Figure 5

### General Description

A Thomson ball screw is a force and motion transfer device belonging to the family of power transmission screws. It replaces the sliding friction of the conventional power screw with the rolling friction of bearing balls. The balls circulate in hardened steel races formed by concave helical grooves in the screw and nut. All reactive loads between the screw and nut are carried by the balls which provide the only physical contact between these members. (See Figure 5.)

As the screw and the nut rotate relative to each other, the balls are diverted from one end and carried by ball guides to the opposite end of the nut. This recirculation permits unrestricted travel of the nut in relation to the screw.

### Ball Deflectors (Method I)

Ball nuts using the deflector return system are identified by threaded deflector studs extending through holes in the nut and the guide clamp. Lock nuts of the deflector studs are used to secure the clamps that hold the guides in place. (Fig. 6.)

### Pick-up Fingers (Method II)

Ball nuts using pick-up fingers are identified by the finger projections integral with the guide. In this method, cap screw fasteners are used to fasten the clamp that holds the guide in place. (Figure 6.)

### Wipers

Wipers are available for most units as optional items. They generally fall into two categories: one style is internally mounted inside the extreme ends of the ball nut and held in place with retaining rings; the other is a wiper and retainer kit combination mounted on the exterior end of the ball nut. In some applications, one or the other may be used or a combination of both. Visual inspection will reveal the style used.

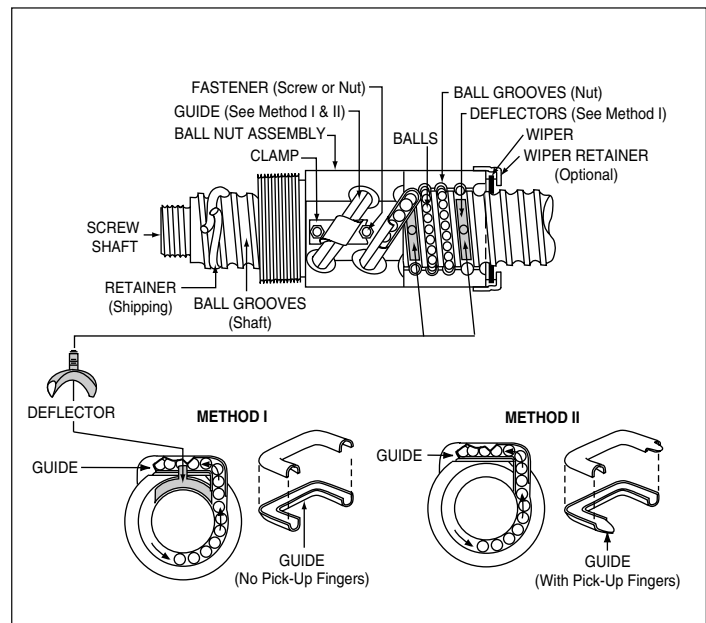

Figure 6

### Troubleshooting

Misalignment is one of the most common problems. Evidence of misalignment can generally be detected by one of the following situations:

- Squealing noise caused by the balls sliding in one or more of the circuits.
- Roughness in the form of vibrations or slightly erratic operation. This can normally be detected by "feel" when placing your hand on the return circuits.
- Excessive heat at the ball nut. Any appreciable temperature above the ambient of adjacent components should be considered excessive.

Gouging or scoring marks on the ball contact area of the screw may be caused by trapped balls between the circuits, broken balls, broken pick-up fingers or deflectors, or foreign objects which may have been digested by the ball nut.

When any of these conditions are encountered, examine the installation and, if necessary, immediately take corrective action to eliminate the cause and prevent further damage.

### General Inspection of the Screw Shaft

Inspect the shaft ball grooves for signs of excessive wear, pitting, gouges, corrosion, or brinelling. Normally, where any of these conditions exist on most Thomson Precision units, it may be more economical and advisable to replace the screw shaft. Consult Thomson for evaluation and possible repair of Precision Plus units.

### Backlash

Secure the screw shaft rigidly in a table clamp or similar device. Make sure it cannot rotate. Push firmly on the ball nut, first in one direction, then in the opposite direction. The axial movement of the ball nut is the backlash. This measurement can be taken with a dial indicator. Make sure that neither member rotates while the readings are taken.

## Maintenance and Service (continued)

Backlash with the following limits is considered acceptable:

Ball Diameter	Max. Permissible <sup>1</sup> Lash (used unit)	Max. Lash (new unit)
0 - 1/8"	.008	.005
5/32" - 1/4"	.014	.007
9/32" - 15/32"	.025	.010
1/2" and up	.050	.015

<sup>1</sup> Values based on wear resulting from foreign material contamination and/or lack of lubrication.

If, after inspection, the screw shaft appears to be usable but has excessive backlash, proceed with further disassembly and component inspection.

### Disassembly

General Instructions: Have a clean container, such as a tote tray or cardboard box, handy for each ball return circuit of the ball nut assembly. A piece of clean cloth should be placed on the work table and gathered around the edge to form a pocket to retain the balls. Place the ball nut assembly over the cloth and remove the clamp.

Where more than one guide is held in place by a single clamp, secure each remaining guide with a strip of tape around the diameter of the ball nut to prevent accidental guide removal before you are ready for that circuit.

Remove both halves of the guide simultaneously to prevent distortion to either half. Catch all the balls from this circuit on the cloth by rotating the screw or ball nut slowly. Place the removed components into a container. Identify the container, the guide, and the circuit of the ball nut so the components can be reassembled in the same circuit from which they were removed. Repeat for each circuit.

**Pick-up Finger Method:** Refer to the Component Inspection section.

**Deflector Method:** To remove the deflectors from the ball nut assembly, remove the ball nut from the screw shaft. The ball nut must be rotated since the deflectors engage loosely in the screw ball grooves and act as a thread. The deflectors now can be removed from the opposite ends of the ball nut so that you can use them for reference during component inspection.

### Component Inspection and Replacement

Balls: If there is more than one circuit in the ball nut, count the balls in each of the separate containers to be sure each has the same number (within a variation of three balls). Check random samples (about 1/4 of the balls for a circuit) for the following:

- True roundness, with a .0001 in. maximum variation.
- Signs of scuffing or fish scaling.
- More than .0001 in. diameter variation between balls of the same circuit.

Where the random sampling shows balls out of round, signs of scuffing or variation of diameter in excess of .0001 in., or short count in any circuit, all balls in the unit must be replaced with a complete set of new balls. Ball kits are available from Thomson.

To ensure proper operation and long life of the serviced assembly, it is imperative that the diameters of all the replacement balls do not vary in excess of .00005 in. If Thomson kits are not used for service, make sure the balls meet the above specification. (Note: Use only chrome alloy steel balls, Grade 25 or better. Carburized balls or carbon steel balls will not provide adequate life.)

**Deflectors:** Examine the ends of the deflectors for wear or brinelling. Wear can be determined by comparison with the unused ends of the two outside deflectors. Since these ends have not been subjected to wear from balls, they are in a like-new condition. Where wear or brinelling is evident, it is best to replace the deflectors with new ones.

**Pick-up Fingers:** Inspect the pick-up fingers, which consist of short extensions at the end of the guides. Replace with new guides if a ball brinell impression appears on the tip. Remove any burrs on the fingers. If the guides were distorted during removal, replace with new guides.

**Ball Nut:** Inspect the internal threads of the ball nut for signs of excessive wear, pitting, gouges, corrosion, spalling, or brinelling in the ball groove area. On large ball nuts, running the tip of your finger along the groove which is accessible will enable you to detect a secondary ridge in the ball groove area when wear is excessive or brinelling has occurred. (The extended lead of a mechanical pencil can also be used as a groove probe.) If inspection indicates any of these flaws, the ball nut assembly should be replaced.

**Wipers:** Prolonged use and environmental conditions will generally determine the condition of wipers. After cleaning wipers, reassemble over the screw shaft to determine whether a snug fit is maintained over the complete contour of the screw shaft. Any loose fitting or worn wipers should be replaced. Wiper kits are available for Thomson ball screws.

Note: If the assemblies have had extended use, it is recommended that all low cost items be replaced with new parts (i.e., balls, guides, deflectors, clamps). These can be ordered by simply referring to the assembly part number purchased.

### Reassembly

Cleaning: Clean all components with a commercial solvent and dry thoroughly before reassembly.

**Deflector Method:** Where the ball nut is equipped with deflectors, install these and secure temporarily by running the lock nuts down the studs and tightening.

General Instructions: Position the ball nut on the screw shaft. Ball nuts with deflectors have to be screwed on. Other ball nuts will slide on. Using dowels with an O.D. approximately equal to the diameter of the balls, center the ball nut grooves with the shaft grooves by inserting dowels into each of the ball nut return circuit holes.

Remove the second dowel from one end. With the ball return holes up, fill the circuit with balls from the container corresponding to that circuit. Turning the screw in the ball nut will help to feed the balls into the groove. When the circuit is full, the balls will begin to lift the end dowel from its position. To be sure there are no voids, lightly tap the top bearing ball and see if the end dowel moves.

The remaining ball in the container should fit into one of the halves of the return guide with space for about three to six left.

Note: There must be some free space in the ball circuit so the balls will roll and not skid. Do not try to add extra balls into the circuit.

Place a dab of bearing grease at each end of the half return guide to hold the balls in place. Now, take the other half of the return guide and place it over the half guide you have filled with balls and insert two ends of the ball guide into the respective hole in the ball nut. Seat by tapping gently with a rawhide or plastic mallet.

Note: Where more than one ball circuit must be filled in the ball nut, tape the ball return circuit to the ball nut to prevent accidental removal. Repeat the filling procedure for the remaining circuits.

With all ball circuits filled and all return guides in place, secure the return guides with the retaining clamp.

Caution: Care should be taken to ensure that balls are not accidentally trapped between circuits in units having pick-up fingers. In deflector units, the deflectors will fill this space.

## Maintenance and Service (continued)

**Inspection:** Wrap tape around the ball grooves at the ends of the screw shaft to prevent the ball nut from rolling off. Now inspect the assembly for free movement of the ball nut along the entire stroke. There should be no binding, squeal, or roughness at any point.

**Reducing Backlash:** Backlash can be reduced by replacing all the balls with a larger size. If the diameters of the bearing balls are increased by .001 in., backlash is decreased by .003 in. (Ball kits are available for these applications.)

### Lubrication:

**Inspection Prior to Lubrication:** All ball screw assemblies should run smoothly throughout the entire stroke. If the torque is not uniform over the entire stroke:

- Visually inspect the screw shaft for accumulations of foreign matter.
- Using cleaning fluid or solvent, remove dirt from the ball grooves. Be sure to flush the ball nut assembly thoroughly.
- Cycle the ball nut along the screw shaft several times. Wipe with a dry, lintless cloth and lubricate immediately.
- If the assembly continues to operate erratically after cleaning, contact Thomson for further instructions.

**Lubrication:** The operating environment primarily determines the frequency and type of lubrication required by ball screws. The screw shaft should be inspected frequently and lubricated as required by the environmental conditions present. Lubricants can vary from instrument grade oil for dirty and heavy-dust environments to a good grade ball bearing grease for protected or clean environments. For most applications, a good 10W30 oil periodically wiped on the screw shaft with a damp cloth or applied by a drip or mist lubricator will suffice.

**CAUTION:** Where the screw is unprotected from airborne dirt, dust, etc., do not leave a heavy film of lubricant on the screw. Keep the screw shaft barely damp with lubricant. Inspect at regular intervals to be certain lubricating film is present. Where the application requires operation at temperatures below 0° F, an instrument grade oil is recommended. Operating environments from 0° F to 180° F will require a good grade 10W30 oil. For assemblies with balls larger than 3/8 in. diameter, MIL G 3278 grease is recommended. Bearing grease is recommended for operating environments at nominally higher temperatures. Again, in unprotected conditions, the lubricant is best applied with a lubricant-dampened cloth, taking care not to leave an excessive film thickness on the screw. Ball screws should never be run dry.

### Transferring a Ball Nut to or from an Arbor

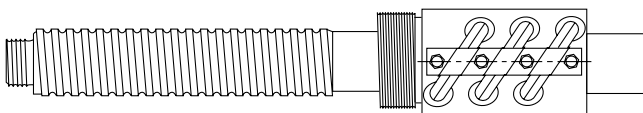

Figure 7

To transfer the ball nut to the screw, proceed as follows:

1. Remove any ball nut retainer from the arbor. Hold the arbor firmly end to end with the screw. Make certain the arbor end is centered on the screw shaft end. (See Figure 7.)

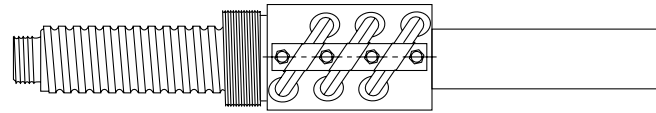

Figure 8

2. Slide the ball nut down to the screw shaft and rotate to the thread until you feel the balls drop into the screw thread. Then rotate with the screw thread until the ball nut completely clears the end of the screw shaft adjacent to the arbor. (Figure 8.)

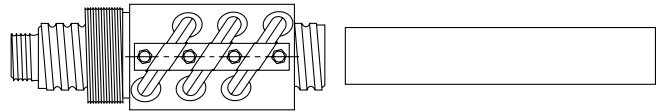

Figure 9

3. Remove the arbor. (Figure 9.)

To transfer the ball nut to the arbor, reverse these steps.

**CAUTION:** When end machining makes it impossible to bring the arbor adjacent to the shaft ball grooves, wrap the machined portion with tape to the nominal O.D. of the arbor. The tape will permit the ball nut to slide over the machined area without the balls dropping into machined irregularities in the shaft. **CAUTION:** Extreme care must be taken to prevent the ball nut from sliding off the end of the screw shaft during installation and handling. Temporary stops can be made by wrapping tape around the shaft ball grooves at each end. Be sure to remove the tape and any residual adhesive after the ball screw assembly is properly installed.

**Warning:** If any balls are spilled during transfer and cannot be recovered and identified, replace all balls using the instructions previously provided in this section.

### Preloaded Ball Screws (Double Nut Design)

**General Description:** The two primary reasons for preloading ball screws are to: eliminate backlash and obtain maximum system stiffness.

Precision ball screws are generally preloaded in any one of the four configurations shown in Figure 10.

Precision ball screw preloading is limited to units having compensating features. However, preload configuration may also be encountered in certain applications approved by our application engineering professionals.

Preload with the solid-type shim is normally established at one-third of the operating load. At this preload level, a nearly constant spring rate is achieved for the assembly up to the operating load. This provides a suitable compromise between stiffness and life expectancy.

Preload for units having a compensating spring feature should be established in excess of the normal operating load whenever possible. Further adjustment is not normally required during the life expectancy. Units of this type are used in many specific applications requiring special considerations. It is advisable to become familiar with the originally intended requirements of such a unit before disassembly.

**Note:** Other styles such as preloading through a housing may be used in custom applications. The same basic instructions outlined in this section apply.

## Maintenance and Service (continued)

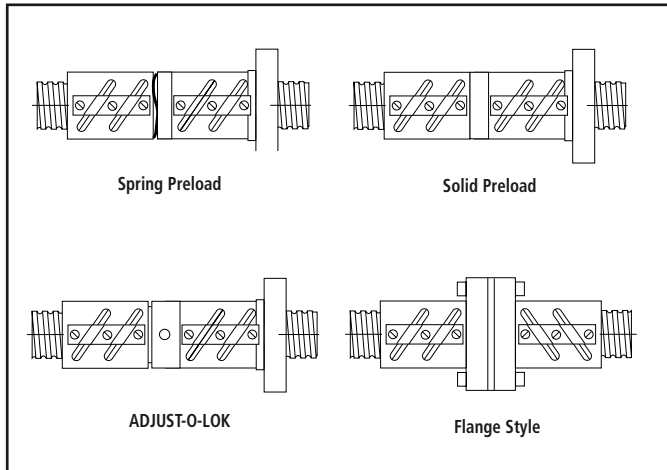

Figure 10

**Inspection and Existing Preload Check:** Whenever possible, the complete ball screw assembly should be removed from the machine prior to a thorough inspection. Preliminary screw inspection can be made while the unit is still in the machine. Preload can be determined by measuring movement of the nut in respect to the screw shaft. Clamp an indicator to the screw shaft with its probe resting on the face of the nut. Apply a load to the machine carriage in both directions. Be sure that the screw cannot rotate or move axially. Any measurable backlash between the ball nut and screw is an indication that preload does not exist. (See Figure 11.)

If no backlash exists, proceed further as outlined to determine whether proper preload remains in the unit. Existing preload,  $W_p$ , can be determined by measuring torque,  $T_p$ , using the following formula:

$$W_p = \frac{T_p}{.007}$$

where:  $W_p$  = Preload force, in lb.  
 $T_p$  = Torque, in lb.-in. (due to preload only)

**Note:** The above check is to determine preload only, and does not take into account torque due to seal drag or operating load.

Torque can be measured by means of a spring scale mounted to any projection on the ball nut or by means of a lever or rod secured to the ball nut. In taking this measurement, be sure the exact lever arm distance is measured. (See Figure 11.) This measurement (in.) multiplied by the scale reading (lb.) equals  $T_p$  (torque lb.-in.). Existing preload can now be determined using the above formula.

Preload adjustment of a Precision ball screw (Figure 10) requires no disassembly. Possible removal of the ball nut from the machine housing may be necessary to expose the adjusting nut.

**Disassembly:** If in doubt about disassembly of preloaded ball nuts, contact Thomson Application Engineering. If the unit is to be disassembled for general repair, follow the steps previously outlined in this section.

If being disassembled for preload adjustment, follow the guidelines except remove only one-half of the ball nut assembly to an arbor. If a standard arbor is not available, one can be made from a piece of shafting or tubing with a diameter approximately .005 in. less than the root diameter of the ball grooves in the screw shaft. Both halves of the ball nut will come apart as soon as the last ball in the nut is free of the grooves in the screw shaft. It is not necessary to remove the other half from the screw.

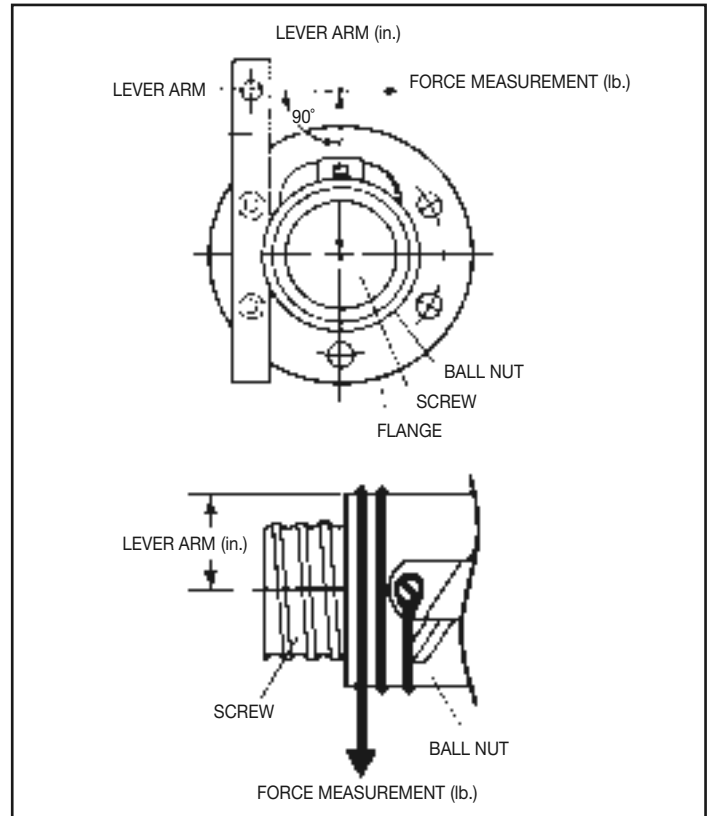

Figure 11

**Preload Adjustment:** The adjusting nut unit in Figure 10 can be adjusted to the desired preload with the use of additional shims. To make further adjustment, loosen the set screw located on the periphery of the lock nut. Use a spanner wrench to rotate the adjusting nut to the desired setting. Recheck the preload.

For all other standard units in Figure 10, a shim increase of .001 in. will, as a general rule, increase preload by 500 to 1,000 lb. This varies depending upon screw size; therefore, some judgement and trial and error may be necessary before the desired preload is achieved.

Preload force,  $W_p$ , can be determined by measuring torque,  $T_p$ , after the desired preload has been established using the following formula:

$$T_p = .007 W_p$$

where:  $T_p$  = torque, lb.-in. (due to preload only)  
 $W_p$  = preload force, lb.

This section is intended to provide basic necessary information to properly service and maintain Thomson ball screws. Other forms of preloaded units may be encountered which have been designed for particular applications.

Please contact Thomson Application Engineering for other specific information.

## Transferring Ball Nuts from Arbor

SBN, SEL and SAR ball nuts are supplied on arbors. Care must be used not to lose any of the bearing balls, or trap balls between circuits when rotating the ball nut onto the screw.

### Preloading SEL and SAR Ball Nuts

SEL and SAR ball nuts are transferred from arbor without a preload. Before preloading these ball nuts, oil the coupling threads, spring washers, ball nut bearing surfaces and the ball grooves of the screw shaft. Center the serrated nut on the coupling.

**Be sure to keep the ball return tubes of the two ball nuts aligned (see drawing). Also, make sure the coupling tangs line up with the slots in the ball nut if they have become disengaged.**

Position the ball nut midway on the screw shaft. Place retainers on screw to prevent the ball nut from accidentally running off the screw shaft. With the ball return tubes facing upwards, tighten the serrated nut against the spring washer "finger tight", plus 1/4 turn. Rotate the screw shaft through several turns in both directions while holding the ball nut with the ball return tubes on top. Continue to tighten the serrated nut with spanner or channel locks until the (.003") (075mm) average gap is obtained resulting in the preload as indicated by the chart. Rotate the screw in both directions several times and check for smoothness. Be sure the spring washer of the coupling is centralized (not protruding in any direction). Use a plastic or brass mallet, if necessary, to help seat the coupling system. Tap lightly. Recheck torque and re-average gap as necessary.

Check the torque by rotating screw shaft with a torque wrench. Secure the serrated nut with the set screw(s) provided.

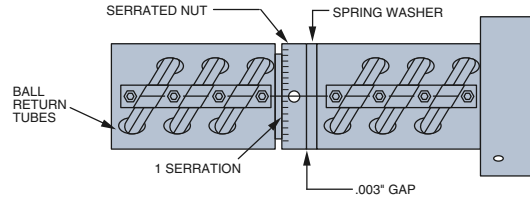

BALL NUT NOMINAL SIZE & LEAD	PRELOAD LBS. (NEWTONS) AT .003" GAP	CHANGE PER* SERRATION LBS. (NEWTONS)	TORQUE IN-LBS, (N-mm) AT .003" GAP
.500 .500 .631 .200	150 (667.5)	20 (89)	1.0 (110)
.750 x .500 .875 .200	220 (979)	20 (89)	1.5 (170)
1.000 .250 1.000 1.00	330 (1468.5)	10 (44.5)	2.0 (230)
1.150 .200	240 (1068)	10 (44.5)	1.5 (170)
1.500 .250	920 (4094)	35 (155.75)	5.5 (620)
1.500 1.000	1550 (7342.5)	20 (89)	10.0 (11.0)
1.500 1.875	1550 (7342.5)	20 (89)	10.0 (11.0)
2.250 .500	5000 (2225)	150 (667.5)	30.0 (3400)
2.500 .250	1300 (5785)	25 (111.25)	10.0 (1100)
3.000 .660	12400 (56180)	55 (244.75)	75.0 (8500)

### Ball Chart Grade 25 Balls or better

SIZE	PART #	NOMINAL DIAMETER	APPROX.# OF BALLS**		
.187 x .050	7821609	0.039	30		
	7821632				
.187 x .062	7821579	0.039	30		
	7821631				
.375 x .125	7824973	0.078	49		
.375 x .125	5709574	0.062	62		
	5709578				
	5709576	0.062	124		
	5707643				
	5707502				
5708282					
.500 x .200	7826763	0.125	72		
	7823871	0.125	48		
	7826720	0.125	96		
.500 x .500	5707506	0.125	60		
	5707644				
	5709582				
	5709584				
	7826767			0.125	120
.631 x .200	7820827	0.125	67		
	7820828				
	5707645				
	7820955			0.125	134
	7823584			0.125	134
.631 x 1.000	7826713	0.125	46		
	7827531	0.125	92		

SIZE	PART #	NOMINAL DIAMETER	APPROX.# OF BALLS**		
.750 x .200	7824297	0.141	134		
	7826768	0.125	72		
	7823870	0.125	108		
.750 x .500	7824358	0.141	134		
	7826991	0.156	268		
.875 x .200	5708277	0.125	184		
	7823585	0.125	184		
1.000 x .250	5707508	0.156	85		
	5707535				
	5700348	0.156	170		
	5708278				
	5708284				
5704167	0.156	170			
5704168					
7823586	0.156	170			
1.000 x .500	7824286	0.156	168		
1.000 x 1.000	5707509	0.156	98		
1.150 x .200	5701566	0.125	224		
	7820207				
	5704270			0.124	224
	7820206			0.124	220
	7823587			0.124	224
1.171 x .413	5707511	0.281	60		

SIZE	PART #	NOMINAL DIAMETER	APPROX.# OF BALLS**		
1.500 x .250	5709587	0.156	230		
	5701990				
	5704270			0.156	460
	7823588			0.156	460
1.500 x .473	5707513	0.344	86		
	5708345				
1.500 x .500	7824246	0.344	122		
1.500 x 1.000	5708280	0.344	64		
	5701995				
	5700698			0.344	128
1.500 x 1.875	5707654	0.281	84		
	5704272	0.281	168		
2.250 x .500	5707516	0.375	154		
	5704000				
	5708346				
	7823589			0.375	308
2.250 x 1.000	5704555	0.375	164		
2.500 x .250	5703243	0.156	468		
	7823590	0.156	936		
2.500 x .500	7824136	0.375	170		
3.000 x .660	5707519	0.5	177		
	5708347				
	5703045			0.5	354
3.000 x 1.500	5704986	0.5	166		
4.000 x 1.000	5703258	0.625	186		
6.000 x 1.000	5704738	0.75	231		

\* Actual ball size is selected during assembly for optimal performance  
\*\* Ball count can vary +/-5%.



## Repair

Danaher Motion has decades of experience in designing and manufacturing ball screws. Our expert engineers and technicians will restore your worn or damaged actuators to original specification, regardless of design or make. Or we can reverse engineer the units to meet new specs. You get:

- Less machine downtime
- Savings of 50-90% compared to new ball screws
- Extended service life
- The same precision as new

### Service

We know how downtime shuts down production. We are geared to keeping your machines up and running smoothly.

We will:

- Inspect and provide a quotation with fast turnaround
- Provide "like new" one-year warranty on all rebuilt assemblies
- Save you money versus the cost of a new ball screw

### Experience

With many years in the ball screw business, our engineers, metallurgists, production specialists and customer service representatives give you the industry's most reliable reconditioning service.

We will check returned units for:

- Straightness
- Ball groove form
- Lead accuracy
- Drunkenness
- Wear
- Metal fatigue
- End machining concentricity, damaged V-threads and worn or damaged bearing and seal journals
- Condition of ball return components
- Condition of wipers and stops
- Condition of flange or housing mounting surfaces

### Capability

We can then:

- Rebuild internal and external assemblies
- Machine and grind ball screws and nuts
- Eutectic build-up of undersized, scored or damaged bearing journals.
- In-house heat-treating, if required
- Plating capability to ASTM or MIL SPECS
- Upgraded wiper technology

### Results

We can chart and document inspection and test results of rebuilt units with:

- Backlash and torque readouts
- Zeiss coordinate measurement system to check ball nut drunkenness
- Laser measurement system (LMS) to check lead error and wobble (drunkenness)
- CAD with Finite Element Analysis capability
- Full metallurgical lab for materials analysis

Then we return the assembly, inspection results and recommended application guidelines, for long service life.

### Special Programs

- On-site services such as field repair, preventative maintenance programs, maintenance training or quick fix field repair kits
- Emergency repair with one-day turnaround
- Scheduled maintenance programs, so you can plan your downtime
- Ball screw repair training seminars
- Extra large sizes, including 12" diameters and extended lengths
- Historical specifications to recondition ball screws dating back to 1941
- Reverse engineering, to meet new specs for increased load capacity, speeds or system stiffness
- Custom-tailored preventive maintenance programs
- Stocks of spare ball screws and components

Our commitment to ball screw reconditioning is one more reason why Danaher Motion is the industry leader in linear actuator technology. If you need expert assistance with ball screw repair, contact our customer service department at 1-800-554-8466.

**Accuracy**

A measurement of precision. Perfect accuracy, for example, means advancing a ball nut 1 in. from any point on a screw will always require the exact same number of revolutions.

**Annealed Ends**

A manufacturing process which removes brittleness while softening screw stock to allow for machining of end journals.

**Axial Lash/Backlash**

The axial free motion between the ball nut and screw; a measure of system stiffness.

**Backdrive**

Application of a force on a ball nut to cause rotation of the screw shaft; in essence, converting linear to rotary motion.

**Ball Circle Diameter**

The distance between the centerlines of two exactly opposing recirculating balls when they are in contact with the screw. The basic point of reference used by Thomson when dealing with ball screws.

**Bearing Ball Circuit**

The closed path of recirculating balls within the ball nut assembly. A multiple circuits has a greater load carrying capability than a single circuit ball nut assembly of the same.

**Compression Load**

Compression load is a load which would tend to compress or buckle the ball screw shaft.

**Conformity Ratio**

Ratio of the ball track radius to the ball diameter.

**Contact Angle**

Nominal angle between a plane perpendicular to the screw and a line drawn between a ball and the ball tracks and projected on a plane passing through the screw axis and the center of the ball. The angle at which the ball contacts the groove.

**Critical Speed**

The condition where the rotary speed of the assembly sets up harmonic vibrations. These vibrations are the result of shaft diameter, unsupported length, type of bearing support, ball nut mounting method, or the shaft or ball nut rpm. Vibrations may also be caused by a bent screw or faulty installation alignment.

**Cycle**

The complete forward and reverse motion of the screw (or nut) when moving the load. One cycle is equivalent to two load carrying strokes (one forward and one backward).

**Diameter - Major**

The outside diameter of the ball bearing screw shaft. In dealing with ball bearing screws, this is the basic measurement.

**Diameter - Major (Root)**

Diameter of the screw measured at the bottom of the ball track.

**Diameter - Pitch**

The nominal diameter of a theoretical cylinder passing through the centers of the balls when they are in contact with the ball bearing screw and ball nut tracks.

**Driving Torque**

The amount of effort, measured in pound-inches, required to turn the ball screw and move the load.

**Dynamic Load Rating**

Dynamic load rating is the maximum load which a ball bearing screw assembly can maintain for a prescribed length of travel.

**Efficiency**

Expressed as a percentage, the ability of a ball screw assembly to convert torque to thrust with minimal mechanical loss. Thomson ball screws operate at over 90% efficiency.

**End Bearing Support (End Fixity)**

The three basic bearing configurations that are commonly used to support the ends of a ball screw are.

a). A single journal or ball type bearing (simple support).

b). A pair of back-to-back, angular contact bearings to control end play (simple support).

c). A pair of spaced bearings for added rigidity (rigid support)

Four combinations of bearing supports are used throughout this catalog for selection purposes.

**Gothic (or Ogival) Groove**

A ball track cross-section shaped like a Gothic arch.

**Lead**

The axial distance a screw travels during one revolution.

**Lead Tolerance**

The maximum variation from nominal, measured in inches per foot, cumulative.

**Linear Expansion**

Ball screw and spline inner races have a coefficient of linear expansion of 0.0000065 for each degree of change (F) and for each inch of race length.

**Load Carrying Balls**

The balls in contact with the ball grooves of both the nut and the screw for load carrying purposes.

**Load/Life Rating**

The usable life of a ball bearing screw assembly measured in inches of travel under a specific load. The length of travel that 90 percent of a group of ball bearing screws will complete, or exceed, before the first evidence of fatigue develops.

**Lubrication**

To provide the maximum useful life, ball splines and ball screws require lubrication. In general, standard ball bearing lubrication practices are acceptable.

### Off Center Load (Eccentric)

A load tending to cock the ball nut on the screw, reducing the rated life. This must be considered in the selection of the ball screw assembly.

### Operating Loads

The normal operating force in pounds (lb.) or Newtons (N) which the ball spline or ball screw will experience is considered the operating load. Contact the Danaher Motion Application Engineering in applications subject to widely fluctuating loads or to optimize design.

### Preload

The use of one group of bearing balls set in opposition to another to remove axial lash or backlash and increase ball bearing screw stiffness. All axial freedom is eliminated in preloading.

### Protective Coatings

Standard outer races are supplied with a black oxide coating. Inner races are furnished with a phosphate coating. Contact Application Engineering for additional options.

### Repeatability

A measurement of constancy. For example, a ball nut traveling between the same established points will always require the exact same number of turns.

### Root Diameter

The diameter of the screw shaft as measured at the bottom of the ball track.

### Screw Diameter (land diameter)

The outside diameter of the screw shaft.

### Screw Starts

The integral number of independent threads on the screw shaft; typically one, two or four.

### Side Load (radial)

A load from the side that will reduce the rated life and must be considered in the selection of the ball bearing screw.

### Spring Rate

A ratio of load versus deflection of a component or of a total system. System stiffness will always be less than its most compliant member. Thus, in any system where a ball screw is used and where high system stiffness is a primary design requirement, Danaher Motion should be contacted for recommendations based on the specifics of the application.

### Static Load

Static load is the maximum non-operating load capacity above which brinelling of the ball track occurs.

### Straightness

The linearity of a screw shaft. Precision screw stock is .010 in./ft. with .040 in. max. Precision Plus stock is typically .003 in. over the entire length of the screw.

### Stroke

The maximum length of extension of a ball nut on the screw shaft.

### Temperature (operating)

With suitable lubricants, ball splines and ball screws will operate with a minimum loss of efficiency between temperatures of -65° to +300°F (-53° to +149°C). Contact Danaher Motion for extreme temperatures.

### Tension Load

Tension load is a load which would tend to stretch the ball screw shaft.

### Thrust Load

Thrust load is loading parallel to and concentric with the centerline of the screw shaft which acts continuously in one direction. Thrust loading is the proper method of attaching the load to the ball bearing screw assembly.

### Travel and Travel Rate

The distance a ball nut moves relative to the screw shaft. Travel rate is the distance traveled in a specific time period.

**Some Useful Formulas for Ball Screw Assemblies**

**Torque, Rotary to Linear**

Driving the screw to translate the nut, or driving the nut to translate the screw.

**Ball Screw Assemblies**  
Torque = .177 x Load x Lead  
(in lbs) (lbs) (inches)

**Lead Screw Assemblies**  
Torque =  $\frac{\text{Load (lbs)} \times \text{Lead (inches)}}{2\pi \times \text{efficiency}^*}$   
(in lbs)

\* Acme screw efficiency is variable with the helix angle of the threads, the friction of the material and the finish. See the efficiency formula below.

**Torque, Linear to Rotary**

Driving the screw to translate the nut, or driving the nut to translate the screw.

**Ball Screw Assemblies**  
Torque = .143 x Load x Lead  
(in lbs) (lbs) (inches)

**Lead Screw Assemblies**  
Torque =  $\frac{\text{Load} \times \text{Lead} \times \text{Efficiency}}{2\pi}$   
(in lbs)

The higher the lead of the screw the less effort required to backdrive either the screw or the nut. As a rule, the lead of the screw should be more than 1/3 the diameter of the screw to satisfactorily backdrive.

**Efficiency**

**Ball Screw Assemblies**  
Most ball screw assemblies are better than 90% efficient.

**Lead Screw Assemblies**  
% Efficiency =  $\frac{\tan(\text{helix angle})}{\tan(\text{helix angle} + \arctan f)} \times 100$   
f = coefficient of friction

**Horsepower**

**Torque to Horsepower**  
HP =  $\frac{\text{Torque (in lbs)} \times \text{RPM}}{63,000}$

**Horsepower to Torque**  
Torque =  $\frac{63,000 \times \text{HP}}{\text{RPM}}$

**Column Load Strength\***

(Based on Eulers Formula)

$$P_{cr} = \frac{14.03 \times 10^6 F_c d^4}{L^2}$$

- P<sub>cr</sub> = maximum loads (lbs)
- F<sub>c</sub> = end support factor
  - .25 one end fixed, other free
  - 1.00 both ends supported
  - 2.00 one end fixed, other supported
  - 4.00 both ends fixed
- d = root diameter of screw (in)
- L = distance between nut and load carrying bearing (in)

When possible, design for tension loads to eliminate the buckling factor and reduce the required screw size

\* Formula only valid if length < dia. ratio ≥ 73.

**Critical Screw Shaft Speed**

(Maximum rotational speed of screw)

$$C_s = F \times 4.76 \times 10^6 \times \frac{d}{L^2}$$

- C<sub>s</sub> = critical speed (rpm)
- d = root diameter of screw (in)
- L = length between supports (in)
- F<sub>c</sub> = end support factor
  - .36 one end fixed, other free
  - 1.00 both ends supported
  - 1.47 one end fixed, other supported
  - 2.23 both ends fixed

Critical shaft speed should be reduced to 80% to allow for other factors such as alignment and straightness

**NOTES:**

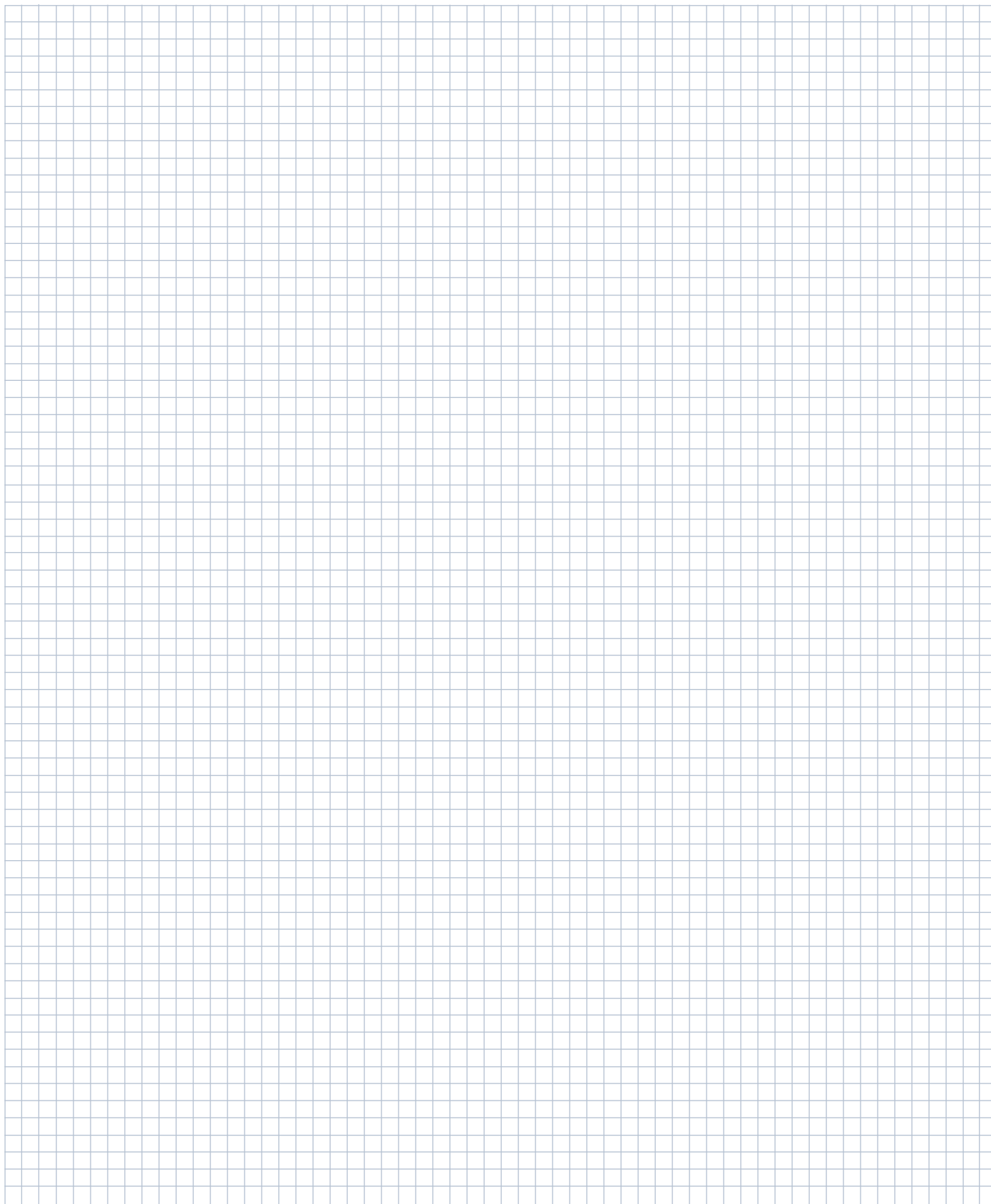

## NOTES:

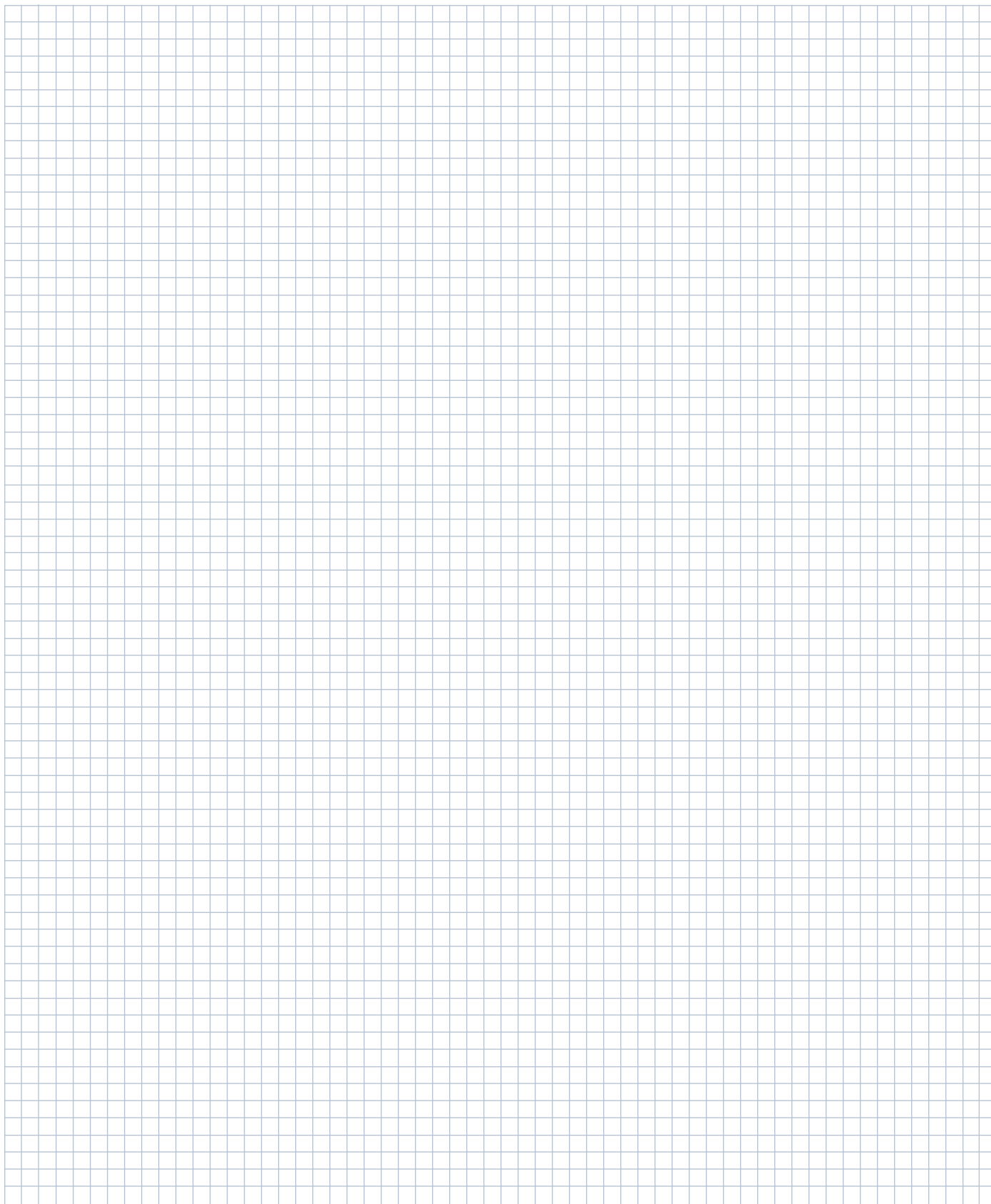
A large grid area for taking notes, consisting of many small squares.

**NOTES:**

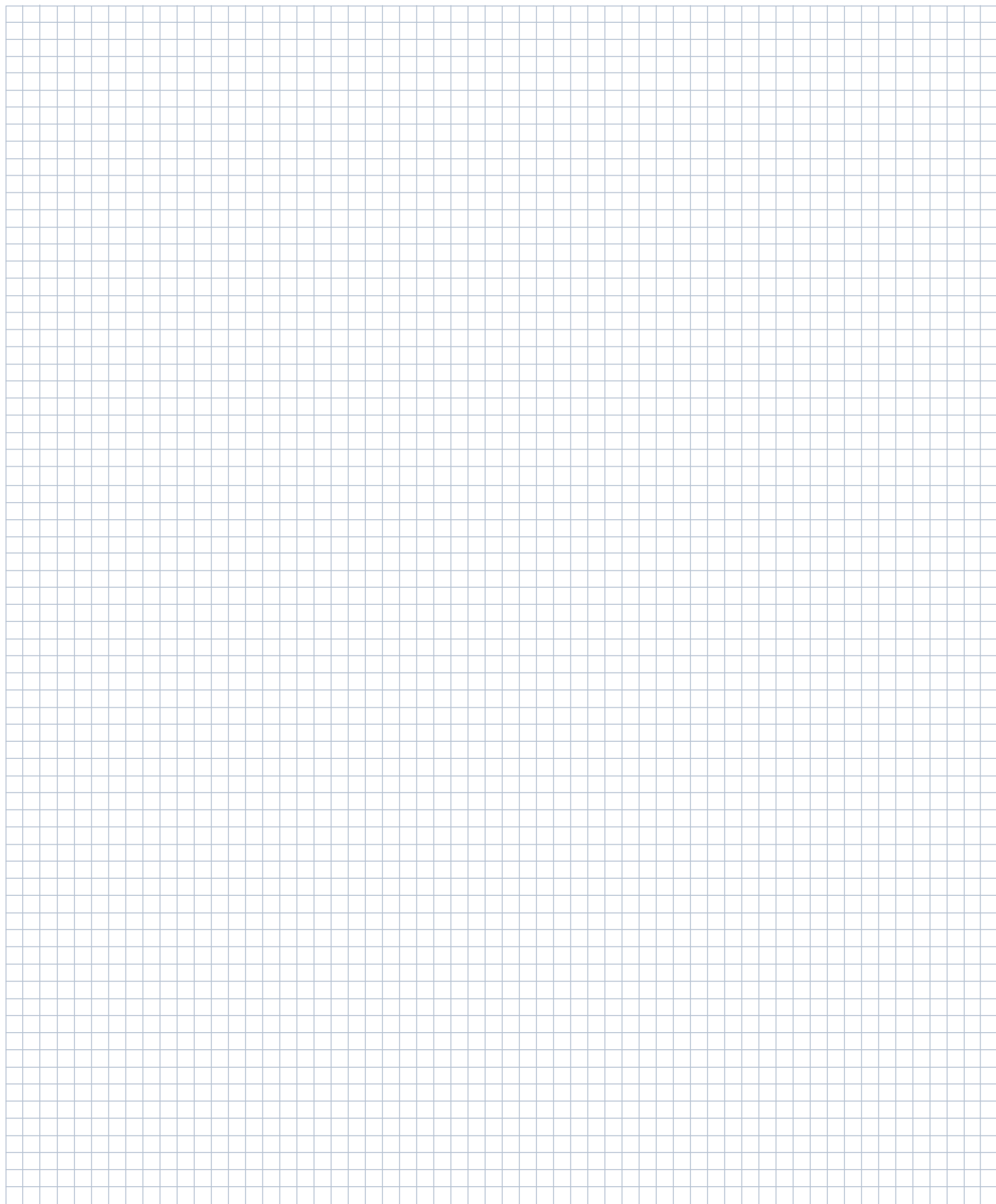

\* Trademark of Danaher Motion. DANAHER MOTION is registered in the U.S. Patent and Trademark Office and in other countries.

# Danaher Motion Linear Motion Systems

As part of the Danaher Motion family, our mechanical and electro-mechanical product offerings include standard and custom linear bearings, shafting, linear guides, ball and lead screws, gearheads, linear actuators, slide tables and systems, precision balls, brakes and clutches, AC and DC adjustable speed drives, stepper and servo motors. Our products are applied worldwide throughout a variety of motion applications in the machine tool, medical, automotive, robotics, industrial, aerospace, office equipment and mobile off-highway markets. Our highly recognized brand names include: Thomson™, Micron™, Deltran PT™, Superior Electric™ and SECO™.



\* Trademark of Danaher Motion. DANAHER MOTION is registered in the U.S. Patent and Trademark Office and in other countries. The specifications in this publication are believed to be accurate and reliable. However, it is the responsibility of the product user to determine the suitability of Thomson products for a specific application. While defective products will be replaced without charge if promptly returned, no liability is assumed beyond such replacement. ©2004 Danaher Motion. RIPON 35K KP 1-22-04 200306-07.qxd BSL-01-01-N101

**FOR IMMEDIATE ASSISTANCE:**

Internet:	<a href="http://www.DanaherLinear.com">www.DanaherLinear.com</a>	In Europe:	Phone:	++46 (0) 44 24 67 00
In USA, Canada or Mexico:	Phone: 1-800-554-8466 Fax: 1-800-445-0329 E-mail: <a href="mailto:linear@danahermotion.com">linear@danahermotion.com</a> Literature: <a href="mailto:litrequest@danahermotion.com">litrequest@danahermotion.com</a>	or write:	Fax:	+46 (0) 44 24 40 85
or write:	Danaher Motion 43-45 Channel Drive Port Washington, NY 11050 USA		E-mail:	<a href="mailto:helpdesk@tollo.com">helpdesk@tollo.com</a>
In UK:	Phone: 0800 975 1000 Sales Fax: 0800 975 1001 E-mail: <a href="mailto:LMSEurope@danahermotion.com">LMSEurope@danahermotion.com</a>	or	Danaher Motion Tollo Linear AB Box 9053 SE-291 09 Kristianstad Sweden	
or write:	Danaher Linear Motion Systems Fishleigh Road, Roundswell Business Park Barnstaple EX31 3UD UK	or write:	Phone:	+49 (0) 70 22 504-0
Catalogue request:	<a href="mailto:catalogues@danahermotion.com">catalogues@danahermotion.com</a>		Fax:	+49 (0) 70 22 541-68
		Elsewhere:	Phone:	1 (516) 883-8937
			Fax:	1 (516) 883-7109