

## *Linear Guides*

*Undriven Building Blocks for Customized Applications  
&  
Ball Screw Assemblies for Actuation of Linear Guides in Custom Applications*

## End Support 1BA

End Supported,  
Industry Standard Dimension  
Inch

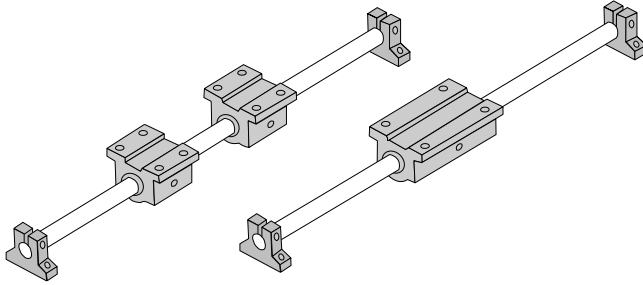

### Features

- Requires only one part number to specify entire linear guide.
- Available with 60 Case\* LinearRace\* Shaft end support blocks in either light weight aluminum or rigid iron materials
- Used to provide increased stability or torque resistance in linear system applications

### Components

- 2 Super Smart Ball Bushing\* pillow blocks or 1 Super Smart Ball Bushing twin pillow block.
- 1 60 Case\* LinearRace\* shaft
- 2 shaft end support blocks

### Specifying this Thomson Linear Guide:

1. Determine the proper Linear Guide for your load and life requirements.
2. Select the part number.
3. Add the letter "L" followed by the overall length in inches, as a suffix to the part number.

### Part Numbering System

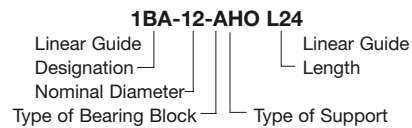

### Dimensions (Inch)

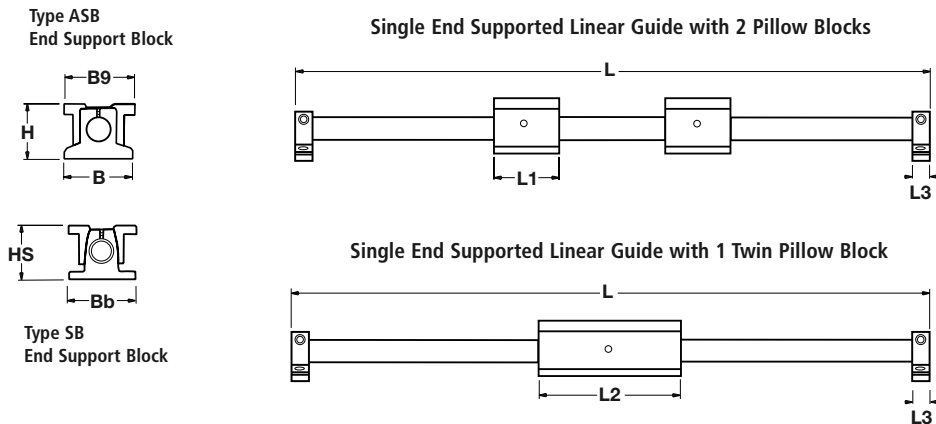

Type SSUPB Super Smart Ball Bushing Pillow Block  
Type SPB Super Ball Bushing Pillow Block

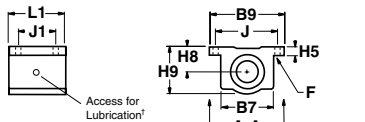

Type SSUTWN Super Smart Ball Bushing Twin Pillow Block

Type TWN Super Ball Bushing Twin Pillow Block

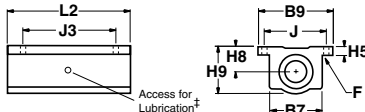

#### ALUMINUM

Type ASB LinearRace Shaft End Support Block

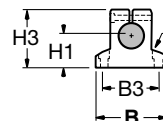

#### STEEL

Type SB LinearRace Shaft End Support Block

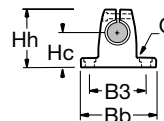

Type SPB Super Ball Bushing Pillow Block  
Mounting Hole Position for Sizes .250 and .375

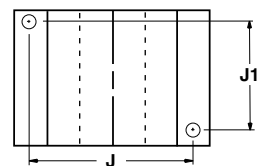

View A-A

‡ Sizes .250, .375 and .500 have oil lubricant fitting.  
Sizes .625 and above have 1/4-28 access for lubrication.

End Support Linear Guide 1BA with 2 Pillow Blocks											(Dimensions in inches)		
Part Number		Nominal Diameter	L1	L3	H	HS	B	Bb	B9	Pillow Block	Shaft Support		
W/ Type ASB Shaft Supports	W/ Type SB Shaft Supports										Type ASB	Type SB	
1BA-04-AHO	-	.250	1.19	.50	.937	-	1.50	-	1.63	SPB-4-XS	ASB-4-XS	-	
1BA-06-AHO	-	.375	1.31	.56	1.062	-	1.63	-	1.75	SPB-6-XS	ASB-6-XS	-	
1BA-08-AHO	1BA-08-AJO	.500	1.69	.63	1.562	1.687	2.00	2.00	2.00	SSUPB-8-XS	ASB-8-XS	SB-8-XS	
1BA-12-AHO	1BA-12-AJO	.750	2.06	.75	2.062	2.187	2.50	2.75	2.75	SSUPB-12-XS	ASB-12-XS	SB-12-XS	
1BA-16-AHO	1BA-16-AJO	1.000	2.81	1.00	2.562	2.687	3.25	3.25	3.25	SSUPB-16-XS	ASB-16-XS	SB-16-XS	
-	1BA-20-AJO	1.250	3.63	1.13	-	3.250	-	-	4.00	SSUPB-20-XS	-	SB-20-XS	
1BA-24-AHO	1BA-24-AJO	1.500	4.00	1.25	3.750	3.750	4.75	4.75	4.75	SSUPB-24-XS	ASB-24-XS	SB-24-XS	

End Support Linear Guide 1BA with 1 Twin Pillow Block											(Dimensions in inches)		
Part Number		Nom. Dia.	L2	L3	H	HS	B	Bb	B9	Max. Stroke Length	Pillow Block	Shaft Support	
W/ Type ASB Shaft Supports	W/ Type SB Shaft Supports											Type ASB	Type SB
1BA-04-BHO	-	.250	2.50	.50	.937	-	1.50	-	1.63	L-(3.50)	TWN-4-XS	ASB-4-XS	-
1BA-06-BHO	-	.375	2.75	.56	1.062	-	1.63	-	1.75	L-(3.88)	TWN-6-XS	ASB-6-XS	-
1BA-08-BHO	1BA-08-BJO	.500	3.50	.63	1.562	1.687	2.00	2.00	2.00	L-(4.75)	SSUTWN-8-XS	ASB-8-XS	SB-8-XS
1BA-12-BHO	1BA-12-BJO	.750	4.50	.75	2.062	2.187	2.50	2.75	2.50	L-(6.00)	SSUTWN-12-XS	ASB-12-XS	SB-12-XS
1BA-16-BHO	1BA-16-BJO	1.000	6.00	1.00	2.562	2.687	3.25	3.25	3.25	L-(8.00)	SSUTWN-16-XS	ASB-16-XS	SB-16-XS
-	1BA-20-BJO	1.250	7.50	1.13	-	3.250	-	4.00	4.00	L-(9.75)	SSUTWN-20-XS	-	SB-20-XS
1BA-24-BHO	1BA-24-BJO	1.500	9.00	1.25	3.750	3.750	4.75	4.75	4.75	L-(11.50)	SSUTWN-24-XS	ASB-24-XS	SB-24-XS

Shaft Deflection Note: Load limit may be below the dynamic load rating due to shaft deflection. Bearings can accommodate up to 1/2° deflection. See Engineering Section (pg B-67) for Deflection calculations.

Dynamic Load Capacity Matrix (4 million inches travel)			
Linear Guide Assembly Part No.	Dynamic Load Capacity (lbf) (Even Distribution)	Pillow Block Part No.	Pillow Block Dynamic Load Capacity (lbf)
1BA-04-AHO	100	SPB-4-XS	50
1BA-06-AHO	160	SPB-6-XS	80
1BA-08-AHO	800	SSUPB-8-XS	400
1BA-12-AHO	1800	SSUPB-12-XS	900
1BA-16-AHO	3000	SSUPB-16-XS	1500
-	3730	SSUPB-20-XS	1865
1BA-24-AHO	6160	SSUPB-24-XS	3080

Dynamic Load Capacity Matrix (4 million inches travel)			
Linear Guide Assembly Part No.	Dynamic Load Capacity (lbf) (Even Distribution)	Pillow Block Part No.	Pillow Block Dynamic Load Capacity (lbf)
1BA-04-BHO	100	TWN-4-XS	100
1BA-06-BHO	160	TWN-6-XS	160
1BA-08-BHO	800	SSUTWN-8-XS	800
1BA-12-BHO	1800	SSUTWN-12-XS	1800
1BA-16-BHO	3000	SSUTWN-16-XS	3020
-	3730	SSUTWN-20-XS	1865
1BA-24-BHO	6160	SSUTWN-24-XS	6160

† Super Ball Bushing\* bearings are used in .250 and .375 inch size pillow blocks.

### Replacement Component Dimensions

Type SPB and SSUPB Pillow Blocks (Dimensions in Inches)											Type TWN and SSUTWN Pillow Blocks						
Part Number	Nom. Dia.	L1	H9	H8	H5	B9	B7	J	J1	F		Wt. lb	Part Number	Nom. Dia.	L2	J3	Wt. lb
										Bolt	Hole						
SPB-4-XS	.250	1.19	.81	.437	.19	1.63	1.00	1.31	.75 <sup>(2)</sup>	#6	.16	.10	TWN-4-XS	.250	2.50	2.00	.19
SPB-6-XS	.375	1.31	.94	.500	.19	1.75	1.12	1.44	.88 <sup>(2)</sup>	#6	.16	.13	TWN-6-XS	.375	2.75	2.25	.25
SSUPB-8-XS	.500	1.69	1.25	.687	.25	2.00	1.38	1.69	1.00	#6	.16	.20	SSUTWN-8-XS	.500	3.50	2.50	.40
SSUPB-12-XS	.750	2.06	1.75	.937	.31	2.75	1.88	2.38	1.25	#8	.19	.62	SSUTWN-12-XS	.750	4.50	3.50	1.24
SSUPB-16-XS	1.000	2.81	2.19	1.187	.38	3.25	2.38	2.88	1.75	#10	.22	1.24	SSUTWN-16-XS	1.000	6.00	4.50	2.48
SSUPB-20-XS	1.250	3.63	2.81	1.500	.43	4.00	3.00	3.50	2.00	#10	.22	2.57	SSUTWN-20-XS	1.250	7.50	5.50	5.14
SSUPB-24-XS	1.500	4.00	3.25	1.750	.50	4.75	3.50	4.12	2.50	1/4	.28	3.94	SSUTWN-24-XS	1.500	9.00	6.50	8.08

Housing Material: Aluminum Alloy Black Anodized (2) Two mounting holes as shown in view A-A for sizes .250 and .375. Top plates are sold separately. Please refer to page B-60 under Accessories for P/N and dimensions.

Housing Material: Aluminum Alloy Black Anodized

Type ASB LinearRace Shaft End Support Block										Type SB LinearRace Shaft End Support Block									
Part Number	Nom. Dia.	L3	H3	H1	B	B3	G		Wt. lb	Part Number	Nom. Dia.	L3	Hh	Hc	Bb	B3	G		Wt. lb
							Bolt	Hole									Bolt	Hole	
ASB-04-XS	.250	.50	.88	.500	1.50	1.12	#6	.16	.06	SB-8-XS	.500	.63	1.62	1.000	2.00	1.50	#8	.19	.3
ASB-06-XS	.375	.56	1.00	.562	1.62	1.25	#6	.16	.08	SB-12-XS	.750	.75	2.12	1.250	2.75	2.00	#10	.22	.5
ASB-08-XS	.500	.63	1.48	.875	2.00	1.50	#8	.19	.11	SB-16-XS	1.000	1.00	2.56	1.500	3.25	2.50	1/4	.28	1.0
ASB-12-XS	.750	.75	1.95	1.125	2.50	2.00	#10	.22	.22	SB-20-XS	1.250	1.13	3.00	1.750	4.00	3.00	5/16	.34	2.0
ASB-16-XS	1.000	1.00	2.48	1.375	3.25	2.50	1/4	.28	.44	SB-24-XS	1.500	1.25	3.50	2.000	4.75	3.50	5/16	.34	2.6
ASB-24-XS	1.500	1.250	3.50	2.000	4.75	3.50	5/16	.34	1.16	Material: Iron									

End Support Material: Aluminum Alloy Black Anodized



©2003 Danaher Motion. Printed in the U.S.A. The specifications in this publication are believed to be accurate and reliable. However, it is the responsibility of the product user to determine the suitability of Thomson products for a specific application. While defective products will be replaced without charge if promptly returned, no liability is assumed beyond such replacement.

## End Support 1NA

End Supported,  
Industry Standard Dimension  
Metric

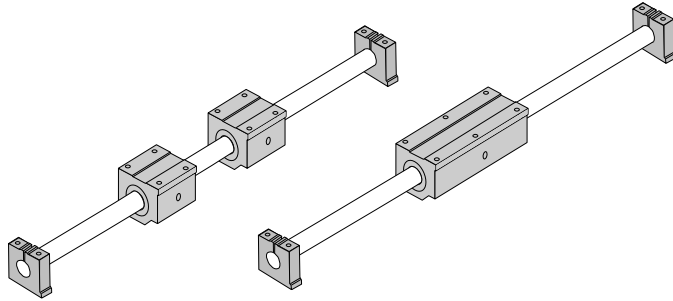

### Features

- Requires only one part number to specify entire linear guide.
- Available with 60 Case\* LinearRace\* Shaft end support blocks in either light weight aluminum or rigid iron materials
- Used to provide increased stability or torque resistance in linear system applications

### Components

- 2 Super Smart Ball Bushing\* pillow blocks or 1 Super Smart Ball Bushing twin pillow block.
- 1 60 Case\* LinearRace\* shaft
- 2 shaft end support blocks

### Specifying this Thomson Linear Guide:

1. Determine the proper Linear Guide for your load and life requirements.
2. Select the part number.
3. Add the letter "L" followed by the overall length in inches, as a suffix to the part number.

### Part Numbering System

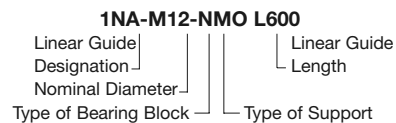

### Dimensions (Metric)

Type ASB  
End Support Block

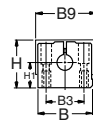

Supported Linear Guide with  
2 Pillow Blocks

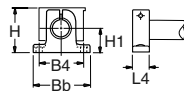
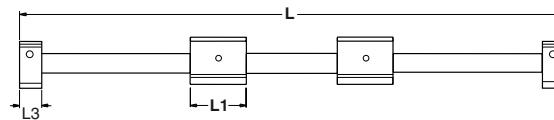

Type SB  
End Support Block

Supported Linear Guide with  
1 Twin Pillow Block

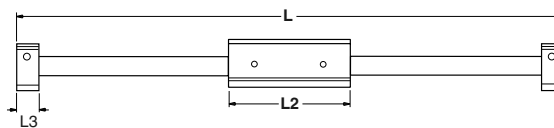

Maximum Stroke Length is determined by subtracting pillow block length (L2) and 2x support block length (L3) or (L4) from total Linear Guide length (L).

Type SPPB Super Plus Ball Bushing Pillow Block  
Type SSEPB Super Smart Ball Bushing Pillow Block

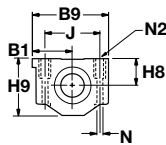
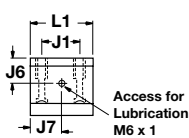

ALUMINUM  
Type ASB LinearRace Shaft End Support Block

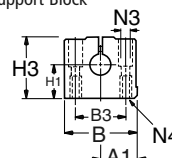

STEEL  
Type SB LinearRace Shaft End Support Block

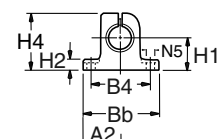

Type SPTWN Super Plus Ball Bushing Twin Pillow Block Type SSETWN Super Smart Ball Bushing Twin Pillow Block

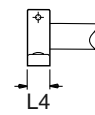
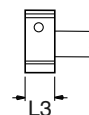
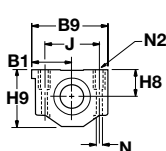
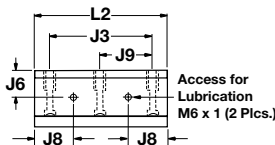

End Support Linear Guide 1NA with 2 Pillow Blocks												(Dimensions in mm)		
Part Number		Nom. Dia.	L1	L3	L4	H	H1	B	Bb	B9	Pillow Block	Shaft Support		
W/ Type ASB Shaft Supports	W/ Type SB Shaft Supports											Type ASB	Type SB	
1NA-M08-NMO	1NA-M08-NNO	8	32	18	10	30	15	32	32	35	SPPB-M08-XS	ASB-M08-XS	SB-M08-XS	
1NA-M12-NMO	1NA-M12-NNO	12	39	20	12	38	20	43	42	43	SSEPBM12-XS	ASB-M12-XS	SB-M12-XS	
1NA-M16-NMO	1NA-M16-NNO	16	43	24	16	47	25	53	50	53	SSEPBM16-XS	ASB-M16-XS	SB-M16-XS	
1NA-M20-NMO	1NA-M20-NNO	20	54	30	20	55	30	60	60	60	SSEPBM20-XS	ASB-M20-XS	SB-M20-XS	
1NA-M25-NMO	1NA-M25-NNO	25	67	38	25	65	35	78	74	78	SSEPBM25-XS	ASB-M25-XS	SB-M25-XS	
1NA-M30-NMO	1NA-M30-NNO	30	79	40	28	75	40	87	84	87	SSEPBM30-XS	ASB-M30-XS	SB-M30-XS	
1NA-M40-NMO	1NA-M40-NNO	40	91	48	32	95	50	108	108	108	SSEPBM40-XS	ASB-M40-XS	SB-M40-XS	

End Support Linear Guide 1NA with 1 Twin Pillow Block												(Dimensions in mm)		
Part Number		Nom. Dia.	L2	L3	L4	H	H1	B	Bb	B9	Pillow Block	Shaft Support		
W/ Type ASB Shaft Supports	W/ Type SB Shaft Supports											Type ASB	Type SB	
1NA-M08-PMO	1NA-M08-PNO	8	62	18	10	30	15	32	32	35	SPTWN-M08-XS	ASB-M08-XS	SB-M08-XS	
1NA-M12-PMO	1NA-M12-PNO	12	76	20	12	38	20	43	42	43	SSETWN-M12-XS	ASB-M12-XS	SB-M12-XS	
1NA-M16-PMO	1NA-M16-PNO	16	84	24	16	47	25	53	50	53	SSETWN-M16-XS	ASB-M16-XS	SB-M16-XS	
1NA-M20-PMO	1NA-M20-PNO	20	104	30	20	55	30	60	60	60	SSETWN-M20-XS	ASB-M20-XS	SB-M20-XS	
1NA-M25-PMO	1NA-M25-PNO	25	130	38	25	65	35	78	74	78	SSETWN-M25-XS	ASB-M25-XS	SB-M25-XS	
1NA-M30-PMO	1NA-M30-PNO	30	152	40	28	75	40	87	84	87	SSETWN-M30-XS	ASB-M30-XS	SB-M30-XS	
1NA-M40-PMO	1NA-M40-PNO	40	176	48	32	95	50	108	108	108	SSETWN-M40-XS	ASB-M40-XS	SB-M40-XS	

Shaft Deflection Note: Load limit may be below the dynamic load rating due to shaft deflection. Bearings can accommodate up to 1/2° deflection. See Engineering Section (pg B-67) for Deflection calculations.

Dynamic Load Capacity Matrix (100 km travel)					Dynamic Load Capacity Matrix (100 km travel)				
Linear Guide Assembly Part No.		Dynamic Load Capacity (N) (Even Distribution)	Pillow Block Part No.	Pillow Block Dynamic Load Capacity (N)	Linear Guide Assembly Part No.		Dynamic Load Capacity (N) (Even Distribution)	Pillow Block Part No.	Pillow Block Dynamic Load Capacity (N)
1NA-M08-NMO	1NA-M08-NNO	620	SPPB-M08-XS	310	1NA-M08-PMO	1NA-M08-PNO	500	SPTWN-M08-XS	500
1NA-M12-NMO	1NA-M12-NNO	1300	SSEPBM12-XS	650	1NA-M12-PMO	1NA-M12-PNO	1060	SSETWN-M12-XS	1060
1NA-M16-NMO	1NA-M16-NNO	4400	SSEPBM16-XS	2200	1NA-M16-PMO	1NA-M16-PNO	4400	SSETWN-M16-XS	4400
1NA-M20-NMO	1NA-M20-NNO	8000	SSEPBM20-XS	4000	1NA-M20-PMO	1NA-M20-PNO	8000	SSETWN-M20-XS	8000
1NA-M25-NMO	1NA-M25-NNO	13400	SSEPBM25-XS	6700	1NA-M25-PMO	1NA-M25-PNO	13400	SSETWN-M25-XS	13400
1NA-M30-NMO	1NA-M30-NNO	16600	SSEPBM30-XS	8300	1NA-M30-PMO	1NA-M30-PNO	16600	SSETWN-M30-XS	16600
1NA-M40-NMO	1NA-M40-NNO	27400	SSEPBM40-XS	13700	1NA-M40-PMO	1NA-M40-PNO	27400	SSETWN-M40-XS	27400

† Super Plus Ball Bushing\* bearings are used in 8 mm size pillow blocks.

### Replacement Component Dimensions

Type SPPB and SSEPB Pillow Blocks (Dimensions in mm)														Type SPTWN and SSETWN Pillow Blocks						
Part Number	Nom. Dia.	L1	H8	H9	B1	B9	J	J1	J6	J7	N Dia.	N2	Mass kg	Part Number	Nom. Dia.	L2	J3	J8	J9	Mass kg
SPPB-M08-XS	8	32	15	28	17,5	35	25	20	15	19,5	3,3	M4	0,07	SPTWN-M08-XS	8	62	50	19,5	25	0,15
SSEPBM12-XS	12	39	18	35	21,5	43	32	23	18	23,0	4,3	M5	0,13	SSETWN-M12-XS	12	76	56	23,0	28	0,27
SSEPBM16-XS	16	43	22	42	26,5	53	40	26	22	25,0	5,3	M6	0,20	SSETWN-M16-XS	16	84	64	25,0	32	0,41
SSEPBM20-XS	20	54	25	50	30,0	60	45	32	25	30,5	6,6	M8	0,35	SSETWN-M20-XS	20	104	76	30,5	38	0,73
SSEPBM25-XS	25	67	30	60	39,0	78	60	40	30	37,0	8,4	M10	0,66	SSETWN-M25-XS	25	130	94	37,0	47	1,37
SSEPBM30-XS	30	79	35	70	43,5	87	68	45	35	43,0	8,4	M10	0,99	SSETWN-M30-XS	30	152	106	43,0	53	2,04
SSEPBM40-XS	40	91	45	90	54,0	108	86	58	45	49,0	10,5	M12	1,83	SSETWN-M40-XS	40	176	124	49,0	62	3,73

Housing Material: Aluminum Alloy Grey Anodized. Top plates are sold separately. Please refer to page B-60 under Accessories for P/N and dimensions.

Housing Material: Aluminum Alloy Grey Anodized

Type ASB LinearRace Shaft End Support Block											Type SB LinearRace Shaft End Support Block										
Part Number	Nom. Dia.	A1	B	B3	H1	H3	L3	N3 Dia.	N4	Mass kg	Part Number	Nom. Dia.	A2	B4	Bb	H1	H2	H4	L4	N5 Dia.	Mass kg
ASB-M08-XS	8	16,0	32	22	15	28	18	3,5	M4	0,04	SB-M08-XS	8	16	25	32	15	5,2	27	10	4,5	0,03
ASB-M12-XS	12	21,5	43	30	20	36	20	5,3	M6	0,10	SB-M12-XS	12	21	32	42	20	5,5	35	12	5,5	0,06
ASB-M16-XS	16	26,5	53	38	25	43	24	6,6	M8	0,15	SB-M16-XS	16	25	40	50	25	6,5	42	16	5,5	0,11
ASB-M20-XS	20	30,0	60	42	30	51	30	8,4	M10	0,23	SB-M20-XS	20	30	45	60	30	8,0	50	20	5,5	0,21
ASB-M25-XS	25	39,0	78	56	35	61	38	10,5	M12	0,41	SB-M25-XS	25	37	60	74	35	9,0	58	25	6,6	0,35
ASB-M30-XS	30	43,5	87	64	40	71	40	10,5	M12	0,53	SB-M30-XS	30	42	68	84	40	10,0	68	28	9,0	0,52
ASB-M40-XS	40	54,0	108	82	50	88	48	13,5	M16	0,99	SB-M40-XS	40	54	86	108	50	12,0	86	32	11,0	0,92

End Support Material: Aluminum Alloy Grey Anodized

End Support Material: Iron



©2003 Danaher Motion. Printed in the U.S.A. The specifications in this publication are believed to be accurate and reliable. However, it is the responsibility of the product user to determine the suitability of Thomson products for a specific application. While defective products will be replaced without charge if promptly returned, no liability is assumed beyond such replacement.

## Continuous Support 1CA

Fully Supported, Highest Performance  
Industry Standard Dimensions  
Inch

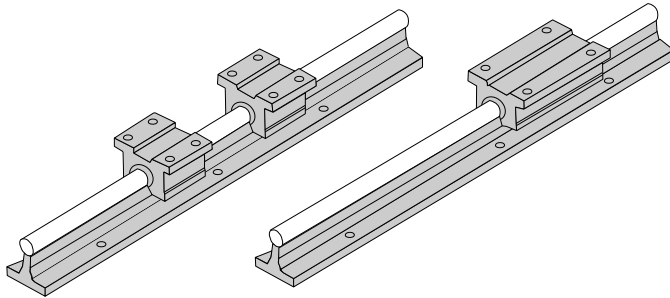

### Features

- Requires only one part number to specify the entire linear guide
- Used as a load support, transport, and guidance solution
- Used in continuously supported applications when rigidity is required

### Components

- 2 Super Smart Ball Bushing\* opentype pillow blocks or 1 Super Smart Ball Bushing open twin pillow blocks
- 1 60 Case\* LinearRace\* shaft support rail assembly

### Specifying this Thomson Linear Guide:

1. Determine the proper Linear Guide for your load and life requirements.
2. Select the part number.
3. Add the letter "L" followed by the overall length in inches, as a suffix to the part number.

### Part Numbering System

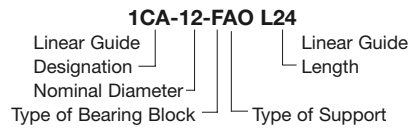

### Dimensions (Inch)

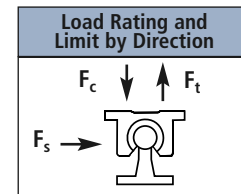
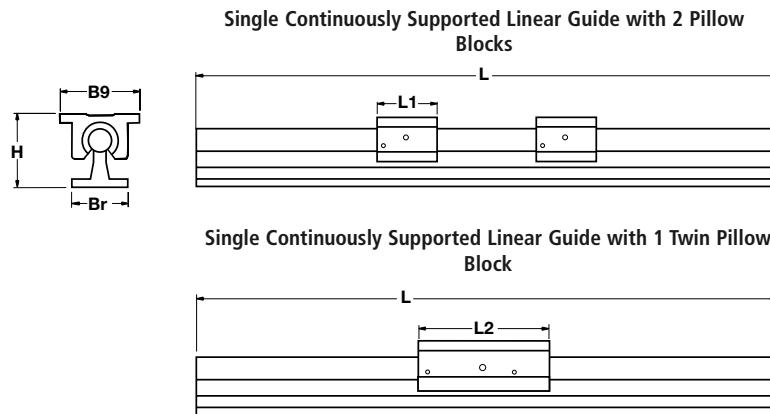

	Dynamic Load Rating	Load Limit
$F_c$	C	C
$F_t$	0.5C	0.5C
$F_s$	C	0.5C

Dynamic Load Rating  
Load value used in life calculation.  
Load Limit  
Maximum allowable load applied to bearing.

Type SSUPBO Open Type Super Smart Ball Bushing Pillow Block  
Type SPB-OPN Open Type Ball Bushing Pillow Block

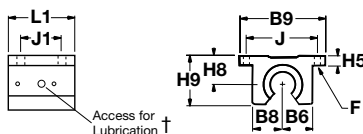

Type SSUTWN Open Type Super Smart Ball Bushing Twin Pillow Block  
Type TWN-OPN Open Type Ball Bushing Twin Pillow Block

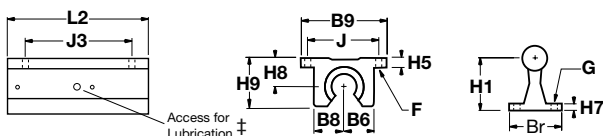

Type SRA LinearRace Shaft Support Rail Assembly

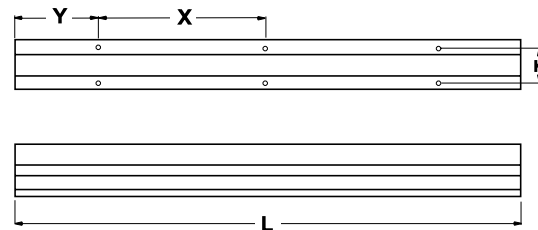

† Size .500 inch has oil lubricant fitting.  
Sizes .625 and above have 1/4-28 access for lubrication.

Continuously Supported Linear Guide 1CA Single with 2 Pillow Blocks						(Dimensions in inches)	
Part Number	Nominal Diameter	L1	H	Br	B9	Pillow Block	Shaft Support Rail Assembly
1CA-08-FAO	.50	1.50	1.812	1.50	2.00	SPB-8-OPN-XS	SRA-8-XS
1CA-12-FAO	.75	1.88	2.437	1.75	2.75	SSUPBO-12-XS	SRA-12-XS
1CA-16-FAO	1.00	2.63	2.937	2.13	3.25	SSUPBO-16-XS	SRA-16-XS
1CA-20-FAO	1.25	3.38	3.625	2.50	4.00	SSUPBO-20-XS	SRA-20-XS
1CA-24-FAO	1.50	3.75	4.250	3.00	4.75	SSUPBO-24-XS	SRA-24-XS

Continuously Supported Linear Guide 1CA Single with 1 Twin Pillow Block							(Dimensions in inches)	
Part Number	Nominal Diameter	L2	H	Br	B9	Maximum Stroke Length	Pillow Block	Shaft Support Rail Assembly
1CA-08-HAO	.50	3.5	1.812	1.50	2.00	L-(3.5)	TWN-8-OPN-XS	SRA-8-XS
1CA-12-HAO	.75	4.5	2.437	1.75	2.75	L-(4.5)	SSUTWNO-12-XS	SRA-12-XS
1CA-16-HAO	1.00	6.0	2.937	2.13	3.25	L-(6.0)	SSUTWNO-16-XS	SRA-16-XS
1CA-20-HAO	1.25	7.5	3.625	2.50	4.00	L-(7.5)	SSUTWNO-20-XS	SRA-20-XS
1CA-24-HAO	1.50	9.0	4.250	3.00	4.75	L-(9.0)	SSUTWNO-24-XS	SRA-24-XS

Dynamic Load Rating (C) Matrix (4 million inches travel)			
Linear Guide Assembly Part No.	Dynamic Load Rating, C (lbf) (Even Distribution)	Pillow Block Part No.	Pillow Block Dynamic Load Rating, C (lbf)
1CA-08-FAO	290	SPB-8-OPN-XS	145
1CA-12-FAO	1800	SSUPBO-12-XS	900
1CA-16-FAO	3000	SSUPBO-16-XS	1500
1CA-20-FAO	3730	SSUPBO-20-XS	1865
1CA-24-FAO	6160	SSUPBO-24-XS	3080

Dynamic Load Rating (C) Matrix (4 million inches travel)			
Linear Guide Assembly Part No.	Dynamic Load Rating, C (lbf) (Even Distribution)	Pillow Block Part No.	Pillow Block Dynamic Load Rating, C (lbf)
1CA-08-HAO	290	TWN-8-OPN-XS	290
1CA-12-HAO	1800	SSUTWNO-12-XS	1800
1CA-16-HAO	3000	SSUTWNO-16-XS	3000
1CA-20-HAO	3730	SSUTWNO-20-XS	3730
1CA-24-HAO	6160	SSUTWNO-24-XS	6160

† Super Ball Bushing\* bearings are used in .500 inch size pillow blocks.

### Replacement Component Dimensions

Type SPB-OPN and SSUPBO Pillow Blocks (Dimensions in Inches)											Type TWN-OPN and SSUTWNO Pillow Blocks								
Part Number	Nom. Dia.	L1	H9	H8	H5	B9	B8	B6	J	J1	F		Wt. lb	Part Number	Nom. Dia.	L2	J3	Wt. lb	
											Bolt	Hole							
SPB-8-OPN-XS	.50		1.50	1.12	.687	.25	2.00		.75		.69	1.69	TWN-8-OPN-XS	.50	3.5	2.5		.40	
SSUPBO-12-XS	.75	1.88	1.56	.937	.31	2.75	1.00	.94	2.38	1.25	#8	.19	.51	SSUTWNO-12-XS	.75	4.5	3.5		1.02
SSUPBO-16-XS	1.00	2.63	2.00	1.187	.38	3.25	1.25	1.19	2.88	1.75	#10	.22	1.03	SSUTWNO-16-XS	1.00	6.0	4.5		2.06
SSUPBO-20-XS	1.25	3.38	2.56	1.500	.43	4.00	1.63	1.50	3.50	2.00	#10	.22	2.15	SSUTWNO-20-XS	1.25	7.5	5.5		4.30
SSUPBO-24-XS	1.50	3.75	2.94	1.750	.50	4.75	1.88	1.75	4.12	2.50	1/4	.28	3.29	SSUTWNO-24-XS	1.50	9.0	6.5		6.88

Top plates are sold separately. Please refer to page B-60 under Accessories for P/N and dimensions.

Housing Material: Aluminum Alloy Black Anodized

Type SRA LinearRace Shaft Support Rail Assembly											(Dimensions in Inches)		
Part Number	Nom. Dia.	H1	H7	Br	K	X	Y	G		Wt. lb/ft			
								Bolt	Hole				
SRA-8-XS	.50	1.125	.19	1.50	1.00	4	2	#6	.17	1.26			
SRA-12-XS	.75	1.500	.25	1.75	1.25	6	3	#10	.22	2.50			
SRA-16-XS	1.00	1.750	.25	2.13	1.50	6	3	1/4	.28	4.06			
SRA-20-XS	1.25	2.125	.31	2.50	1.88	6	3	5/16	.34	6.30			
SRA-24-XS	1.50	2.500	.38	3.00	2.25	8	4	5/16	.34	8.60			

LinearRace Shaft Support Rail Material: Aluminum Alloy Black Anodized

Support rails are supplied in 24 inch lengths unless quoted otherwise. Maximum length of LinearRace Shaft Support Rail is 72 inches. If longer continuous one-piece LinearRace Shaft Support Rails are required, contact the Thomson Linear Guides Application Engineering department.



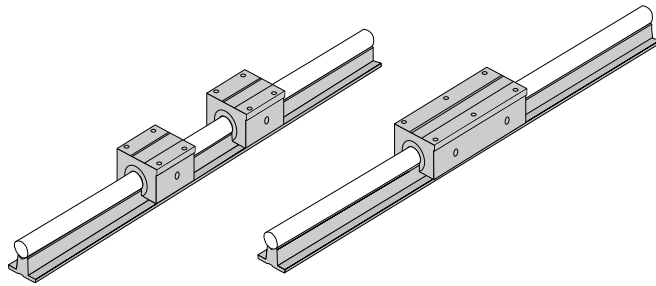

## Continuous Support 1PA

Fully Supported, Highest Performance  
Industry Standard Dimensions

Metric

### Features

- Requires only one part number to specify the entire linear guide
- Used as a load support, transport, and guidance solution
- Used in continuously supported applications when rigidity is required

### Components

- 2 Super Smart Ball Bushing\* opentype pillow blocks or 1 Super Smart Ball Bushing open twin pillow blocks
- 1 60 Case\* LinearRace\* shaft support rail assembly

### Specifying this Thomson Linear Guide:

1. Determine the proper Linear Guide for your load and life requirements.
2. Select the part number.
3. Add the letter "L" followed by the overall length in inches, as a suffix to the part number.

### Part Numbering System

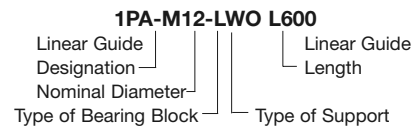

### Dimensions (Metric)

Single Continuously Supported Linear Guide with 2 Pillow Blocks

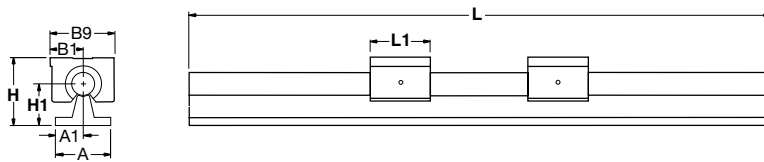

Single Continuously Supported Linear Guide with 1 Twin Pillow Block

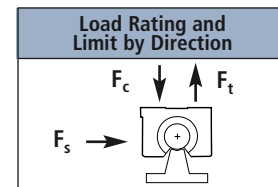
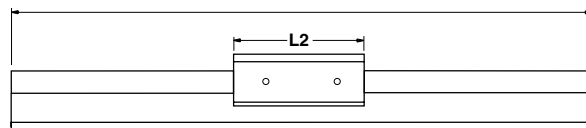

	Dynamic Load Rating	Load Limit
$F_c$	C	C
$F_t$	0.5C	0.5C
$F_s$	C	0.5C

Dynamic Load Rating  
Load value used in life calculation.  
Load Limit  
Maximum allowable load applied to bearing.

Type SSEPBO Open Type Super Smart Ball Bushing Pillow Block

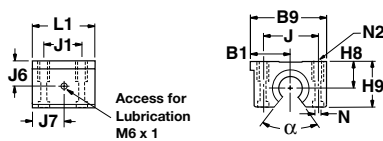

Type SRA LinearRace Shaft Support Rail Assembly

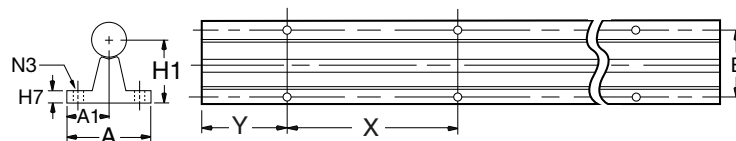

Type SSETWNO Open Type Super Smart Ball Bushing Twin Pillow Block

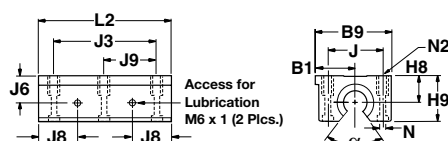



Continuously Supported Linear Guide 1PA Single with 2 Pillow Blocks										(Dimensions in mm)	
Part Number	Nominal Diameter	L1	H	H1	A	A1	B1	B9	Includes		
									Pillow Block	Shaft Support Rail Assembly	
1PA-M12-LWO	12	39	46	28	43	21,5	21,5	43	SPPBO-M12-XS <sup>†</sup>	SRA-M12-XS	
1PA-M16-LWO	16	43	52	30	48	24,0	26,5	53	SSEPBO-M16-XS	SRA-M16-XS	
1PA-M20-LWO	20	54	63	38	56	28,0	30,0	60	SSEPBO-M20-XS	SRA-M20-XS	
1PA-M25-LWO	25	67	72	42	60	30,0	39,0	78	SSEPBO-M25-XS	SRA-M25-XS	
1PA-M30-LWO	30	79	88	53	74	37,0	43,5	87	SSEPBO-M30-XS	SRA-M30-XS	
1PA-M40-LWO	40	91	105	60	78	39,0	54,0	108	SSEPBO-M40-XS	SRA-M40-XS	

Continuously Supported Linear Guide 1PA Single with 1 Twin Pillow Block											(Dimensions in mm)	
Part Number	Nominal Diameter	L2	H	H1	A	A1	B1	B9	Maximum Stroke Length	Includes		
										Pillow Block	Shaft Support Rail Assembly	
1PA-M12-MWO	12	76	46	28	43	21,5	21,5	43	L-(76)	SPTWNO-M12-XS <sup>†</sup>	SRA-M12-XS	
1PA-M16-MWO	16	84	52	30	48	24,0	26,5	53	L-(84)	SSETWNO-M16-XS	SRA-M16-XS	
1PA-M20-MWO	20	104	63	38	56	28,0	30,0	60	L-(104)	SSETWNO-M20-XS	SRA-M20-XS	
1PA-M25-MWO	25	130	72	42	60	30,0	39,0	78	L-(130)	SSETWNO-M25-XS	SRA-M25-XS	
1PA-M30-MWO	30	152	88	53	74	37,0	43,5	87	L-(152)	SSETWNO-M30-XS	SRA-M30-XS	
1PA-M40-MWO	40	176	105	60	78	39,0	54,0	108	L-(176)	SSETWNO-M40-XS	SRA-M40-XS	

Dynamic Load Rating (C) Matrix (100 km travel)			
Linear Guide Assembly Part No.	Dynamic Load Rating, C (N) (Even Distribution)	Pillow Block Part No.	Pillow Block Dynamic Load Rating, C (N)
1PA-M12-LWO	1500	SPPBO-M12-XS	750
1PA-M16-LWO	4400	SSEPBO-M16-XS	2200
1PA-M20-LWO	8000	SSEPBO-M20-XS	4000
1PA-M25-LWO	13400	SSEPBO-M25-XS	6700
1PA-M30-LWO	16600	SSEPBO-M30-XS	8300
1PA-M40-LWO	27400	SSEPBO-M40-XS	13700

Dynamic Load Rating (C) Matrix (100 km travel)			
Linear Guide Assembly Part No.	Dynamic Load Rating, C (N) (Even Distribution)	Pillow Block Part No.	Pillow Block Dynamic Load Rating, C (N)
1PA-M12-MWO	1220	SPTWNO-M12-XS	1500
1PA-M16-MWO	4400	SSETWNO-M16-XS	4400
1PA-M20-MWO	8000	SSETWNO-M20-XS	8000
1PA-M25-MWO	13400	SSETWNO-M25-XS	13400
1PA-M30-MWO	16600	SSETWNO-M30-XS	16600
1PA-M40-MWO	27400	SSETWNO-M40-XS	27400

<sup>†</sup> Super Plus Ball Bushing\* bearings are used in 12 mm size pillow blocks.

### Replacement Component Dimensions

Type SSEPBO Pillow Blocks (Dimensions in mm)														Type SSETWNO Pillow Blocks							
Part Number	Nom. Dia.	L1	H8	H9	B1	B9	J6	J7	J	J1	N Dia.	N2	a Deg	Mass kg	Part Number	Nom. Dia.	L2	J3	J8	J9	Mass kg
SPPBO-M12-XS	12	39	18	28	21,5	43	16,7	19,5	32	23	4,3	M5	66	0,11	SPTWNO-M12-XS	12	76	56	19,5	28	0,22
SSEPBO-M16-XS	16	43	22	35	26,5	53	22,0	21,5	40	26	5,3	M6	66	0,17	SSETWNO-M16-XS	16	84	64	21,5	32	0,34
SSEPBO-M20-XS	20	54	25	41	30,0	60	25,0	27,0	45	32	6,6	M8	60	0,30	SSETWNO-M20-XS	20	104	76	27,0	38	0,63
SSEPBO-M25-XS	25	67	30	50	39,0	78	31,5	33,5	60	40	8,4	M10	60	0,57	SSETWNO-M25-XS	25	130	94	33,6	47	1,18
SSEPBO-M30-XS	30	79	35	60	43,5	87	33,0	39,5	68	45	8,4	M10	60	0,87	SSETWNO-M30-XS	30	152	106	39,5	53	1,70
SSEPBO-M40-XS	40	91	45	77	54,0	108	43,5	45,5	86	58	10,5	M12	60	1,62	SSETWNO-M40-XS	40	176	124	45,5	62	3,18

Housing Material: Aluminum Alloy Grey Anodized  
 Top plates are sold separately. Please refer to page B-60 under Accessories for P/N and dimensions.

Housing Material: Aluminum Alloy Grey Anodized

Type SRA LinearRace Shaft Support Rail Assembly (Dimensions in mm)										
Part Number	Nom. Dia.	H1	H7	A	A1	E	X	Y	N3 Dia.	Mass kg/m
SRA-M12-XS	12	28	5	43	21,5	29	75	37,5	4,5	4,1
SRA-M16-XS	16	30	5	48	24,0	33	100	50	5,5	6,2
SRA-M20-XS	20	38	6	56	28,0	37	100	50	6,6	9,5
SRA-M25-XS	25	42	6	60	30,0	42	120	60	6,6	13,7
SRA-M30-XS	30	53	8	74	37,0	51	150	75	8,6	20,0
SRA-M40-XS	40	60	8	78	39,0	55	200	100	8,6	32,5

LinearRace Shaft Support Rail Material:  
 Aluminum Alloy Grey Anodized

Support rails are supplied in 600mm lengths unless quoted otherwise.  
 Maximum length of LinearRace Shaft Support Rail is 600mm. If longer continuous one-piece LinearRace Shaft Support Rails are required, contact the Thomson Linear Guides Application Engineering department.



©2003 Danaher Motion. Printed in the U.S.A. The specifications in this publication are believed to be accurate and reliable. However, it is the responsibility of the product user to determine the suitability of Thomson products for a specific application. While defective products will be replaced without charge if promptly returned, no liability is assumed beyond such replacement.

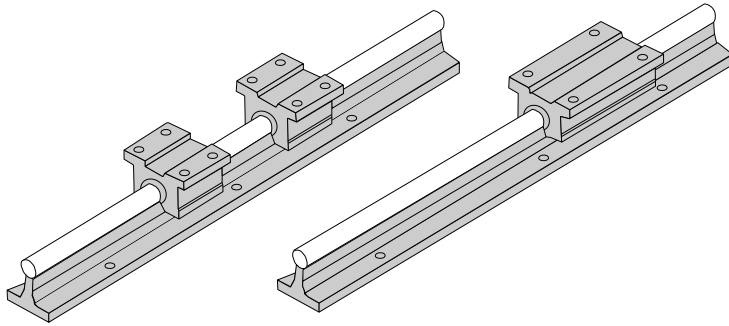

## FluoroNyliner 1VA

### Corrosive/Contaminated Environments

Inch

#### Features

- Requires only one part number to specify the entire linear guide
- Used as a load support, transport, and guidance solution
- Used in continuously supported applications when rigidity is required

#### Components

- 2 self-aligning FluoroNyliner\* Bushing bearing open pillow blocks or 1 self-aligning FluoroNyliner Bushing bearing open twin pillow block
- 1 stainless steel 60 Case\* LinearRace\* shaft support rail assembly

#### Specifying this Thomson Linear Guide:

1. Determine the proper Linear Guide for your load and life requirements.
2. Select the part number.
3. Add the letter "L" followed by the overall length in inches, as a suffix to the part number.

#### Part Numbering System

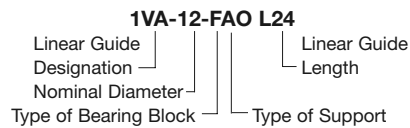

#### Dimensions (Inch)

Single Continuously Supported Linear Guide with 2 Pillow Blocks

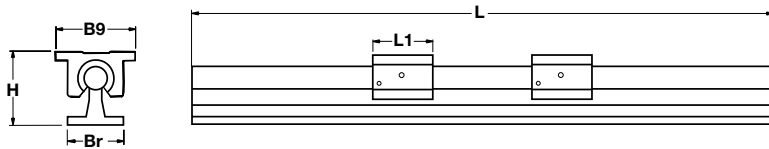

Single Continuously Supported System with 1 Twin Pillow Block

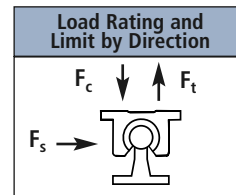
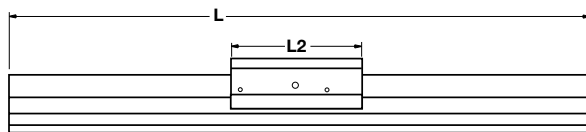

	Dynamic Load Rating	Load Limit
$F_c$	PV	PV
$F_t$	0.3PV	0.3PV
$F_s$	0.6PV	0.6PV

Dynamic Load Rating  
PV value used in life calculation.  
Load Limit  
Maximum allowable PV applied to bearing.

#### FluoroNyliner Linear Guide Pillow Block Dimensions

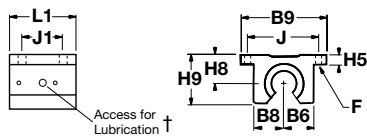

#### FluoroNyliner Linear Guide Twin Pillow Block Dimensions

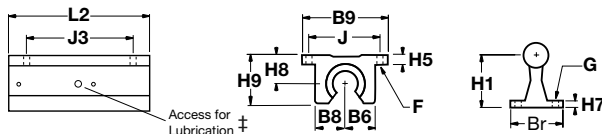

#### Type SRA LinearRace Shaft Support Rail Assembly

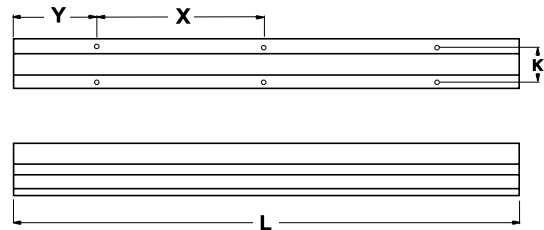

FluoroNyliner* Linear Guide 1VA Single Continuously Supported with 2 Pillow Blocks							(Dimensions in inches)	
Part Number	Nominal Diameter	L1	H	Br	B9	Pillow Block	Shaft Support Rail Assembly	
1VA-08-FAO	.50	1.50	1.812	1.50	2.00	FNYBUPBO08A-XS	SRA-8-XS-SS	
1VA-12-FAO	.75	1.88	2.437	1.75	2.75	FNYBUPBO12A-XS	SRA-12-XS-SS	
1VA-16-FAO	1.00	2.63	2.937	2.13	3.25	FNYBUPBO16A-XS	SRA-16-XS-SS	
1VA-20-FAO	1.25	3.38	3.625	2.50	4.00	FNYBUPBO20A-XS	SRA-20-XS-SS	
1VA-24-FAO	1.50	3.75	4.250	3.00	4.75	FNYBUPBO24A-XS	SRA-24-XS-SS	

FluoroNyliner Linear Guide 1VA Single Continuously Supported with 1 Twin Pillow Block							(Dimensions in inches)	
Part Number	Nominal Diameter	L2	H	Br	B9	Maximum Stroke Length	Pillow Block	Shaft Support Rail Assembly
1VA-08-HAO	.50	3.5	1.812	1.50	2.00	L-(3.5)	FNYBUTWNO08A-XS	SRA-8-XS-SS
1VA-12-HAO	.75	4.5	2.437	1.75	2.75	L-(4.5)	FNYBUTWNO10A-XS	SRA-12-XS-SS
1VA-16-HAO	1.00	6.0	2.937	2.13	3.25	L-(6.0)	FNYBUTWNO16A-XS	SRA-16-XS-SS
1VA-20-HAO	1.25	7.5	3.625	2.50	4.00	L-(7.5)	FNYBUTWNO20A-XS	SRA-20-XS-SS
1VA-24-HAO	1.50	9.0	4.250	3.00	4.75	L-(9.0)	FNYBUTWNO24A-XS	SRA-24-XS-SS

### Maximum Operating Parameters per Bearing

Characteristic	Limit
Liner Temperature Range	-240° C to 288° C (-400° F to 550° F)
Velocity, dry	42.7 m/min. Continuous
Velocity, dry	122 m/min. Intermittent
Velocity, lubricated	122 m/min. Continuous
Pressure	10.35 MPa
PV	21 MPa/m/min

### Replacement Component Dimensions

Self-Aligning Pillow Blocks												(Dimensions in inches)	
Part Number	Nom. Dia.	L1	H9	H8	H5	B9	B8	B7	J	J1	F		Wt. lb
											Bolt	Hole	
FNYBUPBO08A-XS	.50	1.50	1.12	.687	.25	2.00	.75	.69	1.69	1.00	#6	.16	.20
FNYBUPBO12A-XS	.75	1.88	1.56	.937	.31	2.75	1.00	.94	2.38	1.25	#8	.19	.51
FNYBUPBO16A-XS	1.00	2.63	2.00	1.187	.38	3.25	1.25	1.19	2.88	1.75	#10	.22	1.03
FNYBUPBO20A-XS	1.25	3.38	2.56	1.500	.43	4.00	1.63	1.50	3.50	2.00	#10	.22	2.15
FNYBUPBO24A-XS	1.50	3.75	2.94	1.750	.50	4.75	1.88	1.75	4.12	2.50	1/4	.28	3.29

Housing Material: Aluminum Alloy Black Anodized

Self-Aligning Twin Pillow Blocks				
Part Number	Nom. Dia.	L2	J3	Wt. lb.
FNYBUTWNO08A-XS	.500	3.50	2.50	.40
FNYBUTWNO12A-XS	.750	4.50	3.50	1.02
FNYBUTWNO16A-XS	1.00	6.00	4.50	2.06
FNYBUTWNO20A-XS	1.25	7.50	5.50	4.30
FNYBUTWNO24A-XS	1.50	9.00	6.50	6.88

Housing Material: Aluminum Alloy Black Anodized

**Performance Note:** For detailed explanations of FluoroNyliner Linear Guide Dynamic and Static Load Capacities, Frictional Characteristics, Wear Rates, Speeds, and Life Expectancy please contact the Danaher Motion Linear Guides Applications Engineering department.

**Product Note:** FluoroNyliner linear guides are shipped free of all lubricants. It is the responsibility of the product user to determine lubricant compatibility with the FluoroNyliner bearing material.

**Product Options:** FluoroNyliner linear guides are available with various inner race materials and platings to accommodate different environments.

Top plates are sold separately. Please refer to p. B-60 under accessories for P/N and dimensions.

Type SRA LinearRace Shaft Support Rail Assembly										(Dimensions in Inches)	
Part Number	Nom. Dia.	H1	H7	Br	K	X	Y	G		Wt. lb/ft	
								Bolt	Hole		
SRA-8-XS-SS	.50	1.125	.19	1.50	1.00	4	2	#6	.17	1.26	
SRA-12-XS-SS	.75	1.500	.25	1.75	1.25	6	3	#10	.22	2.50	
SRA-16-XS-SS	1.00	1.750	.25	2.13	1.50	6	3	1/4	.28	4.06	
SRA-20-XS-SS	1.25	2.125	.31	2.50	1.88	6	3	5/16	.34	6.30	
SRA-24-XS-SS	1.50	2.500	.38	3.00	2.25	8	4	5/16	.34	8.60	

LinearRace Support Rail Material: Aluminum Alloy Black Anodized

Support rails are supplied in 24 inch lengths unless quoted otherwise.  
 Maximum length of LinearRace Shaft Support Rail is 72 inches. If longer continuous one-piece LinearRace Shaft Support Rails are required, contact the Danaher Motion Linear Guide Application Engineering department.



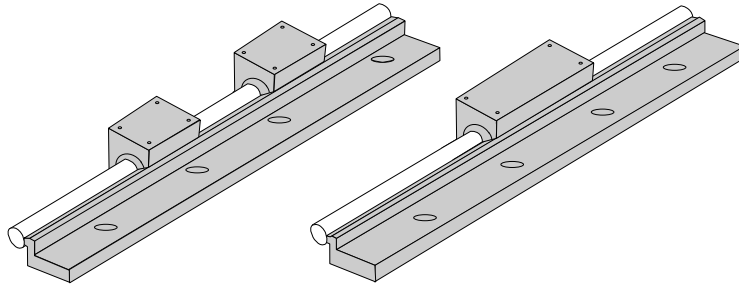

## Side Mounted 1DA

Side Mounted for Low Profile  
Inch

### Features

- Continuously supported design increases rigidity and provides for unlimited linear guide travel lengths
- Versatile Side Support Rail Assembly geometry for optimizing mounting ability
- Side mounted design provides an increase in pull-off load capacity

### Components

- 2 Super Smart Ball Bushing\* modified open type pillow blocks or 1 Super Smart Ball Bushing modified open type twin pillow block.
- 1 60 Case\* LinearRace\* shaft side mounted support rail assembly

### Specifying this Thomson Linear Guide:

- Determine the proper Linear Guide for your load and life requirements.
- Select the part number.
- Add the letter "L" followed by the overall length in inches, as a suffix to the part number.

### Part Numbering System

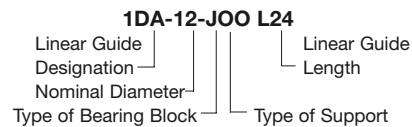

### Dimensions (Inch)

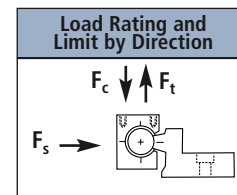
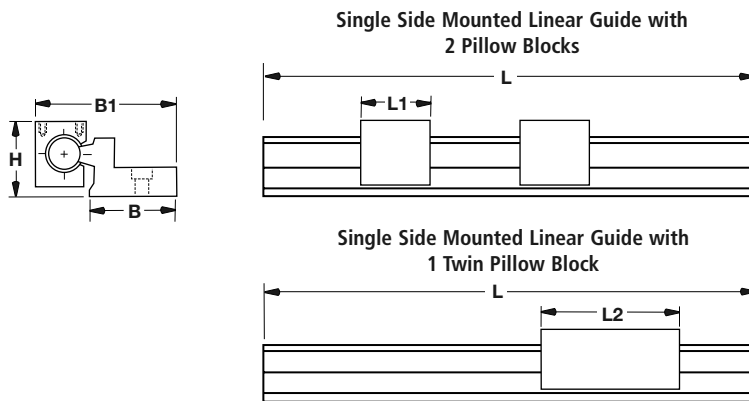

	Dynamic Load Rating	Load Limit
$F_c$	C	0.5C
$F_t$	0.5C	0.5C
$F_s$	C	C

Dynamic Load Rating  
Load value used in life calculation.  
Load Limit  
Maximum allowable load applied to bearing.

Type SSUPBO-MOD Open Type Pillow Block  
Type SPB-OPN-MOD Open Type Pillow Block

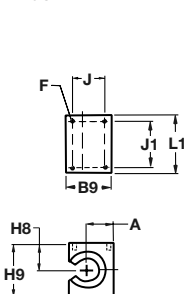

Type SSUTWNO-MOD Pillow Block  
Type TWN-OPN-MOD Pillow Block

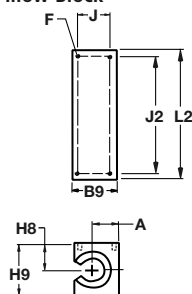

Type SSRA Side Mounted LinearRace Shaft Support Rail Assembly

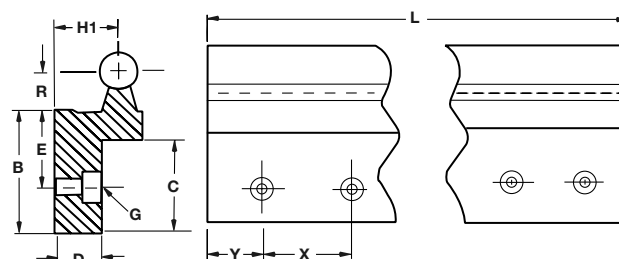

Side Mounted Linear Guide 1DA Single Side Mounted with 2 Pillow Blocks							(Dimensions in inches)	
Part Number	Nominal Diameter	H	B	B1	L1	Pillow Block	Shaft Support Rail Assembly	
1DA-08-JOO	.50	1.562	1.44	2.61	1.50	SPB-8-OPN-MOD	SSRA-8	
1DA-12-JOO	.75	2.062	1.94	3.55	1.88	SSUPBO-12-MOD	SSRA-12	
1DA-16-JOO	1.00	2.562	2.44	4.49	2.63	SSUPBO-16-MOD	SSRA-16	

Side Mounted Linear Guide 1DA Single Side Mounted with 1 Twin Pillow Block							(Dimensions in inches)	
Part Number	Nominal Diameter	H	B	B1	L2	Maximum Stroke Length	Pillow Block	Shaft Support Rail Assembly
1DA-08-KOO	.50	1.562	1.44	2.61	3.5	L-(3.5)	TWN-8-OPN-MOD	SSRA-8
1DA-12-KOO	.75	2.062	1.94	3.55	4.5	L-(4.5)	SSUTWNO-12-MOD	SSRA-12
1DA-16-KOO	1.00	2.562	2.44	4.49	6.0	L-(6.0)	SSUTWNO-16-MOD	SSRA-16

### Mounting Configurations

The following mounting configurations depict ideas for combining the Side Mounted Continuously Supported Linear Guides into your linear motion application. If you need further information, contact the Danaher Motion Application Engineering Department.

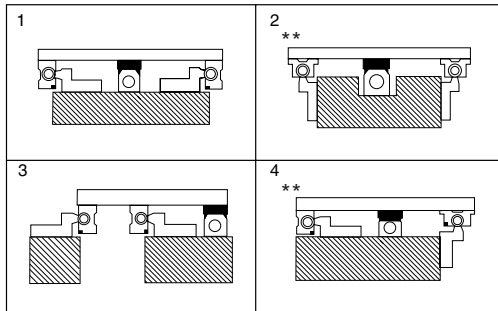

\*\*Pillow blocks shown are the standard SSUPBO or SPB-OPN style. To order System 1DA with standard pillow blocks, order the Side Mounted Shaft Rail Assembly (SSRA) and the SSUPBO or SPB-OPN separately.

### Dynamic Load Rating (C) Matrix (4 million inches travel)

Linear Guide Assembly Part No.	Dynamic Load Rating, C (lbf) (Even Distribution)	Pillow Block Part No.	Pillow Block Dynamic Load Rating, C (lbf)
1DA-08-JOO	240	SPB-8-OPN-MOD	120
1DA-12-JOO	1600	SSUPBO-12-MOD	800
1DA-16-JOO	2700	SSUPBO-16-MOD	1350
1DA-08-KOO	240	TWN-8-OPN-MOD	240
1DA-12-KOO	1600	SSUTWNO-12-MOD	1600
1DA-16-KOO	2700	SSUTWNO-16-MOD	2700

† Super Ball Bushing\* bearings are used in .500 inch size pillow blocks.

### Replacement Component Dimensions

Type SPB-OPN-MOD and SSUPBO-MOD Pillow Block (Dimensions in inches)										Type TWN-OPN-MOD and SSUTWNO-MOD Pillow Blocks					
Part Number	Nom. Dia.	H8	H9	A	B9	L1	J	J1	F	Wt. lb	Part Number	Nom. Dia.	L2	J2	Wt. lb
SPB-08-OPN-MOD	.50	.687	1.44	.67	1.12	1.50	.812	1.250	#8-32	.18	TWN-8-OPN-MOD	.50	3.5	3.00	.39
SSUPBO-12-MOD	.75	.937	1.94	.92	1.56	1.88	1.187	1.562	#10-32	.45	SSUTWNO-12-MOD	.75	4.5	4.00	1.00
SSUPBO-16-MOD	1.00	1.187	2.44	1.17	2.00	2.63	1.438	2.250	1/4-20	.98	SSUTWNO-16-MOD	1.00	6.0	5.25	2.11

Housing Material: Aluminum Alloy Black Anodized

Top plates are sold separately. Please refer to p. B-51 under accessories for P/N and dimensions.

Housing Material: Aluminum Alloy Black Anodized

### Type SSRA Side Mounted LinearRace Shaft Support Rail Assembly (Dimensions in Inches)

Part Number	Nom. Dia.	H1	B	R	E	D	C	X	Y <sup>(1)</sup>	G		Wt. lb/ft
										Bolt	Hole	
SSRA-08	.500	.875	1.44	.500	1.00	.49	1.06	4	2	1/4	.28	2.05
SSRA-12	.750	1.125	1.94	.688	1.31	.75	1.44	6	3	5/16	.34	4.00
SSRA-16	1.000	1.375	2.44	.875	1.63	.88	1.81	6	3	3/8	.41	6.25

(1) For standard lengths

LinearRace Shaft Support Rail Material: Aluminum Black Anodized

Support rails are supplied in 24 inch lengths unless quoted otherwise. Maximum length of LinearRace Shaft Support Rail is 72 inches. If longer continuous one-piece LinearRace Shaft Support Rails are required, contact the Danaher Motion Linear Guides Application Engineering department.

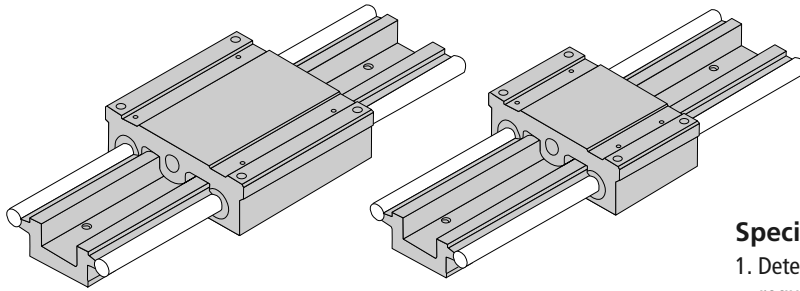

## Dual Shaft Rail\* 2DA with Integrated Carriage Unpack and Install Inch

### Features

- Used in continuously supported applications when rigidity is required
- Adaptable to any drive system
- Pre-aligned and preassembled for immediate installation and use
- Designed for medium to heavy loads

### Components

- 1 Dual LinearRace\* shaft rail assembly
- 1 integrated carriage with 4 open type Super Smart Ball Bushing\* bearings

### Specifying this Thomson Linear Guide:

1. Determine the proper Linear Guide for your load and life requirements.
2. Select the part number.
3. Add the letter "L" followed by the overall length in inches, as a suffix to the part number.

### Part Numbering System

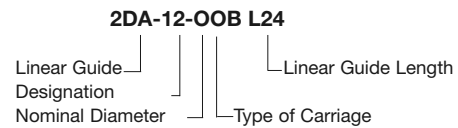

### Dimensions (Inch)

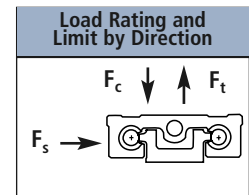
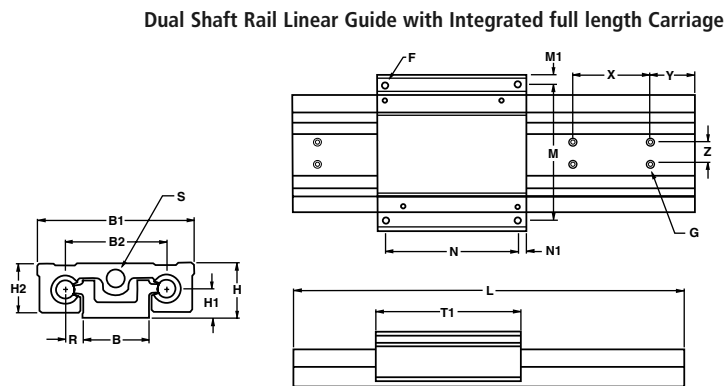
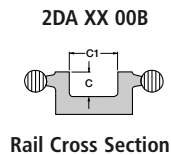

	Dynamic Load Rating	Load Limit
$F_c$	C	0.5C
$F_t$	C	0.5C
$F_s$	0.5C	0.5C

**Dynamic Load Rating**  
Load value used in life calculation.  
**Load Limit**  
Maximum allowable load applied to bearing.

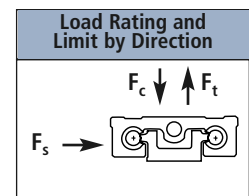
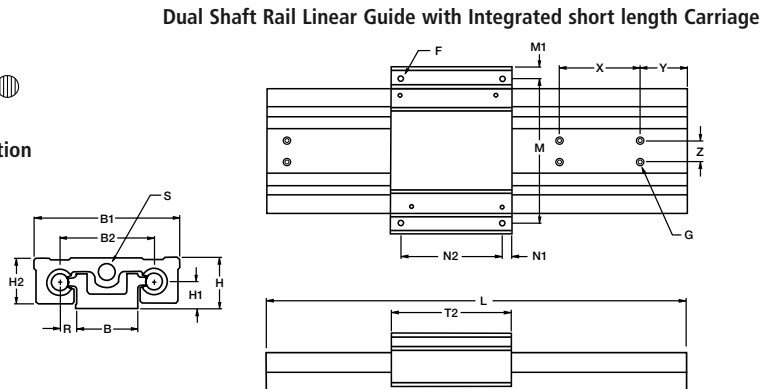
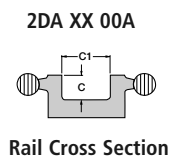

	Dynamic Load Rating	Load Limit
$F_c$	C	0.5C
$F_t$	C	0.5C
$F_s$	0.5C	0.5C

**Dynamic Load Rating**  
Load value used in life calculation.  
**Load Limit**  
Maximum allowable load applied to bearing.

Dual Shaft Rail Linear Guide 2DA with Integrated Carriage											(Dimensions in inches)	
Part Number	Nominal Diameter	T1	H	H1	H2	B	R	B1	B2	C	C1	
2DA-08-OOB	.50	4.5	1.625	.875	1.43	2.00	.500	4.6	3.0	.64	1.25	
2DA-12-OOB	.75	6.0	2.125	1.125	1.93	2.63	.688	6.1	4.0	.75	1.62	
2DA-16-OOB	1.00	7.5	2.625	1.375	2.44	3.25	.875	7.6	5.0	.99	2.00	

Dual Shaft Rail Linear Guide 2DA with Integrated Carriage													(Dimensions in inches)	
Part Number	N	N1	M	M1	X	Y	Z	S As Extruded	F	G		Max. Stroke Length	Includes	
										Bolt	Hole		Carriage Part Number	Dual Shaft Rail Asmby. Part No.
2DA-08-OOB	4.00	.25	4.00	.30	4.0	2.0	.75	.50	#10-32	1/4	.28	L-(4.5)	DSRC-08-SB	DSRA-08
2DA-12-OOB	5.25	.37	5.25	.42	6.0	3.0	1.00	.70	1/4-20	5/16	.34	L-(6.0)	DSRC-12-SB	DSRA-12
2DA-16-OOB	6.75	.37	6.75	.42	6.0	3.0	1.25	.90	5/16-18	3/8	.41	L-(7.5)	DSRC-16-SB	DSRA-16

Support rails are supplied in 24 inch lengths unless quoted otherwise.  
 Dual Shaft Rail Support Material: Black Anodized Aluminum Alloy  
 Maximum continuous length of support rails is 72". If longer continuous shaft support rails are required, please contact the Danaher Motion Linear Guides Application Engineering department.

Dynamic Load Rating (C) Matrix (4 million inches travel)		
Linear Guide Assembly Part No.	Dynamic Load Rating, C (lbf) (Even Distribution)	Dynamic Roll Moment Rating, C (in - lbf)
2DA-08-OOB	480	720
2DA-12-OOB	3200	6400
2DA-16-OOB	5400	13500

Note: Above load ratings used for life calculations. Load limit of assembly 50%.

Dual Shaft Rail Linear Guide 2DA with Integrated Carriage											(Dimensions in inches)	
Part Number	Nominal Diameter	T2	H	H1	H2	B	R	B1	B2	C	C1	
2DA-08-OOA	.500	3.5	1.625	.875	1.43	2.00	.500	4.60	3.0	.64	1.25	
2DA-12-OOA	.750	4.5	2.125	1.125	1.93	2.63	.688	6.10	4.0	.75	1.62	
2DA-16-OOA	1.000	6.0	2.625	1.375	2.44	3.25	.875	7.60	5.0	.99	2.00	

Dual Shaft Rail Linear Guide 2DA with Integrated Carriage													(Dimensions in inches)	
Part Number	N	N2	M	M1	X	Y	Z	S As Extruded	F	G		Max. Stroke Length	Includes	
										Bolt	Hole		Carriage Part Number	Dual Shaft Rail Asmby. Part No.
2DA-08-OOA	.25	3.00	4.00	.30	4.0	2.0	.75	.50	#10-32	1/4	.28	L-(3.5)	DSRC-08-SA	DSRA-08
2DA-12-OOA	.37	3.75	5.25	.42	6.0	3.0	1.00	.70	1/4-20	5/16	.34	L-(4.5)	DSRC-12-SA	DSRA-12
2DA-16-OOA	.37	5.25	6.75	.42	6.0	3.0	1.25	.90	5/16-18	3/8	.41	L-(6.0)	DSRC-16-SA	DSRA-16

Support rails are supplied in 24 inch lengths unless quoted otherwise.  
 Dual Shaft Rail Support Material: Black Anodized Aluminum Alloy Maximum continuous length of support rails is 72". If longer continuous shaft support rails are required, please contact the Danaher Motion Linear Guides Application Engineering department.

\* Super Ball Bushing\* bearings are used in 500 inch size carriages

Dynamic Load Rating (C) Matrix (4 million inches travel)		
Linear Guide Assembly Part No.	Dynamic Load Rating, C (lbf) (Even Distribution)	Dynamic Roll Moment Rating, C (in - lbf)
2DA-08-OOA	480	720
2DA-12-OOA	3200	6400
2DA-16-OOA	5400	13500

Note: Above load ratings used for life calculations. Load limit of assembly 50%.

## Twin Shaft Web\* 2CA with Universal Carriage Unpack and Install Inch

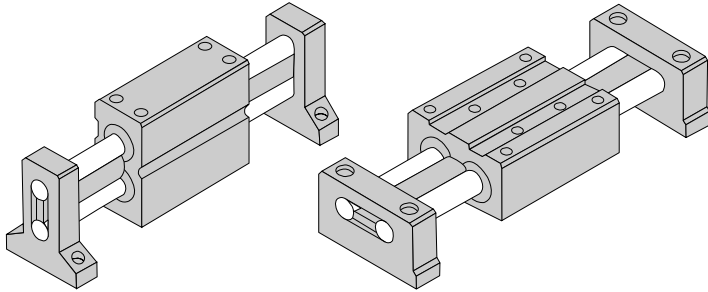

### Features

- Used when spanning or bridging a gap
- Double LinearRace\* shaft and welded integral web design maximizes torque and dramatically improves deflection characteristics
- Pre-aligned for quick and easy installation
- Designed to move medium loads with virtually frictionless travel

### Components

- Universal integrated, carriage with 4 open type Super Smart Ball Bushing\* bearings
- Twin welded 60 Case\* LinearRace shafts with integral web
- 2 vertical or horizontal double end supports

### Specifying this Thomson Linear Guide:

1. Determine the proper Linear Guide for your load and life requirements.
2. Select the part number.
3. Add the letter "L" followed by the overall length in inches, as a suffix to the part number.

### Part Numbering System

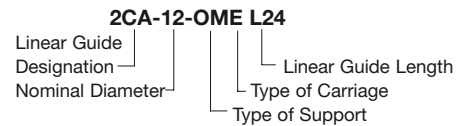

### Dimensions (Inch)

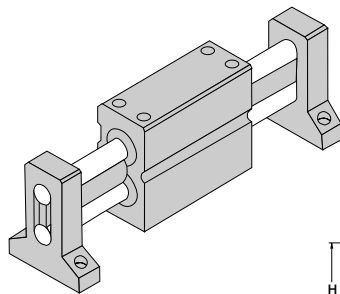

Twin Shaft Web Linear Guide with Universal Carriage  
(Vertical Configuration)

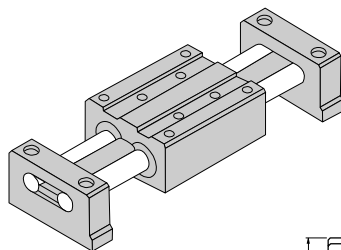
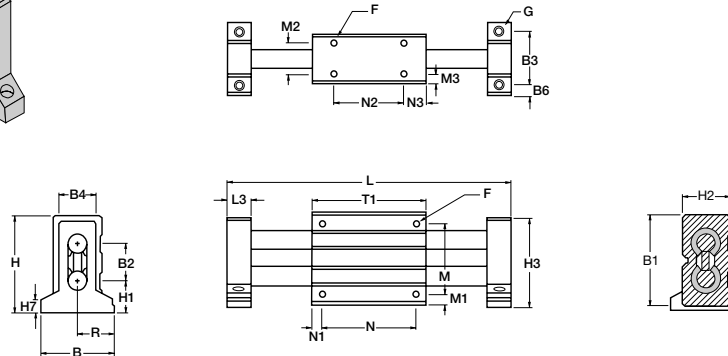

Twin Shaft Web Linear Guide with Universal Carriage  
(Horizontal Configuration)

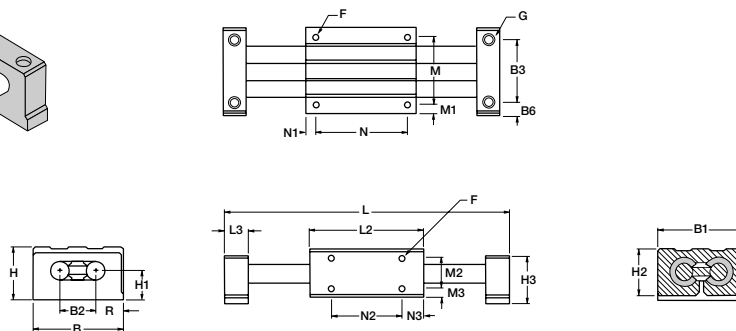



Twin Shaft Web Linear Guide End Supported 2CA (Vertical Configuration)													(Dimensions in inches)		
Part Number	Nominal Diameter	L3	H	H1	H3	H7	B	R	B2	B3	B4	B6	T1	N	
2CA-08-OKE	.50	.63	2.750	.875	2.56	.38	2.25	1.125	1.13	1.63	1.12	.31	3.5	3.00	
2CA-12-OKE	.75	.75	3.625	1.125	3.44	.56	3.00	1.500	1.50	2.25	1.63	.38	4.5	4.00	
2CA-16-OKE	1.00	1.00	4.625	1.375	4.50	.75	4.00	2.000	2.00	3.00	2.25	.50	6.0	5.25	

Twin Shaft Web Linear Guide End Supported 2CA (Vertical Configuration)													(Dimensions in inches)		
Part Number	N1	N2	N3	H2	B1	M	M1	M2	M3	F	G		Max. Stroke Length	Twin Shaft Web Part Number	
											Bolt	Hole			
2CA-08-OKE	.25	2.5	.50	1.5	2.62	2.00	.31	.88	.31	#10-32	#10	.22	L-(4.75)	TSW-08	
2CA-12-OKE	.25	3.5	.50	2.0	3.50	2.87	.31	1.38	.31	1/4-20	1/4	.28	L-(6.00)	TSW-12	
2CA-16-OKE	.38	4.5	.75	2.5	4.50	3.62	.44	1.62	.44	5/16-18	5/16	.34	L-(8.00)	TSW-16	

2CA (Vertical Configuration) Carriage and End Support Part No.		
Linear Guide Part Number	Carriage Part Number	End Support Part Number
2CA-08-OKE	WC-08	WSB-08-V
2CA-12-OKE	WC-12	WSB-12-V
2CA-16-OKE	WC-16	WSB-16-V

Maximum Length is 72 inches.

**Shaft Deflection Note:**  
 Load limit may be below the dynamic load rating due to shaft deflection. Bearings can accommodate up to 1/2° deflection. See Engineering Section (pg B-67) for Deflection calculations.

Dynamic Load Capacity Matrix (4 million inches travel)		
Linear Guide Assembly Part No.	Dynamic Load Capacity (lbf) (Even Distribution)	Dynamic Roll Moment Capacity (in - lbf)
2CA-08-OKE	290	165
2CA-12-OKE	1800	1350
2CA-16-OKE	3000	3000

† Super Ball Bushing\* bearings are used in .500 inch size carriages.

Twin Shaft Web Linear Guide End Supported 2CA (Horizontal Configuration)													(Dimensions in inches)		
Part Number	Nominal Diameter	L3	H	H1	H3	B	R	B2	B3	B6	T1	N			
2CA-08-OME	.50	.63	1.625	.875	1.5	2.62	.750	1.13	2.00	.31	3.5	3.00			
2CA-12-OME	.75	.75	2.125	1.125	2.0	3.50	1.000	1.50	2.75	.37	4.5	4.00			
2CA-16-OME	1.00	1.00	2.625	1.375	2.5	4.50	1.250	2.00	3.62	.50	6.0	5.25			

Twin Shaft Web Linear Guide End Supported 2CA (Horizontal Configuration)													(Dimensions in inches)		
Part Number	N1	N2	N3	H2	B1	M	M1	M2	M3	F	G		Max. Stroke Length	Twin Shaft Web Part Number	
											Bolt	Hole			
2CA-08-OME	.25	2.5	.50	1.5	2.62	2.00	.31	.88	.31	#10-32	#10	.22	L-(4.75)	TSW-08	
2CA-12-OME	.25	3.5	.50	2.0	3.50	2.87	.31	1.38	.31	1/4-20	1/4	.28	L-(6.00)	TSW-12	
2CA-16-OME	.38	4.5	.75	2.5	4.50	3.62	.44	1.62	.44	5/16-18	5/16	.34	L-(8.00)	TSW-16	

2CA (Horizontal Configuration) Carriage and End Support Part No.		
Linear Guide Part Number	Carriage Part Number	End Support Part Number
2CA-08-OME	WC-08	WSB-08-H
2CA-12-OME	WC-12	WSB-12-H
2CA-16-OME	WC-16	WSB-16-H

Maximum Length is 72 inches.

**Shaft Deflection Note:**  
 Load limit may be below the dynamic load rating due to shaft deflection. Bearings can accommodate up to 1/2° deflection. See Engineering Section (pg B-67) for Deflection calculations.

Dynamic Load Capacity Matrix (4 million inches travel)		
Linear Guide Assembly Part No.	Dynamic Load Capacity (lbf) (Even Distribution)	Dynamic Roll Moment Capacity (in - lbf)
2CA-08-OME	290	165
2CA-12-OME	1800	1350
2CA-16-OME	3000	3000

† Super Ball Bushing\* bearings are used in .500 inch size carriages.



## Ball Screw Assemblies

Inch and Metric

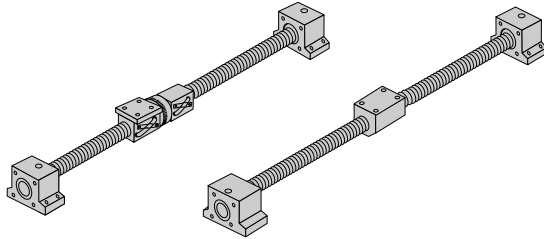

### Features

- Integrated ball screw and supports with motor-ready mounting
- Designed to fit appropriately sized linear guides for custom configurations
- Pre-engineered to meet your system needs

### Components

- 1 Ball Screw Assembly with Ball Nut Mounting Surface (Preloaded or Non-Loaded)
- 2 Integrated End Supports with Angular Contact Bearings
- 1 Motor and Controller with integrated indexer (optional)

### Specifying a Ball Screw Assembly:

1. Determine your drive requirements (torque, speed, acceleration, etc.)
2. Select the part number of the ball screw you have chosen.
3. Place your order with your local authorized distributor.

### Part Numbering System

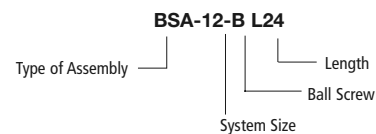

### Dimensions (Inch)

#### Ball Screw Assembly Preloaded

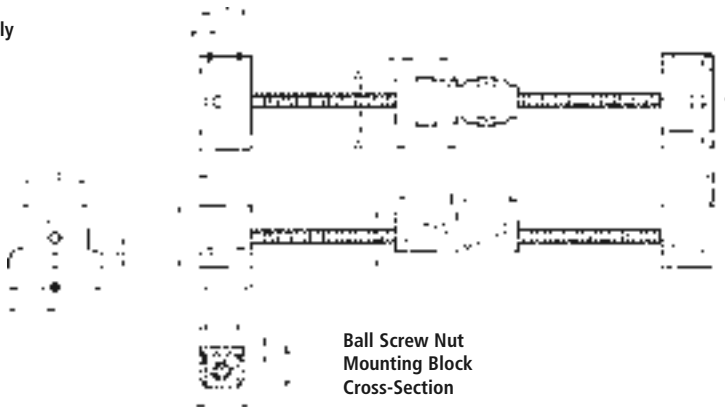

Preloaded Ball Screw Assemblies are predesigned to match the base to pillow block height of 1BA, 1CA and 1VA linear guides. To utilize Ball Screw Assemblies with other linear guides contact the Thomson Systems application engineering department.

#### Ball Screw Assembly Non-Preloaded

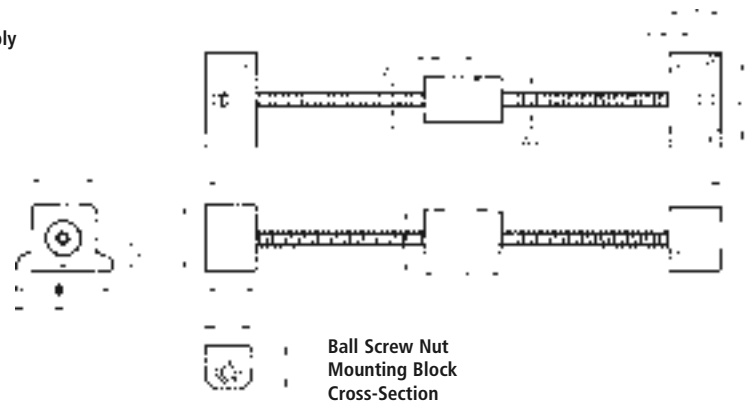

Non-Preloaded Ball Screw Assemblies are predesigned to match the base to pillow block height of 1BA, 1CA and 1VA linear guides. To utilize Ball Screw Assemblies with other linear guides contact the Thomson Systems application engineering department.

# Ball Screw Assemblies

Ball Screw Assemblies - (Preloaded)													(Dimensions in inches)	
Part Number	Ball Screw Dia. x Lead	L3	L5	L6	L8	H	H3	H1	B	B3	B4	R	G	
BSA-08-Q	.500 x .500	1.50	0.75	0.38	2.25	1.812	2.35	1.200	3.80	3.20	2.50	1.900	0.19	
BSA-12-L	.631 x 1.00	2.00	1.00	0.50	-	2.437	2.70	1.500	3.80	3.20	2.50	1.900	0.22	
BSA-16-H	1.00 x .250	2.20	1.20	0.50	2.40	2.937	3.45	1.750	5.00	4.20	3.50	2.500	0.28	
BSA-16-T	1.00 x 1.00													
BSA-24-I	1.50 x .250													
BSA-24-J	1.50 x 1.00	2.80	1.50	0.65	2.82	4.250	5.000	2.500	7.25	6.20	5.00	3.625	0.34	
BSA-24-Z	1.50 x 1.875													

Ball Screw Assemblies - (Preloaded)													(Dimensions in inches)
Part Number	Ball Screw Dia. x Lead	Y	V1	W	W1	F3	L9	A	A1	A5	A7	Motor Frame Size	
BSA-08-Q	.500 x .500	1.00	0.25	0.95	0.14	#6-32	4.50	1.23	1.20	0.23	0.76	NEMA 23	
BSA-12-L	.631 x 1.00	1.93	0.25	1.33	0.18	#8-32	3.44	1.69	1.80	-	-	NEMA 23	
BSA-16-H	1.00 x .250	1.90	0.25	1.63	0.26	#10-32	4.85	2.15	2.03	0.44	2.12	NEMA 34	
BSA-16-T	1.00 x 1.00						5.70					NEMA 34	
BSA-24-I	1.50 x .250						6.38					NEMA 42	
BSA-24-J	1.50 x 1.00	2.00	0.41	2.00	0.37	1/4-20	7.34	2.75	3.25	0.63	2.25	NEMA 42	
BSA-24-Z	1.50 x 1.875						10.63					NEMA 42	

Ball Screw Assemblies (Non-Preloaded)													(Dimension in inches)	
Part Number	Ball Screw Dia. x Lead	L3	L5	L6	L9	H	H3	H1	B	B3	B4	R	G	
BSA-08-F	.500 x .200	1.50	0.75	0.38	2.25	1.812	2.35	1.200	3.80	3.20	2.50	1.90	0.19	
BSA-12-G	.750 x .200	2.00	1.00	0.50	1.80	2.437	2.70	1.500	3.80	3.20	2.50	1.90	0.22	
BSA-M12-B	12mm x 5mm	1.50	0.75	0.38	2.25	1.812	2.35	1.200	3.80	3.20	2.50	1.90	0.19	
BSA-M20-D	20mm x 5mm	2.00	1.00	0.50	2.46	2.437	2.70	1.500	3.80	3.20	2.50	1.90	0.22	

Ball Screw Assemblies (Non-Preloaded)											(Dimension in inches)	
Part Number	Ball Screw Dia. x Lead	A2	A3	A8	V2	V3	W2	W3	W4	F3		
BSA-08-F	.500 x .200	1.19	1.23	0.48	1.00	0.25	0.95	0.12	1.19	#6-32		
BSA-12-G	.750 x .200	1.69	1.80	0.72	1.93	0.25	1.33	0.18	1.69	#8-32		
BSA-M12-B	12mm x 5mm	1.19	1.23	0.48	1.00	0.25	0.95	0.12	1.19	#6-32		
BSA-M20-D	20mm x 5mm	1.69	1.80	0.72	1.93	0.25	1.33	0.18	1.69	#8-32		

Ball Screw Assembly Standard Lengths															(Lengths in inches)		
Part No.	18	24	30	32	36	40	42	48	54	60	64	66	72	80	84	88	96
BSA-08-Q	■	■	■		■		■	■									
BSA-12-L	■	■	■		■		■	■	■								
BSA-16-H	■	■	■		■		■	■	■	■							
BSA-16-T	■	■	■		■		■	■	■	■							
BSA-24-I		■		■		■		■		■	■		■	■		■	■
BSA-24-J		■		■		■		■		■	■		■	■		■	■
BSA-24-Z		■		■		■		■		■	■		■	■		■	■

**Custom Lengths**  
 Custom lengths are also available. For special requirements, please contact the Danaher Motion application engineering department.

For Motion Control Options, see page B-66. To determine system Torque Requirements of Ball Screw travel life refer to the Engineering Support Appendix, page B-67. For Motor Adaptor and Motor Coupling information, see page B-55.

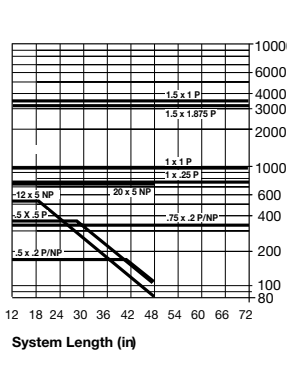
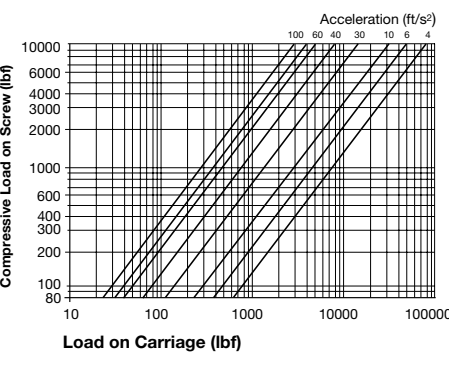
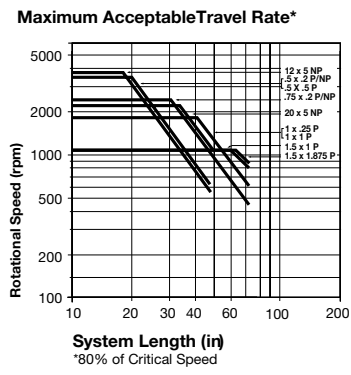

The SuperSlide has a pre-designed **Maximum Acceptable Travel Rate**. Calculate maximum rotational speed (rpm) by dividing your required maximum linear speed (in/min) by the corresponding system ball screw lead (in/rev). Enter the chart with the required system length and your maximum rotational speed. Select the system with a maximum acceptable travel rate curve above the plotted line.

**Compressive load** on the ball screw is a key factor in selecting the proper System. Using maximum load and acceleration requirements, plot compressive load on the left side of the chart. Using System length and compressive load, plot the maximum allowable compressive force on the right chart. Select the System with a rated maximum compressive force above your plotted point.

If you have questions concerning your system requirements, contact the Thomson Systems application engineering department.

**Note:** Ball screw should never exceed recommended critical speed.



\* Trademark of Danaher Motion. DANAHER MOTION is registered in the U.S. Patent and Trademark Office and in other countries.



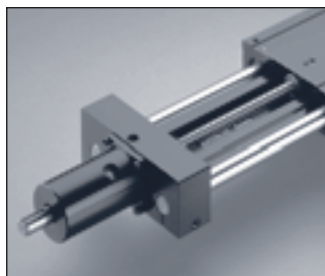

## Accessories

## Collapsible Bellows

Bellows will reduce available stroke length of slide by approximately 28%.

Bellows P/N should be succeeded by a length when ordering

### Bellows Materials:

- Polyester Cover
- PVC Stiffeners

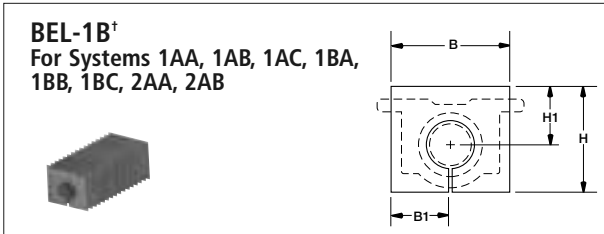

### BEL-1B Moveable Protective Bellows

Part Number	Nom. Shaft Dia.	Dimension (in.)			CR
		H	H1	B	
BEL-1B-04	1/4	1.187	.906	1.812	.163
BEL-1B-06	3/8	1.312	.968	1.937	.108
BEL-1B-08	1/2	1.687	1.156	2.062	.163
BEL-1B-12	3/4	2.000	1.156	2.312	.108
BEL-1B-16	1	2.375	1.281	2.625	.163
BEL-1B-24	1 1/2	3.062	1.531	3.125	.108

<sup>†</sup>Each moveable bellows comes with 1 section of bellows and 2 pairs of Velcro® Fasteners.

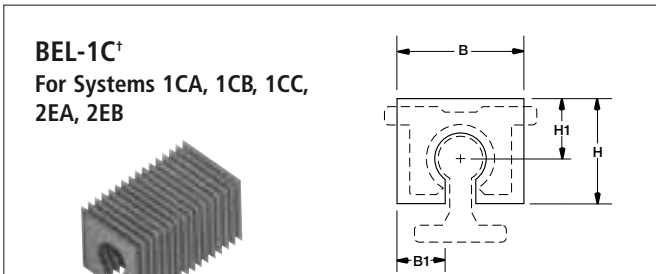

### BEL-1C Moveable Protective Bellows

Part Number	Nom. Shaft Dia.	Dimension (in.)			CR
		H	H1	B	
BEL-1C-08	1/2	1.375	.968	2.062	.088
BEL-1C-12	3/4	1.812	1.062	2.312	.120
BEL-1C-16	1	2.375	1.218	2.625	.088
BEL-1C-24	1 1/2	3.125	1.531	3.125	.088

<sup>†</sup> Each moveable bellows comes with 1 section of bellows and 2 pairs of Velcro® Fasteners.

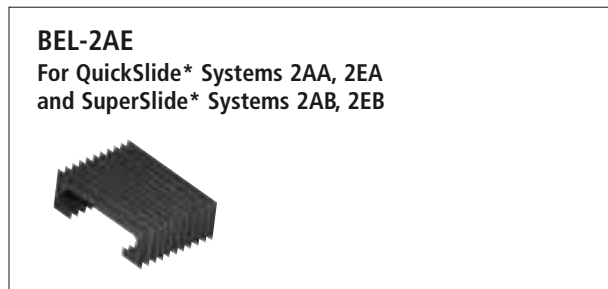

### BEL-2AE Moveable Protective Bellows

Part Number	Nom. Shaft Dia.	Dimension (in.)		
		H	H1	B
BEL-2AE-08	1/2	1.4	1.24	5.25
BEL-2AE-12	3/4	2.1	1.35	6.85
BEL-2AE-16	1	2.8	1.68	8.10
BEL-2AE-24	1 1/2	4.2	2.44	11.18

Each moveable bellows comes with 1 section of bellows and 2 pairs of Velcro® fasteners.

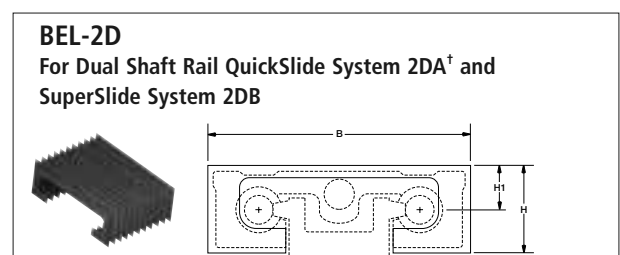

### BEL-2D Dual Shaft Rail Bellows

Part Number	Nom. Shaft Dia.	Dimension (in.)		
		H	H1	B
BEL-2DA-08	1/2	1.50	0.85	4.60
BEL-2DB-08	1/2	1.89	1.34	5.13
BEL-2D-12	3/4	2.406	1.437	6.000
BEL-2D-16	1	2.875	1.687	7.500

Each moveable bellows comes with 1 section of bellows and 2 mounting brackets and mounting screws.

<sup>†</sup>Appropriate arrangements for afixing the Bellows at each end of the QuickSlide 2DA System are required.

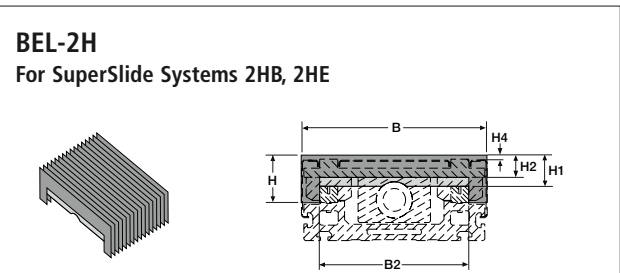

### BEL-2H Moveable Protective Bellows

Part Number	Nom. Sys. size	Dimension (mm)					
		B	B2	H	H1	H2	H4
BEL-2H-10	10	103	81	26	11	10	0
BEL-2H-20	20	199	167	48	30	15	5

Each moveable bellows comes with 1 section of bellows and 2 mounting brackets and mounting screws.

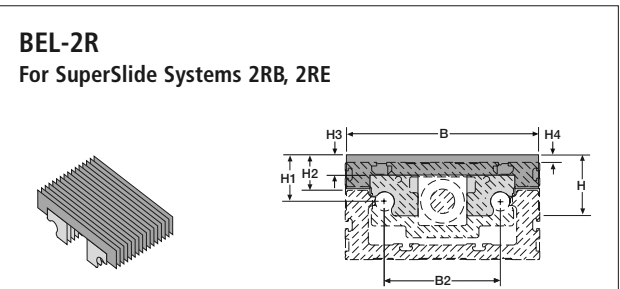

### BEL-2R Moveable Protective Bellows

Part Number	Nom. Shaft Dia.	Dimension (mm)						
		B	B2	H	H1	H2	H3	H4
BEL-2R-12	12	128	75	48	37	29	15	12
BEL-2R-16	16	158	95	52	426	30	150	10

Each moveable bellows comes with 1 section of bellows and 2 mounting brackets and mounting screws.

## Collapsible Bellows

Bellows will reduce available stroke length of slide by approximately 28%.

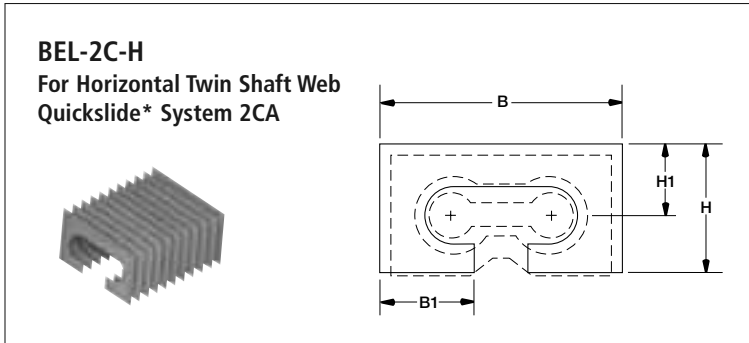

BEL-2C-H Moveable Protective Bellows					
Part Number	Nom. Shaft Dia.	Dimension (in.)			CR
		H	H1	B	
BEL-2C-08-H	1/2	1.688	1.031	3.250	.108
BEL-2C-12-H	3/4	2.062	1.156	3.812	.108
BEL-2C-16-H	1	2.437	1.281	4.62	.108

Each moveable bellows comes with 1 section of bellows and 2 pairs of Velcro® Fasteners.

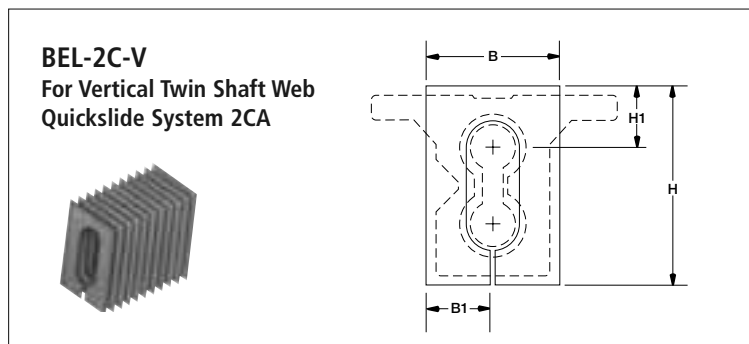

BEL-2C-V Moveable Protective Bellows					
Part Number	Nom. Shaft Dia.	Dimension (in.)			CR
		H	H1	B	
BEL-2C-08-V	1/2	2.750	1.000	2.125	.163
BEL-2C-12-V	3/4	3.750	1.125	2.375	.163
BEL-2C-16-V	1	4.375	1.250	2.625	.108

Each moveable bellows comes with 1 section of bellows and 2 pairs of Velcro® Fasteners.