

THE TORRINGTON COMPANY

BEARING FAILURE
PREVENTION GUIDE

Introduction

Bearing Life Expectancy 2

Safety Recommendations 2

Service Damage Terminology 3

Bearing Failure Terminology 3

Identification, Cause and Preventive Measures

Fatigue Failure 4, 5

Contamination 6, 7

Brinelling 8, 9

False Brinelling 10, 11

Thrust Failures 12, 13

Misalignment 14, 15

Electric Arcing 16, 17

Lubrication Failure 18, 19

Miscellaneous Failures 20, 21

Torrington Catalogs, Sales Offices, Product

Catalogs Available from The Torrington Company 22

Life Expectancy

Bearing life expectancy based on material fatigue can be calculated if the operating loads and speeds are known. These calculations must assume that the bearing is correctly mounted, lubricated and otherwise properly handled. It cannot take into consideration the effect of adverse operating conditions.

Bearing failures not attributed to material fatigue are generally classified as premature. The majority of premature bearing failures are caused by:

- Faulty mounting
- Improper lubrication
- Contamination
- Improper handling
- Improper maintenance

Great savings in time, effort and expense can be effected if the bearing user can establish the reason for premature failure and undertake corrective action to prevent further failure.

With this in mind, The Torrington Company has published this guide to help maintenance and quality control

personnel identify and correct some of the more commonly encountered failures. It is beyond the scope of this guide to discuss the complexities of metallurgical failure. There always will be situations that are ideally suited for our highly trained Field Service Engineers, Sales Engineers and Corporate Analytical Engineering Teams.

But the mechanical diagnosis of failure can be outlined and this publication should serve as a guide for the determination and correction of such failures.

There are many reasons for bearing failure, and usually each failure is due to a combination of causes, not just a single cause. In the following pages the major categories of failure will be covered, photographic examples will be shown, similar names for each cause will be listed, and identification, cause and preventive measures for each category will be discussed. Diagrams and line drawings are also included to support the written material.

It is The Torrington Company's hope that this guide will aid you in cutting needless expenditures of time and funds in the maintenance of machinery's most important single component – the bearing.

Safety Recommendations

- Store product in a dry and clean area.
- Do not open package until ready to use.
- Prior to installation, consult Torrington Company recommendations. Proper installation and maintenance must be adhered to for ultimate performance.
- Failure to adhere to recommendations may result in premature product failure, and/or in extreme cases, personal injury.

Service Damage Terminology

Abrasive Wear

Surface wear resulting from the lapping action of abrasive contaminants. The affected areas usually appear frosty gray; however, they may be highly polished if the abrasive particles are extremely small.

Brinelling

Permanent deformation of the bearing surfaces where the rollers (or balls) contact the races. Brinelling results from excessive load or impact on stationary bearings. It is a form of mechanical damage in which metal is displaced or upset without attrition.

Corrosion

Rust (corrosion) is the chemical attack of the bearing metal, almost always consisting of, or accompanied by, oxidation. It may cover a large or a small area, or be limited to a well-defined line, such as the line of contact between a roller and a race in a stationary bearing.

False Brinelling

False Brinelling of needle roller bearings is actually a fretting corrosion of their raceway surface. Although its appearance is similar to that of Brinelling, False Brinelling is characterized by attrition of the steel, and the load on the bearing is less than that required to produce the resulting impression. It is the result of a combination of mechanical and chemical action that is not completely understood, and occurs when a small relative motion or vibration is accompanied by some loading, in the presence of oxygen.

Flaking

See Spalling.

Fretting, Fretting Corrosion, Friction Oxidation

These terms all describe a type of service damage that occurs under the same conditions as False Brinelling.

Red and black oxides of iron are usually evident. In bearings, fretting usually takes place at the I.D. or O.D., but it may occur anywhere there is a close fit with some movement.

Galling

See Scoring.

Heat Checks

Surface cracks resulting from heat generated by sliding contact with another part. Heat checks are oriented normal to the direction of motion. Depending on the stresses present in the component, the cracks may remain small or become nuclei for a complete fracture.

Indentations

The surface depressions caused by debris or foreign material.

Pickup

The welding and transfer of metal between rollers and raceways during bearing operation. Pickup results from inadequate lubrication.

Pitting

Small, roughly circular holes or craters resulting from corrosion, mechanical damage, or the passage of an electric current. Because these three types of pits have distinctly different causes, the word *pitting* should always be qualified.

Scoring, Scuffing, Seizing, Smearing

All terms referring to transfer of metal from one component of a bearing to another under sliding contact. This process, which is also called galling, is caused by lack of adequate lubrication under extreme unit pressure.

Spalling

A breaking away of metal from the raceway or rolling element in flakes or scale-like particles. Also called flaking.

Bearing Failure Terminology (Cross References)

Fatigue

- Flaking
- Spalling
- Pitting
- Peeling
- Surface Erosion
- Microcracking
- Inclusion Origin Fatigue
- Subsurface Fatigue
- Macro Spalling
- Rolling Contact Fatigue

Brinelling

- Denting
- Indentation
- Impact Denting
- True Brinelling

Misalignment

- Skewed
- Cocked
- Warped
- Tilted
- Shaft-deflection
- Non-Tangent
- Non-Square
- Out-of-Round
- Shaft-Slope

Electric Arcing

- Fluting
- Corduroying
- Electro-etching
- Electric Discharge Damage
- Electric Erosion
- Electric Arc Pitting
- Corrugation
- Electric Pitting

Contamination—Debris

- Pitting
- Bruising
- Denting
- Scoring
- Glazing
- Indentation
- Debris Damage
- Roughening
- Scratching
- Rollover of Debris
- Abrasion Failure

Thrust Failure

- Counterbore Failure
- Axial Failure

Lubrication Failure

- General
- Peeling
- Smearing
- Fine Grain Spalling
- Microadhesion
- Surface Erosion
- Seizure
- Pitting

Inadequate Viscosity

- Glazing
- Fine Grain Spalling
- Surface Erosion
- Surface Peeling
- Point Surface Origin (PSO) Fatigue
- Frosting

Incorrect Amount of Lubrication

- Burn-Up
- Churning Failure
- Heat Failure
- Coking

False Brinelling

- Fretting Wear
- Friction Oxidation
- Vibration Damage
- Fretting Corrosion
- Vibration Brinell
- Internal Fretting
- Fluting

Contamination—Moisture/Water

- Corrosion
- Water Etch
- Staining
- Black Acid Etch
- Rusting/Oxidation

Identification

Flaking or Spalling of the normally smooth raceway

Spalling is caused by a granular weakening of the bearing steel. The failure begins as a small fracture of the steel's internal structure. This fracture progresses (propagates) to the surface of the bearing where particles of metal flake away.

Noisy Running of the Bearing

Because of the rough surface and the loosened metal chips there will be an increase in bearing vibration and noise.



Flaking or Spalling of Raceway

Cause

Normal Duty

A bearing has a life expectancy which depends upon load and speed imposed on the bearing. Calculations, based upon laboratory testing and field experience, have been established to determine, as accurately as possible, the life span of a group of bearings of a given size. Fatigue failure is the result of a bearing living out its normal life span. The flaking of the races is the result of the combined effect of load and speed. In any rotating or oscillating bearing there is a constant flexing or deflection of the ring and the rolling element material under load. Speed determines how often the deflection occurs while load determines the actual amount of stress under which the bearing steel operates. Assuming good machine design, satisfactory lubrication and sound maintenance practices, it is load and speed that will, over a period of time, cause eventual failure.

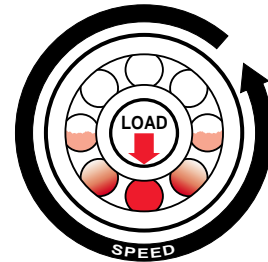

Normal Bearing Operation

Overload on the bearing

Premature failure of the bearings may result from the bearing being either radially or axially loaded beyond its normal capacity. Excessive operating load is not, however, the only reason for bearing overload. Overload may also occur due to abusive operating conditions. For example:

- If a bearing with insufficient internal clearance (space between rolling elements and races) is mounted on a shaft with an excessively heavy press fit, the bearing will operate with increased friction and torque — because with the outer ring held firmly, the inner ring has been expanded, “pinching” the rolling elements between the two rings.
- If the bearing housing is out-of-round, the outer ring will tend to conform to the shape of the housing. This will exert a localized pressure on the rolling element contact area, in addition to the normal pressure imposed by the operating work load.
- When a roller bearing is end loaded (due to misalignment, shaft slope, etc.) the load on the bearing is no longer uniformly distributed over the bearing's full width. This overloads a portion of the races and rolling elements resulting in localized fatigue.

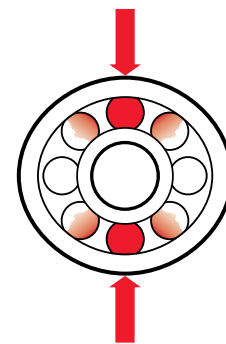

Outer Ring Squeezed by Housing

Non-Bearing Quality Steel

Roller bearings often operate on raceways supplied by the customer. Occasionally a raceway is made from a non-bearing quality steel. The raceway will then fatigue spall sooner than another raceway made from a “cleaner” bearing quality steel.

Preventive Measures

Normal Duty

The bearing has lasted its normal life expectancy; simply replace the bearing.

Overload Failure

Where overload is the cause of a premature fatigue failure, several alternatives are open:

- Redesign to permit incorporating a bearing with greater capacity. Many types of standard Torrington bearings such as needle roller bearings, cylindrical roller bearings, spherical bearings, extra-light, light, medium and double row series are available to fit the same shaft size. The heavier series have thicker ring sections and larger rolling elements for greater capacity. Also available for higher radial capacity is the maximum capacity type of ball-bearing, cylindrical roller bearing and spherical roller bearing. These bearings have certain similar bore dimensions, but all can accept more radial load — either because there are more rolling elements, larger roller elements or larger envelope dimensions. Certain restrictions will apply. The Torrington Company has resources available to help in any design situation.
- The load may be decreased to prolong the life of the bearing.
- Housings should be gaged for out-of-roundness and machined for proper symmetry and size. This insures that the outer ring will not be “pinched” or “squeezed”, resulting in an overload situation.
- If the failure is caused by an overload imposed by inner ring expansion, either the shaft fit may be made looser by regrinding it to the proper size or, in the event of thermal expansion, a bearing with a looser internal fit (more clearance between rolling elements and rings) may be recommended. Recommendations for shaft and housing fits are shown in the appropriate Torrington Company product catalogs.
- If the failure is caused by end loading, the cause of the end loading must be corrected. Recommendations on acceptable misalignment (shaft slope, etc.) is shown in the appropriate product catalog or can be easily supplied by a Torrington Company sales engineer.

Non-Bearing Quality Steel

Use steel that is listed as bearing quality for this particular application. Particularly avoid leaded and high sulfur content steels.

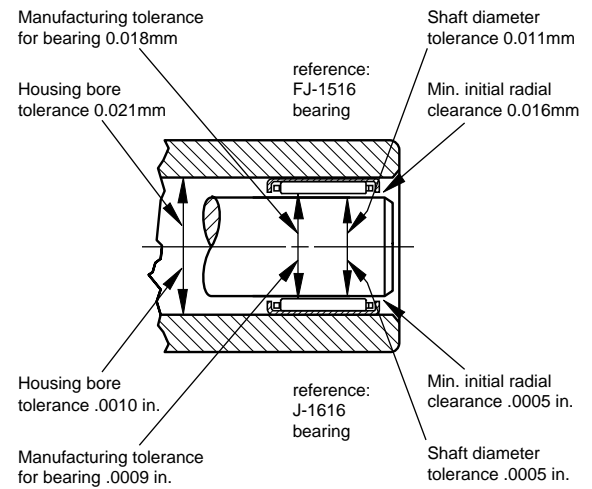

Manufacturing Tolerances and Built-In Clearances

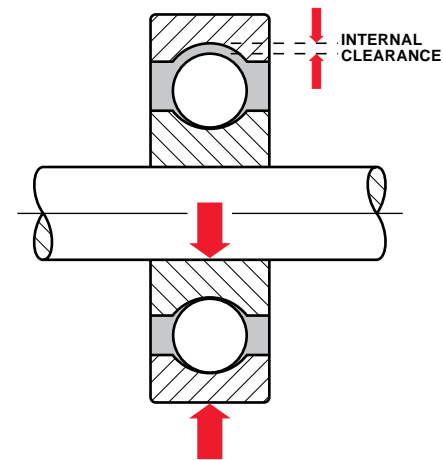

Bearing with a Looser Internal Fit May Be Recommended

Identification

Debris - Scoring, Pitting, Scratching

A failure caused by the entrance of foreign objects into the bearing may show a number of identifying marks. Where large particles of dirt or dust are present there will be scratches and pits around the periphery of the race with corresponding scoring of the rolling elements.

Where the contamination is in the form of very fine abrasives such as glass powder, graphite or dust impregnated lubricants, the impurities will act as a lapping agent, altering the appearance of rolling elements and raceway. This type of failure may be characterized by intermittent noise in the bearing. The actual presence of dirt in the bearing is the indication of this type of failure.

Rust

Where rust forms on the O.D. of the outer ring, it will not usually interfere with the bearing's performance in standard application, but rust in the bore is more serious because of the importance of inner ring-to-shaft fit. Rust in the raceways or on the roller elements precludes any further use of the bearings.

Moisture - Etching, Staining

If moisture is allowed to enter a bearing it can damage the bearing in several different ways. The internal surfaces may become corroded or etched. A stationary bearing exposed to moisture will probably show individual staining on the race in locations of contact between rolling elements and raceway; or random spots of corrosion on exposed surfaces. Either pattern of corrosion deters proper bearing performance and results in excessive noise, clearance, or the corroded zones may fatigue prematurely.



Examples of Scoring, Pitting and Scratching

Cause

Debris or Dirty Surroundings

Most bearing failures may be traced to some sort of contamination. Dirty working conditions are one of the bearing user's greatest problems. Thousands of dollars each year may be saved simply by taking certain precautions against the entrance of impurities into the bearings. Internal clearance in precision bearings is measured in the ten-thousandths (.0001) of an inch. Most dirt and particles are larger than one-thousandth (.001) of an inch, so hard particles will indent the race and the roller element surfaces when the bearing rotates.

Abrasive Waste Materials

In most applications such as; paper making, metal working, food processing, steel making etc., there will be an abrasive waste or by-product which infringes on the effective operation of bearings. This would also apply where coolants, washing solutions, acids or other liquids are used around a bearing application.

Moisture, Water

When water enters a bearing it can react with the lubricant or its additives (particularly EP additives) and form acids and other corrosive chemical compounds which attack the bearing surfaces. The most significant moisture damage occurs when the bearing is stationary because of the minimal lube film in the roller element's contact zones which leads to etching at point of contact. The water which entered the bearing could come from direct compromise of bearing or housing seals or from condensation due to environmental conditions.

Preventative Measures

Avoid Damage from Abrasive Waste Product

Where a manufacturing process involves an abrasive by-product, it is essential that the bearing be properly sealed. Where failures of this kind prevail, a more efficient seal is required. In applications where extreme contamination exists, a sealed housing or shroud may be incorporated into the design to protect the bearing. The Torrington Company also offers several coatings: TDC, TiN and MoS₂ which will protect as well as lubricate.

Clean Work Surroundings

The Torrington Company takes great care to provide bearings in as near pristine condition as possible: class 10,000 clean room assembly and inspection, pre-packed greases and oil-coatings, wrappings which prevent moisture seepage and superior boxing. Careful control of your area, tools, and clean dry hands are extremely important to prevent bearing failure. The following is a list of procedures outlined by the American Bearing Manufacturers Association (ABMA) for the control of cleanliness in handling bearings:

- Work with clean tools in clean surroundings.
- Remove all outside dirt from housing before exposing bearings.
- Handle with clean, dry hands.
- Treat a used bearing as carefully as a new one.
- Use clean solvents and flushing oils.
- Lay bearing out on clean paper and cover.
- Protect disassembled bearings from dirt and moisture.
- Use clean, lint-free rags if wiping bearings.
- Keep bearings wrapped in oil-proof paper when not in use.
- Clean inside of housing before replacing bearings.
- Install new bearings as removed from packages.
- Keep bearing lubricants clean when applying and cover containers when not in use.

Moisture Entry

Consult your Torrington Sales Engineers for the optimum seal configuration for your application. External seals may be required on a specific case basis.

When the entry of moisture cannot be prevented, regular relubrication is necessary to purge the contaminated grease from the bearing and replace it with fresh grease.

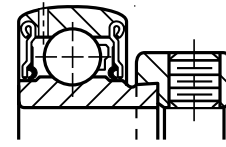

PLYA Seal

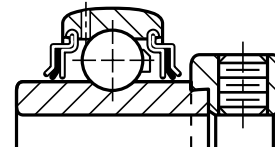

"R" Seal

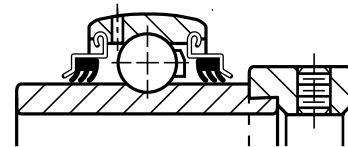

Tri-Ply Seal

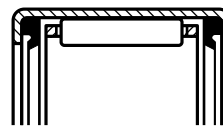

Needle Bearing Seal

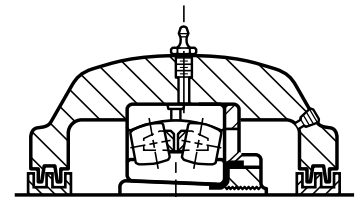

Sealed Pillow Block Housed Roller Bearing

Identification

Mounting indentations (thrust force) - Ball Bearings

This failure will appear as tiny indentations (sometimes barely discernable to the naked eye) high on the shoulder of the race. The dents will be angularly spaced in correspondence to the rolling element spacing. There will be a corresponding indentation of lesser magnitude on each rolling element.

When the bearing is radially loaded the brinells on the race shoulder may not interfere with the roller tracks. In this event, the dent on the rolling element will cause the failure. In the later stages of failure, spalling or chipping may result. The race shoulders can be inspected (with a microscope if available) to see if a spalling pattern may have resulted from initial brinelling. The term brinell comes from the mark on the bearing looking like the mark left from a brinell hardness testing machine.

Radial Indentations (radial force) - Ball Bearings

The indentations have the same general appearance as mounting indentations except that they appear in the center of the race instead of on the shoulder. This type of brinell is less common than the mounting brinell because, under the sharp impact of radial shock load, the rings may fracture beneath the force.

Radial Indentations (radial force) - Roller Bearings

In a uniformly loaded (no shaft slope or end load) roller bearing indentations appear as even, full contact lines the length and shape of roller. When an end load is present the marks will deepen at the end and the mark may not extend for the full length of the roller. As with all true brinell marks the surface manufacturing marks are visible in the indentations.



Example of Mounting Indentation

Cause

Force incorrectly exerted - Ball Bearings

Indentations high on the race shoulder are caused in mounting (or dismounting) where force is applied against the unmounted ring. When mounting a bearing on a shaft with a very close fit, pushing of the outer ring will exert an excessive thrust load bringing the rolling elements into sharp contact with the race shoulder, causing brinell.

Radial shock load - Ball and Roller Bearings

Radial indentations are caused by a shock load or static overload imposed radially on a non-rotating bearing. This may be imposed by hitting the bearing with a hammer or by an operating shock load exerted on a static shaft.

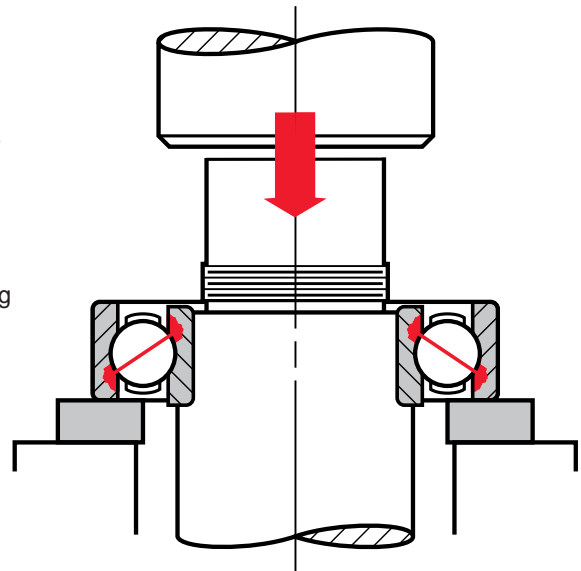

Incorrect Arbor Press Dismounting

Preventative Measures

Proper Mounting Procedure

In mounting a bearing, force should always be exerted against the ring being mounted. In other words, when mounting the bearing on a shaft, the pressure should be applied against the inner ring. When mounting in a housing, press against the outer ring. The ring having the tighter fit (usually the ring which will rotate in application) should be pressed.

Be sure when mounting a bearing to apply the mounting pressure slowly and evenly.

Operation

Identify source of overload on bearings and eliminate. It must be determined first if it is shock loading (dynamic loading) or static overload.

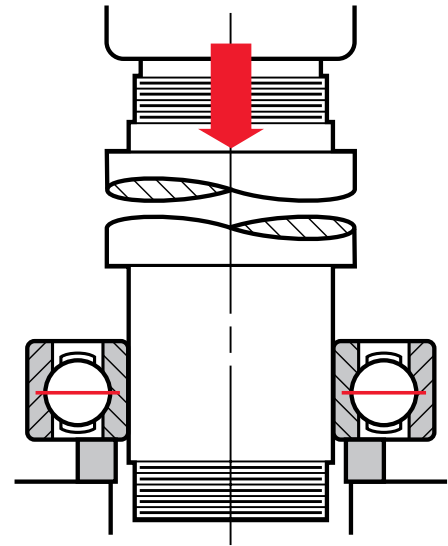

Proper Mounting Procedure

Identification

Axial Indentations – Ball Bearings

This type of brinelling will appear as elliptical impressions which run axially across the races. There will be a build-up of reddish lubricant around each brinell. Also, the brinells will be spaced with the corresponding roller element.

Circumferential Indentations – Ball Bearings

This will appear exactly as the brinelling above, except that the impression will be wider in a circumferential direction.

Roller Indentations – Roller Bearings

In a roller bearing, false brinell impressions look similar to the ‘true’ brinells produced by overload or shock load. They appear as roller shaped indentations in the raceway. However, careful examination will reveal the original surface manufacturing marks have been worn away in the false brinell indentation. This indicates the impression was formed through attrition.

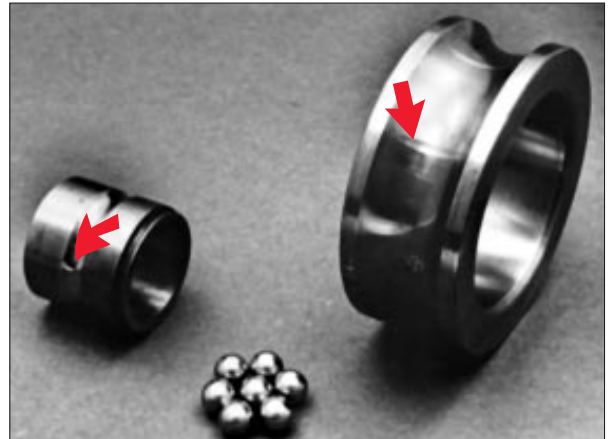

Examples of Axial Indentations

Cause

Vibration in a Static Bearing

False Brinelling is caused by the vibration of the rolling elements between the races (or themselves in a full complement bearing) in a stationary bearing. This vibration may be axial or circumferential. The appearance of the brinells will tell you which. As the roller element vibrates between the races, the lubricant is forced out of the contact area between roller and race. The failure is the result of a breakdown of the lubricant causing metal-to-metal contact and localized wear of rollers and races. The wearing action causes the formation of a fine reddish-brown powder (iron oxide). The oxide impregnates the lubricant and provides an abrasive compound that will polish (lap) the rollers and races if the bearing is put into operation. The indentations themselves will result in a rough and noisy operating bearing. Vibrations in a bearing may be caused by a number of factors which result in false brinelling. Two common causes of this failure occur:

- when mounted, but unlocked bearings are transported.
- when the bearings in a non-operating machine are subjected to the static vibration by other machinery operating in the area.

Small Angular Oscillation

When a bearing does not rotate through a large enough angle, so one rolling element can reach the previous resting point of the adjacent rolling element. Over time, this results in a depletion of lubricant from the contact zone, and failure proceeds as outlined above in: “Vibration in a Static Bearing.”

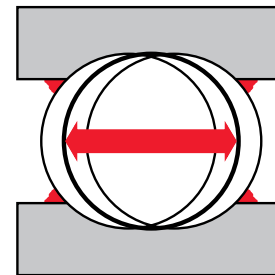

Axial Vibration

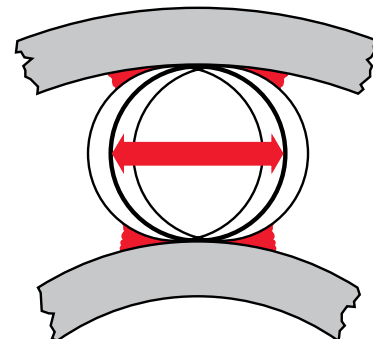

Oscillatory Vibration

Causes of False Brinelling

Preventative Measures

Vibration:

Correct the Source of Vibration

The source of agitation-loose parts, non-precision machinery, rough transportation, should be corrected so that vibration is avoided.

Locking the Bearing

When transporting bearings, apply a light thrust load (imposed by springs or rubber pads) to bring all of the rolling elements into contact with the races.

All Surfaces Adequately Lubricated

Where bearings are oil lubricated and employed in units that may not be in service for extended periods of time, the equipment should be set in motion periodically to spread the lubricant over all bearing surfaces. Intervals of one to three months should suffice.

Tighten Internal Fits

Sometimes a bearing with line-to-line contact between rings and roller elements will alleviate a false brinell failure. Great care should be taken, however, that a tight internal fit is satisfactory from an operations point of view.

Low Viscosity Lubricant

False brinelling is more common when stiffer lubricants are used. This failure is less apt to occur where oil or a light viscosity grease is used, because the liquid characteristics make it difficult for the lubrication to be forced out of the control area.

Oscillation:

Increase the Angle of Rotation

When possible, the application should be altered to increase the angle of bearing rotation, thus redirecting forces causing oscillation.

All Surfaces Adequately Lubricated

Bearings which are oil lubricated need a sufficient flow of oil to force wear debris away from the roller contact zone.

When grease is used - regular relubrication is required to purge contaminated grease from bearing.

Select Different Bearing Type

Depending on application, machinery, and environment, a different type bearing may be less susceptible to false brinelling. Please contact a Torrington Company Sales Engineer in your area for selections suited to your situation.

Identification

Maximum Capacity

Bearings with filling slots are not recommended for heavy thrust loading because, as the balls pass over the inner ring and outer ring notches, they may become nicked or dented. This in turn may cause spalling of the races (probably in the vicinity of the loading slot).

Counterbored Bearing

There will be a breakdown of the counterbored shoulder of the bearing which may result in the fracture of the ring. The balls will be banded from riding up against the shallow shoulder. Also the bearing may become disassembled during service.

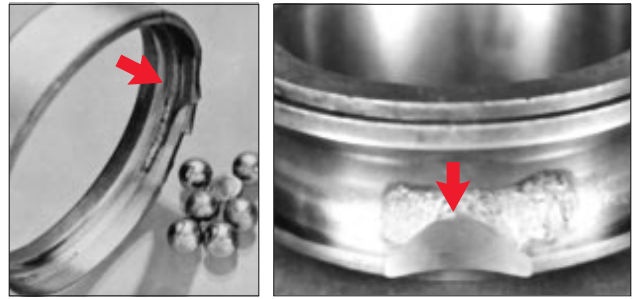

Examples of Thrust Failure

Cause

Improper Mounting or Misapplication as Indicated

Maximum Capacity Failure

This failure results from excessive thrust loads on a bearing not primarily intended for heavy thrust loads. The arrows in the diagram indicate that too much thrust load from either direction will cause interference between the rolling elements, and one of the loading slots which are ground in both the inner and outer rings.

Counterbore Failure

A thrust failure is caused either by mounting the bearing backwards (so that the load is carried against the shallow shoulder) or by putting a counterbored bearing into a bi-directional thrust application.

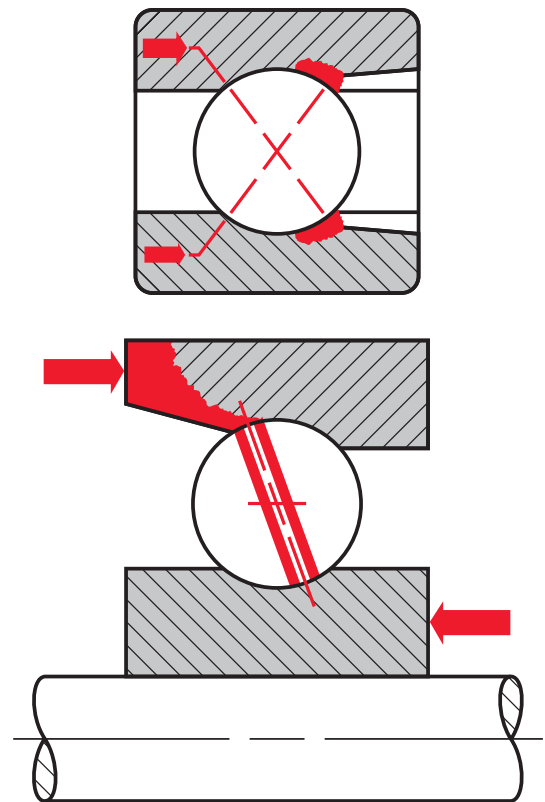

Incorrect Thrust Direction

Preventative Measures

Maximum Capacity Failure

A more suitable Conrad or angular contact type bearing must be selected if high or predominate thrust capacity is required. Obviously, the maximum capacity failure was caused by using a bearing using a bearing designed for heavy radial, or combined radial thrust loads; not for pure thrust loading. It is recommended that no more than 60 percent of the accompanying radial load on the bearing be applied in thrust.

Counterbore Failure

The remedy here is to mount the bearing correctly so that the balls have full shoulder support on both the inner and outer rings. Remember that the outer ring counterbore bearing will take thrust against the inner ring on the counterbored side of the bearing, and the outer ring on the side opposite the counterbore. The word THRUST will be stamped on the outer ring face showing the proper thrust surface.

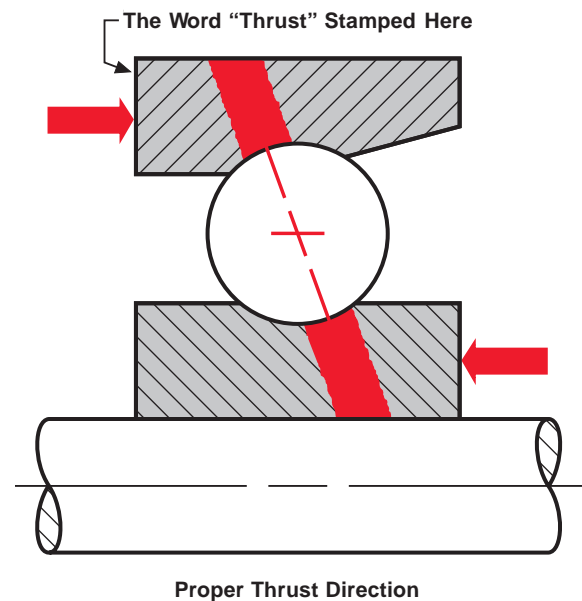

Identification

Ball or Roller Path

In a bearing with one side misaligned in relation to the other, the ball or roller path will run from one side of the race to the other around one-half of the circumference on the non-rotating ring. The rotating ring will have a wide roller path. Because of the extra pressure imposed on the bearing due to misaligned conditions, an excessively high temperature may develop which will discolor the raceways and the rolling elements while destroying the lubricant.

Retainer

The purpose of the retainer is to space the rolling elements and to guide them in a true path around the raceway. Where a ring is misaligned, the rollers are driven up against the race shoulder and a stress point is established between the roller and its retainer pocket. The pocket will flex, increasing the possibility of retainer fracture in the advanced stages of stress.



Examples of Bearings with Misaligned Rings

Cause

Shaft Misalignment

Misalignment of the shaft in relationship to the housing causes an overload of the balls or rollers which will result in the failure described.

Housing Misalignment

Housing misalignment may be caused either by the housing being cocked in relation to the plane of the shaft or the housing shoulder being ground out-of-square so that it forces the outer ring to cock in relation to the inner. It may also be caused by the settling of housing frames or foundations.

Shaft Bowing

Shaft bowing may be caused by the following:

- As a result of improper handling
- Overhung load exceeding shaft capacity.
- Initial shaft bowing due to grinding inaccuracies.
- Shaft shoulders ground out-of-square with the shaft centerline which will, by cocking the inner ring, force a bowing of the shaft.

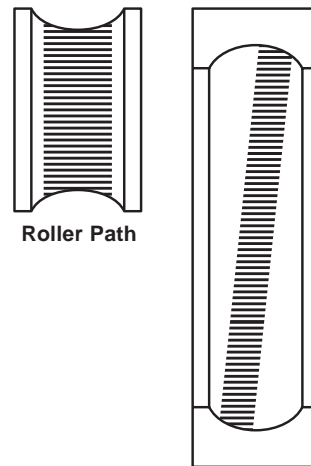

Roller Path

Examples of Ball Path Running from One Side of the Race to the Other Side

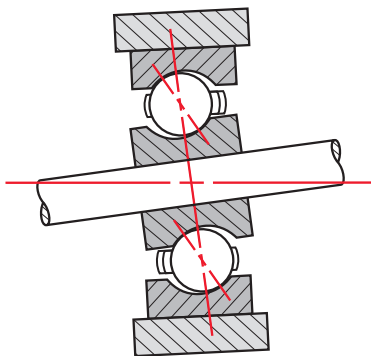

Shaft Misalignment

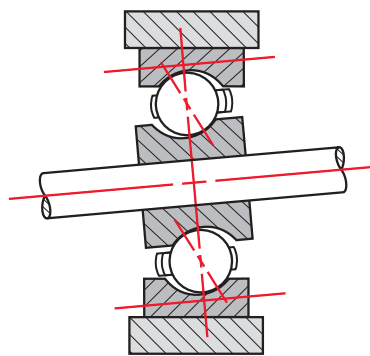

Housing Misalignment

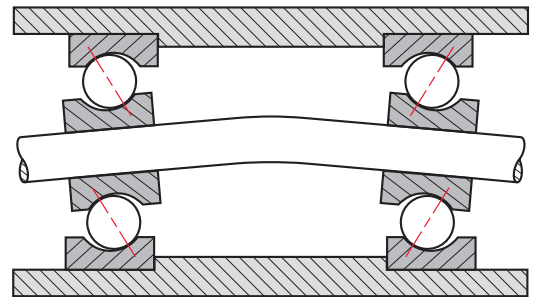

Shaft Bowing

Preventative Measures

Housing

The remedy is to dimensionally check and insure that both the housing bores are true to each other.

Shaft

The shaft should be gauged to make sure that is concentric and straight. Heavy overhang loads should be lightened or moved closer to the bearing. If the shoulders are out-of-square; they should be reground and gauged so that they are perpendicular to both the bearing seat and the shaft centerline.

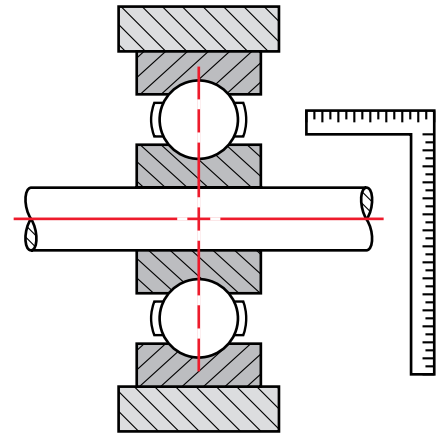

Both Housing Bores Must Be True to Each Other

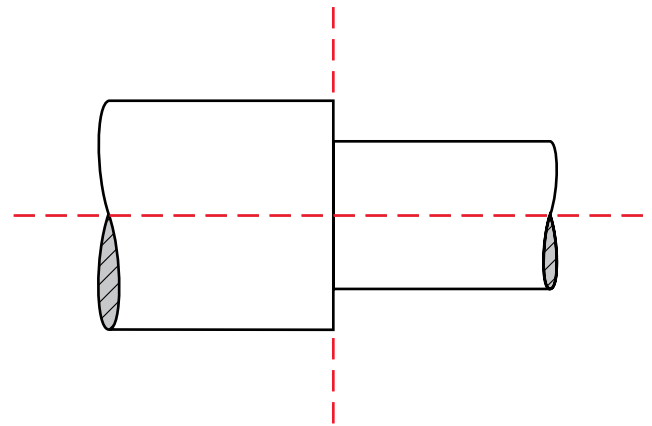

Squaring-Up Shaft Shoulders

Identification

Electric Arc Erosion

Arcing, which produces high temperatures at localized points, results when an electric current passing through a bearing is broken at the contact surfaces between races and rolling elements. Each time the current is broken in its passage between the ball or roller and race, a pit is produced on both parts. Eventually the phenomenon known as fluting develops, (see photograph). As it becomes deeper, noise and vibration result.

Granular Race Surfaces

If the current is of higher amperage intensity such as a partial short circuit, the next phase of the failure will show up as a rough granular appearance in the ball track.

Pitting or Cratering

Heavy jolts of high amperage charges will cause a more severe failure resulting in the welding of metal from the race to the ball or roller. These protrusions of metal on the roller will, in turn, cause a cratering effect in the race. This phenomenon will result in noise and vibration in the bearing.

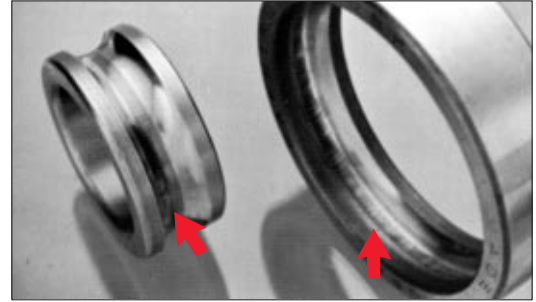

Electro-etching on Both Inner and Outer Ring

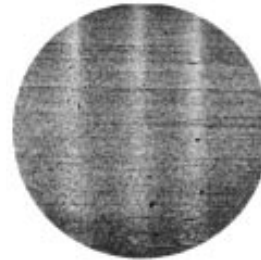

Magnification of Granular Race Surface



Magnification of Electric Pitting

Cause

Static Electricity

Static electricity usually emanates from charged belts or from manufacturing processes using calendar rolls (leather, rubber, cloth, paper). The current is carried from the belt to the pulley or sheave — from the sheave to the shaft — through the shaft to the bearing — and from the bearing to the ground.

Electric Leakage

Faulty wiring, inadequate or defective insulation, or loose rotor windings on an electric motor are all possible sources of current leakage. Either AC or DC currents will damage bearings.

Short Circuit

Wires which are crossed or contacted by a common conductor will cause a short circuit and may result in a passage of current through the bearing.

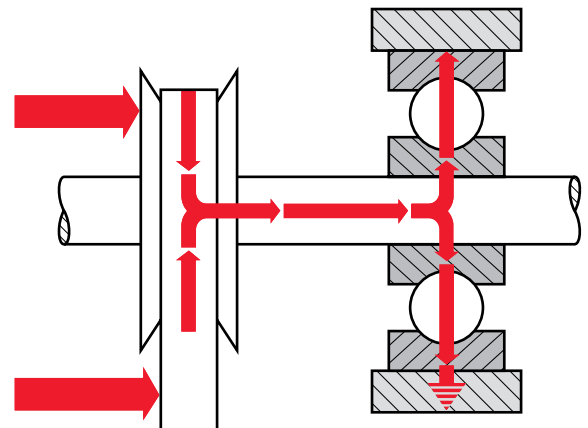

The Current Path

Preventative Measures

Shunts and Slip Rings

Where there is a passage of current through a bearing and the source of the current cannot be corrected, a shunt in the form of a slip ring assembly may be incorporated to by-pass the current around the bearing.

Corrective Maintenance

Be sure wiring, insulation, or rotor windings are sound and all connections are properly made. In arc welding, great care should be taken that the welding apparatus is not grounded on something that will circulate the current through the bearings.

Grounding Belts

To eliminate static charges, ground the belt, or change the belting to a less generative material.

Insulating Bearings

Sleeves of nonconductive material may be used either between the outer ring and housing or between inner ring and shaft, depending upon the source of current.

Conductive Grease

Utilizing an electrically conductive grease will provide a path for the current to minimize or cease damage to your bearings. Consult your lubricant supplier for availability.

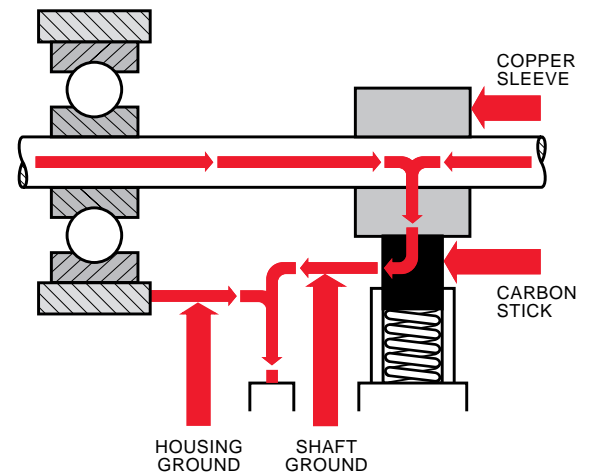

Use Sleeves of Non-Conductive Material Either Between the Outer Ring and Housing, or Inner Ring and Shaft

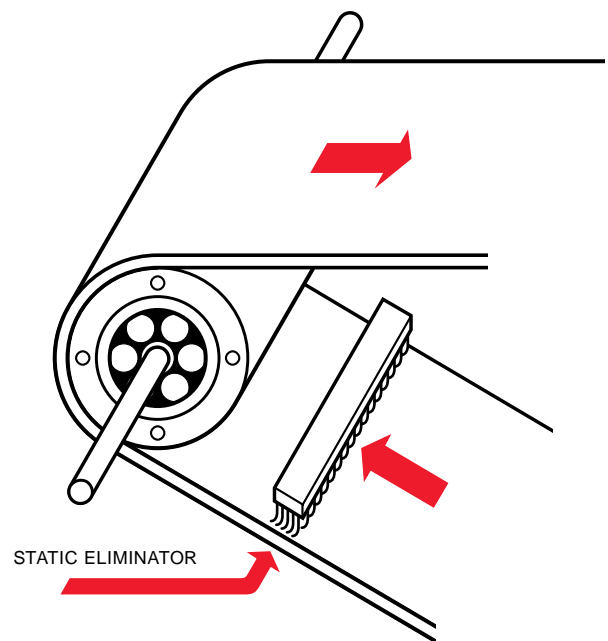

Ground Belts to Eliminate Static Charges

Identification

Grease Appearance

If the grease is stiff or caked and changed in color, it indicates lubrication failure. The original color will usually turn to a dark shade or jet black. The grease will have an odor of burnt petroleum oil. Lubricity will be lost as a result of lack of oil. In cases of Lithium base greases, the residue appears like a glossy, brittle varnish which will shatter when probed with a sharp instrument.

Abnormal Temperature Rise

Probably the first indication of lubricant failure is a rapid rise from the normal operating temperature. Test by hand is not necessarily conclusive since normal operating temperature may exceed the bearable limit of roughly 120°F.

Noise

Lack of lubrication is soon accompanied by a whistling noise coupled with the rise in temperature. If not corrected, the bearing temperature will continue to rise and the intense heating will reduce the bearing hardness.

Bearing Discoloration

A brownish or bluish discoloration of the races and rolling elements indicates that the bearing operating temperature was excessively high to the extent that the bearing lost its physical properties and was no longer operable.

The bearing part that first indicates distress in lubrication failures is usually the retainer where the greatest amount of rubbing action takes place.

Inadequate Viscosity of Lubricant

The surface of the bearing has lost its as-manufactured appearance and now has a frosted appearance. When examined under a microscope you will see that the surface has roughened and appears granular. Under some conditions the granular appearance is visible even without using a microscope. Occasionally some areas of the bearing will be highly polished.

Cause

Dirty Lubricants

Contaminants found in lubricants often act as an abrasive compound which will lap or polish roller and race surfaces, increasing the probability of early failure. The Torrington Company filters bearing lubricants as many as five times to insure their purity.

Too Much Lubricant

A very common error in the maintenance of machinery is the tendency to over-lubricate. If the bearing reservoir is kept constantly full of grease, the friction heat developed within the lubricant will cause its own rapid deterioration.

Inadequate Lubrication

Heat will result from under-lubrication, also. Where there is inadequate lubricant to cover all metal surfaces, friction will result in heat-up of the bearing.

Wrong Kind of Lubricant

Selection of the correct lubricant is very important in achieving maximum efficiency and endurance from the bearing application.

After experimentation with many types of lubricants, the equipment manufacturer recommends those which he feels will provide ideal lubrication life under given operation conditions. Insofar as availability allows, you should use the same lubricant or its equal. Thus you are assured of using the correct lubricant, in addition to avoiding the problems associated with mixing two types of grease.

Many greases are incompatible and, although completely adequate when used individually, may prove unsatisfactory when mixed.

Other Failure Modes

The primary cause of lubricant failure is from the high temperatures developed when excessive loads overpower the lubricant film.

In many instances lubricant failure will accompany the bearing failures described in this manual. Lubricant changes might reduce the failure rate but the proper cause of action is to eliminate the primary cause for the lubricant breakdown.

Inadequate Viscosity of Lubricant

The viscosity of the lubricant was inadequate to properly separate the bearing surfaces.

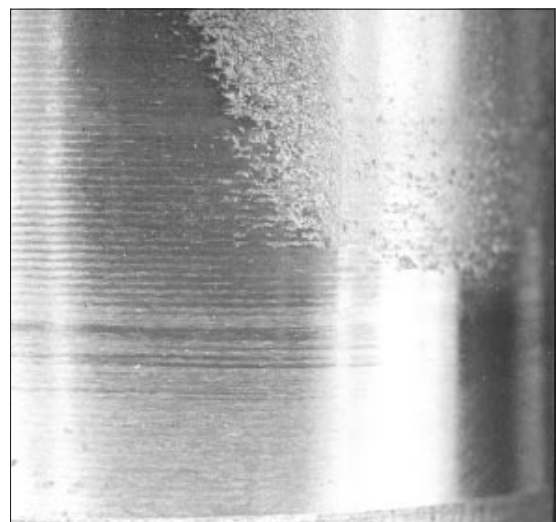

Preventative Measures

Avoiding Dirty Lubricant

Always keep grease containers covered. Dust particles in the air can contaminate the lubricant. Use a clean, rust-resistant spatula for relubricating open bearings. When relubricating bearings through a grease fitting, always wipe off both the fitting and nozzle of the grease gun. Any steps which you can take to keep lubricants clean will pay off in longer bearing life.

Amount of Lubricant

The Torrington Company Engineering Department should be contacted when you are unsure of the amount of grease or oil for proper lubrication. In standard applications, it is generally recommended that the bearing should be greased one-third to one half full.

Inadequate Viscosity of Lubricant

Select a lubricant with sufficient viscosity to properly separate the rolling contact surfaces. Typically, we recommend a lubricant with a viscosity of at least 100 SUS (20 cSt) at the bearing operating temperature. If an application's lubricant does not meet the bearing's viscosity requirements and a lubricant with a greater viscosity cannot be substituted, improved cooling of the current lubricant may lower its operating temperature (and thus increase its viscosity) enough to obtain acceptable bearing life. Similarly, improving the surface finish on customer supplied races may allow the current lubricant to separate the rolling contact surfaces.

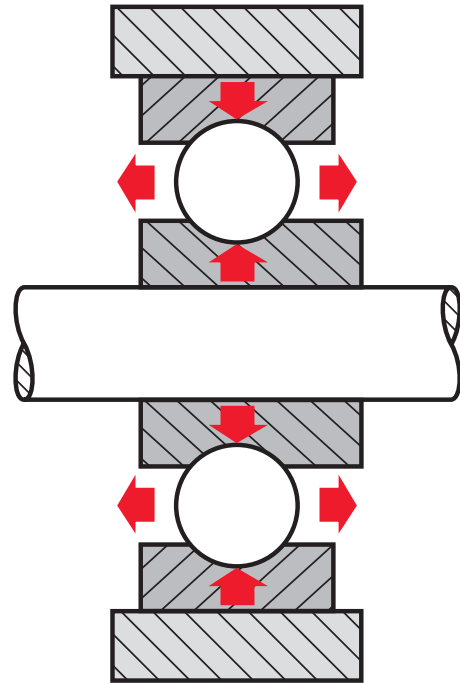

Lubrication Failures in Ball Bearings Are Usually Accompanied by a Thermal Expansion of the Components

Cam Failure – Wide Inner Ring Ball Bearings

Identification:

Broken cam, misaligned travel path, bearing will wobble.

Cause:

Undersize shaft, outer ring unable to align due to housing.

Preventive Measures:

Correct the shaft size, use the Fafnir self-aligning feature – a spherical outer ring to compensate for initial misalignment and correctly mount bearings. The proper mounting procedure is to:

- Align the bearing in its housing and slide unit into position on the shaft
- Bolt the housing tightly to its mounting support
- Engage and tighten locking collar and setscrew.

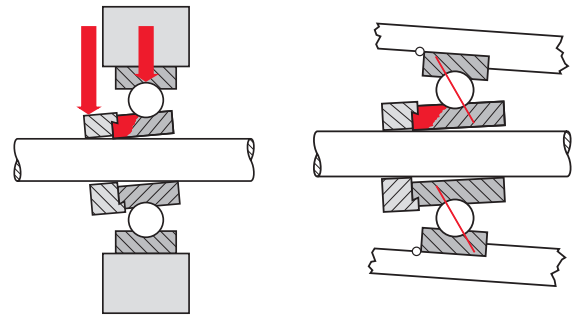

Shaft Below Suggested Tolerance Levels

Misaligned Outer Ring

Roll Out (Sub Case Yielding, Case Crushing)

Drawn Cup Bearings, or other case hardened races

Identification:

Circumferential cracks in the load zone.

Cause:

Overload

When a bearing is grossly overloaded, the stress is driven deep into the race. If it is a case hardened race, the stress may then exceed the strength of the relatively soft core. When this happens the race's core will plastically deform in the axial direction. (It is constrained in the radial direction by the housing.) As the core expands axially, it carries the case with it causing the case to fracture circumferentially.

Attrition

If a case hardened race is subjected to severe wear, the case can wear away. The stress from a normally loaded bearing then will reach the core, and cause roll out as described above.

Preventive Measures:

Overload

Eliminate the source of the overload or change to a bearing with greater capacity.

Attrition

Correct the cause of the wear.

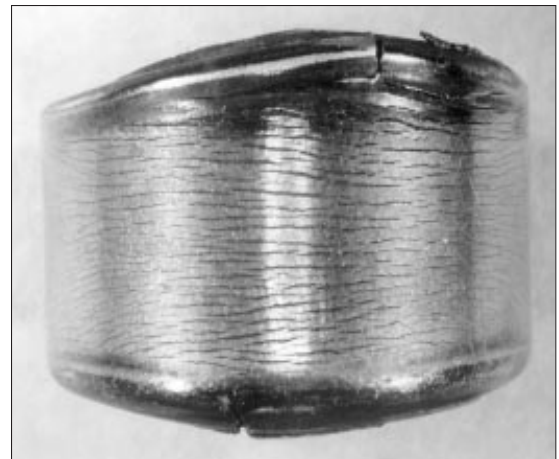

Preventative Measures

Identification:

Rollers locked in place, large smeared flat on many rollers and severely discolored (black, blue) bearing components.

Cause:

The pilot in the installation tool used to install the full complement bearing did not have a functional ball detent.

In shipping, a full complement bearing's rollers often settle into a slightly skewed position. If the bearing's rollers are not aligned prior to pressing the bearing into the housing, the rollers will lock in place at installation. The shaft then skids on the locked rollers resulting in smeared flats.

Preventive Measures:

Install/replace ball detent on pilot portion of installation tool.



Identification:

Bearing's lip fractured off.

Cause:

The installation tool used to install the bearing is lacking the required 15° backangle.

Without the 15° backangle the installation force is directed through the lip of the cup and will fracture it. Often the lip is only cracked at installation and then breaks free in service. When a 15° backangle is used, the installation force is directed through the cup's wall, eliminating the possibility of fracturing the cup's lip.



Preventive Measures:

Fabricate an installation tool with a 15° backangle.

- A $\frac{1}{64}$ " (0-4 mm) less than housing bore
- B .003" (0.06 mm) less than shaft diameter
- C distance bearing will be inset into housing; minimum of .008" (0.2 mm)
- D pilot length should be length of bearing less $\frac{1}{32}$ " (0.5 mm)
- E Approximately $\frac{1}{2}$ D

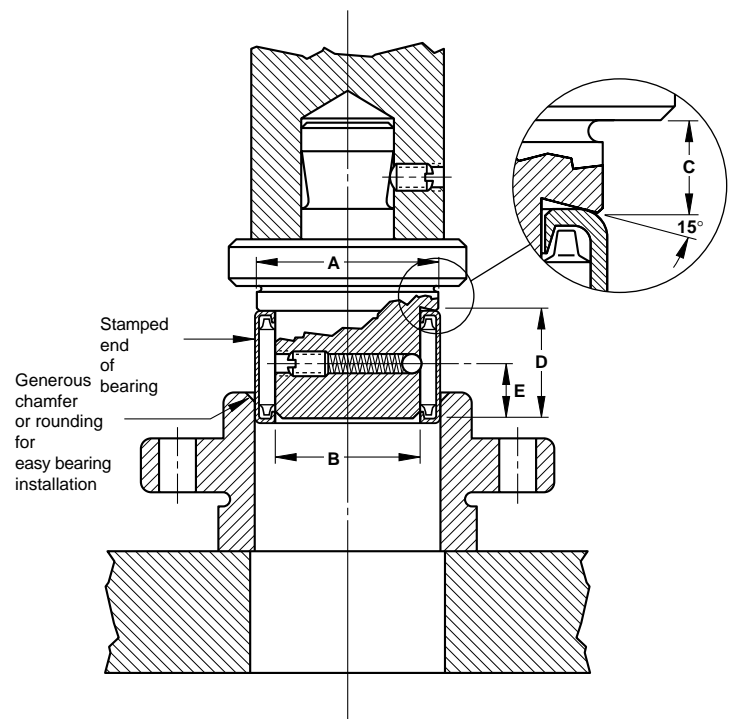

Tool with 15° Backangle, for Drawn Cup Bearing Installation

There are many more failures which are usually combinations of what has been discussed, or shown, in this brochure. If you require any further information, please do not hesitate to utilize our vast resources; engineering, material processing, analysis and utilization. Contact our sales engineers at the locations on the page 24.

The Torrington Company Catalogs

The Torrington Company offers the following publications to provide you with additional information about its bearing product line.

While these publications are not to be considered as containing sufficient data for all bearing selections, they can provide valuable assistance in your initial considerations of the type and characteristics of the bearing which may be most suitable for your particular needs.

Torrington's highly trained sales engineers are available to work with you to make sure you have selected the best Torrington bearing for your application. See the last page of this manual for the phone number and address of the Torrington Engineering Sales Office nearest you.

Catalogs

The Torrington Company Service Catalog

An overall view of Torrington®, Fafnir® and Kilian® bearing products **No. 100**

To Order These Catalogs

Contact your nearest Torrington Company Engineering sales office. See listing on page 24.

The following product catalogs present additional in-depth information on each product line:

Torrington® Needle Roller Bearings No. 101

Fafnir® Superprecision Ball Bearings No. 102

**Fafnir® Wide Inner Ring Bearings and
Housed Units No. 104**

**Fafnir® Radial and Angular Contact
Ball Bearings No. 105**

**Torrington® Large Bearings, Roller, Ball
and Pillow Blocks No. 106**