

Spherical Plain Bearings

Nomenclature

Introduction	342-345
Lubrication (SF, SBT)	346
Temperature	346
Tolerances	347
Radial Bearings, Type SF	348, 349
Angular Contact Bearings, Type SBT	350, 351

Spherical Plain Bearings

One or two-digit "Series" number. The number is read as an actual bore (i.e., 10 is 1.00") or an approximate bore (i.e., 17 is 1.75")

7

SF

SF spherical plain type ; Single fractured outer ring
SBB spherical plain type ; Double fractured outer ring
SBT spherical plain angular contact type

Seal Designator:

TT reinforced rubber seals
SS synthetic resin seals

12

-

SS

One or two digit number indicating the exact bore size in 1/64ths of an inch (i.e., 12 refers to 12/64" bore which is 3/4" bore).



INTRODUCTION

The Torrington Spherical Plain bearing has a spherically shaped inner ring with a ground cylindrical bore for shaft mounting. The cylindrical outer surface of the outer ring permits convenient mounting in a housing.

Torrington Spherical Plain bearings offer the following advantages to the designer:

- High capacity
- Ability to accommodate misalignment
- Superior performance in low frequency oscillating applications
- Simplified housing and shaft design
- Easy installation
- Radial types available with seals

For all types of Spherical Plain bearings both the inner and outer rings are manufactured from through-hardened steel and are precision ground.

The dimensional data list Spherical Plain bearings successively by larger bore sizes.

The Torrington Company also supplies Spherical Plain bearings made to special design. These include standard design bearings made with special materials, clearances, and finishes or bearings with special configurations such as extended inner rings.

Before selecting individual bearings, please review the following text concerning design and application.

All new applications of Torrington Spherical Plain bearings should be reviewed by the Torrington Fafnir Engineering Department.

GENERAL FEATURES

Metal on Metal Bearings

Rings are phosphate treated and coated with molybdenum disulfide (MoS₂) to minimize friction of contacting surfaces.

These bearings are available as radial types (SF series) and angular contact thrust (SBT series).

SF series has lubrication holes and grooves in both inner and the outer rings, permitting relubrication through either shaft or housing.

SBT angular contact type has lubricating holes and grooves in the outer ring for relubrication through the housing.

SF series is available with integral seals as SF...TT and SF...SS, which incorporate lip seals designed to retain lubricant and protect the spherical surfaces from external contamination.

BEARING TYPES

SF

These bearings are designed primarily to carry radial loads and handle moderate misalignment. The outer ring is usually fractured axially in one place, parallel to its axis, to permit assembly of the bearing rings, which do not have loading slots.

These types can also be supplied with double-fractured outer rings (designation SBB) when this feature is desired for easier assembly in this application. To facilitate handling, a snap ring is usually supplied to hold the outer ring halves together.



SF

SF...TT, SF...SS

These bearings are dimensionally interchangeable with and have the same general characteristics as the SF series and incorporate lip seals.

The seals are securely retained in the outer ring and will withstand high grease pressures during relubrication. Positive retention of the seals assures full distribution of the lubricant to all bearing surfaces. SF...TT incorporate two reinforced nitrile rubber seals. SF...SS are assembled with synthetic resin seals. Operating temperatures of the seals should not exceed 212°F (100°C).



SF



BEARING TYPES (continued)

SBT

These bearings are designed for single direction thrust loading and some misalignment. Inner and outer rings are separable. The raceways are essentially hemispherical, and the rings are designed to provide maximum spherical raceway contact in the axial direction.



SBT

INTERNAL CLEARANCES

Radial internal clearance is defined as the total possible movement of the inner ring relative to the outer ring in a radial direction. Axial internal clearance is the total possible movement of the inner relative to the outer ring in an axial direction.

Radial internal clearances listed for the SF series are for finish ground, unmounted bearings prior to fracture of the outer ring. The molybdenum disulfide coating reduces this clearance by a maximum of .002 inch (.05mm). The maximum interference fits using recommended housing and shaft dimensions will maintain a satisfactory minimum internal clearance in the mounted condition, accommodating coating thickness, outer ring compression, and inner ring expansion.

LOAD RATINGS

Dynamic Load Ratings

SF

The dynamic load rating listed in the tables of dimensions is based on a maximum stress level of 85 megapascals (approximately 12,300 psi) between the sliding contact surfaces. It is the maximum load recommended for bearings subjected to intermittent operation with periodic lubrication.

The dynamic load rating is based on the radially projected area of the inner ring bore under the condition where, with the recommended fitting practice and periodic lubrication, rotation normally takes place.

For intermittent loading and operation, the applied radial load should not exceed the dynamic load rating. For constant loading and continuous operation, the applied radial load should not exceed 75% of the dynamic load rating. For dynamic or static thrust loading, use 25% of the respective radial load rating value. For combined radial and thrust ratings consult Torrington Fafnir Engineering.

SBT

The dynamic load rating is based on the same stress levels as **SF** shown above and is the maximum thrust load recommended for extended life with periodic lubrication. It is based on the axially projected area of the spherical surfaces in contact. Where the shaft shoulder supports high thrust loads, it is recommended that hardened shafts be employed.

Equivalent Thrust Load

SBT

For combined radial and thrust loading under intermittent dynamic conditions, the equivalent thrust load (T_e) must not exceed the dynamic load rating. For constant loading and continuous operation, the equivalent load (T_e), or the axial load (T) when the radial load (R) is zero, must not exceed 70% of the dynamic load rating:

$$T_e = T + 1.4R$$

T_e = Equivalent thrust load per bearing

T = Applied thrust load and/or preload

R = Applied radial load per bearing

The **limit load rating** of all spherical plain bearings listed is the maximum static load that can be applied to the bearing. This load should not be exceeded. The ultimate, or static fracture rating of the bearing is at least 1.5 times the limit load rating.

Shaft and housing stresses should be checked when the applied load approaches the limit load rating since the shaft or housing may then become the critical member.



MISALIGNMENT

In many applications, the degree of misalignment of the radial types of Spherical Plain bearings is determined by the side clearance between the yoke and the bearing housing as illustrated.

When the bearing is mounted without such restrictions, a larger misalignment can be accommodated. α is the maximum angle of misalignment for sealed bearings as illustrated. If α is exceeded, the seal lips will slide off the spherical surface. Seal effectiveness is then lost and damage to the seal lip will occur if contact is made between the seal lip and shaft shoulder.

Greater misalignment under light to medium loads is possible with unsealed plain radial bearings as shown by angle α' . This requires limiting the shaft shoulder diameter to the recommended dimension (d_a) and also requires sufficient side clearance for the outer ring and housing.

Misalignment greater than α' reduces the load carrying ability of the radial plain spherical bearings. When extreme misalignment is contemplated, the strength of the shaft in shear and bending should be carefully checked, since the shaft support may be some distance away from the bearing.

The type **SBT** angular contact bearing permits a tilting angle α provided the housing shoulder clears the shaft. Such misalignment is limited by the bore of the outer ring touching the through shaft, as shown. A larger angle of misalignment is possible where a stub shaft is used. If the tilting angle exceeds α , however, the Torrington Engineering department should be consulted for recommendations.

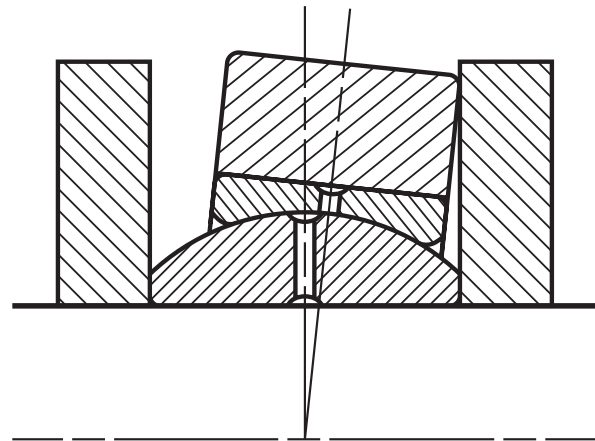

Side Clearance between Yoke and Bearing Housing

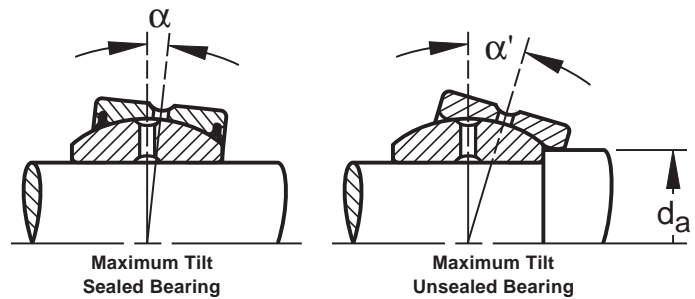

Maximum Tilt Sealed Bearing

Maximum Tilt Unsealed Bearing

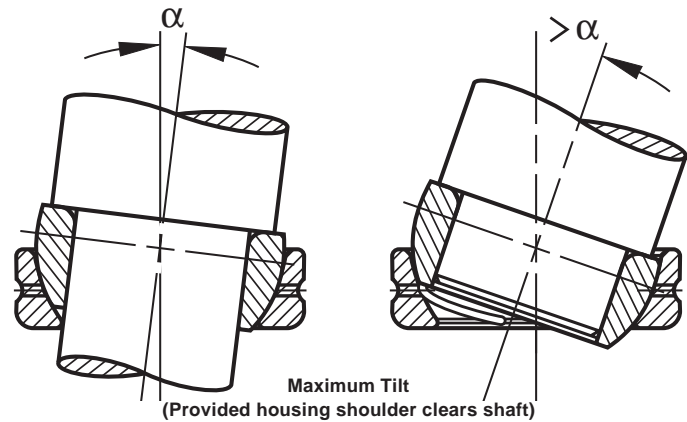

Maximum Tilt (Provided housing shoulder clears shaft)

HOUSING DESIGN

The housing should be strong enough to support the loads applied to the bearings without distortion or risk of fatigue failure.

When using a housing of the type illustrated, with a load applied in directions "X" or "Y", the compressive yield strength of the housing material should be greater than the applied load divided by $(B_a \cdot D)$.

When the load is applied in direction "Y", the yield strength of the housing in tension should be greater than the applied load times $K/B_a(D_a - D)$, where K is a stress concentration factor from Table 1.

The recommended housing bore tolerances closely approximate N7 tolerances. This produces an interference fit that ensures proper rounding of the outer ring. Light metal housings or housings with thin cross sections may require a tighter fit. An interference fit in the

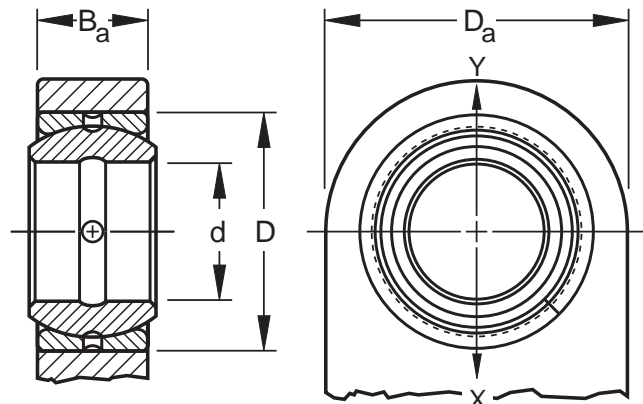



HOUSING DESIGN (continued)

housing is also necessary to prevent creeping by the outer ring with resultant wear of the housing bore and shoulder. Split housings should be avoided.

To resist thrust loads, the bearing should be mounted as shown in the mounting details above the table dimensions.

When Plain Angular Contact bearings (SBT) are axially loaded, the housing expands. For proper and safe bearing function, it is vital to provide a substantial section for the housing. If the thrust limit load ratings are applied for these bearings, not only should the section of the housing be generous, but the housing bore diameter (d_b) must not be exceeded. This not only supports the thrust load, but strengthens the housing in the radial direction as well.

The recommended housing bore for the type SBT Angular Contact bearing produces a tight transition fit.

Table 1 – Stress Concentration Factor

D_o/D	K	D_o/D	K	D_o/D	K
1.2	1.8	1.8	2.4	3	3.7
1.4	2	2	2.7	4	4.7
1.6	2.2	2.5	3.2	5	5.5

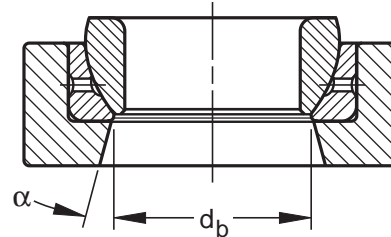

Housing Section - Angular Contact Bearing

SHAFT DESIGN

In applications with heavy radial loads, although alignment takes place at the spherical bearing surface, rotation or oscillation normally occurs between the bore of the inner ring and the shaft even though an interference fit may have been used. For this reason, and to facilitate assembly, the shaft dimensions listed in the tables should be used.

To obtain satisfactory performance with heavy loads or under abrasive conditions, the shaft should be hardened to 655 VPN or 58 Hrc minimum. Additionally, the shaft should have sufficient strength to withstand the applied loads in both shear and bending. The surface finish of the bearing seat should not exceed 0.8 micrometers (on the Ra scale) or 32 microinches aa (arithmetic average). The shaft should always be supported as close to the inner ring as possible to minimize bending.

When the loads are light, it is possible to prevent rotation between the inner ring and shaft by using an ISO m6 shaft tolerance or by clamping across the inner ring. Under these conditions, a fully hardened shaft is not necessary.

When the bearing is loaded axially, the load is transmitted between the end face of the inner ring and the adjacent shaft shoulder. The shoulder surface must be of sufficient strength and hardness not to deform permanently under load. If the inner ring is to rotate, the finish of this surface should not exceed 0.8 micrometers (on the Ra scale) or 32 microinches aa (arithmetic average).



LUBRICATION (SF, SBT)

The dry film lubricant (MoS_2) is sufficient for static applications and for relatively short periods of dynamic operation.

The bonds between the rings and MoS_2 coating is destroyed by any fluid including oils, greases and water. Any abrasive material present on the dynamic bearing surfaces will ruin the MoS_2 coating. Therefore, if the bearing is subjected to such operating or environmental conditions, it is necessary to relubricate frequently.

The radial bearings, both with and without seals, have lubricating holes and grooves in both the inner and outer rings, permitting relubrication through either the shaft or the housing.

The angular contact bearings have lubricating holes and grooves in the outer ring for relubrication through the bearing housing. The lubrication grooves in the spherical bore of the outer ring traverse a pattern designed to provide effective lubrication. These grooves extend into the small bore of the ring, permitting relubrication through the end of the housing as illustrated.

The relubrication cycle will depend on the magnitude of the load, frequency and amplitude of oscillation, environmental conditions and the effectiveness of the sealing used to exclude foreign materials from the bearing surfaces.

If bearings are relubricated, the dynamic load rating depends on the film strength of the added lubricant. High quality EP greases are recommended for best results.

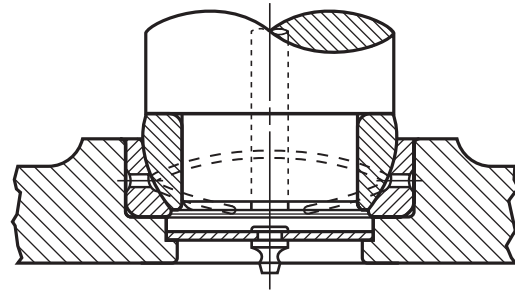

SBT – Relubricatable Mounting

TEMPERATURE

Torrington Spherical Plain bearings without seals will operate satisfactorily up to temperatures of 392°F (200°C). For operation at greater temperatures, special materials and lubricants will be required.

Operating temperatures for sealed bearings should not exceed 212°F (100°C).



TOLERANCES

Pages 348 through 351 list the nominal bearing dimensions. Tolerances for these dimensions are listed in Tables 2 and 3 and are expressed as variances from nominal. Inch-metric conversions are given in these tables for the convenience of the user.

TABLE 2 INNER RING (SF, SBT) BEARINGS

Bore Diameter, d				Single Mean Bore Diam, dmp ⁽¹⁾				Width, B1			
inch		mm		inch		mm		inch		mm	
over	incl.	over	incl.	high	low	high	low	high	low	high	low
0.4375	2.0000	11.112	50.800	+0	-0.0005	+0	-0.013	+0	-0.005	+0	-0.13
2.0000	3.0000	50.800	76.200	+0	-0.0006	+0	-0.015	+0	-0.005	+0	-0.13
3.0000	4.7500	76.200	120.650	+0	-0.0008	+0	-0.020	+0	-0.005	+0	-0.13
4.7500	6.0000	120.650	152.400	+0	-0.0010	+0	-0.025	+0	-0.005	+0	-0.13

⁽¹⁾ "Single Mean Diameter" is defined as the mean diameter in a single radial plane.

TABLE 3 OUTER RING (SF, SBT) BEARINGS

outside Diameter, D				Single Mean Outer Diam, Dmp ⁽¹⁾				Width, B			
inch		mm		inch		mm		inch		mm	
over	incl.	over	incl.	high	low	high	low	high	low	high	low
0.8125	2.0000	20.638	50.800	+0	-0.0005	+0	-0.013	+0	-0.005	+0	-0.13
2.0000	3.1875	50.800	80.962	+0	-0.0006	+0	-0.015	+0	-0.005	+0	-0.13
3.1875	4.7500	80.962	120.650	+0	-0.0008	+0	-0.020	+0	-0.005	+0	-0.13
4.7500	7.0000	120.650	177.800	+0	-0.0010	+0	-0.025	+0	-0.005	+0	-0.13
7.0000	8.7500	177.800	222.250	+0	-0.0012	+0	-0.030	+0	-0.005	+0	-0.13

⁽¹⁾ Tolerances apply before coating SF with MoS₂ and fracturing SF outer ring.
"Single Mean Diameter" is defined as the mean diameter in a single radial plane.

SHAFT FITS

For normal service, the shaft diameters listed in the dimension tables produce recommended fits. Table 4 below is to be used only for applications where a shaft interference fit is required. Consult Torrington for recommendations.

**TABLE – 4 (SF, SBT) BEARINGS,
Shaft Diameter Tolerance for Interference Fit**

Bore Diameter, d				Shaft Tolerance m6			
mm		inch		mm		inch	
over	incl.	over	incl.	high	low	high	low
10	18	0.3937	0.7087	+0.018	+0.007	+0.0007	+0.0003
18	30	0.7087	1.1811	+0.021	+0.008	+0.0008	+0.0003
30	50	1.1811	1.9685	+0.025	+0.009	+0.0010	+0.0004
50	80	1.9685	3.1496	+0.030	+0.011	+0.0012	+0.0005
80	120	3.1496	4.7244	+0.035	+0.013	+0.0014	+0.0005
120	180	4.7244	7.0866	+0.040	+0.015	+0.0016	+0.0006
180	250	7.0866	9.8425	+0.046	+0.017	+0.0018	+0.0007
250	315	9.8425	12.4015	+0.052	+0.020	+0.0020	+0.0008



Radial Bearings Type SF

The type SF Spherical Plain Radial bearing is a unit assembly consisting of a solid, spherical O.D. inner ring and a spherical I.D. outer ring. The outer ring has a single fracture to permit assembly. Both inner and outer rings are phosphate treated and then coated with molybdenum disulphide (MoS₂).

Bearings 7SF12 through 25SF40 are available with reinforced rubber seals. To order, add suffix “-TT” to bearing designation - Example: 25SF40-TT.

Bearings 27SF44 through 60SF96 are available with synthetic resin seals. To order, add suffix “-SS” to bearing designation - Example: 27SF44-SS.

Before ordering any bearing, check for availability.

Inch-metric conversions are given for the convenience of the user. The controlling dimensions are in inches.

For tolerances see Tables 2 and 3. Dimensions listed are after coating with molybdenum disulphide (MoS₂), except outer ring o.d. and internal clearance are before coating and fracturing. The axial internal clearance is approximately 3 times the radial internal clearance.

α is the maximum tilting angle for sealed radial bearings. To utilize the maximum tilting angle α' for unsealed radial bearings, the recommended shaft shoulder diameter d_a , shown in the drawing on the facing page, must not be exceeded. Dimensions and locations of lubrication holes and grooves may be obtained from the Torrington Fafnir Engineering Department.

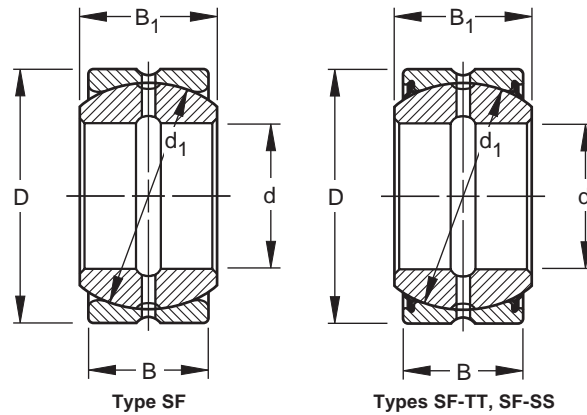

DIMENSIONS – LOAD RATINGS

Bearing Number	Bore d		Outside Diameter D		Inner Ring Width B ₁		Outer Ring Width B		Spherical Diameter d ₁		Radial Clearance* (unmounted)				Radial Limit Load Rating	Dynamic Radial Load Rating
	in.	mm	in.	mm	in.	mm	in.	mm	in.	mm	inches	inches	millimeters	millimeters	lbf	lbf
5SF8	0.5000	12.700	0.8750	22.225	0.437	11.10	0.375	9.52	0.719	18.26	0.004	0.008	0.10	0.20	8330	2690
6SF10	0.6250	15.875	1.0625	26.988	0.547	13.89	0.469	11.91	0.899	22.83	0.004	0.008	0.10	0.20	13000	4200
7SF12	0.7500	19.050	1.2500	31.750	0.656	16.66	0.562	14.27	1.080	27.43	0.005	0.009	0.13	0.23	18700	6070
8SF14	0.8750	22.225	1.4375	36.512	0.765	19.43	0.656	16.66	1.258	31.95	0.005	0.009	0.13	0.23	25500	8250
10SF16	1.0000	25.400	1.6250	41.275	0.875	22.22	0.750	19.05	1.437	36.50	0.005	0.009	0.13	0.23	33300	10800
12SF20	1.2500	31.750	2.0000	50.800	1.093	27.76	0.937	23.80	1.795	45.59	0.005	0.009	0.13	0.23	52000	16800
13SF22	1.3750	34.925	2.1875	55.562	1.187	30.15	1.031	26.19	1.937	49.20	0.005	0.009	0.13	0.23	61300	20100
15SF24	1.5000	38.100	2.4375	61.912	1.312	33.32	1.125	28.58	2.155	54.74	0.005	0.009	0.13	0.23	75000	24300
17SF28	1.7500	44.450	2.8125	71.438	1.531	38.89	1.312	33.32	2.515	63.88	0.005	0.009	0.13	0.23	102000	33000
20SF32	2.0000	50.800	3.1875	80.962	1.750	44.45	1.500	38.10	2.875	73.02	0.005	0.009	0.13	0.23	133000	43200
22SF36	2.2500	57.150	3.5625	90.488	1.969	50.01	1.687	42.85	3.235	82.17	0.006	0.010	0.15	0.25	169000	54600
25SF40	2.5000	63.500	3.9375	100.012	2.187	55.55	1.875	47.62	3.590	91.19	0.006	0.010	0.15	0.25	208000	67400
27SF44	2.7500	69.850	4.3750	111.125	2.406	61.11	2.062	52.37	3.950	100.33	0.006	0.010	0.15	0.25	252000	81600
30SF48	3.0000	76.200	4.7500	120.650	2.625	66.68	2.250	57.15	4.312	109.52	0.006	0.010	0.15	0.25	300000	97100
32SF52	3.2500	82.550	5.1250	130.175	2.844	72.24	2.437	61.90	4.675	118.74	0.007	0.011	0.18	0.28	353000	114000
35SF56	3.5000	88.900	5.5000	139.700	3.062	77.77	2.625	66.68	5.040	128.02	0.007	0.011	0.18	0.28	410000	132000
37SF60	3.7500	95.250	5.8750	149.225	3.281	83.34	2.812	71.42	5.390	136.91	0.007	0.011	0.18	0.28	467000	152000
40SF64	4.0000	101.600	6.2500	158.750	3.500	88.90	3.000	76.20	5.750	146.05	0.007	0.011	0.18	0.28	533000	173000
45SBB72	4.5000	114.300	7.0000	177.800	3.937	100.00	3.375	85.72	6.475	164.46	0.007	0.011	0.18	0.28	673000	218000
50SBB80	5.0000	127.000	7.7500	196.850	4.375	111.13	3.750	95.25	7.190	182.63	0.007	0.011	0.18	0.28	833000	270000
60SBB96	6.0000	152.400	8.7500	222.250	4.750	120.65	4.125	104.78	8.156	207.16	0.007	0.011	0.18	0.28	1050000	351000

*Prior to coating with MoS₂ and fracturing outer ring.



MOUNTING

The housing bore dimensions listed below are applicable to bearings mounted in steel.

Due to fracturing, the outer ring may be slightly out-of-round. However, roundness will be restored when the bearing is mounted in a housing of sufficient cross-section.

The preferred shaft and housing bore dimensions are listed below. To obtain a shaft interference fit, refer to the m6 tolerance limits listed in table 4.

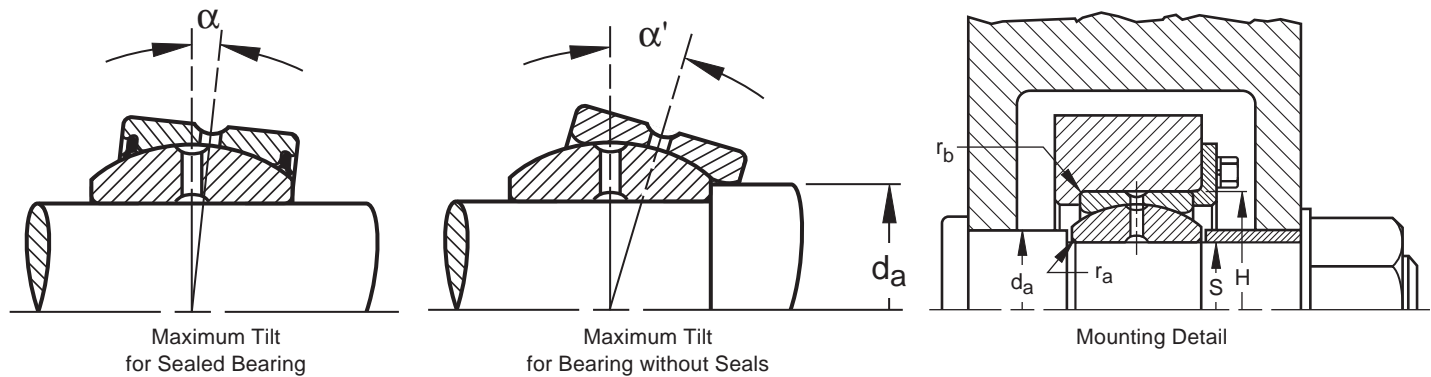

MOUNTING DIMENSIONS

Weight (approx.)	Tilting Angle		Shaft Shoulder Diameter d_a		Shaft Fillet Radius* r_a^\dagger (max)		Housing Fillet Radius r_b^\ddagger (max)		Shaft Diameter S				Housing Bore H				
	a	a ϕ	in.	mm	in.	mm	in.	mm	inches		millimeters		inches		millimeters		
	deg.	deg.							max.	min.	max.	min.	min.	max.	min.	max.	
0.044	0.020	5.5	14	0.56	14.3	*	*	0.022	0.6	0.4998	0.4994	12.695	12.685	0.8739	0.8747	22.197	22.217
0.079	0.036	6	14	0.70	17.8	*	*	0.032	0.8	0.6248	0.6244	15.870	15.860	1.0614	1.0622	26.960	26.980
0.126	0.057	6	14.5	0.84	21.4	*	*	0.032	0.8	0.7497	0.7492	19.042	19.029	1.2487	1.2497	31.717	31.742
0.193	0.087	6	14.5	0.98	25.0	*	*	0.032	0.8	0.8747	0.8742	22.217	22.204	1.4362	1.4372	36.479	36.504
0.276	0.125	6	14.5	1.12	28.6	*	*	0.032	0.8	0.9997	0.9992	25.392	25.379	1.6237	1.6247	41.242	41.267
0.516	0.234	6	14.5	1.41	35.7	*	*	0.032	0.8	1.2496	1.2490	31.740	31.725	1.9985	1.9997	50.762	50.792
0.770	0.349	5.5	14	1.53	38.9	*	*	0.032	0.8	1.3746	1.3740	34.915	34.900	2.1860	2.1872	55.524	55.554
0.934	0.424	6	14.5	1.70	43.3	*	*	0.032	0.8	1.4996	1.4990	38.090	38.075	2.4360	2.4372	61.874	61.904
1.430	0.649	6	15.5	1.97	50.0	*	*	0.032	0.8	1.7496	1.7490	44.440	44.425	2.8110	2.8122	71.399	71.429
2.070	0.939	6	15.5	2.25	57.2	*	*	0.032	0.8	1.9996	1.9989	50.790	50.772	3.1856	3.1870	80.914	80.950
2.920	1.324	6	14	2.56	65.1	*	*	0.032	0.8	2.2496	2.2489	57.140	57.122	3.5606	3.5620	90.439	90.475
4.090	1.855	6	14	2.84	72.2	*	*	0.032	0.8	2.4996	2.4989	63.490	63.472	3.9356	3.9370	99.964	100.000
5.380	2.440	6	12	3.12	79.4	0.022	0.6	0.032	0.8	2.7496	2.7489	69.840	69.822	4.3731	4.3745	111.077	111.113
6.870	3.116	6	12	3.41	86.5	0.022	0.6	0.032	0.8	2.9996	2.9989	76.190	76.172	4.7478	4.7494	120.594	120.635
8.630	3.914	6	12	3.70	94.1	0.022	0.6	0.032	0.8	3.2495	3.2486	82.537	82.514	5.1228	5.1244	130.119	130.160
10.700	4.853	6	12	3.97	101.0	0.022	0.6	0.032	0.8	3.4995	3.4986	88.887	88.864	5.4978	5.4994	139.644	139.685
13.000	5.897	6	12	4.25	108.0	0.022	0.6	0.032	0.8	3.7495	3.7486	95.237	95.214	5.8728	5.8744	149.169	149.210
15.600	7.076	6	11.5	4.56	116.0	0.022	0.6	0.032	0.8	3.9995	3.9986	101.587	101.564	6.2478	6.2494	158.694	158.735
21.900	9.934	6	12	5.12	130.0	0.032	0.8	0.044	1.1	4.4995	4.4986	114.287	114.264	6.9978	6.9994	177.744	177.785
29.700	13.472	6	12	5.69	144.0	0.032	0.8	0.044	1.1	4.9994	4.9984	126.985	126.960	7.7474	7.7492	196.784	196.830
38.800	17.600	5	10.5	6.59	168.0	0.032	0.8	0.044	1.1	5.9994	5.9984	152.385	152.360	8.7474	8.7492	222.184	222.230

*For bearing sizes 5SF8 through 25SF40, shaft and shoulder should be undercut to eliminate fillet.

†Equal to minimum inner ring bore chamfer.

‡Equal to minimum outer ring o.d. chamfer.



Angular Contact Bearings Type SBT

The type SBT Spherical Plain Angular Contact bearing is a separable assembly consisting of an inner and outer ring having hemispherically shaped surfaces which mate with each other. Both inner and outer rings are phosphate treated and then coated with molybdenum disulphide (MoS₂).

If a Torrington ring is to be assembled with a ring of another make, consult the Torrington engineering department. If it is necessary to order inner and outer rings separately, specify by adding suffix “-OR” for outer ring or “-IR” for inner ring.

Before ordering any bearing, check for availability.

Inch-metric conversions are given for the convenience of the user. The controlling dimensions are in inches.

For tolerances see Tables 2 and 3. Dimensions listed are after coating with molybdenum disulphide (MoS₂).

α is the maximum tilting angle through the shaft. A stub shaft can be used to obtain a larger angle.

Dimensions and locations of lubrication holes and grooves may be obtained from the Torrington Fafnir Engineering Department.

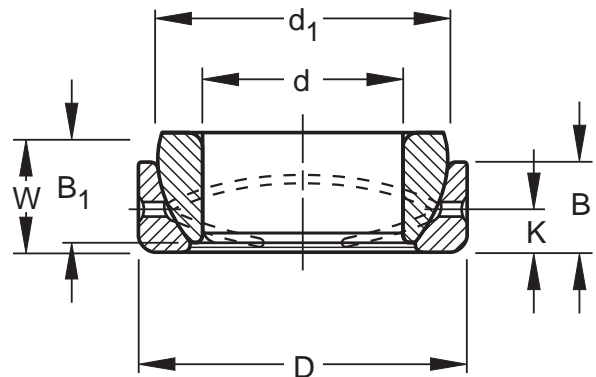

DIMENSIONS – LOAD RATINGS

Bearing Number	Bore d		Outside Diameter D		Inner Ring Width B ₁		Outer Ring Width B		Total Width W		Lube Hole Location K		Spherical Diameter d ₁		Load Ratings	
	in.	mm	in.	mm	in.	mm	in.	mm	in.	mm	in.	mm	in.	mm	Thrust Limit Load Rating	Dynamic Thrust Load Rating
5SBT8	0.5000	12.700	0.8750	22.225	0.270	6.86	0.190	4.83	0.300	7.62	0.094	2.39	0.719	18.26	4600	1860
6SBT10	0.6250	15.875	1.0625	26.988	0.340	8.64	0.250	6.35	0.370	9.40	0.109	2.77	0.899	22.83	7600	3080
7SBT12	0.7500	19.050	1.2500	31.750	0.410	10.41	0.310	7.87	0.440	11.18	0.125	3.18	1.080	27.43	11100	4500
8SBT14	0.8750	22.225	1.4375	36.512	0.480	12.19	0.380	9.65	0.520	13.21	0.172	4.37	1.258	31.95	15400	6210
10SBT16	1.0000	25.400	1.6250	41.275	0.550	13.97	0.440	11.18	0.600	15.24	0.203	5.16	1.437	36.50	19400	7860
12SBT20	1.2500	31.750	2.0000	50.800	0.700	17.78	0.550	13.97	0.740	18.80	0.234	5.94	1.795	45.59	31000	12500
13SBT22	1.3750	34.925	2.1875	55.562	0.770	19.56	0.600	15.24	0.840	21.34	0.281	7.14	1.937	49.20	37000	15100
15SBT24	1.5000	38.100	2.4375	61.912	0.840	21.34	0.660	16.76	0.910	23.11	0.312	7.92	2.155	54.74	44500	18300
17SBT28	1.7500	44.450	2.8125	71.438	0.980	24.89	0.790	20.07	1.070	27.18	0.328	8.33	2.515	63.88	60000	24400
20SBT32	2.0000	50.800	3.1875	80.962	1.130	28.70	0.920	23.37	1.230	31.24	0.375	9.52	2.875	73.02	79000	32300
22SBT36	2.2500	57.150	3.5625	90.488	1.270	32.26	1.050	26.67	1.390	35.31	0.453	11.51	3.235	82.17	100000	40800
25SBT40	2.5000	63.500	3.9375	100.012	1.420	36.07	1.180	29.97	1.540	39.12	0.500	12.70	3.590	91.19	126000	51500
27SBT44	2.7500	69.850	4.3750	111.125	1.560	39.62	1.275	32.38	1.700	43.18	0.515	13.08	3.950	100.33	154000	62150
30SBT48	3.0000	76.200	4.7500	120.650	1.710	43.43	1.405	35.69	1.860	47.24	0.578	14.68	4.312	109.52	186000	75000
32SBT52	3.2500	82.550	5.1250	130.175	1.860	47.24	1.545	39.24	2.030	51.56	0.656	16.66	4.675	118.74	218000	87500
35SBT56	3.5000	88.900	5.5000	139.700	2.000	50.80	1.675	42.54	2.180	55.37	0.703	17.86	5.040	128.02	257000	102400
37SBT60	3.7500	95.250	5.8750	149.225	2.150	54.61	1.805	45.85	2.340	59.44	0.765	19.43	5.390	136.91	295000	118500
40SBT64	4.0000	101.600	6.2500	158.750	2.300	58.42	1.935	49.15	2.500	63.50	0.781	19.84	5.750	146.05	336000	135000
45SBT72	4.5000	114.300	7.0000	177.800	2.590	65.79	2.195	55.75	2.800	71.12	0.875	22.22	6.475	164.46	432000	173500
50SBT80	5.0000	127.000	7.7500	196.850	2.880	73.15	2.455	62.36	3.130	79.50	1.000	25.40	7.190	182.63	524000	211000
60SBT96	6.0000	152.400	8.7500	222.250	3.100	78.74	2.615	66.42	3.375	85.72	1.370	34.80	8.156	207.16	585000	235000



MOUNTING

The housing bore dimensions listed below are applicable to bearings mounted in steel. The recommended diameters of shoulder supports should be used to assure proper function of the bearing.

The preferred shaft and housing bore dimensions are listed below. To obtain a shaft interference fit, refer to the m6 tolerance limits listed in table 4.

The bearings are to be mounted with sufficient axial preload to ensure contact of the spherical surfaces under all load conditions.

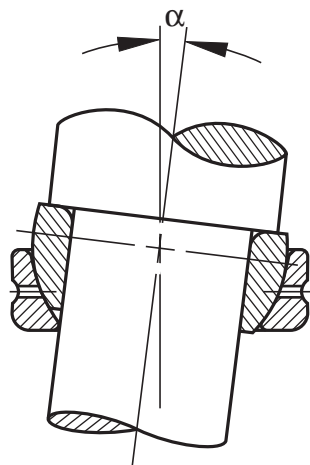

Maximum Tilt for Bearing

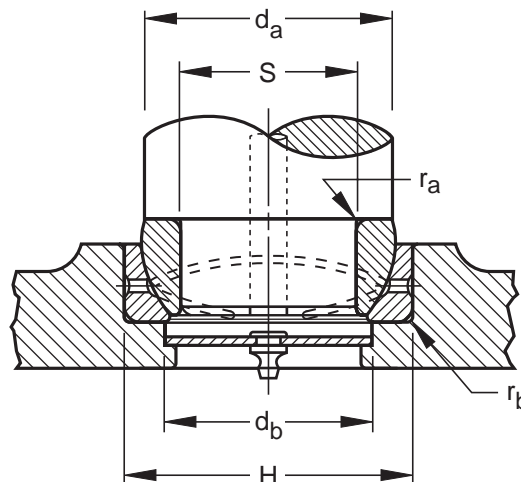

Mounting Detail

MOUNTING DIMENSIONS

Weight		Tilting Angle α	Shaft Shoulder Diameter d_a		Shaft Fillet Radius r_a^\dagger		Housing Shoulder Diameter d_b		Housing Fillet Radius r_b		Shaft Diameter S				Housing Bore H			
(approx.)			(max)			(max)				(max)		inches		millimeters		inches		millimeters
lbs	kg	deg.	in.	mm	in.	mm	in.	mm	in.	mm	max.	min.	max.	min.	min.	max.	min.	max.
0.029	0.013	7	0.67	17.0	0.020	0.5	0.57	14.5	0.020	0.5	0.4998	0.4994	12.695	12.685	0.8739	0.8747	22.197	22.217
0.056	0.025	6	0.84	21.3	0.030	0.8	0.70	17.8	0.030	0.8	0.6248	0.6244	15.870	15.860	1.0614	1.0622	26.960	26.980
0.083	0.038	6	1.02	25.9	0.040	1.0	0.84	21.3	0.040	1.0	0.7497	0.7492	19.042	19.029	1.2487	1.2497	31.717	31.742
0.110	0.050	5.5	1.23	31.2	0.080	2.0	0.97	24.6	0.080	2.0	0.8747	0.8742	22.217	22.204	1.4362	1.4372	36.479	36.504
0.188	0.085	6	1.40	35.6	0.080	2.0	1.12	28.4	0.080	2.0	0.9997	0.9992	25.392	25.379	1.6237	1.6247	41.242	41.267
0.351	0.159	6	1.71	43.4	0.080	2.0	1.39	35.3	0.080	2.0	1.2496	1.2490	31.740	31.725	1.9985	1.9997	50.762	50.792
0.470	0.213	4	1.89	48.0	0.100	2.5	1.48	37.6	0.100	2.5	1.3746	1.3740	34.915	34.900	2.1860	2.1872	55.524	55.554
0.662	0.300	5.5	2.05	52.1	0.100	2.5	1.66	42.2	0.100	2.5	1.4996	1.4990	38.090	38.075	2.4360	2.4372	61.874	61.904
1.010	0.458	6	2.36	59.9	0.100	2.5	1.95	49.5	0.100	2.5	1.7496	1.7490	44.440	44.425	2.8110	2.8122	71.399	71.429
1.480	0.671	5.5	2.75	69.8	0.140	3.6	2.22	56.4	0.140	3.6	1.9996	1.9989	50.790	50.772	3.1856	3.1870	80.914	80.950
2.090	0.948	5.5	3.06	77.7	0.140	3.6	2.50	63.5	0.140	3.6	2.2496	2.2489	57.140	57.122	3.5606	3.5620	90.439	90.475
2.490	1.129	5	3.37	85.6	0.140	3.6	2.75	69.9	0.140	3.6	2.4996	2.4989	63.490	63.472	3.9356	3.9370	99.964	100.000
3.860	1.751	5	3.71	94.2	0.180	4.6	3.03	77.0	0.180	4.6	2.7496	2.7489	69.840	69.822	4.3731	4.3745	111.077	111.113
5.020	2.277	5	4.07	103.0	0.180	4.6	3.30	83.8	0.180	4.6	2.9996	2.9989	76.190	76.172	4.7478	4.7494	120.594	120.635
6.360	2.885	5	4.42	112.0	0.180	4.6	3.58	90.9	0.180	4.6	3.2495	3.2486	82.537	82.514	5.1228	5.1244	130.119	130.160
7.870	3.570	5	4.77	121.0	0.180	4.6	3.85	97.8	0.180	4.6	3.4995	3.4986	88.887	88.864	5.4978	5.4994	139.644	139.685
9.590	4.350	4.5	5.11	130.0	0.180	4.6	4.10	104.0	0.180	4.6	3.7495	3.7486	95.237	95.214	5.8728	5.8744	149.169	149.210
11.600	5.262	4.5	5.43	138.0	0.180	4.6	4.37	111.0	0.180	4.6	3.9995	3.9986	101.587	101.564	6.2478	6.2494	158.694	158.735
17.100	7.756	4.5	6.14	156.0	0.180	4.6	4.90	125.0	0.180	4.6	4.4995	4.4986	114.287	114.264	6.9978	6.9994	177.744	177.785
24.400	11.068	4.5	6.83	174.0	0.180	4.6	5.47	139.0	0.180	4.6	4.9994	4.9984	126.984	126.959	7.7474	7.7492	196.784	196.830
38.300	17.373	4.5	7.75	197.0	0.180	4.6	6.50	165.0	0.180	4.6	5.9994	5.9984	152.385	152.360	8.7474	8.7492	222.184	222.230

† Equal to minimum inner ring bore chamfer.

‡ Equal to minimum outer ring o.d. chamfer.