

SCHNEEBERGER
LINEAR TECHNOLOGY

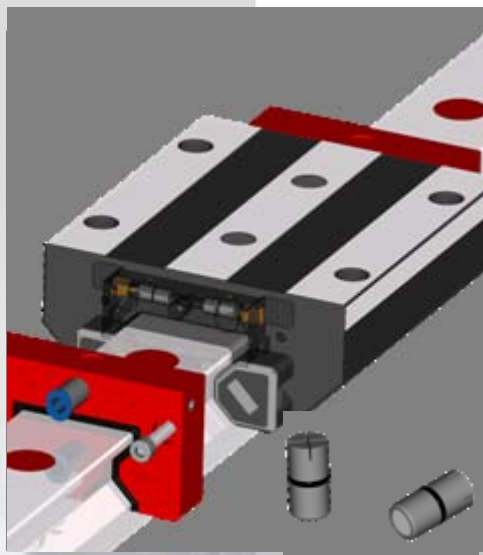

MONORAIL
Compressed-air powered
minimum volume lubrication

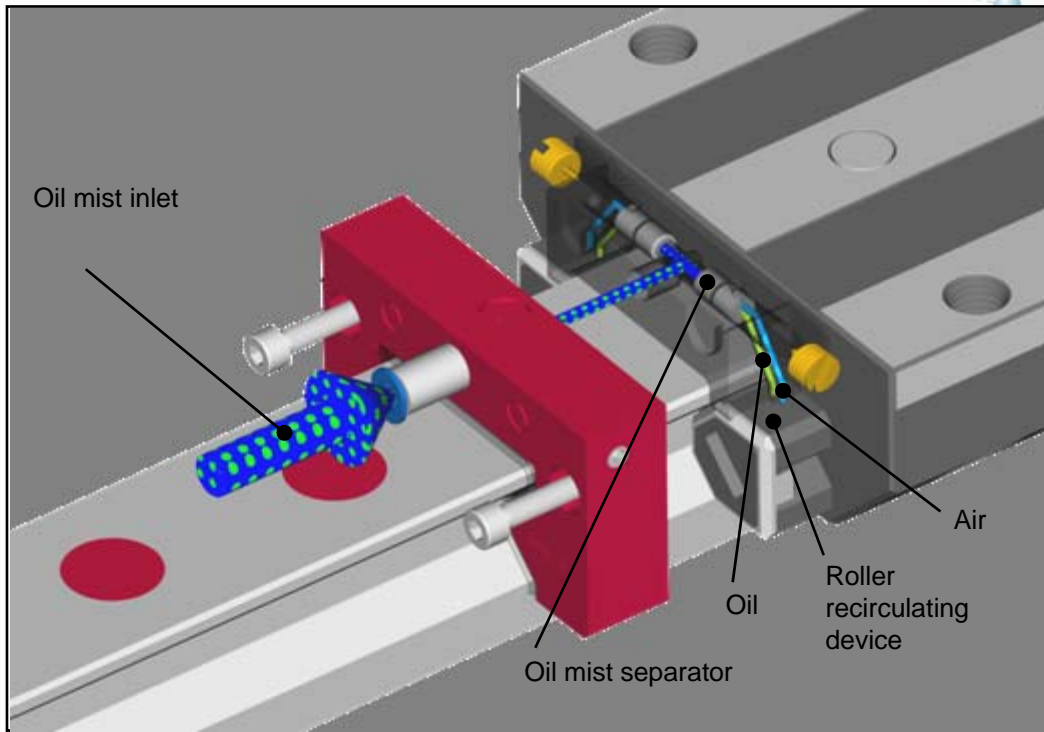

The use of patented separators in the ELHA system in SCHNEEBERGER's linear guides permits the almost 100% separation of the lubricating oil from the oil mist provided. This provides perfectly metered and permanent lubrication as well as the environmentally compatible ejection of the air barrier.

Technical specifications for a machine for the complete machining of a console for the automotive industry

5-station rotary index machining center consisting of:	
4 off, 3-axis units each with 22 lubrication points for roller guides and ball screw drive incl. bearings	
Total of 88 lubricating points on 12 axes	
2 multispindle heads with 13 spindles, size HSK 40 - HSK 63	
Total oil consumption of Voltol 46:	0.222 dm ³ /24 h
Total air consumption	105 m ³ /h
Individual figures:	
Oil consumption per lubrication point for roller guide and ball screw drive incl. bearings	0.079 cm ³ /h
Air consumption per lubrication point for roller guide and ball screw drive incl. bearings	0.900 m ³ /h
Oil consumption per spindle	0.176 cm ³ /h
Air consumption per spindle	2.0 m ³ /h



Design:

Oil particles are created in an atomizer. With the help of a stream of air, these atomized particles are introduced to the oil-line network. Mixed with oil, this air is fed to the individual lubricating points via systems of lines and distributors. The flow of air is reduced in separators located ahead of the individual lubricating points, thereby separating the oil from the air and feeding it to the lubricating points. The compressed air escapes via the carriage and has the function of an air barrier.

Typical applications:

- Machine tools operating exceptionally contaminated environments
- Woodworking machinery
- Machine tools with fine dust particles, such as dry machining for example
- Modern machine tools with existing oil-mist lubrication of spindle units, fly cutters and other machine elements

Benefits:

- The ingress of liquids and particles of dirt is prevented by the sluicing effect
- Controllable and known operating conditions ensure a stable and foreseeable service life
- Consistent distribution of the lubricant to the rollers permits safe short-stroke operation
- Provision of lubrication independent of location based on the active supply of lubricant directly to the roller elements
- Lower costs thanks to less complicated oil pipes and a reduction in installation work
- Low maintenance costs thanks to metered lubricant consumption

The use of a low-outlay, ELHA oil mist lubrication system for linear guides ensures that guides will have a long service life even under conditions involving serious contamination. It also makes sense to integrate linear guides in the existing lubrication system since oil-mist lubrication is gaining rapidly in importance in other elements of modern machine tools.

Carriage size	MR 35, MR 45, MR 55, MR 65, MR 100
No. of ELHA system separating elements per carriage	2 or 4
Air consumption per carriage size 45*	Approx. 15 dm ³ /min. with 2 separators
Oil consumption per carriage*	< 0.1 cm ³ /h
Air shield pressure	1.0 bar
Oil type	Voltol 46 lubricating oil

*Values given apply to permanent lubrication



Layout for a complete oil-mist lubrication system:



INNOVATION

The Machine Tool Lubrication of the Future
 One System for all Lubrication Points
 Improved Lifetime
 Minimal Oil Quantities at exactly the Right Locations

Long transports of the lubrication medium without reduction of the function!

Simple and cost-effective tubing installation!

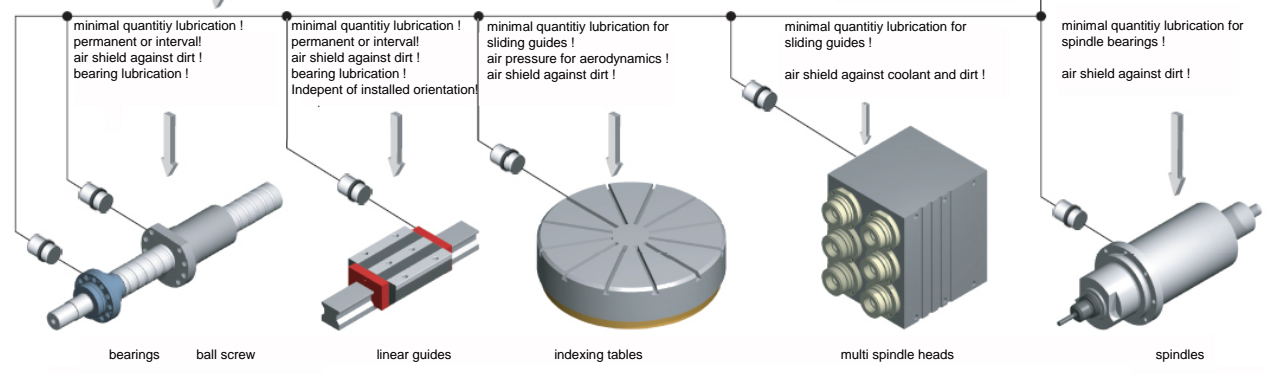
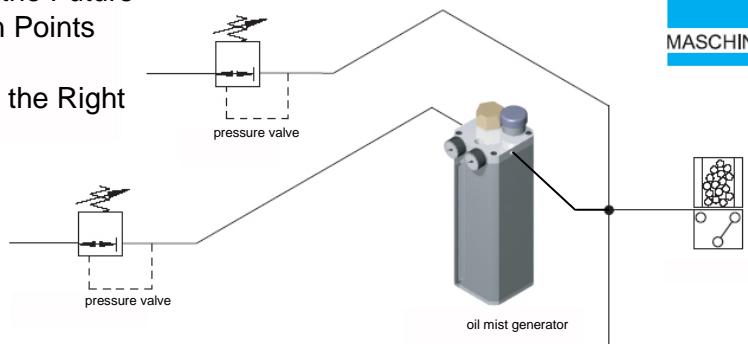

Patent pending for system and system elements!

© ELHA Maschinenbau

www.schneeberger.com