

SCHNEEBERGER

LINEAR TECHNOLOGY



Slides
NE - AL

Positioning Tables
NFM
NH2 - AL



> Slides NE 1, 2, 3 - AL

Type NE AL slides are designed as closed model, which means that they can be sealed on all sides with small spacing between upper and lower sections. Prevent the ingress of dirt. All sizes are equipped with linear guide type R bearings. There are standardized attaching thread holes in the upper and lower section. Table parts in aluminium. Linear guideways in corrosion resistant steel. Tables can be integrated in any position.

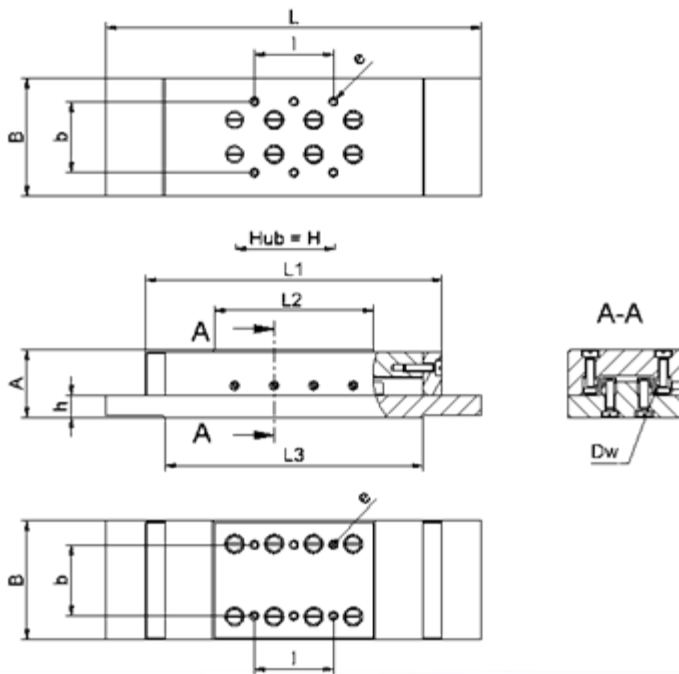

Type NE	A	B	H	Dw	L	L1	L2	L3	e	l	b	h	C (n N)	MI (in Nm)	Mq (in Nm)	Weight (in gr)
NE 1 - 45 - AL	17	30	10	1.5	55	45	20	45	M2x5	1x17	18	5.5	250	1.2	1.6	70
NE 1 - 60 - AL			15		75	60	30	55		1x10			350	1.86	2.3	90
NE 1 - 75 - AL			20		95	75	40	65		2x10			500	2.7	3.3	120
NE 2 - 60 - AL	21	40	15	2	75	60	30	59	M3x6	1x25	25	6.5	425	2.7	3.8	150
NE 2 - 85 - AL			25		110	85	45	74		1x15			680	4.7	6.1	220
NE 2 - 115 - AL			40		155	115	60	89		2x15			850	6.1	7.6	300
NE 3 - 100 - AL	28	60	30	3	130	100	50	84	M4x8	1x40	39	9	910	7.8	12.7	460
NE 3 - 140 - AL			45		185	140	75	109		1x25			1300	11.7	18.2	700
NE 3 - 180 - AL			60		240	180	100	134		2x25			1820	16.9	25.4	930

> NFM 7 / 9 / 12

Single axis manual driven stages with SCHNEEBERGER MINIRAIL – guideways. Manual positioning by a precision lead-screw, with anti-backlash nut and graduated drum, that can be set to zero position. Reading accuracy 0.01mm, strokes from 25mm to 150mm. NFM is a modular system with options for table base and top plate lengths, to give strokes between 25 and 150mm. Table parts made in aluminium anodised, MINIRAIL linear guideways and lead screw in corrosion resistant steel. Stage can be integrated in any plane. Special sizes and/or special attaching holes available on request. Optional clamping device on the side or directly on the lead screw (L dimension increased by 7mm). The clamping device can be mounted on either side of the stage (Size 7 without hand crank).

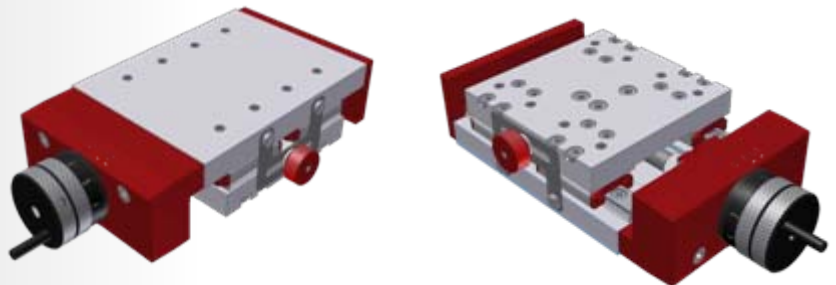

Options

clamping left/right

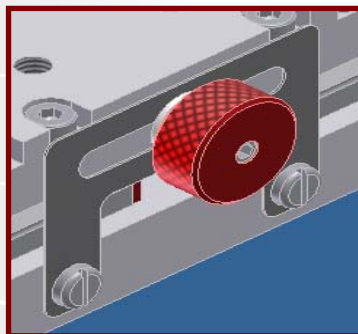

clamping on lead screw

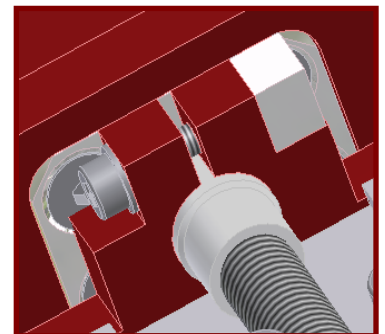

Type NFM	A	B	H	Dw	L	L1	l	l1	e1	e2
----------	---	---	---	----	---	----	---	----	----	----

NFM 7- 75/50	25	50	25	MNN 7	75	50	3x15	2x15	M4/8	M4x8
NFM 7-100/50			50		100	50	5x15	2x15		
NFM 7-125/50			75		125	50	3x30	2x15		
NFM 7-100/75			25		100	75	5x15	4x15		
NFM 7-125/75			50		125	75	3x30	4x15		
NFM 7-150/75			75		150	75	4x30	4x15		

NFM 9-100/75	32	75	25	MNN 9	100	75	3x20	3x20	M5x11	M5x11
NFM 9-125/75			50		125	75	4x20	3x20		
NFM 9-150/75			75		150	75	5x20	3x20		
NFM 9-175/75			100		175	75	7x20	3x20		
NFM 9-200/75			125		200	75	8x20	3x20		
NFM 9-125/100			25		125	100	4x20	4x20		
NFM 9-150/100			50		150	100	5x20	4x20		
NFM 9-175/100			75		175	100	7x20	4x20		
NFM 9-200/100			100		200	100	8x20	4x20		

NFM 12-150/100	36	100	50	MNN 12	150	100	4x25	3x25	M5x11	M5x11
NFM 12-200/100			100		200	100	6x25	3x25		
NFM 12-250/100			150		250	100	4x50	3x25		

Type NFM	b	b1	c1	c2	c3	c4	ø1	øy	x	z
----------	---	----	----	----	----	----	----	----	---	---

NFM 7- 75/50	30	30	5	14	19.5	"	ø24	ø10.3	6.1	7.5
NFM 7-100/50										
NFM 7-125/50										
NFM 7-100/75										
NFM 7-125/75										
NFM 7-150/75										

NFM 9-100/75	52	52	6	19	21.5	15	ø30	ø15.3	8.2	9.8
NFM 9-125/75										
NFM 9-150/75										
NFM 9-175/75										
NFM 9-200/75										
NFM 9-125/100										
NFM 9-150/100										
NFM 9-175/100										
NFM 9-200/100										

NFM 12-150/100	75	75	7	19	21.5	15	ø34	ø15.3	8.7	9.8
NFM 12-200/100										
NFM 12-250/100										

Type NFM	C (n N)	MI (Nm)	Mq (Nm)	Weight (~kg)	ø+P (mm)
----------	---------	---------	---------	--------------	----------

NFM 7- 75/50	2960	37	47	0.4	M5x0.5
NFM 7-100/50				0.5	
NFM 7-125/50				0.6	
NFM 7-100/75		0.7			
NFM 7-125/75		0.8			
NFM 7-150/75		0.9			

NFM 9-100/75	5408	113	146	0.8	M8x1
NFM 9-125/75				0.9	
NFM 9-150/75				1	
NFM 9-175/75				1.1	
NFM 9-200/75				1.2	
NFM 9-125/100				1	
NFM 9-150/100		1.1			
NFM 9-175/100		1.2			
NFM 9-200/100		1.3			

NFM 12-150/100	8032	245	285	1.7	M8x1
NFM 12-200/100				1.9	
NFM 12-250/100				2.1	

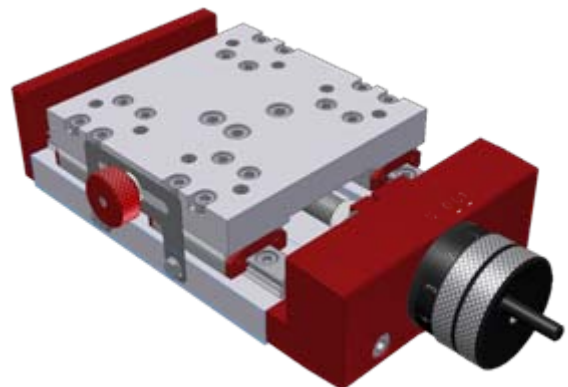

Type NFM 7 / 9 / 12

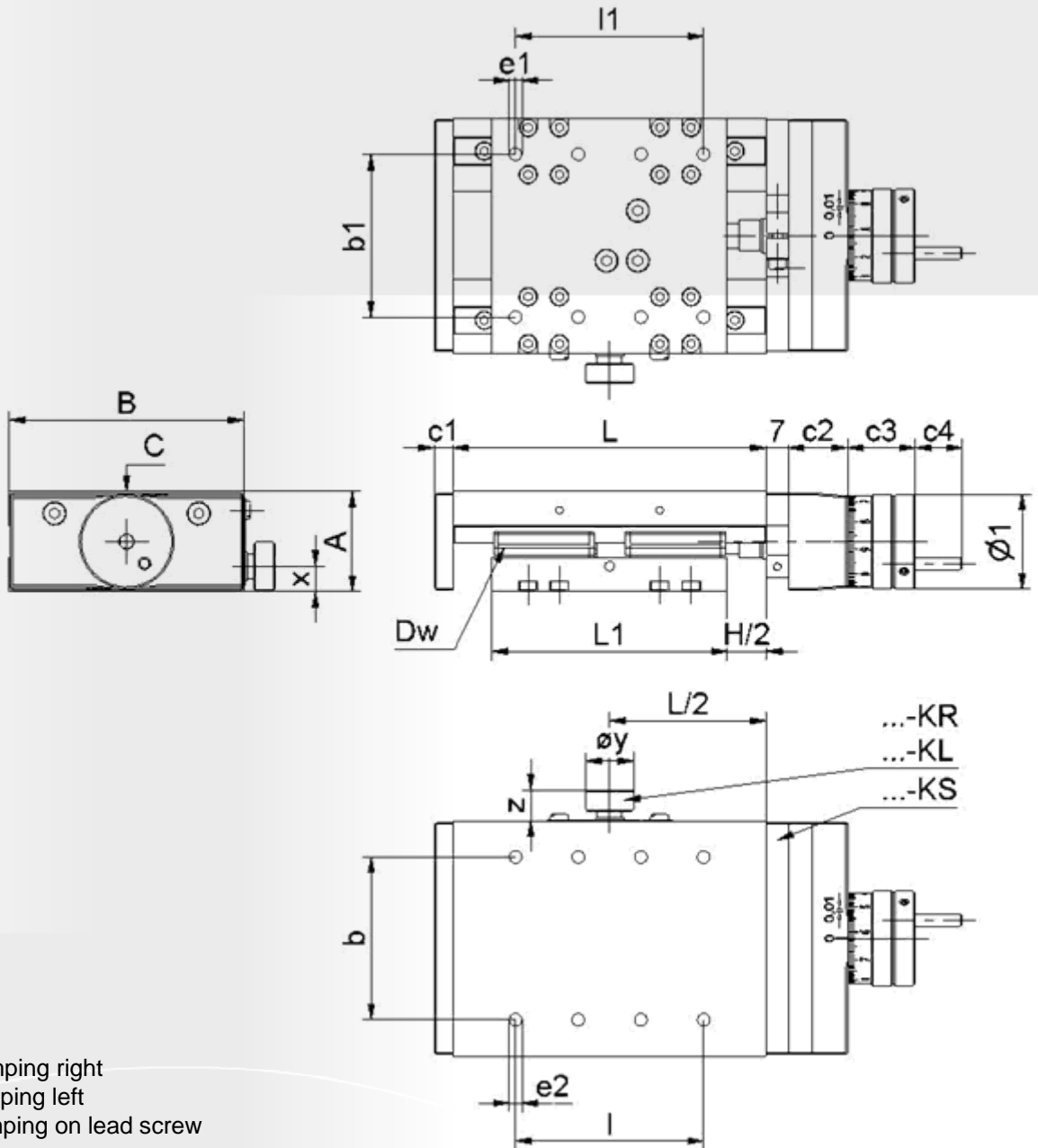

> Positioning Tables NH2-40-40-AL, NH2-65-65-AL, NH2-110-110-AL

Single axis stages with SCHNEEBERGER linear guideways Type R2-RF. Manual positioning with micrometer, reading accuracy 0.01mm. Table parts are lightly loaded onto the micrometer screw by a tension spring. Design is available with or without micrometer. Micrometer fastening on the side or front of the stage. Tables of the same size can easily be assembled into 2 axis configuration. Standard strokes 13/13 and 25/(40)mm. Special hole patterns or strokes on request. All designs with a clamping system on the side of the stage. Table parts in aluminium anodised. Linear guideways in corrosion resistant steel. Tables can be integrated in any plane (micrometer below stage in vertical orientation!).



Type NH	A	B	H	H1	Dw	L	I1	I2	I3	I4	I5	I6	F	F1	b1	b2	h	h1	e1	e2	e3	e4	u	v	x	y	z	z1
NH2-40-40-AL	19	40	± 6.5	± 6.5	R2	40			4	32	37.5	37.5	39.5	21.5	4	32	6	2.5	3.5	6	M3	6	11	10	13	10.3	7.5	20
NH2-65-65-AL	20	65	± 6.5	± 6.5	R2	65	17.5	2x15	3.5	58	37.5	9.75	37.3	21.5	3.5	58	6.5	3	3.5	6	M3	6	13	12	13	10.3	7.5	32.5
NH2-110-110-AL	25	110	± 20	± 12.5	R2	110	25	2x30	6	98	80.4	16.4	46	40	6	98	8	3.5	4.5	7.5	M4	8	15	13	16	15.3	9.8	55

Type NH	C in N	ML Nm	MQ Nm	Weight kg
NH2-40-40-AL	425	2.7	3.9	0.2
NH2-65-65-AL	850	7.5	13.5	0.4
NH2-110-110-AL	1420	12.9	43.5	1.7

Positioning Tables

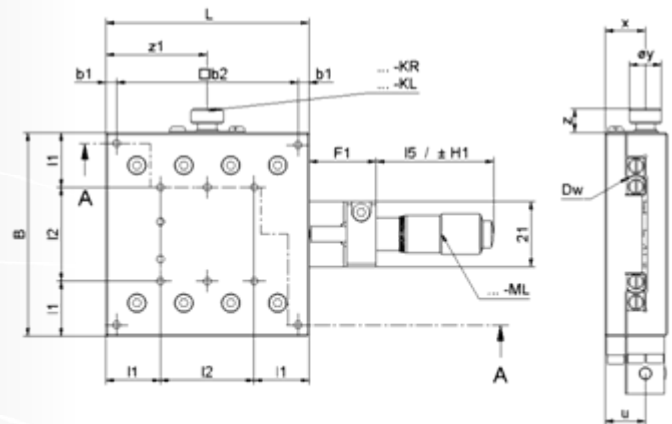
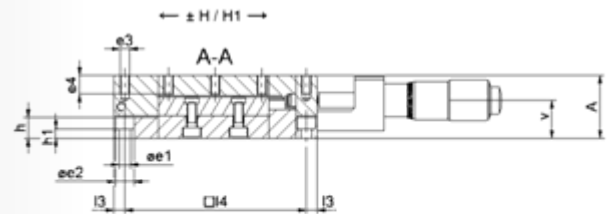
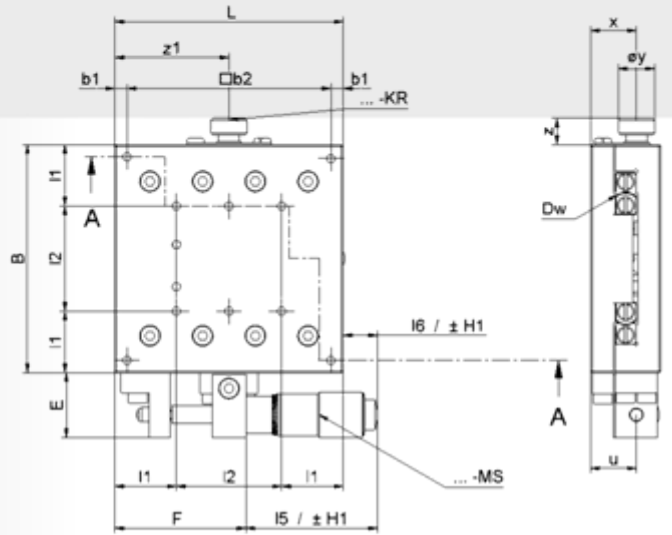
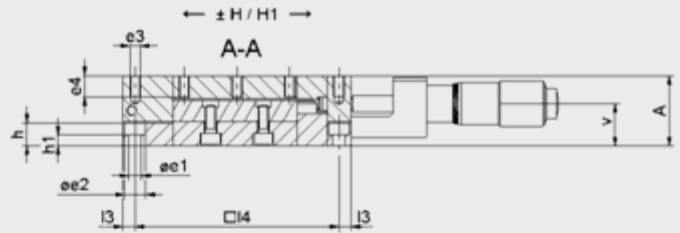

Options

- MS Micrometer side
- ML Micrometer front
- KR clamping right
- KL clamping left



SCHNEEBERGER – «Essentials for the Best!»

CATALOGUES

MONORAIL and AMS
LINEAR BEARINGS and Recirculating units
SLIDES
MINIRAIL
AUTOMATION



BROCHURES

MINIMODULE
SYSTEMS
SCHNEEBERGER Mineral casting
SPECIAL COMPONENTS



SCHNEEBERGER COMPANIES

SWITZERLAND

SCHNEEBERGER AG
St. Urbanstrasse 12
4914 Roggwil/BE
Phone +41 62 918 41 11
Fax +41 62 918 41 00

E-Mail:
info-ch@schneeburger.com
www.schneeburger.com

GERMANY

SCHNEEBERGER GmbH
Gräfenau
75339 Höfen/Enz
Phone +49 7081 782 0
Fax +49 7081 782 124

E-Mail:
info-d@schneeburger.com

ITALY

SCHNEEBERGER S.r.l.
Piazza Aldo Moro, 2
21018-Sesto Calende
Phone +39 0331 93 2010
Fax +39 0331 93 1655

E-Mail:
info-i@schneeburger.com

USA

SCHNEEBERGER Inc.
11 DeAngelo Drive
Bedford, MA 01730
Phone +1 781 271 0140
Fax +1 781 275 4749

E-Mail:
info-usa@schneeburger.com

CZECH REPUBLIC

SCHNEEBERGER Mineralgusstechnik s.r.o.
Prumyslový park 32/20
350 02 Cheb – Dolní Dvory
Phone +420 354 400 941
Fax +420 354 400 940

E-Mail:
info-mineralguss@schneeburger.com

CHINA

SCHNEEBERGER (Shanghai) Co., Ltd.
Rm 405, Victoria Businessbuilding C,
No.96 Ronghua Rd.(E.) Gubei New Area
201103 Shanghai
Phone +86 21 6209 0037 / 27
Fax +86 21 6208 5488

E-Mail:
info-cn@schneeburger.com

JAPAN

Nippon SCHNEEBERGER KK
1-49-12 Shimouma, Setagaya-ku
Tokyo 154-0002
Phone +81 3 5779 7339
Fax +81 3 3487 6010

E-Mail:
info-j@schneeburger.com

INDIA

SCHNEEBERGER India Private Limited.
DHANNUR, 2nd FLOOR, 15, SIR P.M ROAD, FORT
MUMBAI. 400 001
Phone +91 22 2263 2372
Fax +91 22 2263 2371

E-Mail:
info-in@schneeburger.com

SCHNEEBERGER SELLING AGENCIES

AUSTRIA

Phone +43 2 2387 2945
Fax +43 2 2387 2983
Mobil +43 67 6935 1035

E-Mail:
info-a@schneeburger.com

BELGIUM, NETHERLANDS and LUXEMBOURG

Phone +31 4 3365 4532
Fax +31 4 3365 3579
Mobil +31 6 5326 3929

E-Mail:
info-nl@schneeburger.com

FRANCE

Phone +33 4 7239 5223
Fax +33 4 7239 5224
Mobil +33 6 0941 6269

E-Mail:
info-f@schneeburger.com

GREAT BRITAIN

Phone +44 16 2582 7708
Fax +44 16 2582 7780
Mobil +44 77 8814 5645

E-Mail:
info-uk@schneeburger.com

ISRAEL

Phone +972 3 546 1082
Fax +972 3 546 1564
Mobil +972 50 551 7920

E-Mail:
info-il@schneeburger.com

KOREA

Phone +82 2442 0971
Fax +82 2442 2971
Mobil +82 1 6202 0971

E-Mail:
info-k@schneeburger.com

POLAND, SLOVAKIA and CZECH REPUBLIC

Phone +420 5 4725 0333
Fax +420 5 4725 0444
Mobil +420 6 0278 4077

E-Mail:
info-cz@schneeburger.com

SPAIN and PORTUGAL

Phone +34 6 4991 9740
Fax +34 9 4687 0973
Mobil +34 6 4991 9740

E-Mail:
info-es@schneeburger.com

RUSSIA, BELARUS and UKRAINE

Phone +38 0542 619 122
Fax +38 0542 619 123
Mobil +38 050 407 6789

E-Mail:
dmitri.kozlov@schneeburger.com