

**SCHNEEBERGER**  
LINEAR TECHNOLOGY

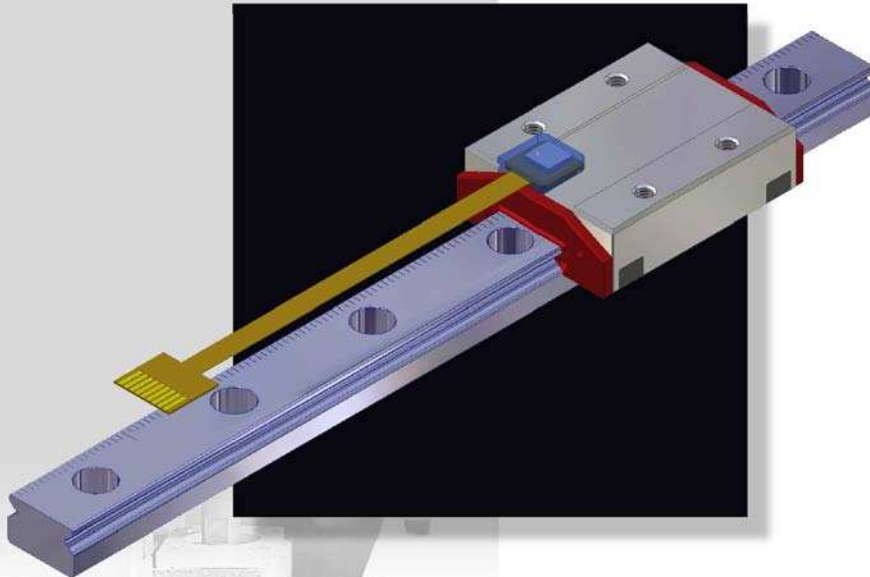

## **MINISCALE**

**the unique miniature guideway  
with integrated measuring  
system**



## MINISCALE - at a glance

Are you looking for a precise and very cost effective linear motion solution with an integrated measuring system?

**Then MINISCALE from SCHEEBERGER is THE choice!**

A precise scale is burned in directly into the surface of the rail of a MINIRAIL miniature guideway. A chip size encoder with built in interpolation provides the digital TTL output signal.

This unique product with a resolution of  $1\ \mu\text{m}$  enables a repeatability of  $\pm 2\ \mu\text{m}$  (bidirectional).

### Benefits:

- guiding & measuring functions combined => all in one
- reduced engineering & assembly time
- excellent price performance ratio

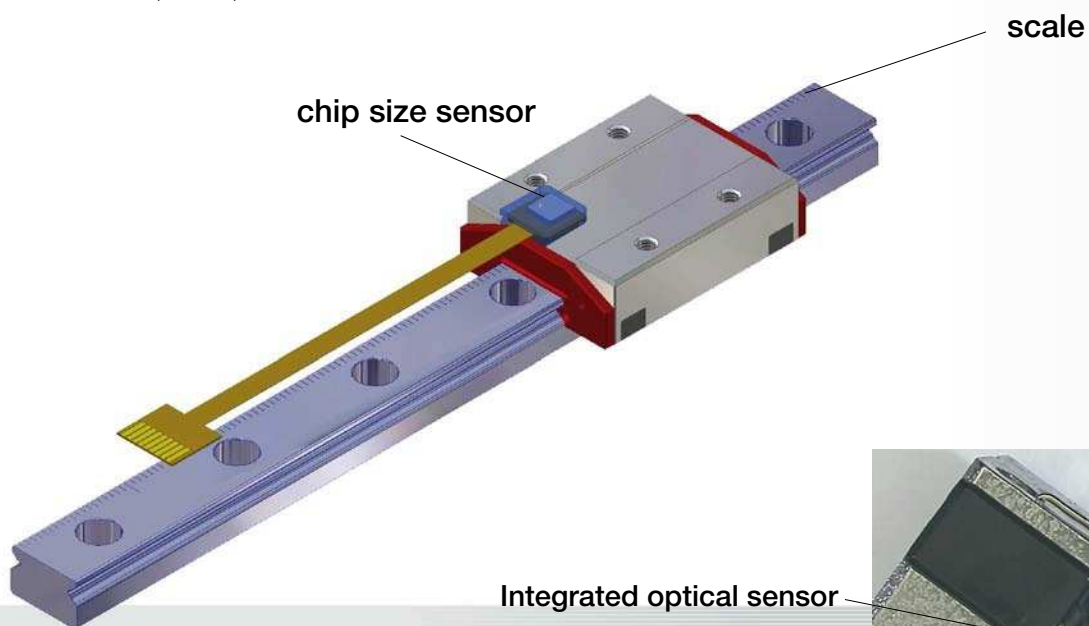

Integrated optical sensor



### Application areas:

- Semiconductor Equipment
- Printing Industry
- Assembly Automation and Robotics
- Metrology
- Biotechnology
- Medical Equipment

**MINISCALE - an excellent cost/performance ratio**

## Specifications

<b>Resolution</b>		1 $\mu\text{m}$
<b>Accuracy</b>	up to 30 mm up to 300 mm	+/- 4 $\mu\text{m}$ (+/- 3 $\mu\text{m}$ on request) +/- 10 $\mu\text{m}$
<b>Repeat Accuracy</b>	unidirectional bidirectional	+/- 1 $\mu\text{m}$ +/- 2 $\mu\text{m}$
<b>Scale</b>	grating pitch max. length	40 $\mu\text{m}$ 300 mm
<b>Rail</b>	sizes quality preload length	7, 9, 12, 15 and 14, 18, 24, 42 G1 V1 max. 600 mm
<b>Speed</b>		max. 5 m/s
<b>Acceleration</b>		max. 30 g
<b>Sensor</b>	lifetime shock vibration	100 000 h MTTF (mean time no failure) 300 g 30 g (20 Hz)
<b>Power Supply</b>		5 VDC +/- 5 % @20 mA
<b>Output Signal</b>		CMOS/TTL compatible, 60 Ohm
<b>Interface</b>		FPCB (flexible printed circuit board) with 10-pin ZIF-connector (1 mm grating pitch). Total length 67 mm, permitted bending radius > 10 mm
<b>RoHS Compatibility</b>		MINISCALE will comply with the directive 2002/95/EC as from 2009 on
<b>Electromagnetic Compatibility (EMC)</b>		EN 61000-6 compliant according EEC/89/336
<b>Protection Class</b>		IP 60
<b>Environmental Influences</b>	temperature humidity magnetism vacuum	operating: 0° to 70° C (32° to 158° F) storage: - 20° to 100° C (- 4° to 212° F) 10 % - 90 % (relative humidity not condensing) no influence not possible



## MINISCALE - dimensions

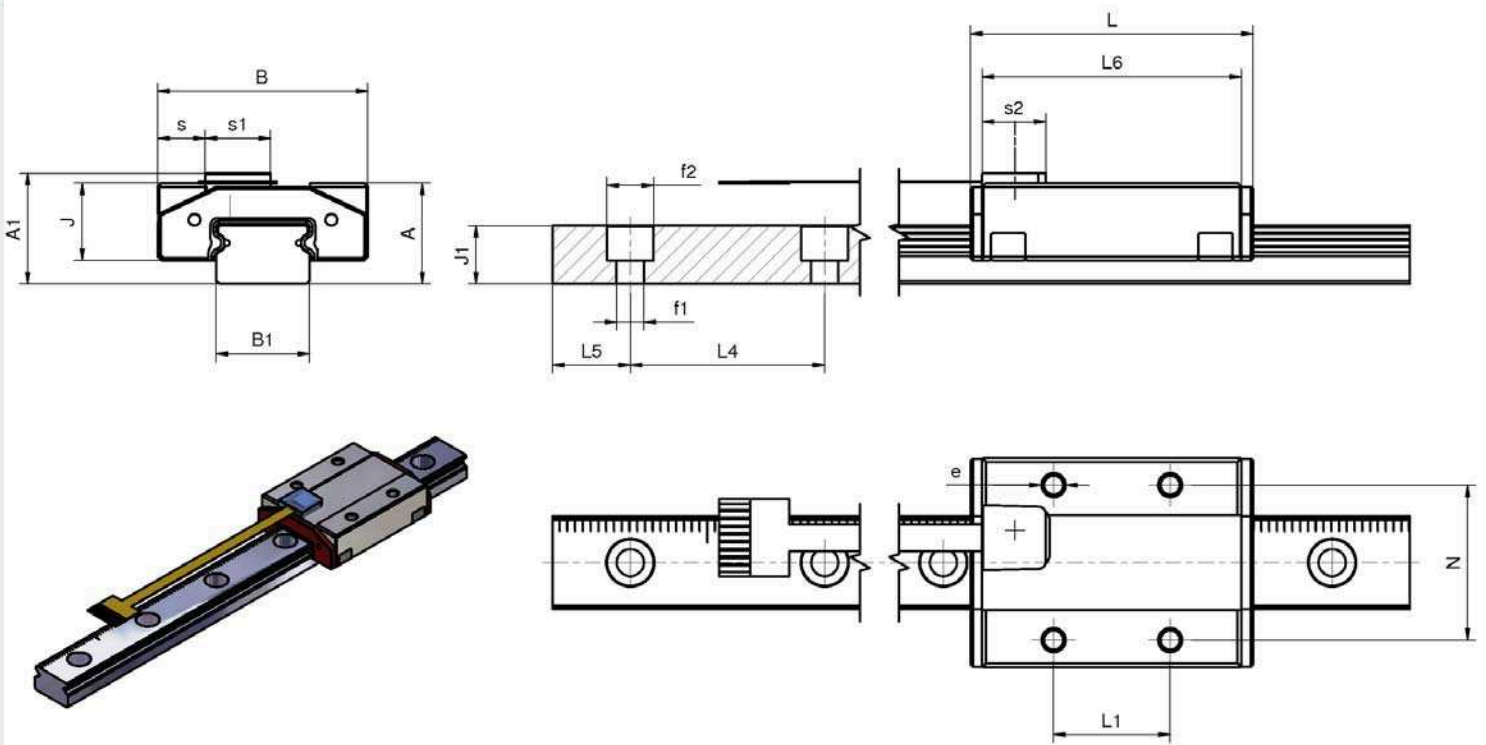

Type	Dimensions [mm]																		
	A	A1	B	B1	s	s1	s2	J	J1	L	L1	L4	L5	L6	N	e	f1	f2	
<b>standard sizes</b>																			
<b>MNS 7</b>	8	11.5	17	7	3.3	8.4	8	6.5	4.5	24.6	8	15	5	22.1	12	M2	2.4	4.2	
<b>MNS 9</b>	10	12.5	20	9	3.75	8.4	8.2	8	5.5	32	10	20	7.5	29	15	M3	3.5	6	
<b>MNS 12</b>	13	14.5	27	12	6.1	8.4	8.2	10	7.5	36.4	15	25	10	33.4	20	M3	3.5	6	
<b>MNS 15</b>	16	16	32	15	7.45	8.4	8.2	12	9.5	43.7	20	40	15	40.7	25	M3	3.5	6	
<b>wide sizes</b>																			
<b>MNS 14</b>	9	12	25	14	4.15	8.4	8.2	6.8	5.2	32.1	10	30	10	29.6	19	M3	3.5	6	
<b>MNS 18</b>	12	14	30	18	4.75	8.4	8.2	8.5	7	40	12	30	10	37	21	M3	3.5	6	
<b>MNS 24</b>	14	15.5	40	24	6.6	8.4	8.2	10	8.5	46.4	15	40	15	43.4	28	M3	4.5	8	
<b>MNS 42</b>	16	16	60	42	7.95	8.4	8.2	12	9.5	55.7	20	40	15	52.7	45	M4	4.5	8	

For more detailed technical data please refer to the SCHNEEBERGER MINIRAIL catalogue

[www.schneeberger.com](http://www.schneeberger.com)



**INDIA**  
 SCHNEEBERGER India Private Limited  
 Dhannur, 2nd Floor 15 Sir P M Road, Fort  
 400 001 Mumbai  
 Phone +91 22 2263 2372  
 Fax +91 22 2263 2371  
 E-Mail:  
 info-in@schneeberger.com

**CZECH REPUBLIC**  
 SCHNEEBERGER Mineralgusstechnik s.r.o.  
 Prumyslový park 32/20  
 350 02 Cheb - Dolní Dvory  
 Phone +420 354 400 941  
 Fax +420 354 400 940  
 E-Mail:  
 info-mineralguss@schneeberger.com

**SWITZERLAND**  
 SCHNEEBERGER AG  
 St. Urbanstrasse 12  
 4914 Roggwil/BE  
 Phone +41 62 918 41 11  
 Fax +41 62 918 41 00  
 E-Mail:  
 info-ch@schneeberger.com

**GERMANY**  
 SCHNEEBERGER GmbH  
 Grafenau, Postfach 70  
 75339 Höfen/Enz  
 Phone +49 7081 782 0  
 Fax +49 7081 782 124  
 E-Mail:  
 info-d@schneeberger.com

**ITALY**  
 SCHNEEBERGER S.r.l.  
 Piazza Aldo Moro, 2  
 21018-Sesto Calende (VA)  
 Phone +39 0331 93 2010  
 Fax +39 0331 93 1655  
 E-Mail:  
 info-i@schneeberger.com

**USA**  
 SCHNEEBERGER Inc.  
 11 DeAngelo Drive  
 Bedford, MA 01730  
 Phone +1 781 271 0140  
 Fax +1 781 275 4749  
 E-Mail:  
 info-usa@schneeberger.com

**CHINA**  
 SCHNEEBERGER (Shanghai) Co., Ltd.  
 Rm 406, Victorie Businessbuilding C,  
 No.96 Ronghua Rd.(E) Gubei New Area  
 201103 Shanghai  
 Phone +86 21 6209 0037 / 27  
 Fax +86 21 6208 5488  
 E-Mail:  
 info-cn@schneeberger.com

**JAPAN**  
 Nippon SCHNEEBERGER KK  
 Shimouma Miyagawa Bld 4F  
 1-49-12 Shimouma  
 154-0002 Tokyo  
 Phone +81 3 5779 7339  
 Fax +81 3 3487 6010  
 E-Mail:  
 info-j@schneeberger.com