

# **SEALMASTER**<sup>®</sup>

*PERFORMANCE WITHOUT COMPROMISE*

## **DESIGN**



## **DEVELOP**

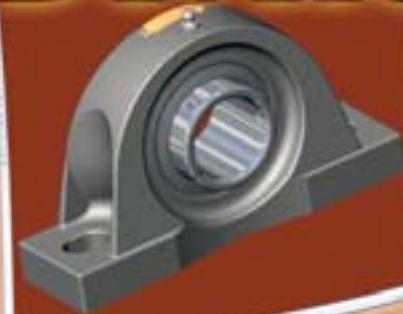

*CUSTOM SELECT™  
Handbook*

## **DELIVER**



Emerson Power  
Transmission  
[www.emerson-ept.com](http://www.emerson-ept.com)

**EMERSON**  
Industrial Automation

## Table of Contents

Application Reference Guide .....	Page 3
Custom Designs .....	Pages 4-5
High Temperature Options .....	Pages 6-7
High Contamination Options .....	Pages 8-9
Low Drag Options .....	Pages 10-11
Air Handling Options .....	Pages 12-13
High Speed Options .....	Page 14
Low Temperature Options .....	Page 15
Optional Fittings .....	Page 16
Other/Additional Applications .....	Page 17
Speed Table .....	Page 18
Load Table .....	Page 19
CUSTOM SELECT™ Availability .....	Pages 20-22
Standard Conditions and Terms of Sale .....	Page 23

**Application Reference Guide - *CUSTOM SELECT™***

**High Temperature Pages 6-7**

Suffix	Description	Temperature	Environment
HT*	Standard High Temp	200°F to 400°F	Dry/Dusty
HI*	High Performance High Temp	200°F to 400°F	Dry/Dusty
HTA*	High Temp Air Handling	200°F to 400°F	Dry/Dusty
HTC*	High Temp Contact Seal	200°F to 400°F	Wet/Moisture

**High Contamination Pages 8-9**

Suffix	Description	Temperature	Environment
DRT	Highly Contaminated	-50°F to 200°F	Highly Contaminated

**Low Drag Pages 10-11**

Suffix	Description	Temperature	Environment
LO	Low Drag	-20°F to 180°F	Dry/Dusty
XLO	Extra Low Drag	-50°F to 100°F	Dry/Dusty

**Air Handling Pages 12-13**

Suffix	Description	Temperature	Environment
CXU	Air Handling	-50°F to 200°F	Dry/Dusty
HTA*	High Temp Air Handling	200°F to 400°F	Dry/Dusty

**High Speed Page 14**

Suffix	Description	Temperature	Environment
HS	High Speed	-50°F to 200°F	Dry/Dusty

**Low Temperature Page 15**

Suffix	Description	Temperature	Environment
LT	Low Temperature	-65°F to 200°F	Dry/Dusty

**Optional Fittings Page 16**

Suffix	Description	Temperature	Environment
CSK	90° Grease Fitting	-50°F to 200°F	-
CTJ	Adaptor and Plug	-50°F to 200°F	-
CSJ	45° Grease Fitting	-50°F to 200°F	-
W	Adaptor and Grease Fitting	-50°F to 200°F	-
CTY	Plug	-50°F to 200°F	-

**Other/Additional Applications Page 17**

Suffix	Description	Temperature	Environment
Specified by Application	Thousands of Applications Not Listed in This Catalog	Varied by Application	Your Application

Visit [www.emerson-ept.com/SMcustom](http://www.emerson-ept.com/SMcustom) for web product selection tool

\*For expansion units add an E prefix (High Temperature and High Temperature Air Handling Units Only)

## Reputation Built on Innovation

Since its inception over sixty years ago, the name SEALMASTER has been synonymous with industry-leading product innovation and application-focused solutions. With its original platform, born out of the world's most demanding environments, the Gold Line list of features remain, to this day, the pinnacle by which all other designs are measured. From the very beginning, employees have built a solid foundation of continued innovation by working with and understanding the specific needs of contractors, processors, and key equipment manufacturers around the world. This working relationship has allowed us to **Design, Develop and Deliver** tailored bearing solutions one application at a time...

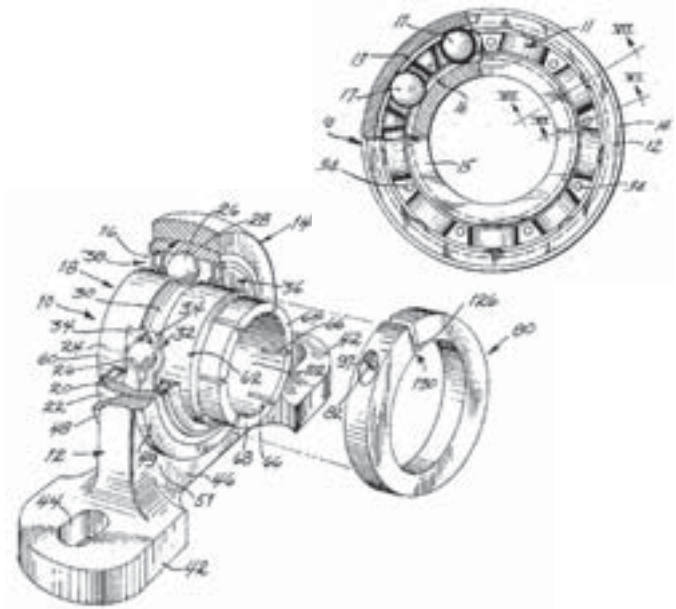

## Application Engineering Support

To support its broad and evolving customer base, SEALMASTER relies on its experienced Application Engineers (AE) specializing in specific industries and mounted bearing designs. When contacted, each AE reviews application parameters, environmental conditions, and business requirements before recommending a solution. In some cases, depending on the nature of the application, the AE may choose to construct an original and unique bearing design specially manufactured to meet the customer's precise specifications.

## Technical Customer Service

Working in tandem with Application Engineers are the Technical Customer Service Representatives. The TCSR group assists customers with broad based technical inquiries ranging from product nomenclature and interchanges, to grease and dimensional specifications.



## Electronic Technical Support

In addition to these departmental resources, EPT also offers a variety of e-commerce solutions designed to improve business efficiencies and productivity. Some of these solutions include: Product Selection Tools, Electronic Product Catalogs, Product Interchange Guides, 2D and 3D CAD Downloadable Templates, and an extensive Electronic Media Library.

## Thousands of Combinations... **CUSTOM SELECT™**

Bearings are typically selected using L10 fatigue life calculations based on ideal operating conditions. However, most bearing problems are not fatigue related, but occur due to contamination, lubrication starvation, or other environmental issues. Our engineers realize that bearing applications vary widely in severity, operating parameters, and maintenance regularity. In fact, most applications are not ideal, thus bearings are usually replaced for reasons other than general fatigue.

When your application is challenging enough to demand more than a standard bearing, you literally have thousands of configuration options with SEALMASTER brand bearings. By modifying component attributes such as lubrication type, internal radial clearance, seal selection, and housing fit, engineers can optimize system uptime and equipment performance.

### **Gold Line**



#### **Gold Line Platform**

- Proven Performance for Over 60 Years
- Felt Labyrinth Seals
- Solid Cast Iron Housing
- 120° Set Screw Placement
- Zone Hardened Inner Race
- ±2-3° Misalignment Capability
- Expansion Designs Available
- Unique Land Riding Brass Retainer
- Exclusive Lock Pin and Dimple System
- Black Oxide Coated - Wide Inner and Outer Races
- Locking Options: Single/Double Set Screw, SKWEZLOC Concentric Collar

**PERFORMANCE  
WITHOUT  
COMPROMISE**

### **CUSTOM SELECT™**

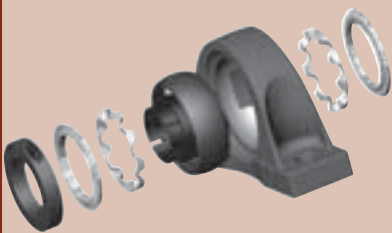

#### **Application Specific Designs**

- High Speed Applications: HS
- Air Handling Applications: CXU, HTA
- Low Drag Requirements: LO, XLO
- Low Temperature Applications: LT
- High Contamination Environments: DRT
- Grease Fitting Options: CSK, CTJ, CSJ, W
- High Temperature Applications: HT, HTC, HTA, HI
- Other Additional Applications: See Page 17

**CUSTOM  
SELECT™...  
Ready to Ship in 9  
Days or Less \***

**\* For Quantities Over  
25 Pieces  
Consult EPT  
Customer Service**

### **Engineered Custom Designs**



- Special Housing/Bearing Dimensions
  - Units built to match your machine requirements
  - Tolerances controlled to your application
- Unique Components Matched To Your Application
  - Provides performance enhancements
  - Designs that solve problems
- Integrate multiple Machine Elements Into Unitized Bearing
  - Ease of assembly
  - Reduction of components, inventory, and vendors

**Flexible  
Manufacturing  
Processes for  
Almost Any  
Modification!**

## High Temperature Options



Design				Develop	Deliver
Step 1:	Step 2:	Step 3:	Step 4:	Step 5:	Step 6:
Temperature Range	Application Considerations	Verify Speed Limitations	Verify Loading Conditions	Determine Suffix	Add Prefix/Suffix to Desired Bearing - Add E Prefix for Expansion (Examples Below)
200°F to 400°F	Standard High Temp Dry/Dusty Environment	See Page 18	See Page 19	<b>HT</b>	NP-16 ENP-16 → NP-16 HT ENP-16 HT
200°F to 400°F	Extended Relubrication Intervals Dry/Dusty Environment	See Page 18	See Page 19	<b>HI</b>	MSF-20 EMSF-20 → MSF-20 HI EMSF-20 HI
200°F to 400°F	Air Handling Applications Dry/Dusty Environment	See Page 18	See Page 19	<b>HTA</b>	MP-23 EMP-23 → MP-23 HTA EMP-23 HTA
200°F to 400°F	Standard High Temp Wet/Washdown Environment	See Page 18	See Page 19	<b>HTC</b>	SF-16 ESF-16 → SF-16 HTC ESF-16 HTC

Refer to pages 20-21 for bore size and housing type availability

Dimensional data available at [www.emerson-ept.com/SMcustom](http://www.emerson-ept.com/SMcustom) or in Catalog BP-97

**HT:** \*NOMEX Seal, Synthetic High Temperature Grease, Increased Internal Clearance

**HI:** \*NOMEX Seal, \*KRYTOX-226 Grease, Increased Internal Clearance

**HTA:** \*NOMEX Seal, Synthetic High Temperature Grease, Increased Internal Clearance, Air Handling Housing Fit, Noise Test

**HTC:** High Temperature Contact Seals, Synthetic High Temperature Grease, Increased Internal Clearance

When a bearing is not designed for high temperature applications, frequent replacement and limited bearing life often leads to high operational cost. Engineers from the world famous SEALMASTER brand bearings have experience in designing and manufacturing bearings to operate in temperatures up to 400°F.

The brass alloy retainer will not oxidate or melt like polymer retainers, provides superior lubricity, and decreased galling compared with steel retainers. High temperature bearings offer you the choice of either a synthetic high temperature lubricant or high performance \*KRYTOX-226. Various seal options allow you to select the optimum solution based on your specific application environment. In addition, expansion bearings are available to accommodate axial shaft expansion due to temperature differentials.

High temperature bearings are used on:

- Industrial Furnaces
- Bakery Ovens



- Incinerators
- Heat Treat Equipment

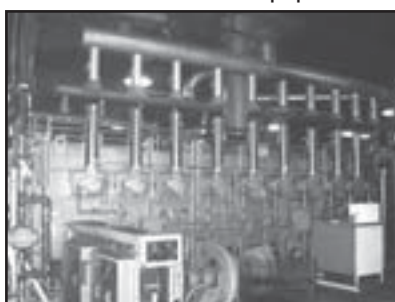

- Fans & Blowers (see HTA)
- Drying Ovens



\*NOMEX and \*KRYTOX are registered trademarks of E. I. du Pont de Nemours and Company.

These trade names, trademarks and/or registered trademarks are the property of their respective owners and are not owned or controlled by Emerson Power Transmission Corporation (EPT). EPT does not represent or warrant the accuracy of this document.

## Brass Land Riding Retainer

- Brass alloy for exceptional performance in high temperature applications
- High strength riveted two-piece design
- Land riding design for greatly improved grease distribution
- Combined with wide outer race, grease capacity is increased up to 30%



## Grease

Optional greases for elevated temperature operation:

### Synthetic High Temperature

- Used in HT, HTA, and HTC suffix modified bearings
- High quality, synthetic hydrocarbon, lithium complex thickened grease NLGI#2, and ISO 220 viscosity
- Superior high temperature (200°F to 400°F) stability

### \*KRYTOX Extended Lube

- Used in HI suffix modified bearings
- \*KRYTOX GPL 226, an extremely high performance perfluorinated oil and PTFE thickened grease
- \*KRYTOX grease has a superior service life and therefore diminishes re-lubrication frequency and extends life
- Engineers have found that, compared to other high temperature greases, the thermal stability and lubricity of \*KRYTOX can improve high temperature bearing life by a factor of 4 to 45 times.



## Seals

### \*NOMEX High Temperature Material

- High performance sealing capability in dry or dusty environments
- \*NOMEX is most commonly associated with its use in fire retardant clothing

### High Temperature Contact Seal

- For use in applications where moisture, water, or wash down conditions are present
- Made of tough, wear and heat resistant materials



**\*NOMEX Seal**

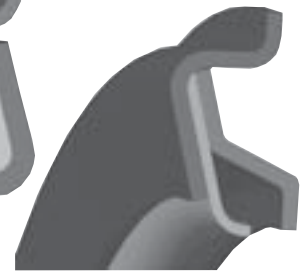

**High Temperature Contact Seal**

## Non-Expansion (Fixed) or Expansion (Float)

Axial shaft expansion is compensated by a non-expansion (fixed) and expansion (float) arrangement. High temperature bearings are offered in both fixed and float arrangements and have identical mounting dimensions. It is recommended to use both units on one shaft in high temperature applications to help account for linear shaft expansion. Expansion bearings are available in the ENP, ESFT, ESF, EMP, and EMSF housing styles.

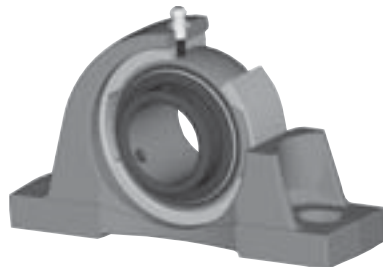

Bore Size	Expansion Capability
3/4" - 1 3/4"	1/8"
1 15/16" - 2 7/16"	3/16"

## Internal Clearance

- Factory pre-set with additional internal clearance
- Bearings can seize due to differential in inner ring/outer ring expansion from temperature fluctuations unless appropriate radial clearance is provided

**For expansion capabilities greater than listed above or hollow shafts heated by elevated temperature liquids, consult Application Engineers at (630) 898-9620.**

\*NOMEX and \*KRYTOX are registered trademarks of E. I. du Pont de Nemours and Company. These trade names, trademarks and/or registered trademarks are the property of their respective owners and are not owned or controlled by Emerson Power Transmission Corporation (EPT). EPT does not represent or warrant the accuracy of this document.

## High Contamination Options



Design				Develop	Deliver
Step 1:	Step 2:	Step 3:	Step 4:	Step 5:	Step 6:
Temperature Range	Application Considerations	Verify Speed Limitations	Verify Loading Conditions	Determine Suffix	Add Suffix to Desired Bearing (Example Below)
-50°F to 200°F	Highly Contaminated Low Speed Applications	See Page 18	See Page 19	<b>DRT</b>	MP-24 → MP-24 DRT

Refer to pages 20-21 for bore size and housing type availability

Dimensional data available at [www.emerson-ept.com/SMcustom](http://www.emerson-ept.com/SMcustom) or in the Catalog BP-97

**DRT:** Heavy Duty Multi-lip Seal, 100% Grease Fill

Applications with high levels of environmental and airborne contamination can accelerate the wear pattern in standard bearings. Contamination erodes standard seals, enters the bearing cavity, and creates indentations in the raceway. These indentations become stress concentration points which decrease bearing life. In extreme conditions, the contaminants fill the internal cavity and prevent the bearing from rotating. Foreign material prevents the grease from adequately lubricating the raceways and balls. These conditions lead to shortened operational life and frequent bearing replacement. The DRT seals utilize a unique multiple-component design that outperforms common multi-lip molded designs in harsh applications. The 100% grease fill, along with the standard increased capacity of the wide outer race design, allows greater protection against foreign material entering the bearing cavity.

High contamination bearings are used on:

- Agricultural Equipment
- Foundry Equipment
- Construction Equipment
- Aggregate Conveyors
- Bulk Powder Conveyors

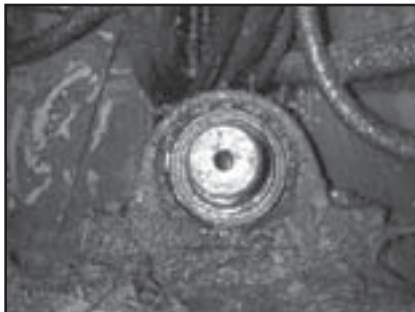



## Seals

- Available with either double lip or triple lip contact seals depending on bore size
- Multi-piece component design greatly enhances performance over single molded multi-lip design
- Nitrile seal washers are reinforced with a fabric weave and provide excellent sealing in wet, dirty applications
- The washers are captured between two metal stampings that provide additional protection for the seal lips and bearing cavity



**Double Lip Contact Seal**



**Triple Lip Contact Seal**



## Wide Outer Race

- Outer races have the largest internal grease capacity in the industry (10-30% wider) that allows for longer intervals between lubrication and longer useful bearing life
- Improved grease capacity provides additional sealing performance

## Exclusive Lock Pin & Dimple

- Patented lock pin and dimple direct-lubrication system consists of a lock pin that extends directly beneath the grease fitting
- Direct lubrication path into the bearing allows excess grease to purge contamination from the bearing cavity

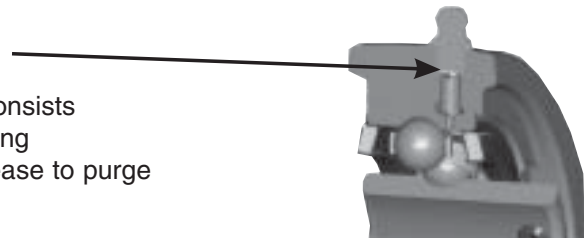

## Grease

- Exclusive GOLDPLEX™-HP High Performance Mounted Bearing Grease, specifically formulated for SEALMASTER Brand Bearings
- GOLDPLEX™-HP features corrosion enhancing properties
- DRT suffix has a 100% grease fill to further reduce the possibility of contamination entering the bearing cavity



## Grease Fitting Caps

- Grease fitting caps protect the zerk fitting from contamination

## Brass Land Riding Retainer

- Land riding design allows for 360° circulation of lubricant around the rolling elements and ball paths
- Collection of grease in the retainer's recessed ball pockets allows for gradual release of oil as needed
- Combining the wide outer race with this retainer design results in up to 30% added grease capacity



## Low Drag Options



Design				Develop	Deliver
Step 1:	Step 2:	Step 3:	Step 4:	Step 5:	Step 6:
Temperature Range	Application Considerations	Verify Speed Limitations	Verify Loading Conditions	Determine Suffix	Add Suffix to Desired Bearing (Example Below)
-20°F to 180°F	Grease Filled Low Drag Dry/Dusty Environment	See Page 18	See Page 19	<b>LO</b>	NP-10 → NP-10 LO
-30°F to 100°F	Oil Lubricated Extra Low Drag Dry/Dusty Environment	See Page 18	See Page 19	<b>XLO</b>	SFT-16 → SFT-16 XLO

Refer to pages 20-21 for bore size and housing type availability

Dimensional data available at [www.emerson-ept.com/SMcustom](http://www.emerson-ept.com/SMcustom) or in the Catalog BP-97

**LO:** Cut Down Felt Seals, Channeling Grease  
**XLO:** Cut Down Oil Soaked Felt Seals, Oil Lubricated

Low drag bearings have modifications suited for applications where reduced drag or lower rotational torque is required, while maintaining a high level of seal effectiveness (see chart on following page). Printing and packaging machinery weave sheets of material through webs that are composed of hundreds of rolls. Typical applications where roller drag can be an issue include cutting, heating, drying, folding, stacking, and finishing. XLO modifications are suited for minimum drag which is approximately 10% of the standard felt seal drag. LO modifications are approximately 50% of the drag of the standard felt sealed bearing, but typically have longer service life compared to the XLO (unless the XLO is frequently relubricated with oil).

Low drag bearings are used on:

- Paper Webs
- Printing Equipment
- Plastic Film Processing Equipment
- Packaging Machinery



## Seals

### SEALMASTER® BRAND LO DRAG FELT

The advanced LO DRAG felt labyrinth seal with rotating flinger is designed to direct contamination away from the sealing surface and reduce rotational torque. Unlike most low drag seal designs, the LO DRAG felt seal provides an excellent barrier which works to retain grease and acts as a filter to reduce the ingress of debris.



### SEALMASTER® BRAND X-TRA LO DRAG

The X-TRA LO DRAG felt labyrinth seal is the same as the LO DRAG felt seal with one difference; it is soaked in oil to act as a lubrication reservoir and lower seal friction.

## Product Comparisons

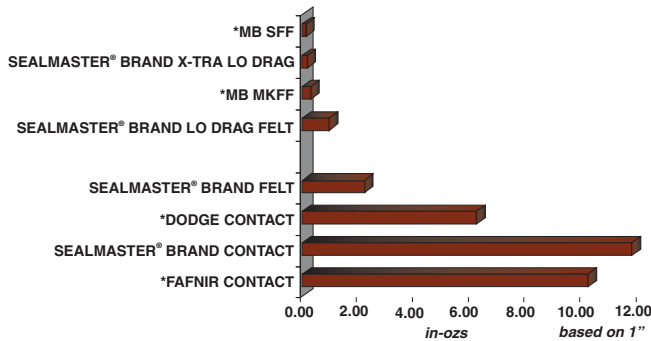

**Seal Drag**

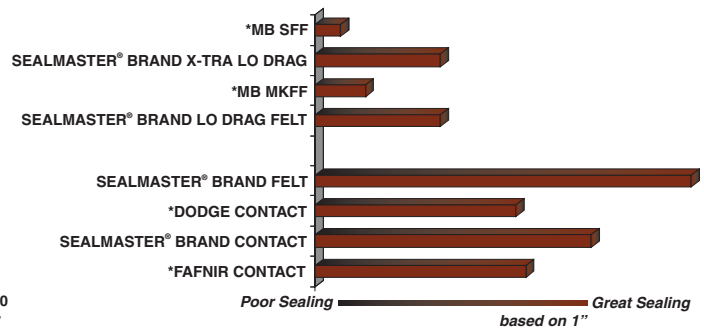

**Sealing Effectiveness**

Note: Grease lubrication will increase useful bearing life over oil.

## Lubrication

- LO suffix features a channeling grease which reduces bearing rotational drag while lubricating the internal bearing components
- XLO suffix is lubricated with oil to further reduce bearing rotational drag



## Housing Fit Up

- A reduced housing fit (LO and XLO) allows the bearing to misalign more easily in the housing
- Effectively increases the useful life of the bearing by properly aligning the inner race with the outer race

## Selection of XLO and LO

- XLO modified bearings should be frequently lubricated with oil to increase bearing life. LO offers an alternative for bearings which cannot be lubricated and require longer bearing life (than XLO) in applications that can operate with the higher rotational torque values.

\*MB is a trademark of Rexnord Industries, Inc.

\*DODGE is a trademark of Reliance Electric Company.

\*FAFNIR is a trademark of the Torrington Company.

These trade names, trademarks and/or registered trademarks are used herein for product comparison purposes only, are the property of their respective owners and are not owned or controlled by Emerson Power Transmission Corporation (EPT). EPT does not represent or warrant the accuracy of this document.

## Air Handling Options



Design				Develop	Deliver
Step 1:	Step 2:	Step 3:	Step 4:	Step 5:	Step 6:
Temperature Range	Application Considerations	Verify Speed Limitations	Verify Loading Conditions	Determine Suffix	Add Prefix/Suffix to Desired Bearing -Add E Prefix for High Temp Expansion (Examples Below)
-50°F to 200°F	Dry/Dusty Environments	See Page 18	See Page 19	<b>CXU</b>	MP-16 → MP-16 CXU
200°F to 400°F	High Temperature Applications Dry/Dusty Environment	See Page 18	See Page 19	<b>HTA</b>	MP-23 EMP-23 → MP-23 HTA EMP-23 HTA

Refer to pages 20-21 for bore size and housing type availability

Dimensional data available at [www.emerson-ept.com/SMcustom](http://www.emerson-ept.com/SMcustom) or in the Catalog BP-97

**CXU:** Air Handling Housing Fit, Felt Seal, Noise Test

**HTA:** \*NOMEX Seal, Synthetic High Temperature Grease, Increased Internal Clearance, Air Handling Housing Fit, Noise Test

Air handling bearings are uniquely designed for the demands of air handling units. Fans and blowers frequently operate at higher speeds than typical industrial equipment and must operate with low noise levels. All Air-Handling bearings have honed raceways and go through a two-stage noise test verification procedure for quiet operation. The effects of speed and vibration on fan and blower applications can significantly reduce bearing and fan system life. SEALMASTER® SKWEZLOC® locking system maintains ball path roundness and centers the shaft in the bore, reducing noise and vibration in the system. To improve bearing alignment, even in lightweight frame applications, CXU and HTA units are equipped with controlled air handling housing fit. Bearings with contact seals typically result in higher drag and can add to the energy costs of the system and reduce bottom line profits. Air handling units utilize a felt seal designed for decreased energy consumption.

Air Handling Bearings are used on:

- Fans
- Blowers



\*NOMEX is a registered trademark of E. I. du Pont de Nemours and Company. The trade names, trademarks and/or registered trademarks are the property of their respective owners and are not owned or controlled by Emerson Power Transmission Corporation (EPT). EPT does not represent or warrant the accuracy of this document.

## SKWEZLOC Concentric Lock

- SEALMASTER® SKWEZLOC® locking system utilizes a locking collar placed over the inner race having six evenly spaced tabs that when tightened compress concentrically around the shaft
- This design operates with minimal runout for less vibration and maintains as manufactured ball path roundness
- Add T suffix - NP-16T CXU



## Double Lock



- Air handling units are also available with double lock locking system
- Double set screw lock utilizes the 120° set screw position and four diamond faceted set screws rather than the traditional two
- This exclusive design offers increased holding power and lock reliability on standard and stainless steel shafting
- Add D suffix - NPD-16 CXU

## Wide Inner Race and Zone Hardening

- Wide inner race offers increased shaft support which will reduce fretting wear and leads to reduced vibration and allows smooth, quiet operation
- This design also incorporates a zoned hardened inner race, which only hardens the ball path and allows the edge of the races to remain ductile to absorb shock and resist cracking

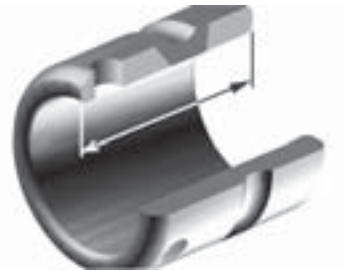

## Solid Housing Base

- A rugged housing has a machined solid base for improved stability and resistance to shock and vibration
- Solid foot pad reduces frame degradation

## Housing Fit Up

- Air handling units are manufactured with a distinct AH housing fit that allows the bearing to properly self-align when mounted on lightweight frames. Improper self-alignment creates high-stress zones between the ball and ball-path that can significantly reduce bearing life.
- Specially designed grease that lubricates the surface between the bearing OD and the housing bore reduces the tolerance range of allowable bearing misalignment torque. This narrow tolerance range allows the misalignment torque to be designed specifically for high speed operation.



## Seals

- CXU units utilize the patented felt seal with unique labyrinth design that retains grease and filters contaminants. The design incorporates a flinger to sling contamination away from the seal while the felt helps filter out airborne particles.
- HTA units come with \*NOMEX high temperature material seals
- Results in reduced energy consumption

## Noise Testing

- 100% noise test provides consistently low operating noise level

\*NOMEX is a registered trademark of E. I. du Pont de Nemours and Company.

The trade names, trademarks and/or registered trademarks are the property of their respective owners and are not owned or controlled by Emerson Power Transmission Corporation (EPT). EPT does not represent or warrant the accuracy of this document.

## High Speed Options



Design				Develop	Deliver
Step 1:	Step 2:	Step 3:	Step 4:	Step 5:	Step 6:
Temperature Range	Application Considerations	Verify Speed Limitations	Verify Loading Conditions	Determine Suffix	Add Suffix to Desired Bearing (Example Below)
-50°F to 200°F	SKWEZLOC Only Dry/Dusty Applications	See Page 18	See Page 19	<b>HS</b>	NP-12 → NP-12 HS

Refer to pages 20-21 for bore size and housing type availability

Dimensional data available at [www.emerson-ept.com/SMcustom](http://www.emerson-ept.com/SMcustom) or in the Catalog BP-97

**HS:** Increased Internal Clearance, Backed Off Felt Seal, Special Housing Fit, GOLDPLEX™-HP Grease, Available with SKWEZLOC® Locking Only

High speed bearings accommodate a variety of high speed applications. High speed fans and blowers, wood working saws and routers, polishing and grinding equipment often operate at speeds that are outside the capabilities of standard ball bearings. These high speed applications distress the lubricant, increase the seal and bearing operating temperature, and cause unacceptable levels of vibration.

High speed bearings are used on:

- Fans
- Blowers
- Polishing Equipment
- Wood Working Saws



### Backed Off Felt Seal

- Similar to the standard felt seal with reduced contact area between the felt sealing material and the rotating metal flinger
- The backed off felt seal is designed to offer high performance sealing while reducing the frictional heat associated with high speed operation

### Housing Fit Up

- Derived from and similar in nature to the housing fit used for HVAC units
- Distinct housing fit that allows the bearing to properly self-align
- Improper self-alignment creates high-stress zones between the ball and ball-path that can significantly reduce bearing life



### SKWEZLOC Concentric Lock

- SEALMASTER® SKWEZLOC® locking system utilizes a locking collar placed over the inner race having six evenly spaced tabs that when tightened compress concentrically around the shaft
- This design eliminates burring on stainless steel shafting from set screws

**Note:**

1. Shaft tolerances are critical for high speed applications. Consult page 21.
2. Not recommended for vertical shaft applications. Consult Application Engineering.
3. A load range of (0.01 to 0.05) x (Basic Dynamic Radial Rating) is recommended to reduce ball skidding and excess heat generation. See page 19 for Basic Dynamic radial rating values.

Consult [www.emerson-ept.com/SMcustom](http://www.emerson-ept.com/SMcustom) for lubrication information.

## Low Temperature Options



Design				Develop	Deliver
Step 1:	Step 2:	Step 3:	Step 4:	Step 5:	Step 6:
Temperature Range	Application Considerations	Verify Speed Limitations	Verify Loading Conditions	Determine Suffix	Add Suffix to Desired Bearing (Example Below)
-65°F to 200°F	Low Temperature Dry/Dusty Applications	See Page 18	See Page 19	LT	NP-27 → NP-27 LT

Refer to pages 20-21 for bore size and housing type availability

Dimensional data available at [www.emerson-ept.com/SMcustom](http://www.emerson-ept.com/SMcustom) or in the Catalog BP-97

**LT: Synthetic Hydrocarbon Lithium Grease, Modified Internal Clearance, Felt Seal**

Users with bearing applications in low temperature environments are familiar with broken polymer retainers, grease too thick to allow the bearing to operate freely and internal clearances that lead to reduced life. Low temperature bearings feature a full synthetic hydrocarbon ISO 100 grease. The low viscosity of this grease is specifically suited for your low temperature application. Polymer retainers can become brittle in low temperature environments. The high strength brass alloy retainer is designed to address this issue.

- Low temperature bearings are used on:
- Freezers
  - Cold Weather Operation
  - Ski Lifts



### Grease

- Synthetic hydrocarbon lithium complex grease, ISO 100
- ISO 100 allows oil to flow more easily, lubricating components at temperatures as low as -65°F

## Increased Internal Clearance

- Internal clearance allows for internal expansion due to differential temperatures of components

## Optional Fittings



Design				Develop	Deliver
Step 1:	Step 2:	Step 3:	Step 4:	Step 5:	Step 6:
Verify Temperature Range	Applications Considerations	Verify Speed Limitations	Verify Loading Conditions	Determine Suffix	Add Suffix to Desired Bearing (Example Below)
-50°F to 200°F	45° Grease Fitting	See Page 18	See Page 19	<b>CSJ</b>	NP-27 → NP-27 CSJ
-50°F to 200°F	90° Grease Fitting	See Page 18	See Page 19	<b>CSK</b>	NP-27 → NP-27 CSK
-50°F to 200°F	Adaptor and Grease Fitting	See Page 18	See Page 19	<b>W</b>	NP-27 → NP-27 W
-50°F to 200°F	Adaptor and Plug	See Page 18	See Page 19	<b>CTJ</b>	NP-27 → NP-27 CTJ
-50°F to 200°F	Plug	See Page 18	See Page 19	<b>CTY</b>	NP-27 → NP-27 CTY

Refer to pages 20-21 for bore size and housing type availability

Dimensional data available at [www.emerson-ept.com/SMcustom](http://www.emerson-ept.com/SMcustom) or in the Catalog BP-97



### CSJ - 45° Grease Fitting

Allows access to the grease fitting at a 45°.



### CSK - 90° Grease Fitting

Allows access to the grease fitting in the direction of the shaft. The 90° grease fitting would typically be used where an obstruction is located above the bearing.



### W - Adaptor and Grease Fitting

Adaptor allows connectivity with a standard 1/8" lube line. The grease fitting is screwed into the adaptor, allowing the option of lubrication with a grease gun if a lube line is not available.



### CTJ - Adaptor and Plastic Plug

Adaptor allows connectivity with a 1/8" lube line. The plug is pressed into the adaptor to provide protection from contamination when the adaptor is not in use.



### CTY - Plug

The plug is typically specified in place of the grease fitting for applications where it is not beneficial to grease the bearing for compatibility reasons, cleanliness issues, or applications where bearing accessibility is an issue.

#### Note:

1. Fittings are designed to properly position the lock pin anti-rotation device. Other fittings not designed for SEALMASTER brand bearings may not provide this function causing reduced bearing life.
2. Fittings are factory adjusted to properly position the lock pin anti-rotation device. Improper field adjustment of the fitting may cause reduced bearing life. Consult EPT Bearing Technical Services for proper adjustment techniques.



## Other/Additional Applications

The CUSTOM SELECT™, outlined in this catalog, addresses the most common applications that require modifications to reach optimum bearing performance. However, customers consult our Application Engineers daily with a wide variety of problems or requirements not included in CUSTOM SELECT™.

Reviewing your requirements, an engineer may select a combination of features that have been previously designed and proven to be successful in similar applications. When existing solutions do not meet customer requirements, our Application Engineers design a bearing based on your unique parameters utilizing a variety of existing components.

Combining your equipment knowledge and our Application Engineers' bearing expertise, a product solution can be designed to maximize bearing performance in your specific application. Thousands of customers benefit from this capability every year, and now you no longer have to endure the lead time associated with these custom engineered solutions. In many cases, a higher performance product designed and developed specifically for your application is ready to deliver in 9 days.

Our problem solving attitude combined with our flexible manufacturing process creates a new definition of Performance Without Compromise.

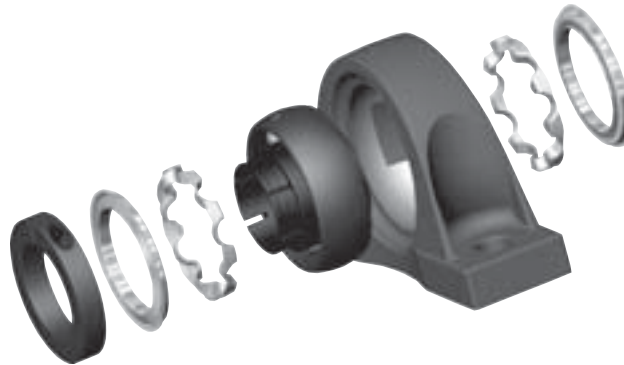

### Application Specific Designs

- 14 Sealing Options
- 2 Retainer Designs
- 7 Coating Options
- 28 Housing Options
- 8 Internal Clearances
- 4 Locking Mechanisms
- 55 Grease Specifications
- 6 Custom Housing Fit-Ups
- 6 Housing Material Options

**Thousands of  
Combinations...  
Limited Only by  
Your Imagination**

**For More Information  
Contact Application  
Engineering**

## Maximum Speed Table

Important- Consult Load Rating Table on Page 19

Shaft Size		High Temperature		Low Drag		Air Handling		High Speed	High Contamination
Normal Duty	Medium Duty	HT, HTA, HI	HTC	LO	XLO	CXU	HTA	HS	DRT
1/2 9/16 5/8 11/16 3/4 20mm	-	3200	1600	5800	2900	7300 10200	3200	11700	1600
13/16 7/8 15/16 25mm 1	-	2750	2500	5000	2500	6350 9000	2750	10200	550
1 1/16 1 1/8 1 3/16 30mm 1 1/4R	15/16 1 25mm	2400	2200	4300	2150	5450 7600	2400	8700	500
1 1/4 1 5/16 1 3/8 35mm 1 7/16	30mm 1 3/16	2200	2000	3700	1850	4650 6500	2200	7450	450
1 1/2 1 9/16 40mm	1 7/16 35mm	1800	1700	3300	1650	4150 5850	1800	6700	400
1 5/8 1 11/16 1 3/4 45mm	1 1/2 45mm	1650	1000	3000	1500	3800 5300	1650	6050	350
1 13/16 1 7/8 1 15/16 50mm 2R	1 11/16 1 3/4 45mm	1550	775	2800	1400	3550 5000	1550	5700	325
2 2 1/8 55mm 2 3/16	1 15/16 50mm	1400	700	2500	1250	3250 4500	1400	5150	300
2 1/4 2 5/16 60mm 2 3/8 2 7/16	55mm 2 3/16	1250	650	2300	1150	3000 4100	1250	4700	650

**SKWEZLOC or Double Lock Speeds Only**

**SKWEZLOC Only**

Optional Fitting Speeds Same as CXU Suffix

## Ball Bearing Rating Table

- This chart displays the CUSTOM SELECT™ ball bearing load capacities for a given L10 life, speed, and shaft size.
- Values in the table represent radial loads at ideal conditions. ABMA recommends derating of slip fit mounted bearings. Elevated operating temperatures can reduce the load capacity of bearing steel.
  - For operating temperatures up to 200°F, divide the value in the load table by 1.3 to obtain the slip fit derated value.
  - For operating temperatures 200°F to 400°F, divide the value in the load table by 1.5 to obtain the slip fit/elevated temperature derate value.
  - Values in the table represent equivalent radial loads only. For combined radial/thrust loads consult BP-97 Catalog.
- Double lock and SKWEZLOC use same bearing insert ratings as single lock inserts shown below.

Important- Consult Maximum Speed Table on Page 18 for specific suffix.

## Load Ratings - Ball Bearings

STANDARD DUTY		MEDIUM DUTY		BASIC DYNAMIC RADIAL RATING	L10 HOURS	REVOLUTIONS PER MINUTE																	
SHAFT SIZE	INSERT #	SHAFT SIZE	INSERT #			50	500	1000	1750	2000	3000	3500	4000	4500	5000	5500	6000	6500	7500	8000	8500	10000	11000
1/2	2-08			2611	5000	619	491	390	324	310	270	257	246	236	228	221	215	209	199	195	191	181	130
9/16	2-09				10000	583	390	310	257	246	215	204	195	188	181	175	170	166	158	154	152	143	130
5/8	2-010	-	-		30000	583	270	215	178	170	149	141	135	130	126	122	118	115	109	107	105	100	97
11/16	2-011				50000	491	228	181	150	144	126	119	114	110	106	103	100	97	92	90	89	84	81
3/4	2-012				100000	390	181	144	119	114	100	95	91	87	84	81	79	77	73	71	70	67	65
20mm	5204																						
13/16	2-013			2801	5000	664	527	418	347	332	290	276	264	253	245	237	230	224	213	213	205	140	-
7/8	2-014				10000	625	418	332	276	264	230	219	209	201	194	188	183	177	169	169	163	140	-
15/16	2-015	-	-		30000	625	290	230	191	183	160	152	145	139	135	130	127	123	117	117	113	107	-
25mm	5205				50000	527	245	194	161	154	135	128	122	118	114	110	107	104	99	99	95	90	-
1	2-1				100000	418	194	154	128	122	107	102	97	93	90	87	85	82	78	78	76	72	-
1 1/16	2-11	15/16	3-015	438	5000	1039	825	654	543	519	454	431	412	396	383	370	360	351	334	334	219	-	
1 1/8	2-12	1	3-1		10000	978	654	519	431	412	360	342	327	315	304	294	286	278	265	265	219	-	
1 3/16	2-13	25mm	5305		30000	978	454	360	299	286	250	237	227	218	211	204	198	193	184	184	176	-	
30mm	5206				50000	825	383	304	252	241	211	200	191	184	178	172	167	163	155	155	149	-	
1 1/4R	1-14				100000	654	304	241	200	191	167	159	152	146	141	136	133	129	123	123	118	-	
1 1/4	2-14	30mm	5306	5782	5000	1290	1088	864	717	686	599	569	544	523	505	489	475	463	290	-	-	-	
1 5/16	2-15	1 3/16	3-13		10000	1290	864	686	569	544	475	452	432	415	401	388	377	367	290	-	-		
1 3/8	2-16				30000	1290	599	475	394	377	330	313	299	288	278	269	262	255	243	-	-		
35mm	5207				50000	1088	505	401	333	318	278	264	253	243	234	227	221	215	205	-	-		
1 7/16	2-17				100000	864	401	318	264	253	221	210	200	193	186	180	175	171	163	-	-		
1 1/2	2-18	1 7/16	3-17	7340	5000	1638	1381	1096	910	870	760	722	691	664	641	621	603	365	-	-	-		
1 9/16	2-19	35mm	5307		10000	1638	1096	870	722	691	603	573	548	527	509	493	479	365	-	-			
40mm	5208				30000	1638	760	603	501	479	418	397	380	365	353	342	332	323	-	-			
					50000	1381	641	509	422	404	353	335	321	308	298	288	280	273	-	-			
					100000	1096	509	409	335	321	280	266	254	245	236	229	222	216	-	-			
1 5/8	2-110	1 1/2	3-18	7901	5000	1763	1487	1180	979	937	818	777	744	715	690	669	395	-	-	-			
1 11/16	2-111	45mm	5308		10000	1763	1180	937	777	744	650	617	590	567	548	531	395	-	-				
1 3/4	2-112				30000	1763	818	650	539	516	450	428	409	393	380	368	357	-	-				
45mm	5209				50000	1487	690	548	455	435	380	361	345	332	320	310	301	-	-				
					100000	1180	548	435	361	345	301	286	274	263	254	246	239	-	-				
1 13/16	2-113	1 11/16	3-111	7881	5000	1760	1485	1178	978	935	817	776	742	714	689	668	-	-	-				
1 7/8	2-114	1 3/4	3-112		10000	1760	1178	935	776	742	649	616	589	567	547	395	-	-					
1 15/16	2-115	45mm	5309		30000	1760	817	649	538	515	450	427	409	393	379	395	-	-					
50mm	5210				50000	1485	689	547	454	434	379	360	345	331	320	310	-	-					
	1-2				100000	1178	547	434	360	345	301	286	273	263	254	246	-	-					
2	2-2	1 15/16	3-115	9752	5000	2176	1835	1457	1209	1156	1010	959	918	882	480	-	-	-					
2 1/8	2-22	50mm	5310		10000	2176	1457	1156	959	918	802	762	728	700	480	-	-						
55mm	5211				30000	2176	1010	802	665	636	556	528	505	486	469	-	-						
2 3/16	2-23				50000	1835	852	676	561	537	469	445	426	410	395	-	-						
					100000	1457	676	537	445	426	372	353	338	325	314	-	-						
2 1/4	2-24	55mm	5311	11789	5000	2631	2219	1761	1461	1398	1221	1160	1109	590	-	-	-						
2 5/16	2-25	2 3/16	3-23		10000	2631	1761	1398	1160	1109	969	921	881	590	-	-							
60mm	5212				30000	2631	1221	969	804	769	672	638	611	587	-	-							
2 3/8	2-26				50000	2219	1030	817	678	649	567	538	515	495	-	-							
2 7/16	2-27				100000	1761	817	649	538	515	450	427	409	393	-	-							

## CUSTOM SELECT™... Availability

**Locking Options:** ● Set Screw ▲ SKWEZLOC Concentric ■ Double Lock



Shaft Size	Nomenclature Size	NP	NPL	SP	SFT	SF	SFC	TB	ST	FB
1/2"	8	●	●		●	●		●	●	●
9/16"	9									
5/8"	10	●▲	●▲		●▲	●▲		●▲	●▲	●▲
11/16"	11									
3/4"	12	●	●		●	●		●	●	●
20mm	204	●	●		●	●		●	●	●
7/8"	14	●	●	●	●	●		●	●	●
15/16"	15	●▲	●▲	●▲	●▲	●▲		●▲	●▲	●▲
1"	16	●▲■	●▲	●▲■	●▲	●▲		●▲	●▲	●▲
25mm	205	●	●	●	●	●		●	●	●
1 1/8"	18	●▲	●▲	●▲	●▲	●▲	●▲	●▲	●▲	●▲
1 3/16"	19	●▲■	●▲	●▲■	●▲	●▲	●▲	●▲	●▲	●▲
1 1/4"	20	●	●	●	●	●	●	●	●	●
30mm	206	●	●	●	●	●	●	●	●	●
1 1/4"	20	●▲	●▲	●▲	●▲	●▲	●▲	●▲	●▲	●▲
1 5/16"	21	●	●	●	●	●	●	●	●	●
1 3/8"	22	●▲	●▲	●▲	●▲	●▲	●▲	●▲	●▲	●▲
1 7/16"	23	●▲■	●▲	●▲■	●▲	●▲	●▲	●▲	●▲	●▲
35mm	207	●	●	●	●	●	●	●	●	●
1 1/2"	24	●▲■	●▲	●▲■	●▲	●▲	●▲	●▲	●▲	●▲
1 9/16"	25	●	●	●	●	●	●	●	●	●
40mm	208	●	●	●	●	●	●	●	●	●
1 5/8"	26	●▲	●▲	●▲	●▲	●▲	●▲	●▲	●▲	●
1 11/16"	27	●▲■	●▲	●▲■	●▲	●▲	●▲	●▲	●▲	●▲
1 3/4"	28	●▲	●▲	●▲	●▲	●▲	●▲	●▲	●▲	●
45mm	209	●	●	●	●	●	●	●	●	●
1 7/8"	30	●	●	●	●	●	●	●	●	●
1 15/16"	31	●▲■	●▲	●▲■	●▲	●▲	●▲	●▲	●▲	●▲
2"	32R	●▲	●▲	●▲	●▲	●▲	●▲	●	●▲	●
50mm	210	●	●	●	●	●	●	●	●	●
2"	32	●■	●	●	●	●	●	●	●	●
2 3/16"	35	●▲■	●▲	●▲■	●▲	●▲	●▲	●▲	●▲	●▲
2 1/4"	36	●▲	●▲	●▲		●▲	●▲		●▲	
2 7/16"	39	●▲■	●▲	●▲■		●▲	●▲		●▲	
Expansion Available*		Y	N	N	Y	Y	N	N	N	N
Dimensional Data BP-97 Page		20	21	24	26	28	29	23	32	27

■ 9 Days or Less □ Call for Availability

**For quantities over 25 pieces consult EPT Customer Service at (800) 626-2120**

\*Expansion units are available in the same bore sizes as the set screw offering

No expansion units available in bore sizes below 3/4"

Dimensional data available at [www.emerson-ept.com/SMcustom](http://www.emerson-ept.com/SMcustom) or in the Catalog BP-97

**CUSTOM SELECT™... Availability**



SC	MP	MSF	MFC	MSFT	Shaft Size	Nomenclature Size
●					1/2"	8
					9/16"	9
● ▲					5/8"	10
					11/16"	11
●					3/4"	12
●					20mm	204
●					7/8"	14
● ▲					15/16"	15
● ▲	● ▲	● ▲	● ▲	● ▲	1"	16
●	●	●	●	●	25mm	205
● ▲					1 1/8"	18
● ▲	● ▲ ■	● ▲	● ▲	● ▲	1 3/16"	19
●					1 1/4"	20
●	●	●	●	●	30mm	206
● ▲	● ▲	● ▲	● ▲	● ▲	1 1/4"	20
●					1 5/16"	21
● ▲					1 3/8"	22
● ▲	● ▲ ■	● ▲	● ▲	● ▲	1 7/16"	23
●	●	●	●	●	35mm	207
● ▲	● ▲ ■	● ▲	● ▲	● ▲	1 1/2"	24
●					1 9/16"	25
●	●	●	●	●	40mm	208
● ▲					1 5/8"	26
● ▲	● ▲ ■	● ▲	● ▲	● ▲	1 11/16"	27
● ▲	●	●	●	●	1 3/4"	28
●	●	●	●	●	45mm	209
●					1 7/8"	30
● ▲	● ▲ ■	● ▲	● ▲	● ▲	1 15/16"	31
● ▲					2"	32R
●	●	●	●	●	50mm	210
●	■				2"	32
● ▲	● ▲ ■	● ▲	● ▲		2 3/16"	35
● ▲					2 1/4"	36
● ▲					2 7/16"	39
N	Y	Y	N	N	Expansion Available*	
33	47	55	56	54	Dimensional Data BP-97 Page	

For ERX ER Bearings See ERX-98 Catalog

**Online  
CUSTOM SELECT™  
Selector Program**

Visit

[www.emerson-ept.com/SMcustom](http://www.emerson-ept.com/SMcustom)

for a comprehensive web program that allows you to enter your application information to determine the correct CUSTOM SELECT™ Bearing for your needs. This program includes:

- Bearing Selection
- Lubrication Requirements
- Engineering Information
- Links to CAD drawings

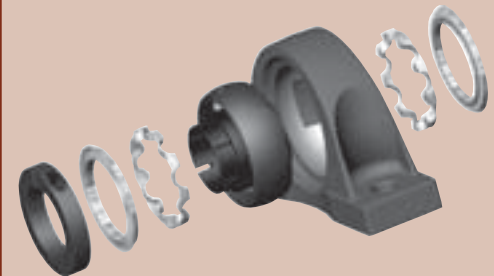

[www.emerson-ept.com/SMcustom](http://www.emerson-ept.com/SMcustom)

SHAFT TOLERANCES FOR BALL BEARINGS	
Shaft Diameter (in.)	Shaft Tolerance (in.)
1/2 - 1 15/16	Plus .0000 to minus .0005
2 - 3 3/16	Plus .0000 to minus .0010
3 1/4 - 4 15/16	Plus .0000 to minus .0015

## *CUSTOM SELECT™...*

### **Ready To Ship In 9 Days Or Less \***

#### **Lean Manufacturing Principles**

In addition to our business focus on customer satisfaction, a primary goal for EPT Bearings is our Lean Manufacturing program which has helped position us to supply custom products, competitively priced, with short lead times, on demand!

- **Single Piece Lot Size Capabilities**

Using the Lean concepts of rapid changeovers, flexible equipment, and speed, we are now able to effectively process orders as small as single piece lot sizes. No more minimum order requirements for ATO products.

- **Kan-Ban Pull Process**

Process ensures that we have the proper components available to assemble the end product on demand. The pull system also automates our scheduling such that we only replenish the parts that we actually use, not those that we hope to someday use.

- **Flexible Assemble To Order (ATO) Process**

Strategic placement of component level inventories allows us to use our flexible assembly process to supply bearings with different housings, inner races, outer races, greases, locking mechanisms, retainers, and seals when you want them.

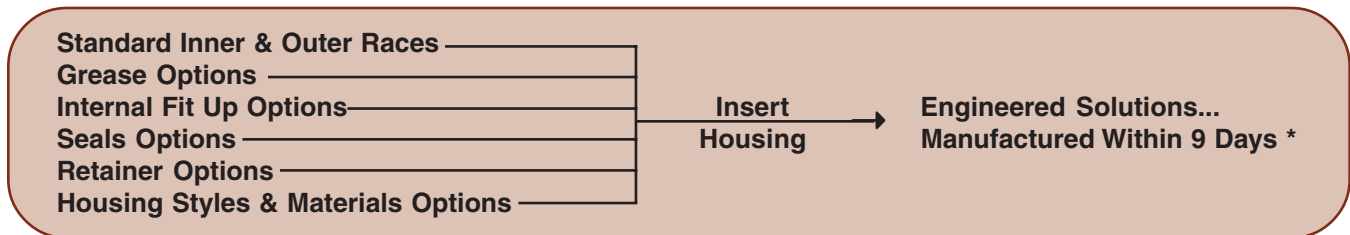

- **Flexible Component Replenishment System**

This system goes all the way back in the supply chain to our raw materials to ensure that as components are used in our final product assemblies, we have the processes in place to rapidly replenish the parts for future requirements. Many Lean Manufacturing processes have been utilized in this process including mixed model scheduling, cellular manufacturing, demand flow, and queue management.

## **Delivery Options**

When your product is ready to ship from our plant you will have a choice of multiple delivery options. Keeping in mind that next day direct factory shipments are always available, we urge you to contact an EPT Customer Service Representative to determine the best option for your delivery needs. Standard EPT freight terms apply.

\* For quantities over 25 pieces consult EPT Customer Service at (800) 626-2120.

All sales are made on our STANDARD TERMS AND CONDITIONS OF SALE in effect at the time a customer's order is accepted. The current Terms and Conditions are set forth below:

## STANDARD TERMS AND CONDITIONS OF SALE (August 15, 2001)

These Terms and Conditions, the attendant quotation or acknowledgment and all documents incorporated by specific reference therein, will be the complete and exclusive statement of the terms of the agreement governing the sale of goods ("Goods") by **Emerson Power Transmission Corporation** and its divisions and subsidiaries ("Seller") to Customer ("Buyer"). Buyer's acceptance of the Goods will manifest Buyer's assent to these Terms and Conditions. If these Terms and Conditions differ in any way from the terms and conditions of Buyer's order, or other documentation, this document will be construed as a counteroffer and will not be deemed an acceptance of Buyer's terms and conditions which conflict herewith.

1. **PRICES:** Unless otherwise specified in writing by Seller, Seller's price for the goods shall remain in effect for thirty (30) days after the date of Seller's quotation or acknowledgment of Buyer's order for the Goods, whichever occurs first, provided an unconditional, complete authorization for the immediate shipment of the Goods is received and accepted by Seller within such time period. If such authorization is not received by Seller within thirty (30) day period, Seller shall have the right to change the price for the Good to Seller's price for the Goods at the time of shipment.

2. **TAXES:** Any tax or governmental charge or increase in same hereafter becoming effective increasing the cost to Seller of producing, selling or delivering the Goods or of procuring material used therein, and any tax now in effect or increase in same payable by the Seller because of the manufacture, sale or delivery of the Goods, may at Seller's option, be added to the price.

3. **TERMS OF PAYMENT:** Subject to the approval of Seller's Credit Department, terms are net thirty (30) days from date of Seller's invoice in U.S. currency. If any payment owed to Seller is not paid when due, it shall bear interest, at a rate to be determined by Seller, which shall not exceed the maximum rate permitted by law, from the date on which it is due until it is paid. Seller shall have the right, among other remedies, either to terminate the Agreement or to suspend further performance under this and/or other agreements with Buyer in the event Buyer fails to make any payment when due. Buyer shall be liable for all expenses, including attorneys' fees, relating to the collection of past due amounts.

4. **SHIPMENT AND DELIVERY:** Shipments are made F.O.B. Seller's shipping point. Any claims for shortages or damages suffered in transit shall be submitted by the Buyer directly to the carrier. While Seller will use all reasonable commercial efforts to maintain the delivery date acknowledged or quoted by Seller, all shipping dates are approximate. Seller reserves the right to make partial shipments and to segregate "specials" and made-to-order Goods from normal stock Goods. Seller shall not be bound to tender delivery of any Goods for which Buyer has not provided shipping instructions.

5. **QUANTITY:** Buyer agrees to accept overruns of up to ten percent (10%) of the order on "made-to-order" Goods, including parts. Any such additional items shall be priced at the price per item charged for the specific quantity ordered.

6. **LIMITED WARRANTY:** Subject to the limitations of Section 7, Seller warrants that the Goods will be free from defects in material and workmanship under normal use, service and maintenance for a period of one year (unless otherwise specified by Seller in writing) from the date of shipment of the Goods by Seller. **THIS IS THE SOLE AND EXCLUSIVE WARRANTY GIVEN BY SELLER WITH RESPECT TO THE GOODS AND IS IN LIEU OF AND EXCLUDES ALL OTHER WARRANTIES, EXPRESS OR IMPLIED, ARISING BY OPERATION OF LAW OR OTHERWISE, INCLUDING WITHOUT LIMITATION, MERCHANTABILITY OR FITNESS FOR A PARTICULAR PURPOSE WHETHER OR NOT THE PURPOSE OR USE HAS BEEN DISCLOSED TO SELLER IN SPECIFICATIONS, DRAWINGS OR OTHERWISE, AND WHETHER OR NOT SELLER'S PRODUCTS ARE SPECIFICALLY DESIGNED AND/OR MANUFACTURED BY SELLER FOR BUYER'S USE OR PURPOSE.**

This warranty does not extend to any losses or damages due to misuse, accident, abuse, neglect, normal wear and tear, unauthorized modification or alteration, use beyond rated capacity, or improper installation, maintenance or application. To the extent that Buyer or its agents has supplied specifications, information, representation of operating conditions or other data to Seller in the selection or design of the Goods and the preparation of Seller's quotation, and in the event that actual operating conditions or other conditions differ from those represented by Buyer, any warranties or other provisions contained herein which are affected by such conditions shall be null and void. If within thirty (30) days after Buyer's discovery of any warranty defects within the warranty period, Buyer notifies Seller thereof in writing, Seller shall, at its option, repair or replace F.O.B. point of manufacture, or refund the purchase price for, that portion of the goods found by Seller to be defective. Failure by Buyer to give such written notice within the applicable time period shall be deemed an absolute and unconditional waiver of Buyer's claim for such defects. Goods repaired or replaced during the warranty period shall be covered by the foregoing warranty for the remainder of the original warranty period or ninety (90) days, whichever is longer. Buyer assumes all other responsibility for any loss, damage, or injury to persons or property arising out of, connected with, or resulting from the use of Goods, either alone or in combination with other products/components.

**SECTIONS 6 AND 7 APPLY TO ANY ENTITY OR PERSON WHO MAY BUY, ACQUIRE OR USE SELLER'S GOODS, INCLUDING ANY ENTITY OR PERSON WHO BUYS THE GOODS FROM SELLER'S DISTRIBUTOR AND SUCH ENTITY OR PERSON SHALL BE BOUND BY THE LIMITATIONS THEREIN.**

7. **LIMITATION OF REMEDY AND LIABILITY: THE SOLE AND EXCLUSIVE REMEDY FOR BREACH OF ANY WARRANTY HEREUNDER (OTHER THAN THE WARRANTY PROVIDED UNDER SECTION 13) SHALL BE LIMITED TO REPAIR, REPLACEMENT OR REFUND OF THE PURCHASE PRICE UNDER SECTION 6. SELLER SHALL NOT BE LIABLE FOR DAMAGES CAUSED BY DELAY IN PERFORMANCE AND IN NO EVENT, REGARDLESS OF THE FORM OF THE CLAIM OR CAUSE OF ACTION (WHETHER BASED IN CONTRACT, INFRINGEMENT, NEGLIGENCE, STRICT LIABILITY, OTHER TORT OR OTHERWISE), SHALL SELLER'S LIABILITY TO BUYER AND/OR ITS CUSTOMERS EXCEED THE PRICE TO BUYER OF THE SPECIFIC GOODS PROVIDED BY SELLER GIVING RISE TO THE CLAIM OR CAUSE OF ACTION. BUYER AGREES THAT IN NO EVENT SHALL SELLER'S LIABILITY TO BUYER AND/OR ITS CUSTOMERS EXTEND TO INCLUDE INCIDENTAL, CONSEQUENTIAL OR PUNITIVE DAMAGES. THE TERM "CONSEQUENTIAL DAMAGES" SHALL INCLUDE, BUT NOT BE LIMITED TO, LOSS OF ANTICIPATED PROFITS, LOSS OF USE, LOSS OF REVENUE, COST OF CAPITAL AND DAMAGE OR LOSS OF OTHER PROPERTY OR EQUIPMENT.**

It is expressly understood that any technical advice furnished by Seller with respect to the use of the Goods is given without charge, and Seller assumes no obligation or liability for the advice given, or results obtained, all such advice being given and accepted at Buyer's risk.

**GOODS AND/OR SERVICES SOLD HEREUNDER ARE NOT FOR USE IN ANY NUCLEAR AND RELATED APPLICATIONS.** Buyer accepts goods and/or services with the foregoing understanding, agrees to communicate the same in writing to any subsequent purchaser or users and to defend, indemnify and hold harmless Seller from any claims, losses, suits, judgments and damages, including incidental and consequential damages, arising from such use, whether the cause of action be based in tort, contract or otherwise, including allegations that the Seller's liability is based on negligence or strict liability.

8. **EXCUSE OF PERFORMANCE:** Seller shall not be liable for delays in performance or for non-performance due to acts of God, acts of Buyer, war, riot, fire, flood, other severe weather, sabotage, or epidemics; strikes or labor disturbances; governmental requests, restrictions, laws, regulations, orders or actions; unavailability of or delays in transportation; default of suppliers; or unforeseen circumstances or any events or causes beyond Seller's reasonable control. Deliveries may be suspended for an appropriate period of time as a result of the foregoing. If Seller determines that its ability to supply the total demand for the Goods, or to obtain material used directly or indirectly in the manufacture of the Goods, is hindered, limited or made impracticable due to causes addressed in this Section 8, Seller may allocate its available supply of the Goods or such material (without obligation to acquire other supplies of any such Goods or material) among itself and its purchasers on such basis as Seller determines to be equitable without liability for any failure of performance which may result therefrom. Deliveries suspended or not made by reason of this section may be canceled by Seller upon notice to Buyer without liability, but the balance of the agreement shall otherwise remain unaffected.

9. **CANCELLATION:** The Buyer may cancel orders only upon written notice and upon payment to Seller of cancellation charges which include, among other things, all costs and expenses incurred and commitments made by the Seller and a reasonable profit thereon.

10. **CHANGES:** Buyer may request changes or additions to the Goods consistent with Seller's specifications and criteria. In the event such changes or additions are accepted by Seller, Seller may revise the price and delivery schedule. Seller reserves the right to change designs and specifications for the Goods without prior notice to Buyer, except with respect to Goods being made-to-order for Buyer.

11. **TOOLING:** Tool, die, and pattern charges, if any, are in addition to the price of the Goods and are due and payable upon completion of the tooling. All such tools, dies and patterns shall be and remain the property of Seller. Charges for tools, dies, and patterns do not convey to Buyer, title, ownership interests in, or rights to possession or removal, nor prevent their use by Seller for other purchasers, except as otherwise expressly provided by Seller and Buyer in writing with reference to this provision.

12. **ASSIGNMENT:** Buyer shall not assign its rights or delegate its duties hereunder or any interest therein or any rights hereunder without the prior written consent of the Seller, and any such assignment, without such consent, shall be void.

13. **PATENTS AND COPYRIGHTS:** Subject to Section 7, Seller warrants that the Goods sold, except as are made specifically for Buyer according to Buyer's specifications, do not infringe any valid U.S. patent or copyright in existence as of the date of delivery. This warranty is given upon the condition that Buyer promptly notify Seller of any claim or suit involving Buyer in which such infringement is alleged, and that Buyer cooperate fully with Seller and permit Seller to control completely the defense or compromise of any such allegation of infringement. Seller's warranty as to use only applies to infringements arising solely out of the inherent operation (i) of such Goods, or (ii) of any combination of Goods in a system designed by Seller. In the event such Goods, singularly or in combination, are held to infringe a U.S. patent or copyright in such suit, and the use of such Goods is enjoined, or in the case of a compromise by Seller, Seller shall have the right, at its option and expense, to procure for Buyer the right to continue using such Goods, or replace them with non-infringing Goods; or modify same to become non-infringing; or grant Buyer a credit for the depreciated value of such Goods and accept return of them.

14. **MISCELLANEOUS:** These terms and conditions set forth the entire understanding and agreement between Seller and Buyer, and supersede all other communications, negotiations and prior oral or written statements regarding the subject matter of these terms and conditions. No change, modification, rescission, discharge, abandonment, or waiver of these terms and conditions of Sale shall be binding upon the Seller unless made in writing and signed on its behalf by an officer of the Seller. No conditions, usage or trade, course of dealing or performance, understanding or agreement purporting to modify, vary, explain, or supplement these Terms and Conditions shall be binding unless hereafter made in writing and signed by the party to be bound, and no modification shall be affected by the acceptance of purchase orders or shipping instruction forms containing terms at variance with or in addition to those set forth herein. Any such modifications or additional terms are specifically rejected by Seller. No waiver by Seller with respect to any breach or default or any right or remedy and no course of dealing, shall be deemed to constitute a continuing waiver of any other breach or default or of any other right or remedy, unless such waiver be expressed in writing and signed by the party to be bound. Seller is not responsible for typographical or clerical errors made in any quotation, orders or publications. All such errors are subject to correction. The validity, performance, and all other matters relating to the interpretation and effect of this contract shall be governed by the law of the state of New York. The United Nations Convention on the International Sale of Goods shall not apply to any transaction hereunder.

# SEALMASTER

PERFORMANCE WITHOUT COMPROMISE

DESIGN

DEVELOP

DELIVER

SEALMASTER brand bearings offers unique features tailored to your application needs:

- Custom-assembled solutions ready to ship in nine days or less
- A family of specially formulated lubricants to maximize running performance
- An assortment of seals for protection in a variety of environments

A family of bearing solutions available when you need them so you won't have to compromise.



[www.emerson-ept.com](http://www.emerson-ept.com)

Connect here to experience "the power of EPT"

**EMERSON POWER TRANSMISSION**  
620 S. Aurora Street • Ithaca, New York

For additional information contact:

Application Engineering & Mounted Bearing Technical Services - (630) 898-9620

Emerson Power Transmission Customer Service - (800) 626-2120

#### APPLICATION CONSIDERATIONS

The proper selection and application of power transmission products and components, including the related area of product safety, is the responsibility of the customer. Operating and performance requirements and potential associated issues will vary appreciably depending upon the use and application of such products and components. The scope of the technical and application information included in this publication is necessarily limited. Unusual operating environments and conditions, lubrication requirements, loading supports, and other factors can materially affect the application and operating results of the products and components and the customer should carefully review its requirements. Any technical advice or review furnished by Emerson Power Transmission Corporation and its divisions with respect to the use of products and components is given in good faith and without charge, and Emerson assumes no obligation or liability for the advice given, or results obtained, all such advice and review being given and accepted at customer's risk.

For a copy of our Standard Terms and Conditions of Sale, Disclaimers of Warranty, Limitation of Liability and Remedy, please contact EPT Customer Service at 1-800-626-2120. These terms and conditions of sale, disclaimers and limitations of liability apply to any person who may buy, acquire or use an Emerson Power Transmission Corporation product referred to herein, including any person who buys from a licensed distributor of these branded products.

Circle 3535-02  
Form 02/00 2/02-3535  
Printed in U.S.A.