

# Modular Tilting Pad Thrust Bearings

DHB 5A MS range

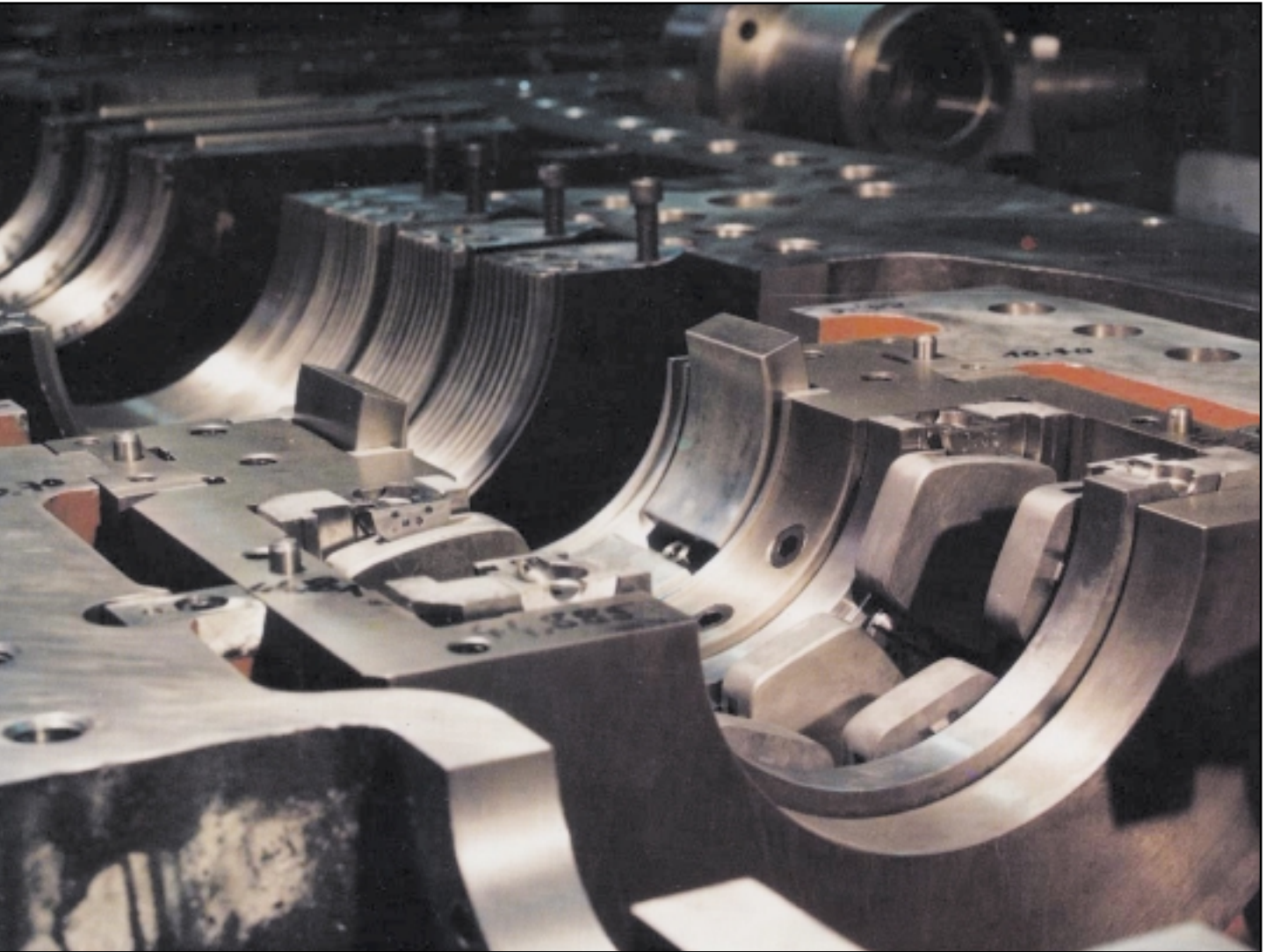



Front and inside cover photos show clearly the two lubrication systems available with WBC thrust bearings.

Front cover: 20 MW Naval gearbox fitted with Series 11 flooded lubrication MS standard bearings for medium speed duties.  
Photo: Maag Gear Wheel Company Ltd. Zurich, Switzerland.

Inside cover: 15 MW steam turbine using Series 8 Directed Lubrication MS bearings saving power loss at higher speeds and eliminating the need for pressurised bearing housing seals.  
Photo: Framatome Division Creusot-Energie, Le Creusot, France.

# Contents

<b>1</b>	<b>Product Summary</b>	<b>4</b>
<b>2</b>	<b>General Description</b>	<b>5</b>
	Pads	5
	Carrier rings	5
	Pad retention	5
	Screw threads	6
	Adjusting spacers	6
<b>3</b>	<b>Lubrication Systems</b>	<b>7</b>
	Flooded lubrication	7
	Directed lubrication	7
<b>4</b>	<b>Power Loss and Oil Flow</b>	<b>9</b>
<b>5</b>	<b>Alternative Pad Materials &amp; Design</b>	<b>9</b>
	Material	10
	Offset pivots	12
<b>6</b>	<b>Instrumentation</b>	<b>12</b>
	Temperature and proximity sensors	12
	Thrust load measurement	13
<b>7</b>	<b>Hydrostatic jacking</b>	<b>15</b>
<b>8</b>	<b>Reference Codes</b>	<b>16</b>
<b>9</b>	<b>Bearing Selection</b>	<b>17</b>
<b>10</b>	<b>Size Tables</b>	<b>19</b>
	Series 6	20
	Series 8	22
	Series 11	24
	Series 14	26
	Series 18	28
	Series 7 large	30
	Series 8 large	31
	Series 9 large	32
	Series 10 large	33
	Series 11 large	34
	Series 12 large	35
<b>11</b>	<b>Other Bearing Products</b>	<b>36</b>
<b>12</b>	<b>Email/Fax Service for Performance Prediction</b>	<b>37</b>

## Benefits of MS Thrust Bearings

- **Flexibility and Compactness**
  - with over 200 standard sizes to choose from there is an MS bearing to fit all likely combinations of load, speed and shaft size
- **WBC Directed Lubrication**
  - available in all sizes - offering
  - significantly reduced power loss, often over 50% at higher speeds
  - lower oil flows at high speeds, lower bearing surface temperatures and increased oil film thickness
  - savings in overall capital cost and higher plant efficiency
  - simpler installation - no shaft seals needed
  - proven success over 40 years
- **Access to New Materials and Technology**
  - the MS range specifically allows for continual development: in particular new thrust pad materials extend speed, load and temperature limits - all in the same space
- **Worldwide Reputation and Experience**
  - built up through working closely with international leaders in their fields on the latest developments in rotating plant, especially in the 1 to 300 MW power range
- **Simplified Stocks and Minimum Inventory**
  - standard pads are centre pivoted
  - use of 1 pad size in a variety of ring configurations reduces number of different pads in use
  - replacement pads available quickly
- **Effective Design**
  - small and medium size rings handled as units (no loose pads)
  - pads all equally spaced and free to tilt (no risk of pads jamming in groove)
  - pad shape gives low frictional drag and improved oil circulation
  - number of pads fitted to thrust ring can be varied to suit load

WBC Tilting Pad Thrust Bearings are designed to transfer high axial loads from rotating shafts with minimum power loss, while simplifying installation and maintenance. The shaft diameters for which the bearings are designed range from 20mm to over 1000mm. The maximum loads for the various bearing types range from 0.5 to 500 tonne. Bearings of larger size and load capacity can be made to special order.

Each bearing consists of a series of pads supported in a carrier ring; each pad is free to tilt so as to create a self-sustaining hydrodynamic film. The carrier ring may be in one piece or in halves, and there are various location arrangements.

Two options exist for lubrication. One is by fully flooding the bearing housing, the other, which is more suitable for higher speed applications, directs oil to the thrust face; this oil is then allowed to drain freely from the bearing housing.

See also our CQ range of compact equalised tilting pad thrust bearings.

# 2

## General Description

The MS range was designed to operate without equalising levers, and has been successfully used by most turbo machinery manufacturers in Western Europe to become what is generally regarded as the standard thrust bearing system.

### Pads

The patented thrust pad profile is designed to minimise power loss while maintaining load carrying capacity. In its standard form the pad is made of steel faced with tin based whitmetal, while pivoting each pad in the centre makes the bearing suitable for rotation in either direction. Thrust pads with alternative facing and backing materials as well as offset pivots can be supplied for special applications. (See section 5)

### Carrier Rings

The carrier rings may be either in one piece or two to permit assembly around the shaft without removing the thrust collar. An anti-rotation stop pin (or key) is fitted either on the back of the carrier ring or on the edge (see Size Tables). Depending on the design of the housing, slots can be provided at the back of the carrier ring to facilitate oil flow to the bearing. (See Fig 11)

### Pad Retention

For small and medium size thrust rings (up to pad size 538) the pads are loosely held in the carrier ring by means of pad stops and a retaining lip. This construction, which is shown in Fig 1, enables complete rings or half rings to be handled with no risk of components falling out.

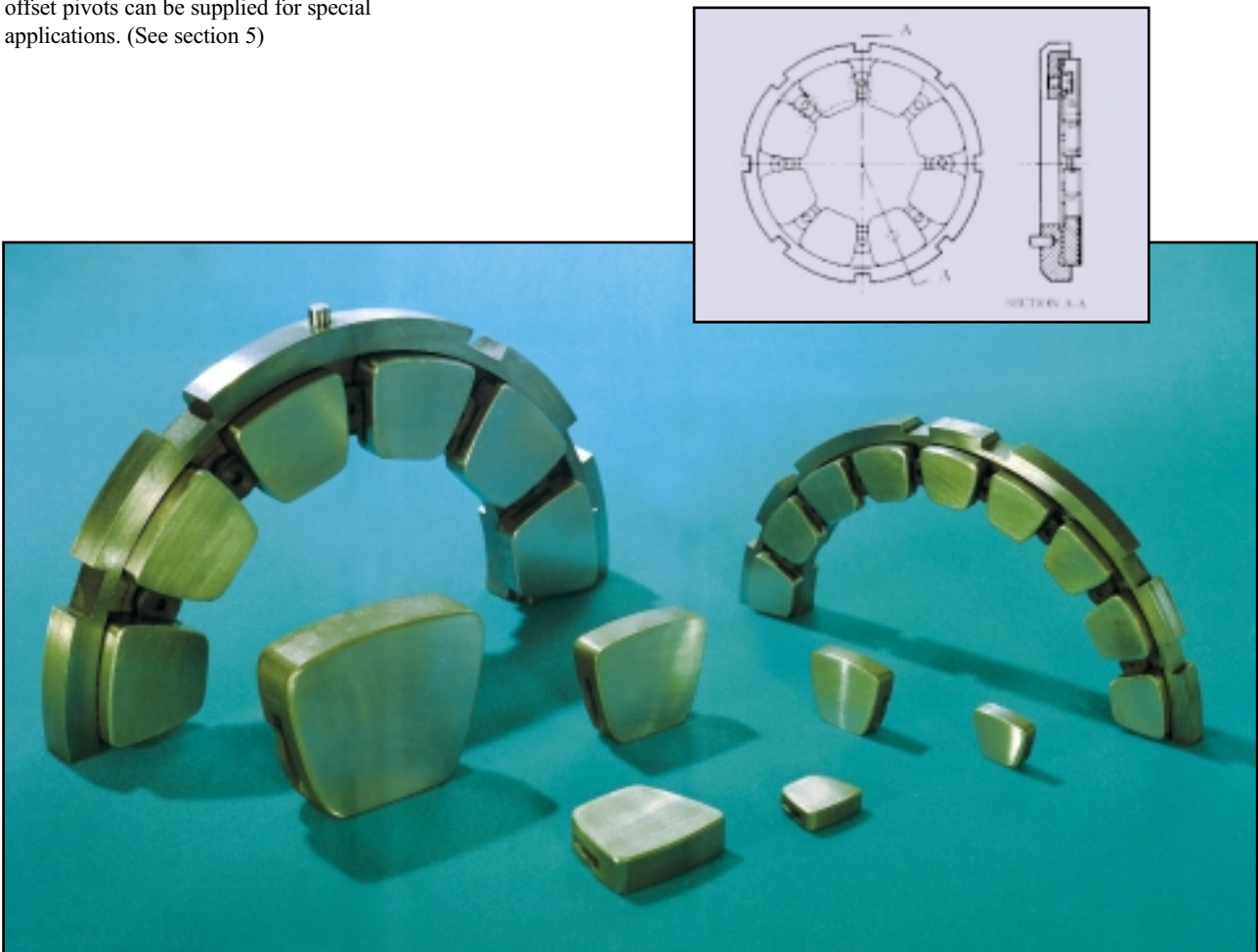

Fig 1. Standard MS Series thrust bearings in halves, and (inset) Series 8 one piece thrust bearing.



## General Description

Continued

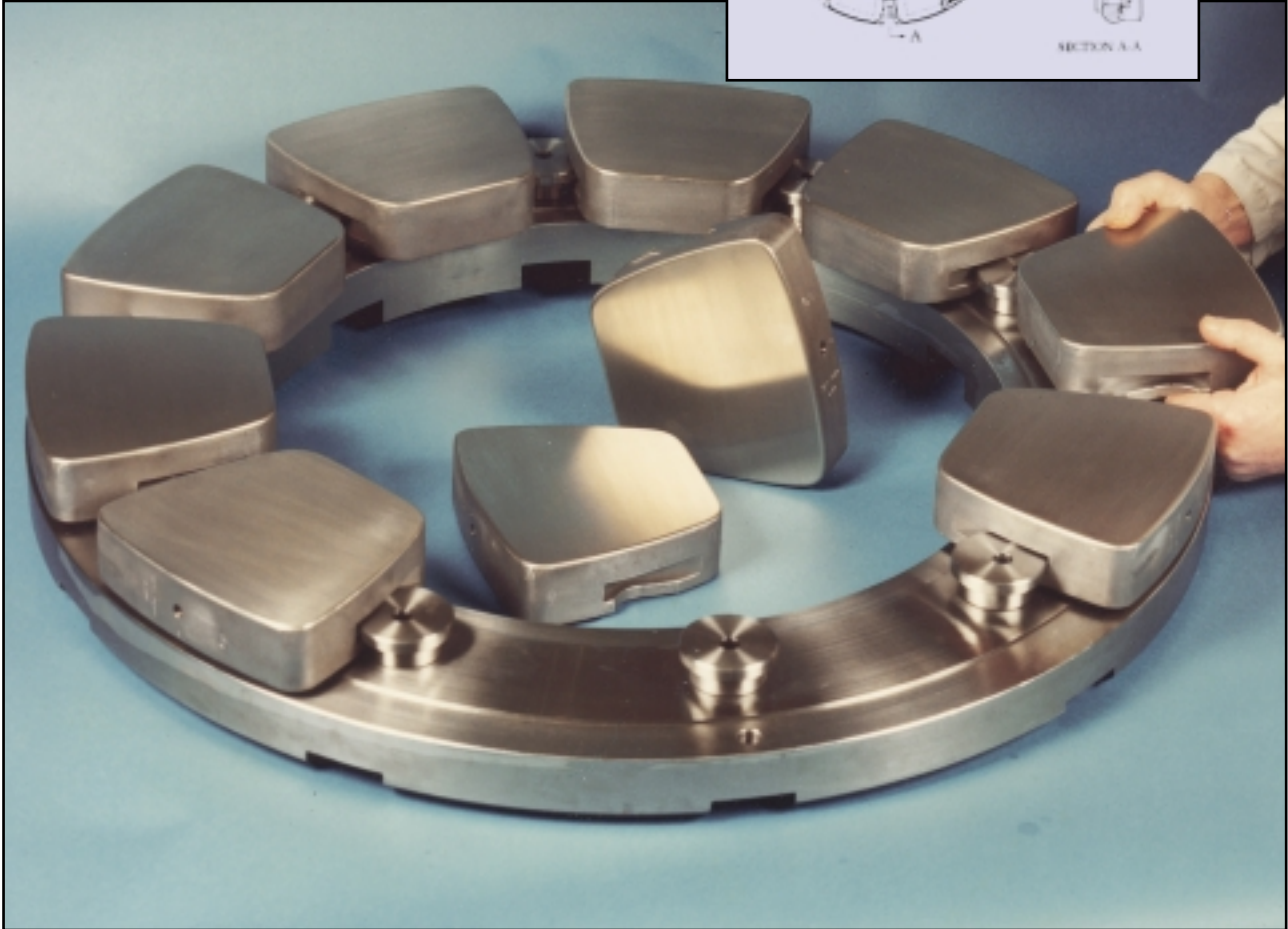
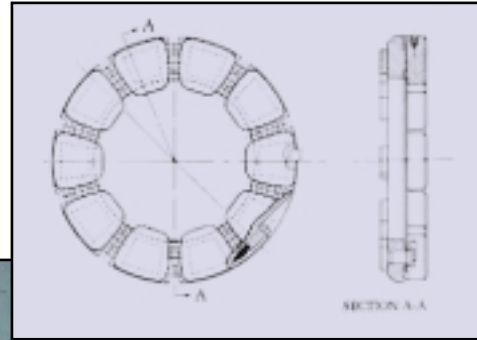

Fig. 2. Large 10 series thrust bearing showing lipless carrier ring.

For the largest thrust rings, pads are usually assembled individually in a lipless carrier ring, with radial retention being provided by the machine housing as shown in Fig 2.

Pad stops are screwed into position on thrust rings incorporating a retaining lip. In bearings with a lipless construction, the pad stops are permanently fastened in the carrier ring except where vertical shaft applications require pads to be removed vertically.

### Screw Threads

MS thrust rings are normally supplied with the threaded components to ISO metric standards.

### Adjusting Spacers

While a plain thrust ring is suitable for many installations, it does not allow adjustment of the axial clearance or of the shaft position. Where adjustment is required, spacer rings (or segments) can be provided which are secured to the back of the carrier ring by screws. Two types of spacer can be supplied:

- 1. Solid spacer.** This is of steel and can be supplied in two styles:
  - With machining allowance - in this style a machining allowance is provided at the back to enable correct clearances to be set at machine assembly. Spacers are supplied to the thickness N2 given in the size tables and may be machined to the minimum thickness N1.

- Finished to size - in this style the overall ring thickness ('C' + 'N1' dimensions) will be supplied within specified limits: for thrust rings with pad sizes up to 538 the tolerance is +0 -0.025mm.

- 2. Shimmed spacer.** In this case the solid spacer as described above is used with additional shims secured between the spacer and the carrier ring. The standard complement of shims is one at 0.25mm thick, and two at 0.125mm; while this is adequate for most applications, additional shims may be ordered if required.

When ordering, the correct code for the type of spacer required as given in Section 8 should be stated.

# 3

## Lubrication Systems

### Flooded Lubrication

The conventional method of lubricating tilting pad thrust bearings is to flood the housing with oil, using an orifice on the outlet to regulate the flow and maintain pressure. A typical double thrust bearing of this type is illustrated in Fig 3. A housing pressure of 0.7 - 1.0 bar is usual and, to minimise leakage, seal rings are required where the shaft passes through the housing. WBC can supply floating seals.

Various other arrangements can be used, and we will be pleased to comment on receipt of details.

### Directed Lubrication

Although flooded lubrication is simple, it results in high parasitic power loss due to turbulence at high speed. Where mean sliding speeds in excess of 50 m/s are expected, these losses may be largely eliminated by employing our system of Directed Lubrication. As well as reducing power loss by (typically) 50%, Directed Lubrication also reduces the bearing temperature and in most cases oil flow. Some typical double thrust bearing arrangements using Directed Lubrication are shown in Fig 4 and photographs of typical thrust rings can be seen on pages 8 and 19.

The following design points should be noted:

- Directed and flooded bearings have the same basic sizes, and use identical thrust pads.
- Preferred oil supply pressure for directed lubrication is 1.4 bar.
- Oil velocity in the supply passages should not exceed 3 m/s to ensure full pressure at the bearing.
- The bearing housing must be kept free of bulk oil by ample drain area around the collar periphery. Consult WBC where drain velocities exceeding those in Fig 4 are expected.
- No seal rings are required on the shaft.

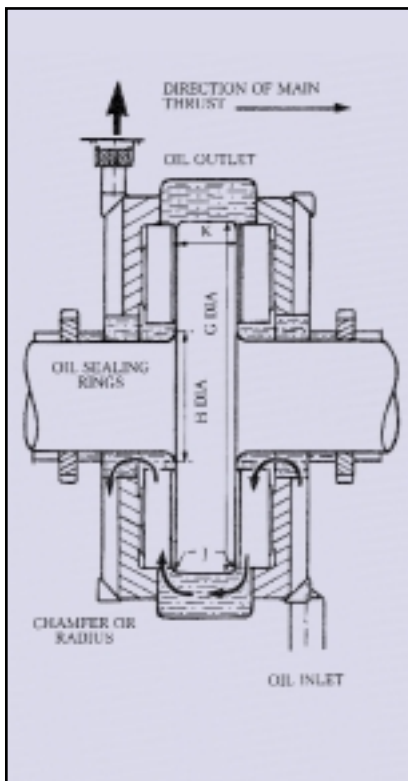

Fig 3.

Flooded Lubrication: typical double thrust arrangement

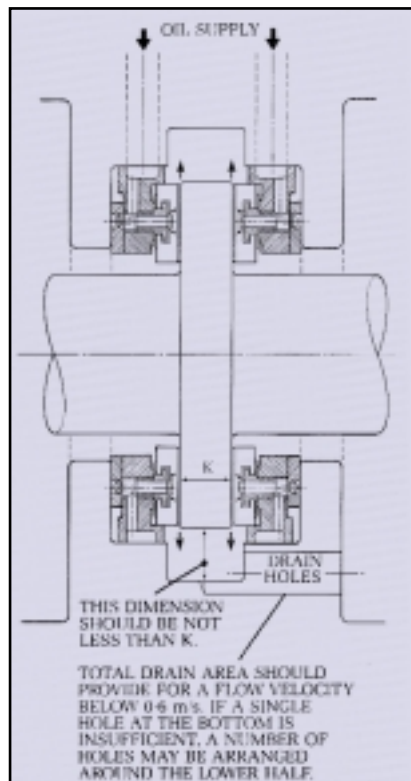

Fig 4a.

Directed Lubrication: typical double thrust arrangements designed to prevent bulk oil from contacting the collar.

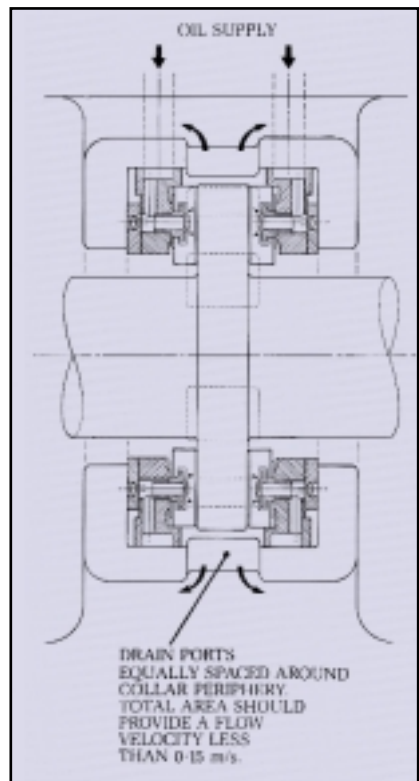
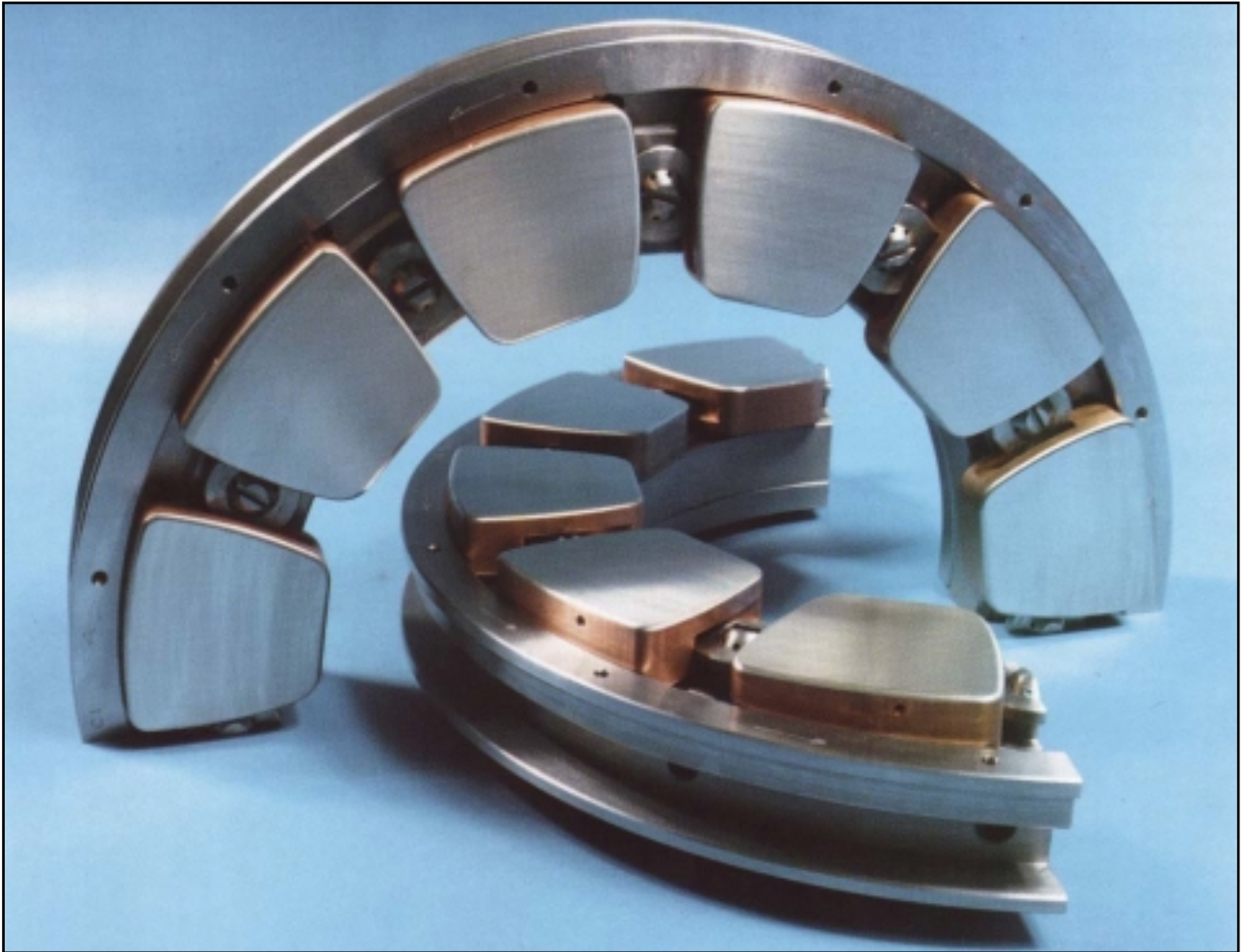

Fig 4b.

## Lubrication Systems

Continued



M11246/2P(DL) Directed Lubrication thrust ring for marine gas turbine.



# 4

## Power Loss and Oil Flow

The power loss in a bearing results from the combination of viscous shear in the oil film and (in flooded bearings) of turbulence in the oil caused by the rotation of the shaft in an oil filled housing. This power loss appears as heat, and this must be removed from the bearing by the flow of lubricant. Computer programs exist to give accurate estimates of power loss and the oil flow required. WBC can assist in this, and the Email/Fax service set out on page 37 may be used for this purpose if desired.

# 5

## Alternative Pad Materials and Design

High operating speeds and loads, and high oil inlet temperatures increasingly take bearing design beyond the limits of whitmetal lined centre pivoted thrust pads. Heat soak at standstill is also a factor.

WBC offer the widest choice of materials where applications exceed the selection parameters referred to in Section 9, or lubricants other than oil are envisaged. RPB25P Polymer especially offers outstanding potential for high temperature/load and water lubricated cases, as well as being a good insulator and resistant to chemical attack.

Major material combinations to cater for high pad temperatures are illustrated on the next two pages.



RPB25P is a material development from our Research Laboratories: the MS range series 6 bearing shown here has been fitted with RPB25P pads for a high temperature, high load application in North America.

# Alternative Pad Materials and Design

Continued

**Pad Surface Material**  
40% tin aluminium.

**Pad Backing Material**  
Steel

**Remarks**  
Operates up to 25°C higher than whitemetal with comparable embeddability and superior corrosion resistance.

**Pad Surface Material**  
Copper Lead

**Pad Backing Material**  
Steel

**Remarks**  
Operates up to 40°C higher than whitemetal. Requires hardened thrust collar.

**Pad Surface Material**  
RPB 25P Polymer

**Pad Backing Material**  
Steel

**Remarks**  
Operates up to 120°C higher than whitemetal. Resistant to chemical attack and a good insulator.

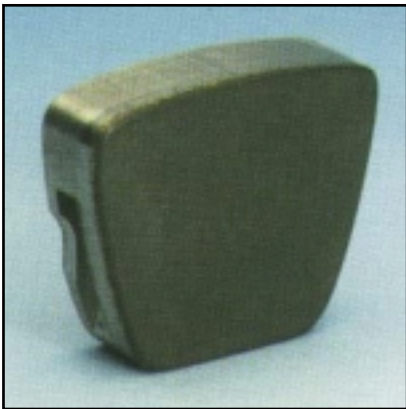

# Alternative Pad Materials and Design

Continued

**Pad Surface Material**  
GM130S Tin based whitemetal

**Pad Backing Material**  
Copper chromium

**Remarks**  
Reduces pad temperatures by  
20-25°C



Special Assemblies with copper lead lined Thrust (and Journal) Pads designed to run at up to 60 000 rev/min for NASA application.

## Alternative Pad Materials and Design

Continued

### Pivot Position

All pads can be supplied with offset pivots, but centre pivoted pads are preferred for bi-directional running, foolproof assembly and minimum stocks. At moderate speeds the pivot position does not affect load capacity but where mean sliding speeds exceed 70 m/s offset pivots can reduce bearing surface temperatures and thus increase load capacity under running conditions (see Fig 5).

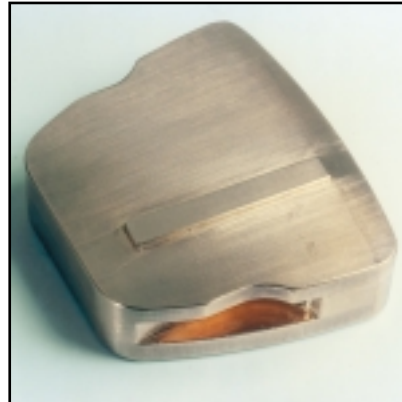

Offset pivot thrust pad.

### Temperature and proximity sensors

WBC thrust bearings can be supplied to take temperature sensors and proximity probes (for detecting bearing malfunction) to suit most requirements:-

#### 1 Temperature sensors

When ordering these, the following information is required:

- Position and number of sensors
- Type (thermocouple or RTD)
- Whether or not sheath earthing or insulation is required
- Sensor materials
- Lead material
- Lead length and termination

A typical installation of temperature sensors in an 8 Series thrust ring is shown in Fig 6.

#### 2 Proximity probes

These can be fitted in the larger sizes of bearing without changing the dimensions of the ring or collar. Two alternative methods of fitting these probes are shown in Fig 7.

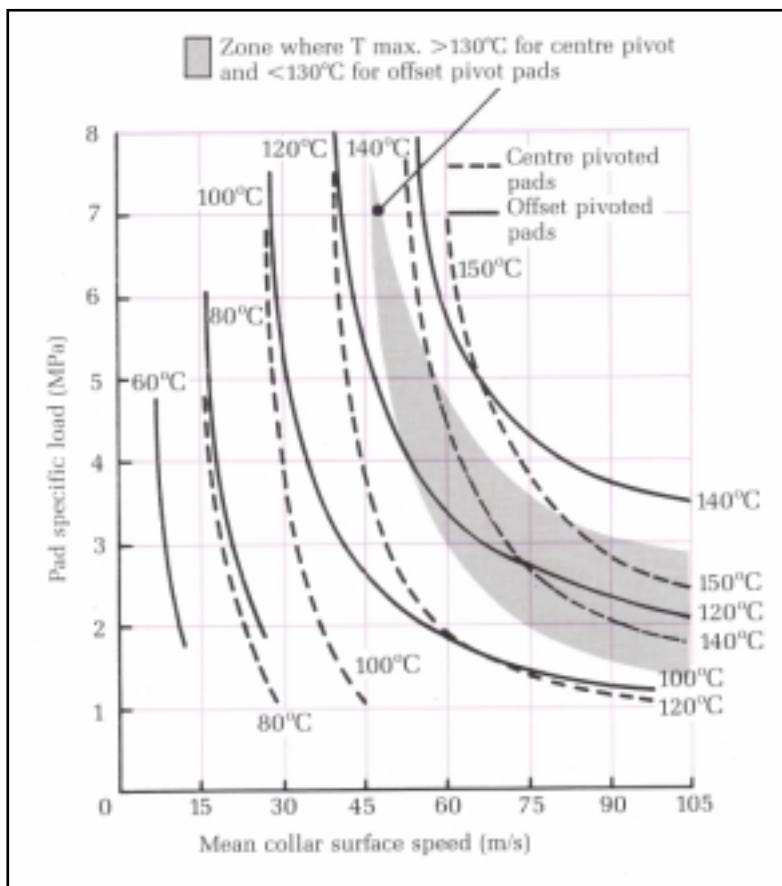

Fig 5. Offset Pivots: effect on thrust pad temperature

# Instrumentation

Continued

## Thrust Load Measurement

Most sizes of WBC thrust bearings can be supplied with a means for measuring the applied axial load. This may be done either with strain gauge load cells, or with a Hydraulic Thrust Meter System.

### 1 Load Cell System

A number of strain gauge load cells are positioned in the back of the thrust rings as shown in Fig 8. Note that the cells have to be placed under either each pad or each pair of pads to obtain accurate readings.

### 2 Hydraulic Thrust Meter System

A hydraulic piston is located behind each thrust pad, these pistons being interconnected to a high pressure oil supply. The pressure in the system then gives a measure of the applied thrust load. Fig 9 shows a typical installation of this type complete with system control panel which incorporates the high pressure oil pump and system pressure gauge calibrated to read thrust load.

This system is most suited to bearings of pad size 415 and above. When combined with suitable hydraulic reservoirs, it can be used as a resonance changing system to reduce axial vibrations.

Note: For both these systems it will normally be necessary to increase the overall axial thickness of the thrust ring.

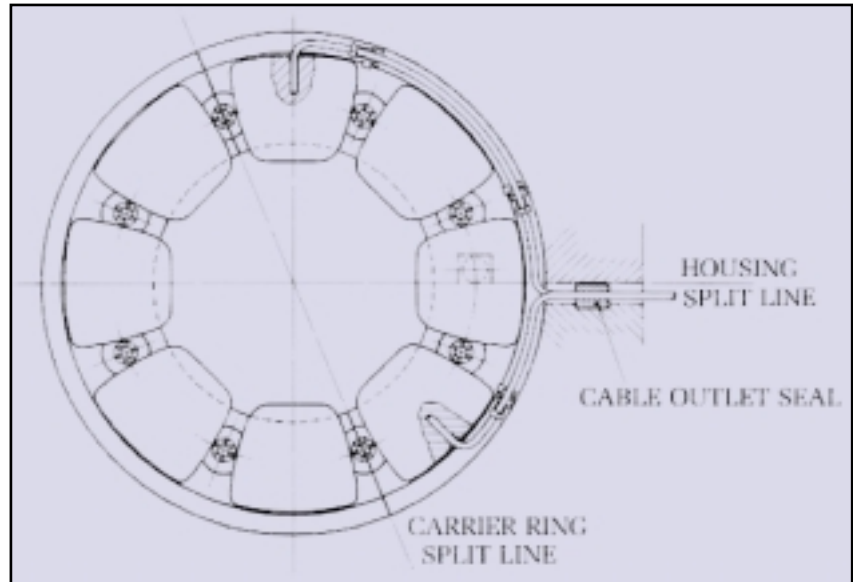

Fig 6. Temperature Sensors: typical method of fitting to thrust rings

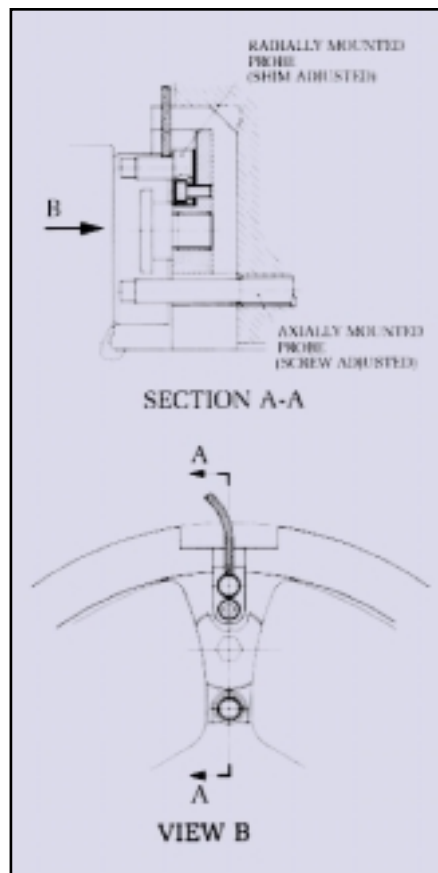

Fig 7. Proximity Probes: Alternative methods of fitting to thrust rings



# Instrumentation

Continued

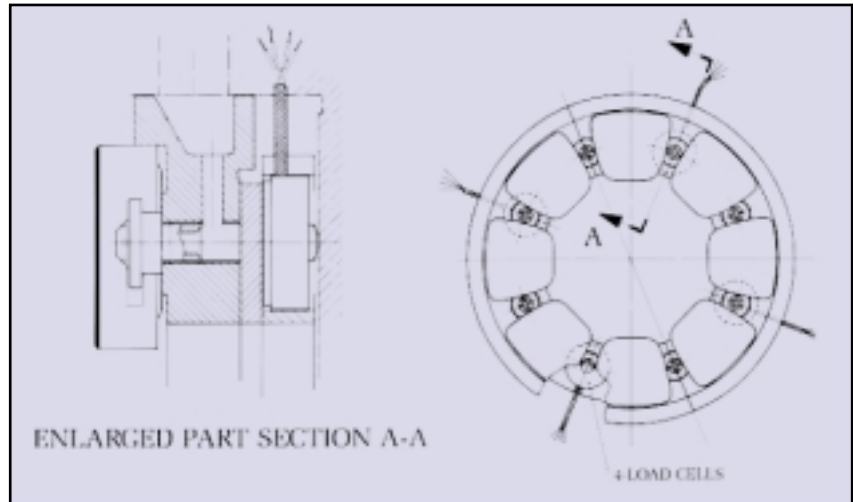

Fig 8. Load Cells: Installation in Directed Lubrication carrier ring

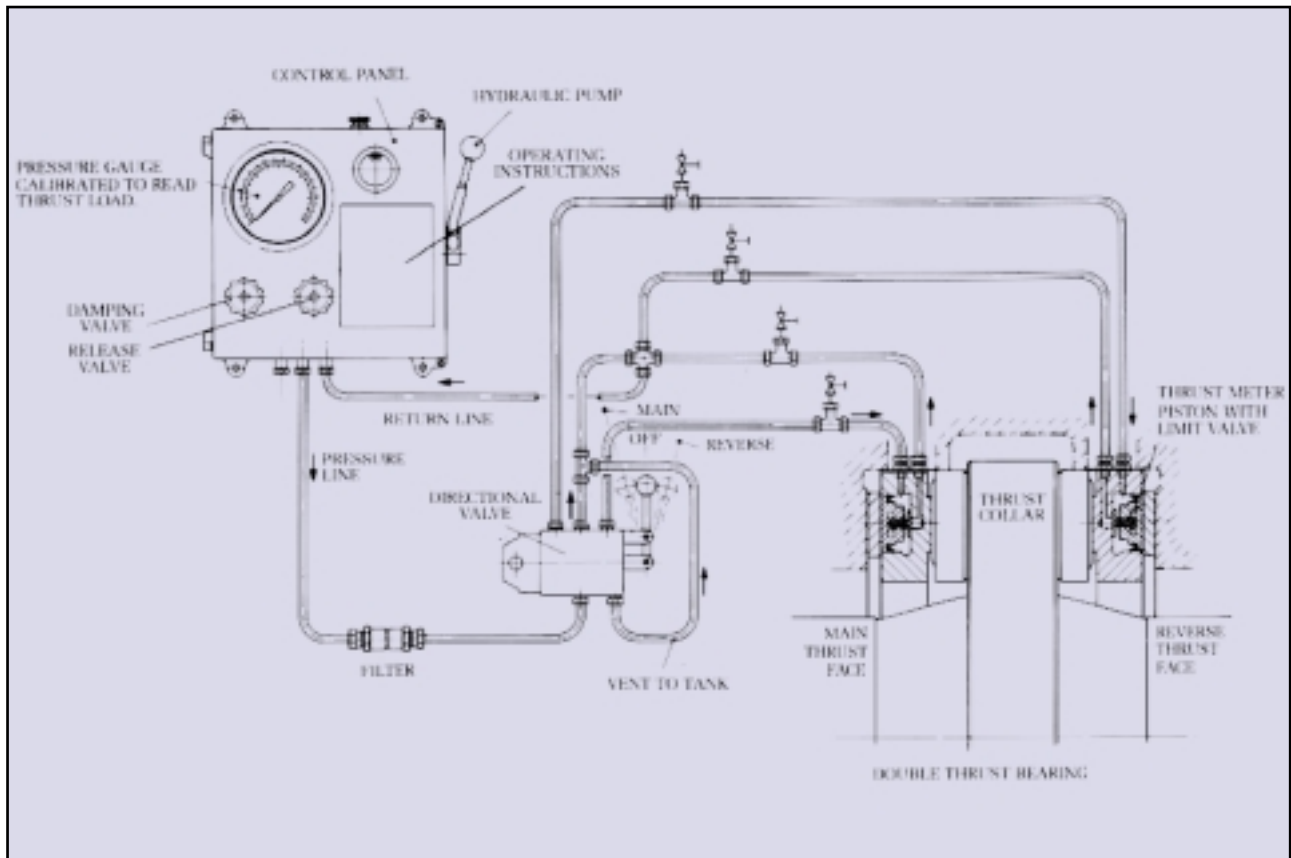

Fig 9. Hydraulic Thrust Metering: arrangement diagram

# 7

## Hydrostatic Jacking

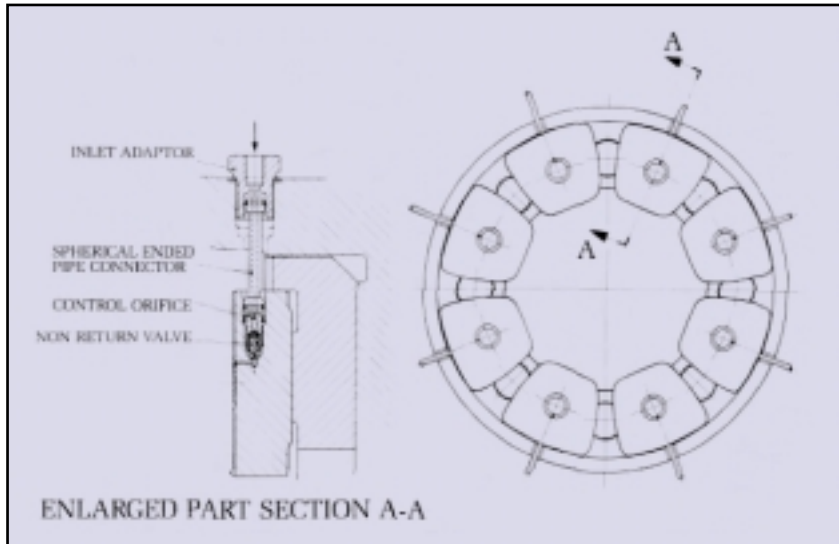

Fig 10. jacking oil system in thrust bearing

At the instant of start up, the load carrying capacity of tilting pad thrust bearings is restricted to approximately 60% of the maximum figure given in the Size Tables. If the start up load on a bearing exceeds this figure and a larger bearing is not a feasible option, WBC can supply thrust bearings fitted with a hydrostatic jacking system to allow the bearing to operate with heavy loads at low speeds. This system introduces oil at high pressure (typically 100-150 bar) between the bearing surfaces to form a hydrostatic oil film; Fig 10 shows a typical bearing of this type.



M8538/0 featuring high pressure jacking oil for start up and run down. Jacking oil annulus can be seen on the surface of each thrust pad.

## Reference Codes

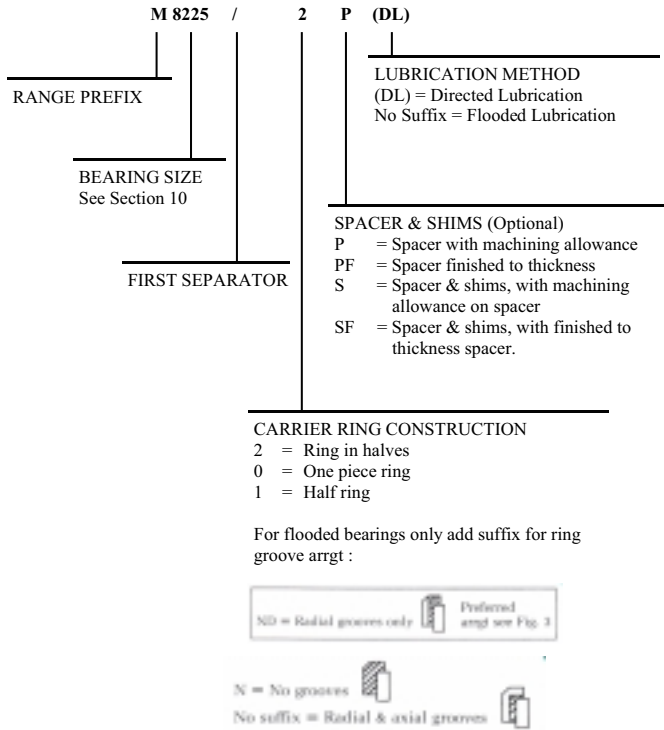

Fig 11. Reference codes for thrust rings

For convenient reference, every thrust ring has a distinctive number, and, by combining the numbers, any desired arrangement of bearing may be defined. The number is in two parts; the first part denotes the SIZE of the thrust ring and will be found at the left hand side of the Size Tables. This number is a combination of the number of pads in a complete ring and the size of pads used. The second part of the reference number is a CODE controlling the type of ring, ie one piece or in halves etc. Particulars of the code numbers are given in Fig 11. The complete reference number is thus SIZE/CODE for each thrust ring. If it is desired to use a reduced thrust surface by omitting some of the thrust pads, add in brackets a fraction to indicate the number of pads required from the total possible (see example 5 below).

In the case of double thrust bearings having equal thrust rings at each side, the reference number should be written SIZE/CODE-CODE. Unequal bearings, having one thrust ring for the main thrust, and a smaller ring for the reverse thrust should be written SIZE/CODE-SIZE/CODE. The more common arrangements of bearings are illustrated in Fig 12. The following examples will illustrate the reference system:

- 1 Reference Code M6225/OND**  
Series 6 one piece thrust ring: with 6 thrust pads size 225. Carrier ring with radial grooves only.
- 2 Reference Code M8246/2P (DL)**  
Series 8 thrust ring in halves with Directed Lubrication and spacer with machining allowance.

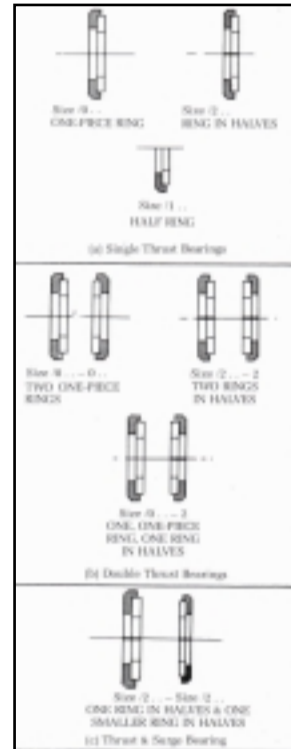

Fig 12. Some common arrangements of bearings and their reference code.

- 3 Reference Code M8246/2NDSF**  
Series 8 thrust ring in halves with spacer finished to thickness and shims. Carrier ring with radial grooves only.
- 4 Reference Code M11190/2S-2S (DL)**  
Double thrust bearing, two rings Series 11, each in halves with Directed Lubrication, spacers and shims, allowance left on thickness for finishing.
- 5 Reference Code M8348/2P - M14190/2P (7/14)**  
Unequal double bearing with one main thrust ring, and one surge thrust ring, (fitted with 7 pads out of 14). Both rings in halves with spacers, having allowance for finishing. Carrier rings with radial and axial grooves.

The selection of the appropriate MS tilting pad thrust bearing for given operating conditions may be accomplished in two stages:

### 1 Preliminary selection

This may be made in terms of nominal load capacity and physical size by using Fig 13 and the Size Tables on pages 20-35.

### 2 Confirmation of selection

The preliminary selection needs to be confirmed to take into account the actual sliding speeds and oil conditions. When placing an order we recommend that WBC confirm the bearing selection using our full computer program.

Fig 13. Selection chart for thrust bearings

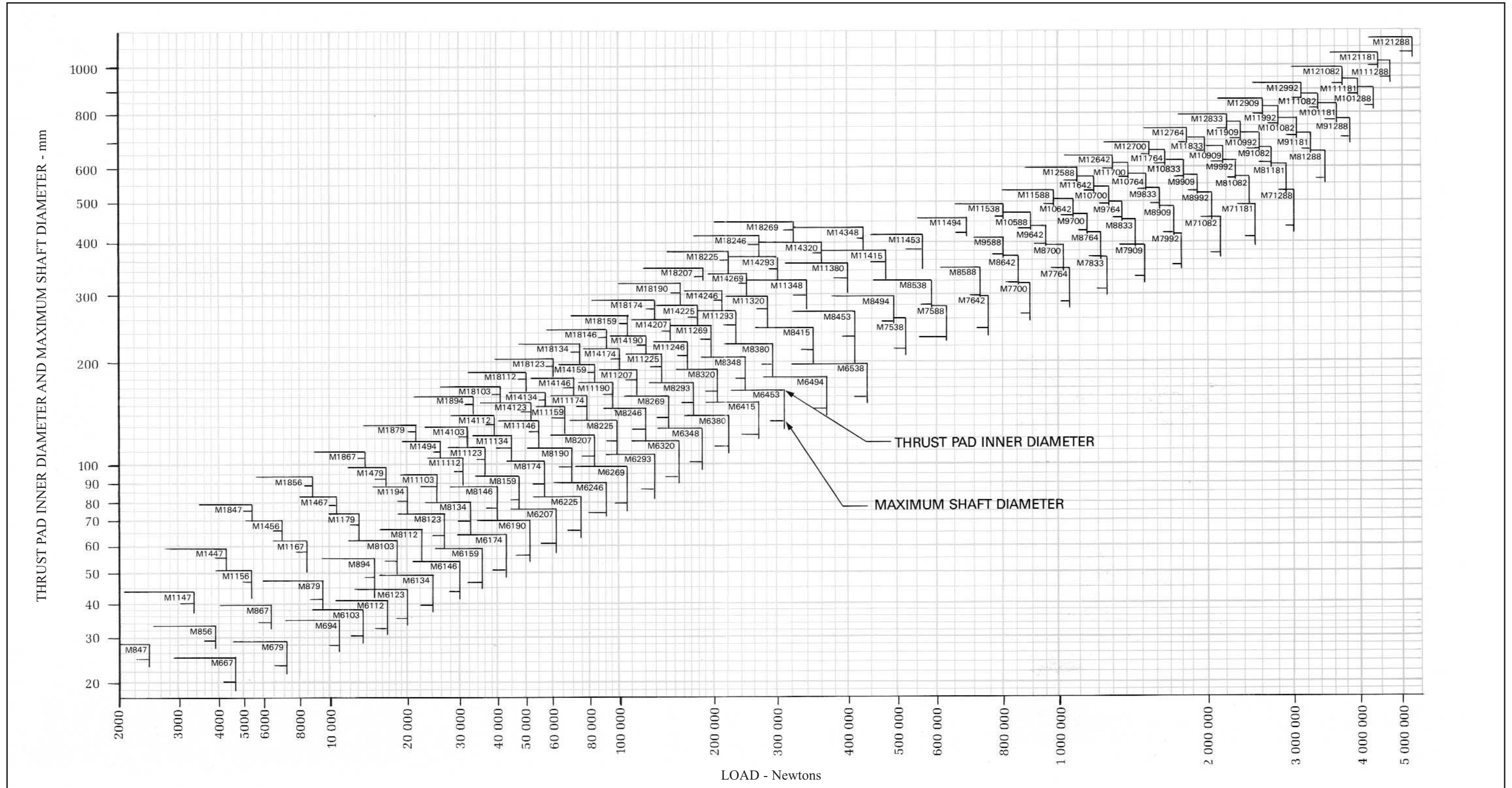



# 10

## Size Tables

Series	Max Shaft	Max Load	Page
<b>Series 6</b>	160 mm	43 tonne	20
<b>Series 8</b>	275 mm	58 tonne	22
<b>Series 11</b>	460 mm	80 tonne	24
<b>Series 14</b>	400 mm	43 tonne	26
<b>Series 18</b>	420 mm	32 tonne	28
<b>Series 7 Large</b>	440 mm	305 tonne	30
<b>Series 8 Large</b>	570 mm	350 tonne	31
<b>Series 9 Large</b>	710 mm	393 tonne	32
<b>Series 10 Large</b>	830 mm	437 tonne	33
<b>Series 11 Large</b>	950 mm	480 tonne	34
<b>Series 12 Large</b>	1080 mm	524 tonne	35

These tables show sizes of bearings which you will normally have selected using the procedures in Section 9.

The Size Tables are in two groups: 6, 8, 11, 14 and 18 pad bearings for loads up to 80 tonne and 460mm shaft diameter, and 7, 8, 9, 10, 11 and 12 pad large bearings for thrust loads up to 524 tonne and 1080mm shaft diameter.

The size number is made up of the number of pads followed by the pad size. Thus M8207 is an 8 pad bearing of pad size 207, and M1194 an 11 pad bearing of pad size 94.

As you will see from Fig 13 small numbers of large pads suit small shafts with high thrust loads, and large numbers of small pads suit large shafts with low loads. There are numerous combinations in between.

When you have confirmed sizes from these tables, refer to Section 8 which shows how to complete the thrust bearing reference number by adding the features we need to know for manufacture.

M6207/2 (DL) fitted with Thermocouples ready for high speed petro-chemical application. Note half pad stops which avoid handling loose pads on assembly.

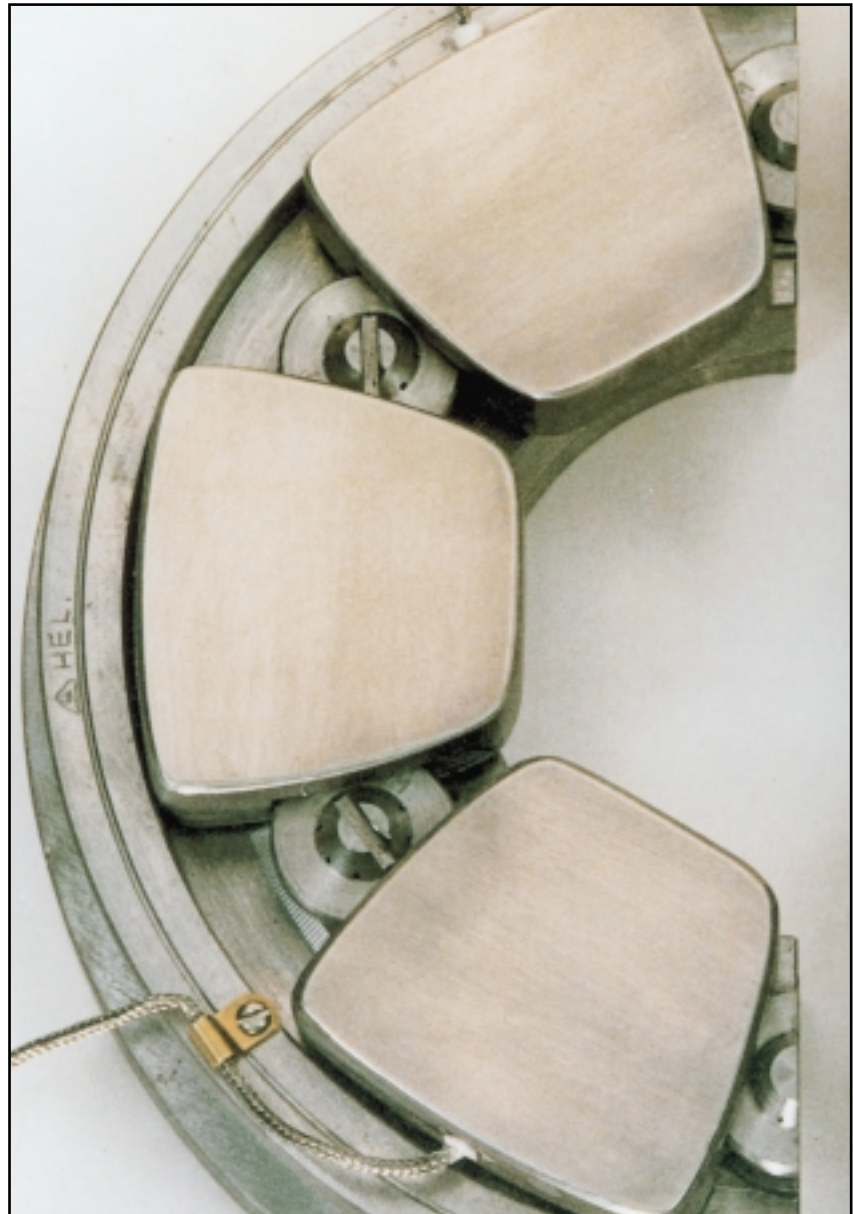



# Series 6

Max Shaft 160mm Max Load 43 tonne

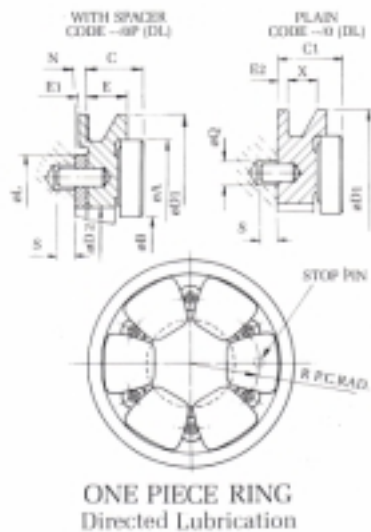

**ONE PIECE RING**  
Directed Lubrication

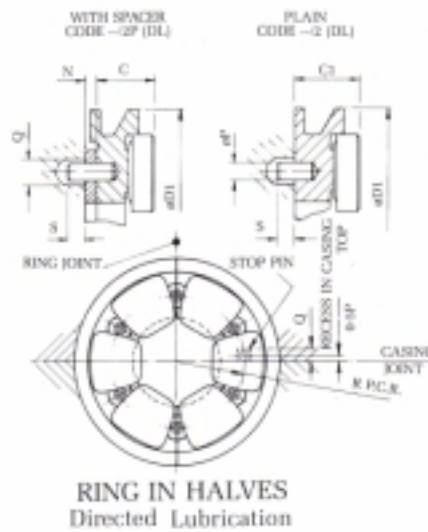

**RING IN HALVES**  
Directed Lubrication

Size	Thrust pad		Carrier Ring Dimensions													Thrust surface mm <sup>2</sup>	Mean dia. d	Allow. spec load MPa	Max load (see page 17) Newton	Total Axial Clearance mm
	O. Dia	I. Dia	Thickness		Ring O. Dia	Housing bore	Ring O. Dia	Housing bore	I. Dia											
	A	B	C	C1	D		D1		D2	E	E1	E2	X	F						
M667	59	25	15.890 15.850	18.090 18.050	71.34 71.27	71.51 71.44	71.41 71.38	71.47 71.44	30	13	2.2	3	9	4	1 720	42.5	2.65	4 558	0.20	
M679	71	29	17.470 17.430	19.670 19.630	82.43 82.34	82.64 82.55	82.51 82.48	82.59 82.55	35	13	2.2	3	9.5	5	2 430	50.5	2.9	7 047	0.25	
M694	84	35	19.060 19.020	21.260 21.220	98.31 98.22	98.52 98.43	98.39 98.36	98.47 98.43	41	14	2.2	3	10.5	5	3 450	60.1	3.2	11 040	0.25	
M6103	92	38	20.650 20.610	23.953 23.897	107.83 107.74	108.04 107.95	107.91 107.88	107.99 107.95	44	15	3.3	3.5	12	6	4 100	65.8	3.3	13 530	0.30	
M6112	100	41	22.243 22.187	25.543 25.487	115.77 115.68	115.98 115.89	115.85 115.82	115.93 115.89	49	17	3.3	4	12	6	4 900	71.7	3.4	16 660	0.30	
M6123	110	44.5	23.823 23.767	27.123 27.067	126.85 126.75	127.10 127.00	126.96 126.92	127.04 127.00	54	17	3.3	4	13	6	5 800	78.2	3.45	20 010	0.30	
M6134	119	49	25.413 25.357	28.713 28.657	139.55 139.55	139.80 139.70	139.66 139.62	139.74 139.70	59	19	3.3	4	14.5	6	6 900	85.1	3.5	24 150	0.35	
M6146	130	54	27.003 26.947	30.303 30.247	147.49 147.39	147.74 147.64	147.60 147.56	147.68 147.64	63	20	3.3	4	15	6	8 250	93	3.6	29 700	0.35	
M6159	143	58.5	28.593 28.537	31.893 31.837	164.95 164.85	165.20 165.10	165.06 165.02	165.14 165.10	70	21	3.3	4.5	15	7	9 800	102	3.6	35 280	0.35	
M6174	155	64	31.763 31.707	35.063 35.007	179.24 179.14	179.49 179.39	179.35 179.31	179.43 179.39	76	22	3.3	4.5	16.5	7	11 700	111	3.65	42 700	0.40	
M6190	168	70	34.943 34.887	38.943 38.887	193.51 193.39	193.79 193.68	193.63 193.58	193.73 193.68	83	25	4	5	19.5	8	13 900	120.4	3.7	51 430	0.40	
M6207	184	76	38.113 38.057	42.115 42.044	209.38 209.26	209.66 209.55	209.50 209.45	209.60 209.55	89	27	4	5	21	10	16 600	132	3.7	61 420	0.40	
M6225	200	82.5	41.295 41.224	45.295 45.224	228.43 228.31	228.71 228.60	228.55 228.50	228.65 228.60	98	30	4	5.5	23	10	19 700	143	3.75	73 875	0.50	
M6246	219	91	44.465 44.394	48.465 48.394	247.48 247.36	247.76 247.65	247.60 247.55	247.70 247.65	108	32	4	6	23.5	11	23 500	157	3.8	89 300	0.50	
M6269	24	98.5	47.645 47.574	51.645 51.574	266.51 266.38	266.83 266.70	266.64 266.59	266.75 266.70	117	33	4	6	25	11	28 000	172	3.8	106 400	0.50	
M6293	261	108	50.815 50.744	54.815 54.744	291.91 291.78	292.23 292.10	292.04 291.99	292.15 292.10	129	35	4	6	27	11	33 200	187	3.85	127 820	0.50	
M6320	286	117	57.165 57.094	61.165 61.094	317.29 317.15	317.64 317.50	317.44 317.38	317.56 317.50	140	40	4	6	31.5	13	39 700	205	3.85	152 845	0.60	
M6348	310	128	60.345 60.274	64.345 64.274	342.69 342.55	342.99 342.90	342.84 342.78	342.96 342.90	152	41	4	6	31	13	47 000	222	3.9	183 300	0.60	
M6380	340	140	66.700 66.609	73.700 73.609	371.27 371.13	371.62 371.48	371.42 371.36	371.54 371.48	165	46	7	9	35	14	56 200	243	3.9	219 180	0.60	
M6415	369	153	73.050 72.959	80.050 79.959	406.17 406.01	406.55 406.40	406.33 406.27	406.46 406.40	184	51	7	9	40	16	66 700	264	3.9	266 130	0.60	
M6453	403	167	79.400 79.309	86.400 86.309	441.10 440.94	441.48 441.33	441.26 441.20	441.39 441.33	263	56	7	9	43.5	16	79 300	290	3.9	309 270	0.70	
M6494	439	182	85.750 85.659	95.450 95.359	482.37 482.21	482.75 482.60	482.53 482.47	482.66 482.60	222	59	9.7	11	47.5	17	94 400	315	3.9	368 160	0.70	
M6538	478	198	92.020 91.929	101.720 101.629	523.62 523.44	524.05 523.88	523.80 523.73	523.95 523.88	241	64	9.7	11	50	19	111 500	343	3.9	434 850	0.70	

All dimensions are in mm

# Series 6

Max Shaft 160mm Max Load 43 tonne

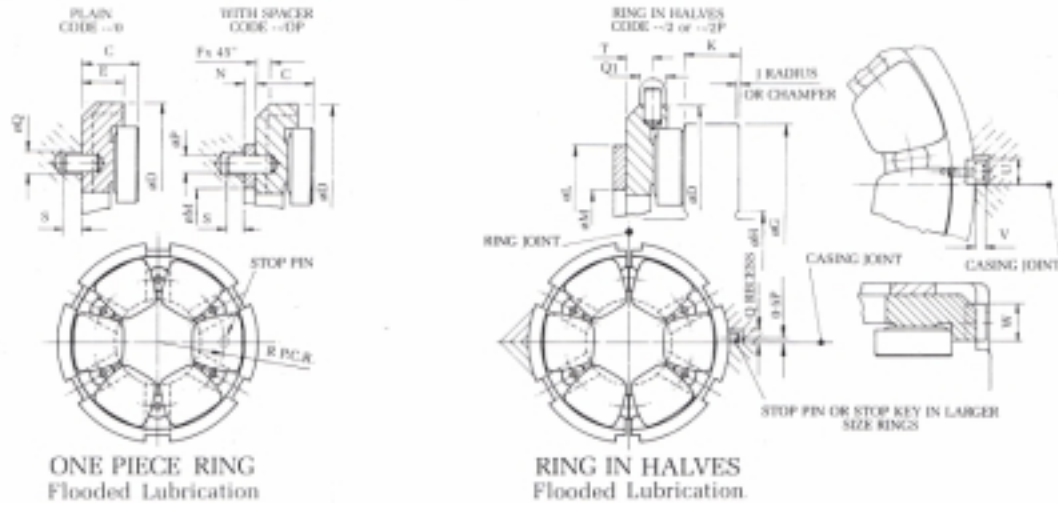

Collar Sizes				Spacer Dia.		Spacer Thickness (N)		Stop pin or key									Approx weight without spacer kg	Size
O. Dia G	I. Dia H	Rad J	Thick. K	O. Dia L	I. Dia M	Min N1	With M/c allow. N2	P	Q	Q1	R	S	T	U	V	W		
62	23	0.4	11	54	32	3.2	4.8	3.2	4.0	7	21.4	3	8	-	-	-	0.29	M667
74	27	0.4	13	62	38	3.2	4.8	4.0	5.0	7	26.2	4	8	-	-	-	0.41	M679
88	32	0.4	16	75	44	3.2	4.8	4.8	6.0	8	30.2	5	10	-	-	-	0.65	M694
95	36	0.4	17	83	51	4.8	6.4	4.8	6.0	8	33.3	5	11	-	-	-	0.87	M6103
105	38	0.4	19	92	54	4.8	6.4	5.6	6.5	9	36.6	6	12	-	-	-	1.07	M6112
113	43	0.8	21	98	60	4.8	6.4	5.6	6.5	9	39.7	6	12	-	-	-	1.38	M6123
122	46	0.8	22	105	67	4.8	6.4	6.4	7.5	10	42.9	7	13	-	-	-	1.80	M6134
134	51	0.8	25	114	67	4.8	6.4	7.9	9.0	11	46.0	8	13	-	-	-	2.09	M6146
146	56	0.8	27	124	79	4.8	6.4	7.9	9.0	11	50.8	8	14				3.58	M6159
159	61	0.8	30	137	89	4.8	6.4	9.5	11.0	13	55.6	8	16				3.04	M6174
171	67	0.8	32	146	95	6.4	8.7	9.5	11.0	14	60.3	8	16	-	-	-	4.84	M6190
189	72	0.8	35	159	105	6.4	8.7	11.1	13.0	16	66.7	8	19	-	-	-	6.19	M6207
203	79	0.8	38	175	111	6.4	8.7	11.1	13.0	16	71.4	8	19	-	-	-	8.14	M6225
224	87	0.8	43	194	124	6.4	8.7	12.7	14.0	17	79.4	10	22	-	-	-	10.50	M6246
243	97	0.8	48	213	137	6.4	8.7	12.7	14.0	17	87.3	10	22	-	-	-	12.40	M6269
265	104	0.8	53	232	149	6.4	8.7	12.7	14.0	17	95.3	10	-	15.9	5.6	28.6	16.90	M6293
289	116	0.8	56	251	162	6.4	8.7	15.9	18.0	21	103.2	13	-	15.9	5.6	31.8	21.81	M6320
315	124	0.8	64	270	178	6.4	8.7	19.1	21.0	24	112.7	13	-	19.1	6.4	31.8	27.06	M6348
343	138	0.8	67	295	194	9.5	12.7	19.1	21.0	26	122.2	13	-	19.1	6.4	38.1	35.37	M6380
375	149	0.8	76	324	222	9.5	12.7	19.1	21.0	26	133.4	13	-	19.1	6.4	38.1	46.15	M6415
410	162	1.5	79	356	229	9.5	12.7	22.2	24.0	29	146.1	16	-	19.1	6.4	44.5	58.15	M6453
447	177	1.5	92	387	251	12.7	15.9	25.4	27.0	32	158.8	16	-	22.2	8	44.5	74.97	M6494
486	194	1.5	95	419	267	12.7	15.9	25.4	27.0	32	171.5	16	-	22.2	8	50.8	91.02	M6538

All dimensions are in mm

# Series 8

Max Shaft 275mm Max Load 58 tonne

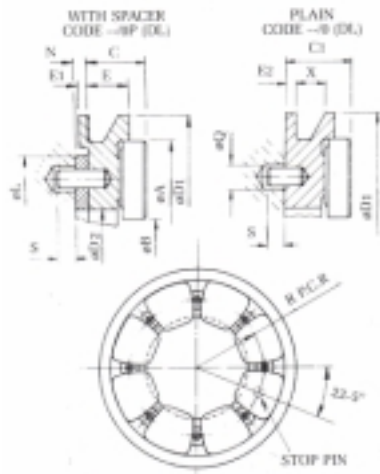

**ONE PIECE RING**  
Directed Lubrication

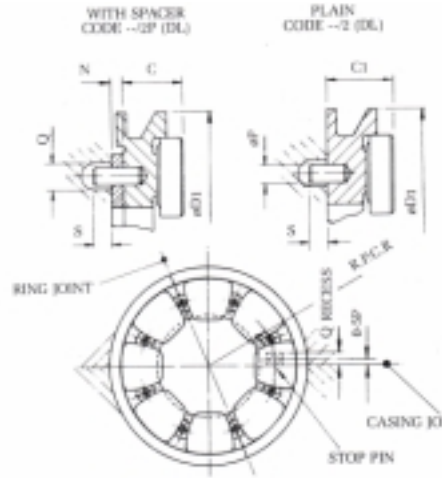

**RING IN HALVES**  
Directed Lubrication

Size	Thrust pad		Carrier Ring Dimensions													Thrust surface mm <sup>2</sup>	Mean dia. d	Allow. spec load MPa	Max load (see page 17) Newton	Total Axial Clearance mm	
	O. Dia A	I. Dia B	Thickness		Ring O. Dia D	Housing bore D1	Ring O. Dia D2	Housing bore E	I. Dia E1	E2	X	F	E1	E2	X						F
			C	C1																	
M847	52.5	28.5	12.710 12.670	-	63.40 63.33	63.57 63.50	-	-	31	10	-	-	-	3	1 140	40.9	2.4	2 394	0.20		
M856	62	33.5	14.300 14.260	16.500 16.460	72.93 72.86	73.10 73.03	73.00 72.97	73.06 73.03	36	12	2.2	2.5	8.5	4	1 615	48.3	2.4	3 876	0.20		
M867	74.5	39.5	15.890 15.850	18.090 18.050	85.61 85.52	85.82 85.73	85.69 85.66	85.77 85.73	44	13	2.2	3	9	4	2 360	57.9	2.65	6 254	0.20		
M879	87.5	47.5	17.470 17.430	19.670 19.630	101.48 101.39	101.69 101.60	101.56 101.53	101.64 101.60	53	13	2.2	3	9.5	5	3 250	68.1	2.9	9 425	0.25		
M894	105	55.5	19.060 19.020	21.260 21.220	120.51 120.41	120.75 120.65	120.61 120.57	120.69 120.65	63	14	2.2	3	10.5	5	4 610	81.8	3.2	14 752	0.25		
M8103	114	62	20.650 20.610	23.653 23.897	130.04 120.94	130.28 130.18	130.14 130.10	130.22 130.18	67	16	3.3	3.5	12	6	5 500	89.2	3.3	18 150	0.30		
M8112	124	66.5	22.243 22.187	25.543 25.487	139.56 139.46	139.80 139.70	139.66 139.62	139.74 139.70	74	17	3.3	4	12	6	6 500	96.5	3.4	22 100	0.30		
M8123	137	73	23.823 23.707	27.123 27.067	152.26 152.16	152.50 152.40	152.36 152.32	152.44 152.40	82	17	3.3	4	13	6	7 750	106	3.45	26 737	0.30		
M8134	149	79.5	25.413 25.357	28.713 28.657	168.14 168.04	168.38 168.28	168.24 168.20	168.32 168.28	90	19	3.3	4	14.5	6	9 250	116	3.5	32 375	0.35		
M8146	162	87.5	27.003 26.947	30.303 30.247	180.79 180.68	181.08 180.96	180.91 180.86	181.01 180.96	98	20	3.3	4	15	6	11 000	126	3.6	39 600	0.35		
M8159	176	93.5	28.593 28.537	31.893 31.837	196.68 196.57	196.97 196.85	196.80 196.75	196.90 196.85	105	21	3.3	4.5	15	6	13 100	137	3.6	47 160	0.35		
M8174	192	103	31.763 31.707	35.063 35.007	215.73 215.62	216.02 215.90	215.85 215.80	215.95 215.90	115	22	3.3	4.5	16.5	7	15 500	150	3.65	56 575	0.40		
M8190	210	113	34.943 34.887	38.943 38.887	234.75 234.67	235.07 234.95	234.90 234.85	235.00 234.95	126	25	4	5	19.5	8	18 600	163	3.7	68 820	0.40		
M8207	229	122	38.113 38.057	42.115 42.044	253.81 253.68	254.13 254.00	253.94 253.89	254.05 254.00	138	27	4	5	21	10	22 100	178	3.7	81 770	0.40		
M8225	251	135	41.295 41.224	45.295 45.224	279.21 279.08	279.53 279.40	279.34 279.29	279.45 279.40	150	30	4	5.5	23	10	26 300	196	3.75	98 625	0.50		
M8246	273	146	44.465 44.394	48.465 48.394	301.44 301.31	301.76 301.63	301.57 301.52	301.68 301.63	164	32	4	6	23.5	11	31 300	213	3.8	118 940	0.50		
M8269	297	159	47.645 47.574	51.645 51.574	323.64 323.50	323.99 323.85	323.79 323.73	323.91 323.85	179	33	4	6	25	11	37 300	232	3.8	141 740	0.50		
M8293	324	175	50.815 50.744	57.815 57.744	355.39 355.25	355.74 355.60	355.54 355.48	355.66 355.60	195	35	7	7	28	11	44 300	253	3.85	170 555	0.50		
M8320	354	191	57.165 57.094	64.165 64.094	383.97 383.83	384.32 384.18	384.12 384.06	384.24 384.18	213	40	7	7	32.5	13	52 900	276	3.85	203 665	0.60		
M8348	384	206	60.345 60.274	67.350 67.259	415.70 415.55	416.09 415.93	415.86 415.80	415.99 415.93	232	41	7	8	32.5	13	62 700	300	3.9	244 530	0.60		
M8380	419	225	66.700 66.609	73.700 73.609	453.80 453.65	454.19 454.03	453.96 453.90	454.09 454.03	253	46	7	8	37	14	74 800	328	3.9	291 720	0.60		
M8415	457	246	73.050 72.959	80.050 79.959	495.07 494.92	495.46 495.30	495.23 495.17	495.36 495.30	277	51	7	9	40	16	89 000	358	3.9	347 100	0.60		
M8453	502	268	79.400 79.309	89.100 89.009	539.49 539.32	539.93 539.75	539.67 539.60	539.82 539.75	301	56	9.7	10	45.5	17	105 800	391	3.9	412 620	0.70		
M8494	546	294	85.750 85.659	95.450 95.359	583.94 583.77	584.38 584.20	584.12 584.05	584.27 584.20	329	59	9.7	10	46.5	17	126 000	425	3.9	491 400	0.70		
M8538	597	321	92.100 92.009	101.800 101.709	641.06 640.86	641.55 641.35	641.27 641.19	641.43 641.35	358	64	9.7	11	50	19	149 500	465	3.9	583 050	0.70		

All dimensions are in mm

# Series 8

Max Shaft 275mm Max Load 58 tonne

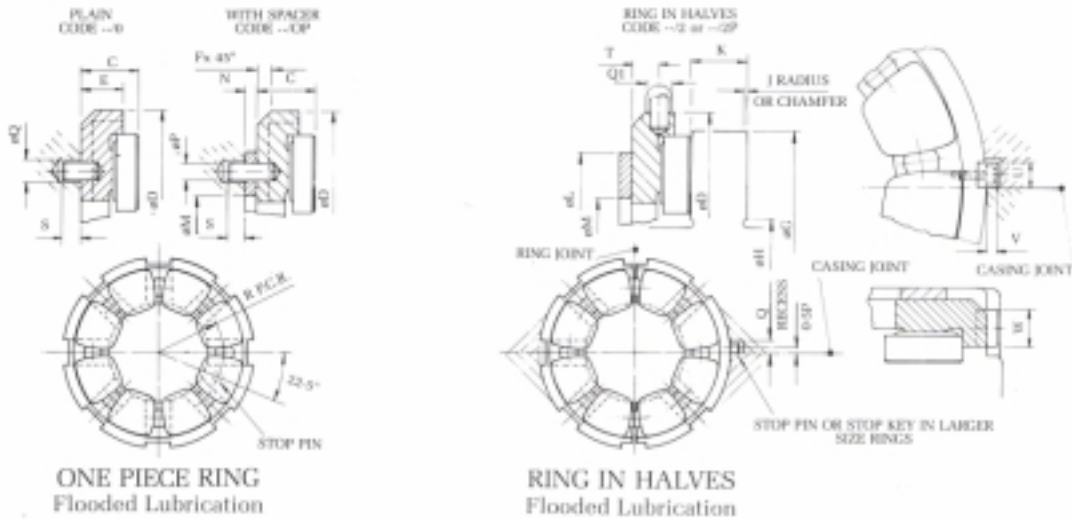

Collar Sizes				Spacer Dia.		Spacer Thickness (N)		Stop pin or key									Approx weight without spacer kg	Size
O. Dia G	I. Dia H	Rad J	Thick. K	O. Dia L	I. Dia M	Min N1	With M/c allow. N2	P	Q	Q1	R	S	T	U	V	W		
54	27	0.4	7	51	32	3.2	4.8	3.2	4.0	7	20.6	3.5	6	-	-	-	0.17	M847
64	32	0.4	9	60	38	3.2	4.8	4.0	5.0	7	24.6	4	7	-	-	-	0.24	M856
76	38	0.4	10	70	48	3.2	4.8	4.8	6.0	8	29.4	5	8	-	-	-	0.38	M867
90	43	0.8	13	81	56	3.2	4.8	4.8	6.0	8	34.1	5	9	-	-	-	0.56	M879
108	54	0.8	16	95	70	3.2	4.8	5.6	6.5	9	41.3	6	10	-	-	-	0.87	M894
117	59	0.8	17	105	73	4.8	6.4	6.4	7.5	10	44.5	7	10	-	-	-	1.13	M8103
127	64	0.8	19	113	81	4.8	6.4	6.4	7.5	10	48.4	7	10	-	-	-	1.38	M8112
140	70	0.8	21	125	87	4.8	6.4	6.4	7.5	10	53.2	7	11	-	-	-	1.75	M8123
152	76	0.8	22	135	97	4.8	6.4	7.9	9.0	11	57.9	8	13	-	-	-	2.32	M8134
165	84	0.8	25	149	105	4.8	6.4	7.9	9.0	11	63.5	8	13	-	-	-	2.80	M8146
179	92	0.8	27	162	117	4.8	6.4	7.9	9.0	11	69.9	8	13	-	-	-	3.60	M8159
195	100	0.8	30	178	127	4.8	6.4	9.5	11.0	13	76.2	8	14	-	-	-	4.68	M8174
213	110	0.8	32	191	140	6.4	8.7	9.5	11.0	14	82.6	8	17	-	-	-	6.30	M8190
232	119	0.8	35	206	149	6.4	8.7	11.1	13.0	16	88.9	8	17	-	-	-	8.01	M8207
254	132	0.8	38	229	165	6.4	8.7	12.7	14.0	17	98.4	10	19	-	-	-	10.76	M8225
276	141	0.8	43	244	181	6.4	8.7	12.7	14.0	17	106.4	10	-	15.9	5.6	25.4	13.20	M8246
300	156	0.8	48	270	194	6.4	8.7	15.9	18.0	21	115.9	13	-	15.9	5.6	28.6	16.10	M8269
327	170	0.8	51	292	216	9.5	12.7	15.9	18.0	22	127.0	13	-	15.9	5.6	28.6	21.11	M8293
357	187	0.8	56	321	232	9.5	12.7	19.1	21.0	26	138.1	13	-	15.9	5.6	31.8	28.06	M8320
391	200	1.5	60	346	257	9.5	12.7	19.1	21.0	26	150.8	13	-	19.1	6.4	31.8	34.98	M8348
425	219	1.5	67	378	276	9.5	12.7	22.2	24.0	29	163.5	16	-	19.1	6.4	38.1	46.46	M8380
464	240	1.5	73	416	302	9.5	12.7	22.2	24.0	29	179.4	16	-	19.1	6.4	38.1	60.40	M8415
508	264	1.5	79	448	333	12.7	15.9	25.4	27.0	32	195.3	16	-	22.2	8	44.5	76.86	M8453
552	287	1.5	86	489	362	12.7	15.9	25.4	27.0	32	212.7	16	-	22.2	8	44.5	96.66	M8494
603	314	1.5	95	533	394	12.7	15.9	28.6	31.0	35	231.8	19	-	22.2	8	50.8	125.02	M8538

All dimensions are in mm

# Series 11

Max Shaft 460mm Max Load 80 tonne

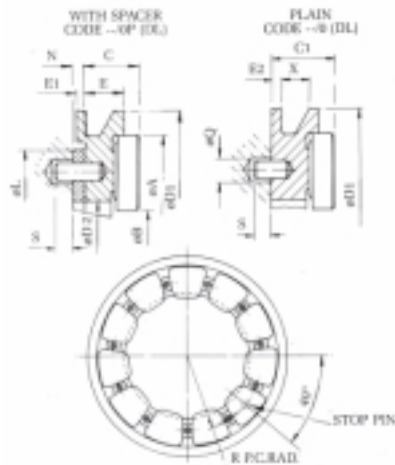

**ONE PIECE RING**  
Directed Lubrication

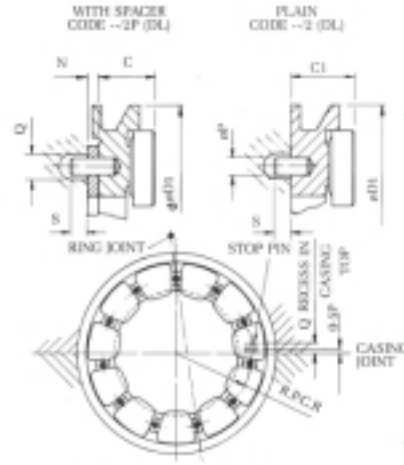

**RING IN HALVES**  
Directed Lubrication

Size	Thrust pad		Carrier Ring Dimensions													Thrust surface mm <sup>2</sup>	Mean dia. d	Allow. spec. load MPa	Max load (see page 17) Newton	Total Axial Clearance mm
	O. Dia	I. Dia	Thickness		Ring O. Dia	Housing bore	Ring O. Dia	Housing bore	I. Dia	E	E1	E2	X	F						
			C	C1											D					
M1147	68.5	43.5	12.710 12.670	-	77.69 77.62	77.86 77.79	-	-	46	10	-	-	-	3	1 575	56.9	2.1	3 307	0.20	
M1156	79.5	51	14.300 14.260	16.500 16.460	91.96 91.87	92.17 92.08	92.04 92.01	92.12 92.08	55	12	2.2	2.5	8.5	4	2 220	66.5	2.4	5 328	0.20	
M1167	95.5	62	15.890 15.850	18.090 18.050	111.01 110.92	111.22 111.13	111.09 111.06	111.17 111.13	66	13	2.2	2.5	10	4	3 160	79.2	2.65	8 374	0.20	
M1 179	114	73	17.470 17.430	19.670 19.630	130.04 129.94	130.28 130.18	130.14 130.10	130.22 130.18	79	13	2.2	3	9	5	4 460	94.7	2.9	12 934	0.25	
M1194	135	87.5	20.650 20.610	23.953 23.897	152.26 152.16	152.50 152.40	152.36 152.32	152.44 152.40	94	16	3.3	3.5	12	6	6 300	112	3.2	20 160	0.25	
M11103	148	95.5	22.243 22.187	25.543 25.487	168.14 168.04	168.38 168.28	168.24 168.20	168.32 168.28	102	17	3.3	3.5	13.5	6	7 550	123	3.3	24 915	0.30	
M11112	162	105	23.823 23.707	27.123 27.067	180.81 180.70	181.10 180.98	180.93 180.88	181.03 180.98	112	19	3.3	4	14.5	6	8 950	135	3.4	30 430	0.30	
M11123	175	113	25.413 25.357	28.713 28.657	196.68 196.57	196.97 196.85	196.80 196.75	196.90 196.85	121	19	3.3	4	14.5	6	10 600	145	3.45	36 040	0.30	
M11134	191	122	27.003 26.947	30.303 30.247	212.56 212.45	212.85 212.73	212.68 212.63	212.78 212.73	133	21	3.3	4	16	7	12 700	158	3.5	44 450	0.35	
M1 1146	210	135	28.593 28.537	32.593 32.537	234.78 234.67	235.07 234.95	234.90 234.85	235.00 234.95	146	21	4	4	16.5	7	15 100	174	3.6	54 360	0.35	
M11159	229	148	30.173 30.117	34.173 34.117	253.81 253.68	254.13 254.00	253.94 253.89	254.05 254.00	159	22	4	4.5	17	7	17 900	191	3.6	64 440	0.35	
M11174	249	160	31.763 31.707	35.763 35.707	279.21 279.08	279.53 279.40	279.34 279.29	279.45 279.40	173	22	4	4.5	17	7	21 300	208	3.65	77 745	0.40	
M11190	271	175	34.943 34.887	38.943 38.887	301.44 301.31	301.76 301.63	301.57 301.52	301.68 301.63	188	25	4	5	19.5	8	25 500	226	3.7	94 350	0.40	
M11207	295	191	38.113 38.057	42.115 42.044	323.64 323.50	323.99 323.85	323.79 323.73	323.91 323.85	206	27	4	5	21	8	30 400	246	3.7	112 480	0.40	
M11225	324	210	41.295 41.224	48.295 48.224	355.39 355.25	355.74 355.60	355.54 355.48	355.66 355.60	223	29	7	6	23.5	10	36 100	270	3.75	135 375	0.50	
M11246	352	227	44.465 44.394	51.465 51.394	383.97 383.83	384.32 384.18	384.12 384.06	384.24 384.18	245	32	7	7	24.5	10	43 000	292	3.8	163 400	0.50	
M11269	384	248	47.645 47.574	54.645 54.574	415.70 415.55	416.09 415.93	415.86 415.80	415.99 415.93	267	33	7	7	26.5	10	51 400	320	3.8	195 320	0.50	
M11293	419	270	50.815 50.744	57.815 57.744	453.80 453.65	454.19 454.03	453.96 453.90	454.09 454.03	291	35	7	7	28	13	60 900	349	3.85	231 420	0.50	
M11320	457	295	57.165 57.094	64.165 64.094	495.07 494.92	495.46 495.30	495.23 495.17	495.36 495.30	317	40	7	7	32.5	13	72 900	381	3.85	280 665	0.60	
M1 1348	498	321	60.345 60.274	67.350 67.259	539.49 539.32	539.93 539.75	539.67 539.60	539.82 539.75	347	41	7	8	32.5	16	86 500	415	3.9	337 350	0.60	
M11380	546	352	66.700 66.609	73.700 73.609	583.94 583.77	584.38 584.20	584.12 584.05	584.27 584.20	378	46	7	8	37	16	102 500	455	3.9	399 750	0.60	
M11415	594	383	73.050 72.959	80.050 79.959	641.06 640.86	641.55 641.35	641.27 641.19	641.43 641.35	411	51	7	9	40	16	122 000	494	3.9	475 800	0.60	
M11453	647	417	79.400 79.309	89.100 89.009	691.86 691.66	692.35 692.15	692.07 691.99	692.23 692.15	450	56	9.7	10	45.5	17	146 000	538	3.9	569 400	0.70	
M1 1494	706	455	85.750 85.659	95.450 95.359	755.36 755.16	755.85 755.65	755.57 755.49	755.73 755.65	490	59	9.7	10	46.5	17	172 900	587	3.9	674 300	0.70	
M11538	769	496	92.100 92.009	101.800 101.709	825.18 824.95	825.73 825.50	825.41 825.32	825.59 825.50	535	64	9.7	11	50	19	205 000	640	3.9	799 500	0.70	

All dimensions are in mm



# Series 11

Max Shaft 460mm Max Load 80 tonne

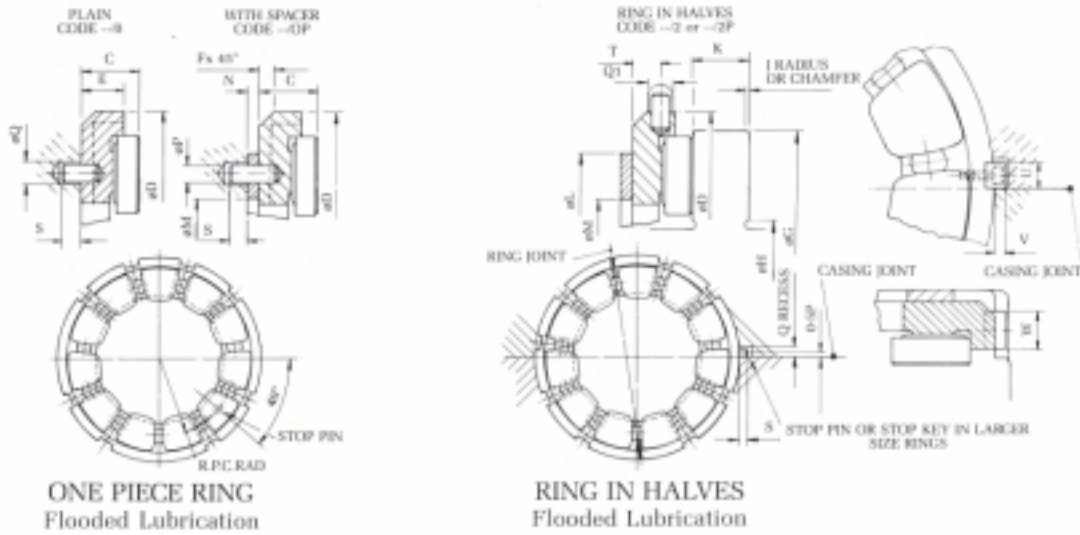

Collar Sizes				Spacer Dia.		Spacer Thickness (N)		Stop pin or key									Approx weight without spacer kg	Size
O. Dia G	I. Dia H	Rad J	Thick. K	O. Dia L	I. Dia M	Min N1	With M/c allow. N2	P	Q	Q1	R	S	T	U	V	W		
70	41	0.4	7	67	48	3.2	4.8	3.2	4.0	7	28.6	3.5	6	-	-	-	0.22	M1147
83	48	0.4	9	78	56	3.2	4.8	4.0	5.0	7	33.3	4	7	-	-	-	0.35	M1156
97	57	0.4	10	90	68	3.2	4.8	4.8	6.0	8	39.7	5	8	-	-	-	0.57	M1167
117	70	0.8	13	108	83	3.2	4.8	4.8	6.0	8	47.6	5	9	-	-	-	0.79	M1179
138	84	0.8	16	129	97	4.8	6.4	5.6	6.5	9	56.4	6	11	-	-	-	1.27	M1194
151	92	0.8	17	138	106	4.8	6.4	6.4	7.5	10	61.0	7	11	-	-	-	1.75	M11103
165	102	0.8	19	154	116	4.8	6.4	6.4	7.5	10	67.0	7	13	-	-	-	2.18	M11112
178	110	0.8	21	164	125	4.8	6.4	7.9	9.0	11	72.0	8	13	-	-	-	2.73	M11123
194	119	0.8	22	178	140	4.8	6.4	7.9	9.0	11	79.0	8	13	-	-	-	3.34	M11134
213	132	0.8	25	197	152	6.4	8.7	9.5	11.0	14	87.0	8	13	-	-	-	4.34	M11146
232	144	0.8	27	216	165	6.4	8.7	9.5	11.0	14	95.0	8	14	-	-	-	5.38	M11159
252	157	0.8	30	235	184	6.4	8.7	9.5	11.0	14	105.0	8	14	-	-	-	6.73	M11174
275	171	0.8	32	254	197	6.4	8.7	11.1	13.0	16	113.0	8	17	-	-	-	8.98	M11190
298	187	0.8	35	276	213	6.4	8.7	12.7	14.0	17	122.0	10	-	15.9	5.6	22.2	11.11	M11267
327	206	0.8	38	308	232	9.5	12.7	15.9	18.0	22	135.0	13	-	15.9	5.6	22.2	14.62	M11225
356	224	0.8	43	330	254	9.5	12.7	15.9	18.0	22	146.0	13	-	15.9	5.6	25.4	19.45	M11246
391	241	1.5	48	359	283	9.5	12.7	15.9	18.0	22	160.0	13	-	19.1	6.4	28.6	22.59	M11269
425	264	1.5	51	394	305	9.5	12.7	19.1	21.0	26	175.0	13	-	19.1	6.4	28.6	28.90	M11293
464	289	1.5	56	425	337	9.5	12.7	19.1	21.0	26	191.0	13	-	19.1	6.4	31.8	39.56	M11320
505	314	1.5	60	467	365	9.5	12.7	22.2	24.0	29	208.0	16	-	22.2	8	31.8	49.34	M11348
552	346	1.5	67	505	403	9.5	12.7	22.2	24.0	29	227.0	16	-	22.2	8	38.1	64.12	M11380
600	376	1.5	73	552	438	9.5	12.7	25.4	27.0	32	248.0	16	-	25.4	10	44.5	85.85	M11415
653	410	1.5	79	600	476	12.7	15.9	28.6	31.0	35	269.9	19	-	38.1	12.7	44.5	103.68	M11453
714	447	1.5	86	651	524	12.7	15.9	31.8	33.0	38	293.7	19	-	38.1	12.7	44.5	132.54	M11494
779	487	1.5	95	711	568	12.7	15.9	34.9	37.0	41	319.1	26	-	44.5	15.9	50.8	171.23	M11538

All dimensions are in mm

# Series 14

Max Shaft 400mm Max Load 43 tonne

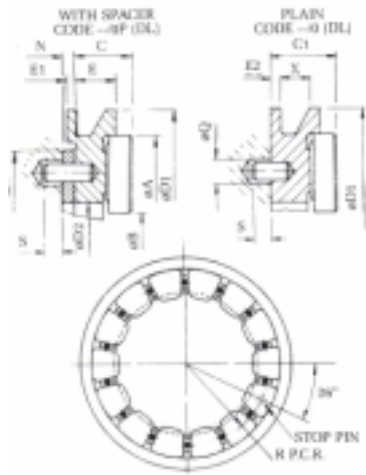

**ONE PIECE RING**  
Directed Lubrication

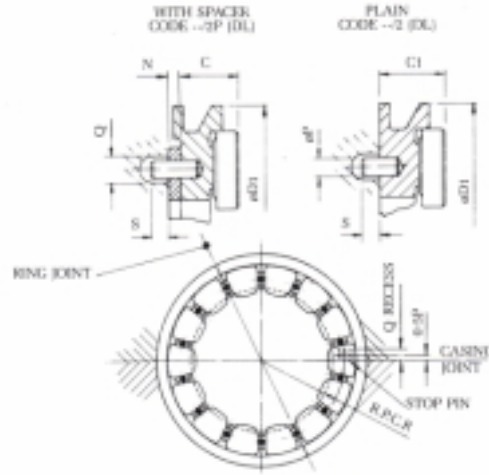

**RING IN HALVES**  
Directed Lubrication

Size	Thrust pad		Carrier Ring Dimensions													Thrust surface mm <sup>2</sup>	Mean dia. d	Allow. spec load MPa	Max load (see page 17) Newton	Total Axial Clearance mm
	O. Dia A	I. Dia B	Thickness		Ring O. Dia D	Housing bore		Ring O. Dia D1	I. Dia D2	E	E1	E2	X	F						
			C	C1		Housing bore	Housing bore													
M1447	82.5	58.5	12.710 12.670	-	95.13 95.04	95.34 95.25	-	-	61	10	-	-	-	3	2 010	71.3	2.1	4 221	0.20	
M1456	98.5	70	14.300 14.260	16.500 16.460	111.01 110.92	111.22 111.13	111.09 111.06	111.17 111.13	74	12	2.2	2.5	8.5	3	2 840	85	2.4	6 816	0.20	
M1467	117	82.5	15.890 15.850	18.090 18.050	130.04 129.94	130.28 130.18	130.14 130.10	130.22 130.18	88	13	2.2	2.5	10	4	4 020	101	2.65	10 653	0.20	
M1479	138	98.5	19.060 19.020	22.360 22.320	152.26 152.16	152.50 152.40	152.36 152.32	152.44 152.40	104	15	3.3	3	12.5	5	5 700	119	2.9	16 530	0.25	
M1494	165	117	20.650 20.610	23.953 23.897	183.98 183.87	184.27 184.15	184.10 184.05	184.20 184.15	124	16	3.3	3.5	12	5	8 050	143	3.2	25 760	0.25	
M14103	181	129	22.243 22.187	25.543 25.487	199.96 199.75	200.15 200.03	199.98 199.93	200.08 200.03	135	17	3.3	4	13	5	9 550	156	3.3	31 515	0.30	
M14112	197	140	23.823 23.707	27.123 27.067	218.91 218.80	219.20 219.08	219.03 218.98	219.13 219.08	148	19	3.3	4	14.5	6	11 400	170	3.4	38 760	0.30	
M14123	214	152	25.413 25.357	28.713 28.657	237.96 237.85	238.25 238.13	238.08 238.03	238.18 238.13	161	19	3.3	4	14.5	6	13 500	185	3.45	46 575	0.30	
M14134	235	165	27.003 26.947	31.003 30.947	260.16 260.03	260.48 260.35	260.29 260.24	260.40 260.35	176	21	4	4.5	15.5	6	16 100	203	3.5	56 350	0.35	
M14146	257	181	28.593 28.537	32.593 32.537	282.39 282.26	282.71 282.58	282.52 282.47	282.63 282.58	192	22	4	4.5	17	6	19 200	222	3.6	69 120	0.35	
M14159	279	197	31.763 31.707	35.763 35.707	307.79 307.66	308.11 307.98	307.92 307.87	308.03 307.98	209	24	4	5	17.5	6	22 900	241	3.6	82 440	0.35	
M14174	305	216	34.943 34.887	38.943 38.887	333.17 333.03	333.52 333.38	333.32 333.26	333.44 333.38	229	25	4	5	19.5	8	27 300	263	3.65	99 645	0.40	
M14190	332	235	38.113 38.057	42.115 42.044	361.74 361.60	362.09 361.95	361.89 361.83	362.01 361.95	249	29	4	5.5	21.5	10	32 500	286	3.7	120 250	0.40	
M14207	362	257	41.295 41.224	48.295 48.224	393.49 393.35	393.84 393.70	393.64 393.58	393.76 393.70	272	30	7	7	23	11	38 700	313	3.7	143 190	0.40	
M14225	394	279	44.465 44.394	51.465 51.394	425.22 425.07	425.61 425.45	425.38 425.32	425.51 425.45	297	33	7	7	26.5	11	46 000	340	3.75	172 550	0.50	
M14246	432	305	47.645 47.574	54.645 54.574	463.32 463.17	463.71 463.55	463.48 463.42	463.61 463.55	324	35	7	7	28	13	54 800	373	3.8	208 240	0.50	
M14269	470	333	50.815 50.744	57.815 57.744	501.39 501.22	501.83 501.65	501.57 501.50	501.72 501.65	353	37	7	8	27.5	13	65 000	406	3.8	247 000	0.50	
M14293	514	365	53.995 53.924	60.995 60.924	545.84 545.66	546.28 546.10	546.02 545.95	546.17 546.10	385	40	7	8	30.5	13	77 400	445	3.85	297 990	0.50	
M14320	558	396	60.345 60.274	67.350 67.259	596.62 596.47	597.08 596.90	596.82 596.75	596.97 596.90	420	43	7	8	34	14	92 300	483	3.85	355 355	0.60	
M14348	610	432	66.700 66.609	73.700 73.609	647.41 647.21	647.90 647.70	647.62 647.52	647.78 647.70	457	48	7	8	38.5	16	109 500	526	3.9	427 050	0.60	

All dimensions are in mm

# Series 14

Max Shaft 400mm Max Load 43 tonne

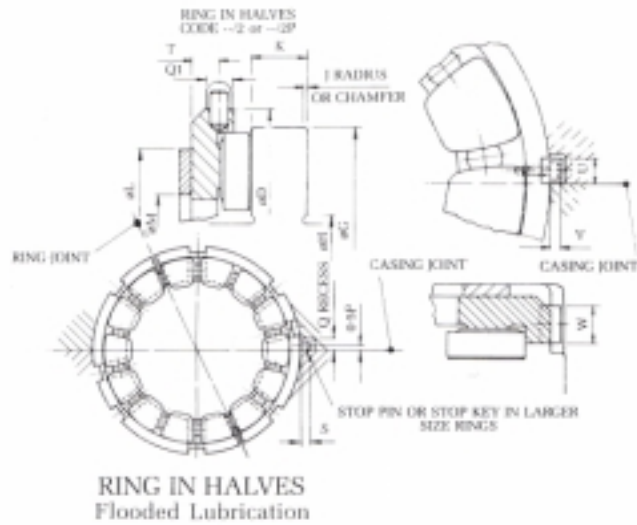
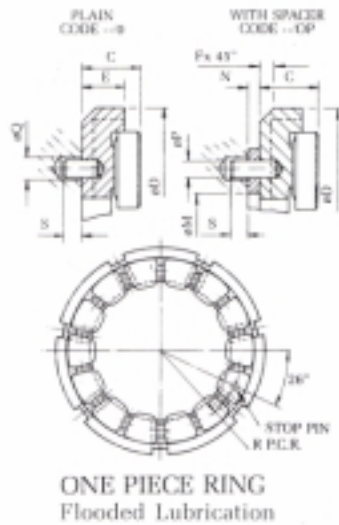

Collar Sizes				Spacer Dia.		Spacer Thickness (N)		Stop pin or key									Approx weight without spacer kg	Size
O. Dia G	I. Dia H	Rad J	Thick. K	O. Dia L	I. Dia M	Min N1	With M/c allow. N2	P	Q	Q1	R	S	T	U	V	W		
84	57	0.4	7	81	62	3.2	4.8	3.2	4.0	7	35.7	3.5	6	-	-	-	0.29	M1447
100	68	0.4	9	97	75	3.2	4.8	4.0	5.0	7	42.9	4	7	-	-	-	0.44	M1456
121	81	0.8	10	114	89	3.2	4.8	4.8	6.0	8	50.8	5	8	-	-	-	0.65	M1467
141	95	0.8	13	137	105	4.8	6.4	5.6	6.5	9	60.3	6	10	-	-	-	1.07	M1479
168	114	0.8	16	159	127	4.8	6.4	6.4	7.5	10	71.4	7	10	-	-	-	1.71	M1494
184	125	0.8	17	175	137	4.8	6.4	7.9	9.0	11	77.8	8	10	-	-	-	2.21	M14103
200	137	0.8	19	191	152	4.8	6.4	7.9	9.0	11	85.7	8	12	-	-	-	2.90	M14112
217	149	0.8	21	210	165	4.8	6.4	9.5	11.0	13	93.7	8	13	-	-	-	3.59	M14123
238	164	0.8	22	225	181	6.4	8.7	9.5	11.0	14	101.6	8	13	-	-	-	4.55	M14134
260	179	0.8	24	248	197	6.4	8.7	11.1	13.0	16	111.1	8	13	-	-	-	5.76	M14146
283	195	0.8	27	267	216	6.4	8.7	11.1	13.0	16	120.7	8	15	-	-	-	7.61	M14159
308	213	0.8	30	292	235	6.4	8.7	12.7	14.0	17	131.8	10	-	15.9	5.6	22.2	9.31	M14174
335	232	0.8	32	318	254	6.4	8.7	12.7	14.0	17	142.9	10	-	15.9	5.6	22.2	12.11	M14190
365	254	0.8	35	352	276	9.5	12.7	15.9	18.0	22	157.2	13	-	15.9	5.6	22.2	15.71	M14207
400	273	1.5	38	378	302	9.5	12.7	15.9	18.0	22	169.9	13	-	19.1	6.4	25.4	19.87	M14225
438	302	1.5	43	416	327	9.5	12.7	19.1	21.0	26	185.7	13	-	19.1	6.4	25.4	25.04	M14246
476	327	1.5	48	451	362	9.5	12.7	19.1	21.0	26	203.2	13	-	19.1	6.4	28.6	30.49	M14269
521	359	1.5	51	495	394	9.5	12.7	22.2	24.0	29	222.3	16	-	22.2	8	31.8	38.76	M14293
565	391	1.5	54	533	432	9.5	12.7	22.2	24.0	29	241.3	16	-	22.2	8	34.9	52.93	M14320
616	425	1.5	60	584	470	9.5	12.7	25.4	27.0	32	263.5	16	-	22.2	8	38.1	68.80	M14348

All dimensions are in mm

# Series 18

Max Shaft 420mm Max Load 32 tonne

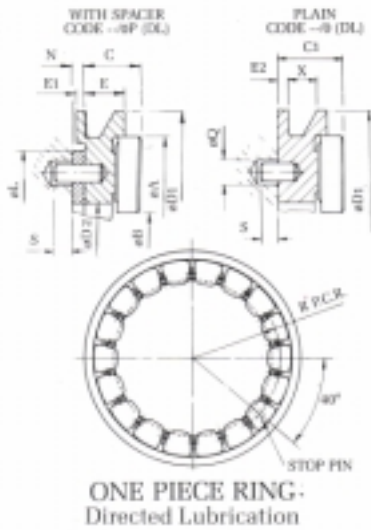

**ONE PIECE RING**  
Directed Lubrication

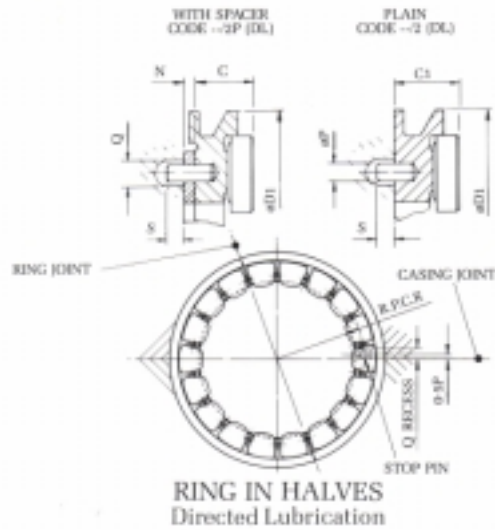

**RING IN HALVES**  
Directed Lubrication

Size	Thrust pad		Carrier Ring Dimensions													Thrust surface mm <sup>2</sup>	Mean dia. d	Allow. spec load MPa	Max load (see page 17) Newton	Total Axial Clearance mm	
	O. Dia	I. Dia	Thickness		Ring O. Dia	Housing bore	Ring O. Dia	Housing bore	I. Dia												
	A	B	C	C1	D		D1		D2	E	E1	E2	X	F							
M1847	103	78.5	14.300 13.260	16.500 16.460	114.18 114.09	114.39 114.30	114.26 114.23	114.34 114.30	80	12	2.2	3	8	4	2 580	91.7	2.1	5 418	0.20		
M1856	122	93.5	15.890 15.850	18.090 18.050	133.21 133.11	133.45 133.35	133.30 133.27	133.39 133.35	96	13	2.2	3	9	4	3 650	109	2.4	8 760	0.20		
M1867	146	111	17.470 17.430	19.670 19.630	161.79 161.69	162.03 161.93	161.88 161.85	161.97 161.93	116	14	2.2	3	10.5	5	5 150	130	2.65	13 647	0.20		
M1879	173	132	19.060 19.020	22.360 22.320	190.33 190.22	190.62 190.50	190.45 190.40	190.55 190.50	16	3.3	4	11	5	7	300	154	2.9	21 170	0.25		
M1894	206	159	22.243 22.187	25.543 25.487	225.26 225.15	225.55 225.43	225.38 225.33	225.48 225.43	164	17	3.3	4	12.5	6	10 300	184	3.2	32 960	0.25		
M18103	224	171	23.823 23.767	27.123 27.067	244.31 244.20	244.60 244.48	244.43 244.38	244.53 244.48	178	19	3.3	4	14.5	6	12 300	200	3.3	40 590	0.30		
M18112	244	187	26.413 25.357	29.413 29.357	266.51 266.39	266.83 266.70	266.64 266.59	266.75 266.70	195	21	4	4.5	15.5	6	14 700	217	3.4	49 980	0.30		
M18123	267	205	28.593 28.537	32.593 32.537	288.74 288.61	289.06 288.93	288.87 288.82	288.98 288.93	213	22	4	5	16	7	17 400	237	3.45	60 030	0.30		
M18134	292	224	30.173 30.117	34.173 34.117	317.29 317.15	317.64 317.50	317.44 317.38	317.56 317.50	232	24	4	5	17.5	7	20 800	260	3.5	72 800	0.35		
M18146	318	244	31.763 31.707	35.763 35.707	345.87 345.73	346.22 346.08	346.02 345.96	346.14 346.08	254	25	4	5	19.5	8	24 800	282	3.6	89 280	0.35		
M18159	346	265	34.943 34.887	38.943 38.887	374.44 374.30	374.79 374.65	374.59 374.53	374.71 374.65	277	27	4	5.5	20	10	29 400	307	3.6	105 840	0.35		
M18174	378	289	38.113 38.057	42.115 42.044	406.17 406.02	406.56 406.40	406.33 406.27	406.46 406.40	302	30	4	5.5	22.5	10	35 000	337	3.65	127 750	0.40		
M18190	413	316	41.295 41.224	48.295 48.224	444.27 444.12	444.66 444.50	444.43 444.37	444.56 444.50	330	32	7	7	24.5	11	41 700	367	3.7	154 290	0.40		
M18207	451	346	44.465 44.394	51.465 51.394	482.37 482.22	482.76 482.60	482.53 482.47	482.66 482.60	359	33	7	7	26.5	11	49 700	401	3.7	183 890	0.40		
M18225	492	378	47.645 47.574	54.645 54.574	526.79 526.62	527.23 527.05	526.97 526.90	527.12 527.05	392	35	7	7	28	13	59 000	438	3.75	221 250	0.50		
M18246	536	413	50.815 50.744	57.815 57.744	571.24 571.07	571.68 571.50	571.42 571.35	571.57 571.50	429	38	7	7	31	13	70 300	478	3.8	267 140	0.50		
M18269	584	448	53.995 53.924	60.995 60.924	622.04 621.87	622.48 622.30	622.22 622.15	622.37 622.30	467	40	7	8	30.5	14	83 900	519	3.8	318 820	0.50		

All dimensions are in mm

# Series 18

Max Shaft 420mm Max Load 32 tonne

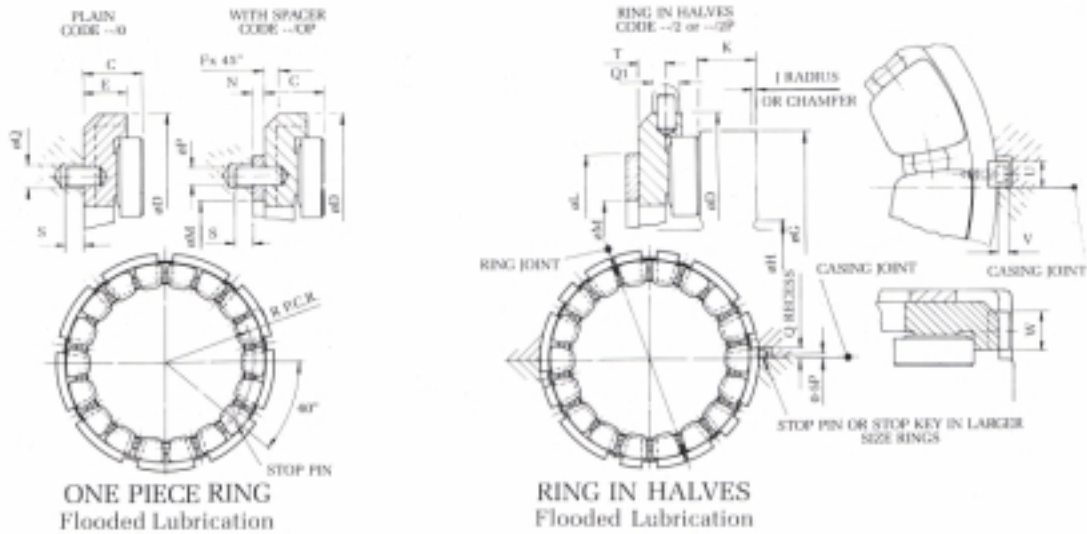

Collar Sizes				Spacer Dia.		Spacer Thickness (N)		Stop pin or key									Approx weight without spacer kg	Size
O. Dia G	I. Dia H	Rad J	Thick. K	O. Dia L	I. Dia M	Min N1	With M/c allow. N2	P	Q	Q1	R	S	T	U	V	W		
105	76	0.4	7	102	83	3.2	4.8	4.0	5.0	7	46.0	4	7	-	-	-	0.41	M1847
124	90	0.4	9	121	98	3.2	4.8	4.8	6.0	8	54.8	5	8	-	-	-	0.57	M1856
149	110	0.8	10	143	117	3.2	4.8	5.6	6.5	9	65.1	6	9	-	-	-	0.99	M1867
176	130	0.8	13	171	140	4.8	6.4	6.4	7.5	10	77.8	7	10	-	-	-	1.46	M1879
210	156	0.8	16	203	165	4.8	6.4	7.9	9.0	11	92.1	8	11	-	-	-	2.32	M1894
227	168	0.8	17	219	181	4.8	6.4	7.9	9.0	11	100.1	8	13	-	-	-	2.99	M18103
248	184	0.8	19	241	197	6.4	8.7	9.5	11.0	14	109.5	8	13	-	-	-	3.85	M18112
270	202	0.8	21	260	216	6.4	8.7	9.5	11.0	14	119.1	8	15	-	-	-	4.97	M18123
295	221	0.8	22	286	235	6.4	8.7	11.1	13.0	16	130.2	8	15	-	-	-	6.46	M18134
321	240	0.8	24	308	257	6.4	8.7	11.1	13.0	16	141.3	8	16	-	-	-	8.21	M18146
349	262	0.8	27	337	279	6.4	8.7	12.7	14.0	17	154.0	10	-	15.9	5.6	22.2	10.36	M18159
381	286	0.8	30	365	308	6.4	8.7	12.7	14.0	17	168.3	10	-	15.9	5.6	25.4	13.13	M18174
419	311	0.8	32	406	330	9.5	12.7	15.9	18.0	22	184.2	13	-	15.9	5.6	25.4	16.93	M18190
457	340	0.8	35	441	365	9.5	12.7	15.9	18.0	22	201.6	13	-	19.1	6.4	28.6	21.86	M18207
498	371	0.8	38	483	394	9.5	12.7	19.1	21.0	26	219.1	13	-	19.1	6.4	28.6	27.56	M18225
543	406	1.5	43	521	432	9.5	12.7	19.1	21.0	26	238.1	13	-	22.2	8	31.8	34.50	M18246
591	441	1.5	48	565	476	9.5	12.7	22.2	24.0	29	260.4	16	-	22.2	8	31.8	42.71	M18269

All dimensions are in mm



# Series 7 Large

Max Shaft 440mm Max Load 305 tonne

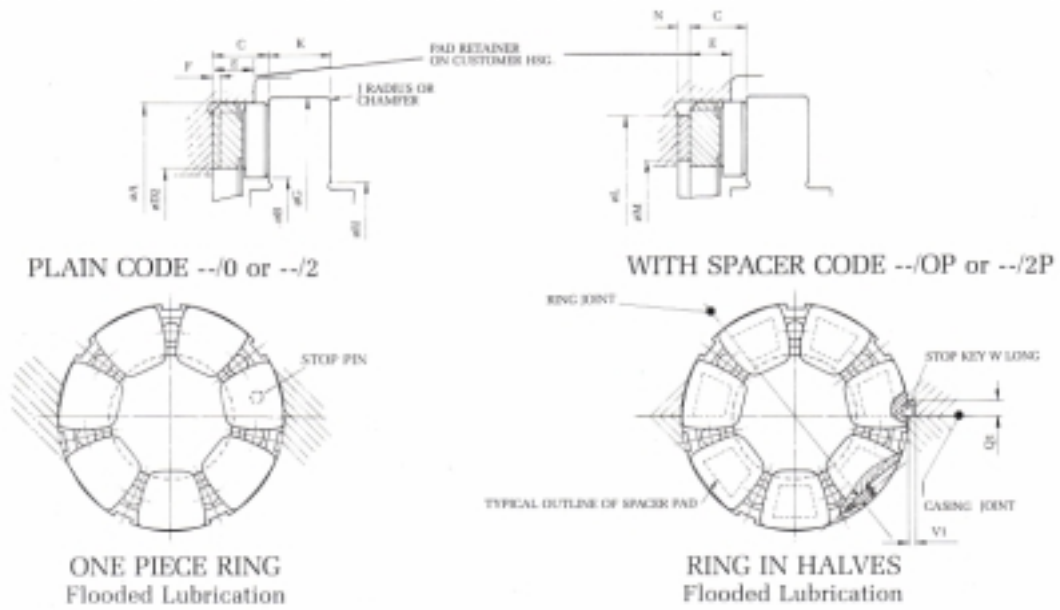

Size	Thrust ring dimensions						Thrust Surf. cm <sup>2</sup>	Mean Dia d	Max Spec load MPa	Max load See p 17 tonne	Total axial clearance	Collar sizes				Spacer seat		Spacer thick (N)		Stop key			Approx. wt without spacer kg	
	Pad O. Dia	Hsg. bore	Pad I. Dia	Ring thick	Ring I. Dia							O. Dia	I. Dia	Rad.	Thick	O. Dia	I. Dia	Min.	With M/c allow.	K'way Width	K'way Depth	Length		
	A	B	C	D2	E	F						G	H	J	K	L	M	N1	N2	Q1	V1	W		
M7538	538	538.18 538.00	260	92.00 91.91	298	64	12	1 301	404	3.9	53.08	0.7	544	254	1.5	95	473	335	12.7	15.9	23	8	38	94
M7588	583	583.18 583.00	278	98.00 97.91	320	72	12	1 561	436	4.0	63.69	0.7	589	272	1.5	108	508	362	15.9	19	23	8	38	120
M7642	630	630.18 630.00	297	108.00 107.91	343	79	14	1 858	469	4.0	75.81	0.7	636	291	1.5	117	549	389	19	22	23	8	43	157
M7700	681	681.20 681.00	318	117.00 116.91	368	86	15	2 213	506	4.0	90.29	0.7	687	312	1.5	130	594	419	19	22	26	8	46	202
M7764	737	737.20 737.00	341	127.00 126.90	395	93	17	2 632	546	4.0	107.39	0.7	747	331	3	152	641	451	19	22	29	9	49	261
M7833	797	797.20 797.00	365	140.00 139.90	424	103	18	3 135	589	4.0	127.91	0.7	807	355	3	159	692	486	19	22	33	10	55	341
M7909	864	864.23 864.00	392	152.00 151.90	457	12	20	3 729	636	4.0	152.14	0.7	874	382	3	178	749	521	19	22	33	10	60	440
M7992	936	936.23 936.00	421	165.00 164.90	492	121	21	4 439	688	4.0	181.11	0.7	946	411	3	194	813	562	19	22	37	11	65	567
M71082	1 016	1 016.26 1 016.00	453	181.00 180.88	530	133	24	5 284	744	4.0	215.59	0.7	1 026	443	3	216	879	606	19	22	41	12	71	740
M71181	1 102	1 102.26 1 102.00	488	194.00 193.88	572	142	25	6 290	805	4.0	256.63	0.7	1 112	478	3	238	952	657	19	22	46	13.5	75	940
M71288	1 196	1 196.26 1 196.00	526	210.00 209.88	618	153	26	7 490	872	4.0	305.59	0.7	1 206	516	3	264	1 035	708	19	22	51	15	82	1 248

All dimensions are in mm

# Series 8 Large

Max Shaft 570mm Max Load 350 tonne

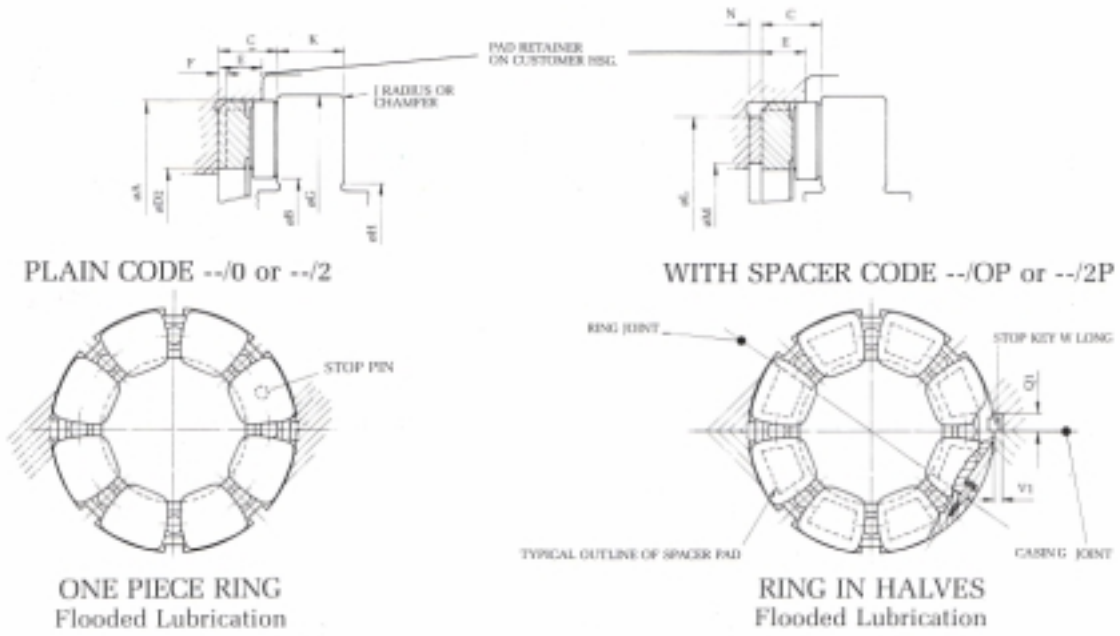

Size	Thrust ring dimensions							Thrust Surf. cm <sup>2</sup>	Mean Dia d	Max Spec load MPa	Max load See p 17 tonne	Total axial clearance	Collar sizes				Spacer seat		Spacer thick (N)			Stop key			Approx. wt without spacer kg
	Pad O. Dia	Hsg. bore	Pad I. Dia	Ring thick	Ring I. Dia								O. Dia	I. Dia	Rad.	Thick	O. Dia	I. Dia	Min.	With M/c allow.	K'way Width	K'way Depth	Length		
	A		B	C	D2	E	F						G	H	J	K	L	M	N1	N2	Q1	V1	W		
M8588	645	645.20 645.00	343	98.00 97.91	385	72	13	1 781	501	4.0	72.66	0.7	651	337	1.5	108	575	429	15.9	19	26	8	38	137	
M8642	697	697.20 697.00	367	108.00 107.91	413	79	14	2 123	539	4.0	86.62	0.7	703	361	1.5	117	619	460	19	22	26	8	43	178	
M8700	753	753.20 753.00	393	117.00 116.91	443	86	15	2 529	581	4.0	103.18	0.7	763	383	3	130	667	492	19	22	29	9	46	229	
M8764	814	814.23 814.00	421	127.00 126.90	475	93	17	3 006	626	4.0	122.64	0.7	824	411	3	143	721	527	19	22	33	10	49	295	
M8833	881	881.23 881.00	452	140.00 139.90	511	103	18	3 581	676	4.0	146.10	0.7	891	442	3	159	781	572	19	22	33	10	55	386	
M8909	954	954.23 954.00	486	152.00 151.90	551	112	20	4 265	730	4.0	174.01	0.7	964	476	3	175	845	616	19	22	37	11	60	499	
M8992	1 034	1 034.26 1 034.00	523	165.00 164.90	594	121	21	5 077	789	4.0	207.14	0.7	1 044	513	3	194	914	664	19	22	41	12	65	643	
M81082	1 121	1 121.26 1 121.00	563	181.00 180.88	640	133	24	6 045	853	4.0	246.64	0.7	1 131	553	3	216	991	718	19	22	46	13.5	71	837	
M81181	1 216	1 216.26 1 216.00	607	194.00 193.88	691	142	25	7 194	923	4.0	293.52	0.7	1 226	597	3	238	1 073	775	19	22	51	15	75	1 064	
M81288	1 319	1 319.26 1 319.00	655	210.00 209.88	746	153	26	8 561	1000	4.0	349.29	0.7	1 329	645	3	264	1 164	835	19	22	5	17	82	1 415	

All dimensions are in mm

# Series 9 Large

Max Shaft 710mm Max Load 393 tonne

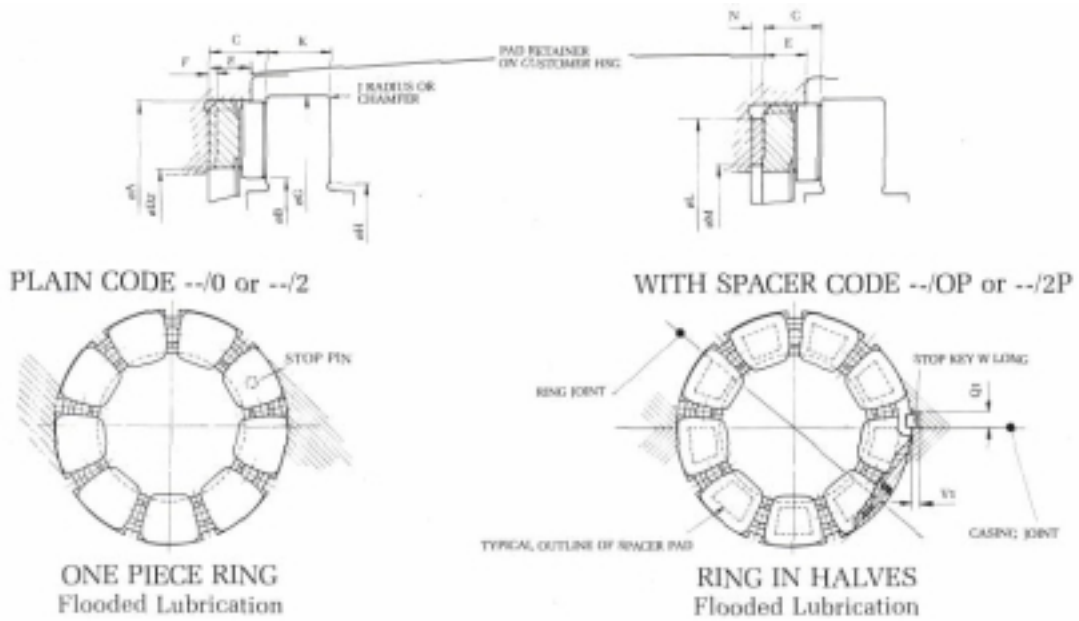

Size	Thrust ring dimensions							Thrust Surf. cm <sup>2</sup>	Mean Dia d	Max Spec load MPa	Max load See p 17 tonne	Total axial clearance	Collar sizes				Spacer seat		Stop key				Approx. wt without spacer kg	
	Pad O. Dia	Hsg. bore	Pad I. Dia	Ring thick	Ring I. Dia								O. Dia	I. Dia	Rad.	Thick	O. Dia	I. Dia	Min.	With M/c allow.	K'way Width	K'way Depth		Length
	A	B	C	D2	E	F	G						H	J	K	L	M	N1	N2	Q1	V1	W		
M9588	708	708.20 708.00	407	98.00 97.91	449	72	13	2 006	565	4.0	81.84	0.7	714	401	1.5	105	638	492	15.9	19	29	9	38	153
M9642	764	764.20 764.00	436	108.00 107.91	482	79	14	2 387	608	4.0	97.39	0.7	774	426	3	114	689	527	19	22	29	9	43	198
M9700	825	825.23 825.00	467	117.00 116.91	517	86	15	2 845	655	4.0	116.08	0.7	835	457	3	127	743	568	19	22	33	10	46	255
M9764	892	892.23 892.00	501	127.00 126.90	555	93	17	3 387	706	4.0	138.19	0.7	902	491	3	140	800	610	19	22	37	11	49	323
M9833	965	965.23 965.00	538	140.00 139.90	597	103	18	4 032	762	4.0	164.51	0.7	975	528	3	156	867	657	19	22	41	12	55	432
M9909	1 044	1 044.26 1 044.00	579	152.00 151.90	643	112	20	4 800	822	4.0	195.84	0.7	1 054	569	3	171	937	708	19	22	41	12	60	557
M9992	1 131	1 131.26 1 131.00	623	165.00 164.90	694	121	21	5 710	889	4.0	232.97	0.7	1 141	613	3	187	1 013	765	19	22	46	13.5	65	717
M91082	1 226	1 226.26 1 226.00	671	181.00 180.88	748	133	24	6 800	961	4.0	277.44	0.7	1 236	661	3	210	1 099	825	19	22	51	15	71	935
M91181	1 329	1 329.31 1 329.00	724	194.00 193.88	808	142	25	8 090	1040	4.0	330.07	0.7	1 339	714	3	232	1 187	892	19	22	57	17	75	1 188
M91288	1 442	1 442.31 1 442.00	781	210.00 209.88	873	153	26	9 632	1127	4.0	392.99	0.7	1 452	771	3	254	1 289	962	19	22	64	17	82	1 579

All dimensions are in mm

# Series 10 Large

Max Shaft 830mm Max Load 437 tonne

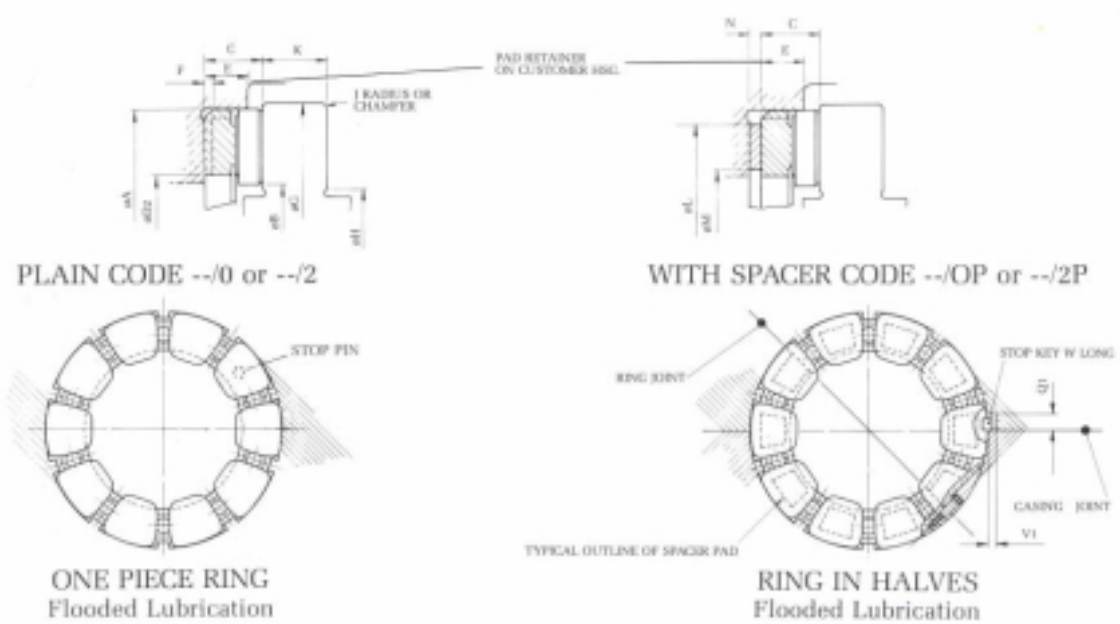

Size	Thrust ring dimensions							Thrust Surf. cm <sup>2</sup>	Mean Dia d	Max Spec load MPa	Max load See p 17 tonne	Total axial clearance	Collar sizes				Spacer seat		Stop key				Approx. wt without spacer kg	
	Pad O. Dia	Hsg. bore	Pad I. Dia	Ring thick	Ring I. Dia								O. Dia	I. Dia	Rad.	Thick	O. Dia	I. Dia	Min.	With M/c allow.	K'way Width	K'way Depth		Length
	A	B	C	D2	E	F	G						H	J	K	L	M	N1	N2	Q1	V1	W		
M10588	769	769.20 769.00	470	98.00 97.91	512	72	13	2 232	628	4.0	91.07	0.7	779	460	3	105	702	556	15.9	19	33	10	38	169
M10642	830	830.23 830.00	504	108.00 107.91	550	79	14	2 652	676	4.0	108.20	0.7	840	494	3	117	756	597	19	22	33	10	43	219
M10700	897	897.23 897.00	540	117.00 116.91	590	86	15	3 161	728	4.0	128.97	0.7	907	530	3	127	816	641	19	22	37	11	46	282
M10764	969	969.23 969.00	580	127.00 126.90	634	93	17	3 761	785	4.0	153.45	0.7	979	570	3	143	879	689	19	22	41	12	49	364
M10833	1 048	1 048.26 1 048.00	623	140.00 139.90	682	103	18	4 477	847	4.0	182.66	0.7	1 058	613	3	156	952	743	19	22	46	13.5	55	468
M10909	1 134	1 134.26 1 134.00	670	152.00 151.90	735	112	20	5 329	914	4.0	217.42	0.7	1 144	660	3	171	1 029	800	19	22	46	13.5	60	615
M10992	1 228	1 228.26 1 228.00	722	165.00 164.90	793	121	21	6 348	988	4.0	259.00	0.7	1 238	712	3	191	1 111	864	19	22	51	15	65	793
M101082	1 330	1 330.31 1 330.00	778	181.00 180.88	855	133	24	7 555	1068	4.0	308.24	0.7	1 340	768	3	210	1 203	933	19	22	57	17	71	1 032
M101181	1 442	1 442.31 1 442.00	839	194.00 193.88	923	142	25	8 994	1156	4.0	366.96	0.7	1 452	829	3	232	1 305	1 006	19	22	64	17	75	1 313
M101288	1 564	1 564.31 1 564.00	906	210.00 209.88	998	153	26	10 703	1252	4.0	436.68	0.7	1 574	896	3	257	1 416	1 086	19	22	71	19	82	1 743

All dimensions are in mm

# Series 11 Large

Max Shaft 950mm Max Load 480 tonne

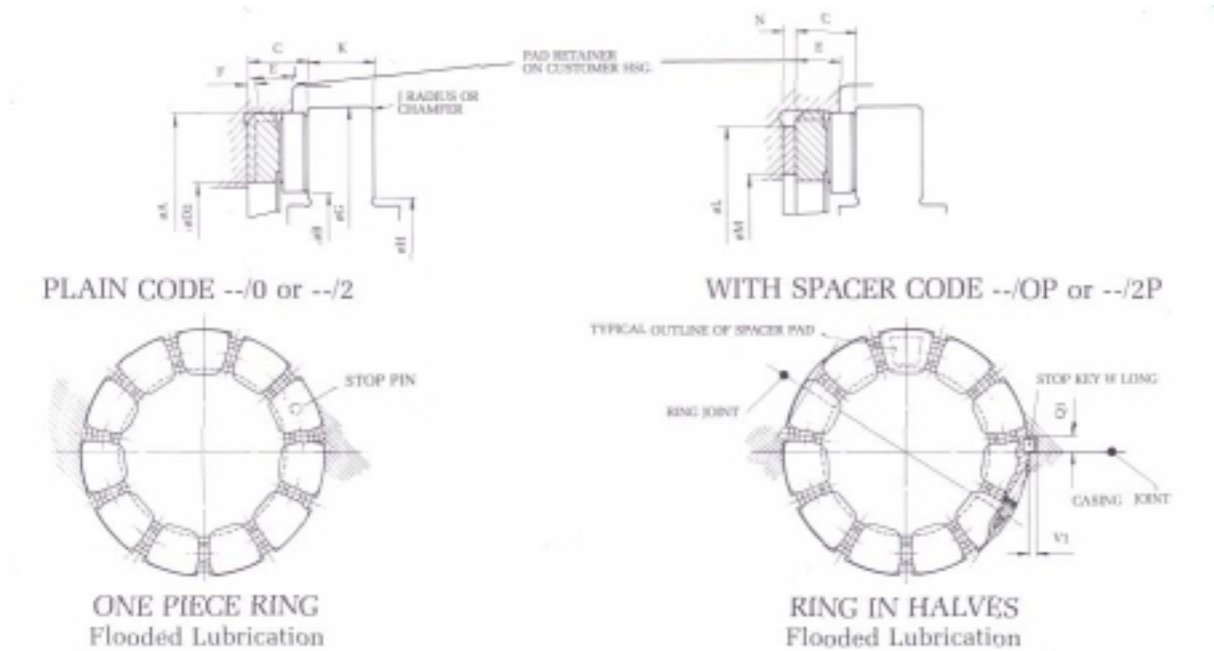

Size	Thrust ring dimensions							Thrust Surf. cm <sup>2</sup>	Mean Dia d	Max Spec load MPa	Max load See p 17 tonne	Total axial clearance	Collar sizes				Spacer seat		Stop key				Approx. wt without spacer kg	
	Pad O. Dia	Hsg. bore	Pad I. Dia	Ring thick	Ring I. Dia								O. Dia	I. Dia	Rad.	Thick	O. Dia	I. Dia	Min.	With M/c allow.	K'way Width	K'way Depth		Length
	A	B	C	D2	E	F	G						H	J	K	L	M	N1	N2	Q1	V1	W		
M11588	832	823.23 823.00	533	98.00 97.91	575	72	13	2 452	691	4.0	100.04	0.7	842	523	3	105	765	619	15.9	19	37	11	38	185
M11642	897	897.23 897.00	571	108.00 107.91	617	79	14	2 923	743	4.0	119.26	0.7	907	561	3	117	822	664	19	22	37	11	43	240
M11700	968	968.23 968.00	613	117.00 116.91	663	86	15	3 477	801	4.0	141.86	0.7	978	603	3	127	889	714	19	22	41	12	46	308
M11764	1 046	1 046.26 1 046.00	658	127.00 126.90	712	93	17	4 135	863	4.0	168.71	0.7	1 056	648	3	143	959	768	19	22	46	13.5	49	398
M11833	1 131	1 131.26 1 131.00	707	140.00 139.90	766	103	18	4 929	931	4.0	201.10	0.7	1 141	697	3	159	1 035	822	19	22	46	13.5	55	522
M11909	1 223	1 223.26 1 223.00	761	152.00 151.90	826	112	20	5 865	1005	4.0	239.29	0.7	1 233	751	3	171	1 121	892	19	22	51	15	60	673
M11992	1 324	1 324.31 1 324.00	820	165.00 164.90	891	121	21	6 981	1086	4.0	284.82	0.7	1 334	810	3	191	1 210	962	19	22	57	17	65	867
M111082	1 435	1 435.31 1 435.00	884	181.00 180.88	961	133	24	8 310	1175	4.0	339.05	0.7	1 445	874	3	213	1 311	1038	19	22	64	17	71	1 130
M111181	1 555	1 555.31 1 555.00	955	194.00 193.88	1 039	142	25	9 890	1271	4.0	403.51	0.7	1 565	945	3	235	1 419	1 124	19	22	71	19	75	1 436
M111288	1 686	1 686.37 1 686.00	1031	210.00 209.88	1 123	153	26	11 774	1376	4.0	480.38	0.7	1 696	1 021	3	257	1 540	1 216	19	22	81	21	82	1 907

All dimensions are in mm



# Series 12 Large

Max Shaft 1080mm Max Load 524 tonne

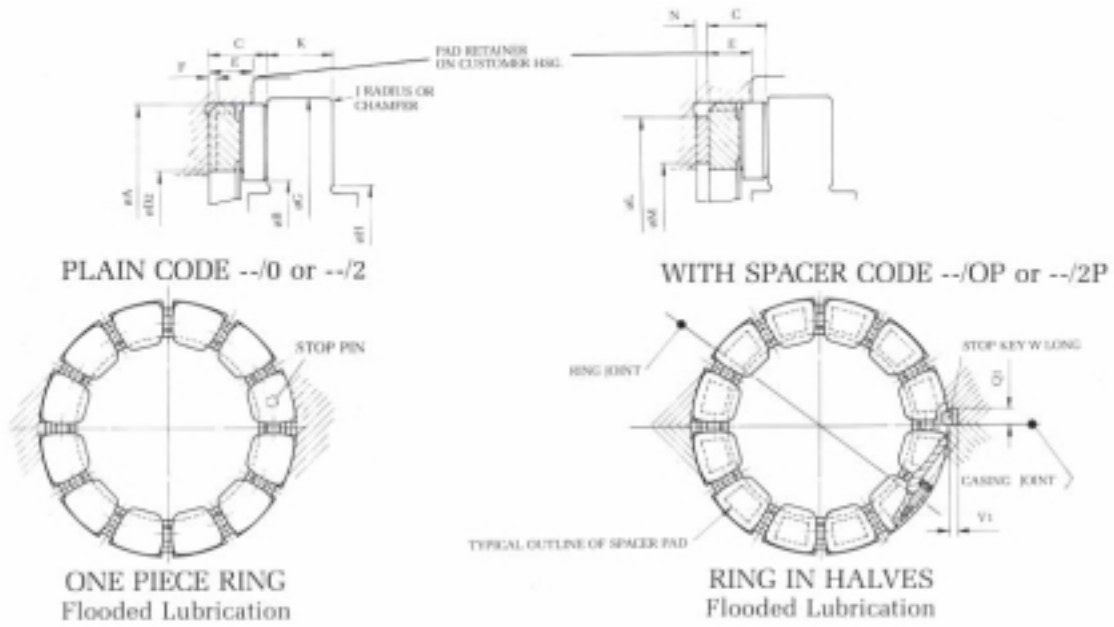

Size	Thrust ring dimensions							Thrust Surf. cm <sup>2</sup>	Mean Dia d	Max Spec load MPa	Max load See p 17 tonne	Total axial clearance	Collar sizes				Spacer seat		Stop key				Approx. wt without spacer kg	
	Pad O. Dia	Hsg. bore	Pad I. Dia	Ring thick	Ring I. Dia								O. Dia	I. Dia	Rad.	Thick	O. Dia	I. Dia	Min.	With M/c allow.	K'way Width	K'way Depth		Length
	A		B	C	D2	E	F						G	H	J	K	L	M	N1	N2	Q1	V1		W
M12588	894	894.23 894.00	596	98.00 97.91	638	72	13	2 677	753	4.0	109.22	0.7	904	586	3	108	825	679	15.9	19	37	11	38	201
M12642	964	964.23 964.00	638	108.00 107.91	684	79	14	3 187	811	4.0	130.03	0.7	974	628	3	117	889	730	19	22	41	12	43	261
M12700	1 041	1 041.26 1 041.00	685	117.00 116.91	735	86	15	3 794	873	4.0	154.80	0.7	1 051	675	3	130	959	784	19	22	46	13.5	46	336
M12764	1 124	1 124.26 1 124.00	736	127.00 126.90	790	93	17	4 516	941	4.0	184.25	0.7	1 134	726	3	143	1 035	845	19	22	51	15	49	433
M12833	1 215	1 215.26 1 215.00	792	140.00 139.90	851	103	18	5 374	1015	4.0	219.26	0.7	1 225	782	3	156	1 121	911	19	22	51	15	55	567
M12909	1 314	1 314.31 1 314.00	852	152.00 151.90	917	112	20	6 400	1096	4.0	261.12	0.7	1 324	842	3	175	1 210	981	19	22	57	17	60	732
M12992	1 422	1 422.31 1 422.00	918	165.00 164.90	989	121	21	7 613	1184	4.0	310.61	0.7	1 432	908	3	191	1 308	1060	19	22	64	17	65	944
M121082	1 540	1 540.31 1 540.00	990	181.00 180.88	1 067	133	24	9 064	1281	4.0	369.81	0.7	1 550	980	3	213	1 416	1146	19	22	71	19	71	1 229
M121181	1 669	1 669.37 1 669.00	1069	194.00 193.88	1 153	142	25	10 794	1386	4.0	440.40	0.7	1 679	1 059	3	235	1 534	1 238	19	22	81	21	75	1 563
M121288	1 809	1 809.37 1 809.00	1155	210.00 209.88	1 247	153	26	12 845	1500	4.0	524.08	0.7	1 822	1 142	3	260	1 664	1 340	19	22	91	23.5	82	2 074

All dimensions are in mm

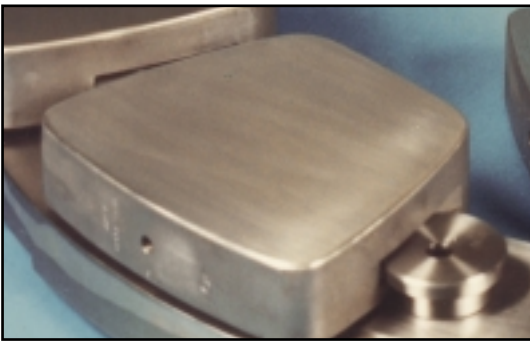

## Engineered Bearing Solutions

The type of bearing described in this brochure is one of a complete range of shaft support products which Waukesha Bearings (WBC) manufactures for rotating machinery (turbines, compressors, pumps, gearboxes, motors, generators, couplings, etc).

### **Some other products in the Waukesha Bearing range:**

Equalized and Non-equalized  
Tilting Pad Thrust Bearings.

Tilting Pad Journal Bearings.

Horizontal Bearing Assemblies,  
Self Contained and Force  
Lubricated.

Vertical Bearing Assemblies, Self  
Contained and Force Lubricated.

Medium and Heavywall Fixed  
Profile Journal Bearings.

Fixed Profile Thrust Washers.

Marine Thrust and Line Shaft  
Units.

Bearings for Water and Product  
Lubrication.

Active Magnetic Bearing Systems.

Spares, Repairs and Bearings to  
Customer Drawings.

**Note:** The information in this brochure is given in good faith but no guarantee is given or implied in respect of such information.

WBC products are subject to continued development and WBC reserves the right to make changes in the specification and design of their products without prior notice.

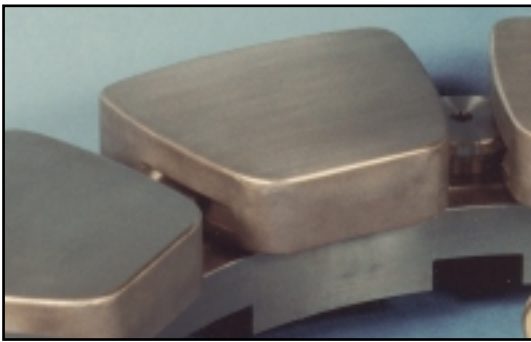

## Thrust Bearing Application Questionnaire

Fax to +44 (0) 1923 845160 (Europe) or (262) 506 3001 (USA)

E-mail to [eurosales@waukbearing.com](mailto:eurosales@waukbearing.com) (Europe) or [sales@waukbearing.com](mailto:sales@waukbearing.com) (USA)

Name:	
Company:	
Project Ref:	
Date:	
GENERAL INFORMATION	
Application:	
Bearing style/code/description:	
Shaft diameter:	(mm/in)
Quantity/Delivery	
THRUST LOAD	
Normal:	(N / lbf)
Max. continuous:	
Minimum load:	
At the instant of start-up (0 rev/min):	
Max. momentary:	
LUBRICANT	
Type:	
or ISO viscosity grade:	
Temperature at bearing inlet:	(°C / °F)
Pressure at bearing inlet:	(bar / psi)
SHAFT SPEED	
Normal:	(rev/min)
Max. continuous:	
Overspeed:	
Bi- or Uni-directional:	
SPECIAL NEEDS	
Instrumentation (Thermocouples, RTD's)	
API specification.	

P.O. Box 1616  
Waukesha  
WI 53186-1616  
USA  
Tel: (262) 5063000  
Fax: (262) 506 3001  
[sales@waukbearing.com](mailto:sales@waukbearing.com)

Argyle House  
Joel Street  
Northwood Hills  
Middlesex  
HA6 1LN  
UK  
Tel: +44(0) 1923 845100  
Fax: +44(0) 1923 845160  
[eurosales@waukbearing.com](mailto:eurosales@waukbearing.com)

[www.waukbearing.com](http://www.waukbearing.com)